



Disney · PIXAR  
**TOY**  
STORY



7591



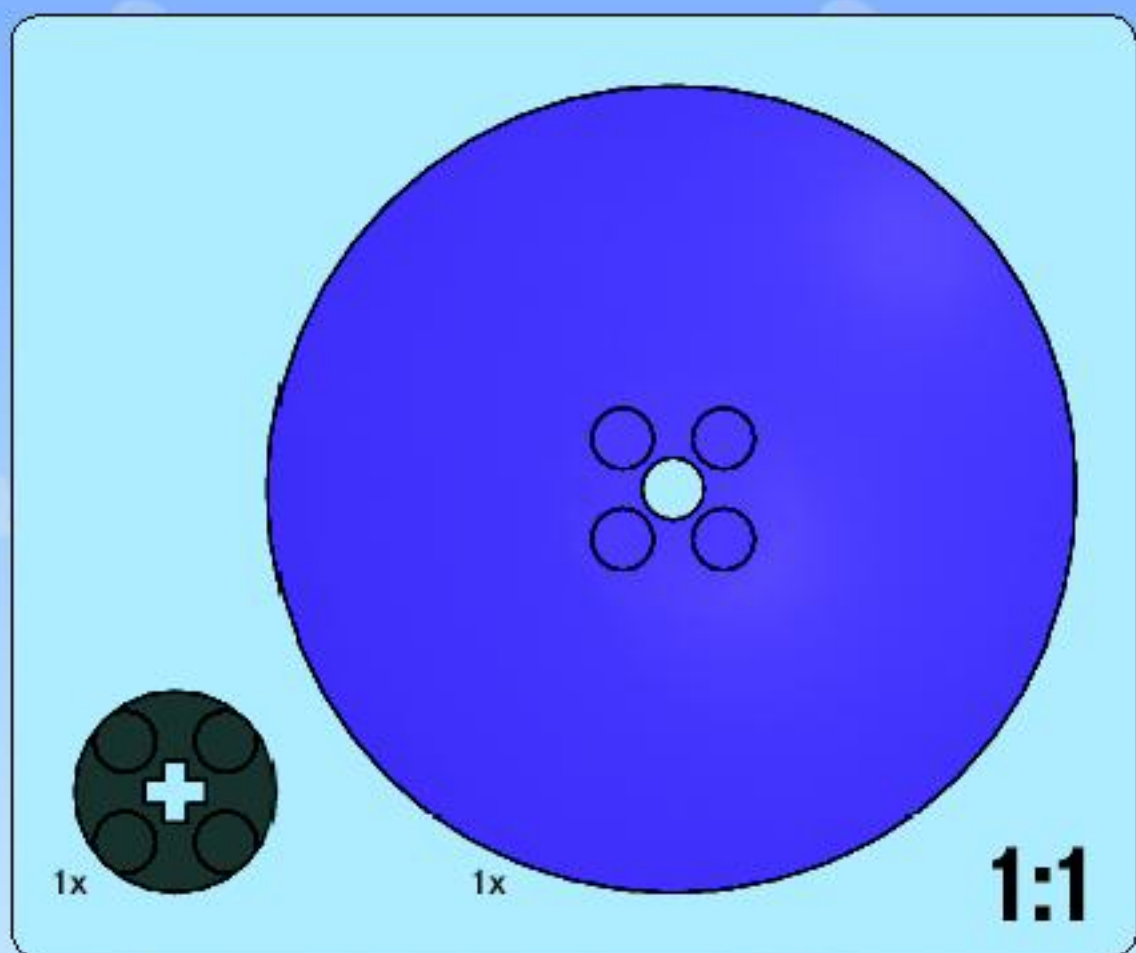

**1**

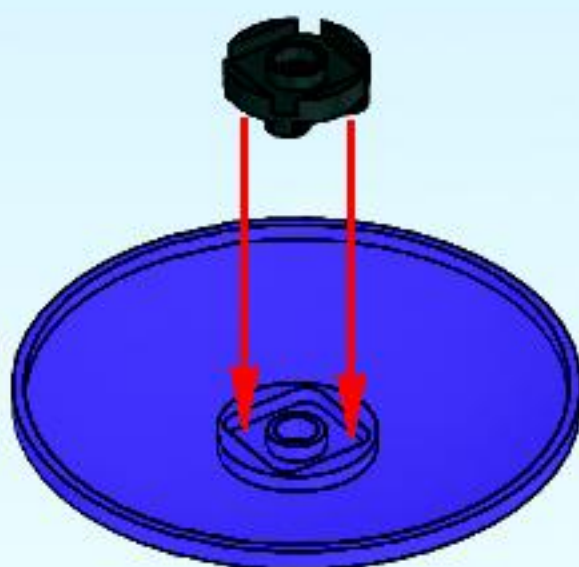

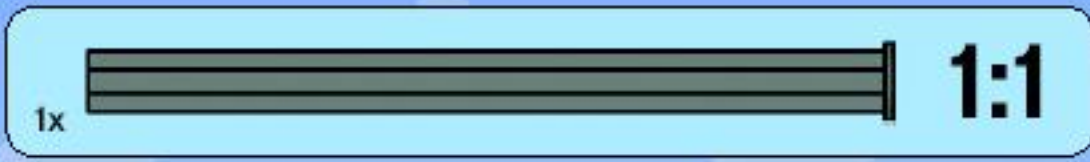

2

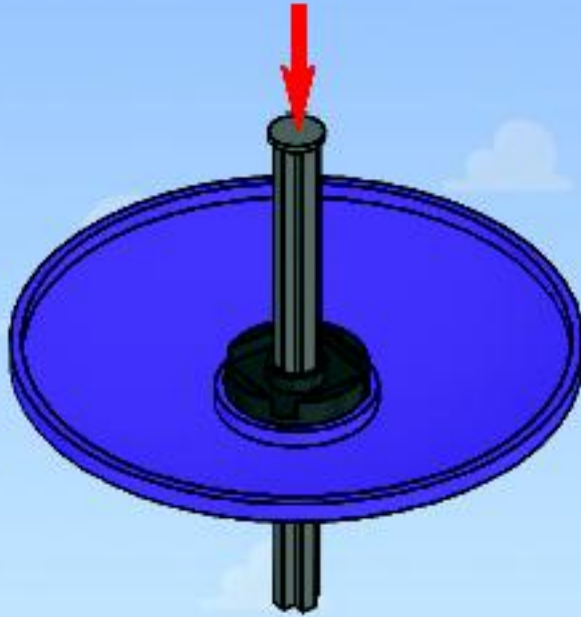

3

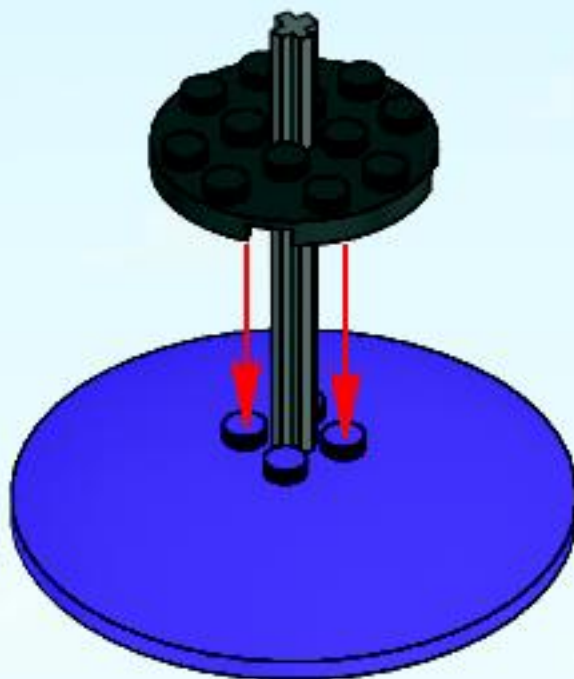

4



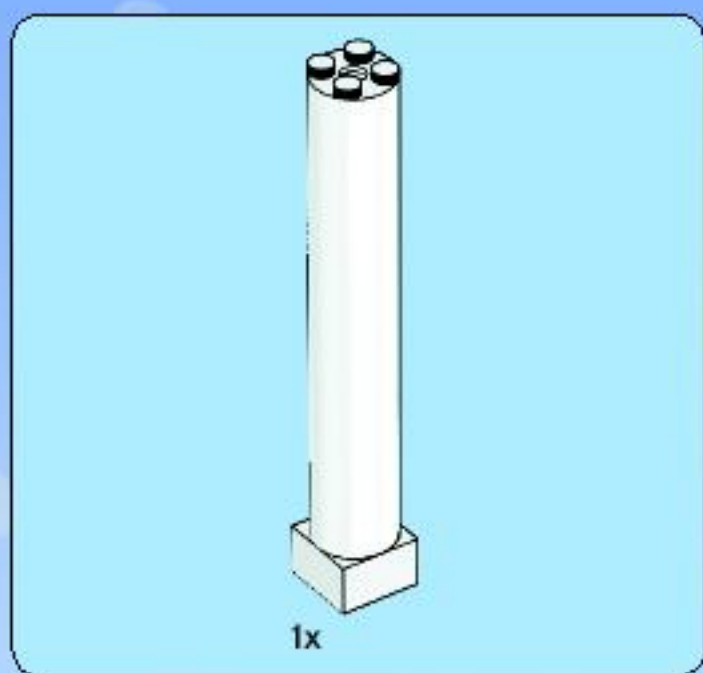

4

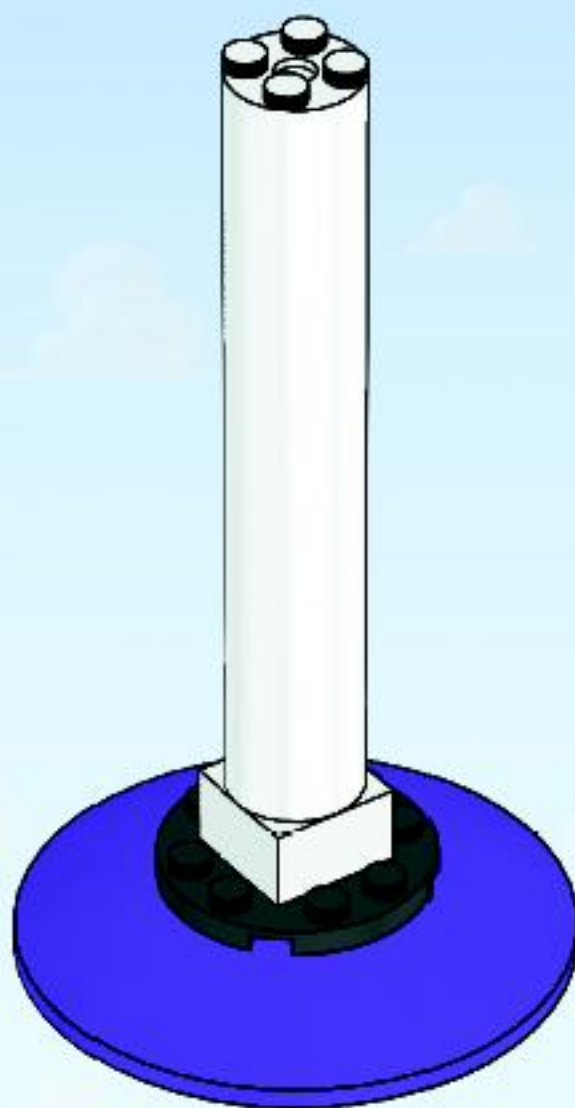



5

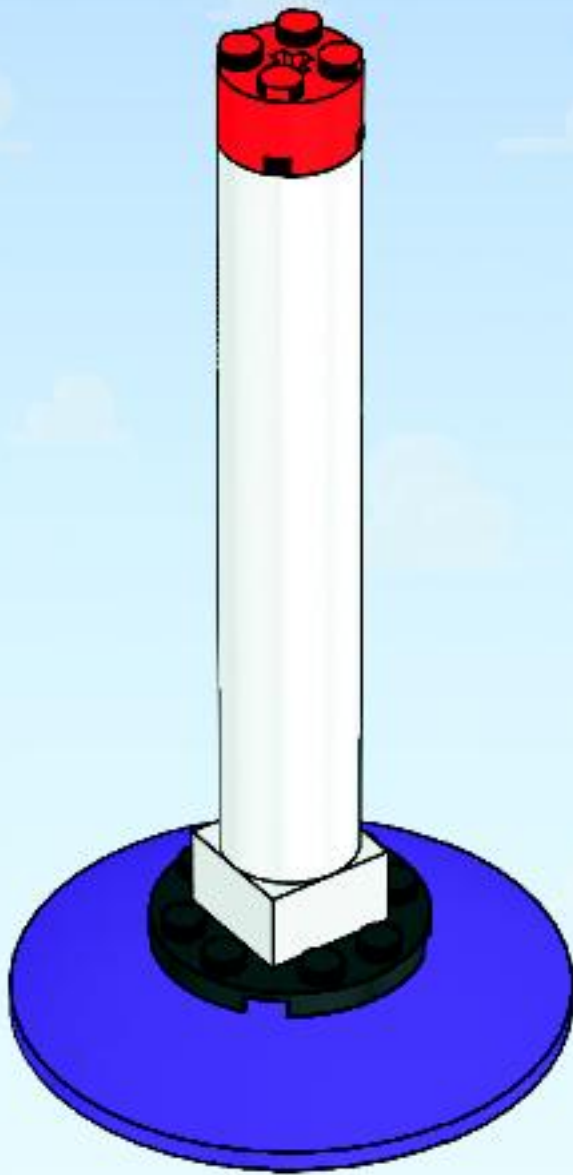

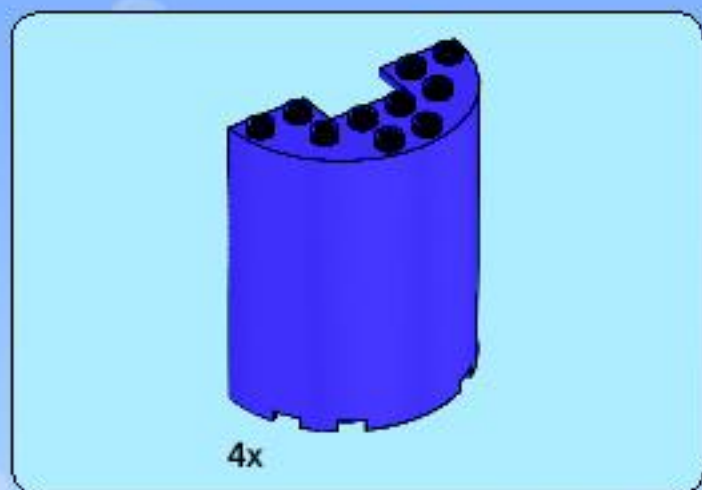

6

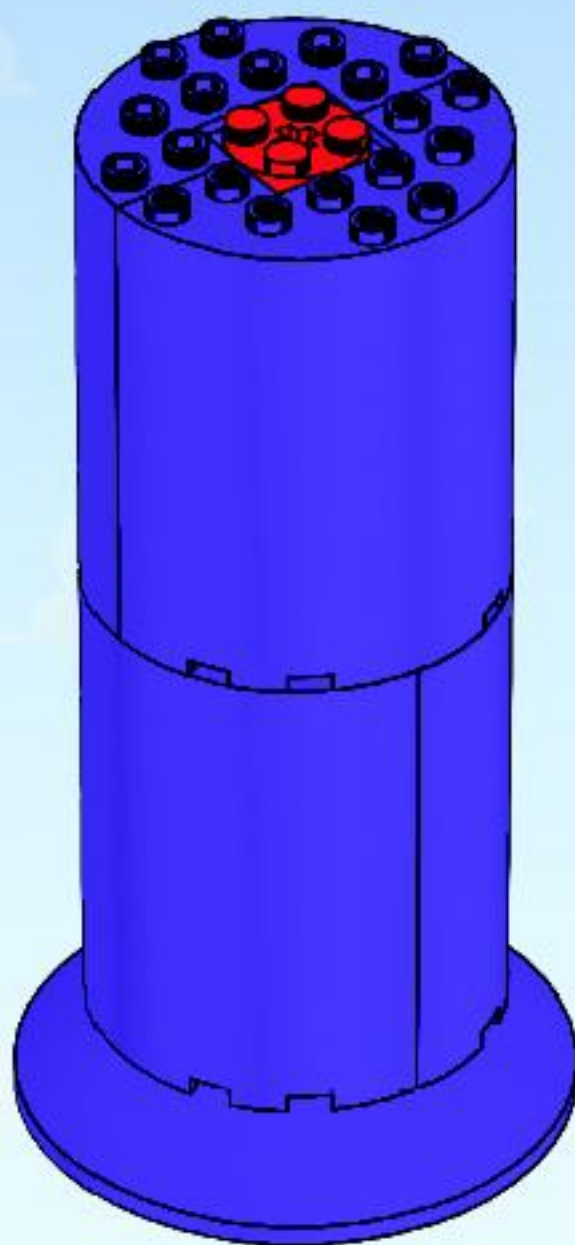



1x

7

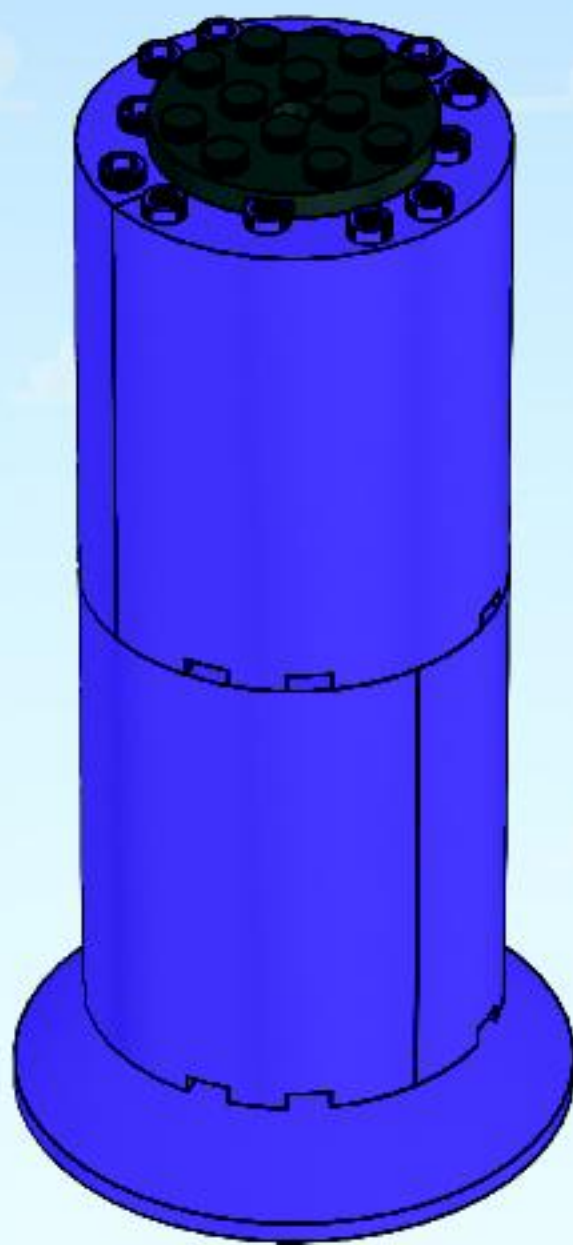

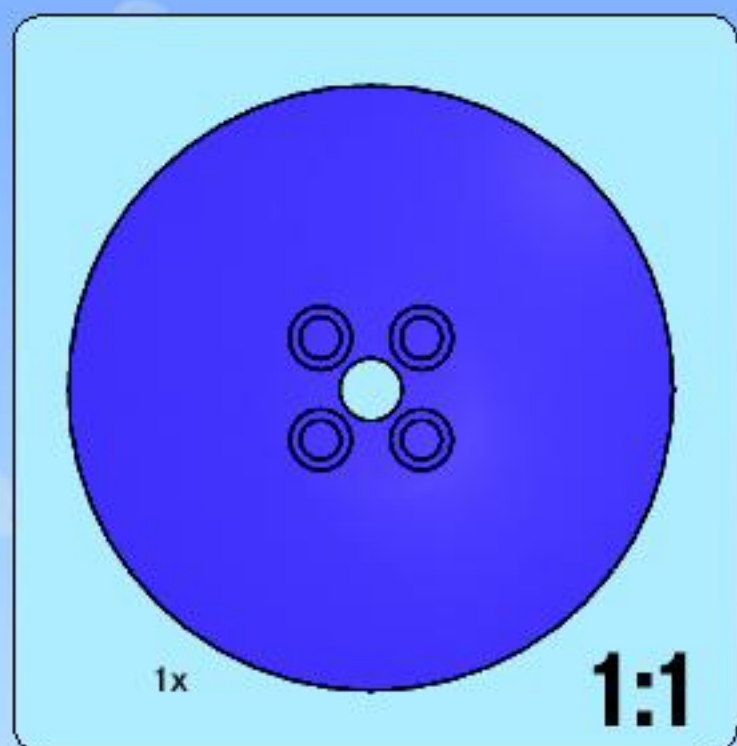

8

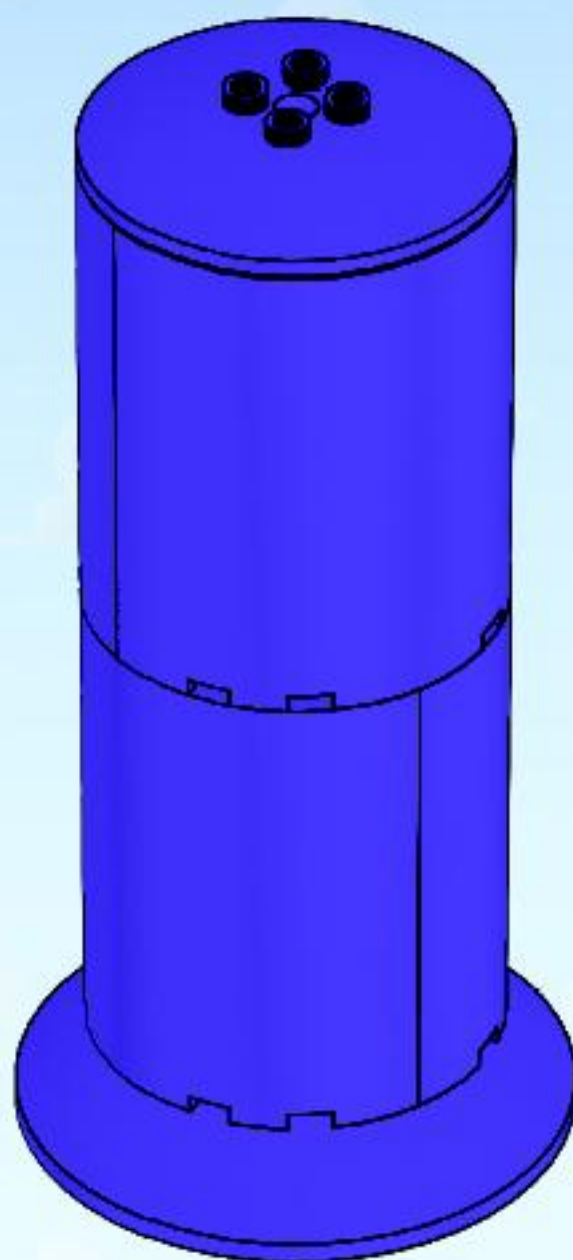



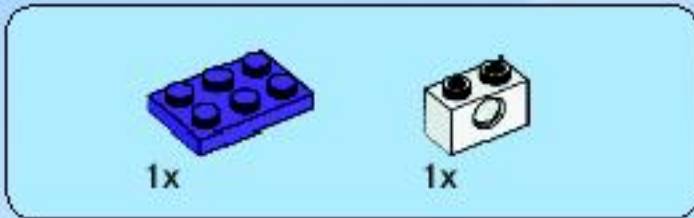
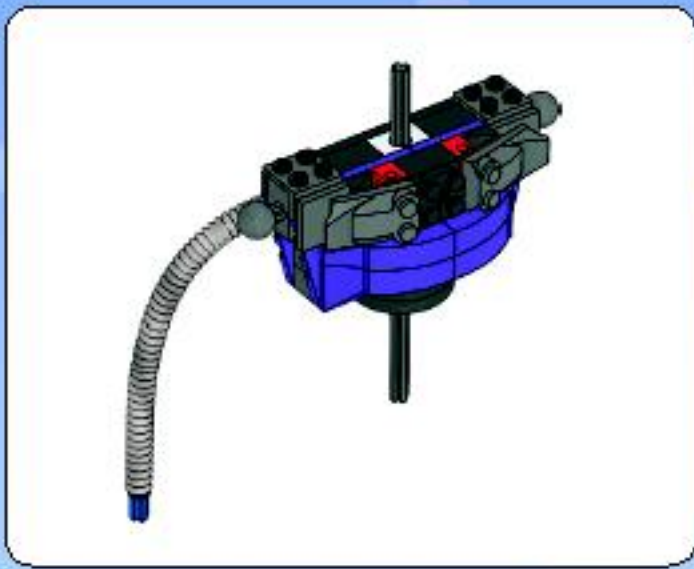

1

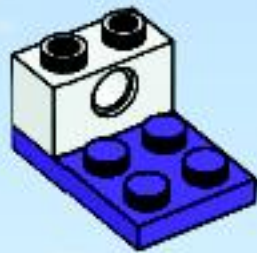

2

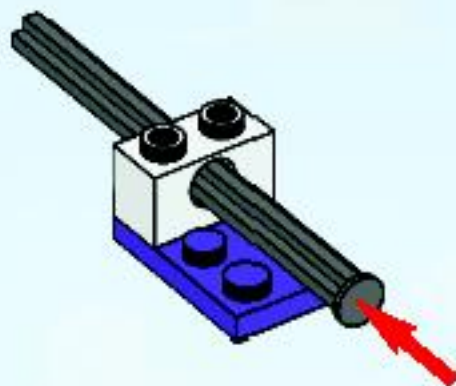

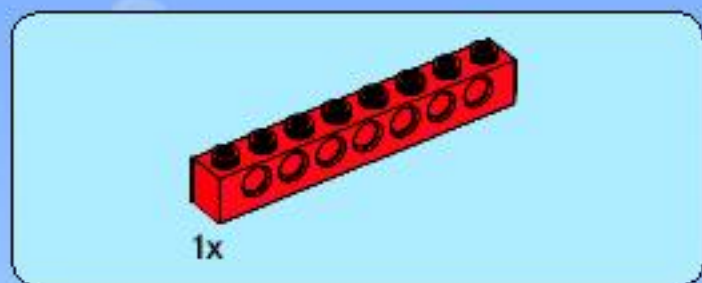

3

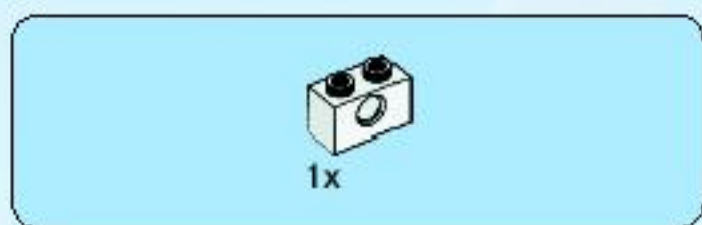
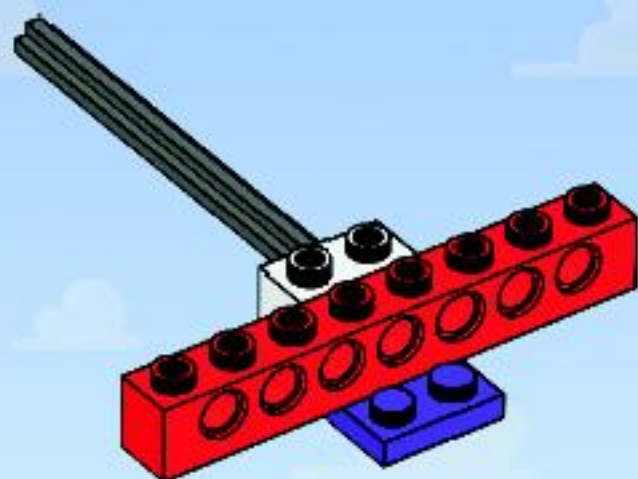

4

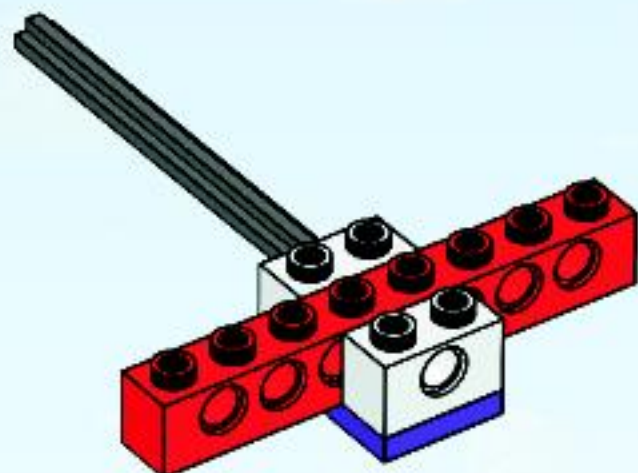



2x

# 5

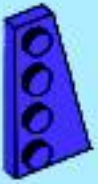
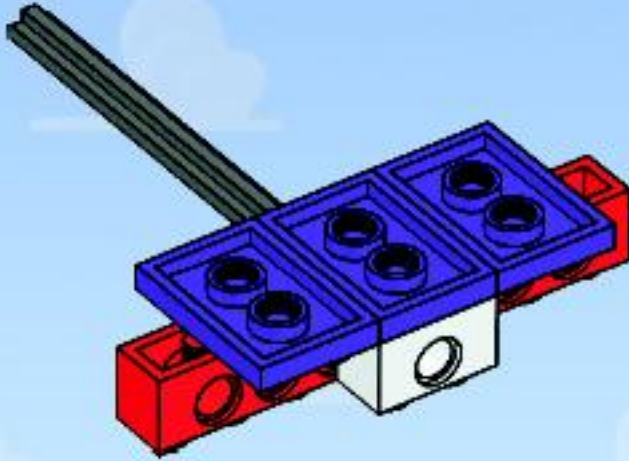

1x



1x

# 6

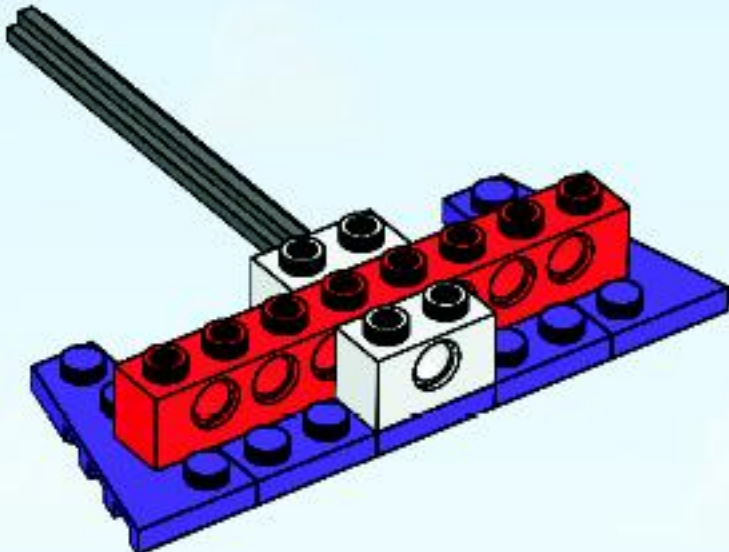

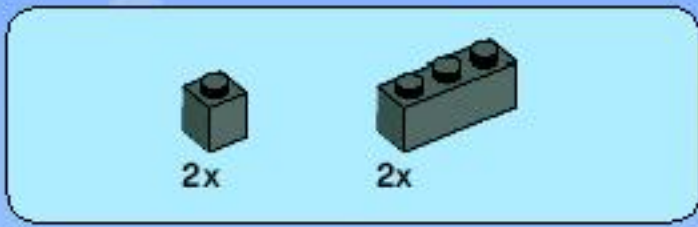

7

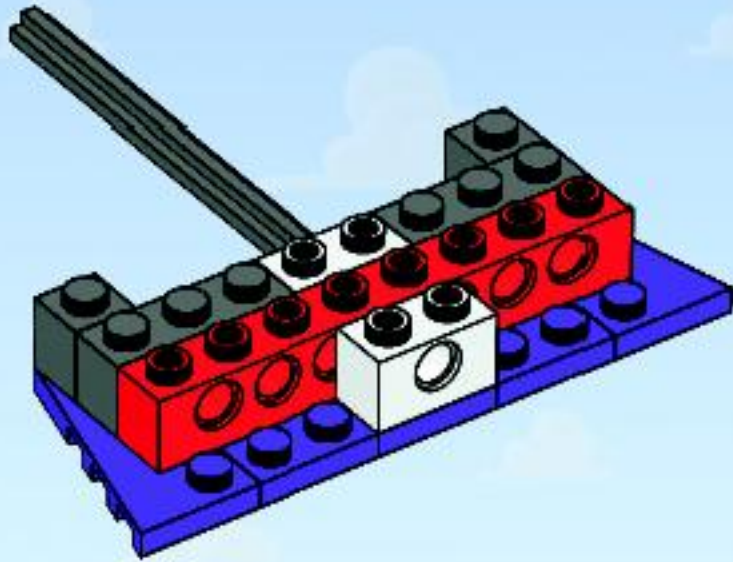



8

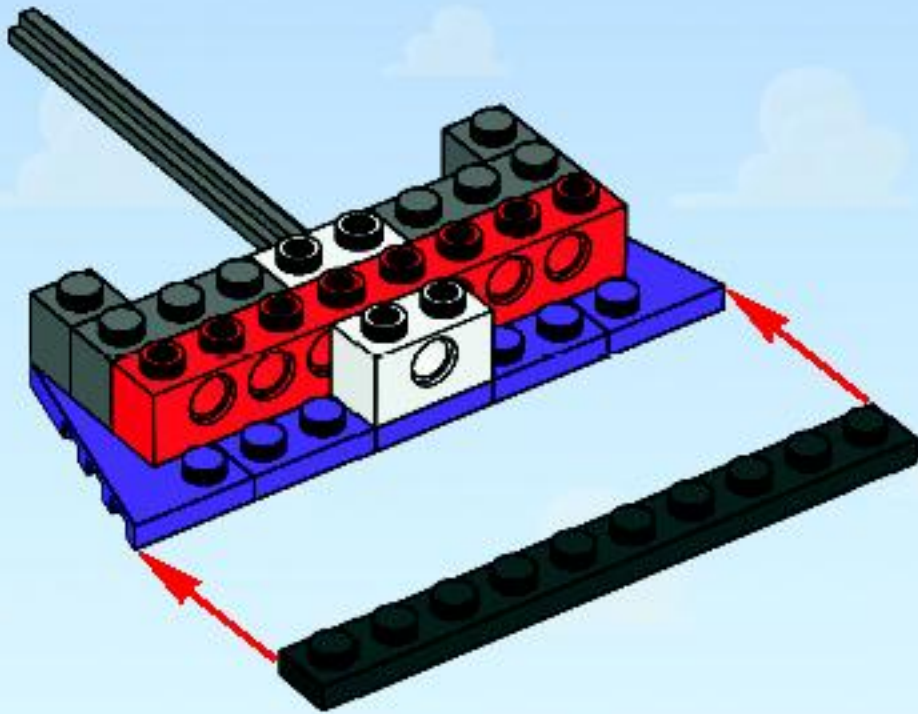





2x

9

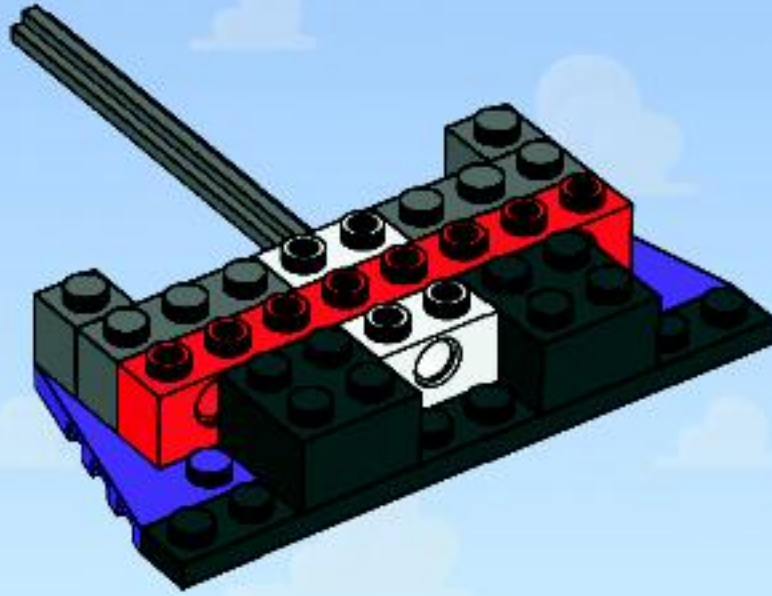

2x

10

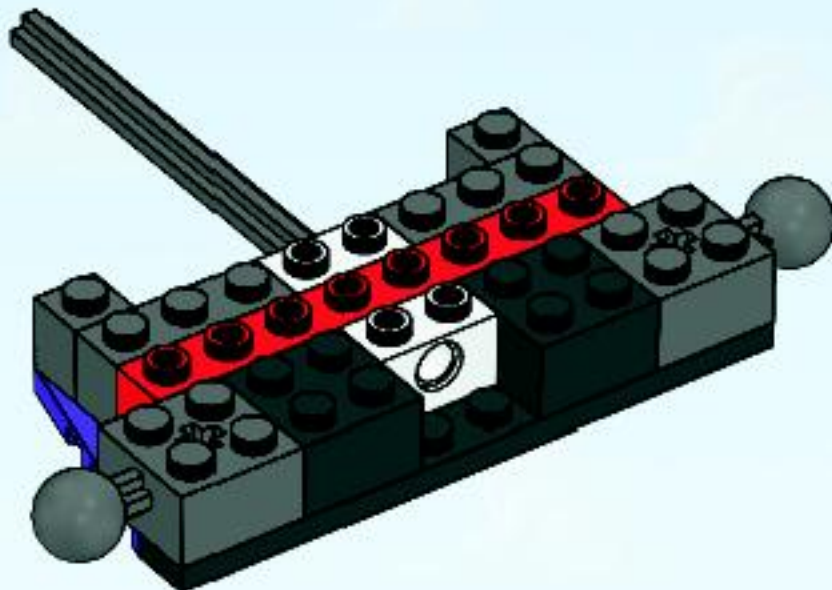

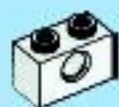

1x



1x



1:1

# 11

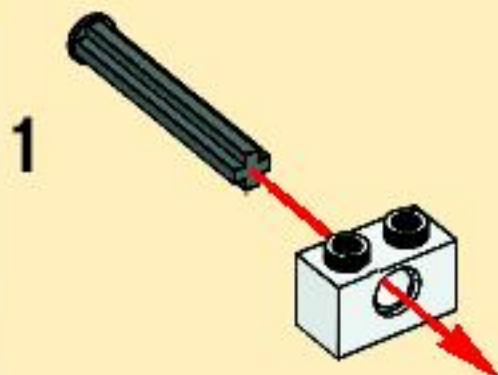

2

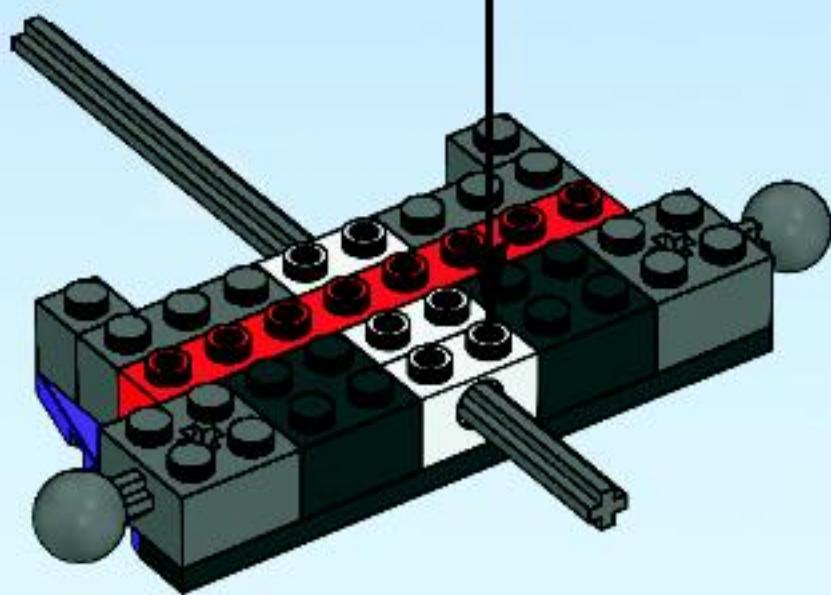

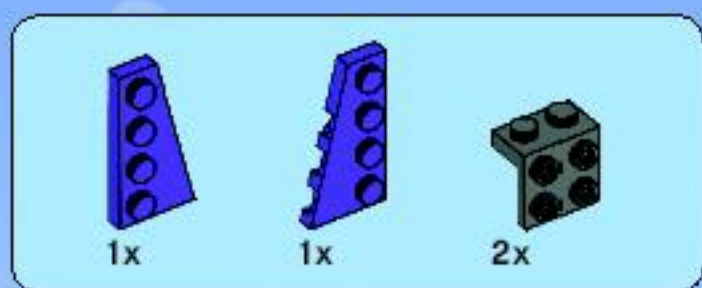

12

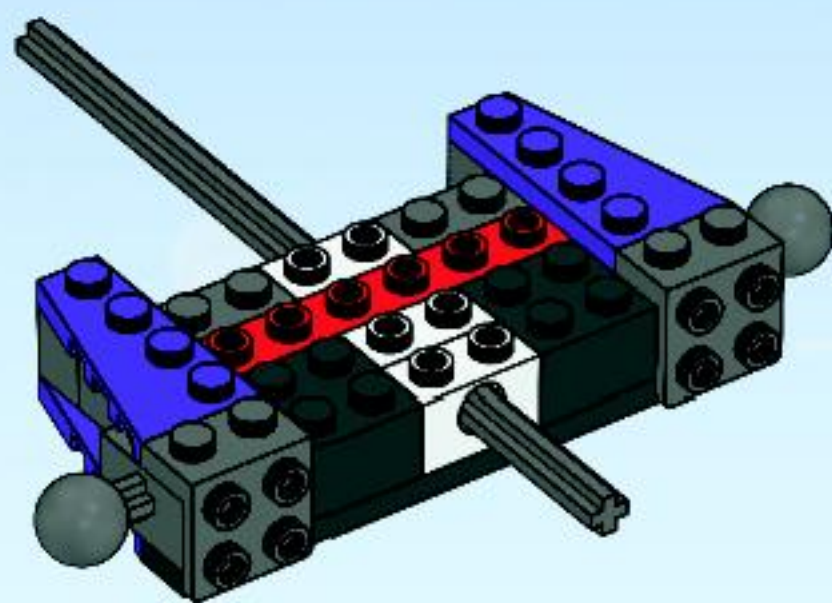



4x

# 13

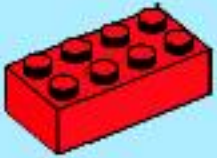
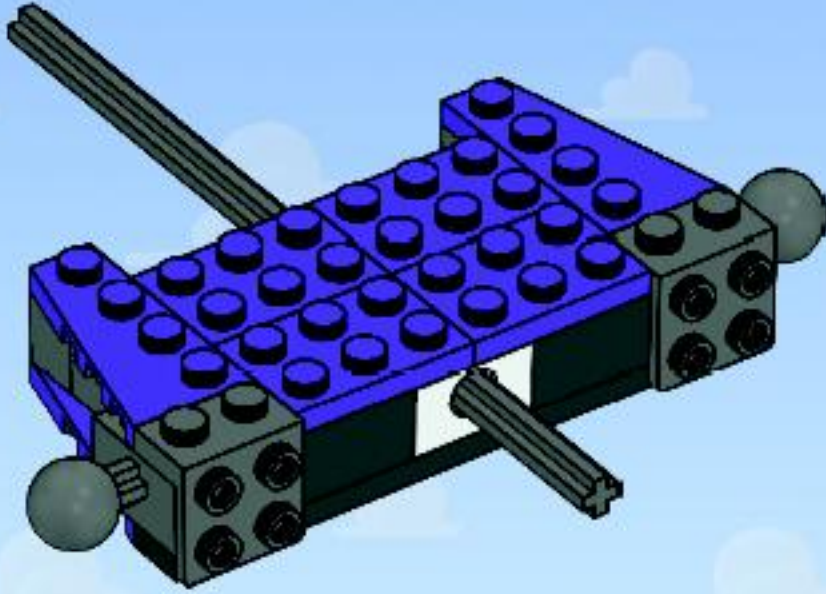

1x



1x

# 14

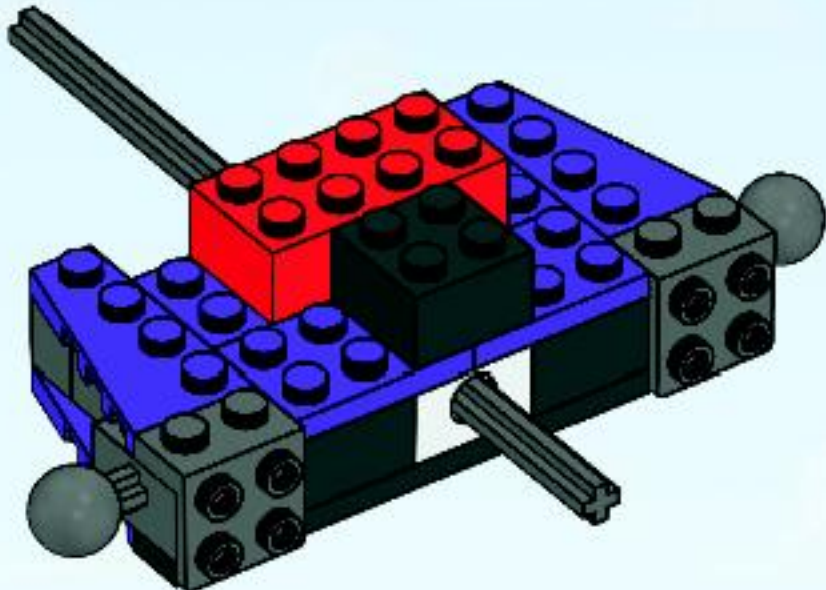





2x



2x

# 15

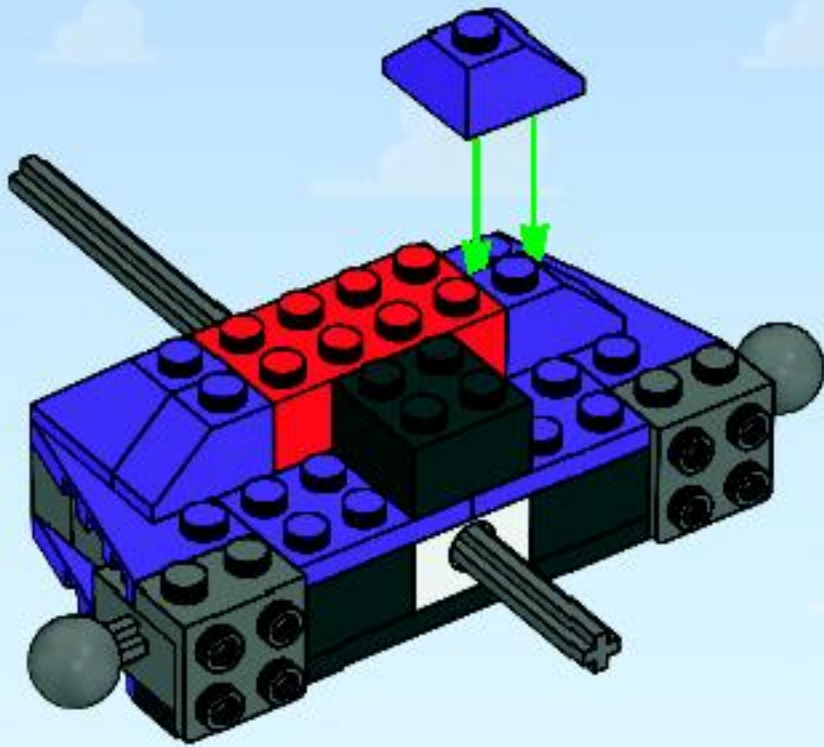





2x

# 16

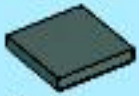
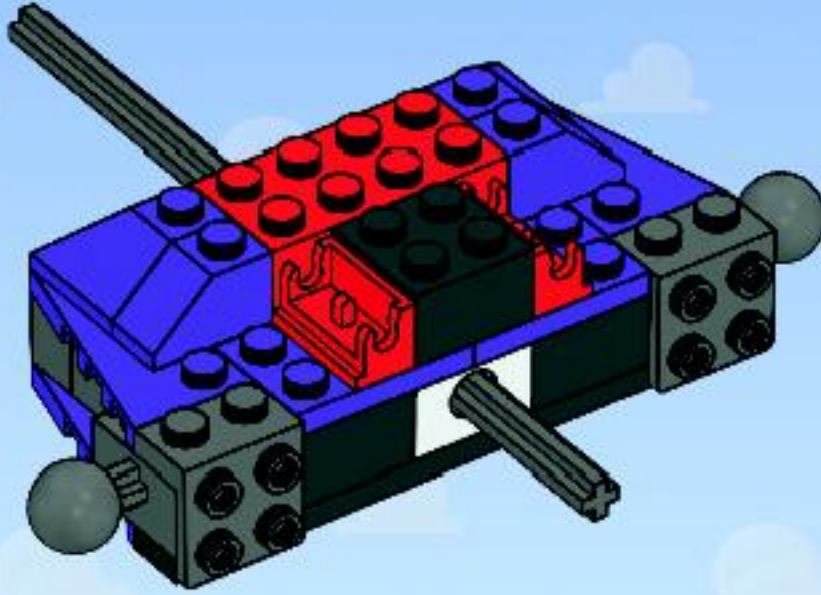

2x



2x

# 17

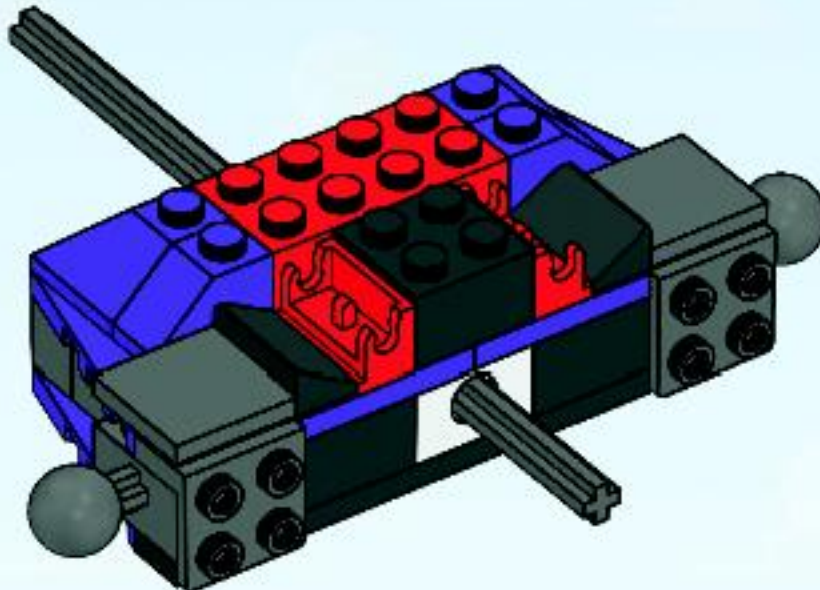



# 18

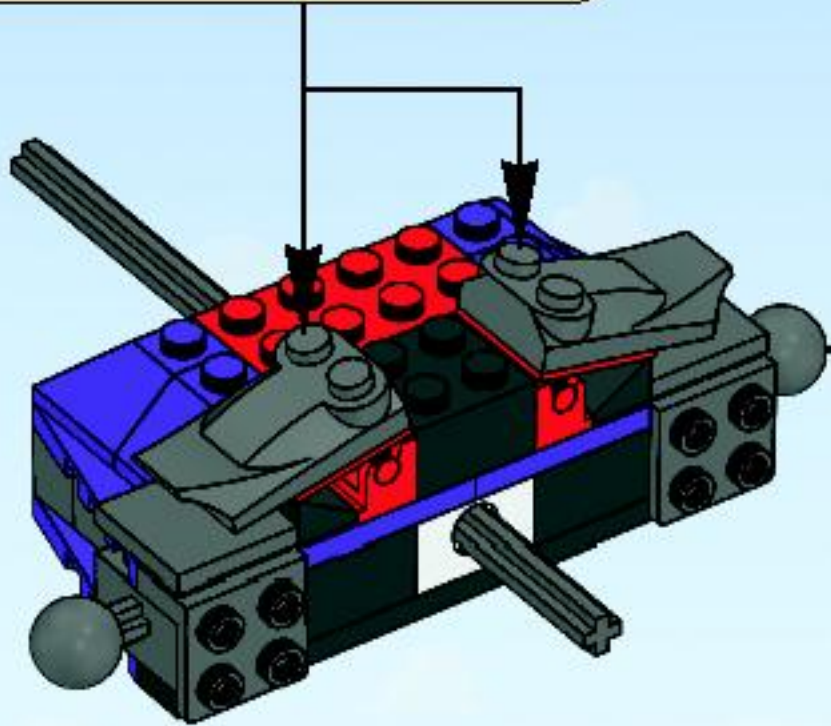
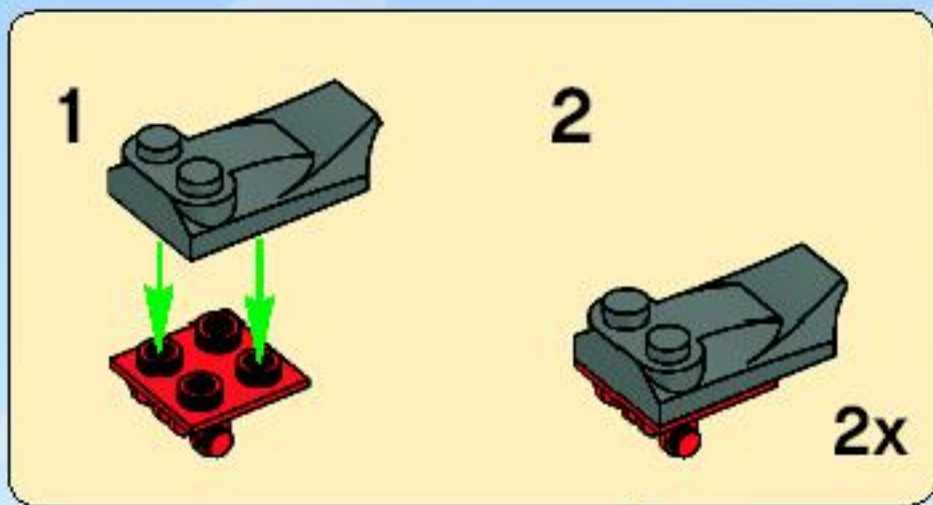



2x

# 19

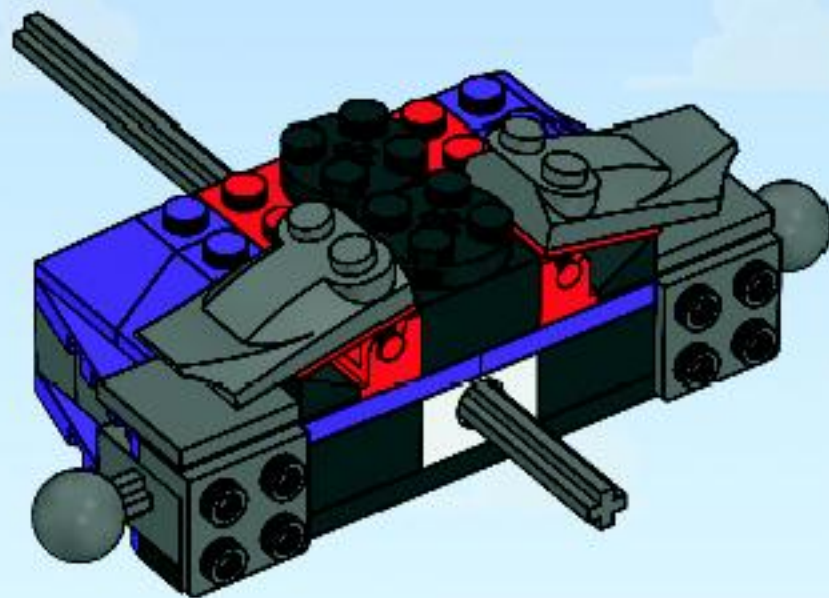



4x

20

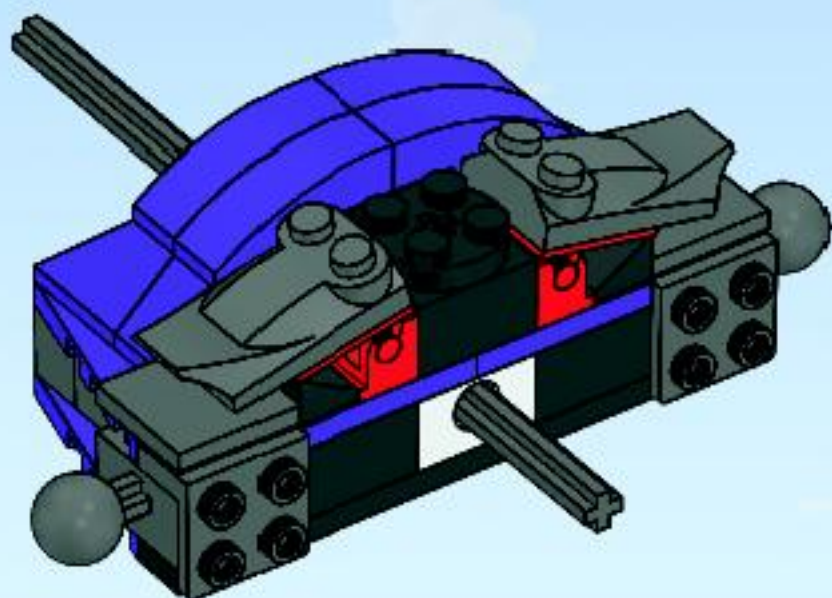





1x



1x

# 21

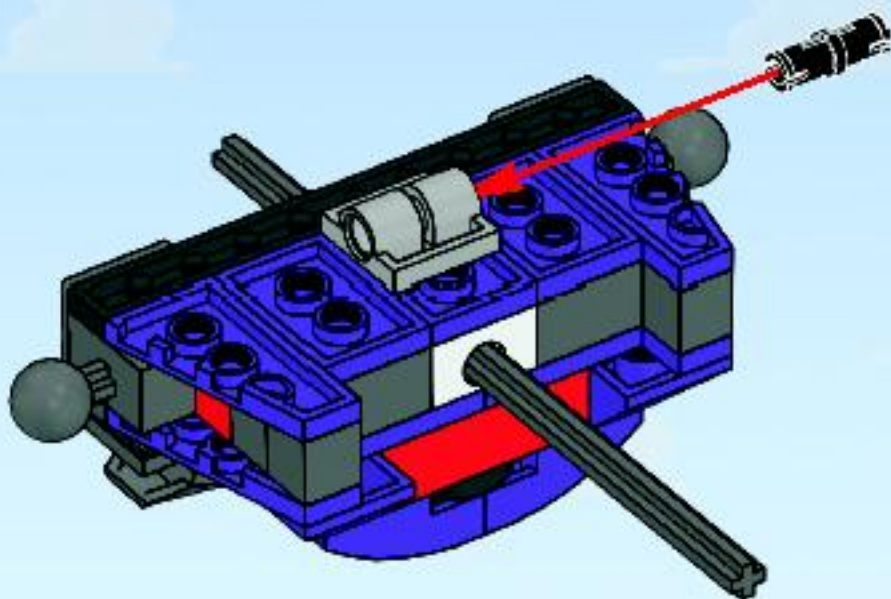



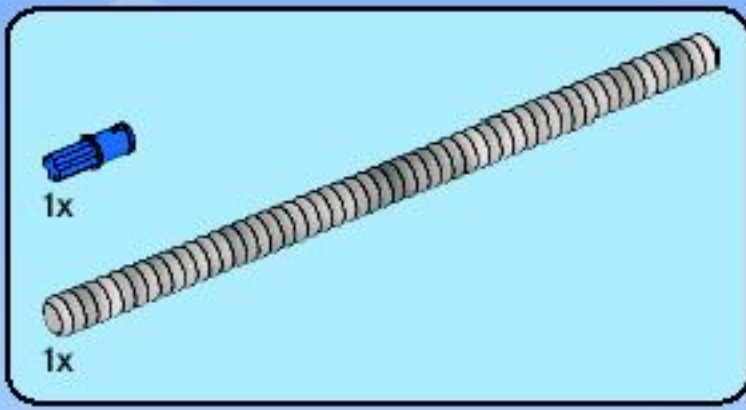

22

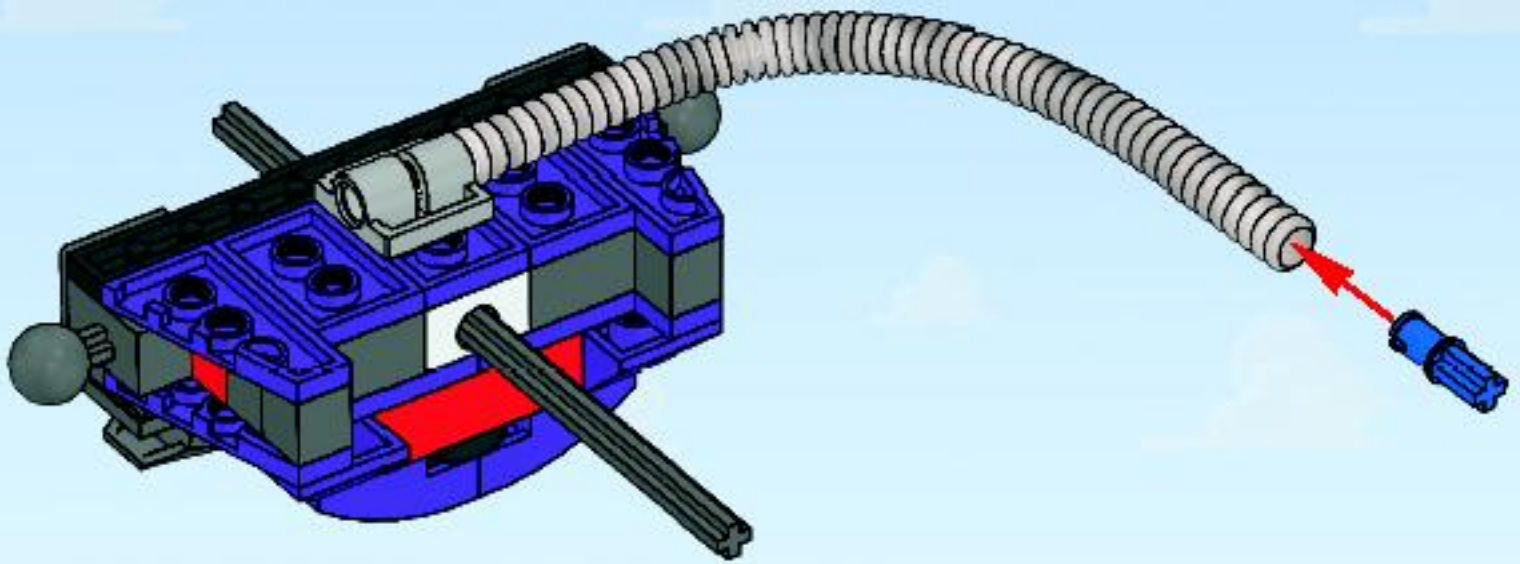



23

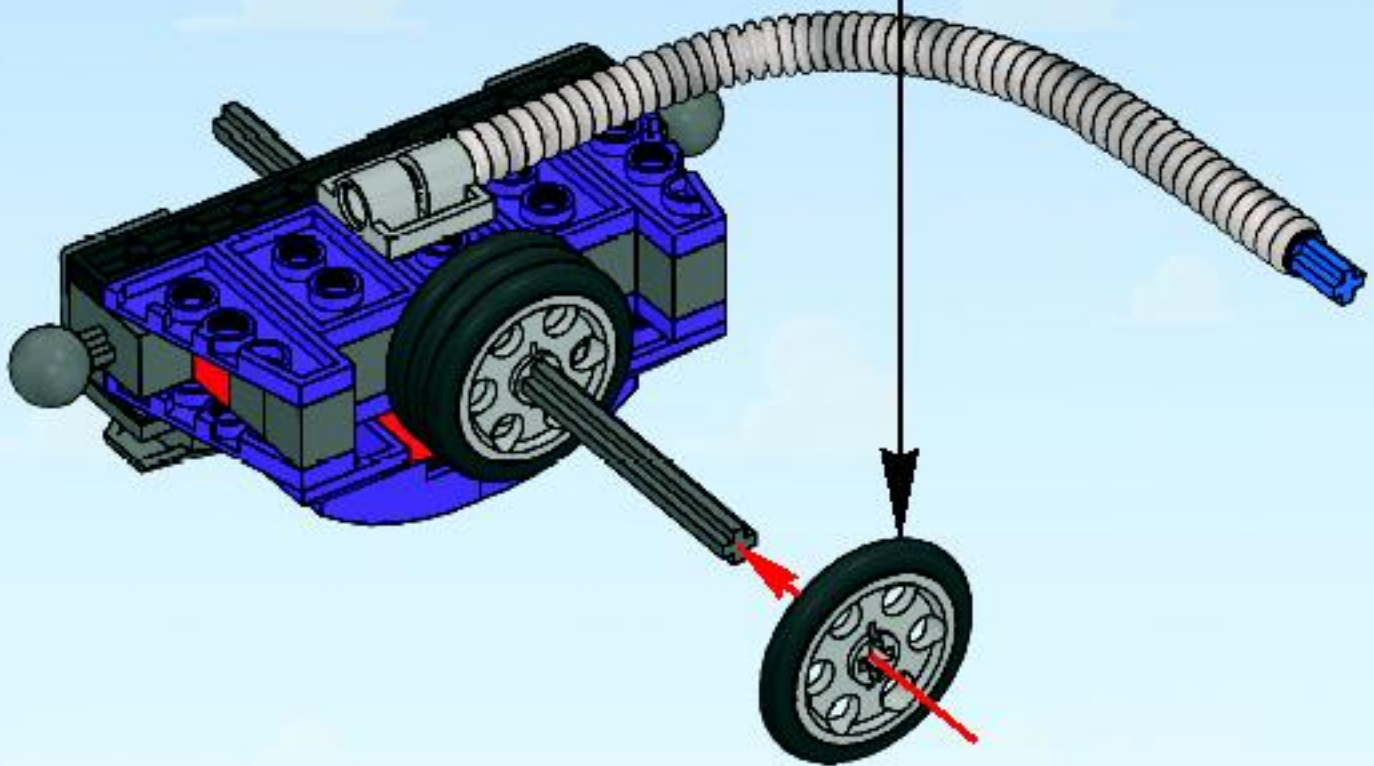
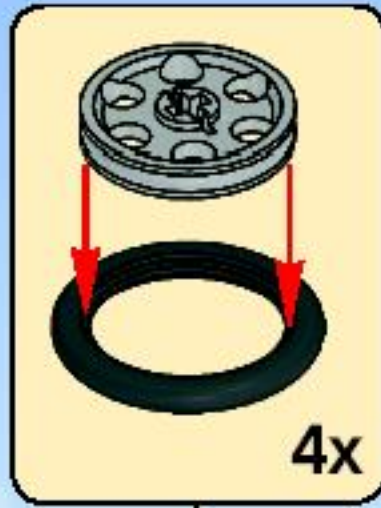

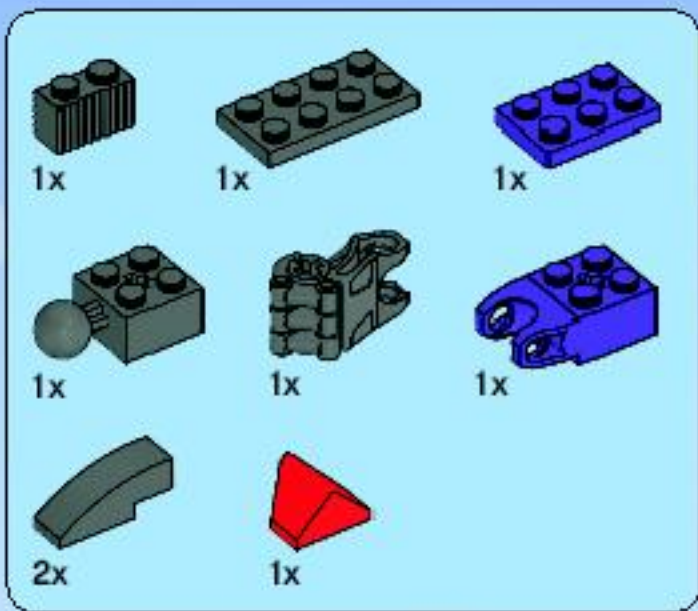
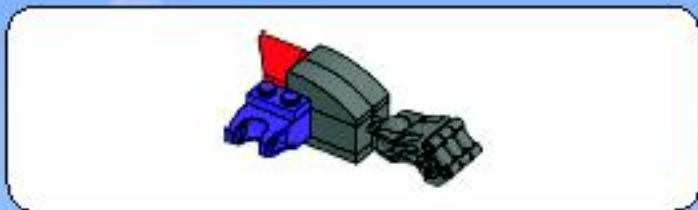

# 24

1

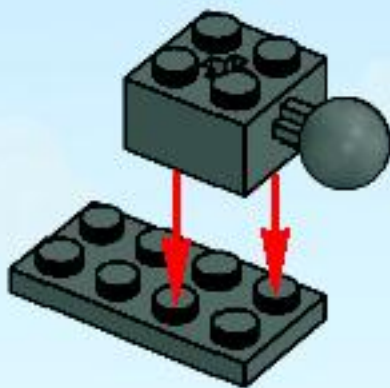

2

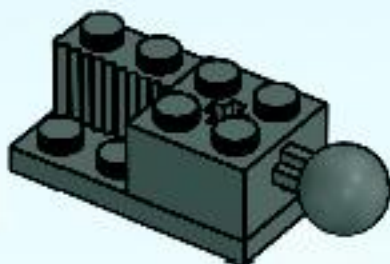

3



4



5

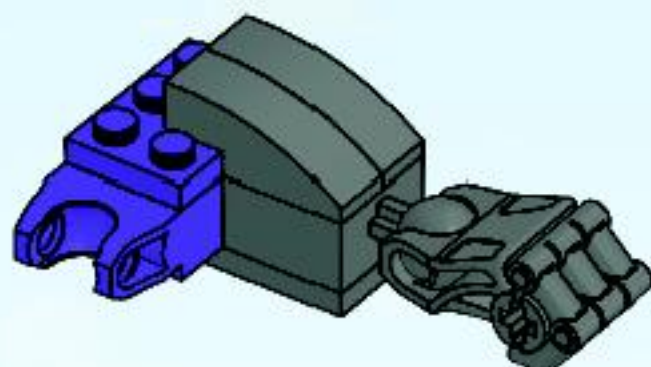



6

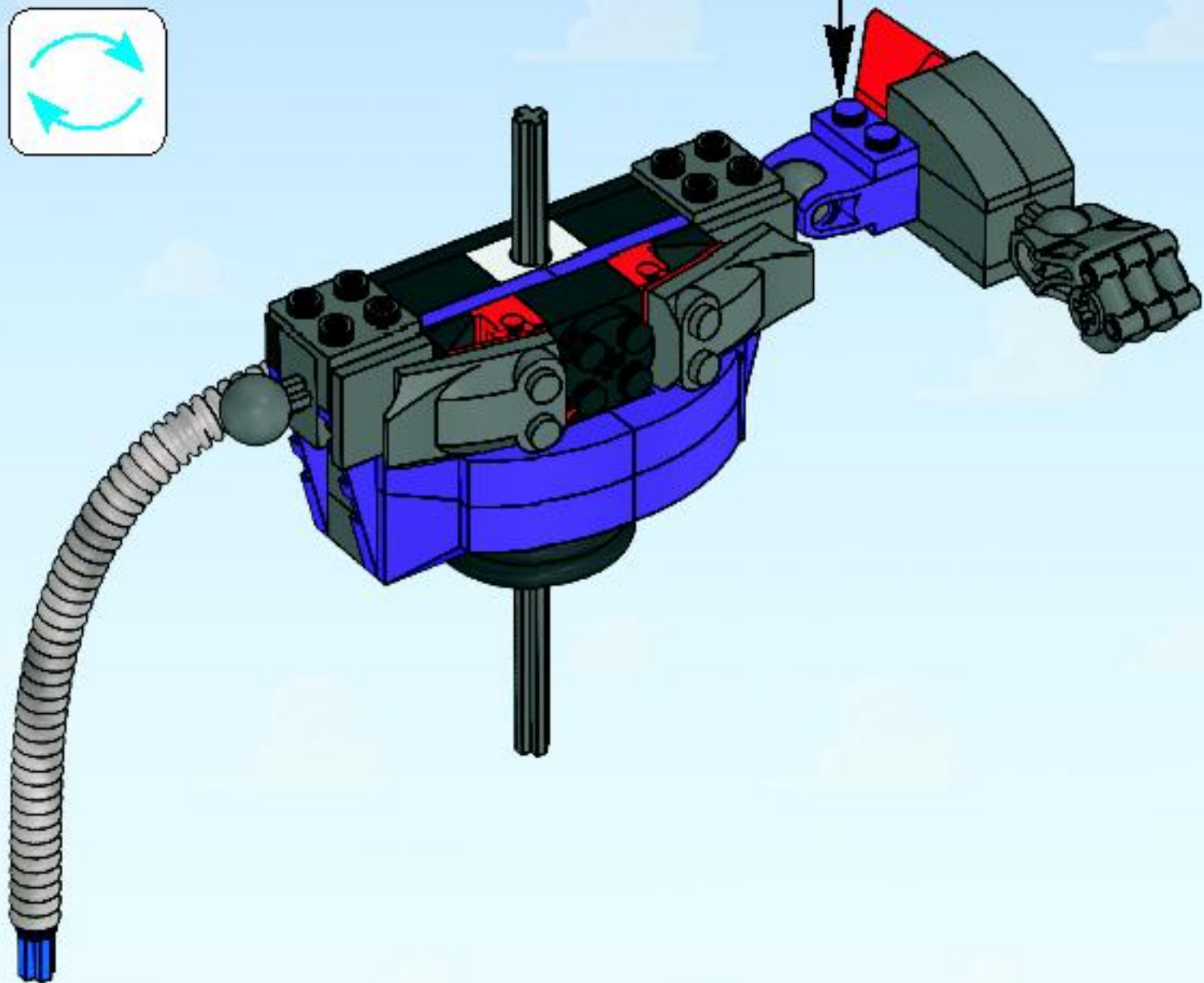
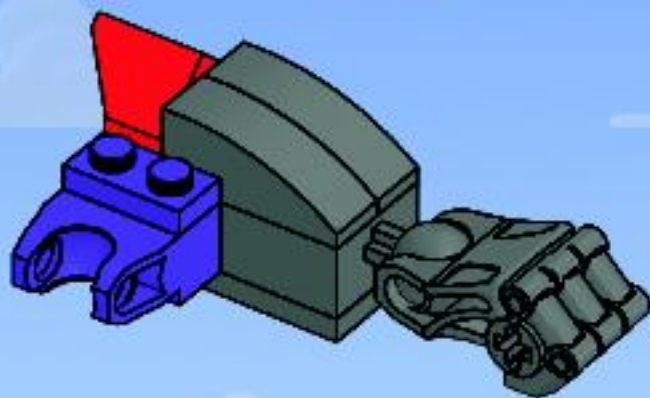

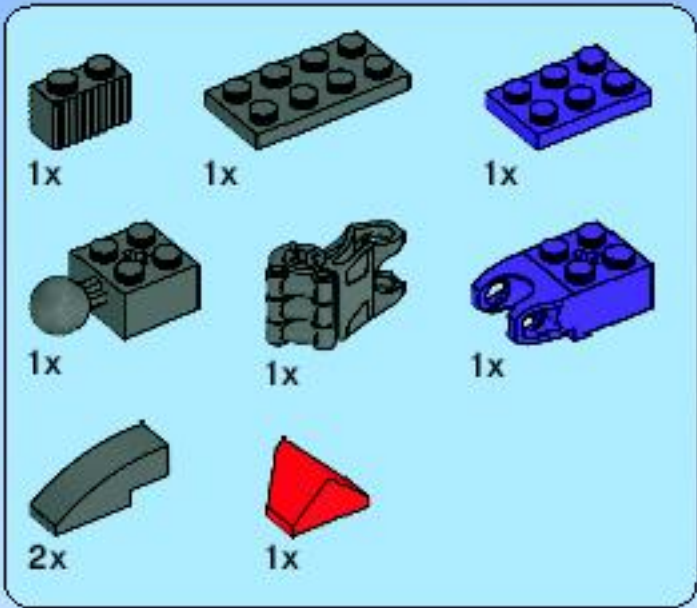
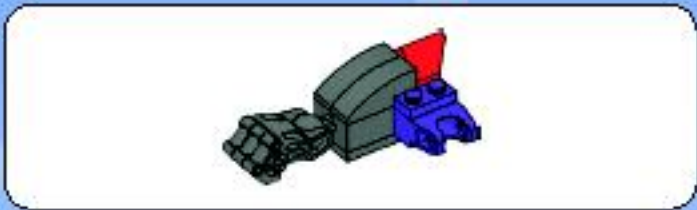

# 25

1

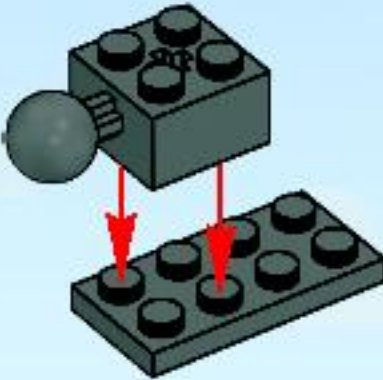

2

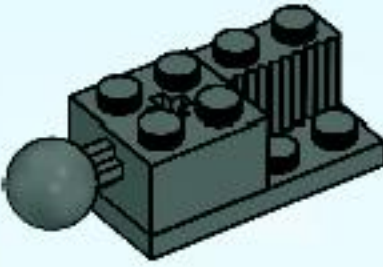

3



4

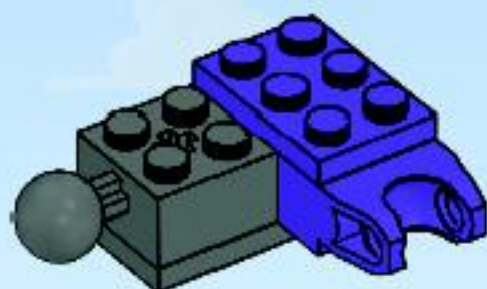

5

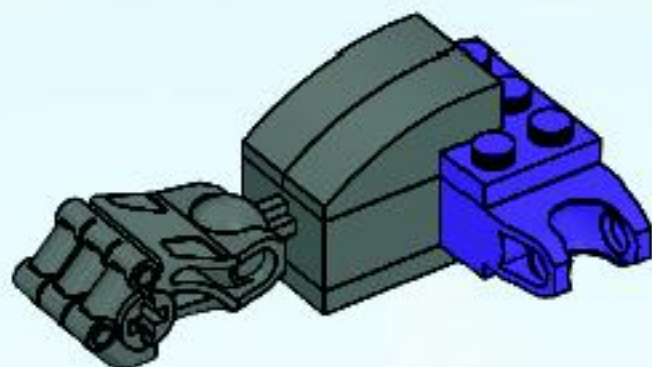

6

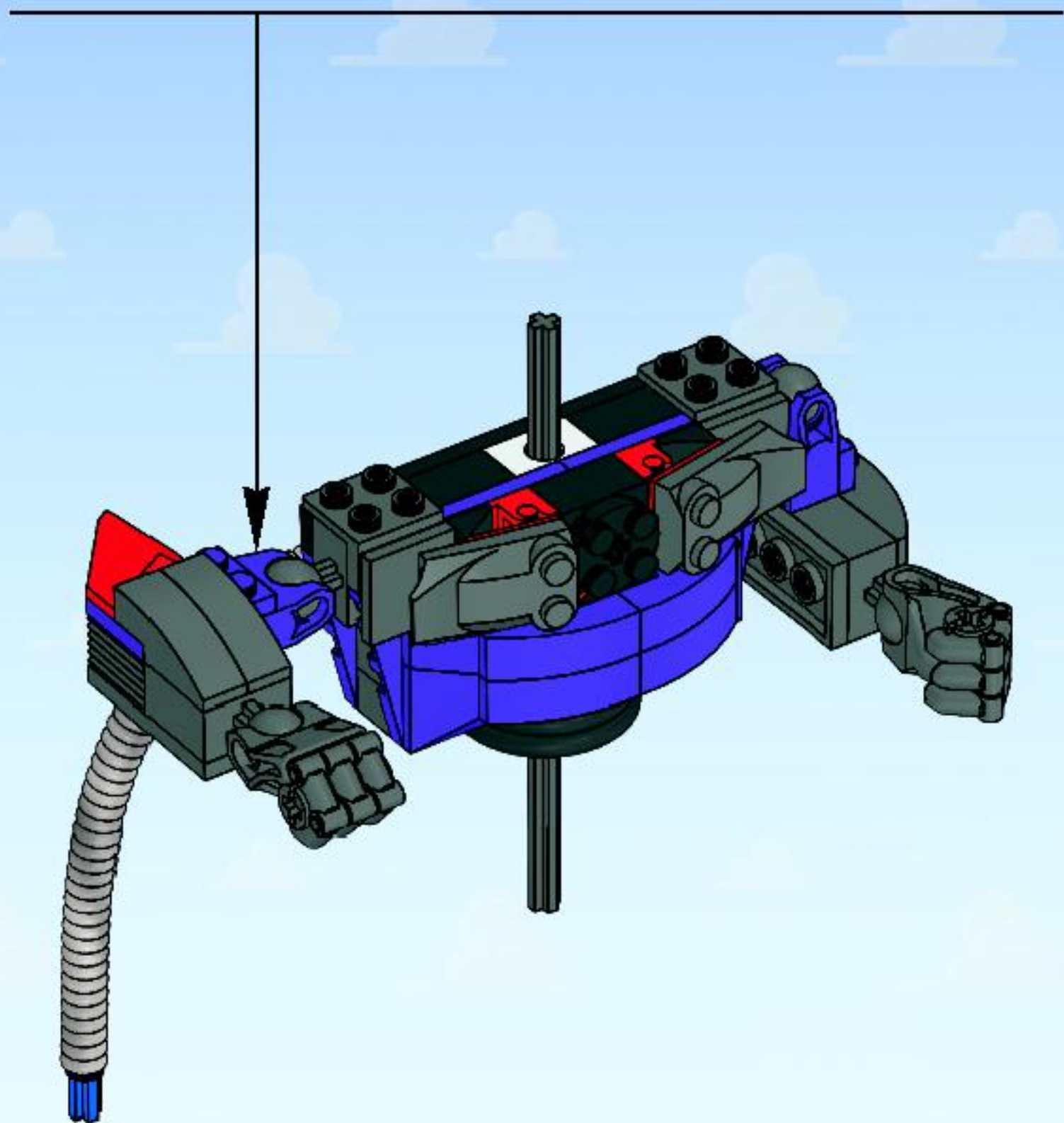
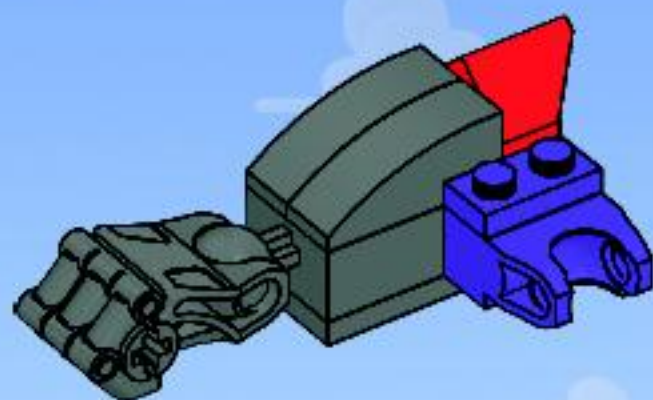





26

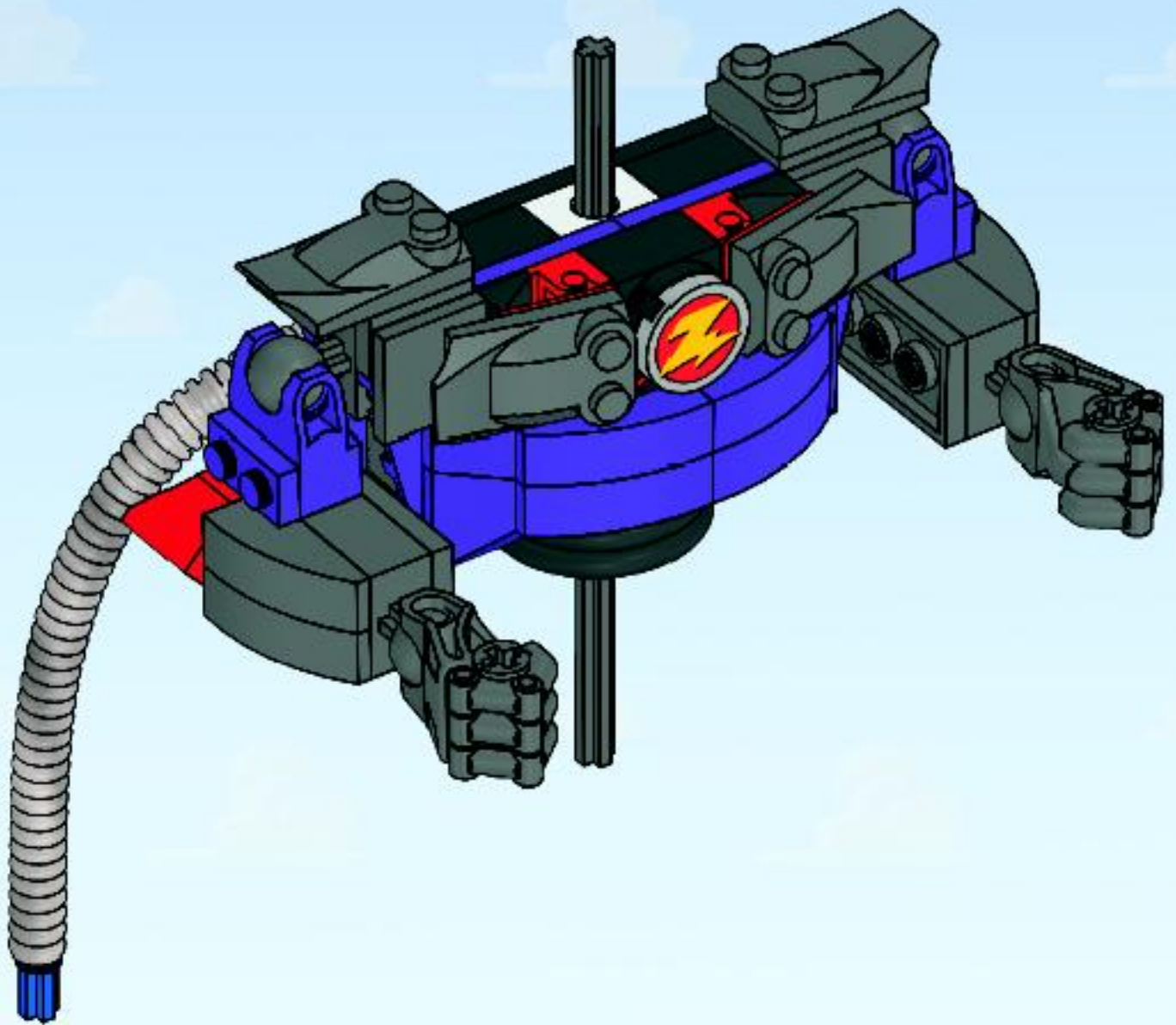

27

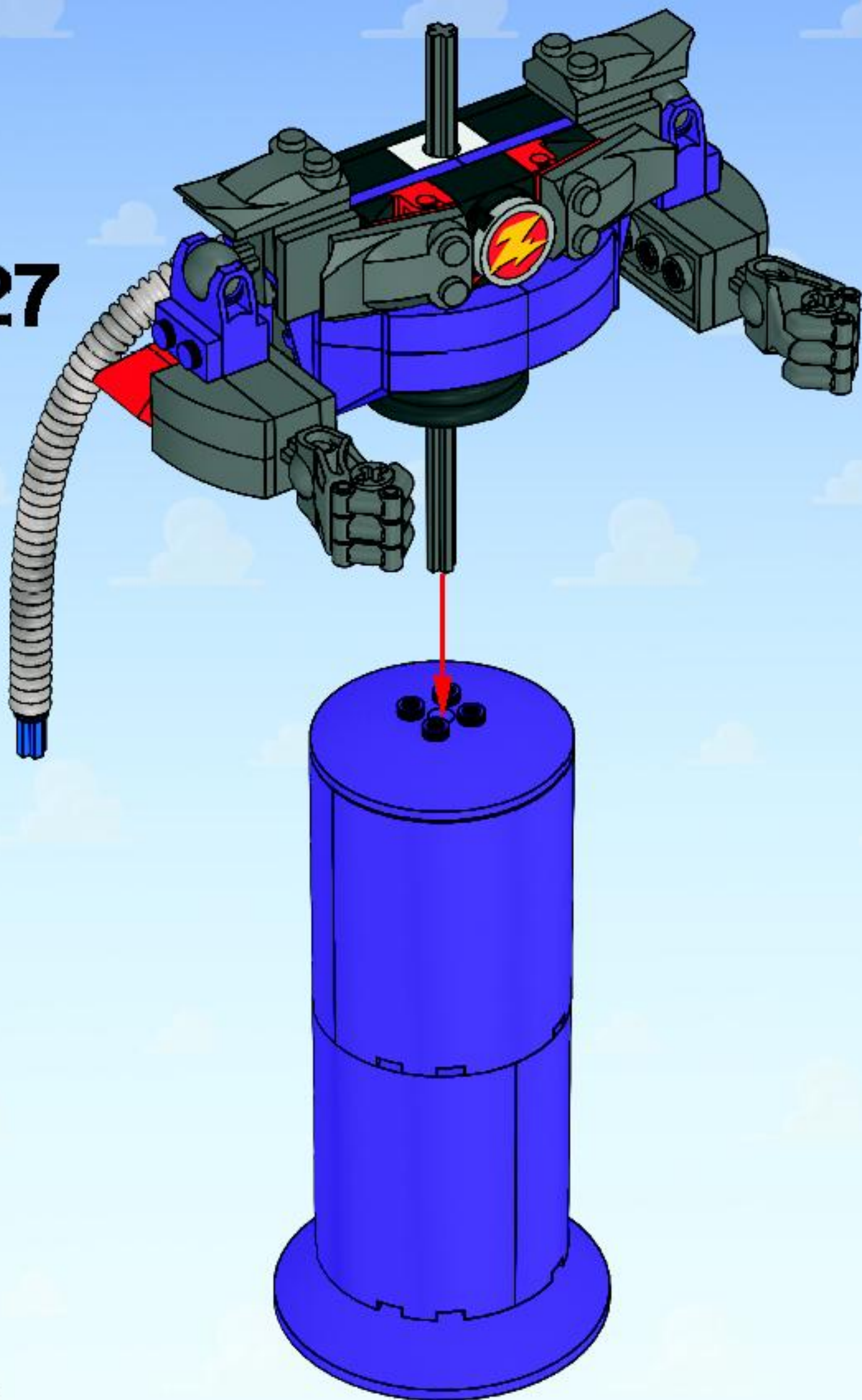

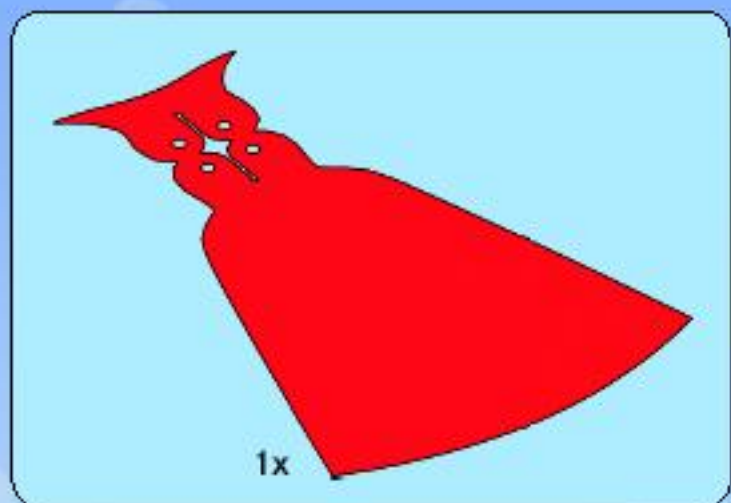

28

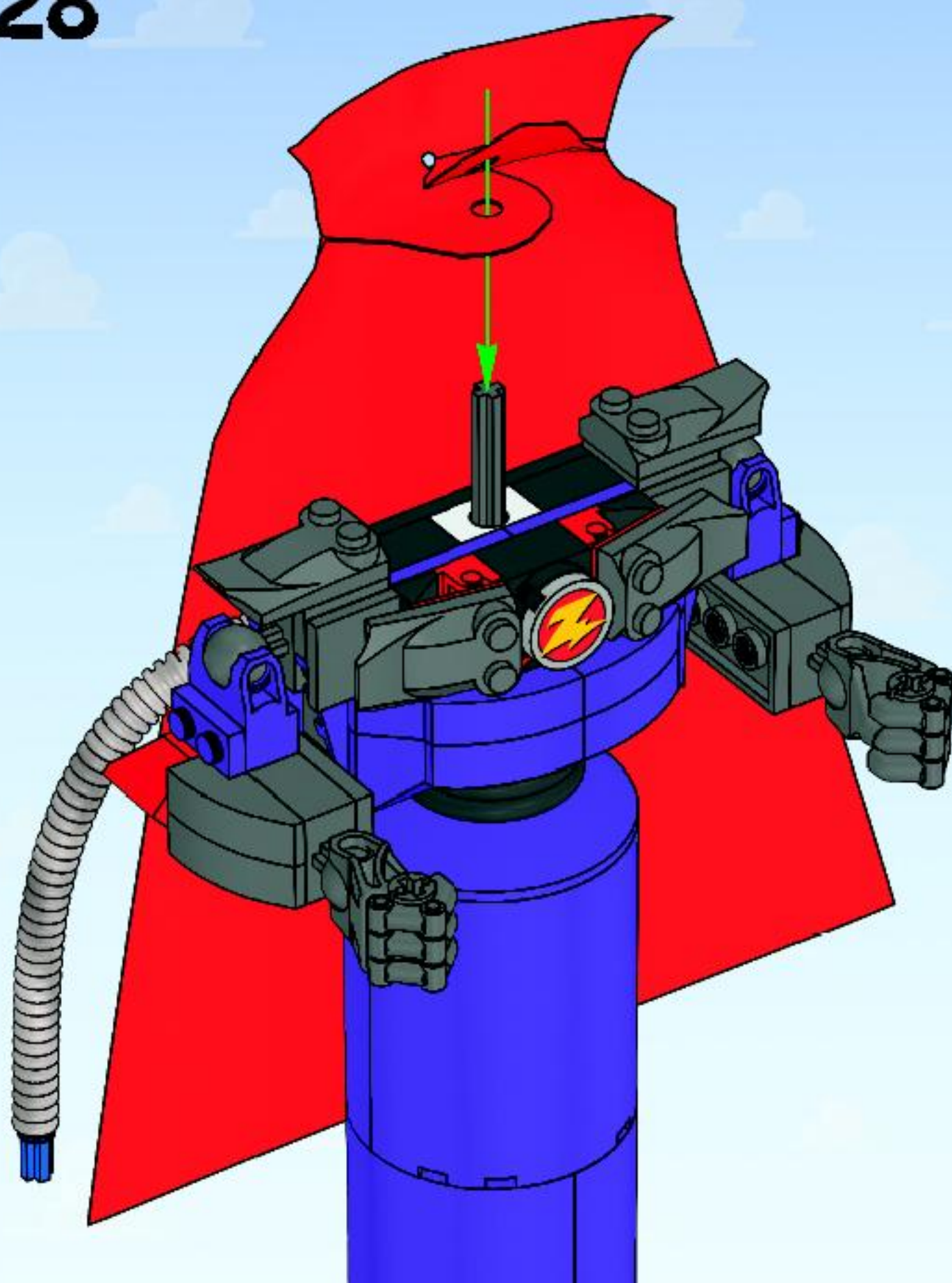





29

1



2





3

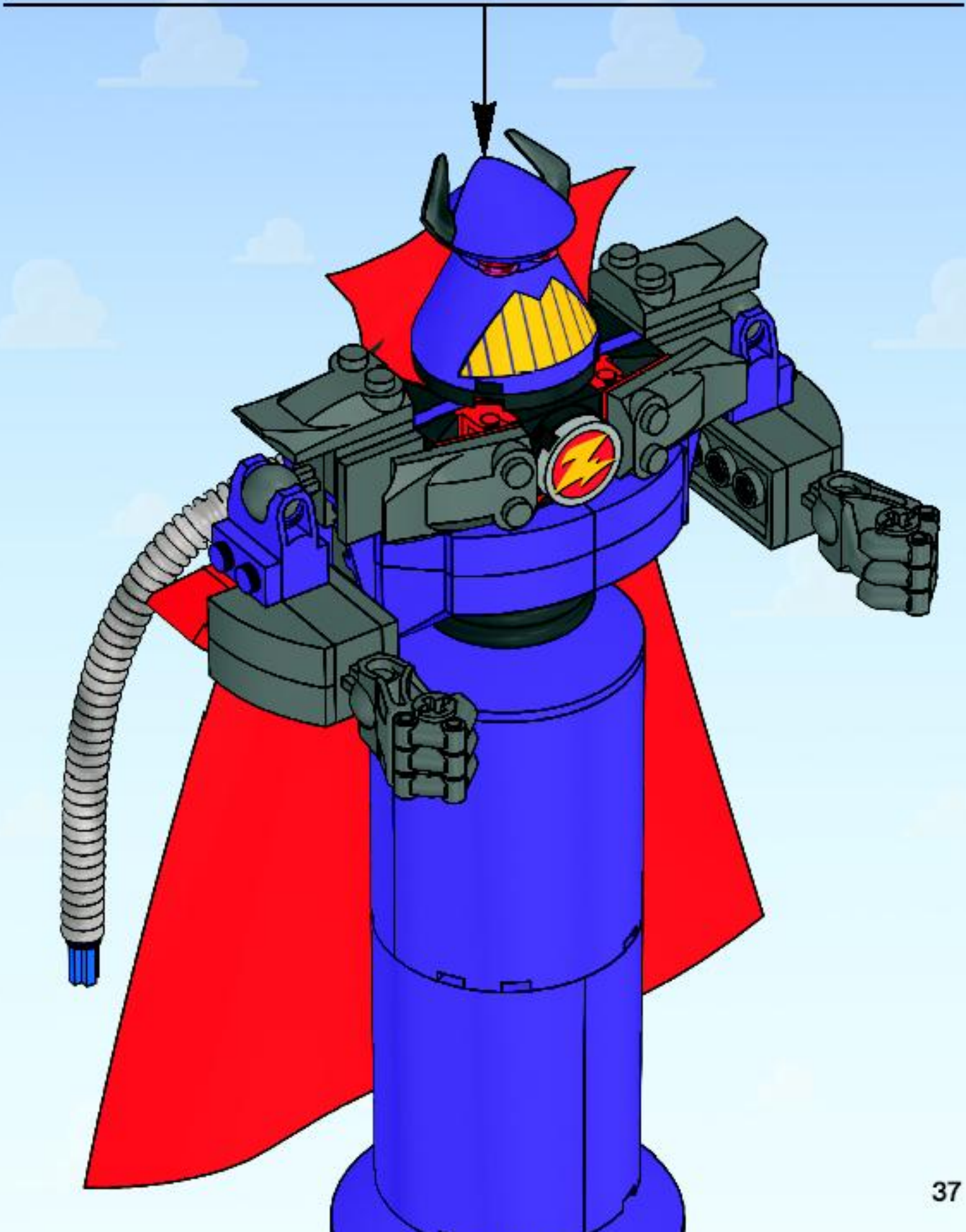



1

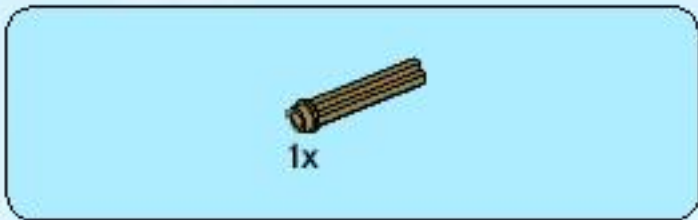

2

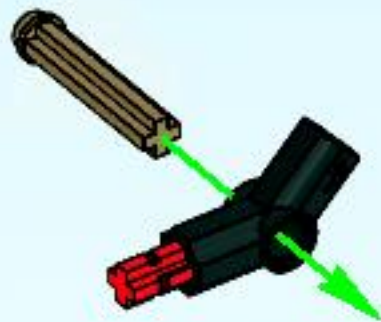



1x

3



1x



1x

4





5

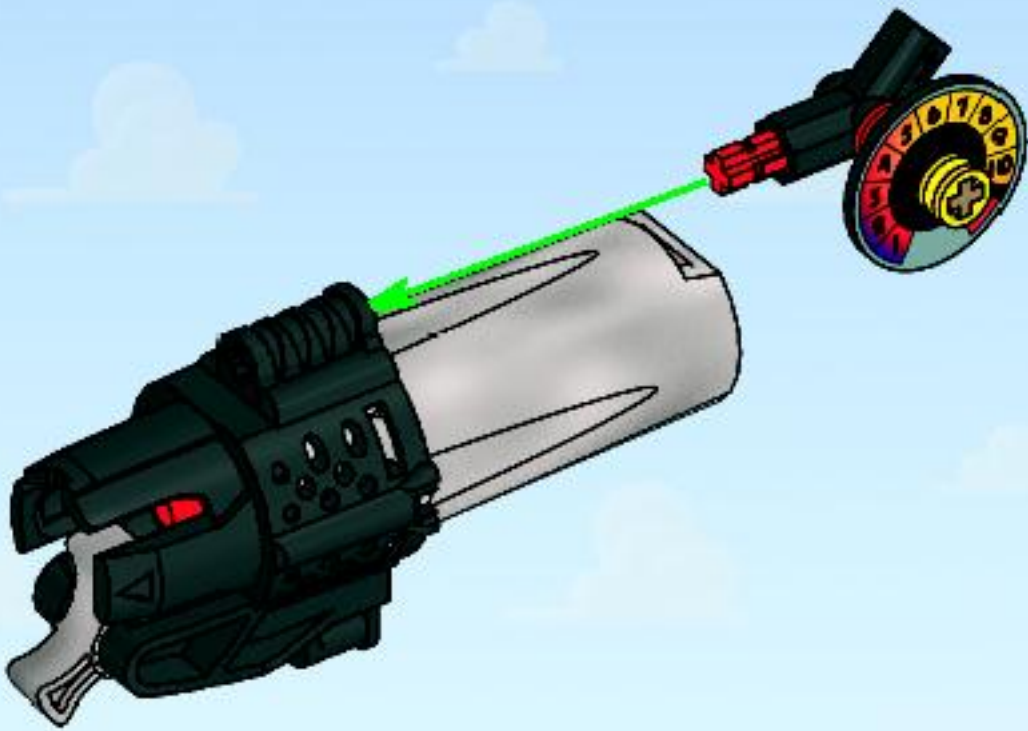





1x

6

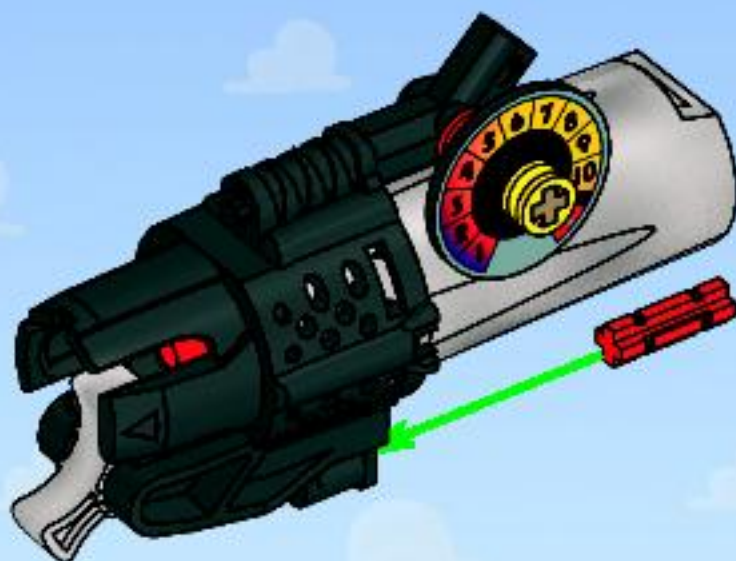

1x

7

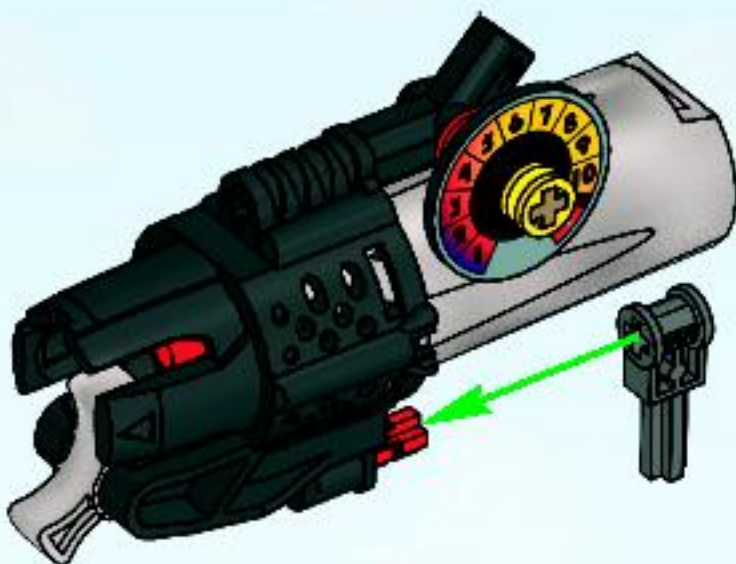

30

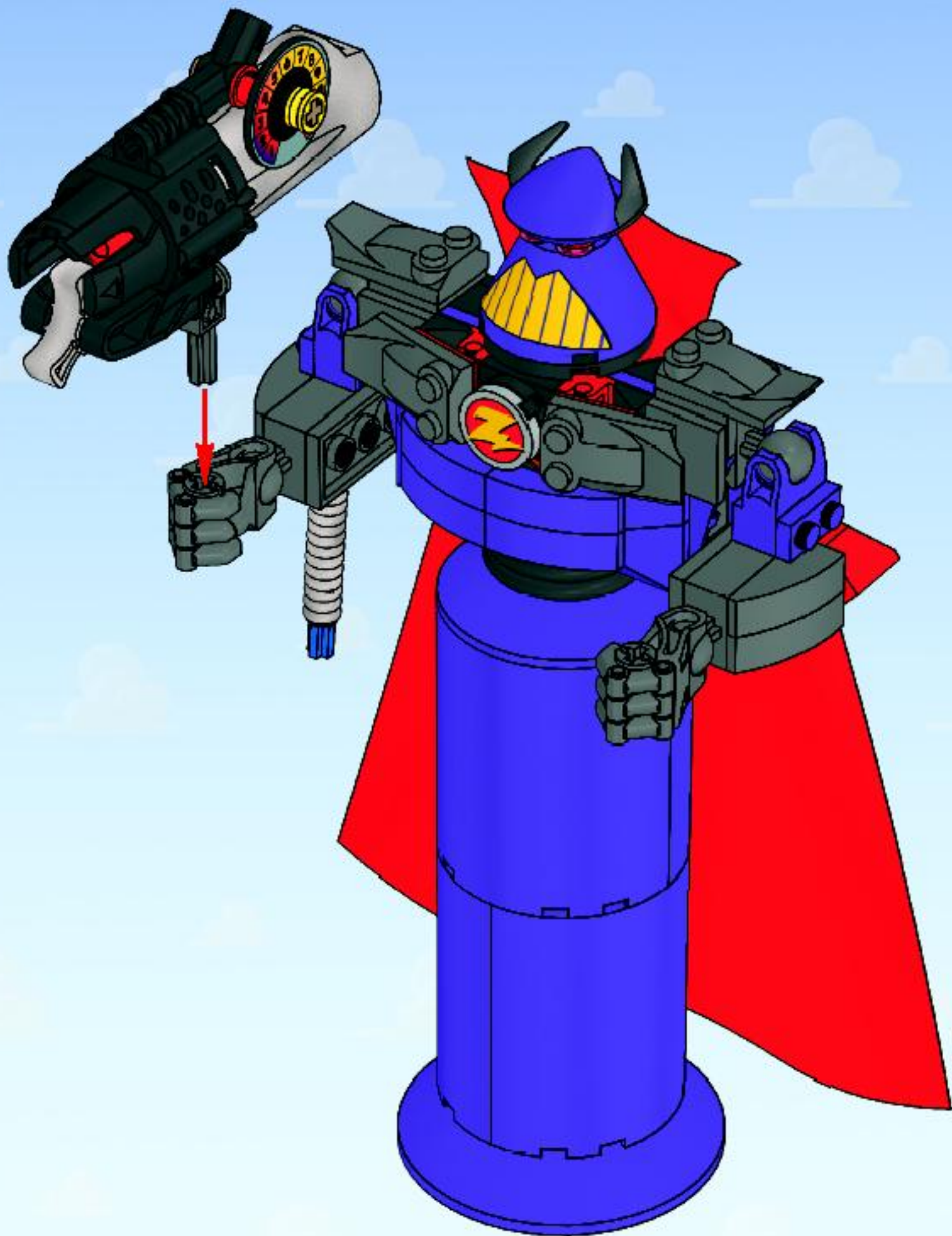



31





32









**7591**



**7592**





**7590**



**7595**







**7593**



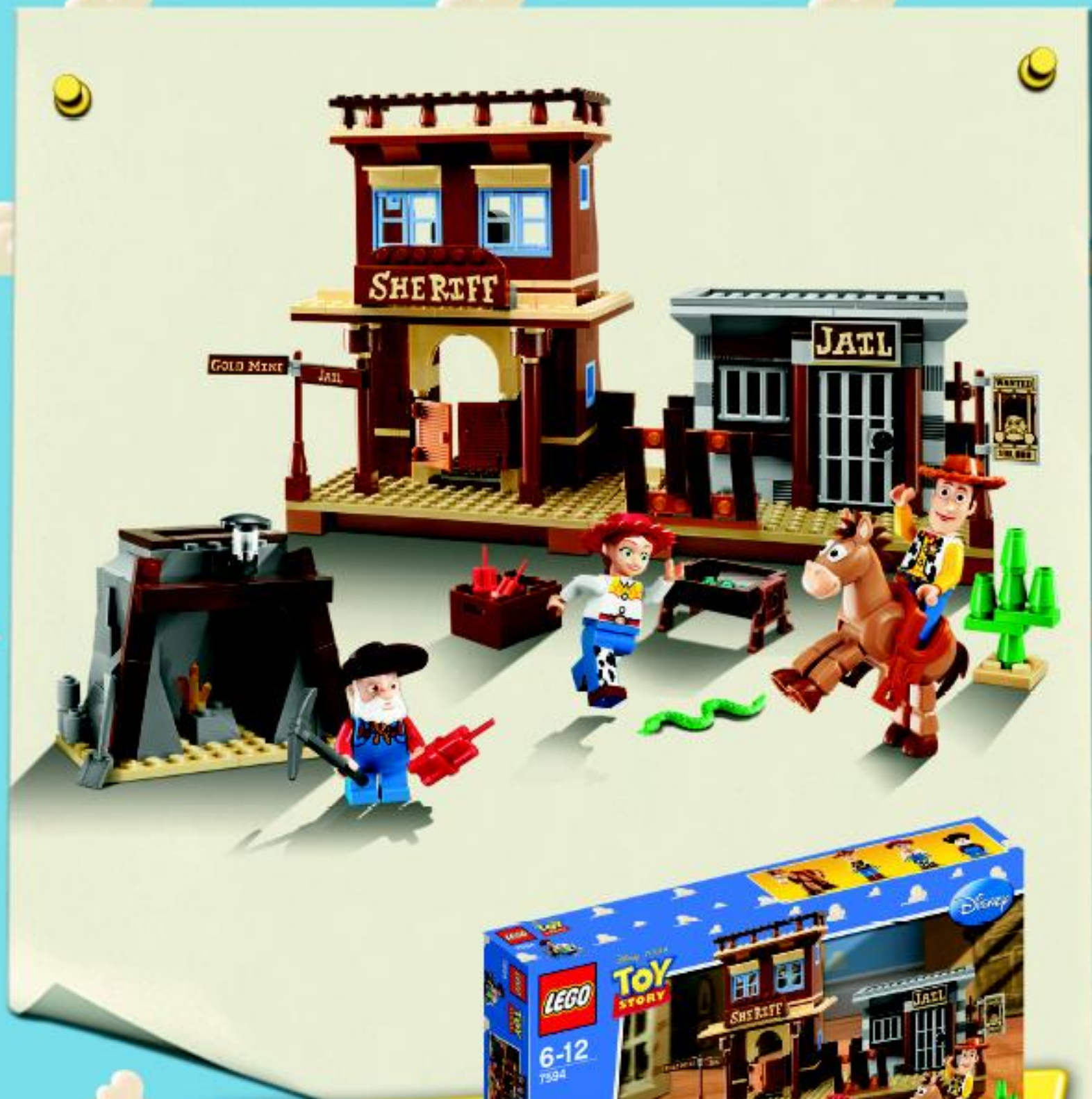

**7594**





Customer Service

Kundenservice

Service Consommateurs

Servicio Al Consumidor

[www.lego.com/service](http://www.lego.com/service) or dial



00800 5346 5555 :



1-800-422-5346 :





**FREE! GRATIS! GRATUIT!**



**club**  
MAGAZINE™

**www.LEGOclub.com**



**00800 5346 5555\***



**1-866-534-6258 • 1-877-518-5346**

US & Canada only

Canada seulement

\* Freephone. Mobile charges may apply. \* Numère sans frais. Les frais peuvent s'appliquer avec les téléphones cellulaires.  
\* Gebührenfrei, für den Anruf aus Mobilfunknetzen können Abwahlen. \* Gratis telefonnummer van vaste lijn.  
\* Nummer gratis nummer, når de ringer fra Postboks. \* Det er gratis, når du ringer fra Postboks.



**VISIT THE WORLD'S  
BIGGEST LEGO® SHOP!**

**www.LEGOshop.com**



1

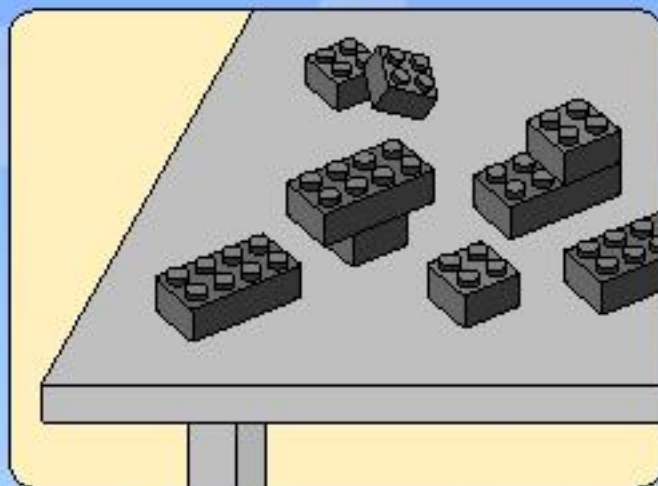

2

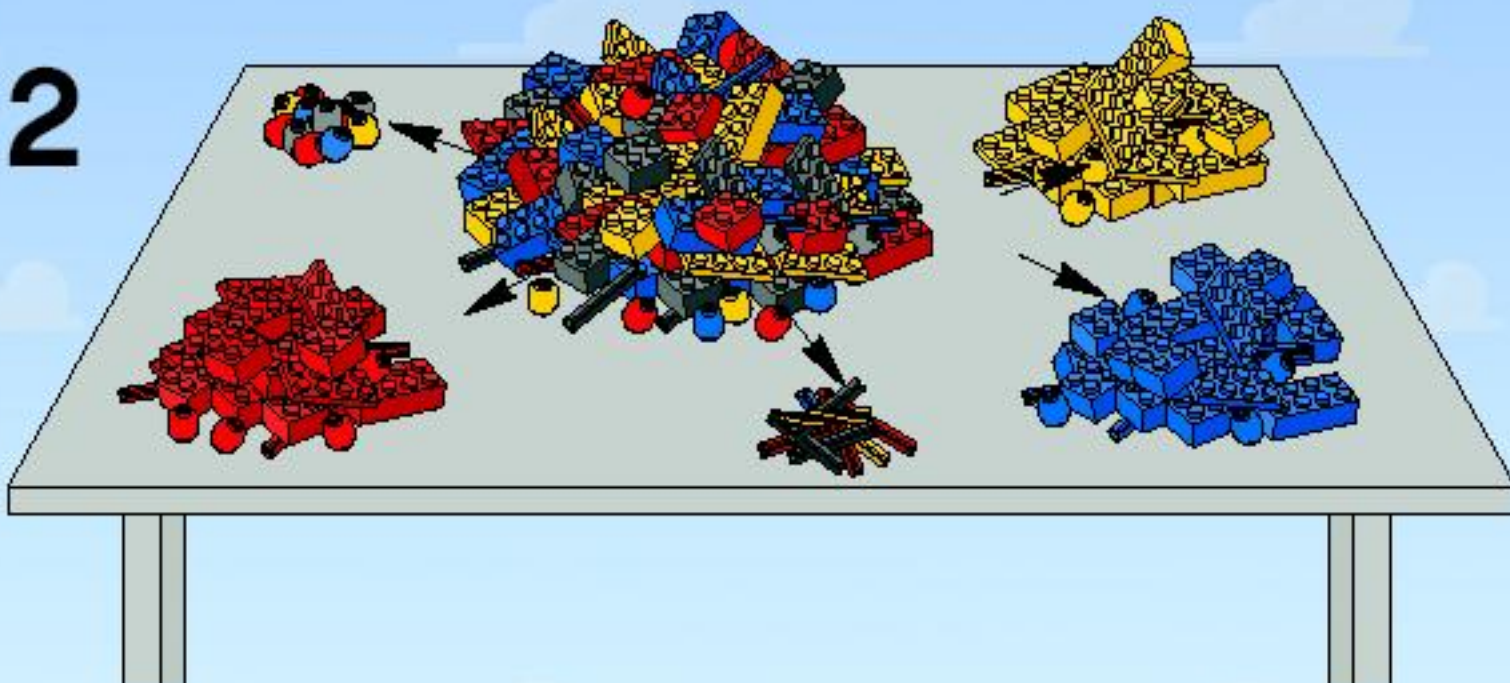

3

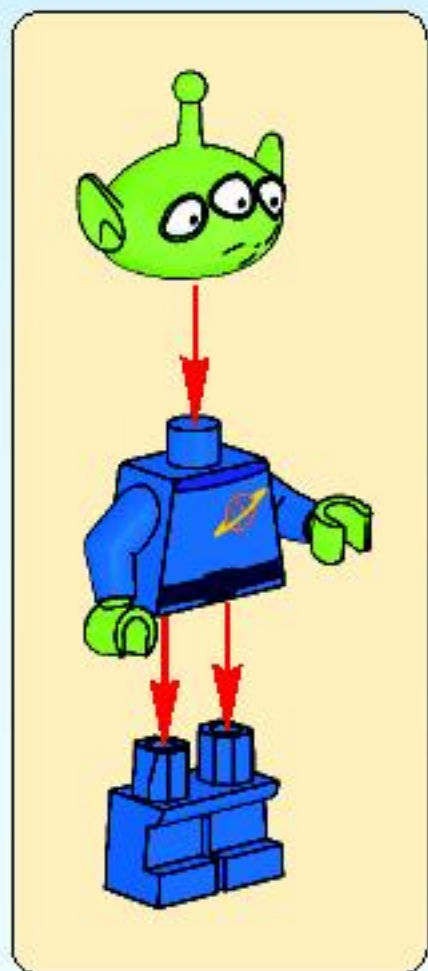





# WIN!

Go to [www.nielsen.com/LEGO](http://www.nielsen.com/LEGO)  
to fill out a survey for a chance  
to win a cool LEGO® Product.  
No purchase necessary.  
Open to all residents where not prohibited.



## [www.nielsen.com/LEGO](http://www.nielsen.com/LEGO)

### GEWINNE!

Nimm an der Umfrage auf [www.nielsen.com/LEGO](http://www.nielsen.com/LEGO) teil und hab die Chance ein cooles LEGO® Produkt zu gewinnen!  
Die Teilnahme am Gewinnspiel führt zu keinerlei Kaufverpflichtungen. Teilnahme in allen nicht ausgeschlossenen Ländern möglich.

### WIN!

Ga naar [www.nielsen.com/LEGO](http://www.nielsen.com/LEGO), vul een enquêteformulier in en maak kans op een cool LEGO® product.  
Geen aankoopverplichting.  
Iedereen mag deelnemen, uitgezonderd Ingezetenden van landen waar een enquêteverbod geldt.

### GAGNE!

Visite [www.nielsen.com/LEGO](http://www.nielsen.com/LEGO) pour répondre à un questionnaire et avoir une chance de gagner un produit LEGO® très cool!  
Aucune obligation d'achat.  
Ouvert à tous les résidents des pays autorisés.

### 当てよう!

[www.nielsen.com/LEGO](http://www.nielsen.com/LEGO) にアクセスして、アンケートにご記入ください。  
当選者にはレゴ製品を差し上げます。  
お買い上げの必要はありません。  
禁止されていない限り、すべての皆様にご利用いただけます。