



## WE'RE MAKING OUR PACKAGING MORE SUSTAINABLE

We're transitioning from single-use plastic to paper-based packaging. As we progress, you may find a mix of paper and plastic in our boxes.

## NOUS RENDONS NOS EMBALLAGES PLUS DURABLES

Nous passons des emballages en plastique à usage unique aux emballages à base de papier. Durant la transition, vous pourriez trouver un mélange de papier et de plastique dans nos boîtes.

## QUEREMOS HACER MÁS SUSTENTABLES NUESTROS MATERIALES DE EMBALAJE

Estamos cambiando las bolsas de plástico desechables por bolsas con base de papel. Conforme avanzamos en este propósito, puedes encontrar una mezcla de papel y de plástico en nuestras cajas.

[LEGO.com/sustainable-packaging](https://LEGO.com/sustainable-packaging)

# LEGO® VIP

- 1.** SIGN UP  
INSCRIVEZ-VOUS  
REGÍSTRATE

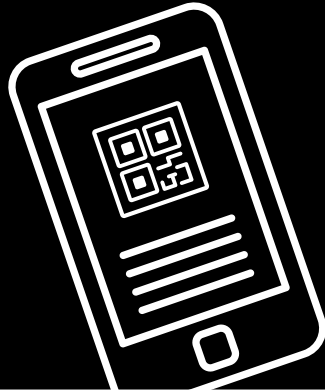

- 2.** EARN POINTS  
FOR PURCHASES  
GAGNEZ DES POINTS  
POUR VOS ACHATS  
GANA PUNTOS POR  
TUS COMPRAS



- 3.** REDEEM POINTS FOR REWARDS, EXPERIENCES,  
DISCOUNTS & MORE  
ÉCHANGEZ DES POINTS CONTRE DES RÉCOMPENSES,  
DES EXPÉRIENCES, DES RÉDUCTIONS ET PLUS ENCORE  
CANJEA PUNTOS POR RECOMPENSAS, EXPERIENCIAS,  
DESCUENTOS Y MUCHO MÁS

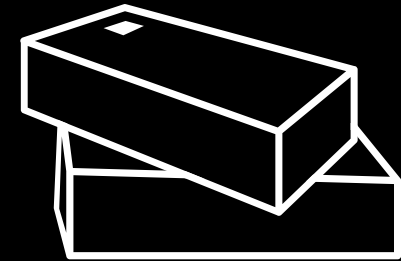
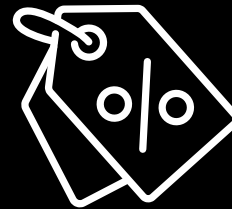

## WELCOME TO LEGO® ART

● From humble roots in pulp prints to a **cultural phenomenon** – the comic book genre has continually transformed storytelling through art. With innovative use of **graphic design** and **printing techniques**, **complex storylines** and **strongly defined characters**, it continues to influence pop art and other media. And now, for the fans, we're taking it **one step further** – create your own **Spider-Man comic panel** and immerse yourself in the **LEGO® Art experience**. PS: Don't miss the **amazing Soundtrack!**

## BIENVENUE À LEGO® ART

● Depuis ses humbles débuts dans les imprimés de pâte à papier jusqu'au **phénomène culturel**, la bande dessinée n'a cessé de transformer la narration par l'art. Grâce à l'utilisation innovante du **graphisme** et des **techniques d'impression**, à des **scénarios complexes** et à des **personnages bien définis**, elle continue d'influencer le pop art et d'autres médias. Et maintenant, pour les passionnés, nous allons **encore plus loin** – créez votre propre **bande dessinée Spider-Man** et plongez dans l'expérience **LEGO® Art**. PS : Ne manquez pas l'incroyable **bande sonore !**

## TE DAMOS LA BIENVENIDA A LEGO® ART

● Desde su humilde origen en las impresiones comerciales en masa hasta convertirse en un **fenómeno cultural**, el género del cómic ha transformado continuamente la narración de historias mediante el arte. Con un uso innovador del **diseño gráfico** y las **técnicas de impresión**, **argumentos complejos** y **personajes sólidamente definidos**, sigue influyendo en el arte pop y otros medios. Y ahora, pensando en los fans, vamos **un paso más allá** ofreciéndote la oportunidad de crear tu propio **panel de cómic de Spider-Man** y sumergirte en la experiencia **LEGO® Art**. P. D.: ¡No te pierdas la **increíble banda sonora!**



# APPLYING THE BEN DAY PROCESS

## APPLIQUER LE PROCÉDÉ BEN DAY

## EL PROCESO BEN-DAY EN LA PRÁCTICA

● **Did you know?** Comic books released between the 1930s and 1980s were often printed with techniques inspired by the **Ben Day process**. Developed for **newspaper comic strips** in 1879 – by illustrator and painter Benjamin Henry Day Jr. – the technique adds areas of color to black and white prints by spacing **grids of colored dots or lines**. Originally used to **save ink** and **reduce costs**, the Ben Day process has inspired generations of artists.

● **Le saviez-vous ?** Les bandes dessinées parues entre les années 1930 et 1980 étaient souvent imprimées avec des techniques inspirées du **procédé Ben Day**. Développée pour les **bandes dessinées des journaux** en 1879 par l'illustrateur et peintre Benjamin Henry Day Jr., cette technique ajoute des zones de couleur aux impressions en noir et blanc en espaçant des **grilles de points ou de lignes colorées**. Utilisé à l'origine pour **économiser l'encre** et **réduire les coûts**, le procédé Ben Day a inspiré des générations d'artistes.

● **¿Lo sabías?** Los cómics publicados entre las décadas de 1930 y 1980 con frecuencia se imprimían usando técnicas inspiradas en el **proceso Ben-Day**. Desarrollada para las **tiras cómicas de los periódicos** en 1879 por el ilustrador y pintor Benjamin Henry Day Jr., la técnica añade color a las impresiones en blanco y negro espaciando **cuadrículas de puntos o líneas de distintos tonos**. Originalmente utilizado para **ahorrar tinta** y **reducir costos**, el proceso Ben-Day ha servido para inspirar a generaciones de artistas.

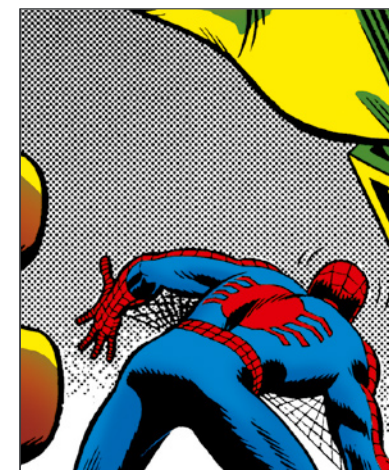
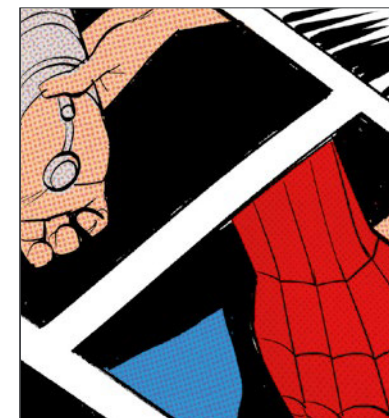
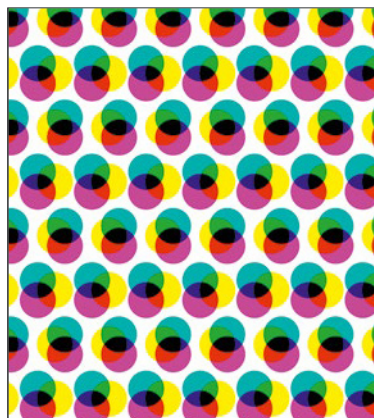

Ben Day-inspired  
mid-century  
pop art

Le pop art du milieu  
du siècle inspiré par  
Ben Day  
Arte pop de mediados  
de siglo inspirado en  
la técnica Ben-Day

The technique  
recreated with  
LEGO® elements

La technique  
recréée avec des  
éléments LEGO®

La técnica  
recreada con  
elementos LEGO®

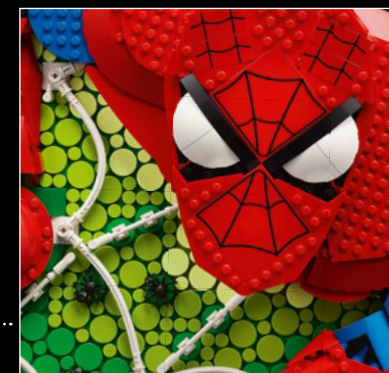

# 1962

## ALONG CAME A SPIDER UNE ARAIGNÉE EST APPARUE TRAJO UNA ARAÑA CONSIGO

● **Peter Parker** --- loveably awkward, gangly teen/friendly neighborhood super hero --- first appeared in the August 1962 issue of **AMAZING FANTASY #15**. The character won the hearts of Marvel fans and soon featured in his first independent comic book **THE AMAZING SPIDER-MAN (1963) #1**. Written by comic book icon **Stan Lee** and illustrated by **Steve Ditko** and **Sol Brodsky**, the story follows Peter shortly after the death of his beloved **uncle Ben**.

**The Amazing Spider-Man** continues to weave a web of **dedicated fans** all over the world - Six decades on, he has starred in over **900** AMAZING SPIDER-MAN comic books, plus features, annuals, collections, newspaper strips, films, games, plays, TV series and more.

● **Peter Parker**, un ado adorablement maladroit et dégingandé ainsi que le sympathique super héros du quartier, est apparu pour la première fois dans le numéro d'août 1962 d'**AMAZING FANTASY #15**. Le personnage a gagné le cœur des passionnés de Marvel et a rapidement figuré dans son premier livre de bandes dessinées indépendant **THE AMAZING SPIDER-MAN (1963) #1**. Écrit par l'icône de la bande dessinée **Stan Lee** et illustré par **Steve Ditko** et **Sol Brodsky**, l'histoire suit Peter peu après la mort de son **oncle bien-aimé, Ben**.

**L'étonnant Spider-Man** continue de tisser une toile dédiée aux **passionnés** dans le monde entier. Six décennies plus tard, il a été la vedette de plus de **900** bandes dessinées AMAZING SPIDER-MAN, ainsi que de longs métrages, d'annuaires, de collections, de bandes dessinées, de films, de jeux, de pièces de théâtre, de séries télévisées, etc.

● **Peter Parker**: La extraña mezcla de un adolescente desgarbado y adorablemente torpe con un superhéroe de barrio apareció por primera vez en el ejemplar de agosto de 1962 de **AMAZING FANTASY**, el n.º 15. El personaje se ganó el corazón de los fans de Marvel y no tardaría en aparecer en su primer cómic independiente, el n.º 1 de **THE AMAZING SPIDER-MAN (1963)**. Escrita por la **leyenda del cómic Stan Lee** e ilustrada por **Steve Ditko** y **Sol Brodsky**, la historia sigue a Peter poco después de la muerte de su querido **tío Ben**.

**The Amazing Spider-Man** sigue tejiendo una red de **fans entregados** por todo el mundo. Seis décadas después, ha protagonizado más de **900** cómics de THE AMAZING SPIDER-MAN, además de largometrajes, anuarios, colecciones, tiras de periódicos, películas, juegos, obras de teatro, series para televisión y muchas cosas más.





Iconic covers through the years  
Des couvertures emblématiques au fil des ans  
Portadas icónicas a lo largo de los años

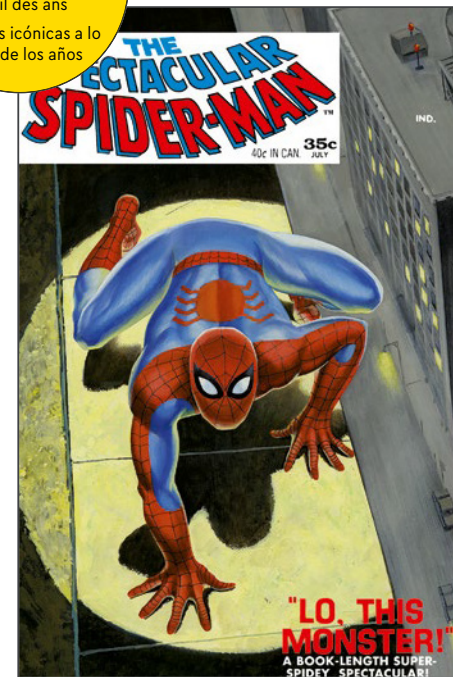
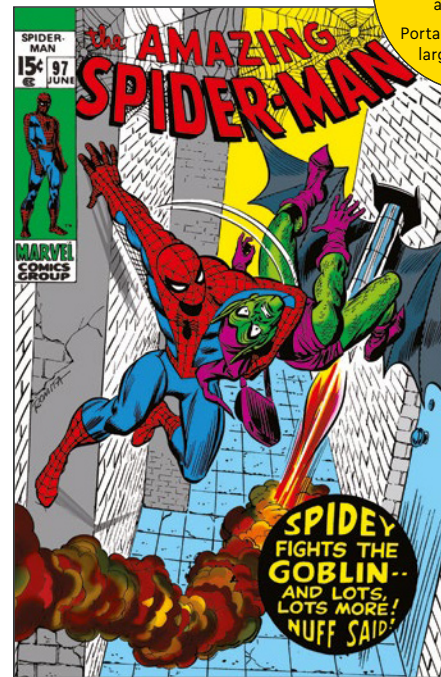



## BUILD & DISPLAY – EDITOR'S NOTES:

● **AND NOW...** Before you begin, make sure you find a space **big** enough for the frame – and **sort** your LEGO® bricks. The **step-by-step guide** takes you through a **unique building experience** as you watch your Spider-Man comic panel **come to life!**



## CONSTRUIRE ET EXPOSER – NOTES DE L'ÉDITEUR :

● **ET MAINTENANT...** Avant de commencer, assurez-vous de trouver un espace suffisamment grand pour le cadre, puis triez vos briques LEGO®. Le **guide étape par étape** vous fait vivre une **expérience de construction unique** à mesure que vous regardez votre bande dessinée Spider-Man **prendre vie !**





## PARA CONSTRUIR Y EXHIBIR: NOTAS DEL EDITOR

● **Y AHORA...** Antes de empezar, asegúrate de encontrar un espacio lo suficientemente **grande** para el marco y **clasifica** tus bricks LEGO®. La **guía paso a paso** te lleva a través de una **experiencia de construcción única** mientras ves cómo **cobra vida** tu panel de cómic de Spider-Man.



 **SOUNDTRACK**  
Only in English  
**BANDE SONORE**  
En anglais uniquement  
**BANDA SONORA**  
Solo en inglés



## IMPORTANT BULLETIN!

● **Don't miss** the guided tour **behind the scenes** of your LEGO® Art Spider-Man set! Scan the QR code to play the **Soundtrack**, with designer interviews and anecdotes from the history of **Spider-Man comic books**.

## DO YOU FEEL THAT?

Could it be your **Spidey-builder sense** tingling? You might notice we've used loads of **advanced math** to create a fun building experience – and that's just how Peter Parker would like it.

## HAVE A GAS!

Reconnect with your inner **super hero** and spin yourself an Amazing Fantasy web of **creative art**.

## BULLETIN IMPORTANT !

● **Ne manquez pas** la visite guidée **dans les coulisses** de votre ensemble LEGO® Art Spider-Man ! Scannez le code QR pour écouter la **bande sonore**, ainsi que les entretiens avec les dessinateurs et les anecdotes de l'histoire des **bandes dessinées Spider-Man**.

## RESSENTEZ-VOUS CELA ?

Serait-ce votre **sens d'araignée constructrice** qui picote ? Vous remarquerez peut-être que nous avons utilisé des tas de **mathématiques avancées** pour créer une expérience de construction amusante – et c'est exactement comme cela que Peter Parker l'aimerait.

## ÉCLATEZ-VOUS !

Reprenez contact avec le **superhéros** qui sommeille en vous et tissez une toile **d'art créatif** incroyablement fantastique.

## ¡BOLETÍN IMPORTANTE!

● **¡No te pierdas** la visita guiada **tras bambalinas** de tu set LEGO® Art Spider-Man! Escanea el código QR para reproducir la **banda sonora** con entrevistas a los diseñadores y anécdotas de la historia de los **cómics de Spider-Man**.

## ¿SENTISTE ESO?

¿Será acaso tu **sentido arácnido de constructor**? Quizá hayas notado de que utilizamos montones de **matemáticas avanzadas** para crear una experiencia de construcción divertida, ¡tal como le gustaría a Peter Parker!

## ¡DISFRUTA COMO NUNCA!

Vuelve a conectar con el **superhéroe** que llevas dentro e hila tú mismo una telaraña de asombroso **arte creativo** de fantasía.

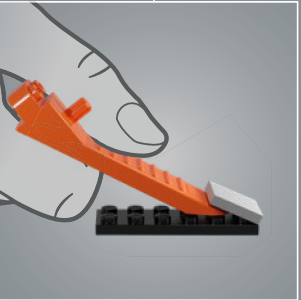
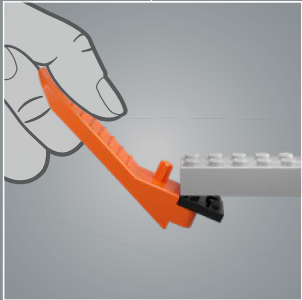
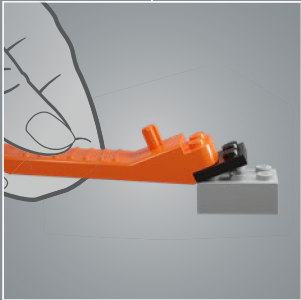
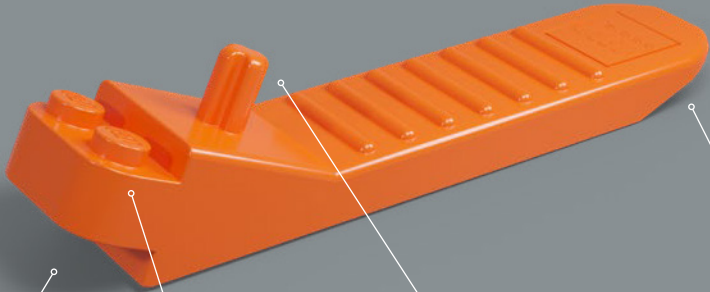

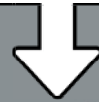
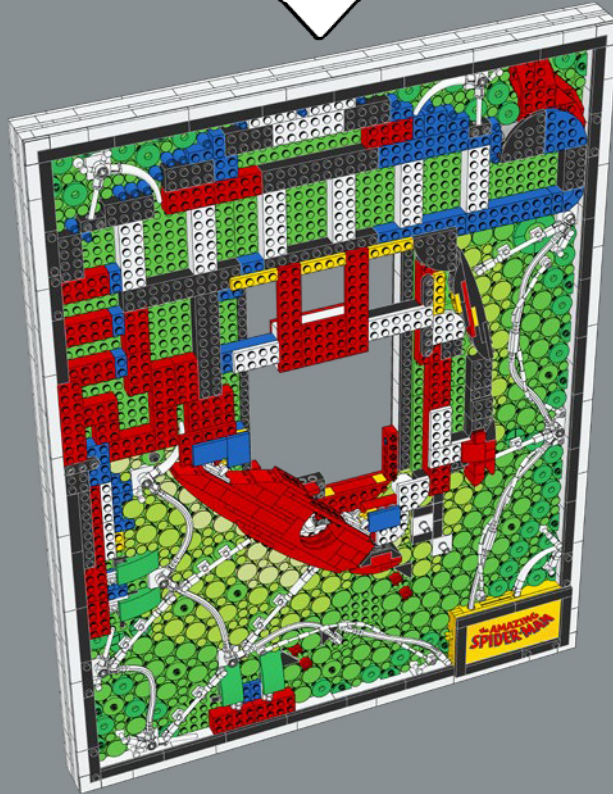
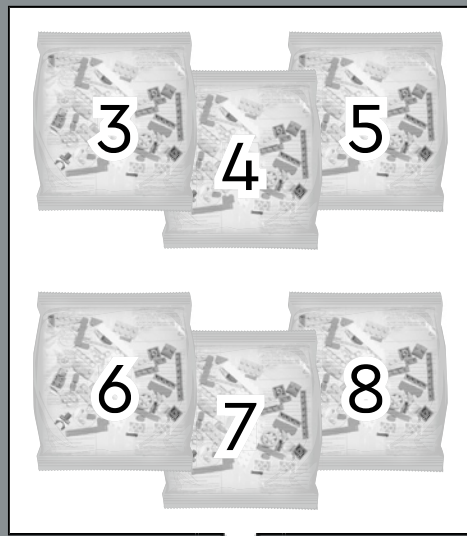
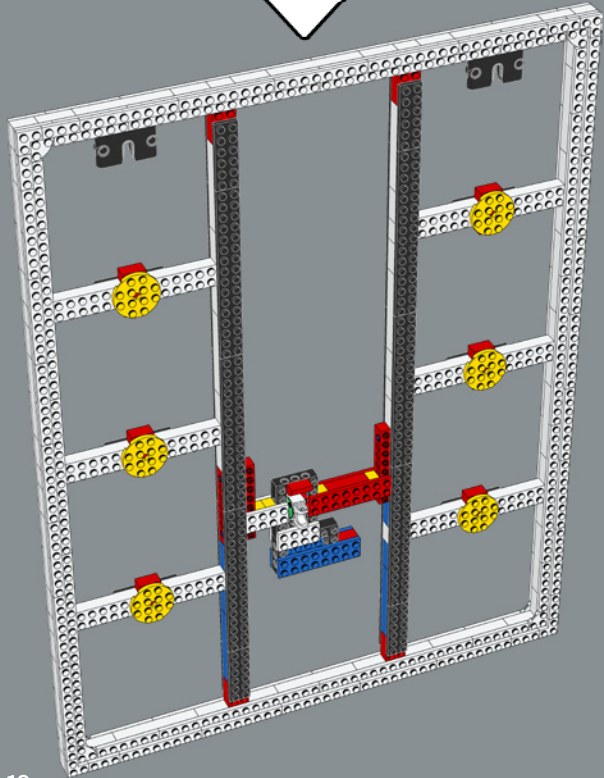
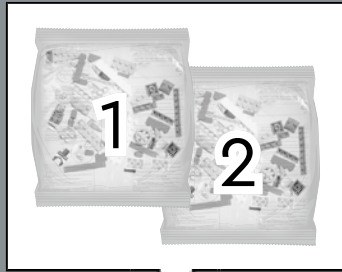

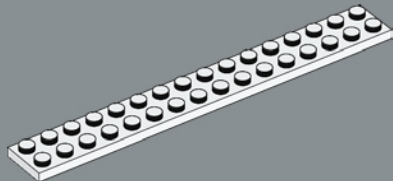
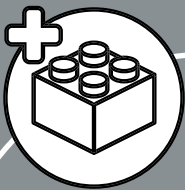

10x

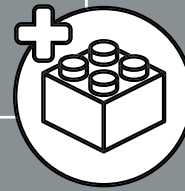
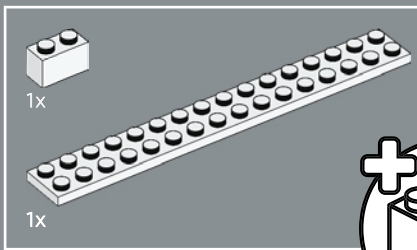

1

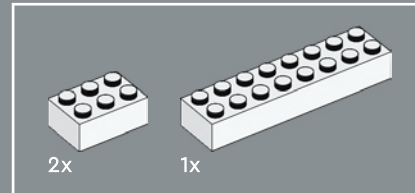
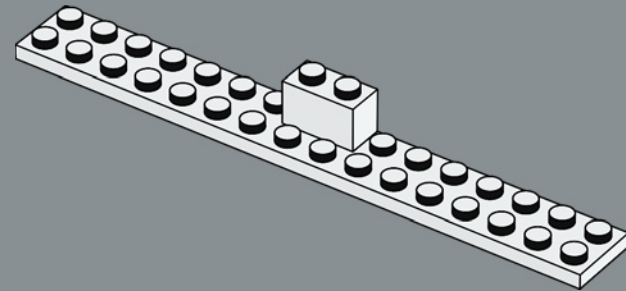

2

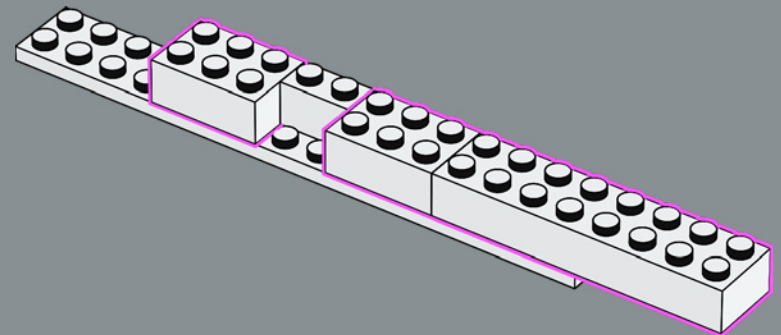

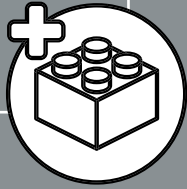
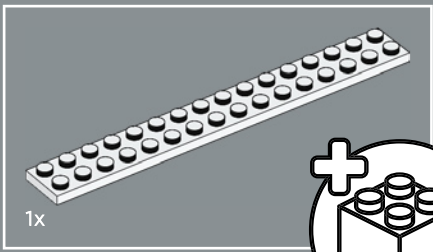

3

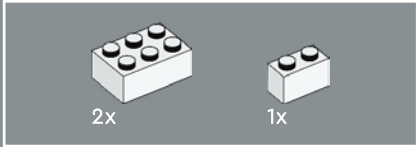
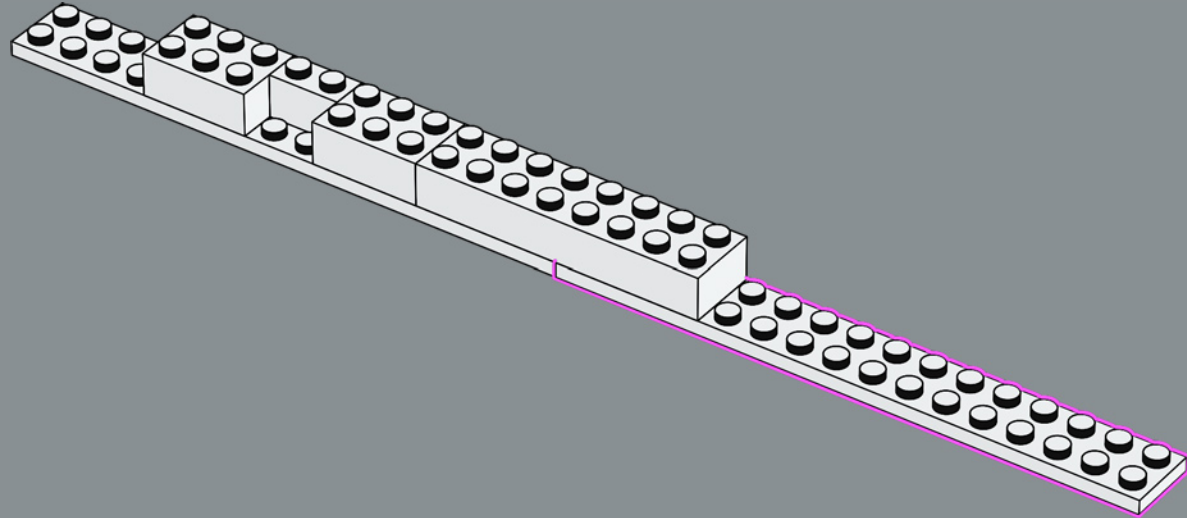

4

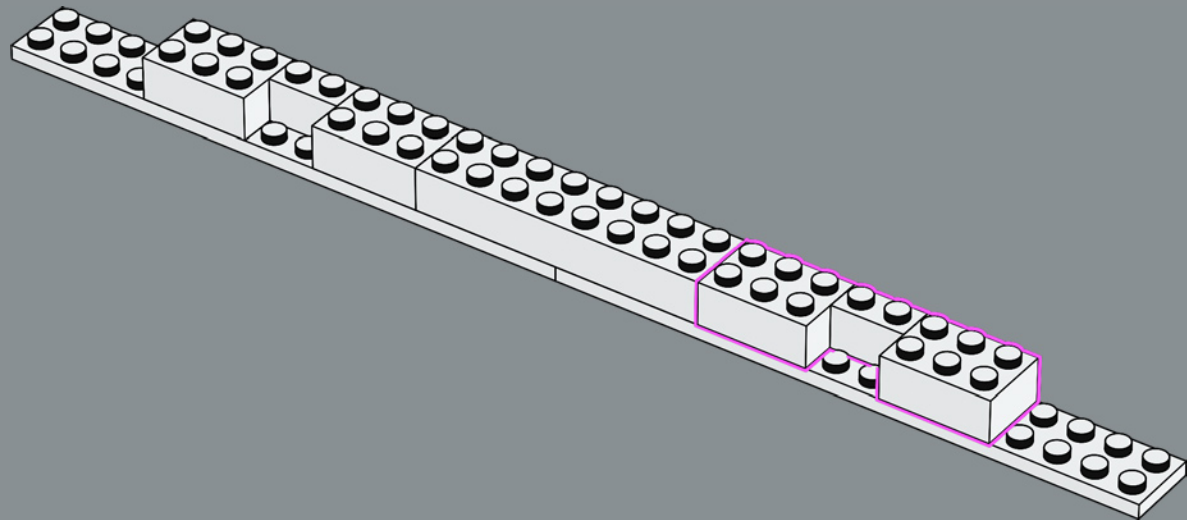

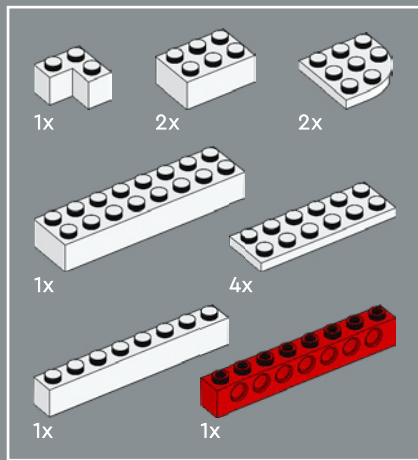

5

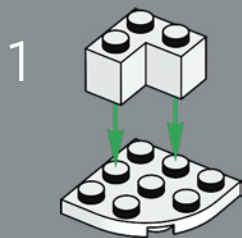

2

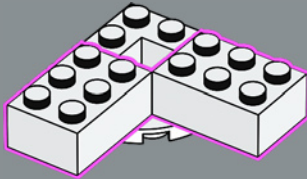

3

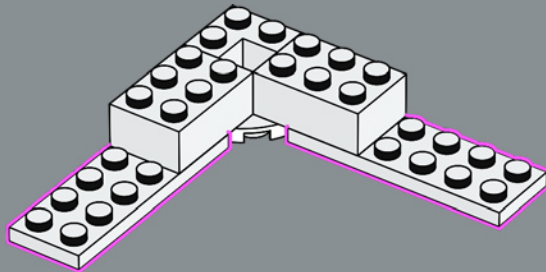

4

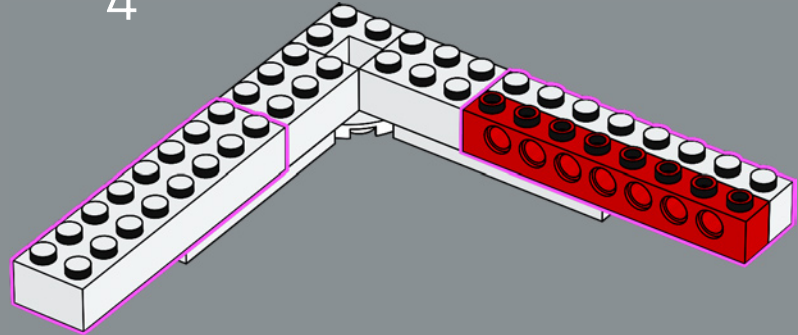

5

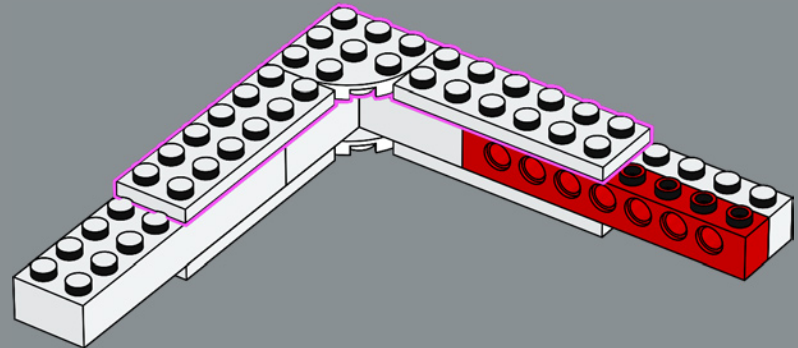

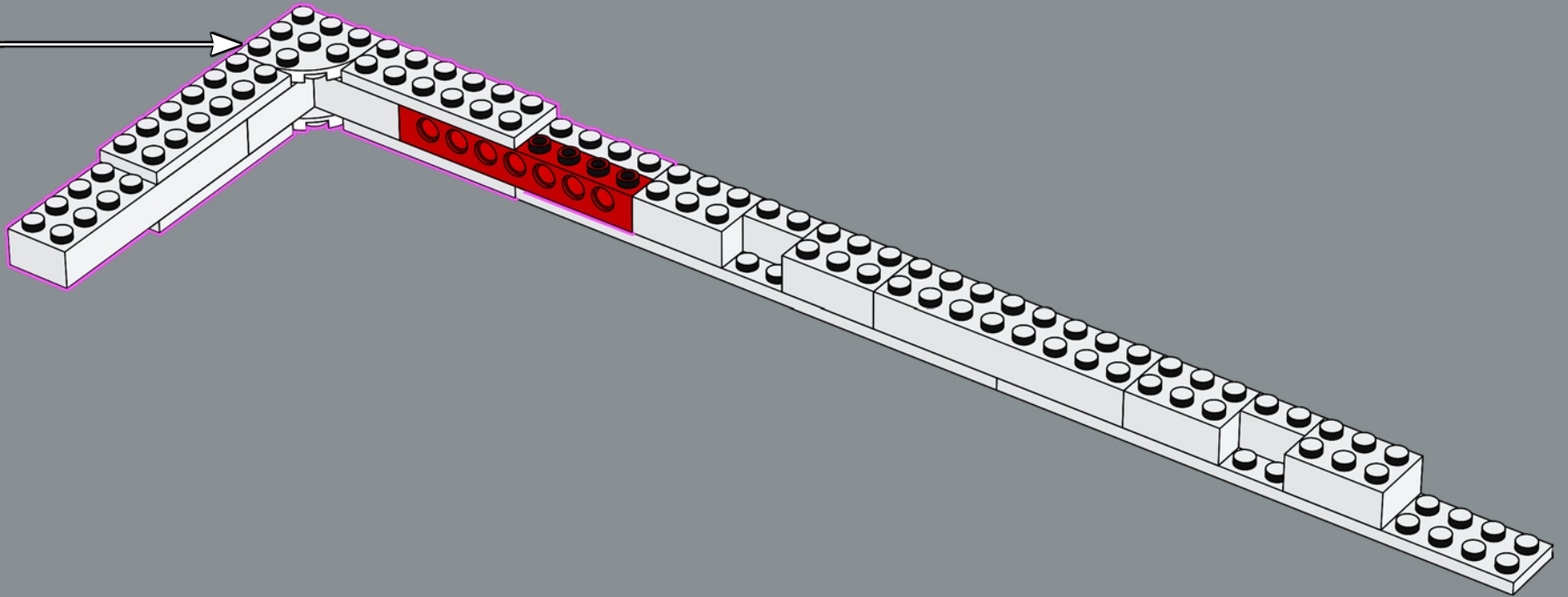



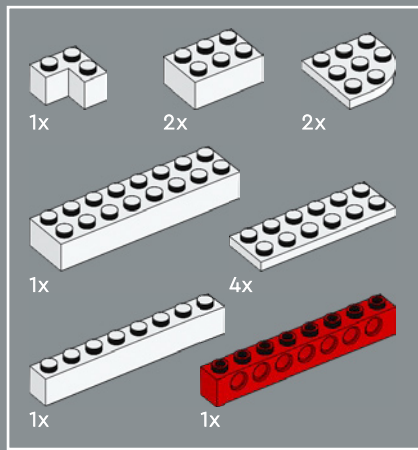

6

1

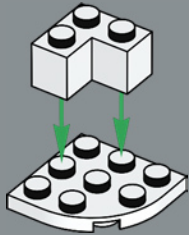

2

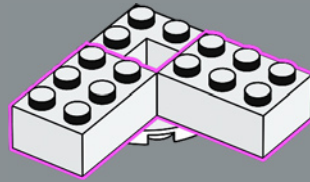

3

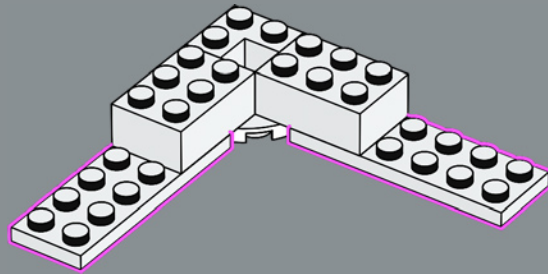

4

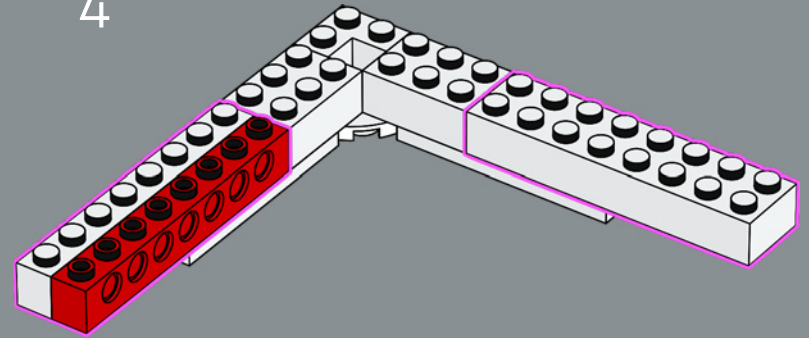

5

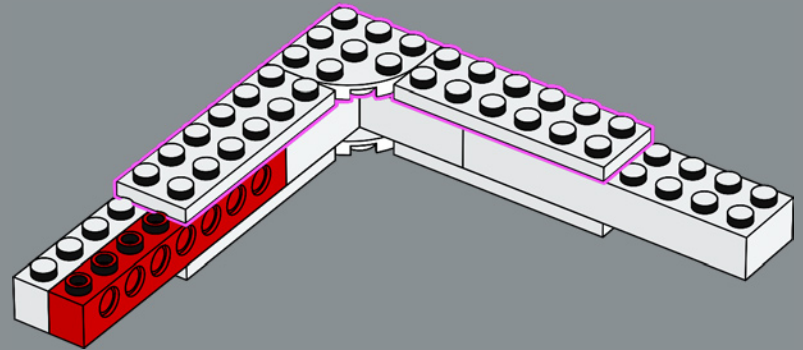

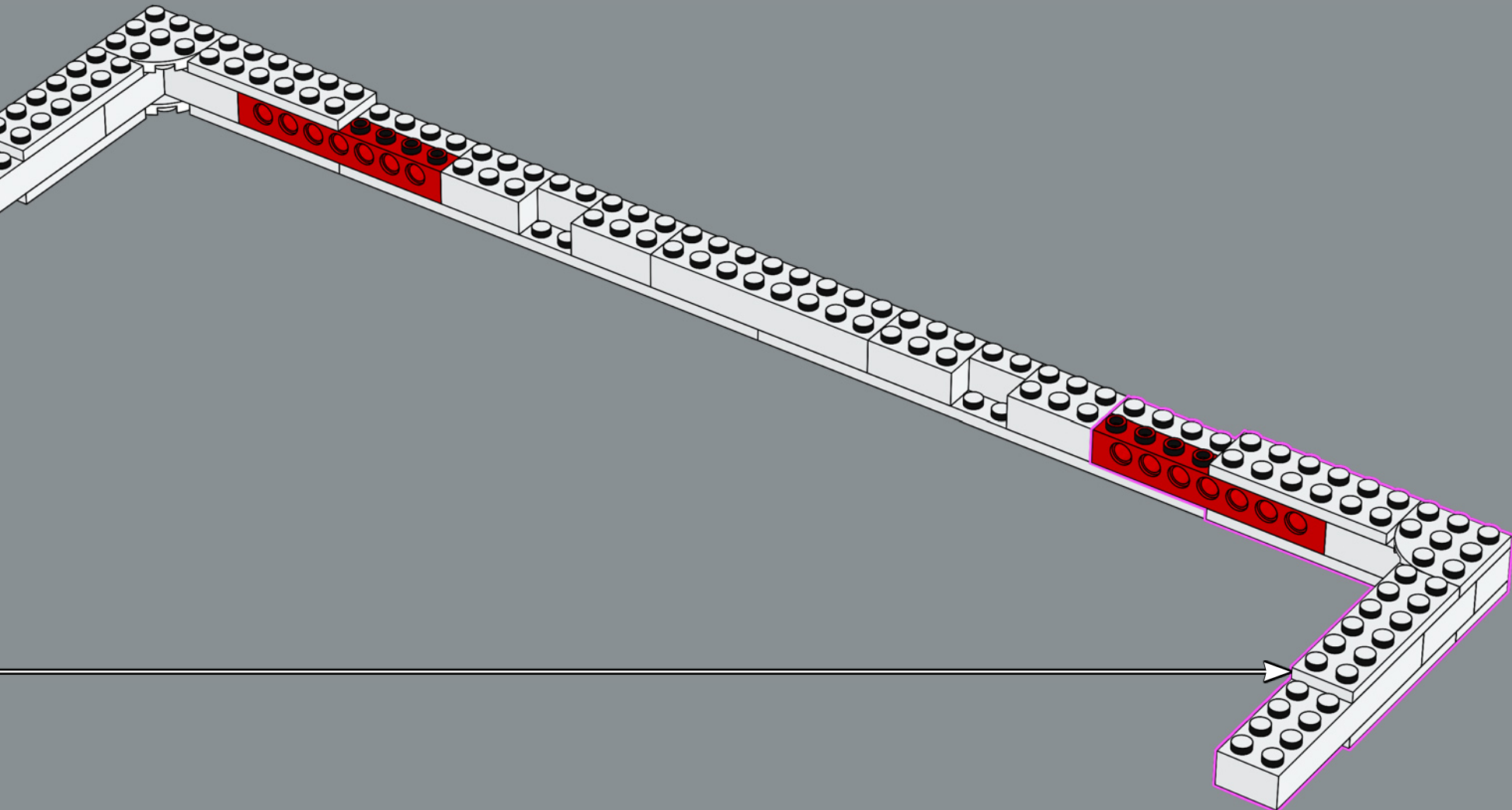

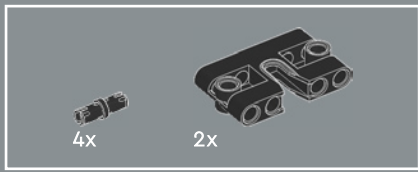

7

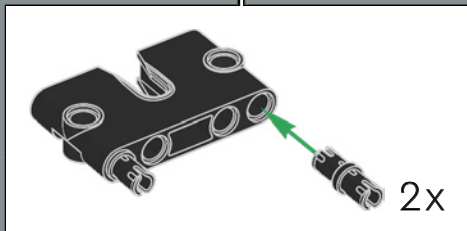
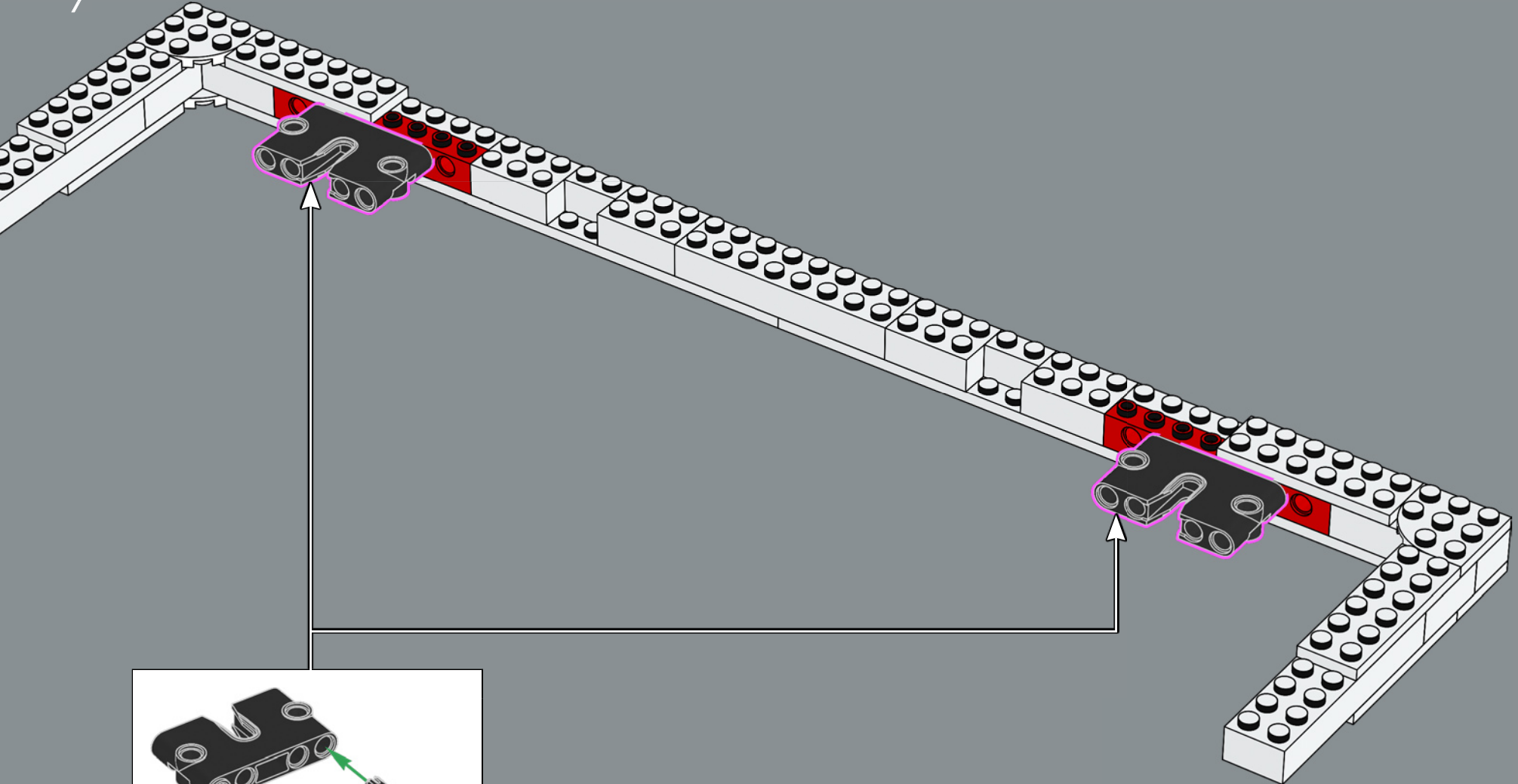

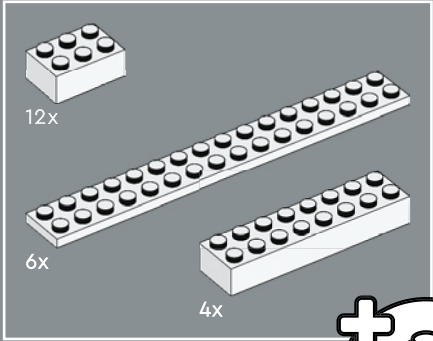
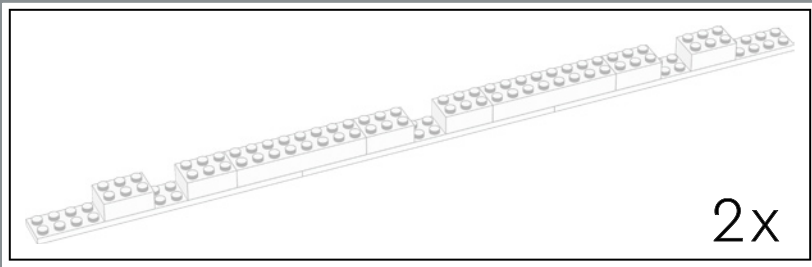

8

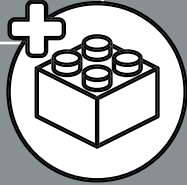

1

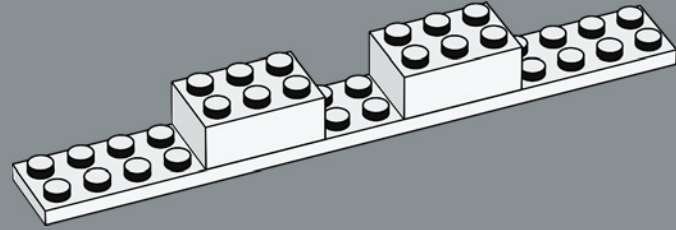

2

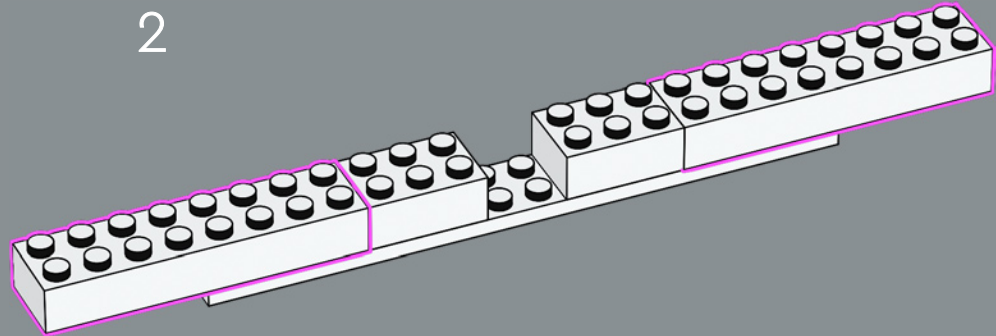

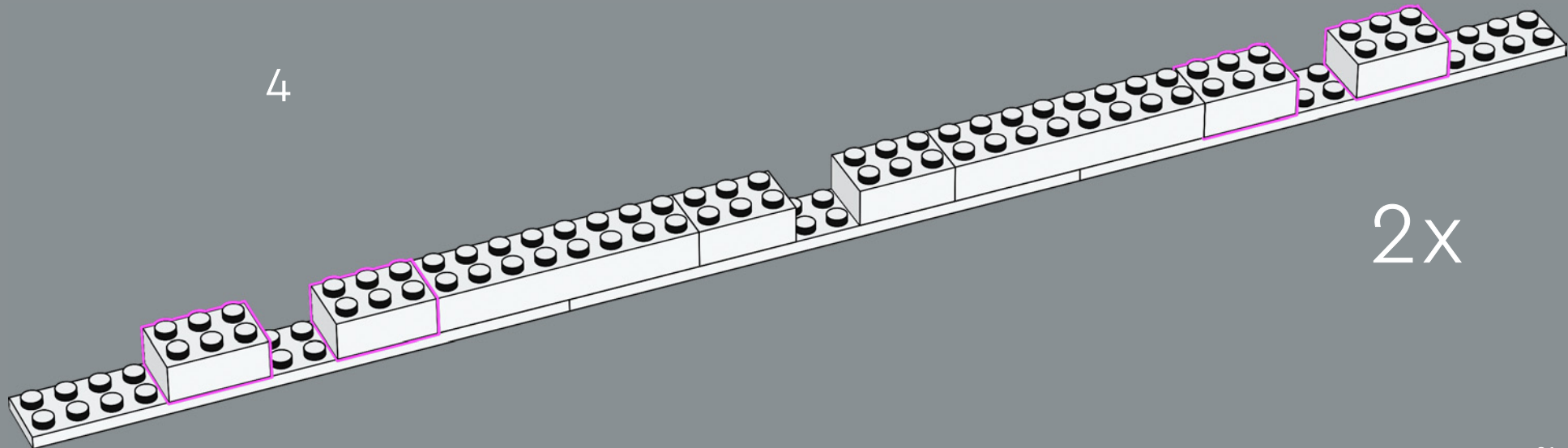
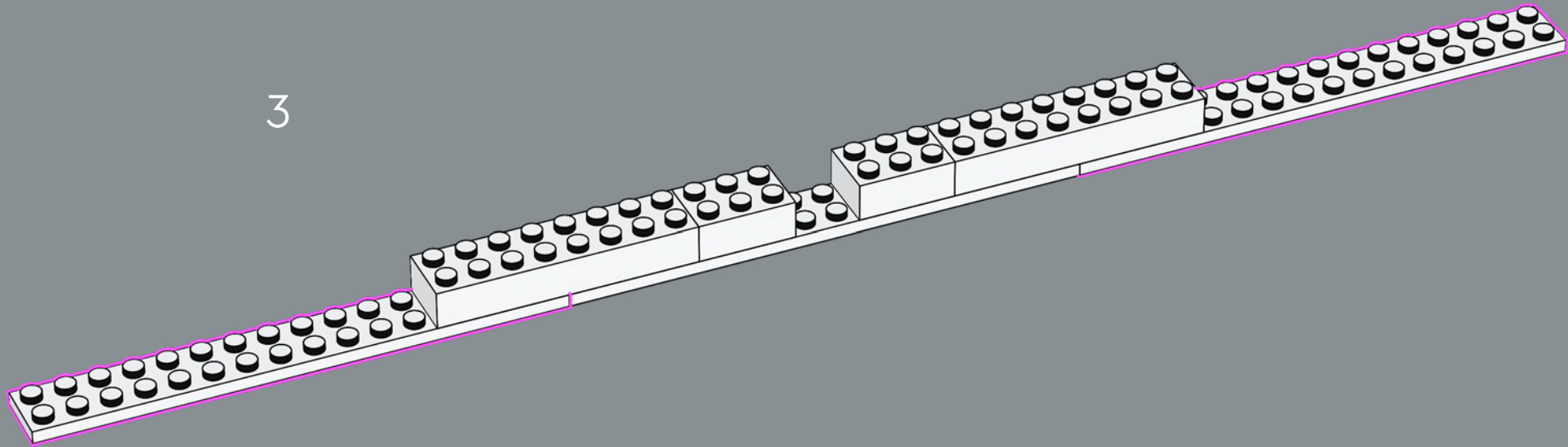

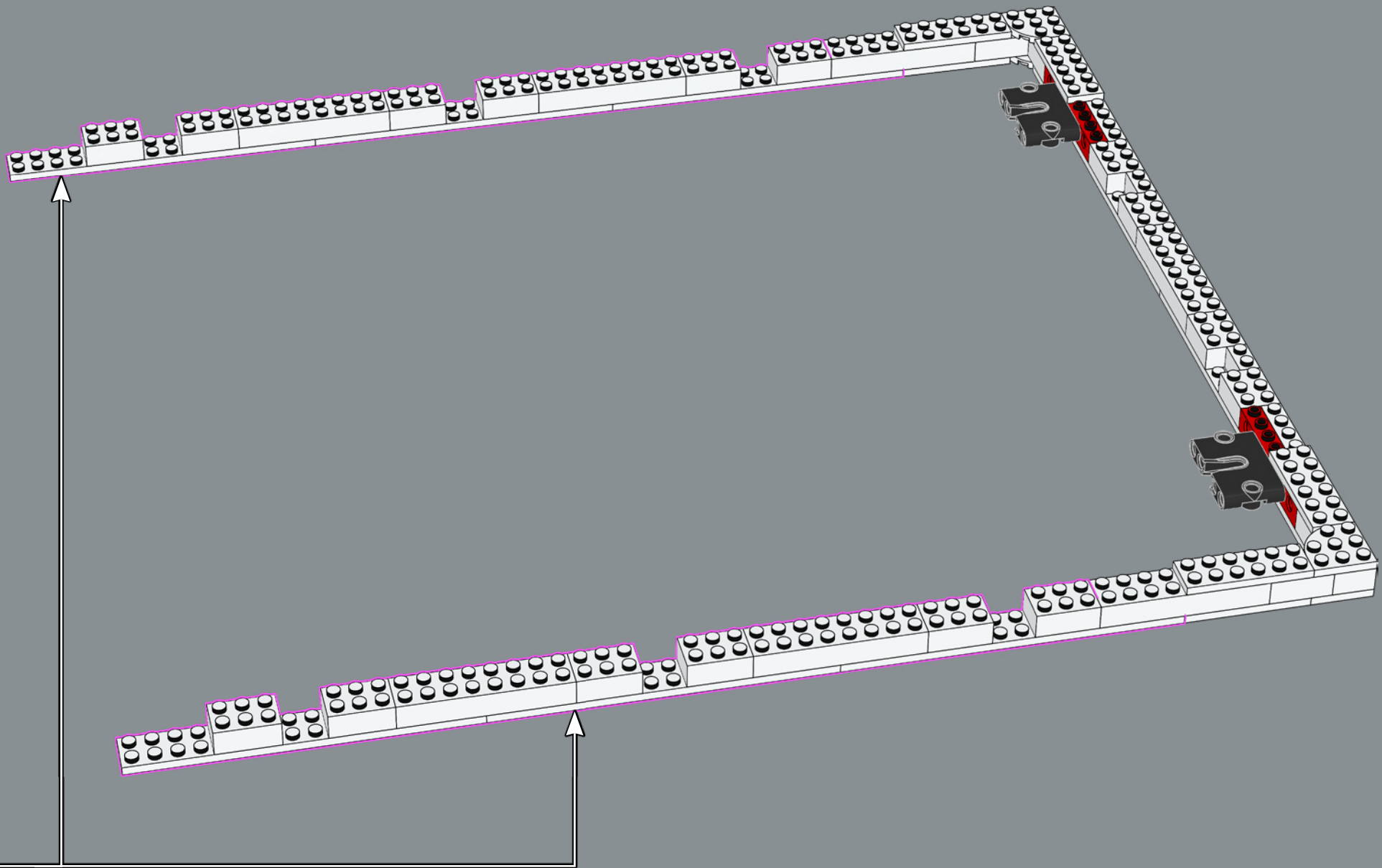

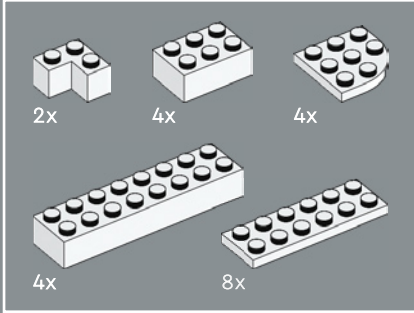
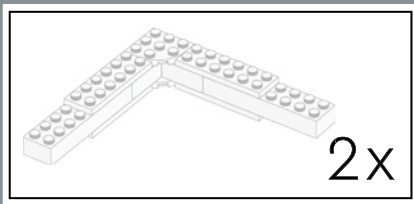

9

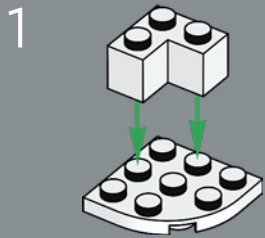

2

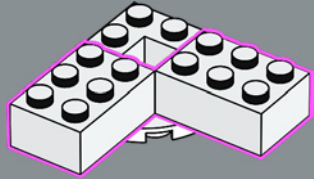

3

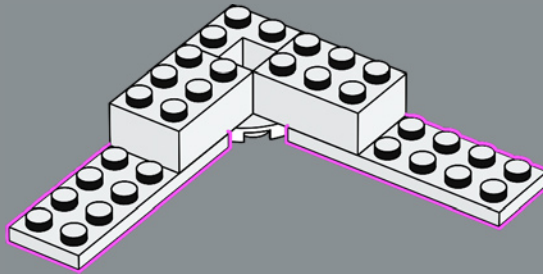

4

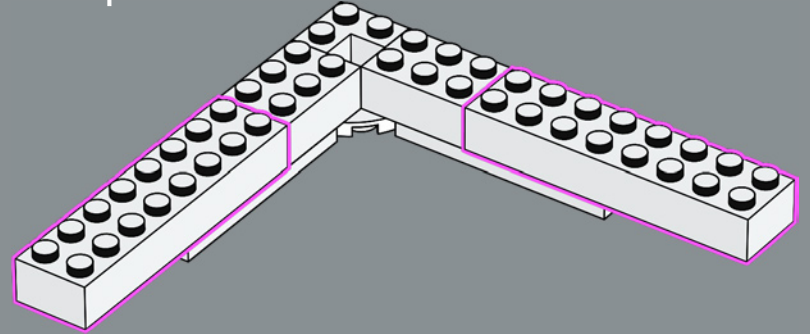

5

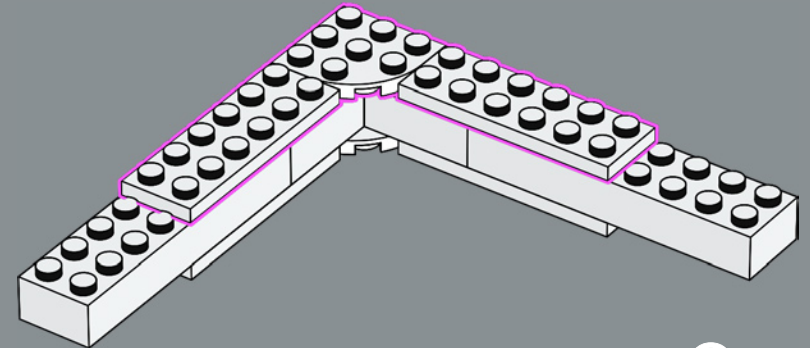

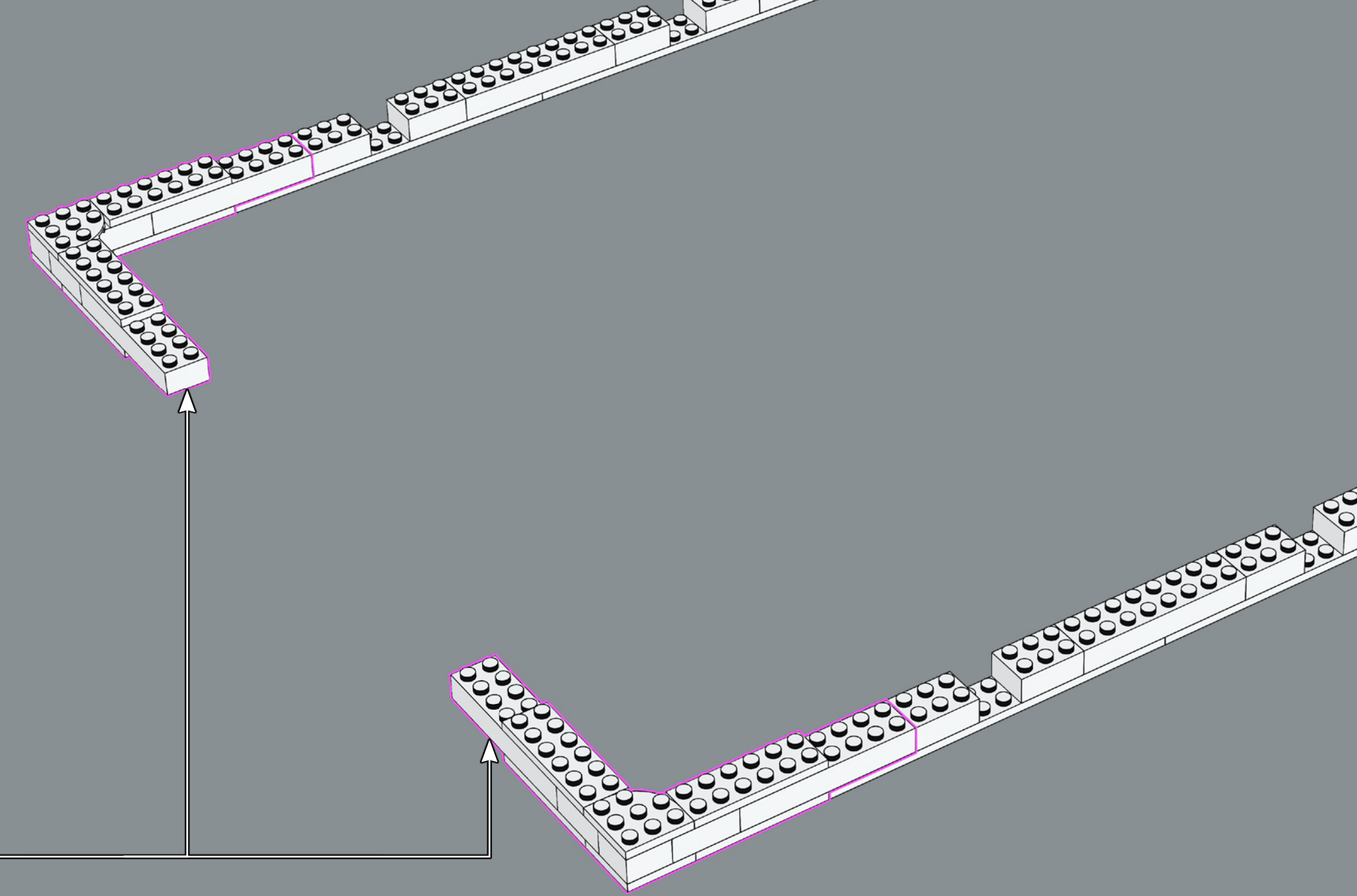



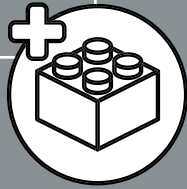
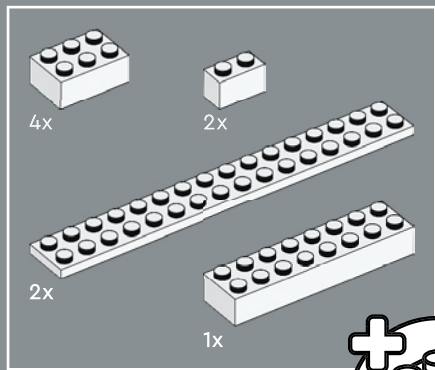

10

1

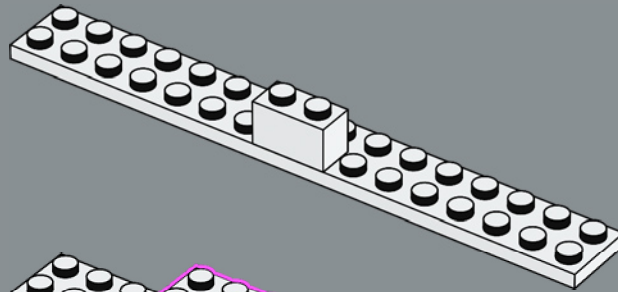

2

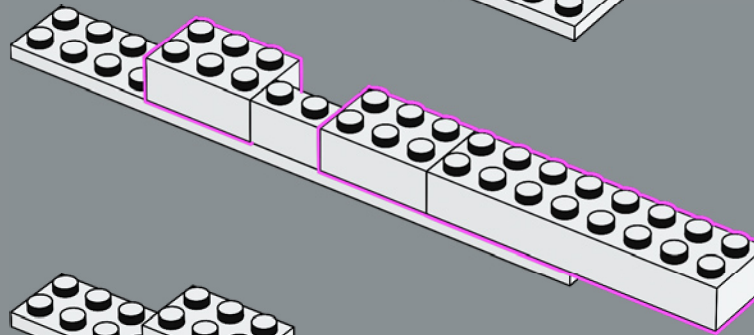

3

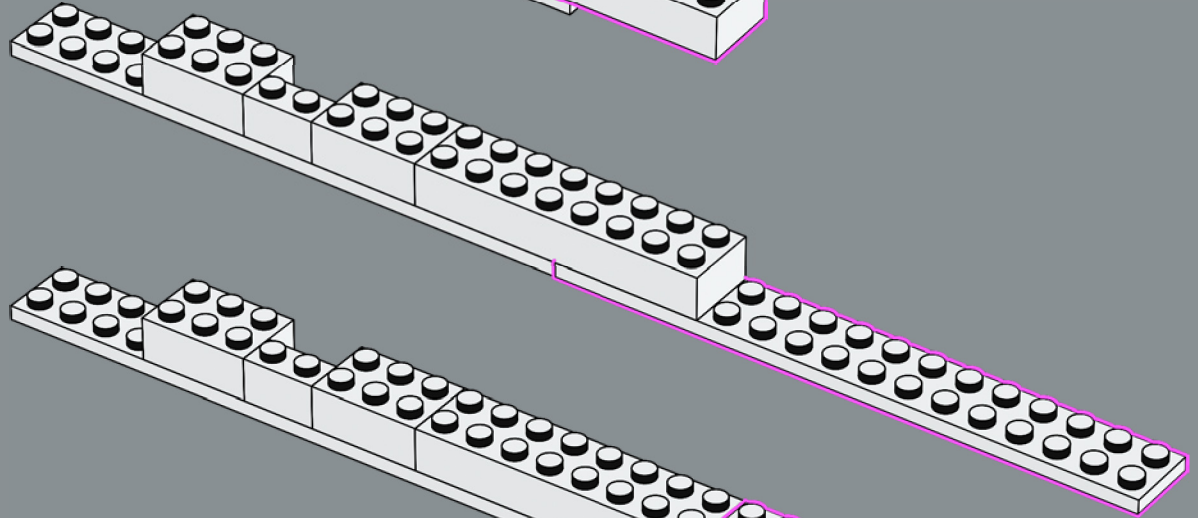

4

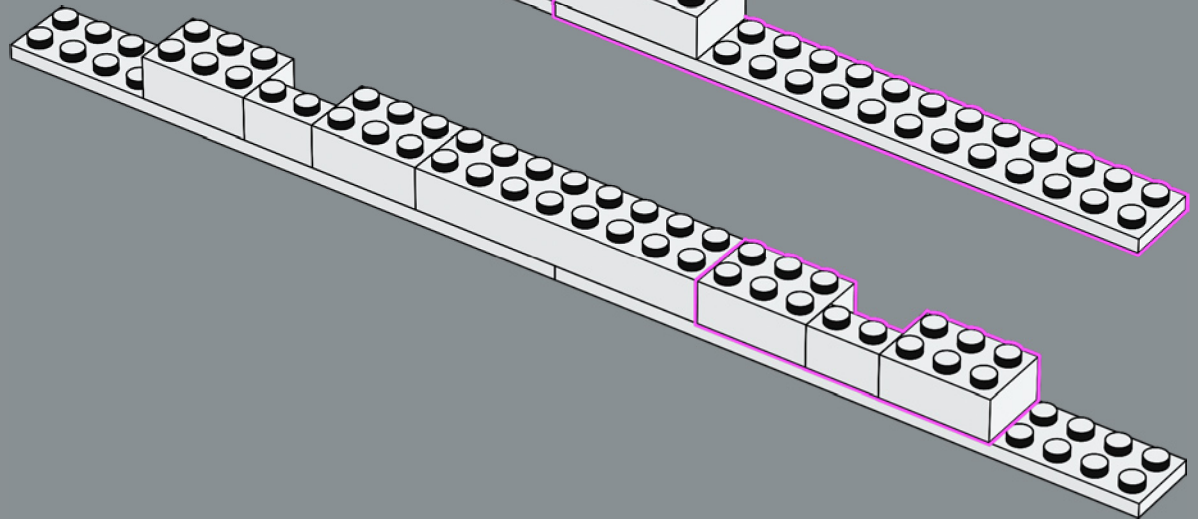

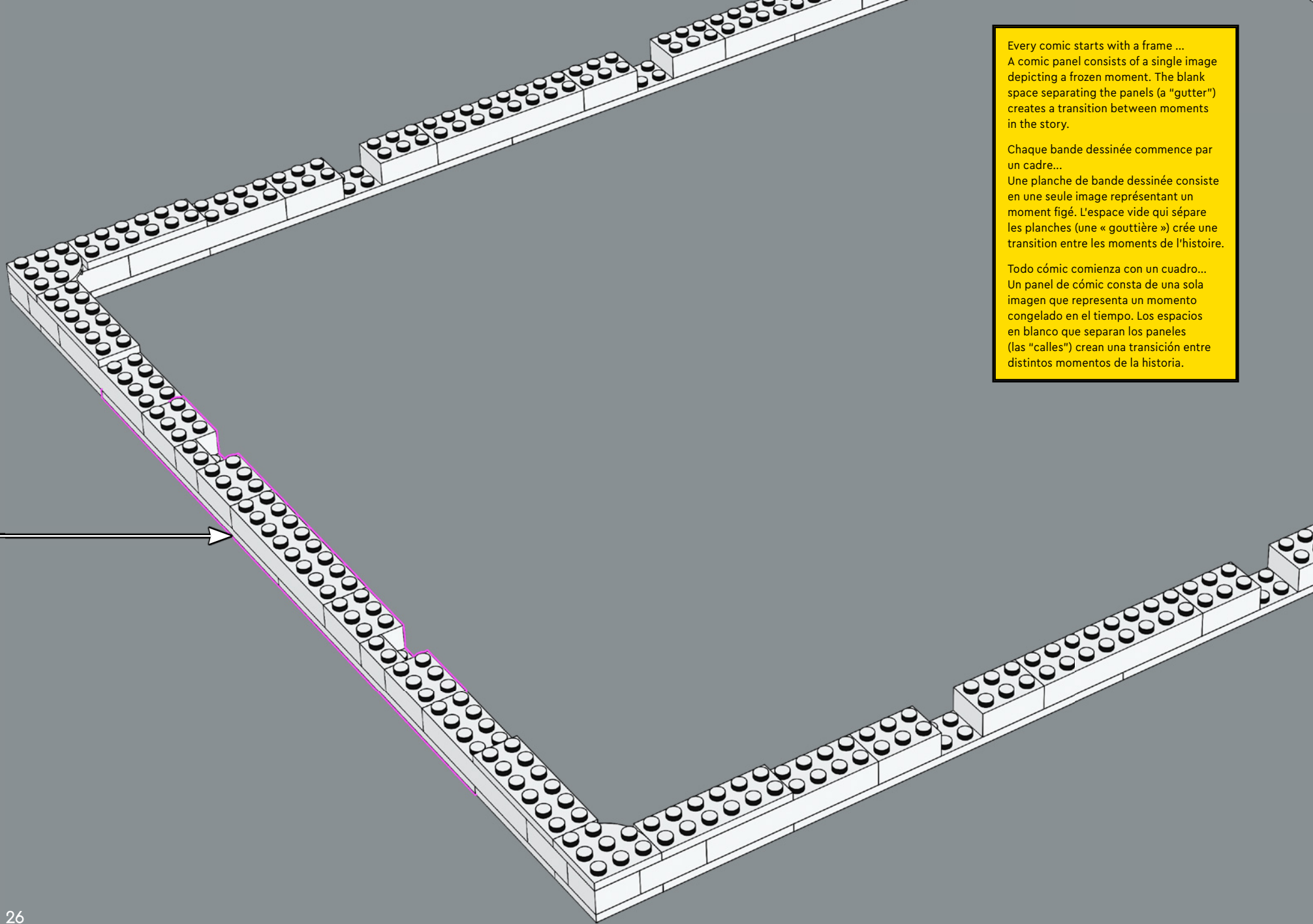

Every comic starts with a frame ...  
A comic panel consists of a single image depicting a frozen moment. The blank space separating the panels (a "gutter") creates a transition between moments in the story.

Chaque bande dessinée commence par un cadre...  
Une planche de bande dessinée consiste en une seule image représentant un moment figé. L'espace vide qui sépare les planches (une « gouttière ») crée une transition entre les moments de l'histoire.

Todo cómic comienza con un cuadro...  
Un panel de cómic consta de una sola imagen que representa un momento congelado en el tiempo. Los espacios en blanco que separan los paneles (las "calles") crean una transición entre distintos momentos de la historia.

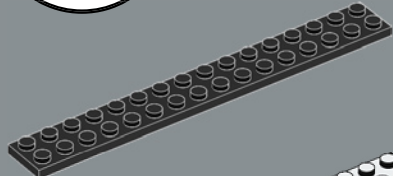
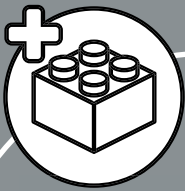

12x

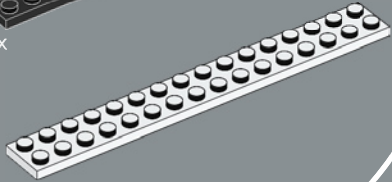

10x

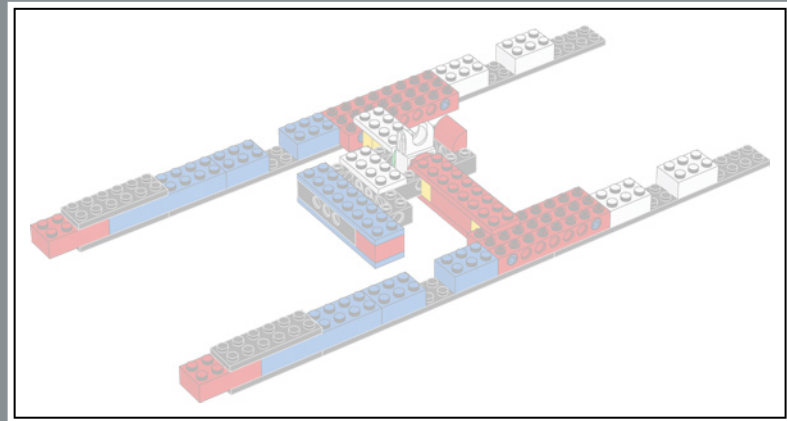

1x



1x

11

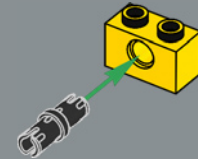

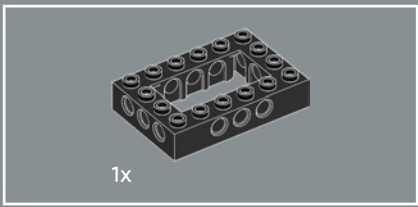

12

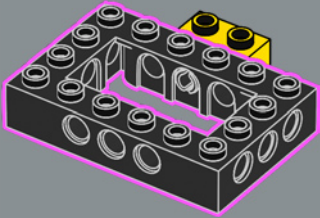

13

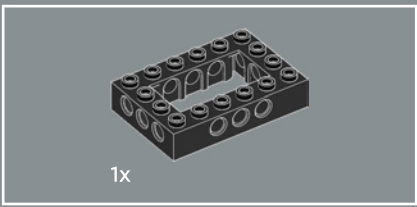
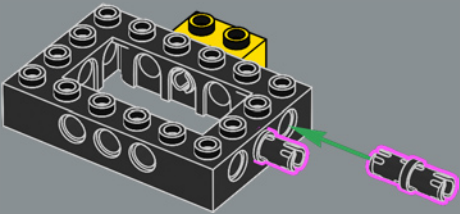

14

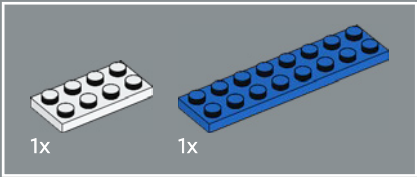
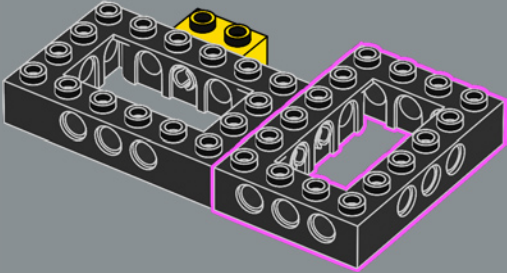

15

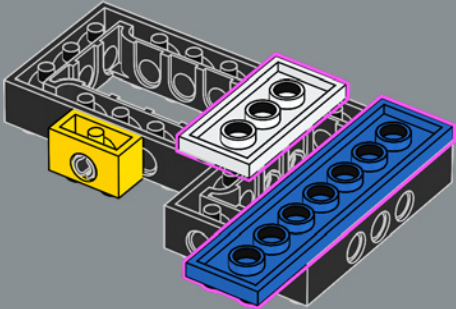

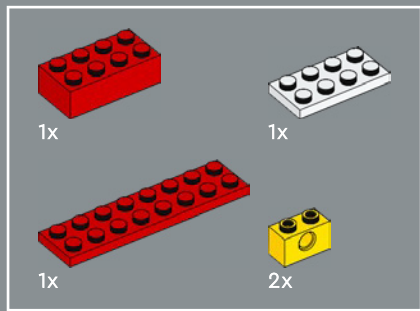

16

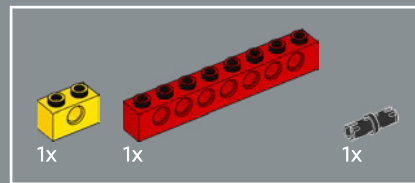
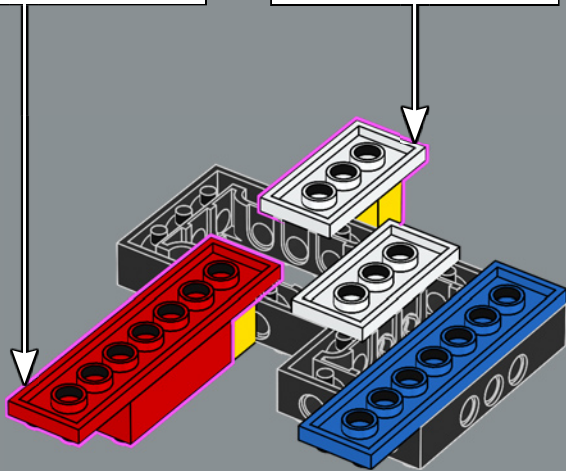
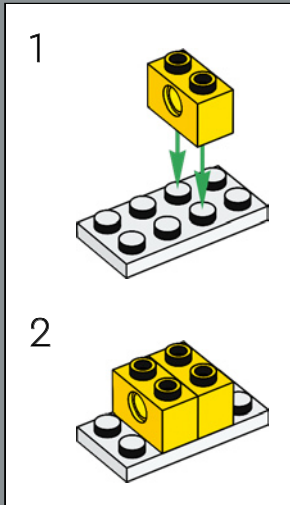
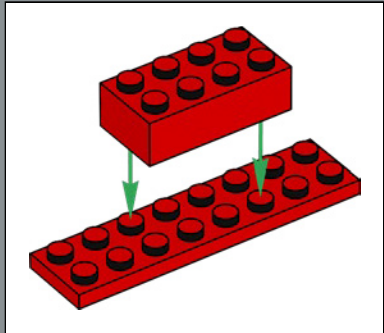

17

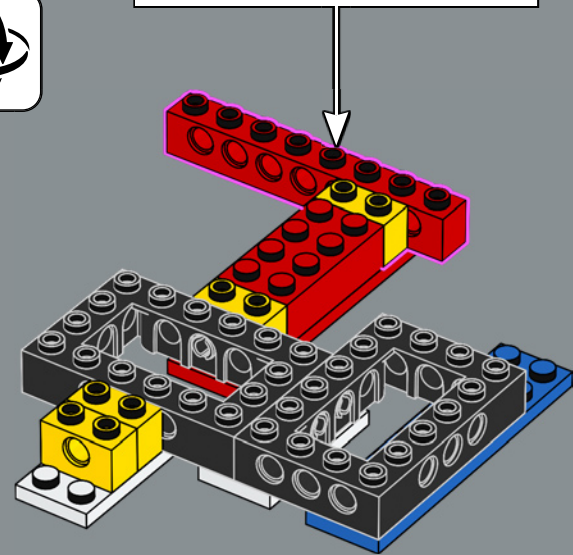
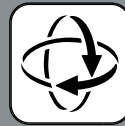
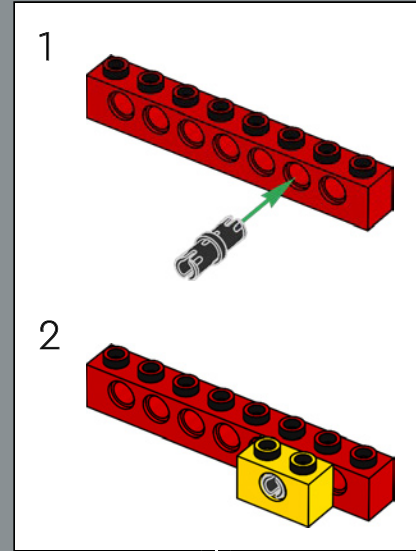

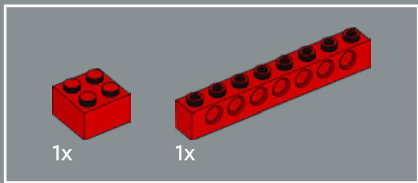

18

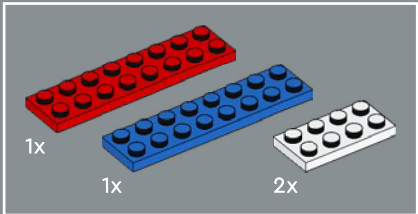
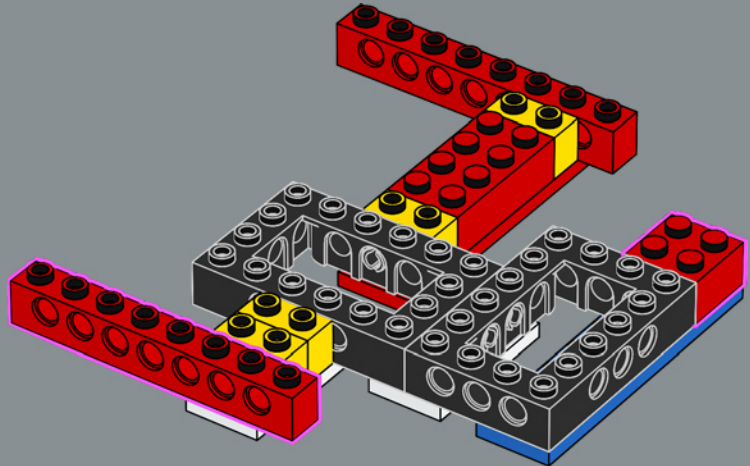

19

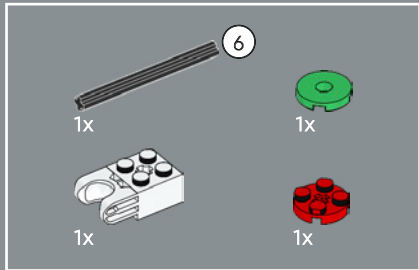
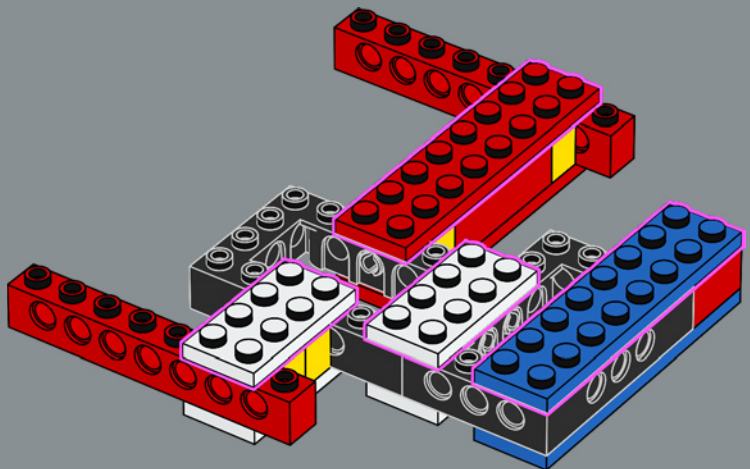

20

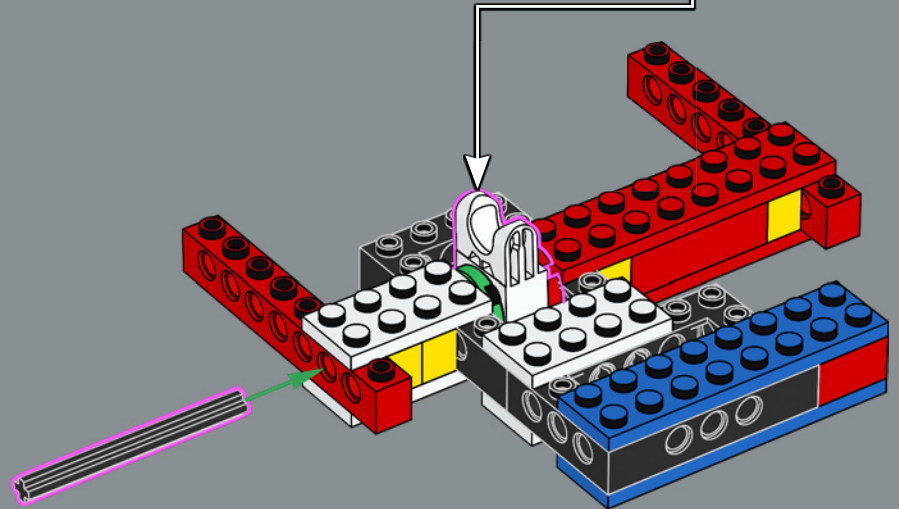
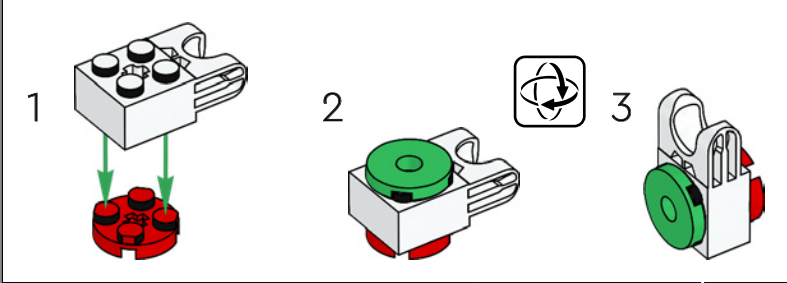

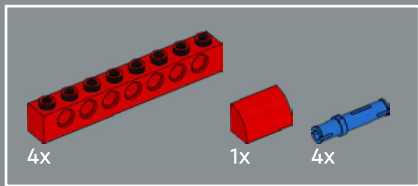

21

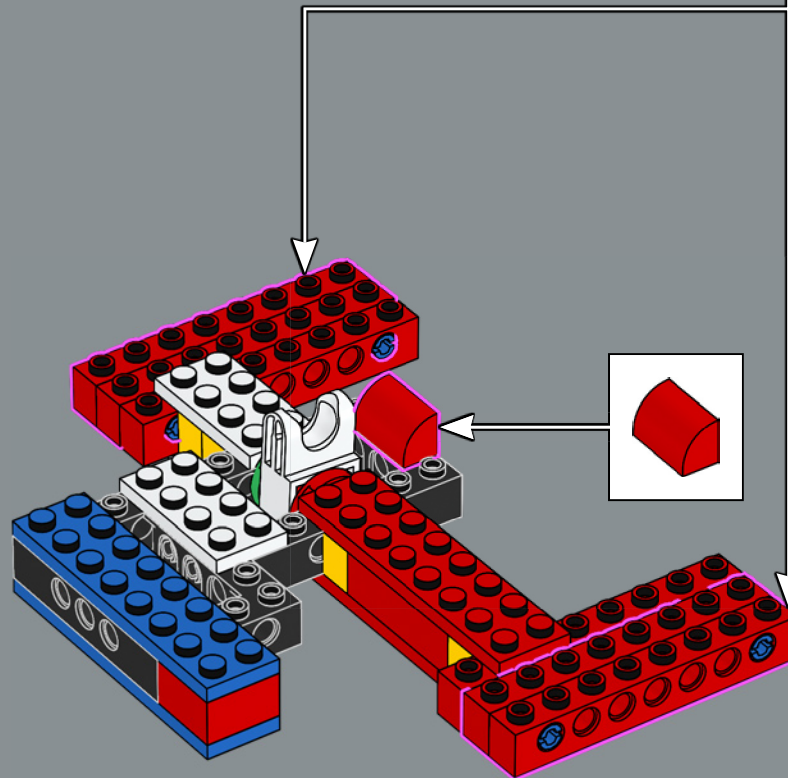
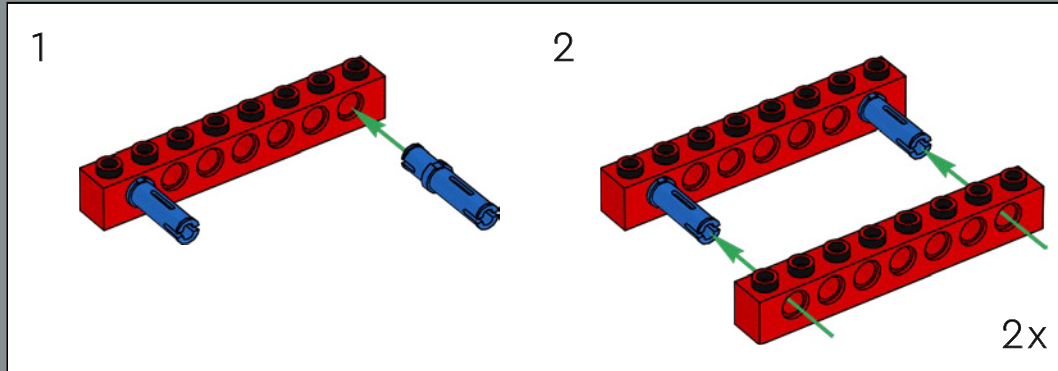

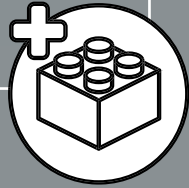
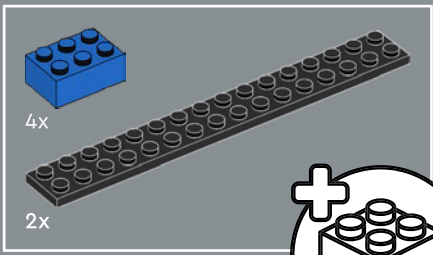

22

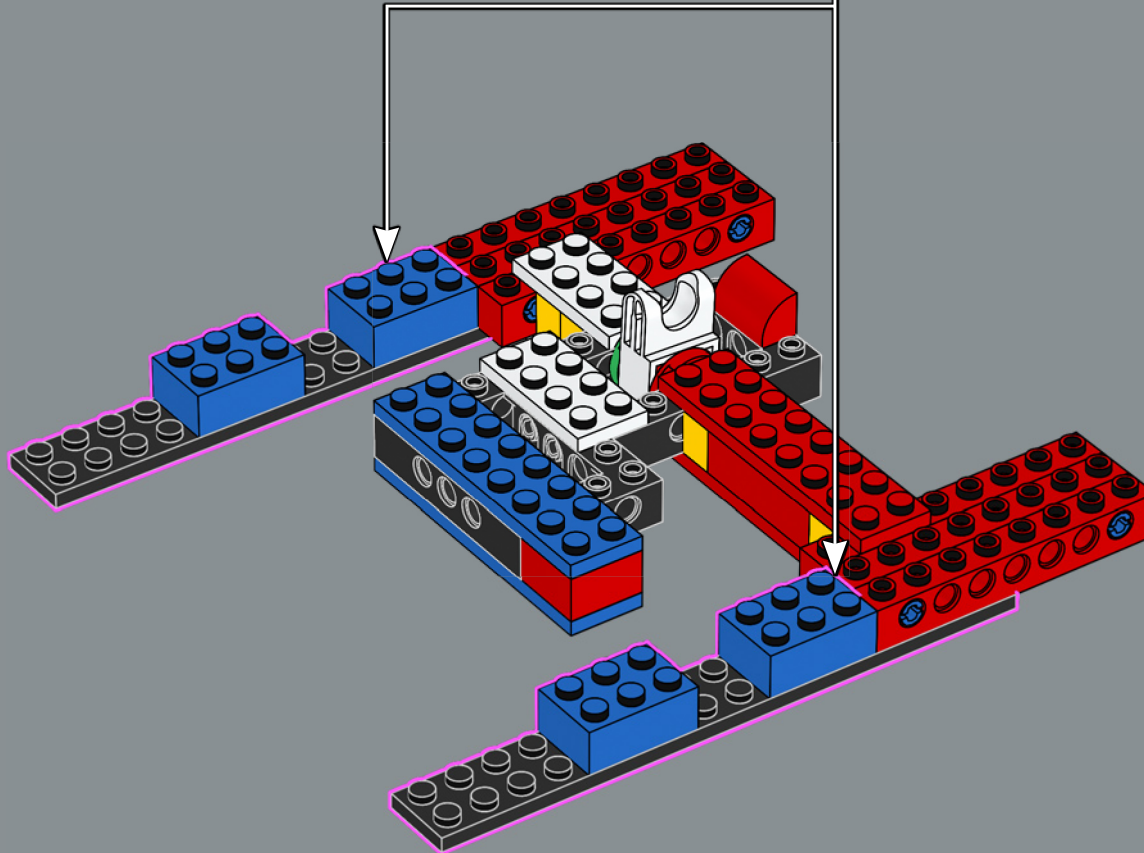
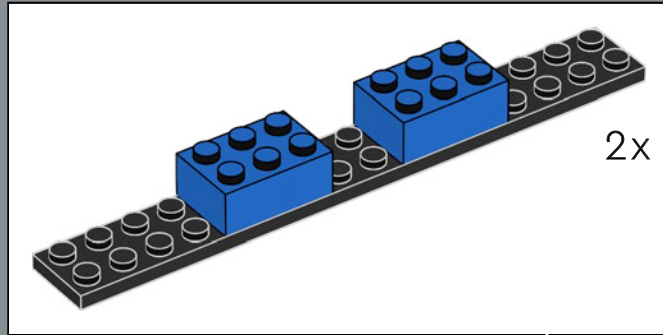



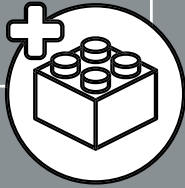
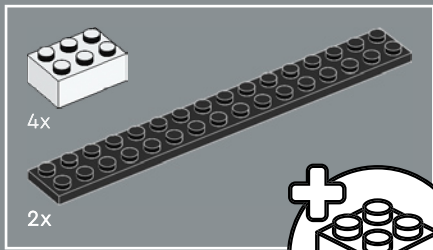

23

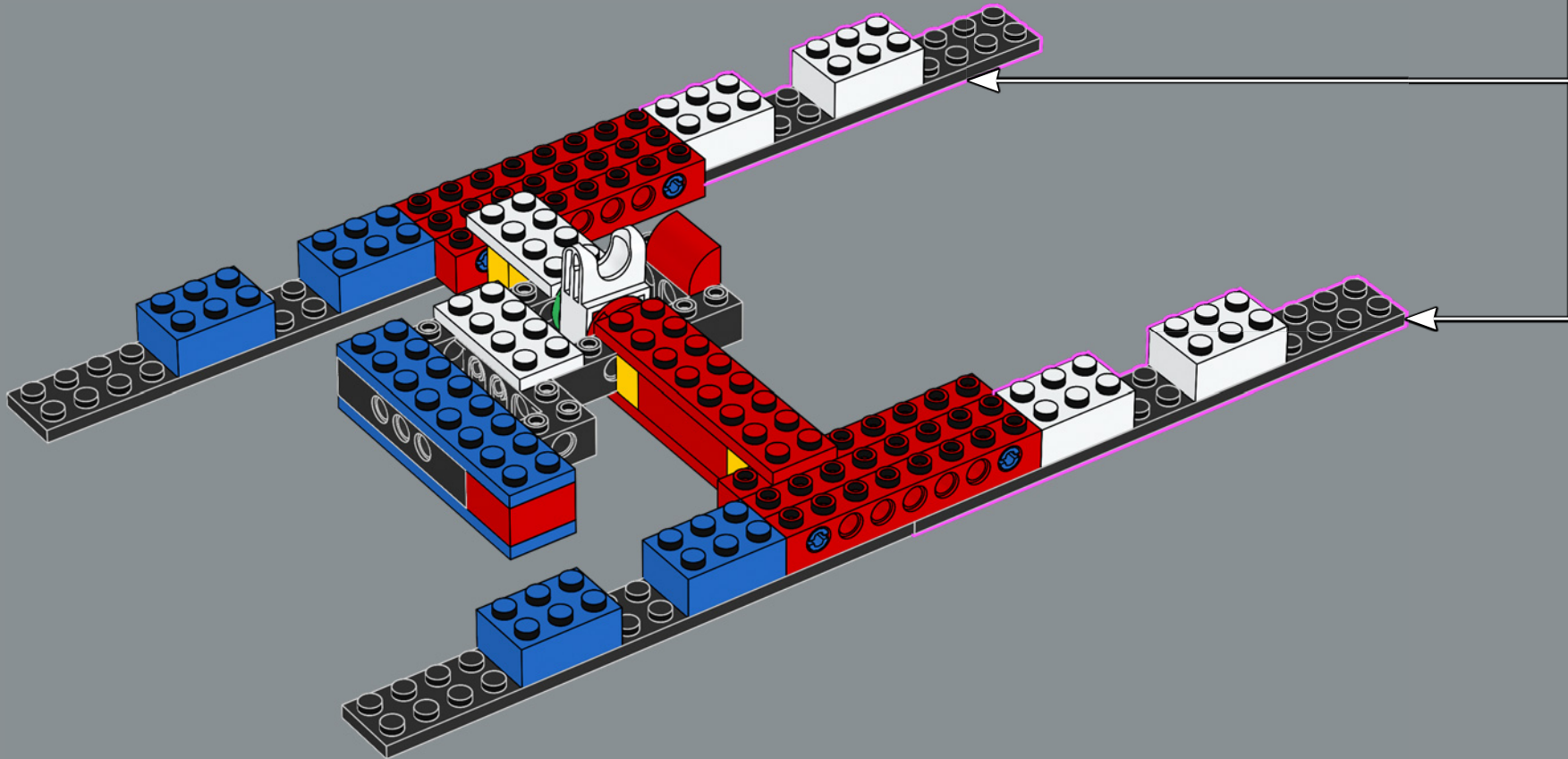
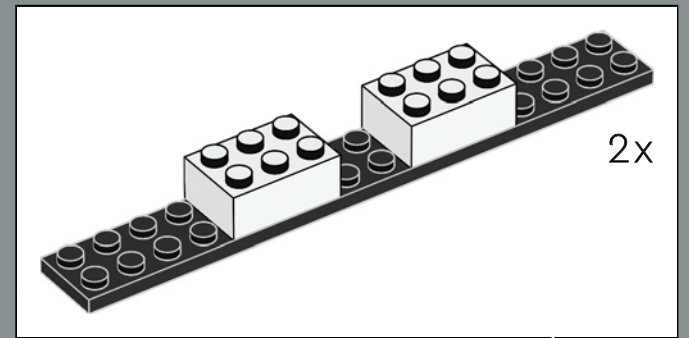

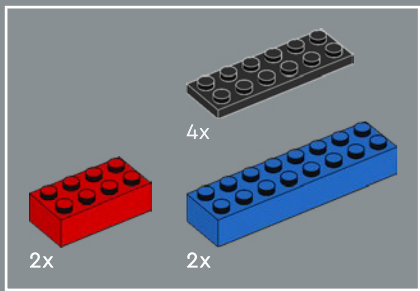

24

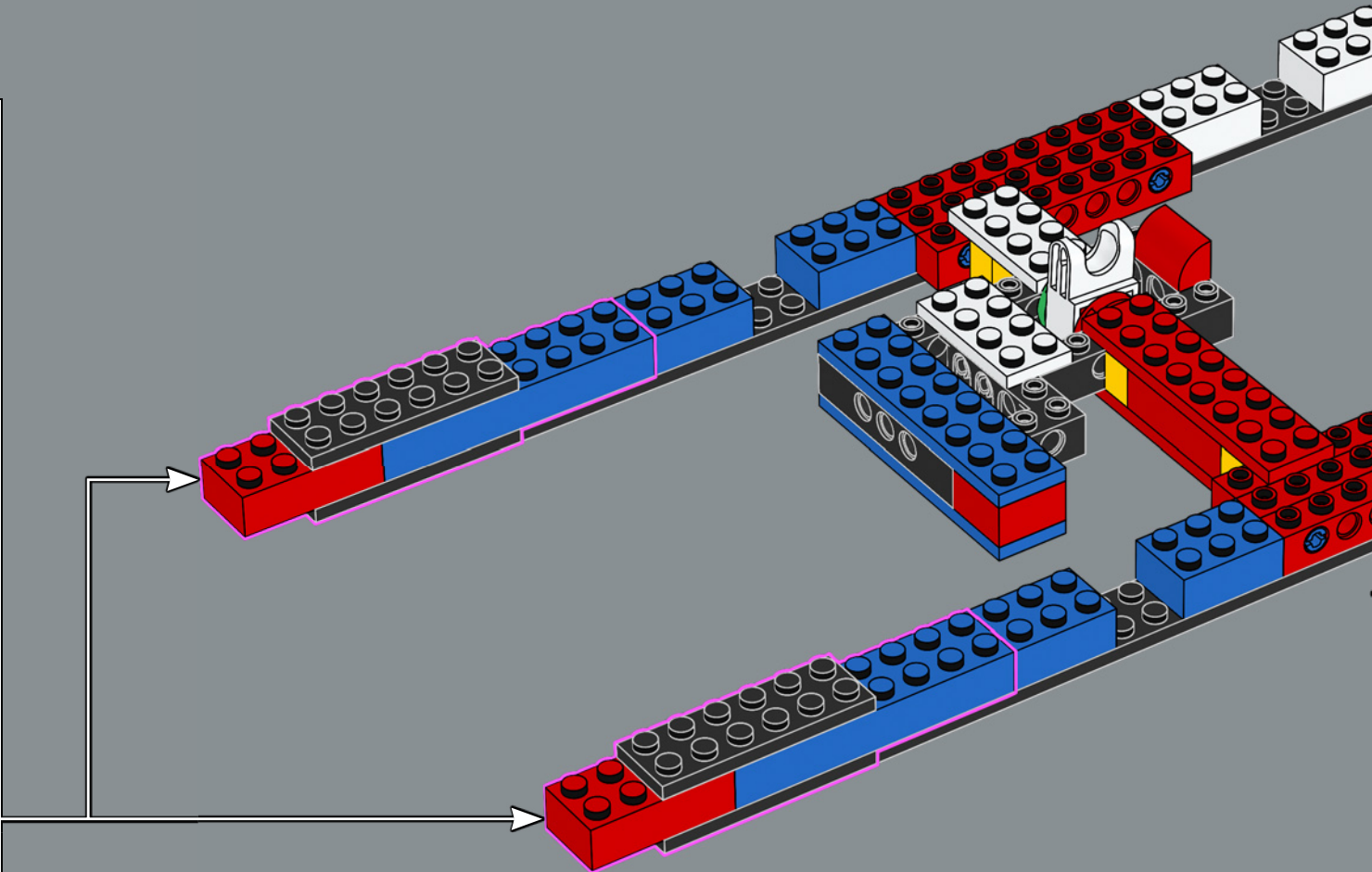
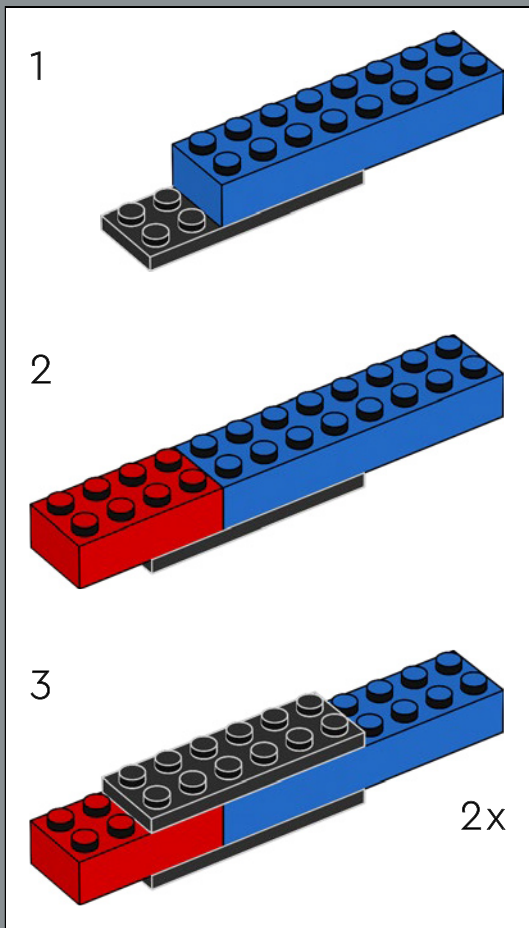

25

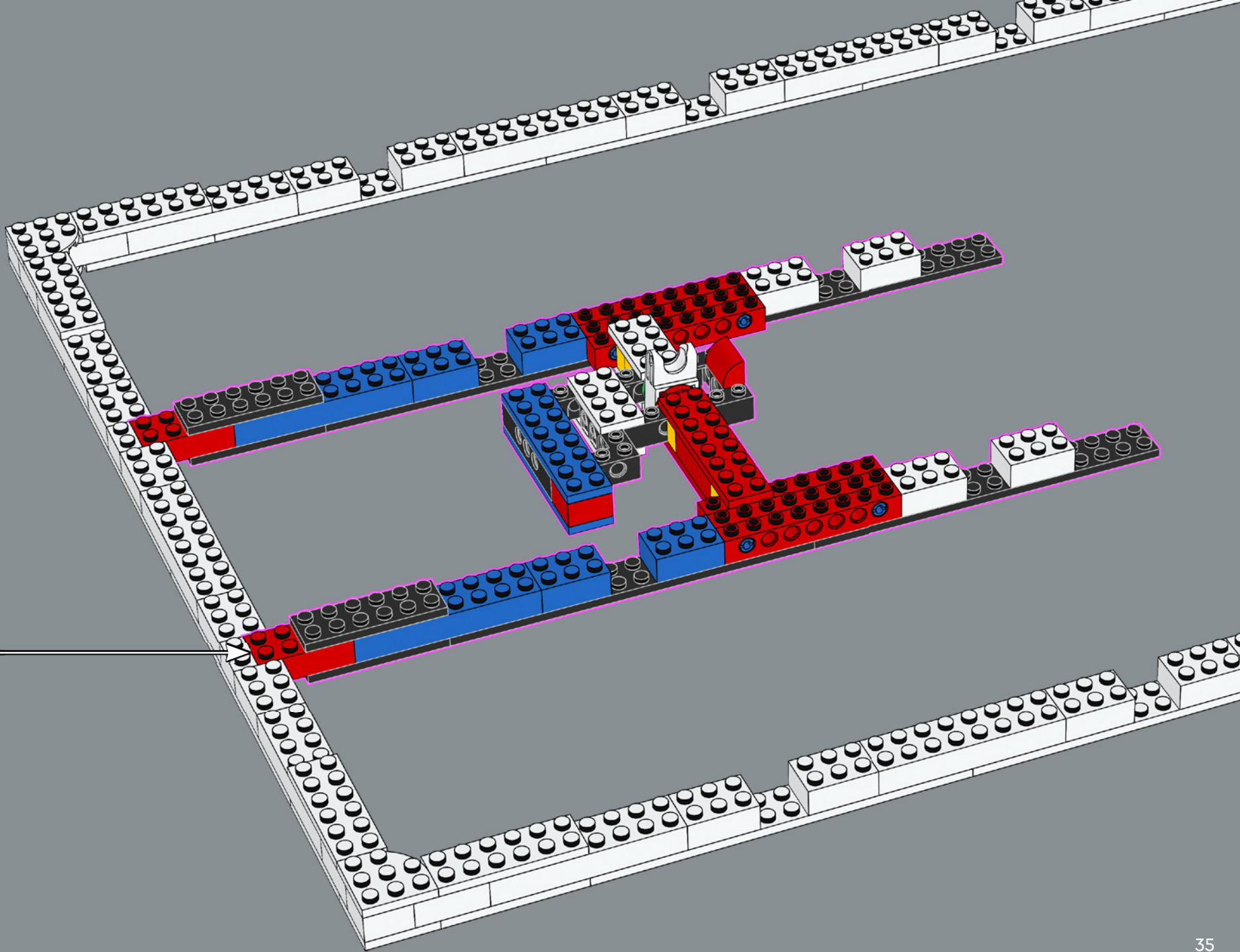

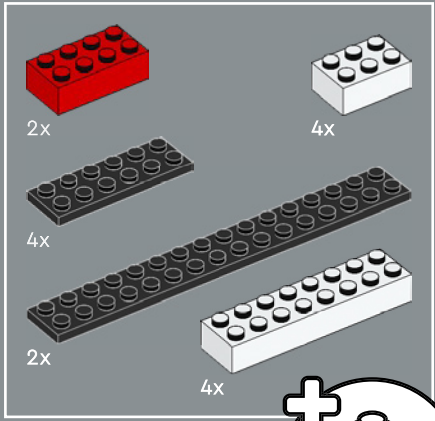
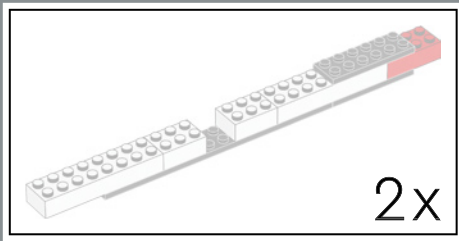

26

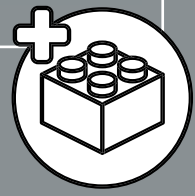

1

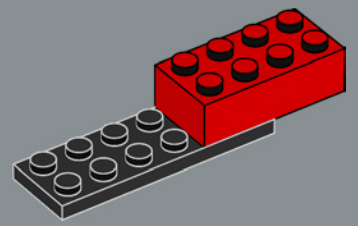

2

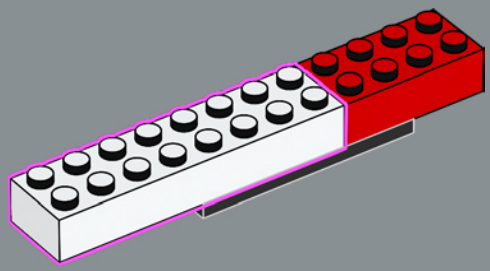

3

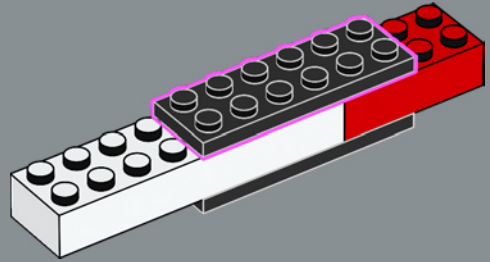

4

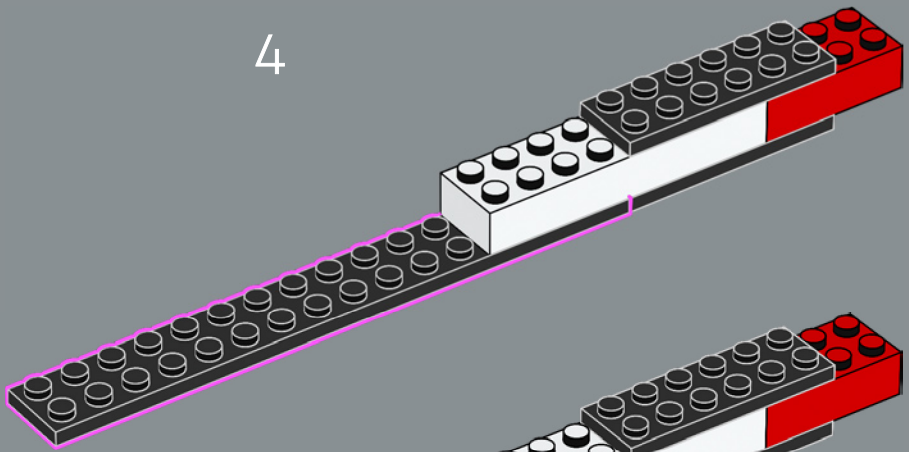

5

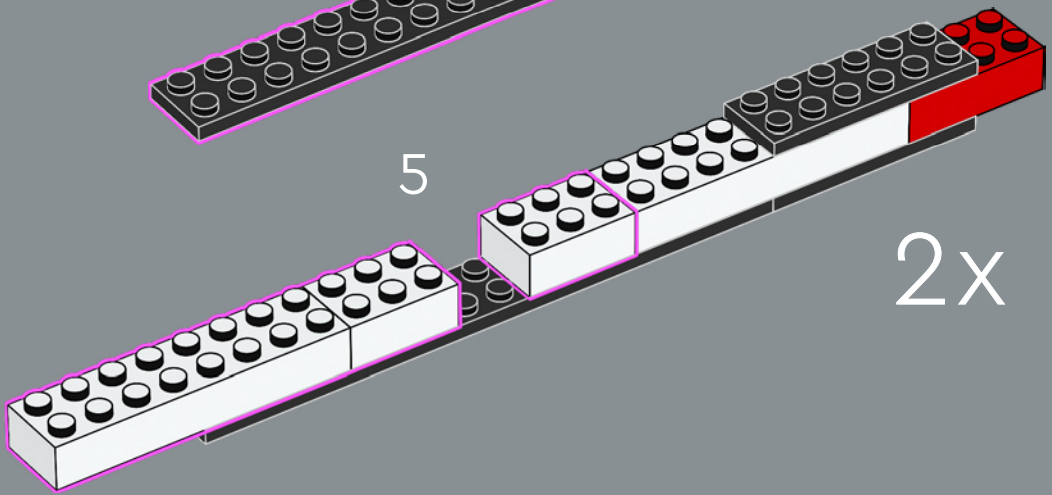

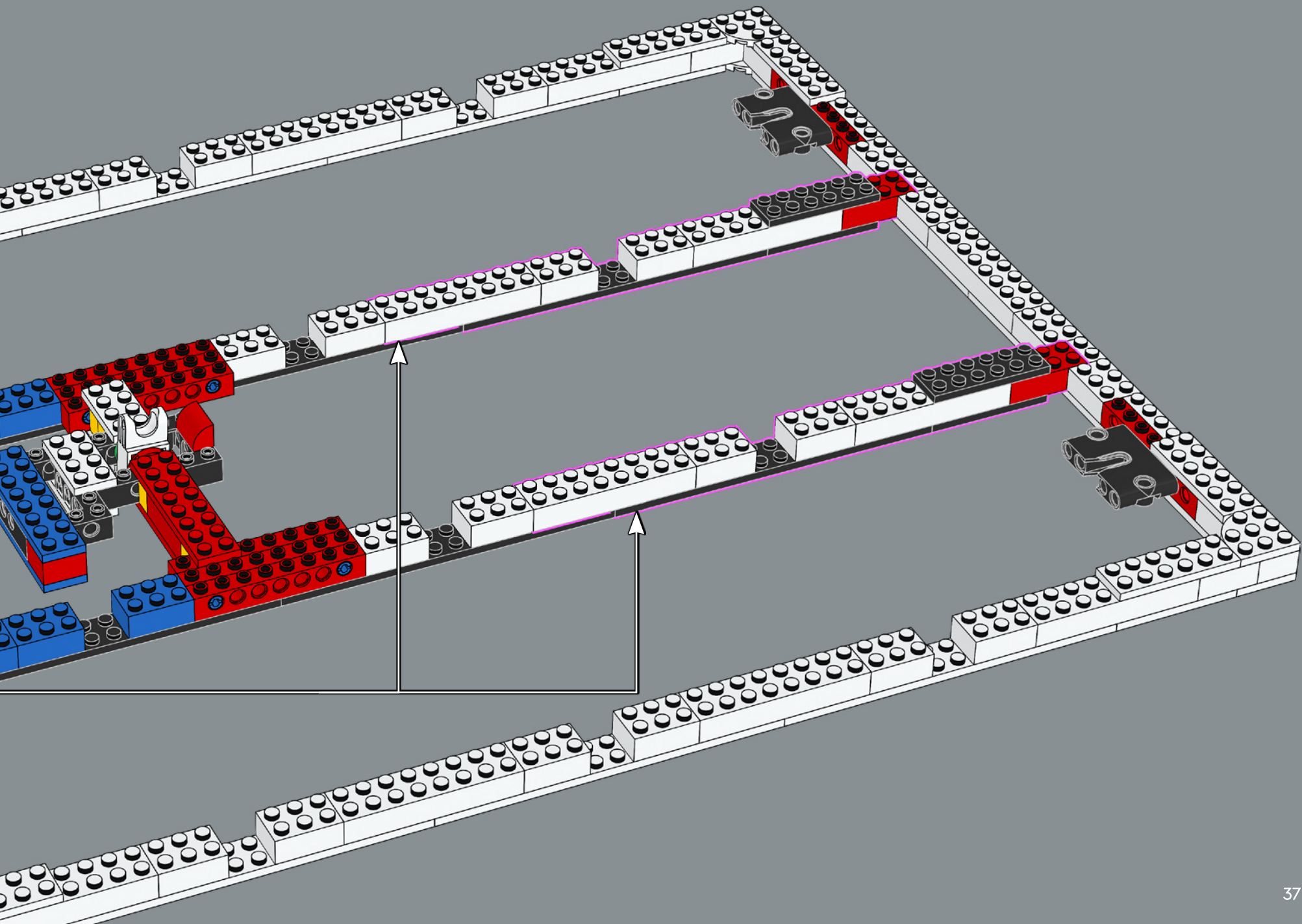

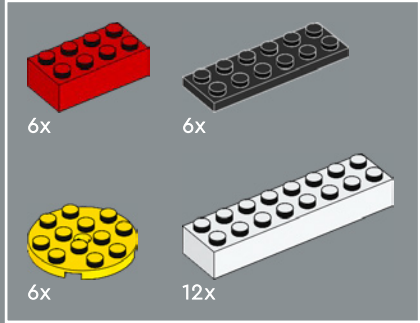
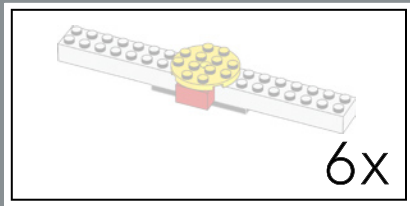

27

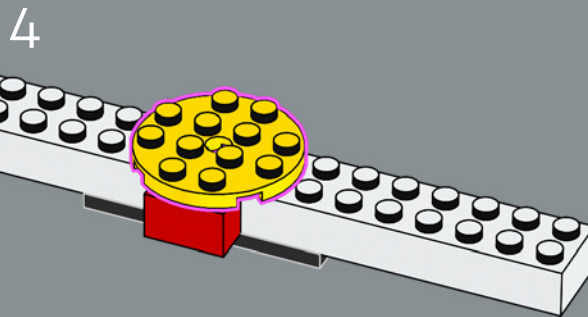
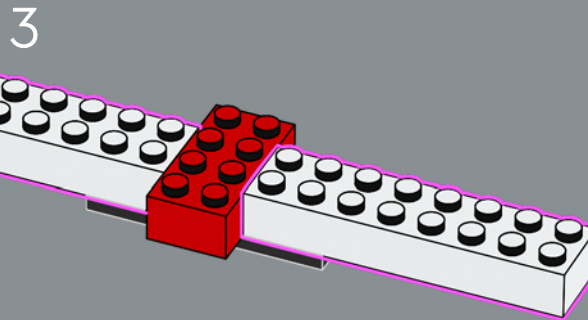
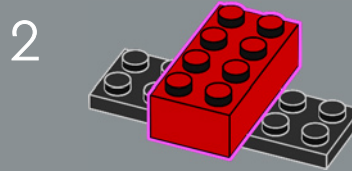
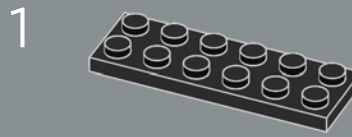

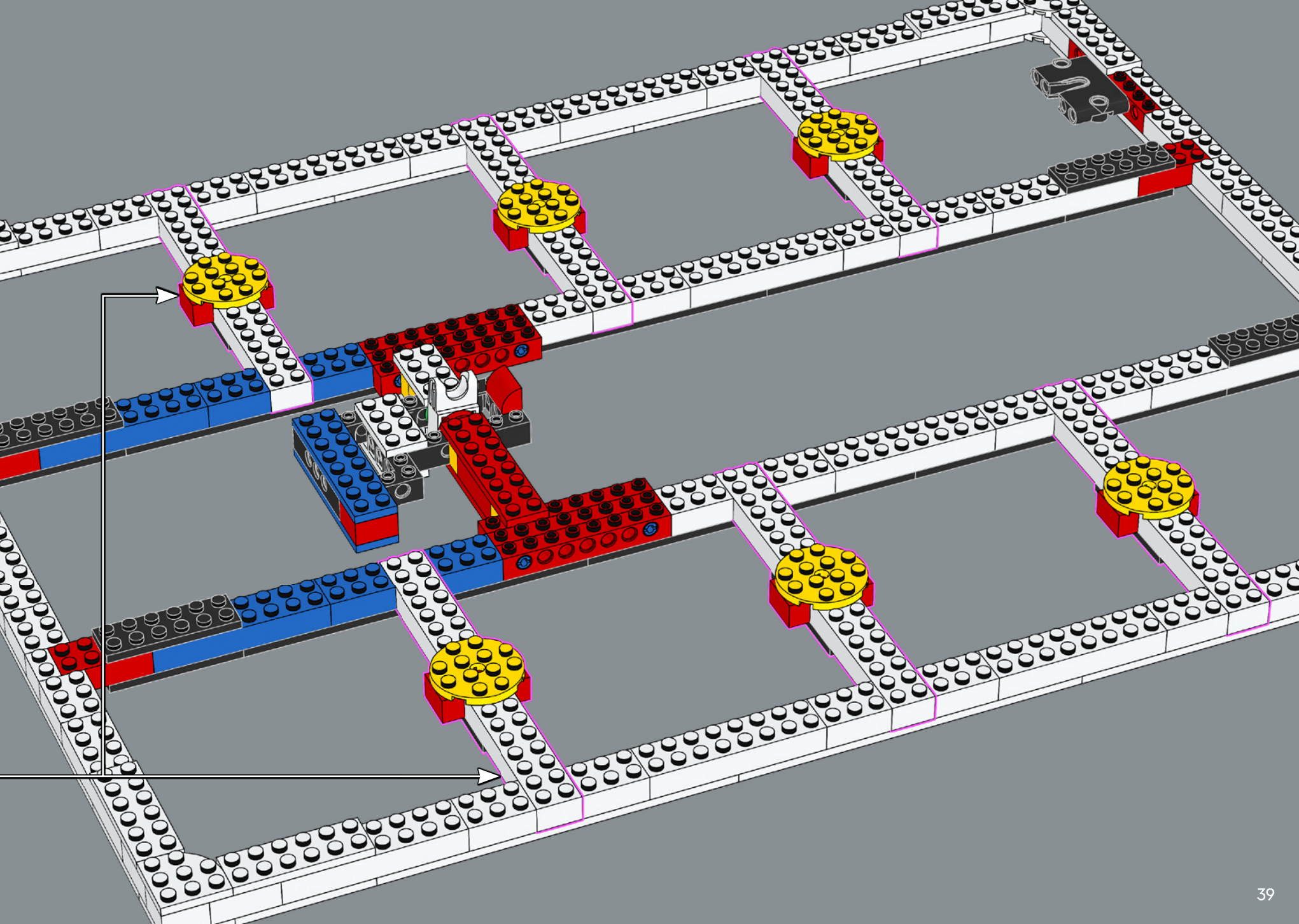

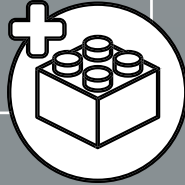
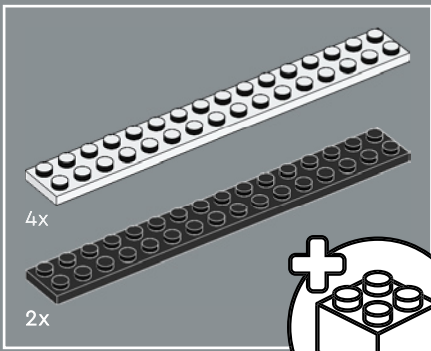

28

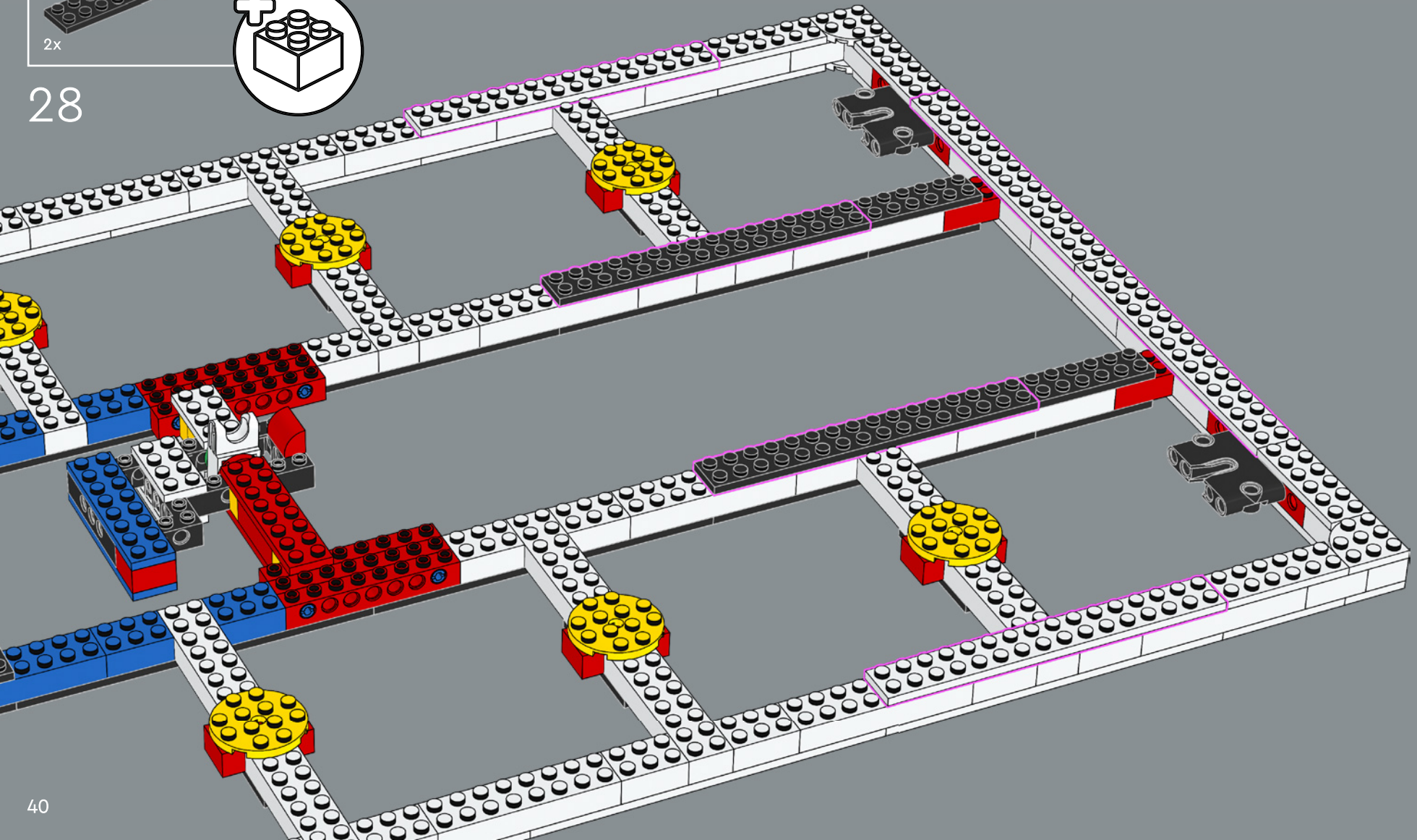



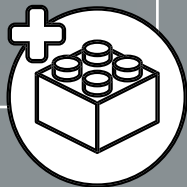
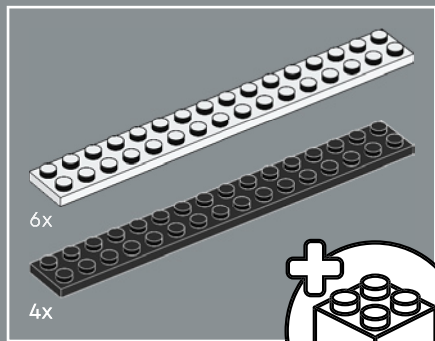

29

The colors used in this model were chosen to mimic the limited colors of both printed comics and LEGO® elements in the 1960s!

Les couleurs utilisées dans ce modèle ont été choisies pour imiter les couleurs limitées des bandes dessinées et des éléments LEGO® des années 1960 !

Los colores utilizados en este modelo se eligieron para replicar los limitados tonos tanto de los cómics impresos como de los elementos LEGO® en la década de 1960.

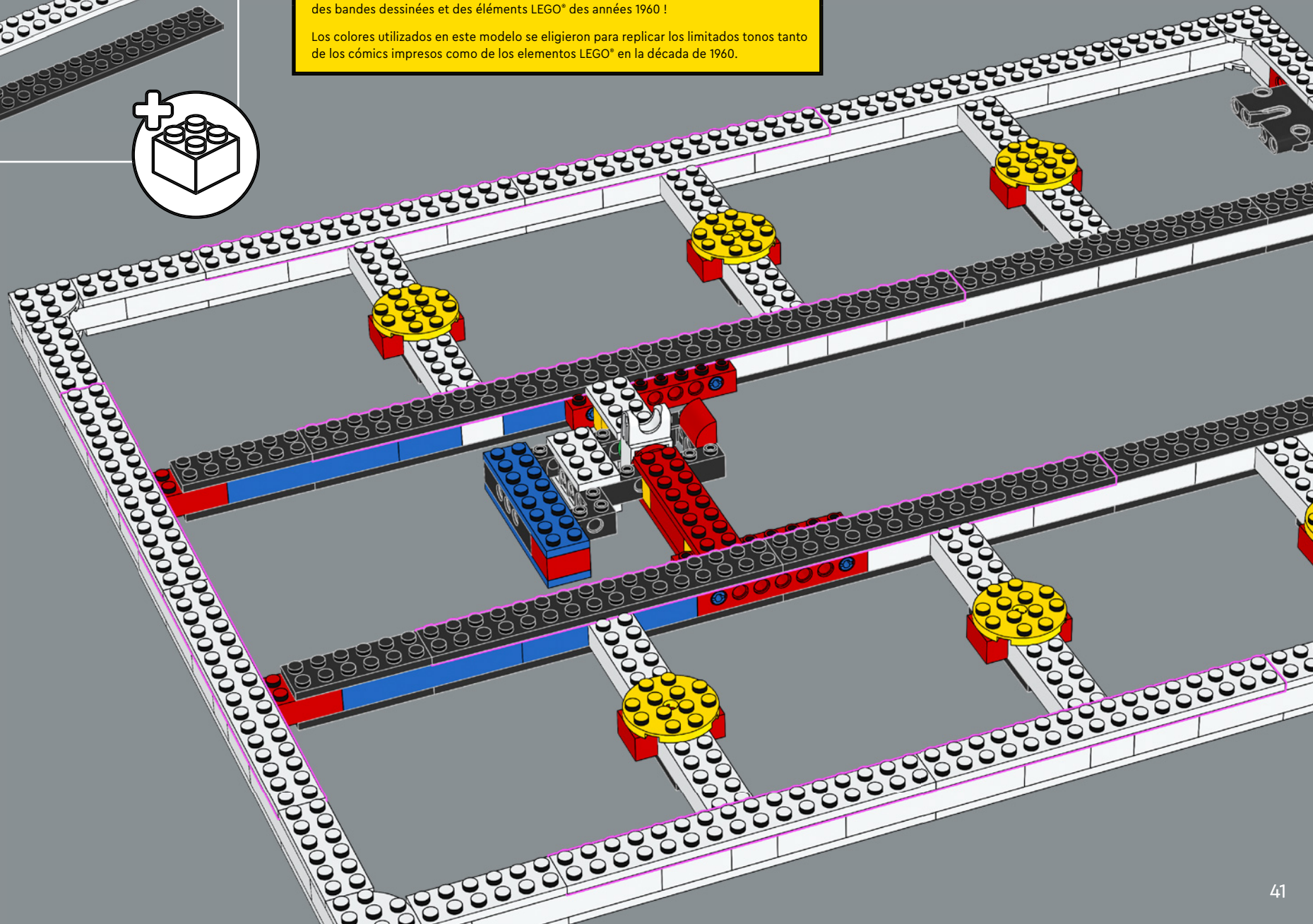



30

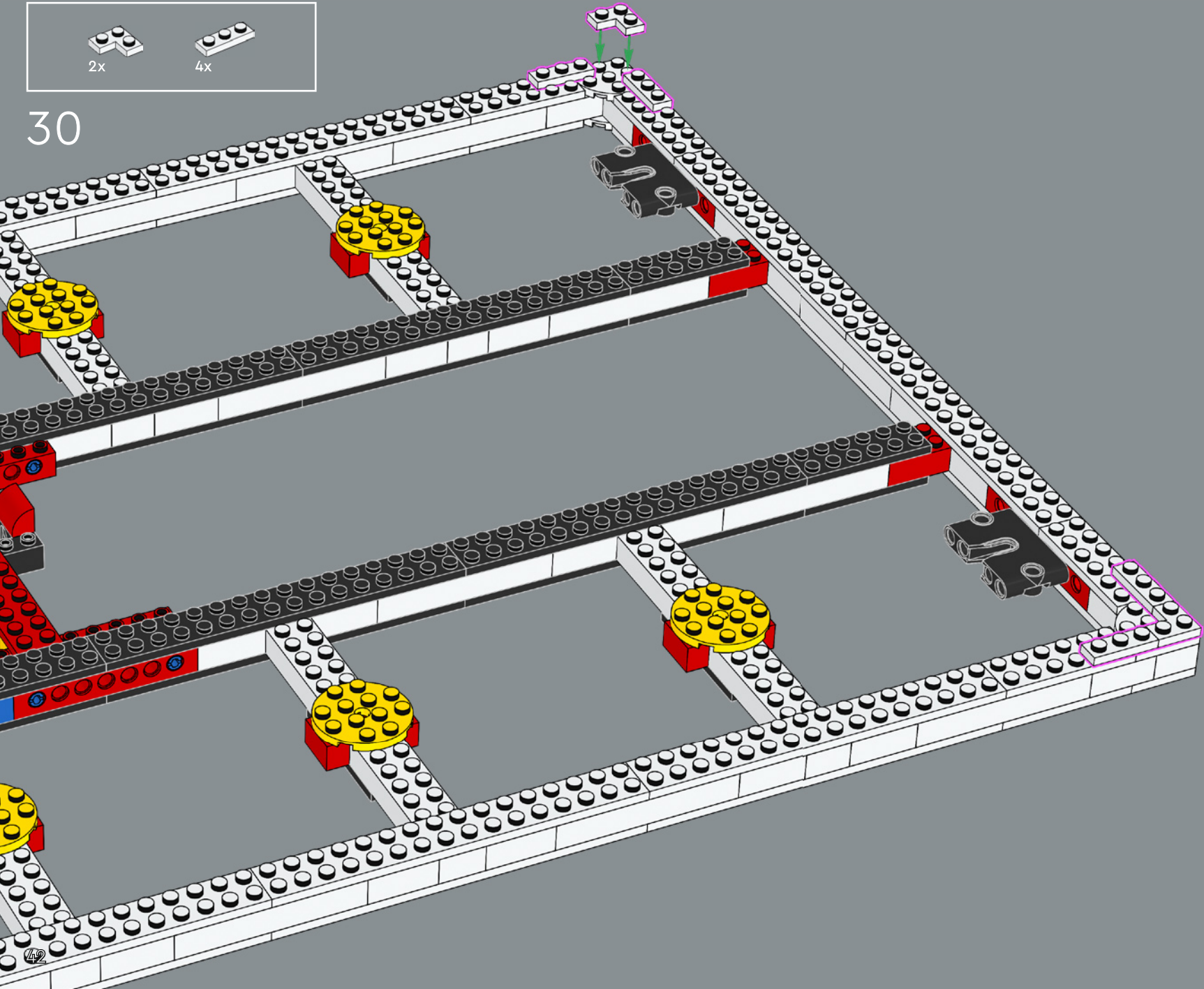

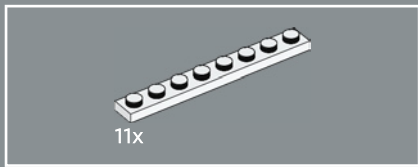

31

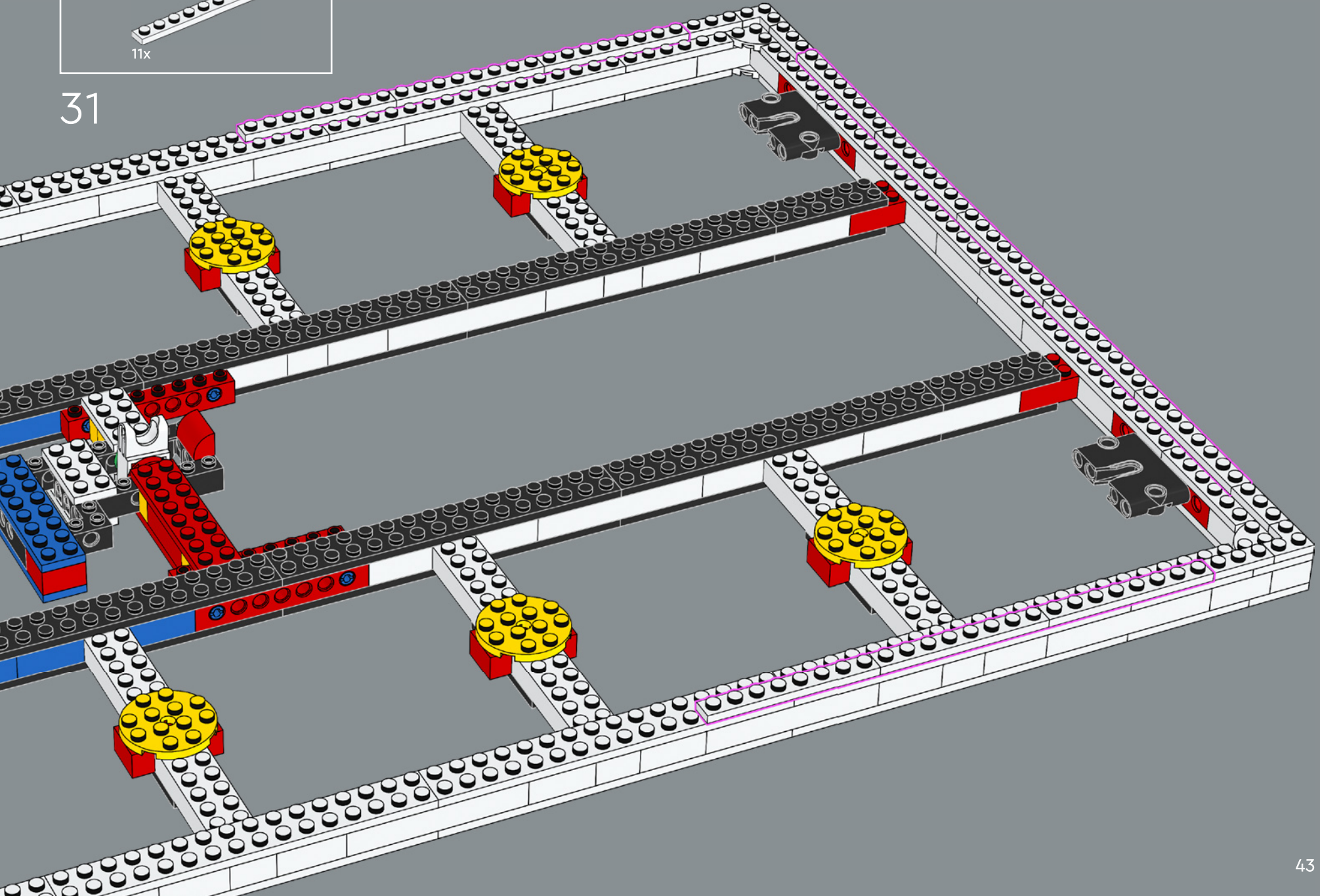

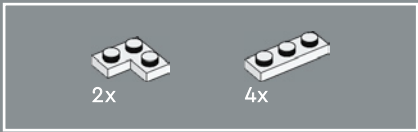

32

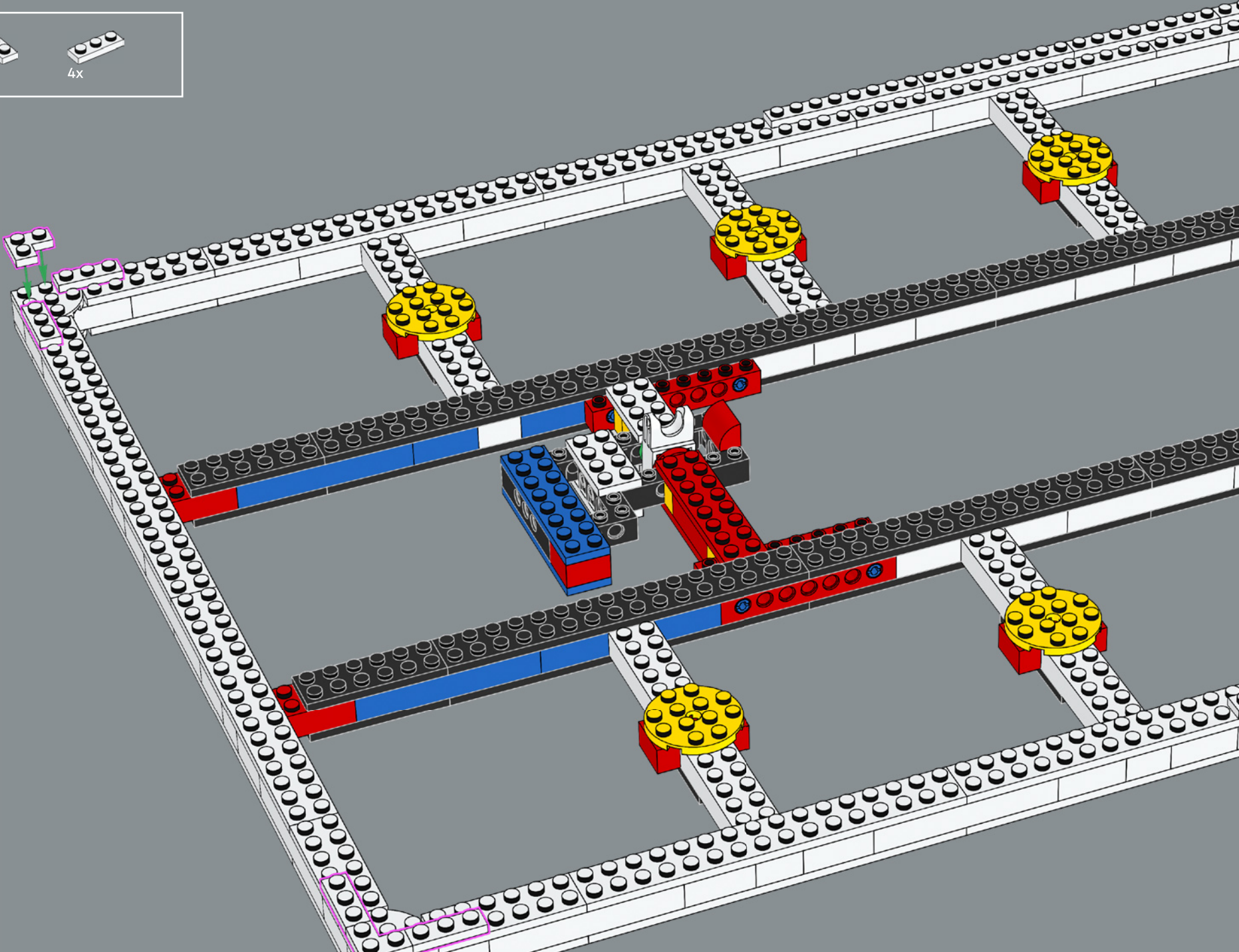

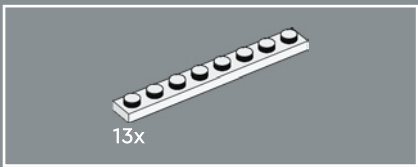

33

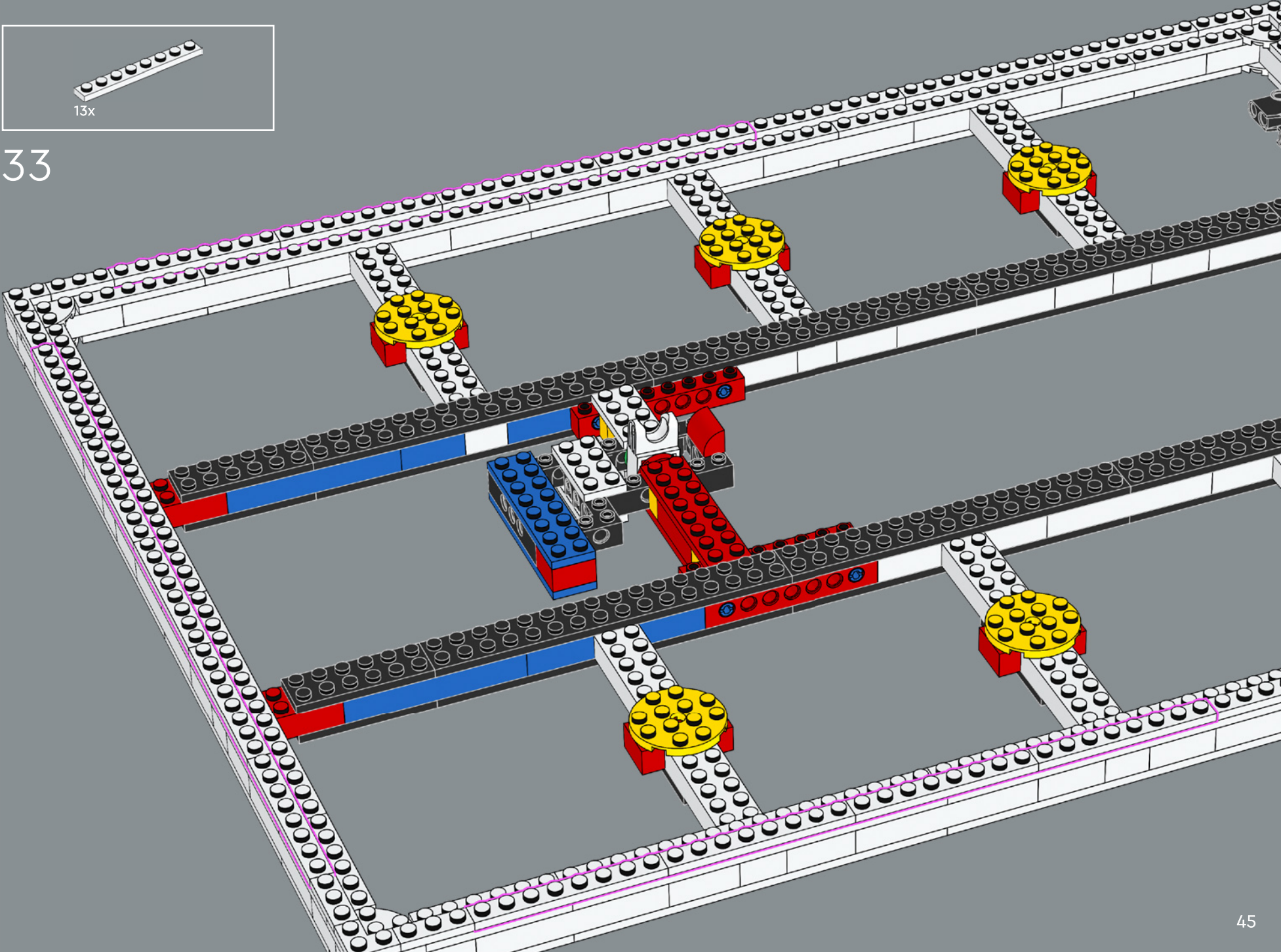

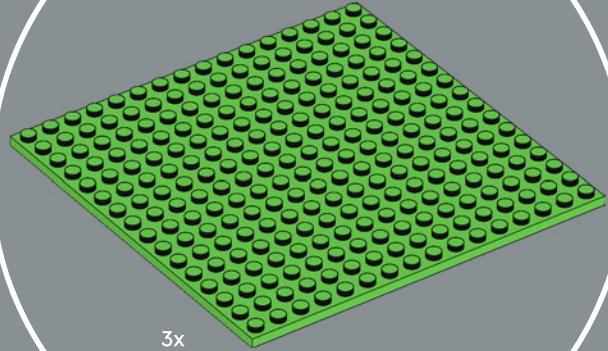
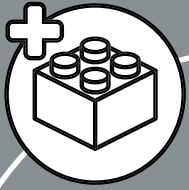

3x

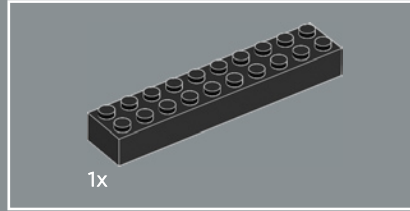
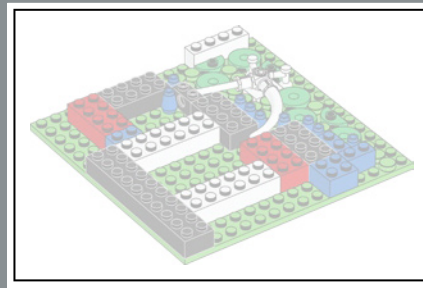

1x

34

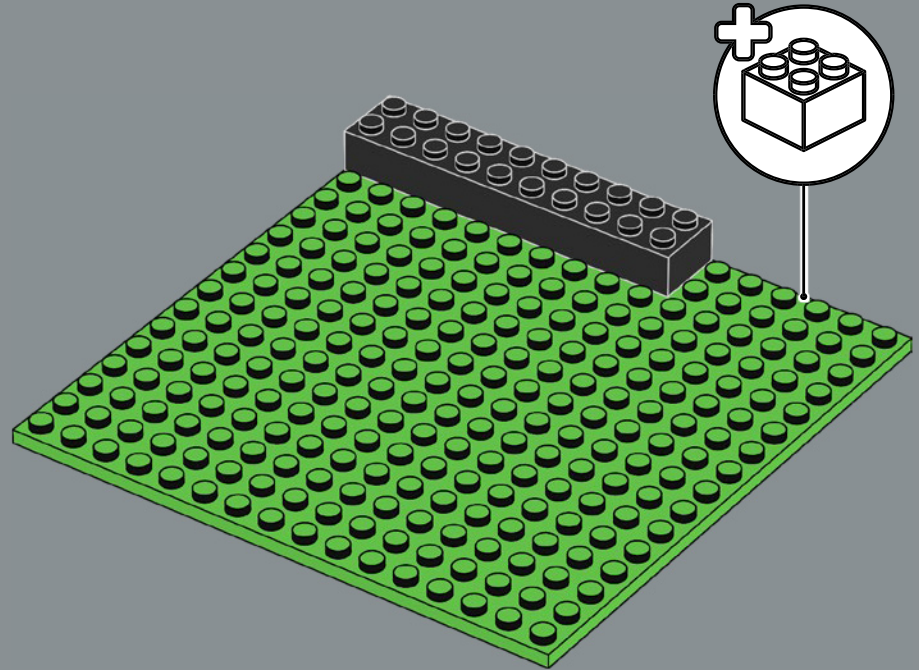

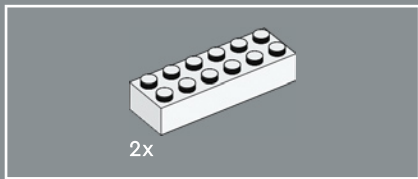

35

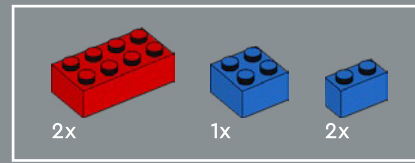
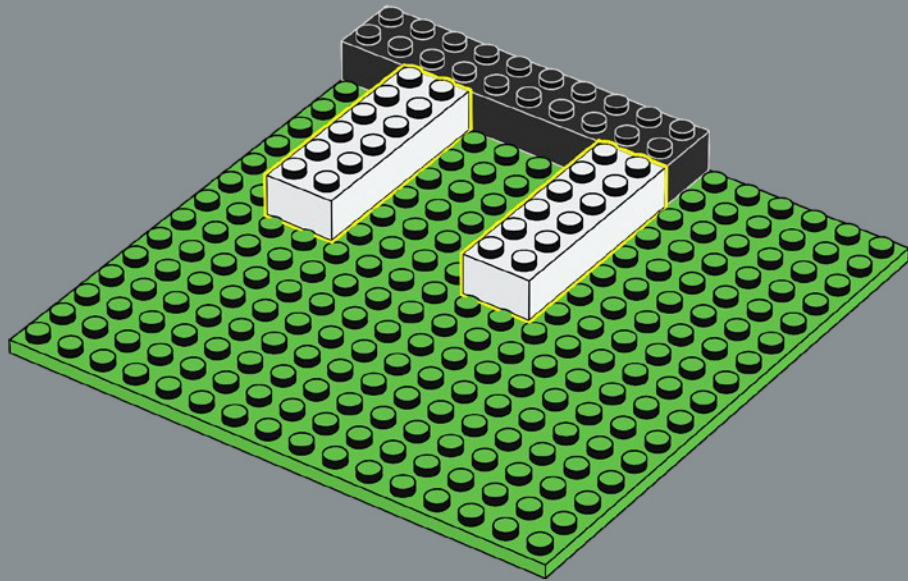

36

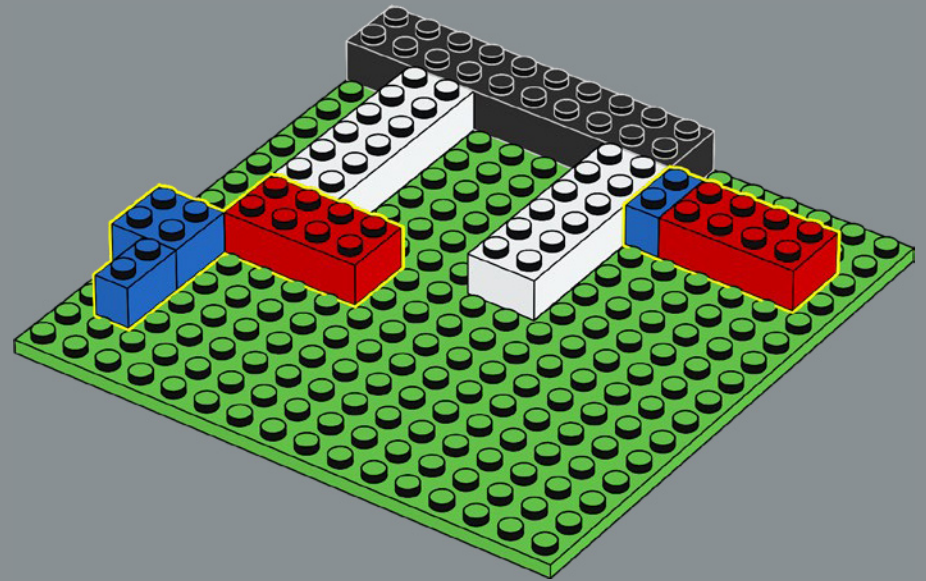

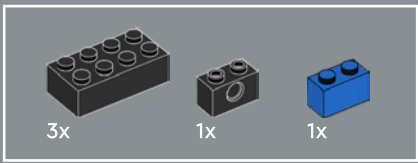

37

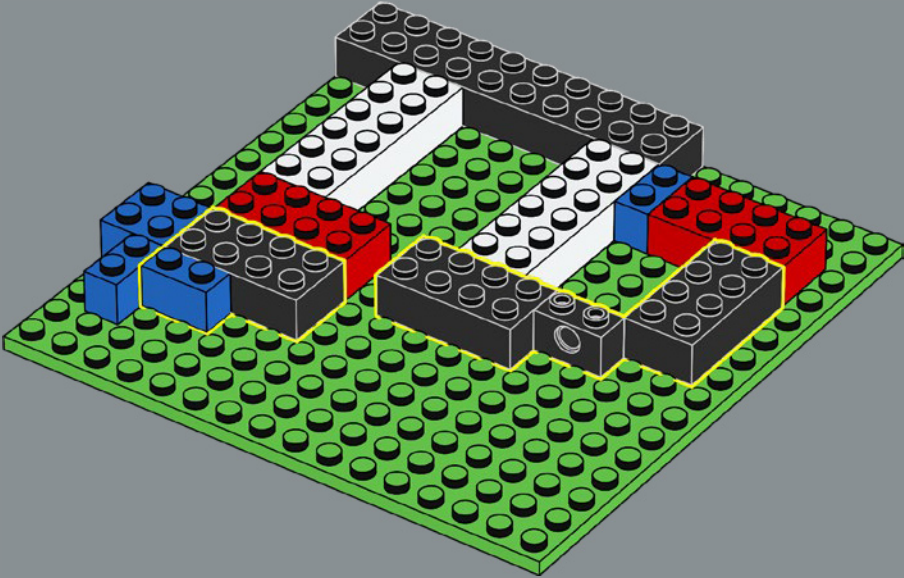

38

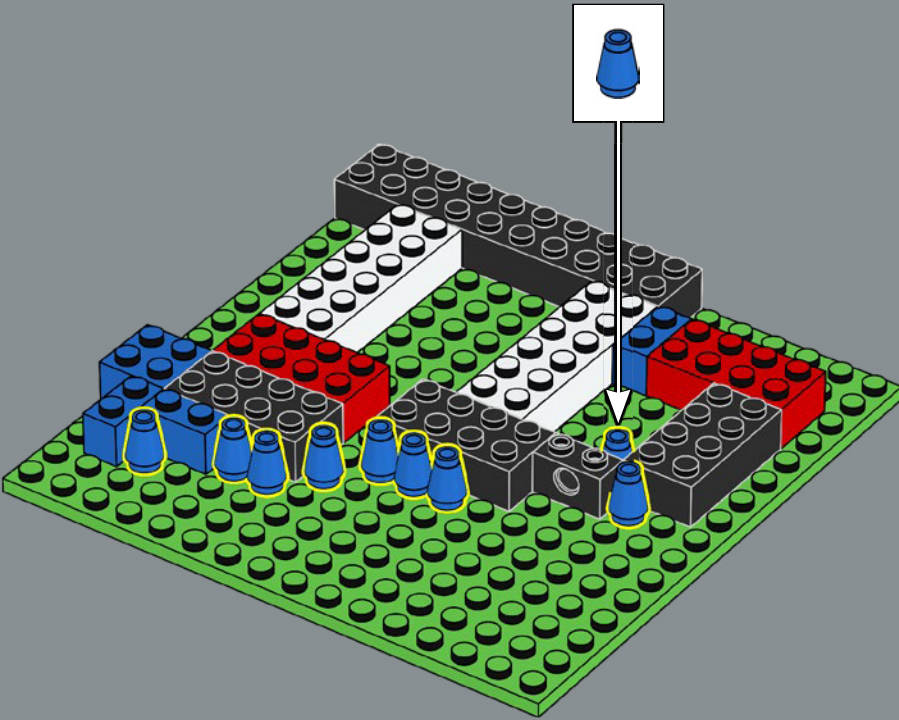



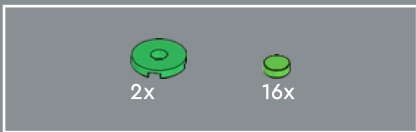

39



A note to builders – The crowbar element can be used to remove the occasional tile if you make a mistake! Take it from us – you've never seen a build like this before ...

Remarque à l'attention des constructeurs – le pied-de-biche peut être utilisé pour retirer une tuile occasionnelle si vous faites une erreur ! Croyez-nous – vous n'avez jamais vu une construction comme celle-ci...

Nota para el constructor: El elemento de palanca puede utilizarse para quitar alguna que otra cubierta si te equivocas. Y créenos si te decimos que nunca has visto un modelo como este...

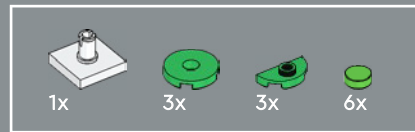
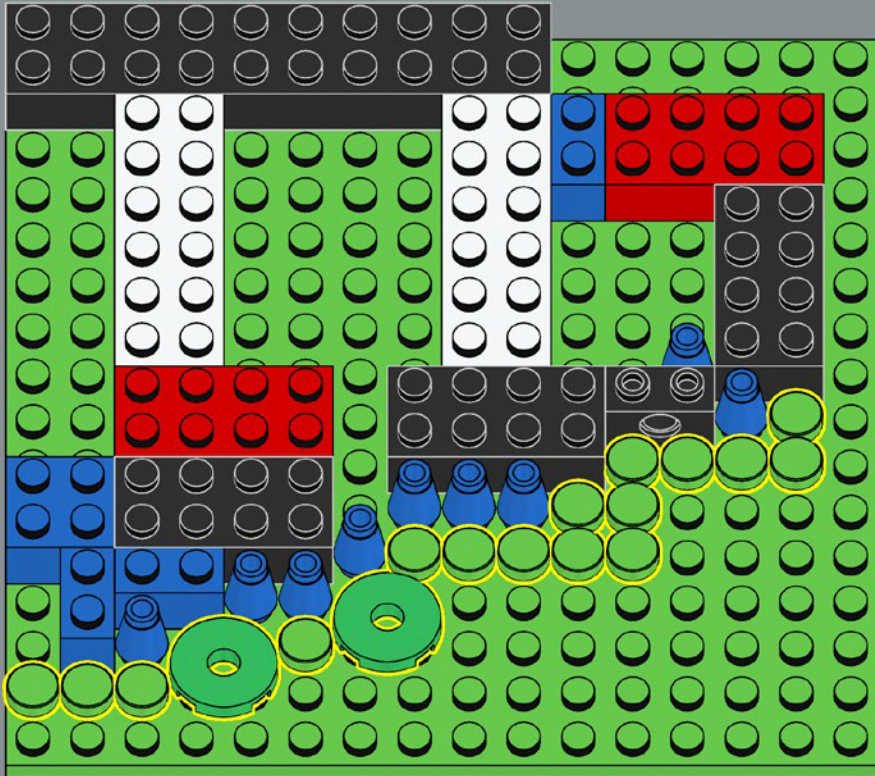

40

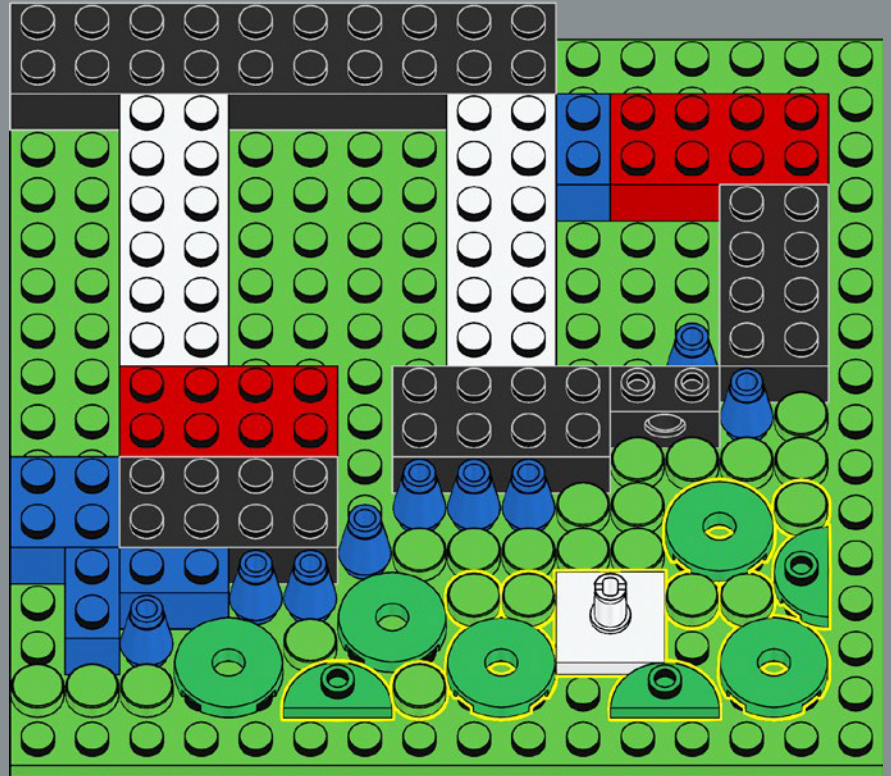



41

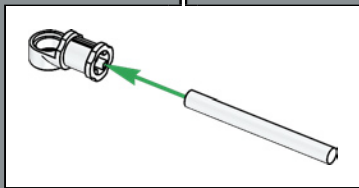
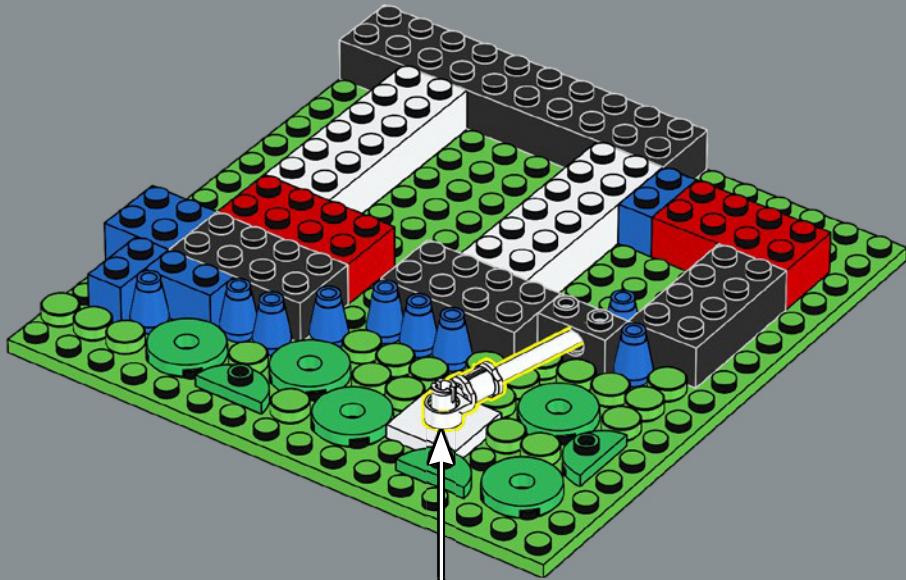

42

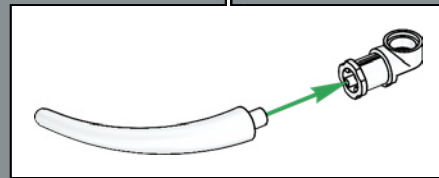
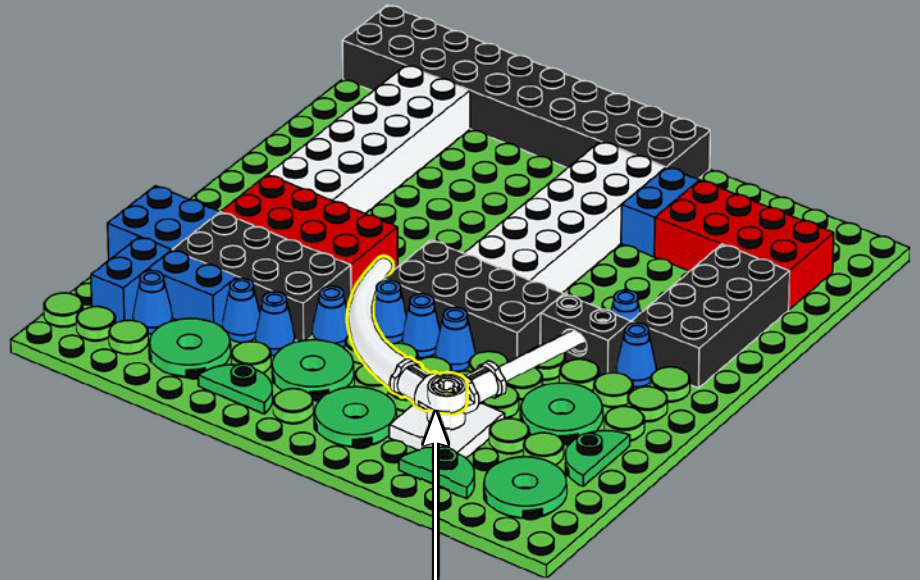



43

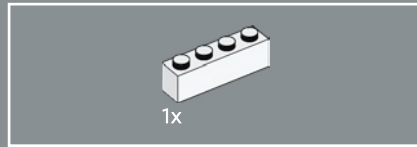
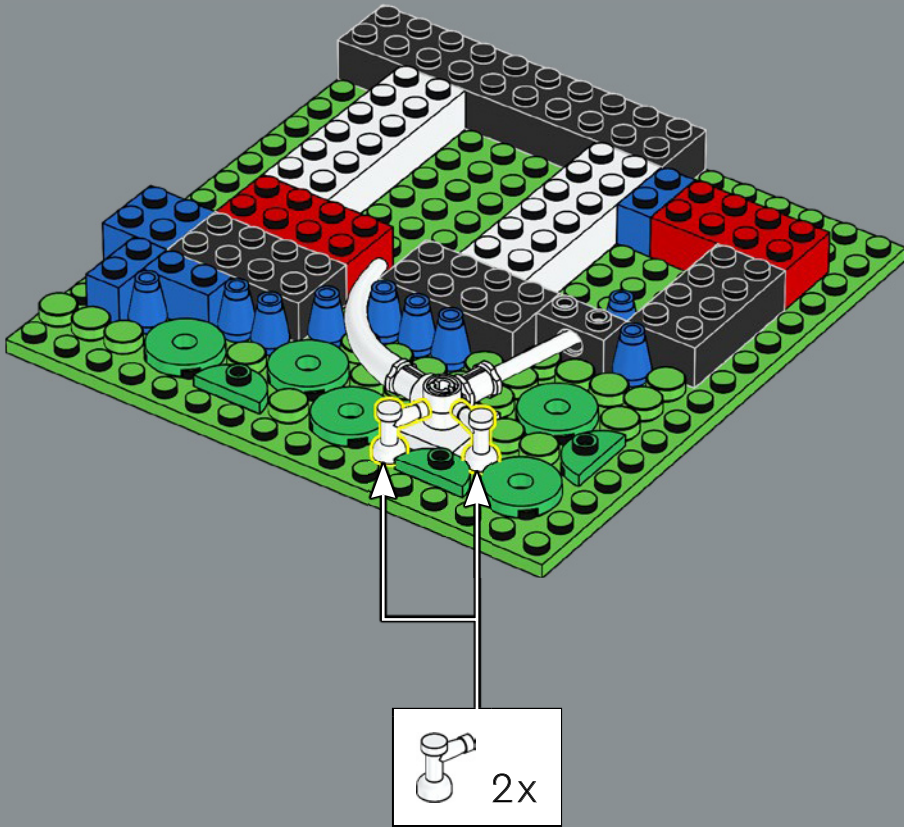

44

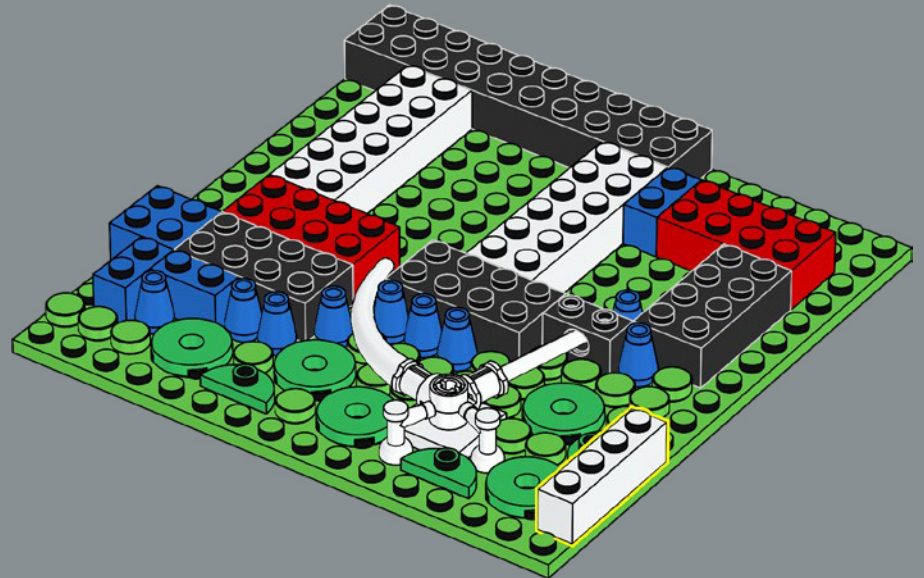

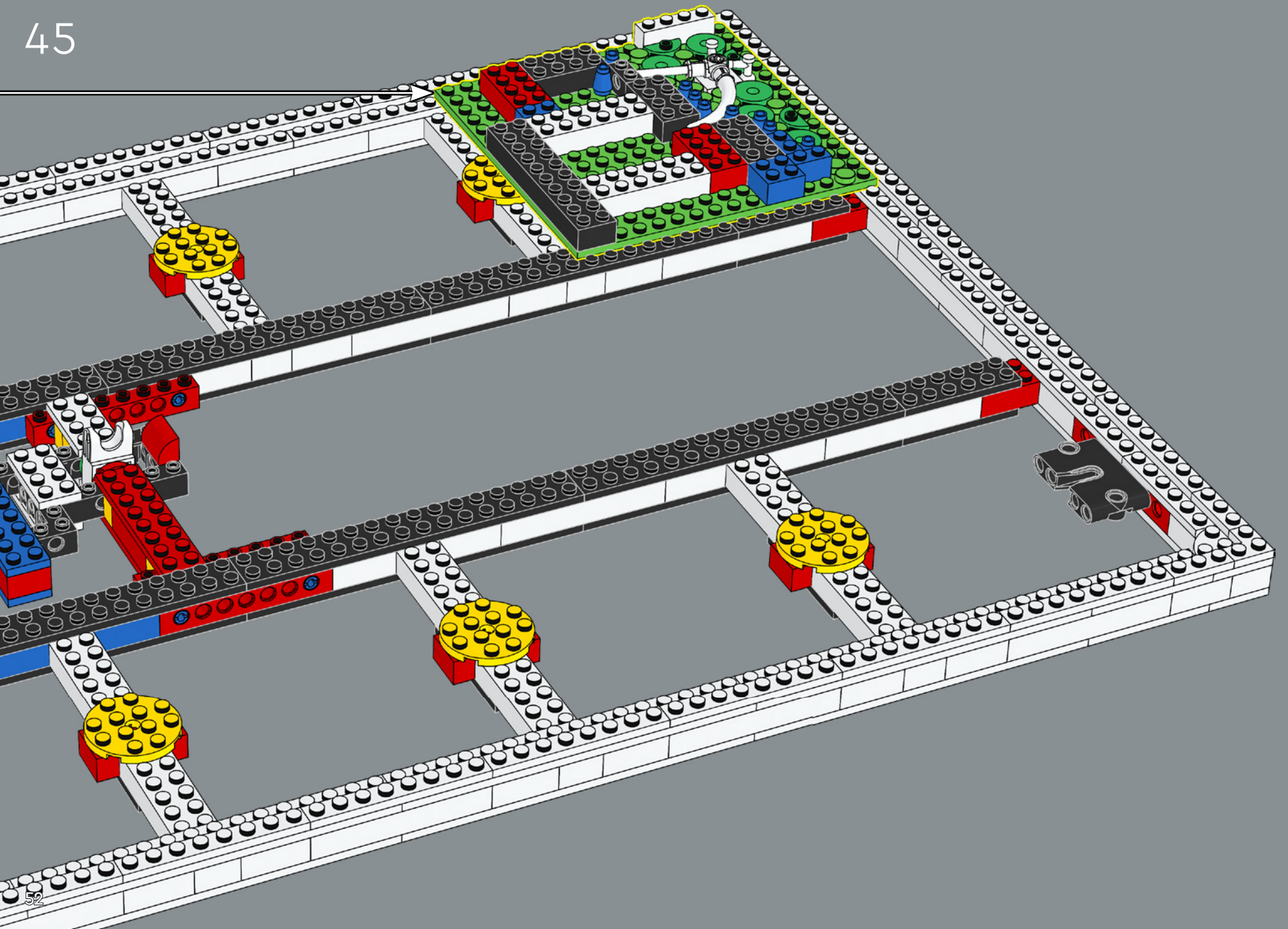

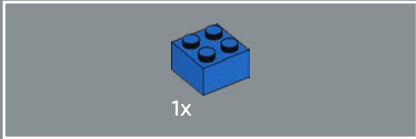
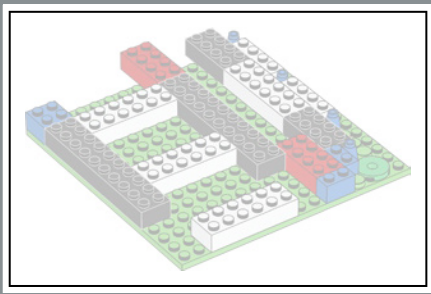

46

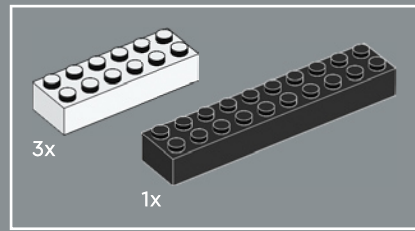
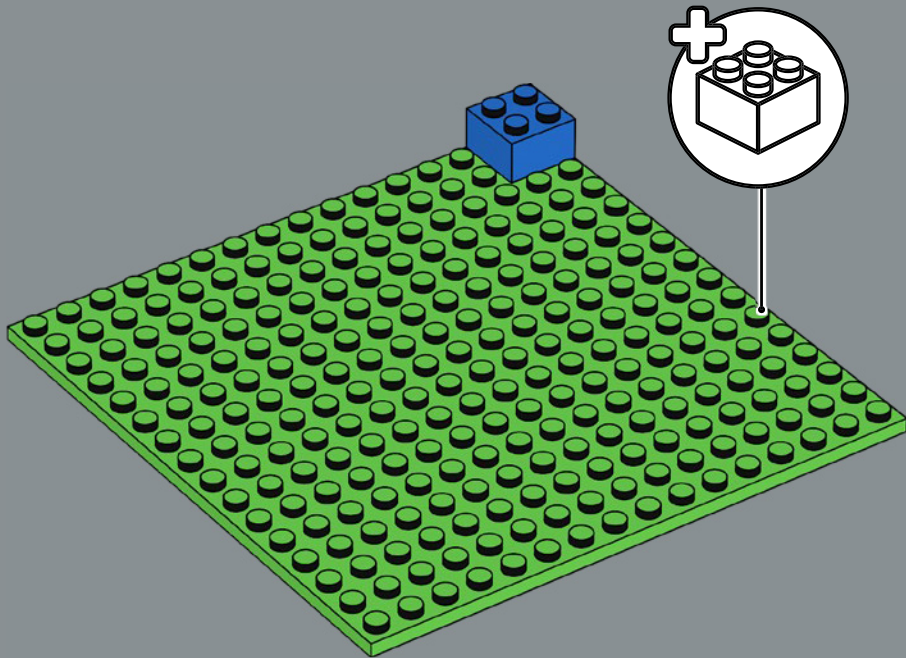

47

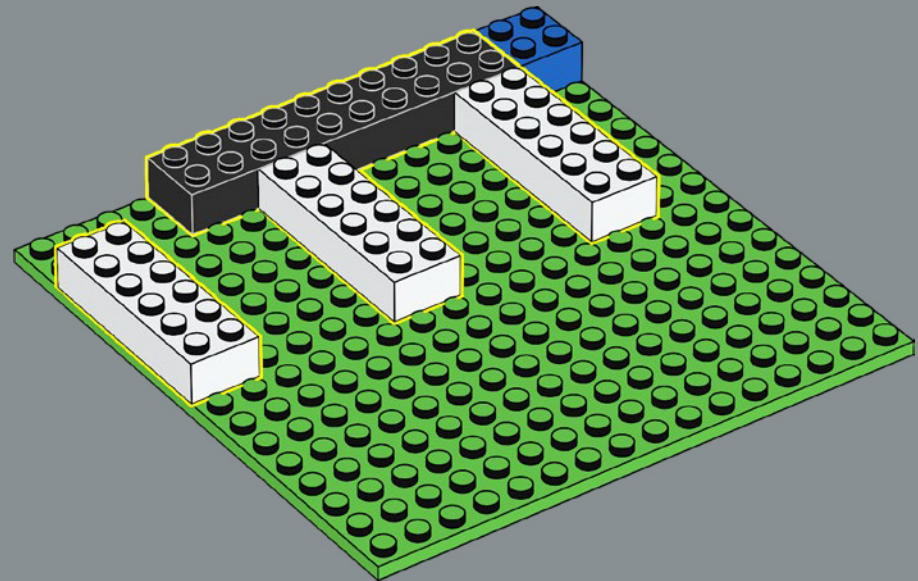

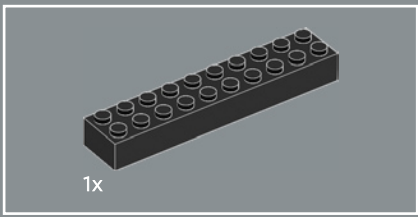

48

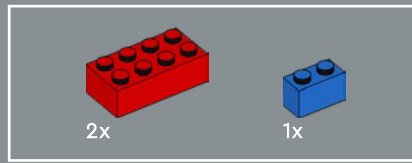
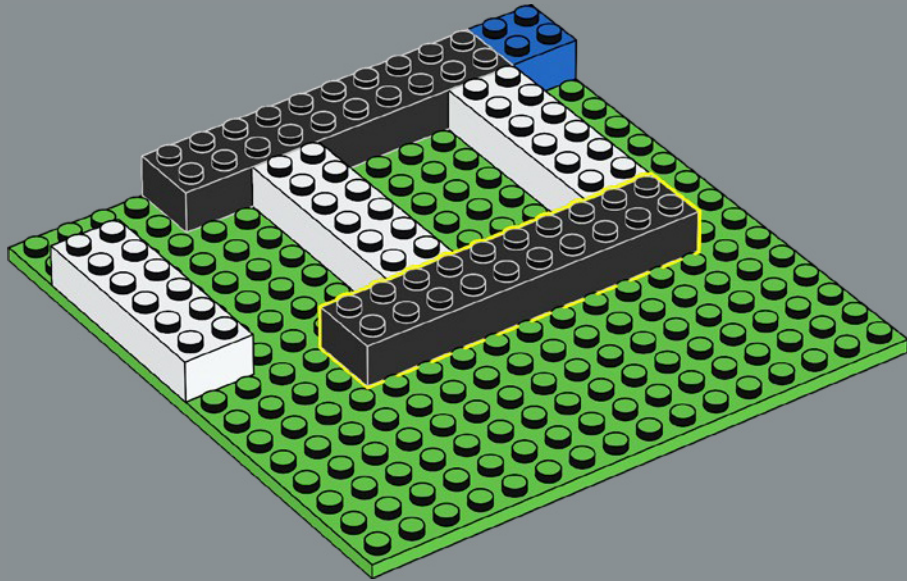

49

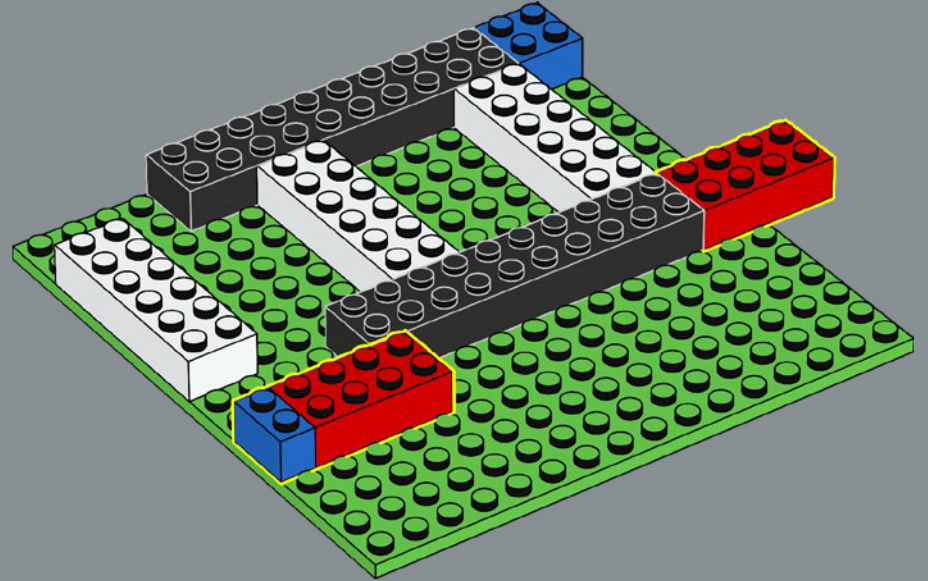

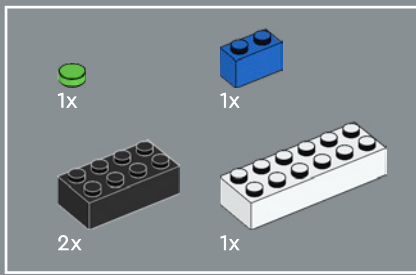

50

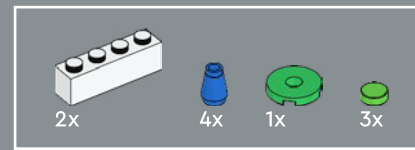
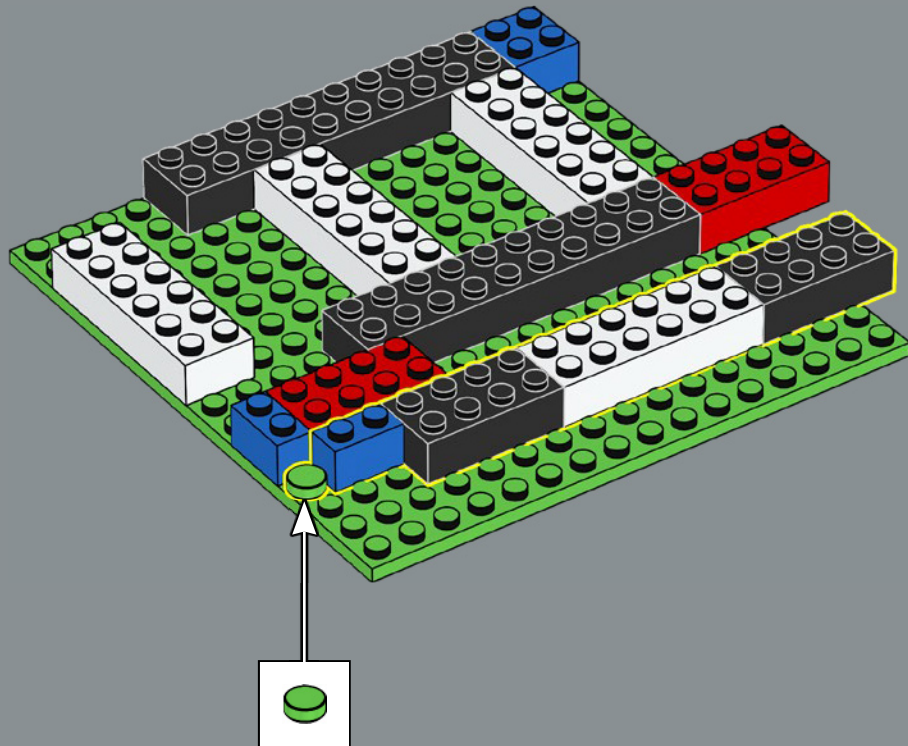

51

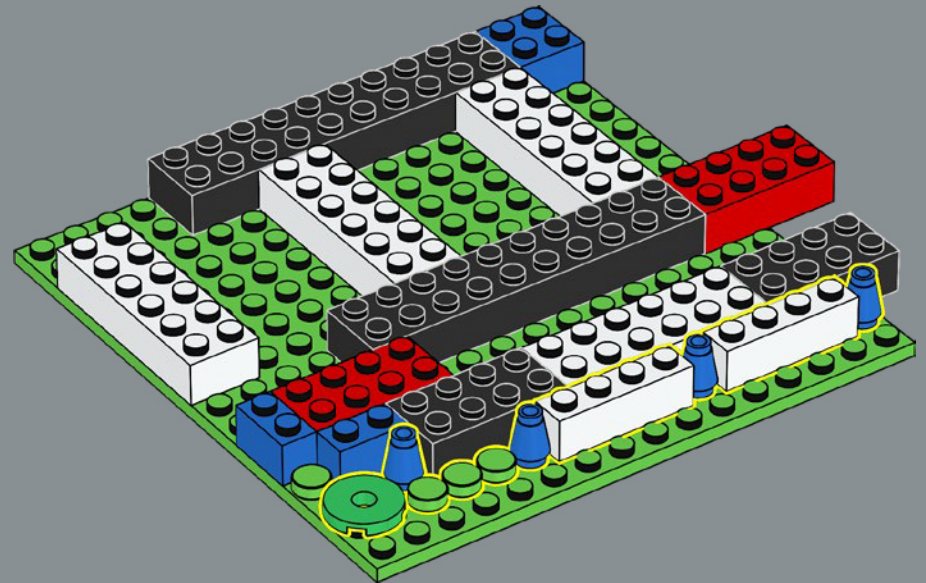

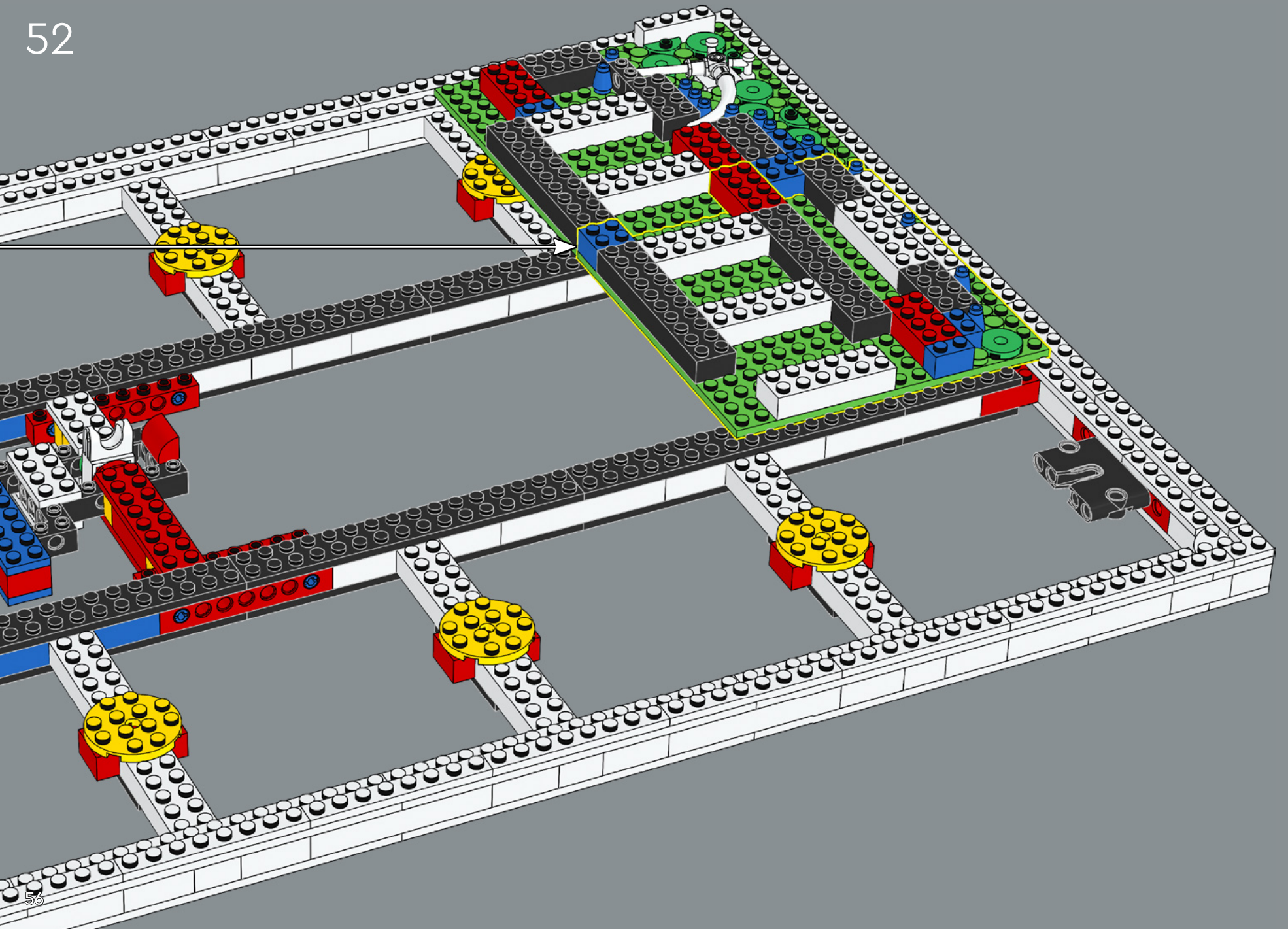



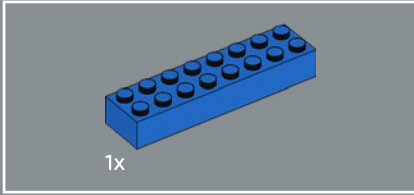
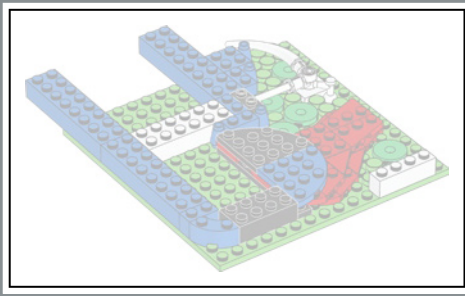

53

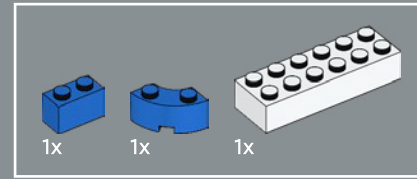
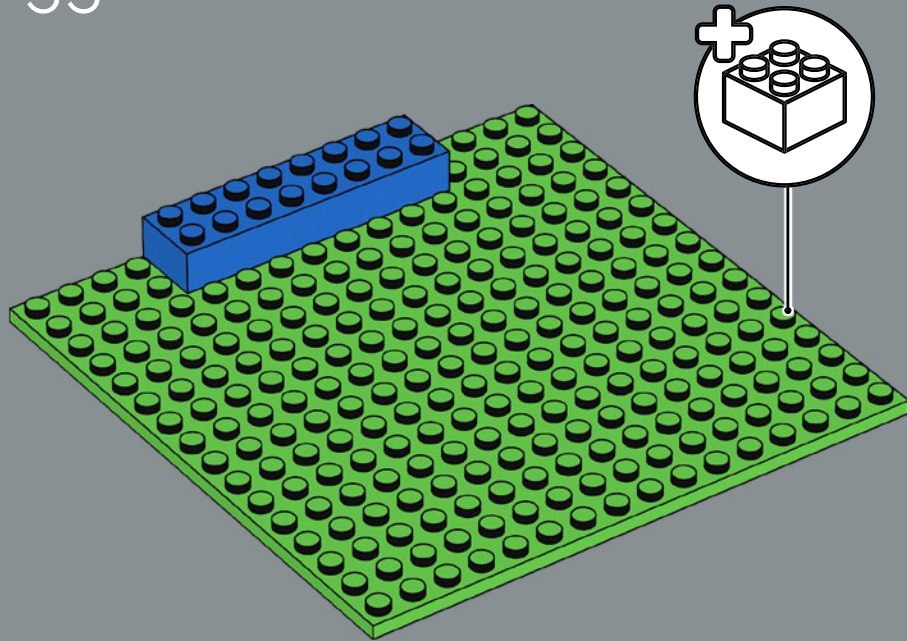

54

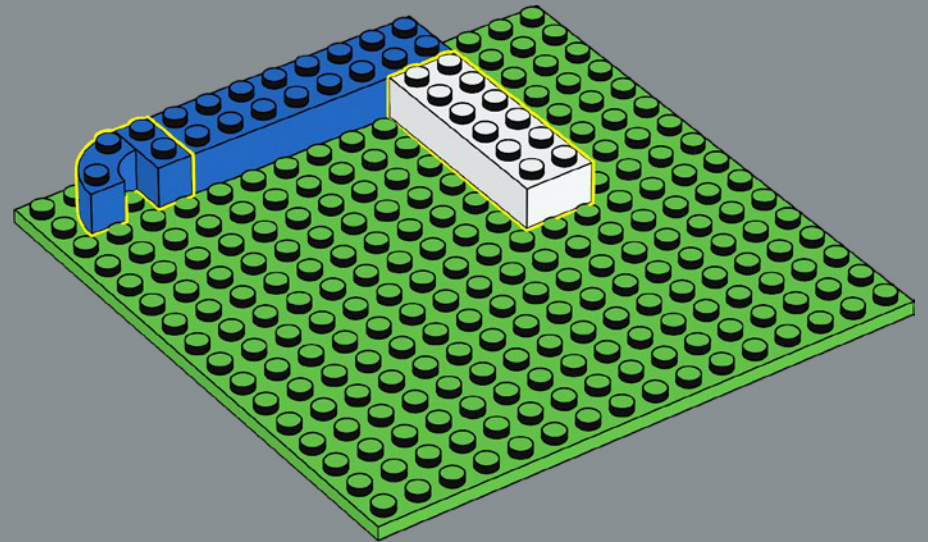

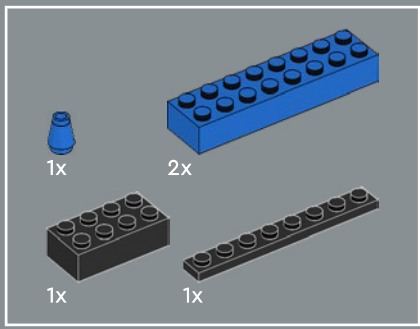

55

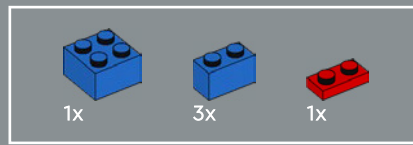
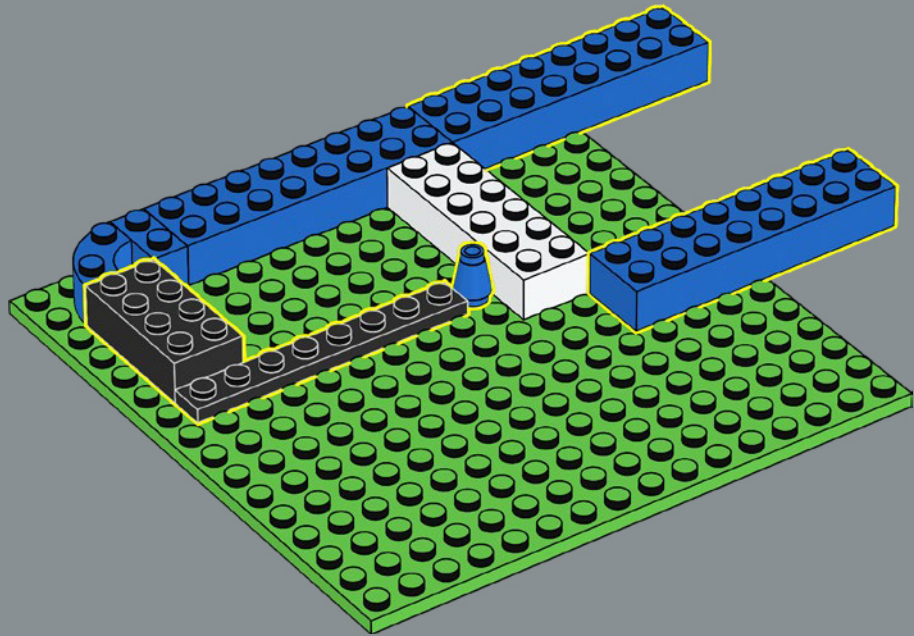

56

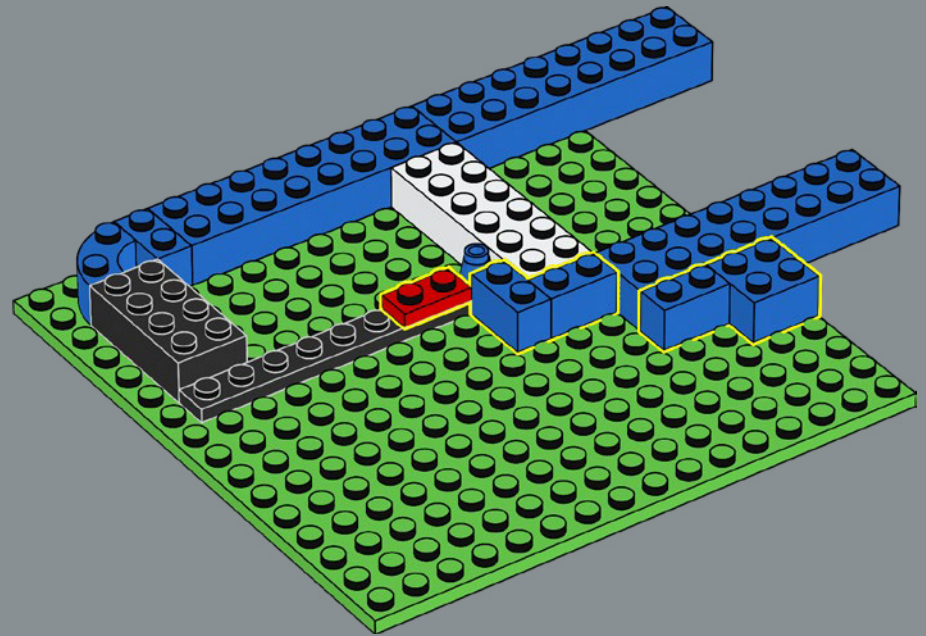

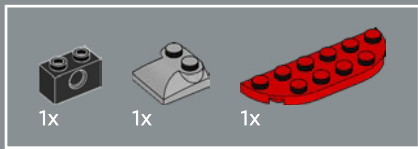

57

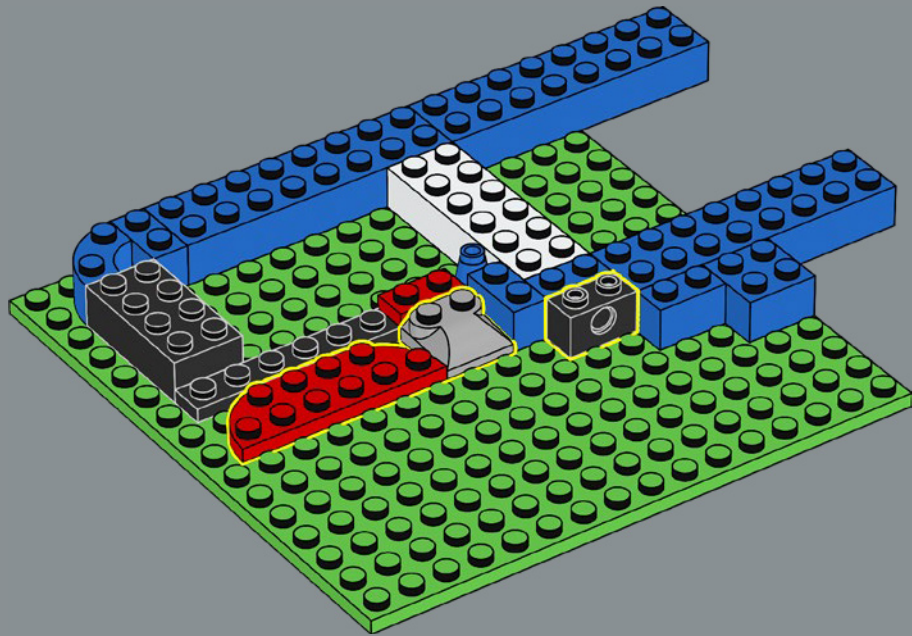

58

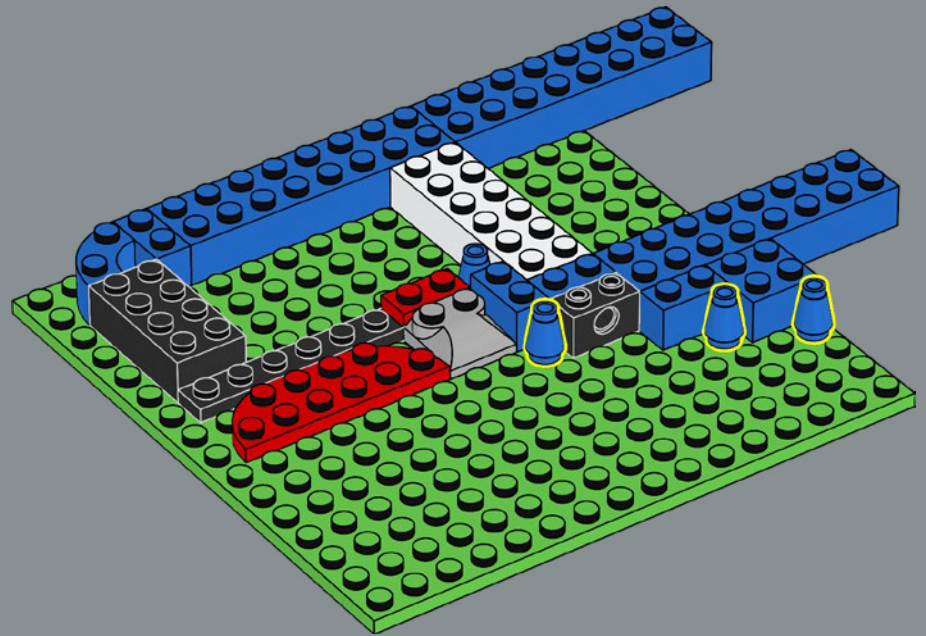

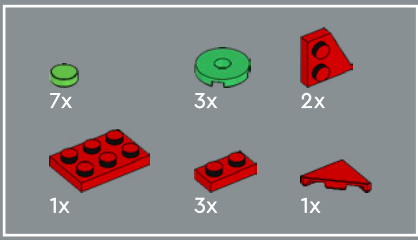

59

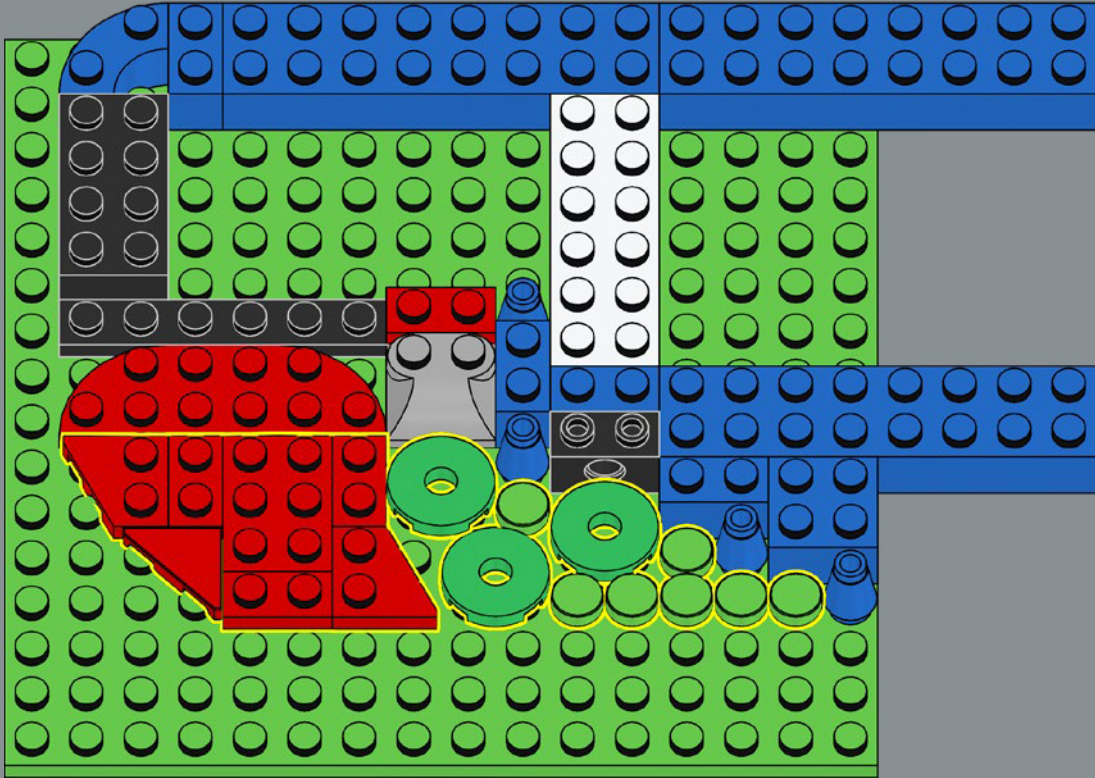

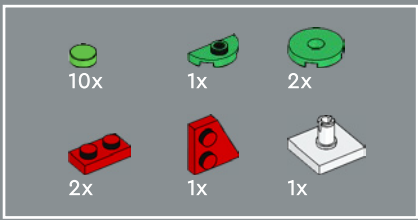

60

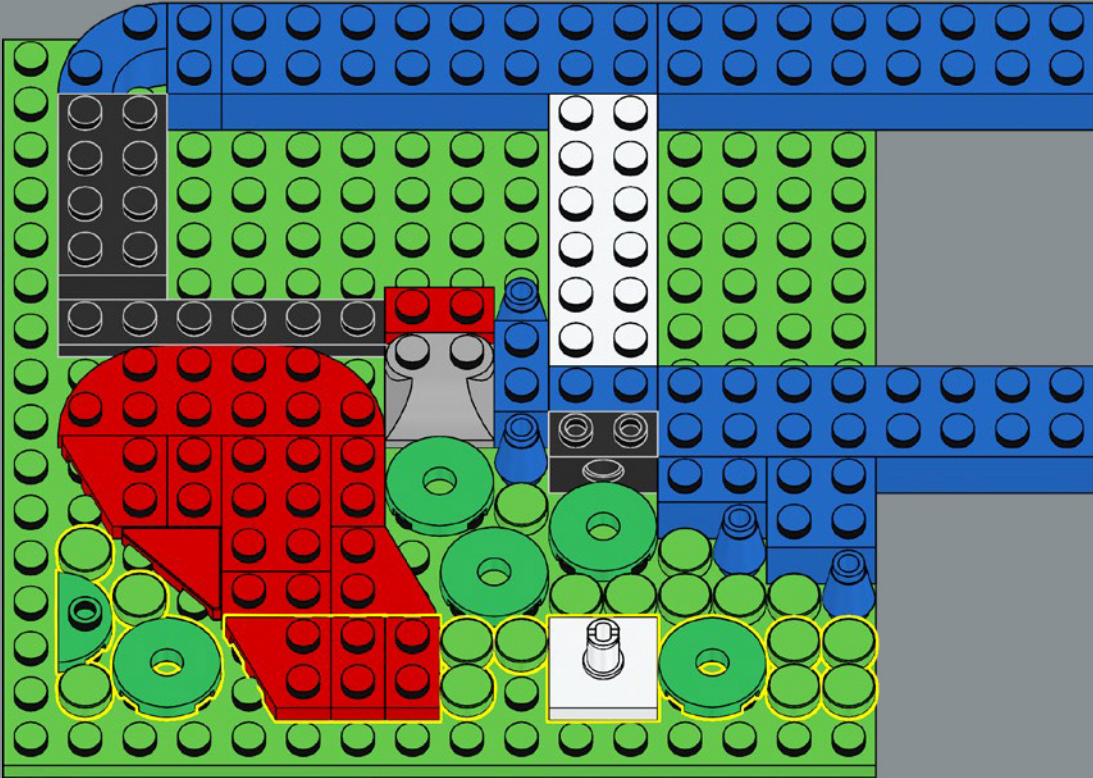

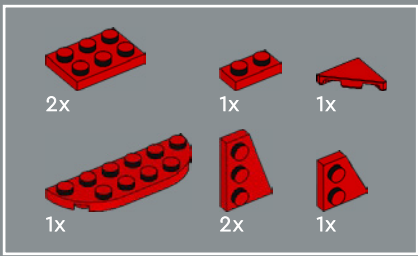

61

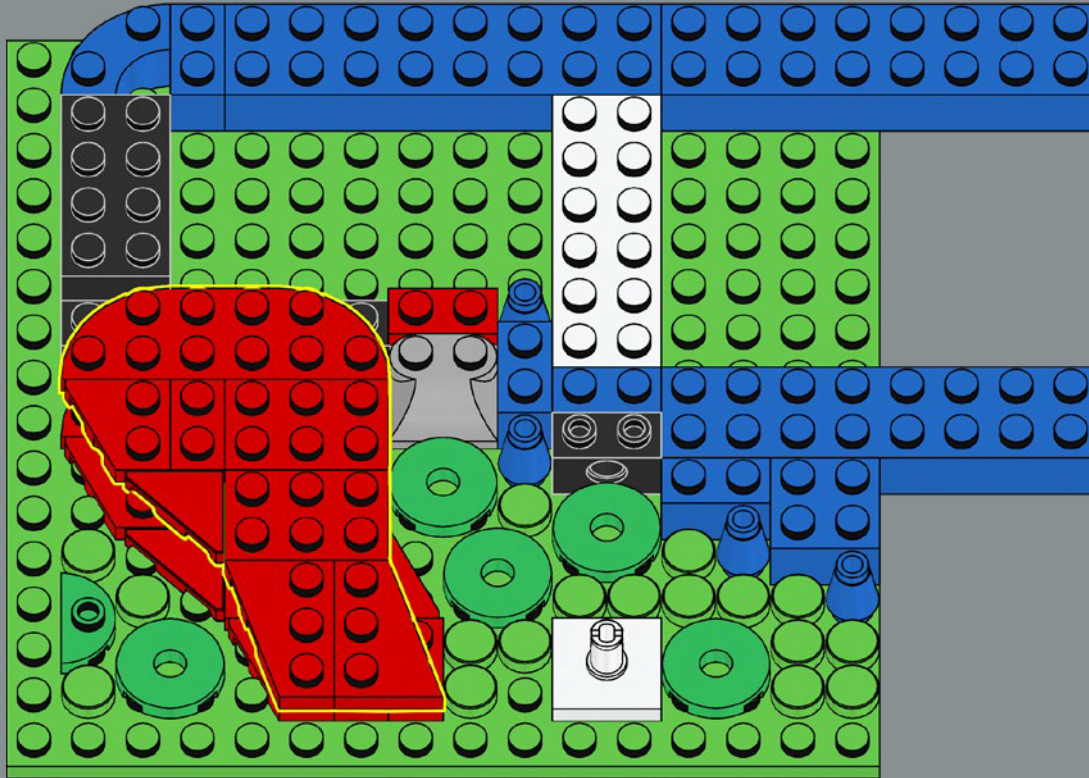

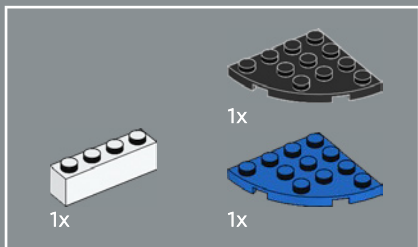

62

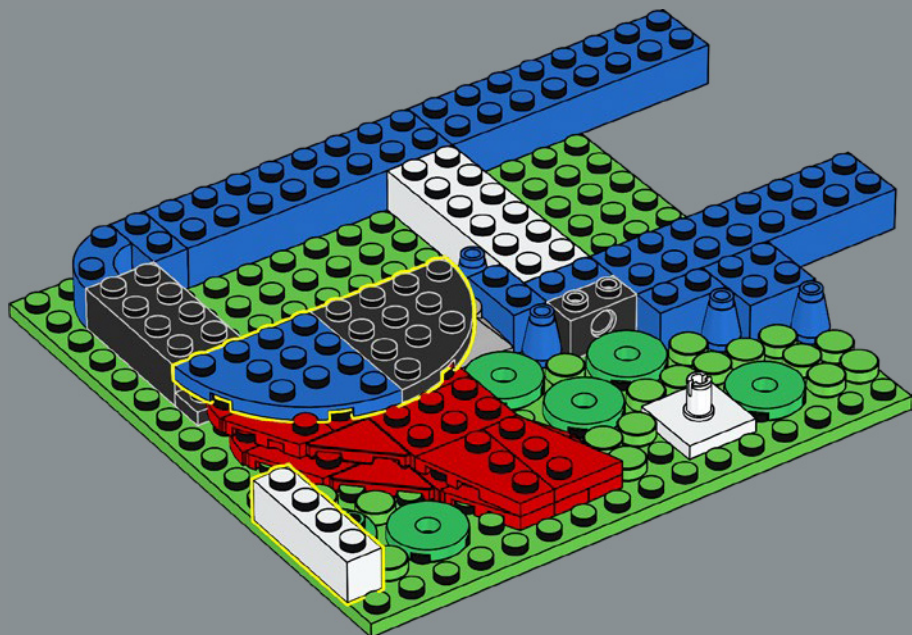

63

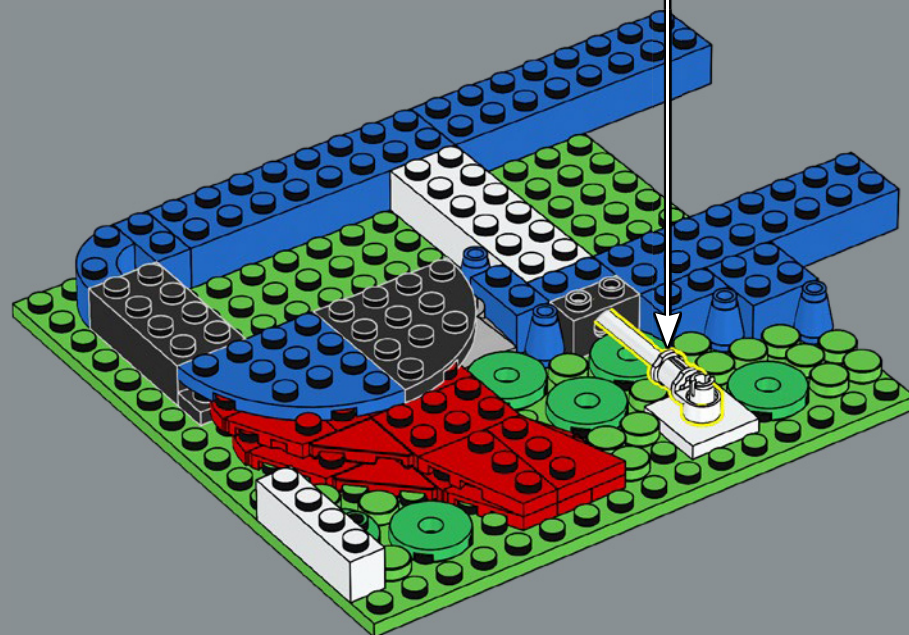
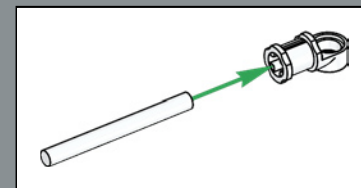



64

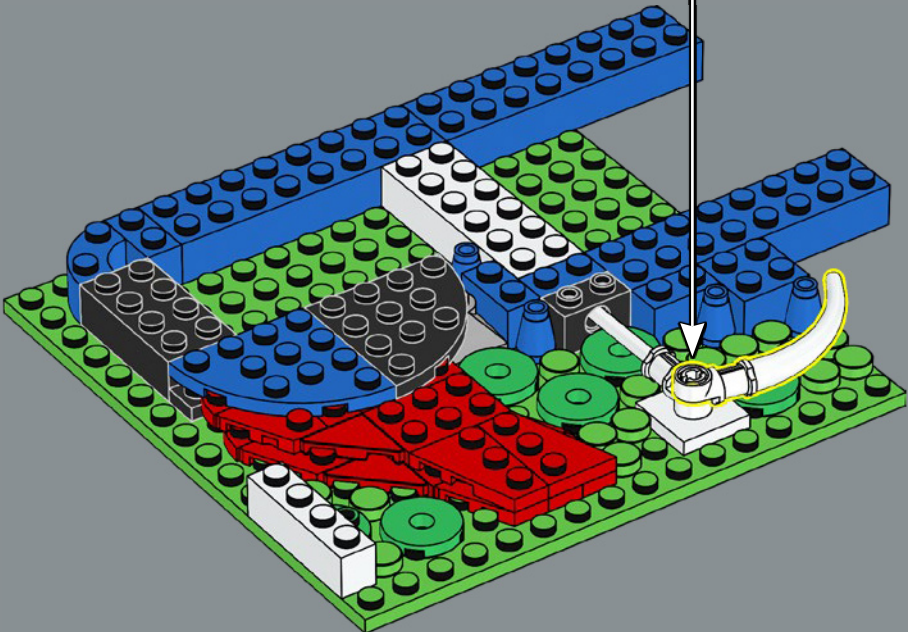
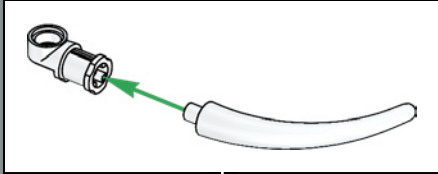

65

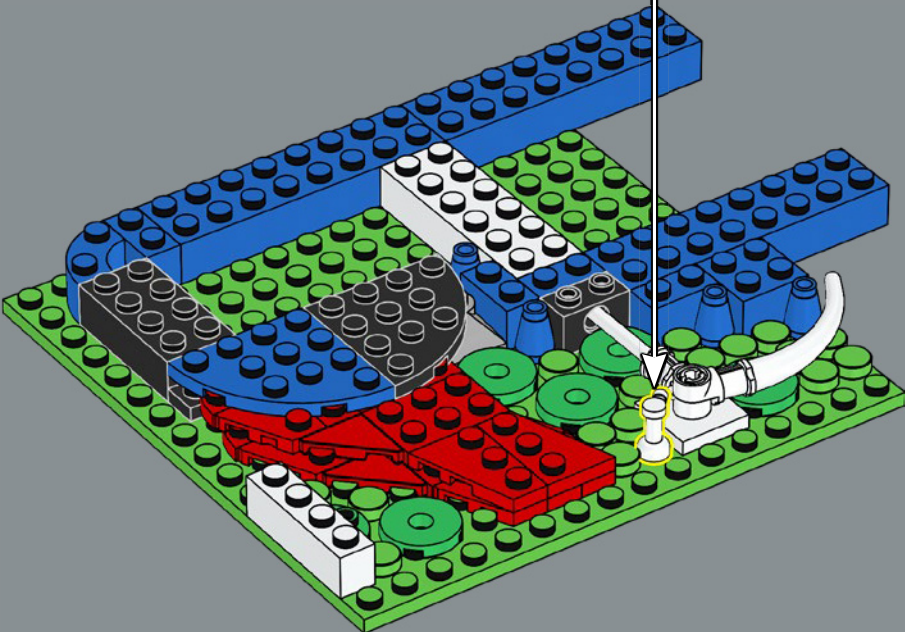



66

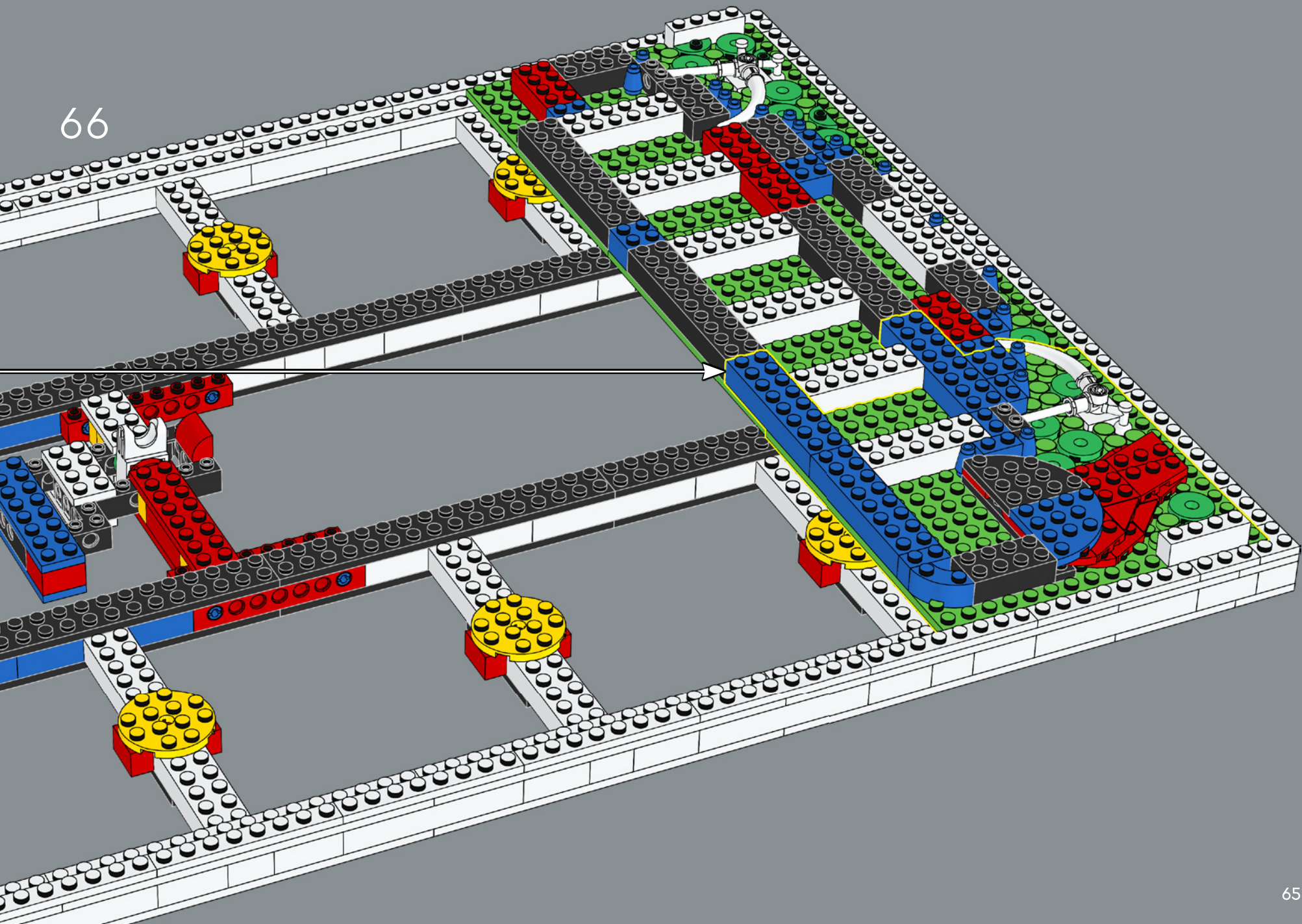

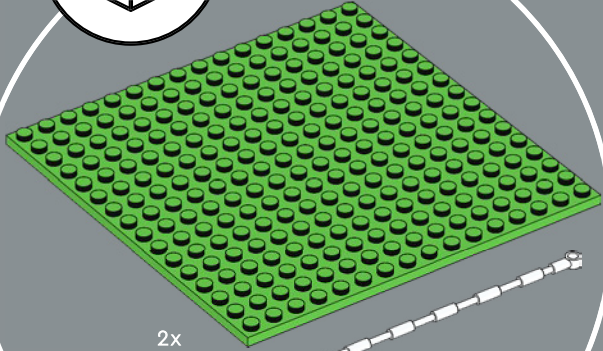
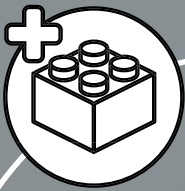

2x

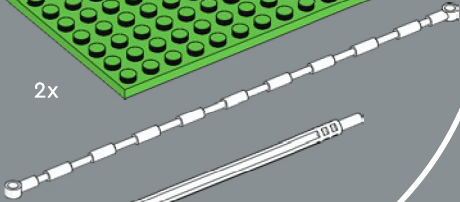

1x

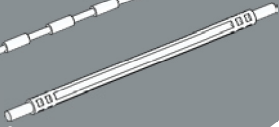

2x

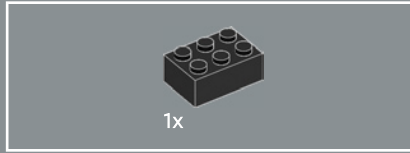
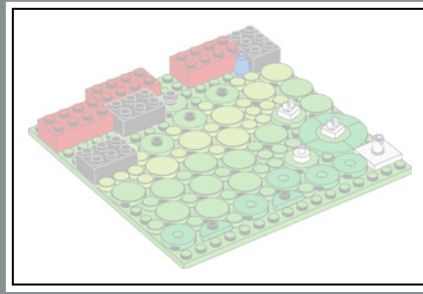

1x

67

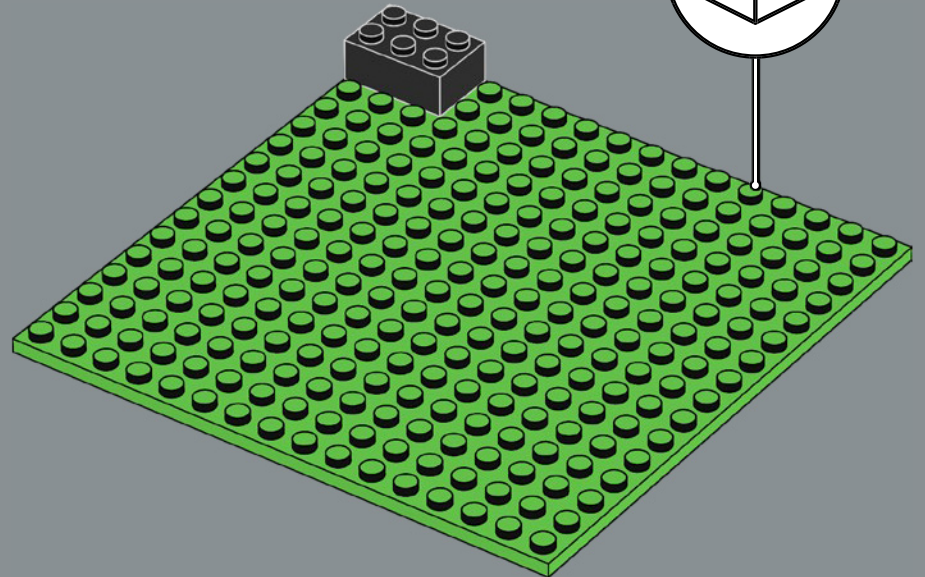
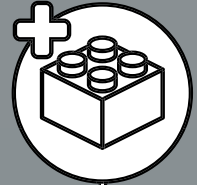

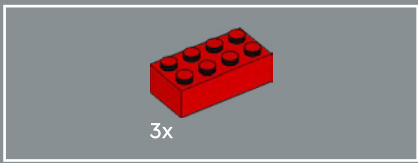

68

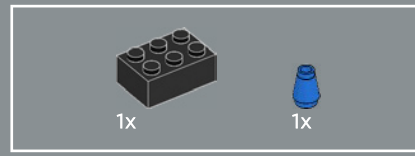
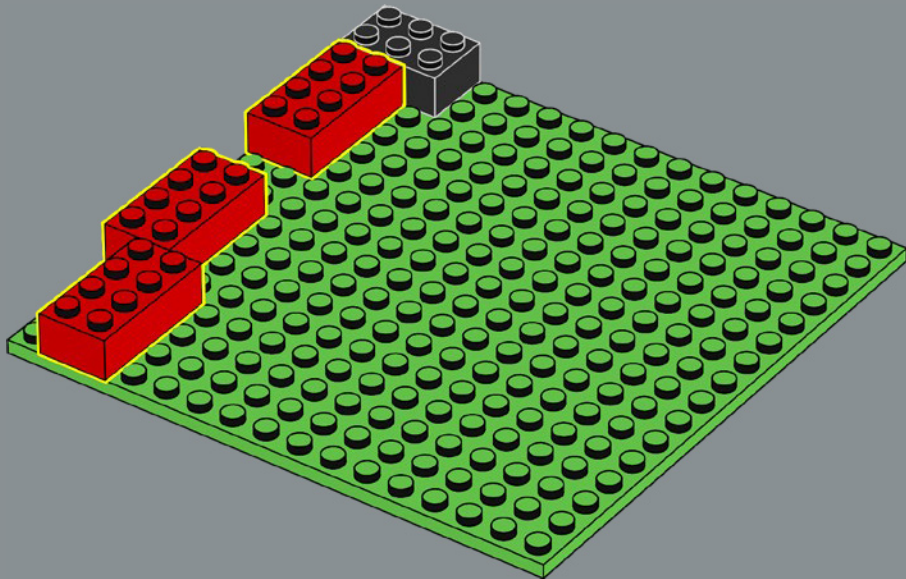

69

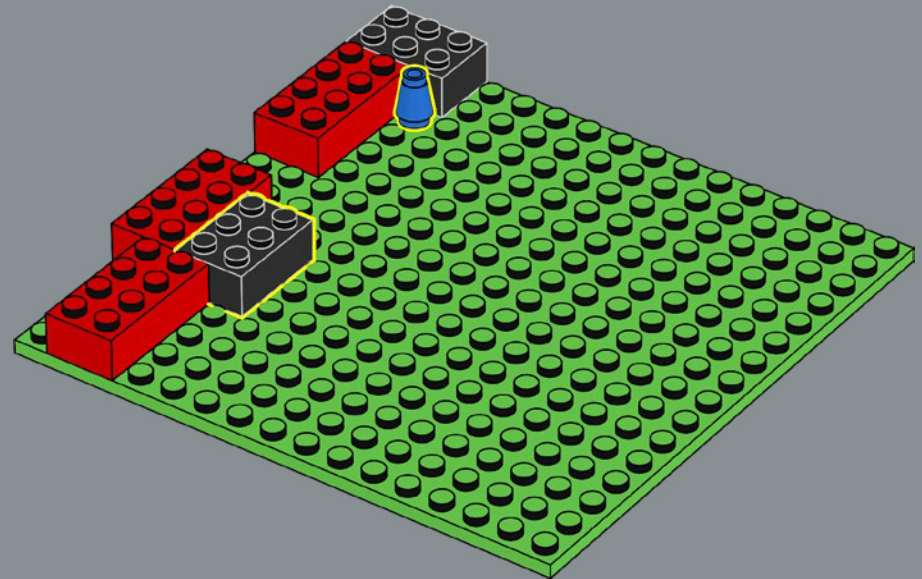



70

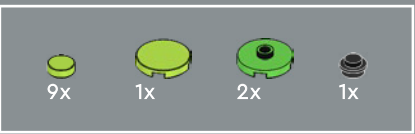
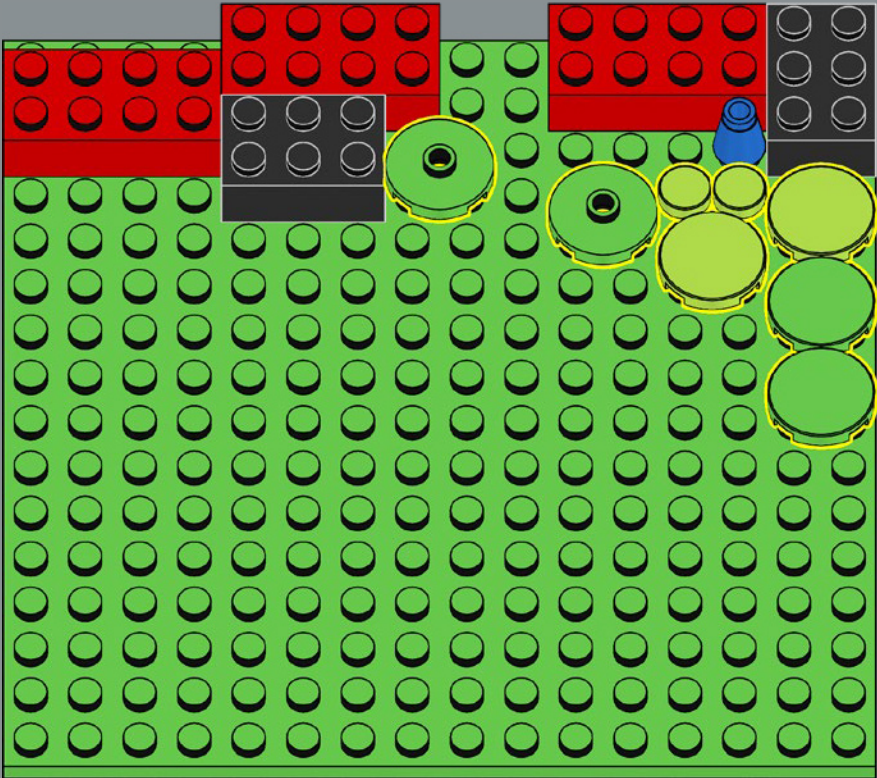

71

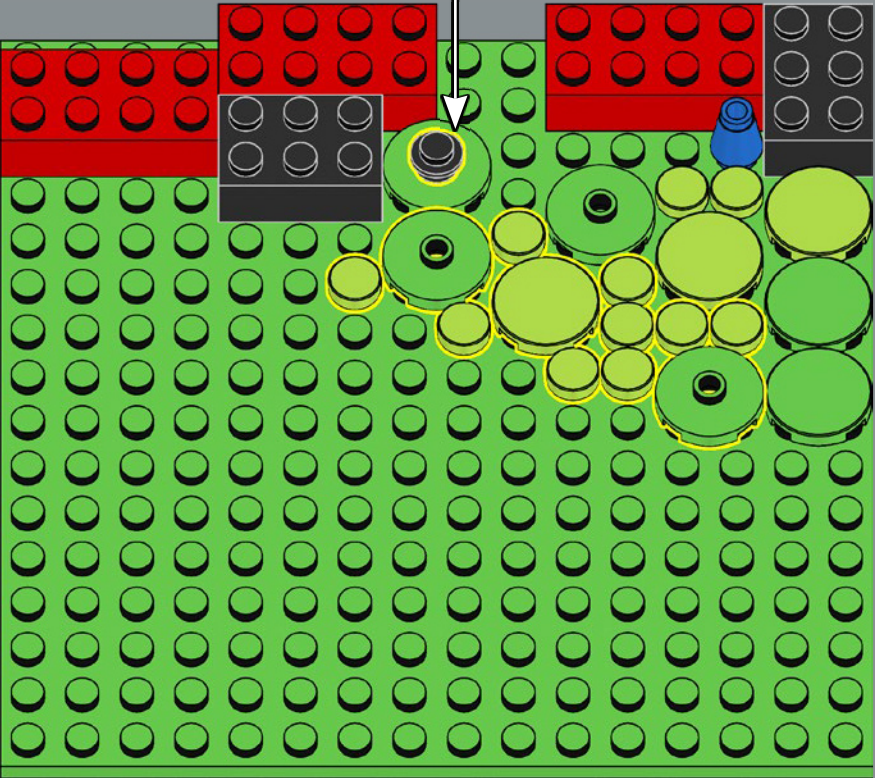

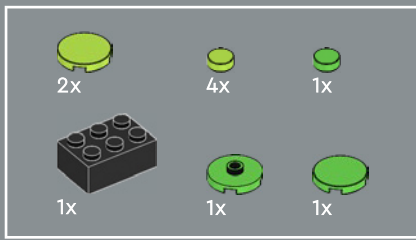

72

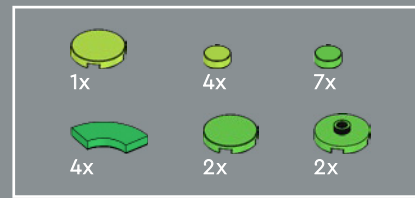
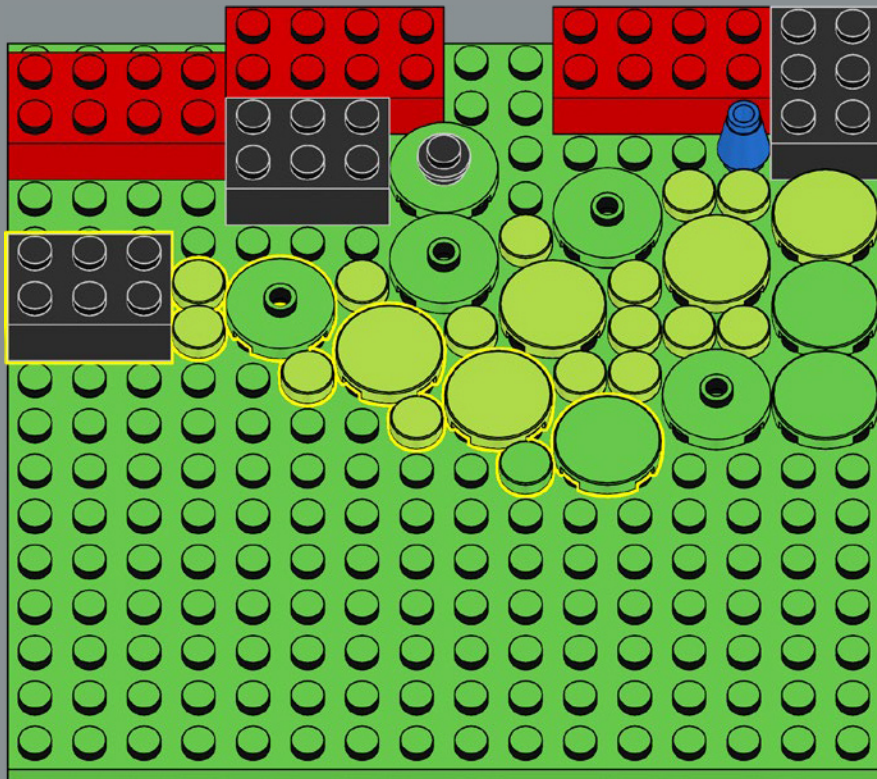

73

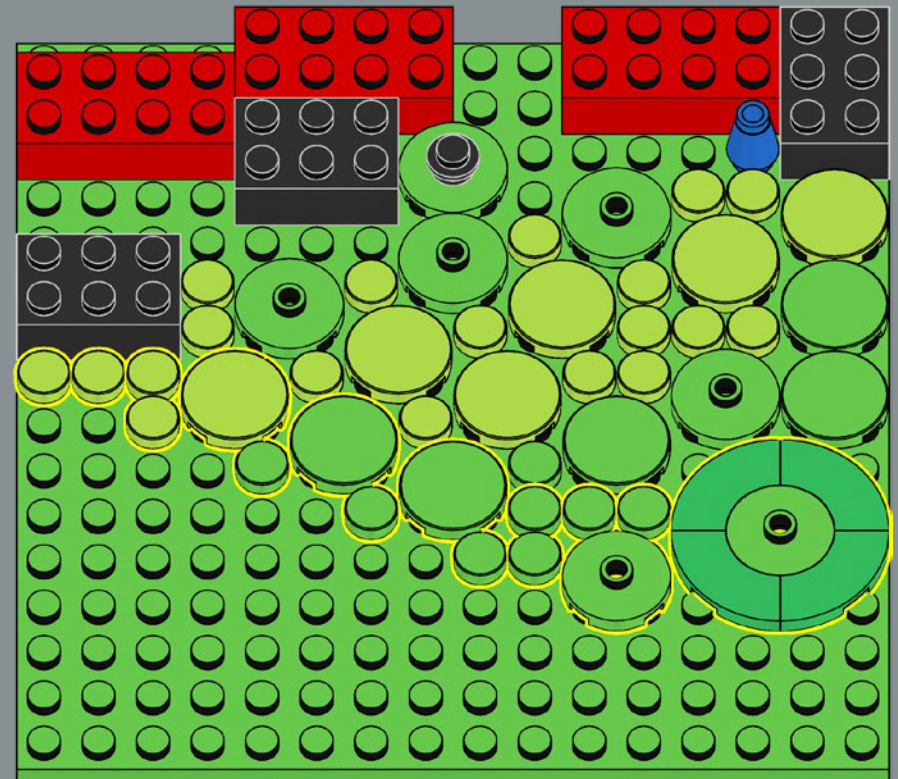

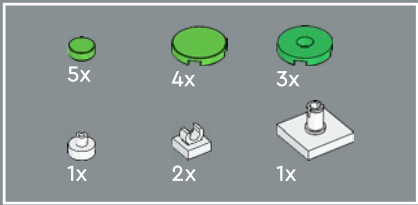

74

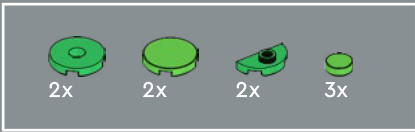
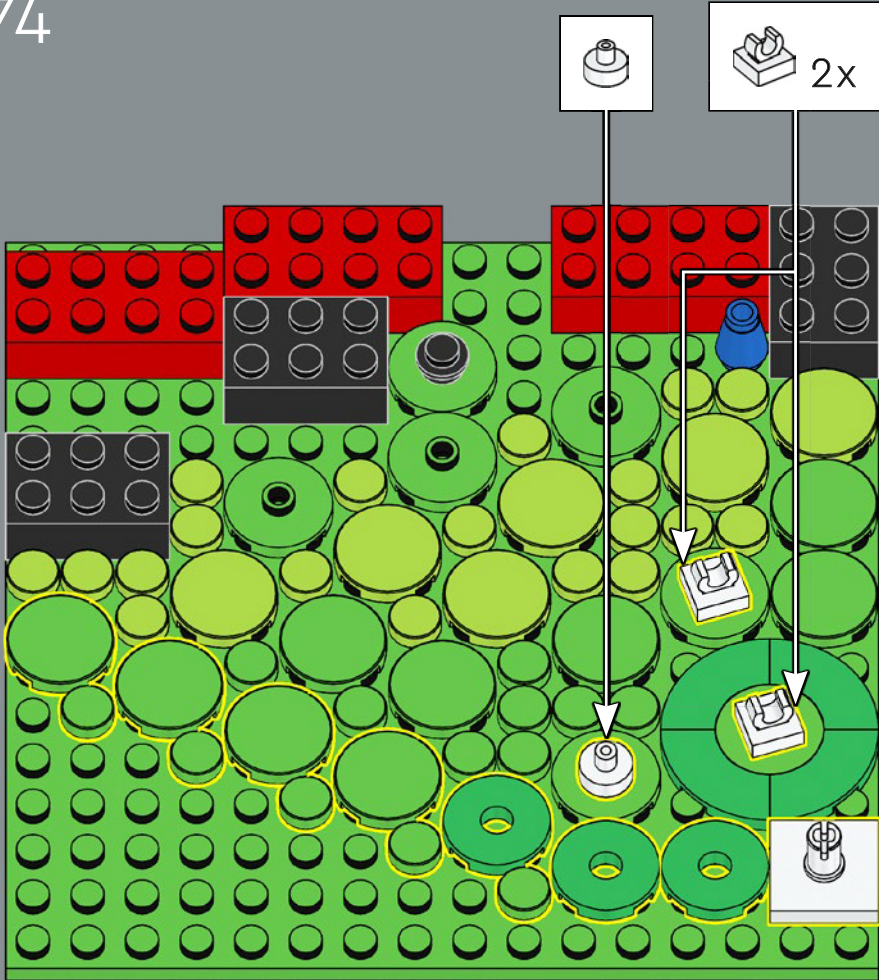

75

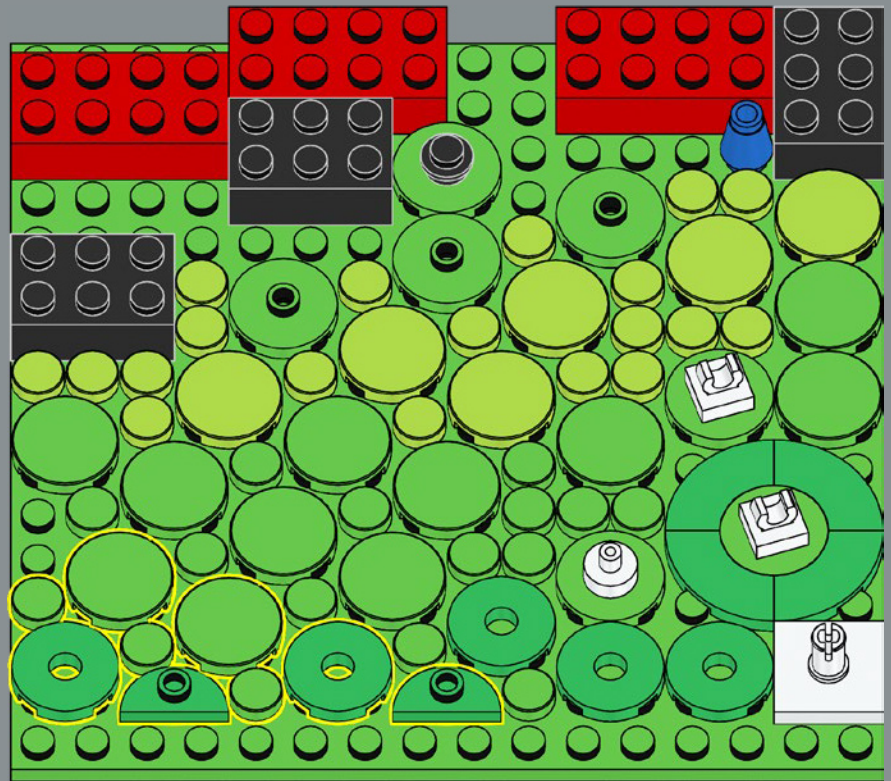

76

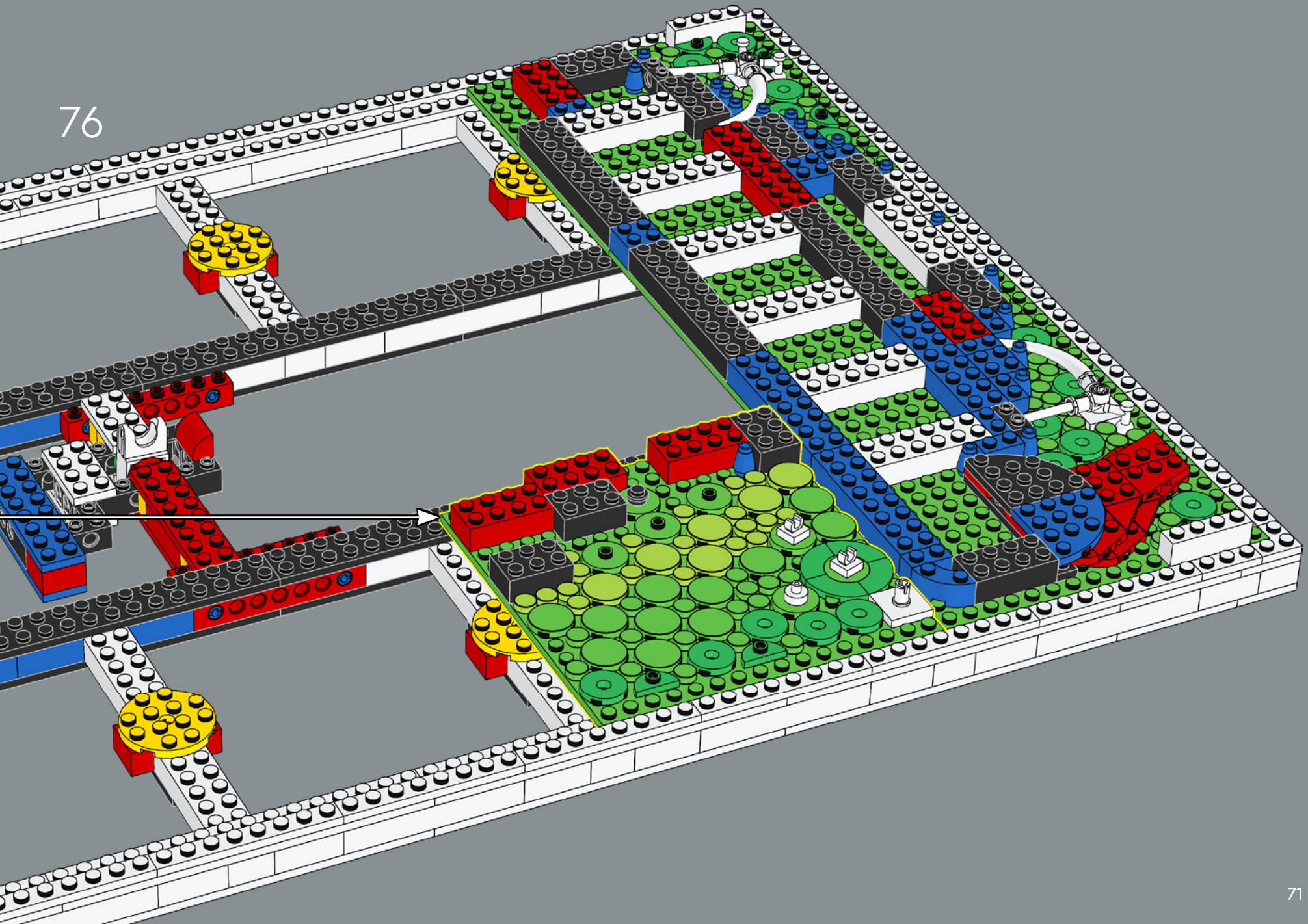

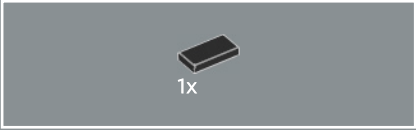
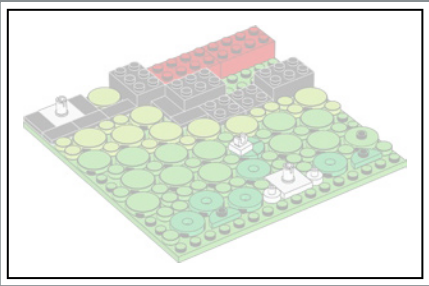

77

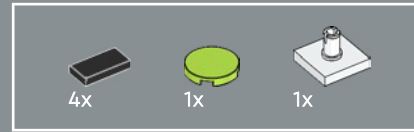
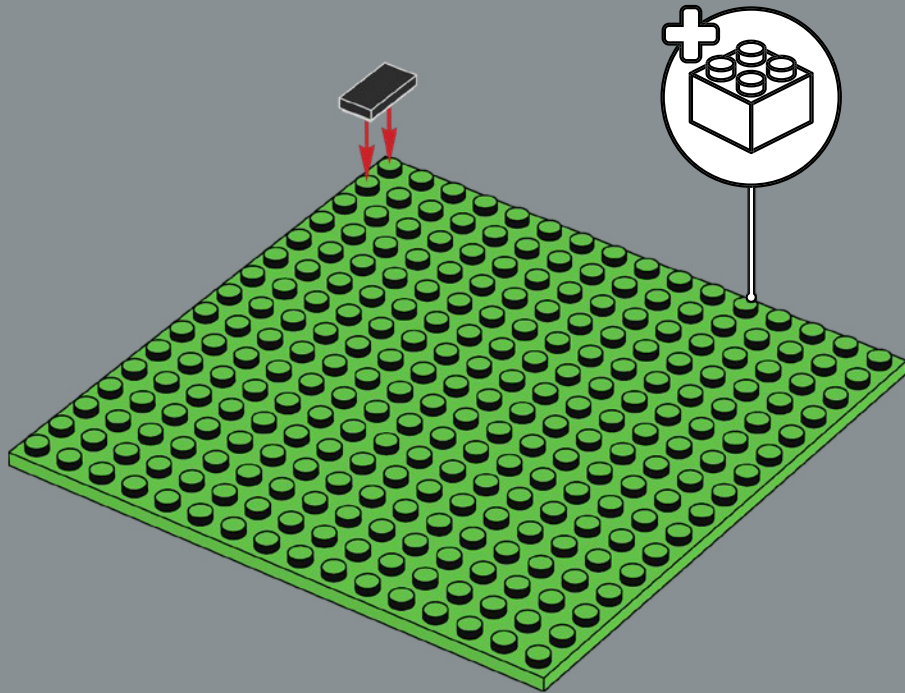

78

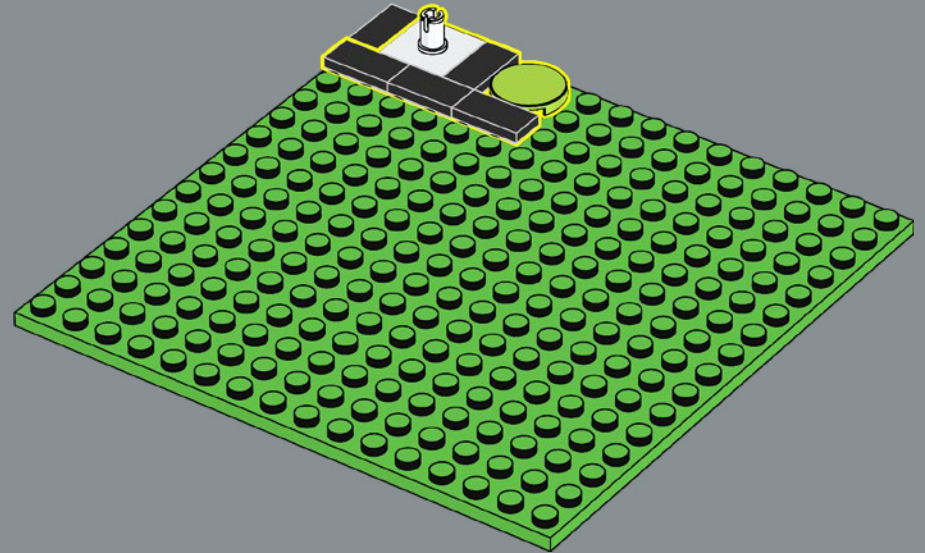



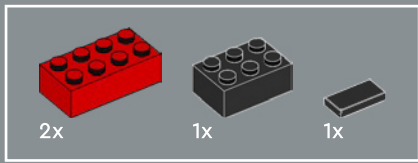

79

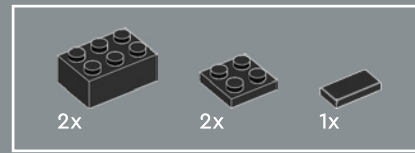
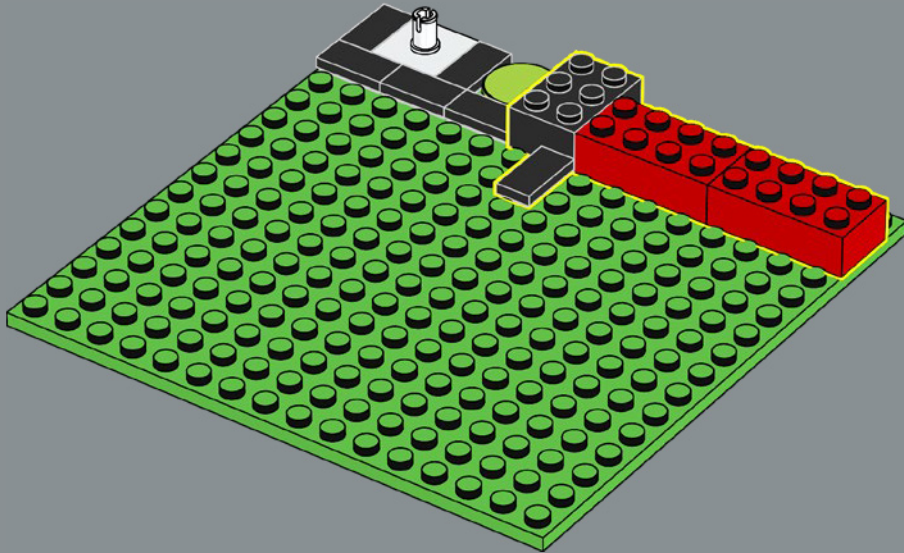

80

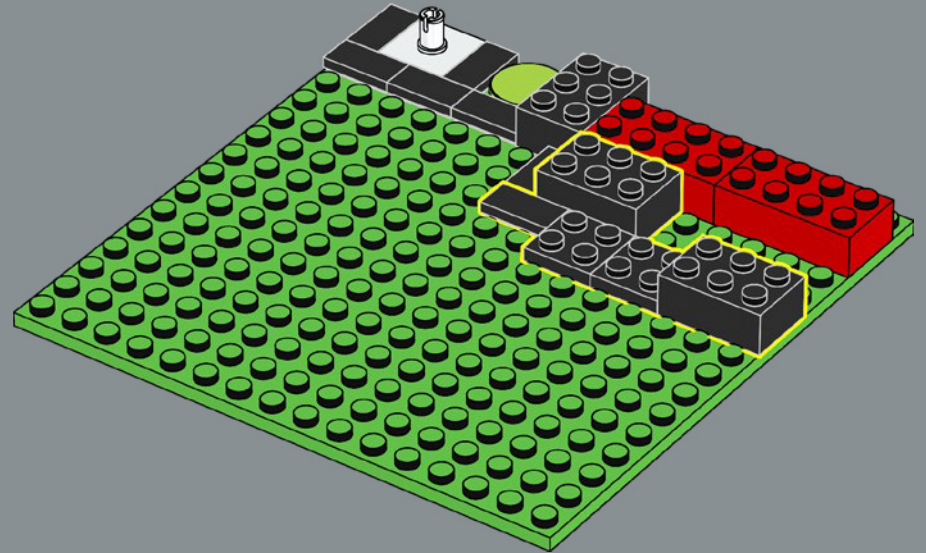

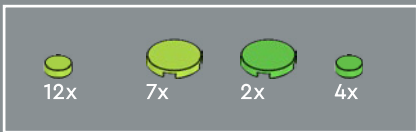

81

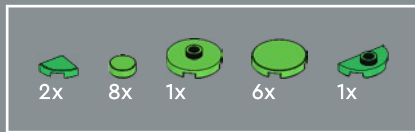
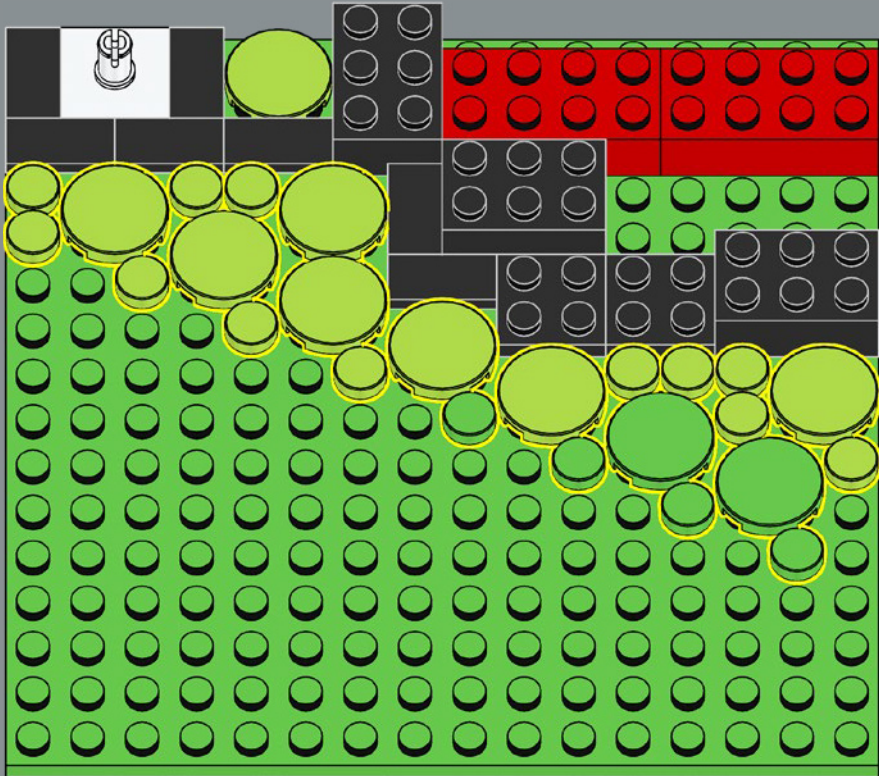

82

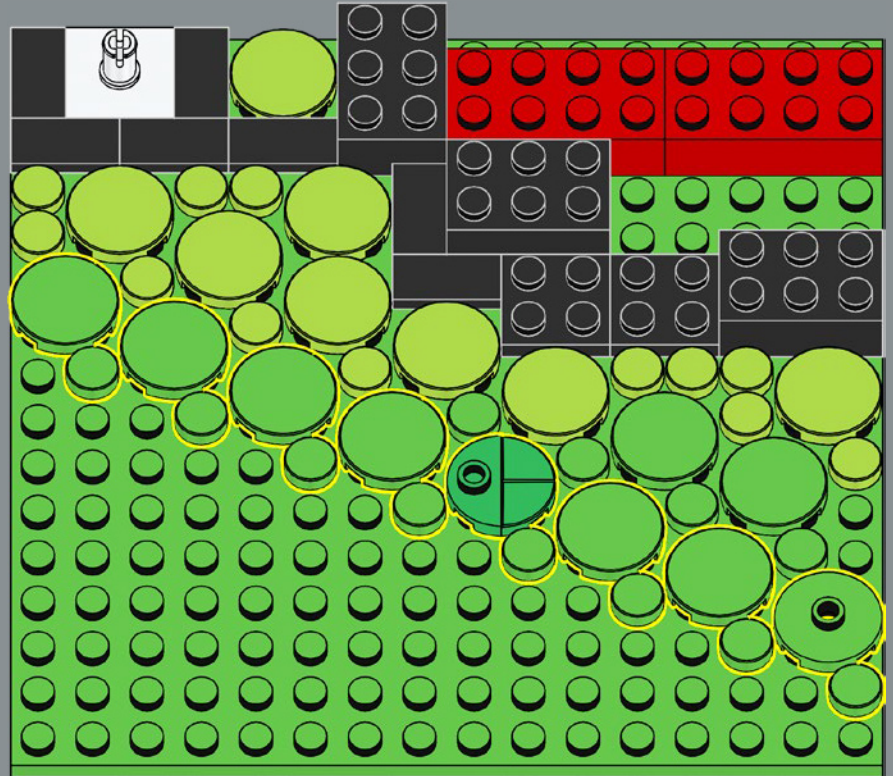

Sometimes applications of colors don't quite align in print, causing colors to bleed into the background. This building technique plays homage to this effect, and the use of the **Ben Day printing process**.

Parfois, les applications de couleurs ne sont pas tout à fait alignées à l'impression, ce qui entraîne un débordement des couleurs sur l'arrière-plan. Cette technique de construction rend hommage à cet effet et à l'utilisation du **procédé d'impression Ben Day**.

A veces, los colores no quedan perfectamente alineados en la impresión, lo que provoca que lleguen al fondo. Esta técnica de construcción rinde un homenaje a este efecto y al uso del **proceso de impresión Ben-Day**.

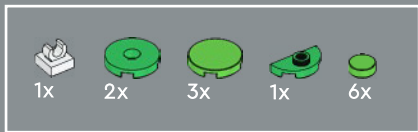

83

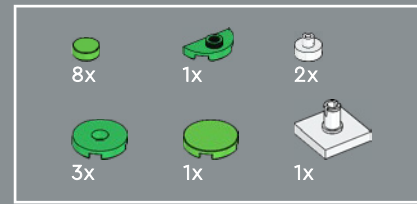
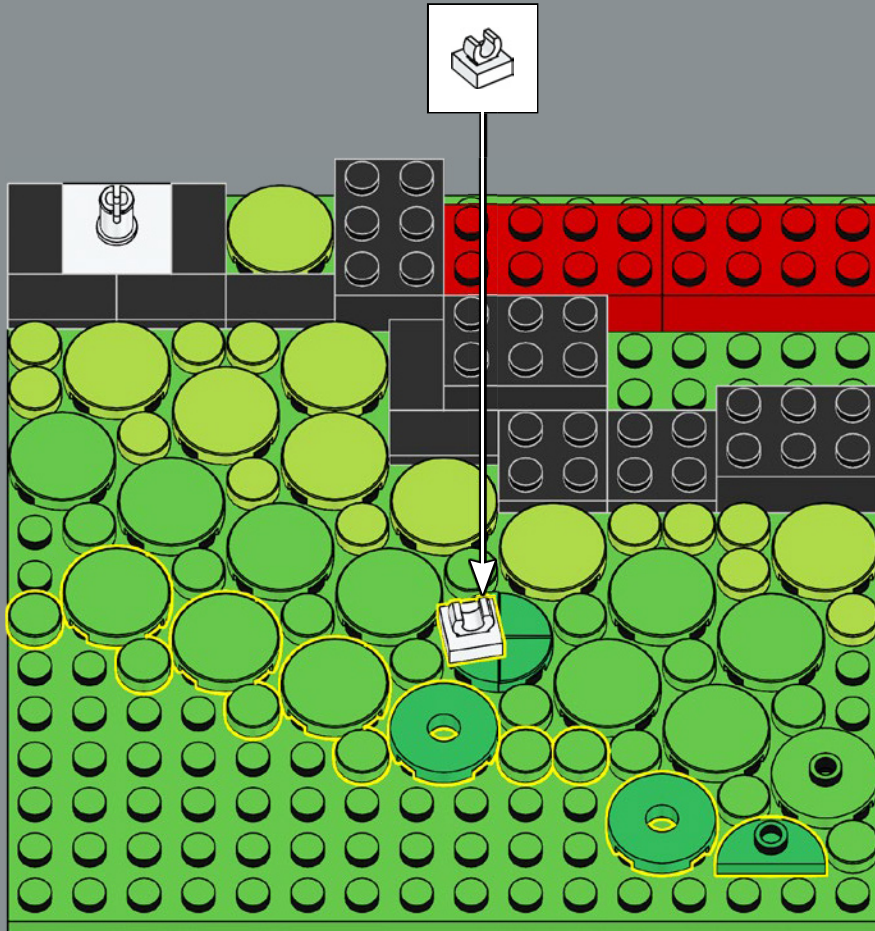

84

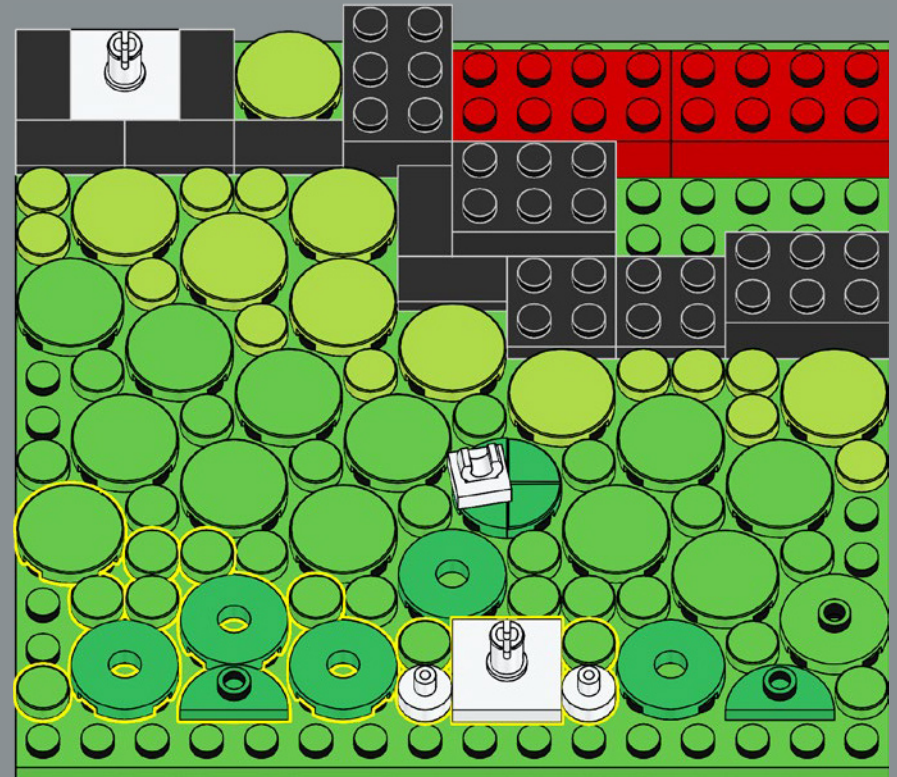

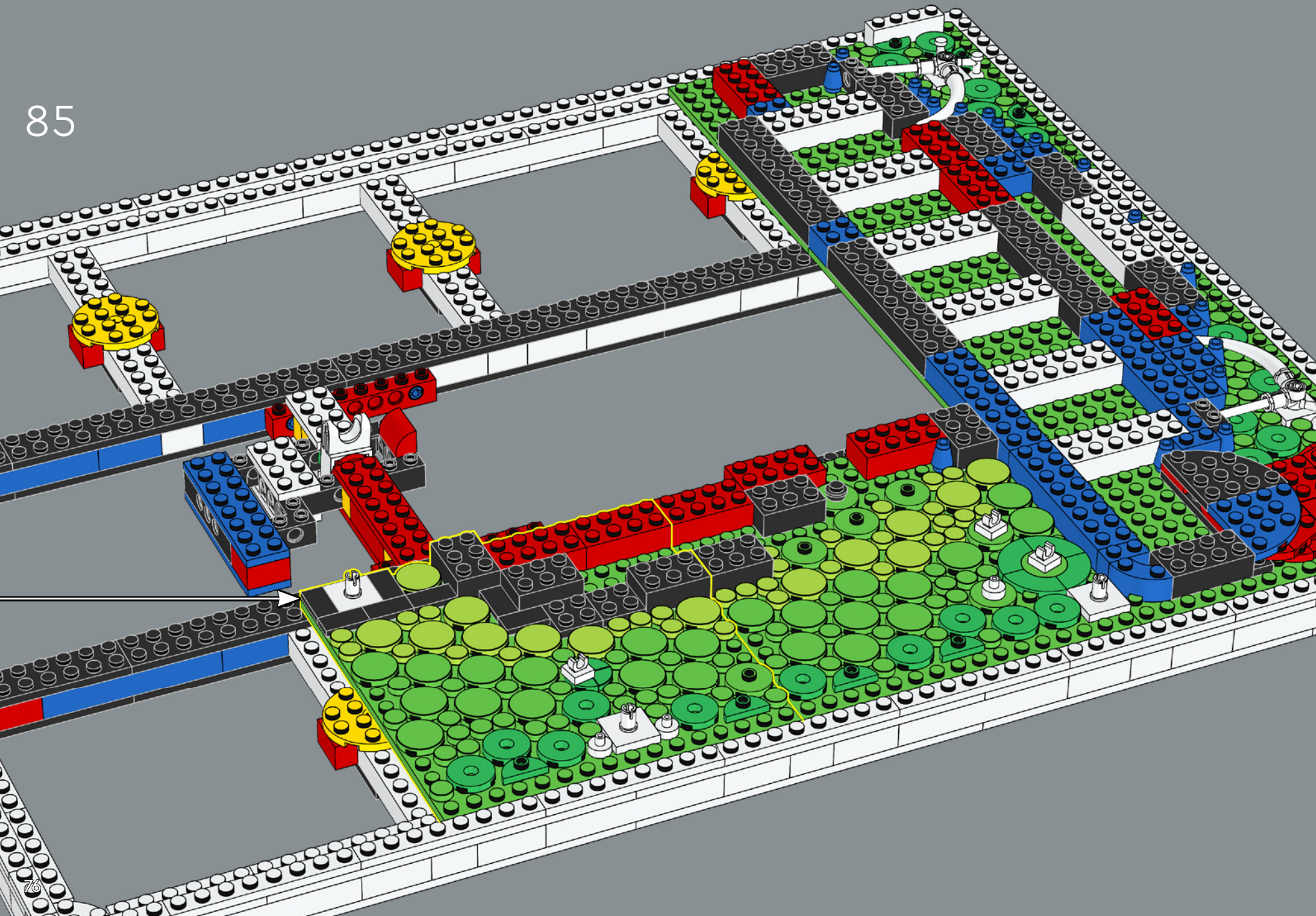

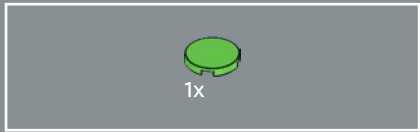

86

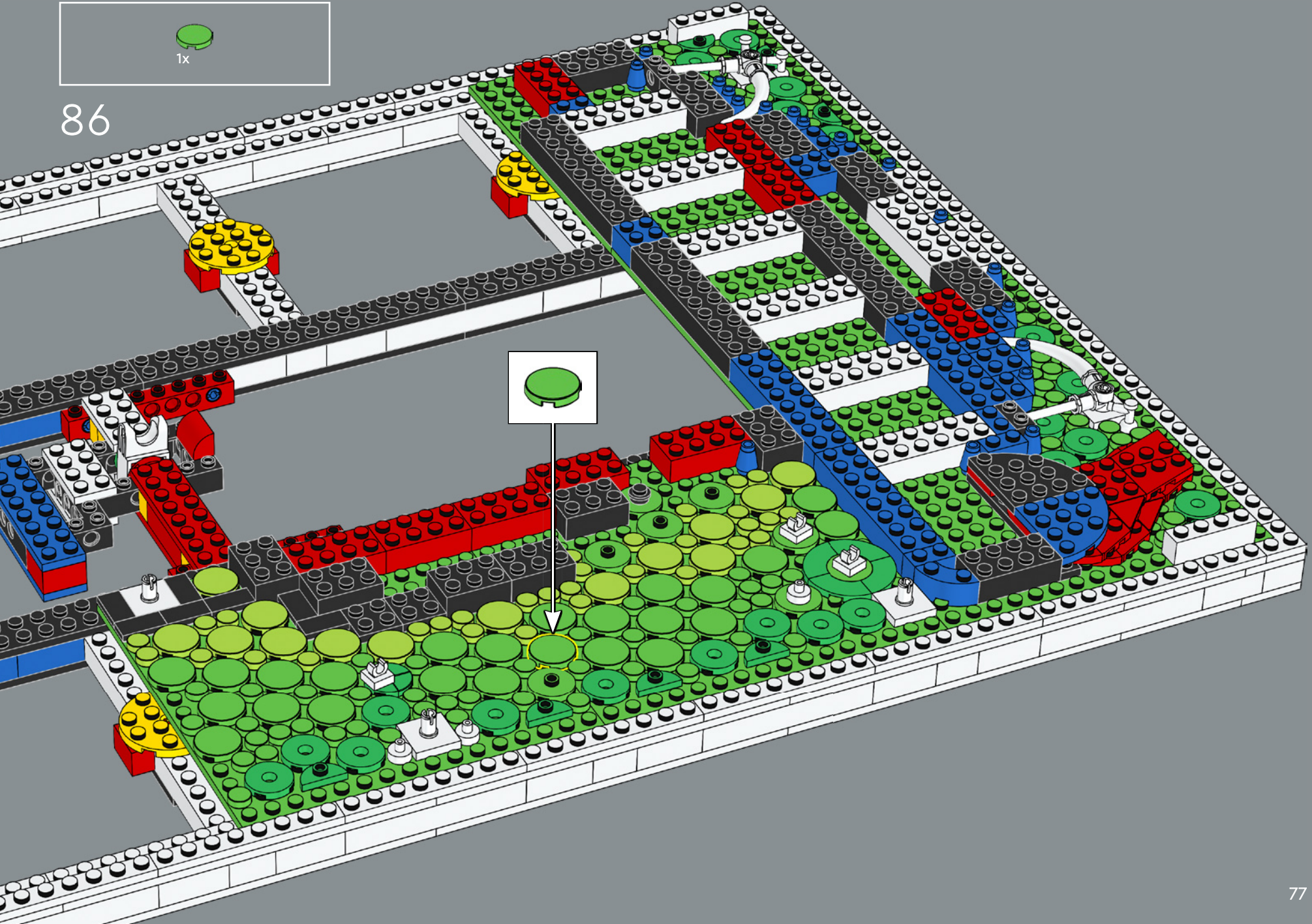

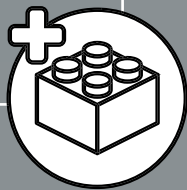
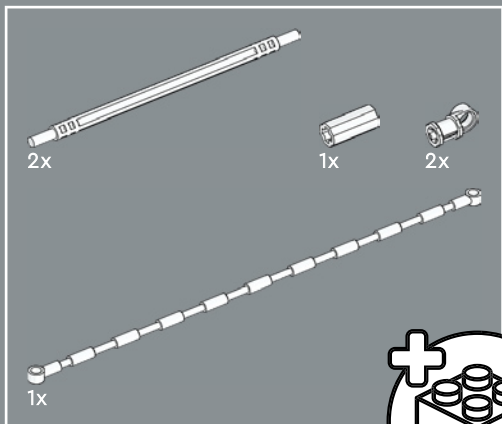

87

Spider-Man has spent long hours practicing the operation of his web...  
The terrific teenager can now use it in many different ways! - Thwip!

Spider-Man a passé de longues heures à s'entraîner au maniement  
de sa toile... L'adolescent sensationnel peut maintenant l'utiliser de  
nombreuses façons différentes : Zzzzip !

Spider-Man ha pasado largas horas practicando el funcionamiento de  
su telaraña... Y ahora, ¡este sobresaliente adolescente puede utilizarla  
de muchísimas formas! (¡Zzzzip!).

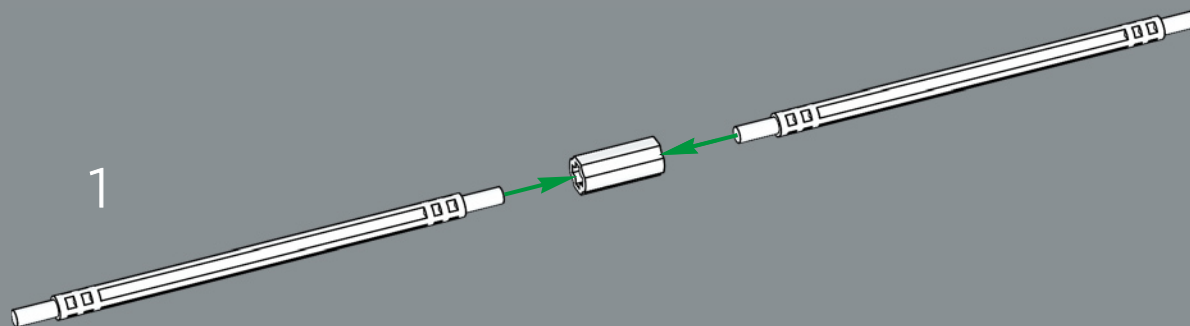

2

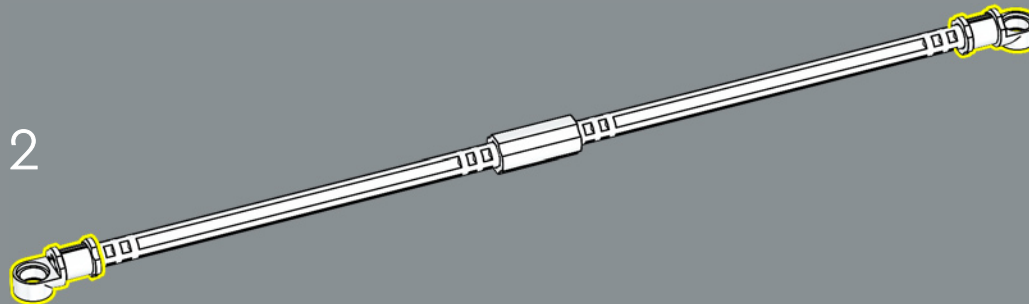

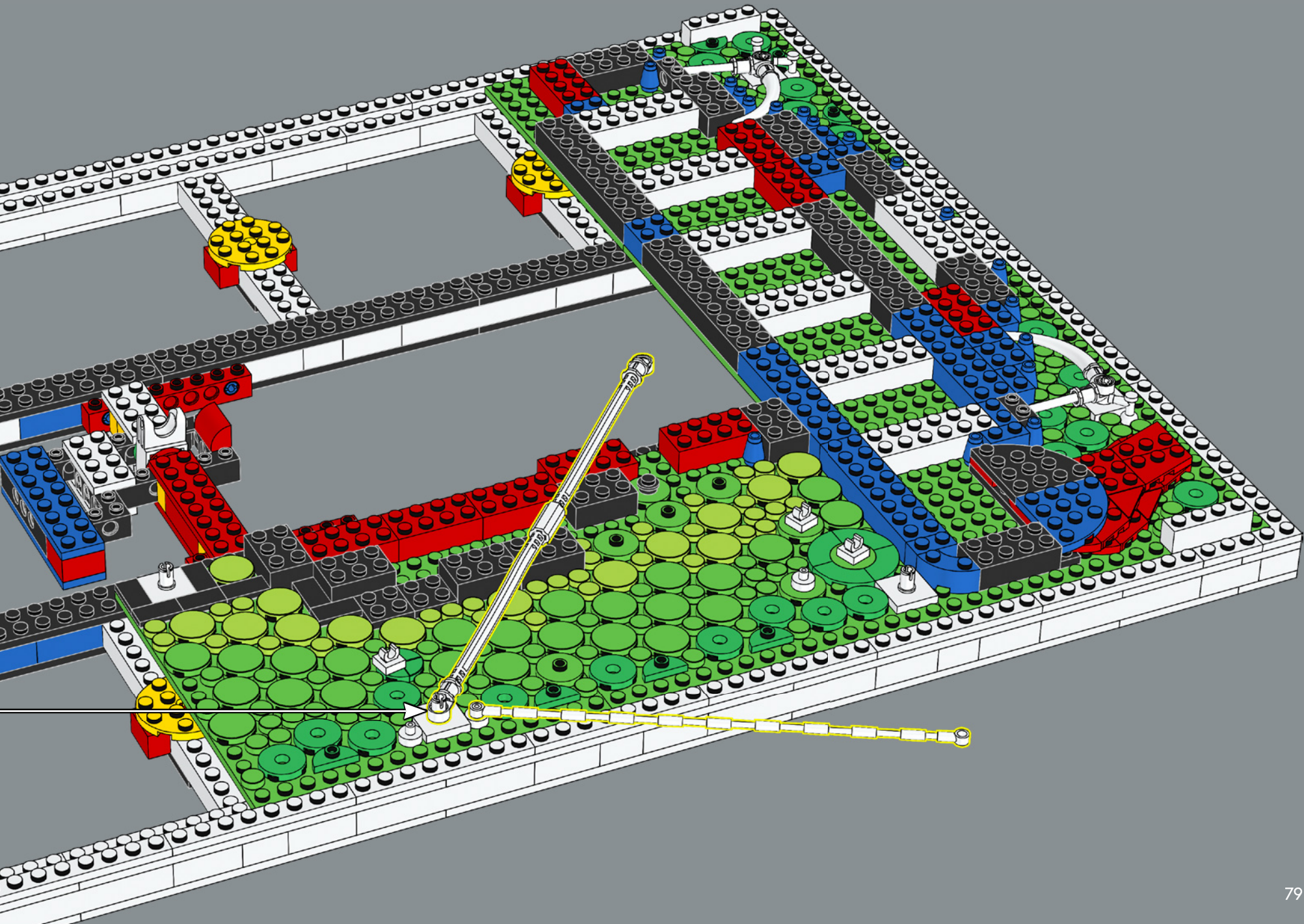

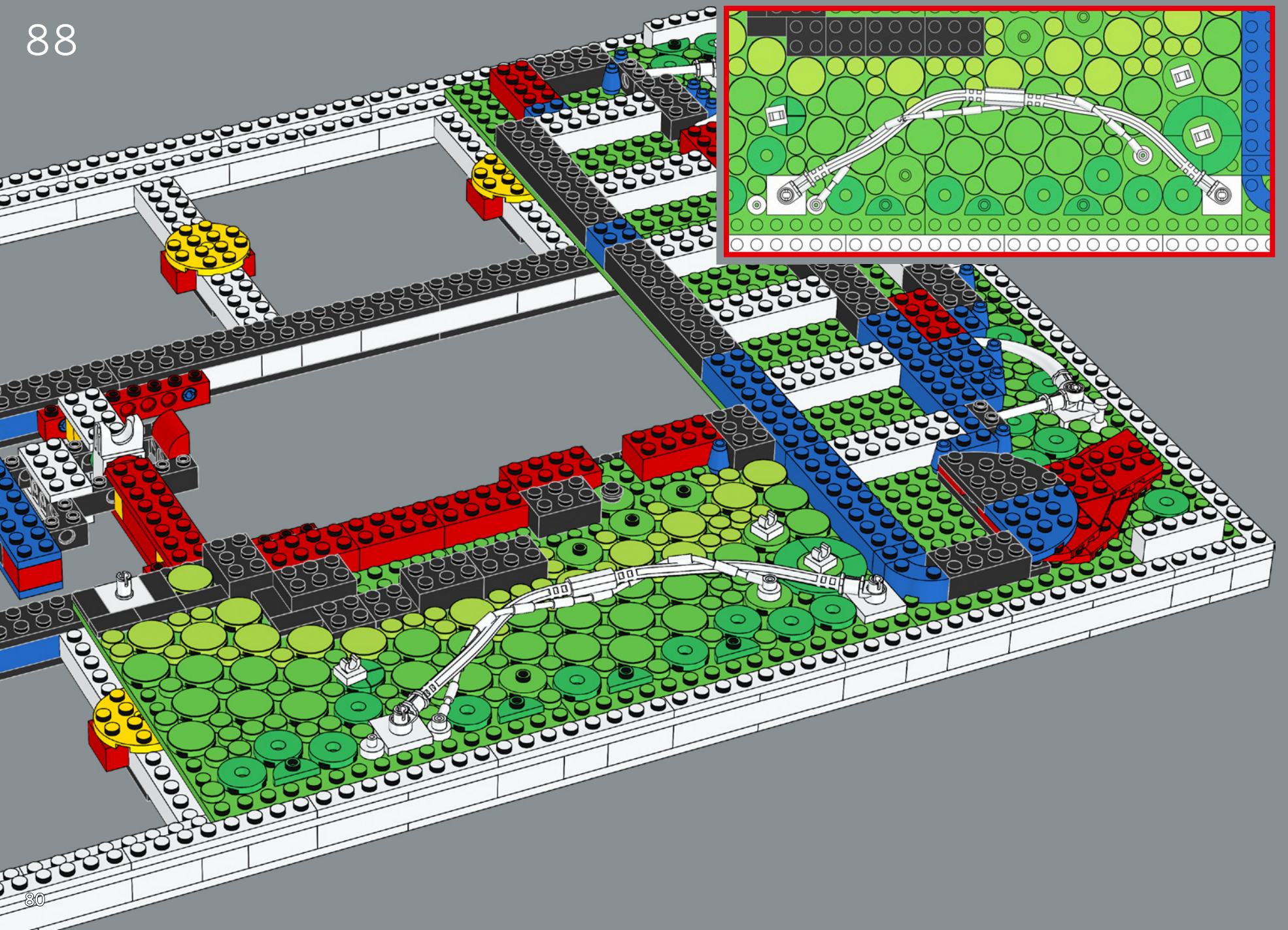



1x  1x 

89

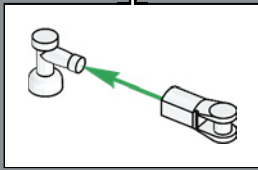
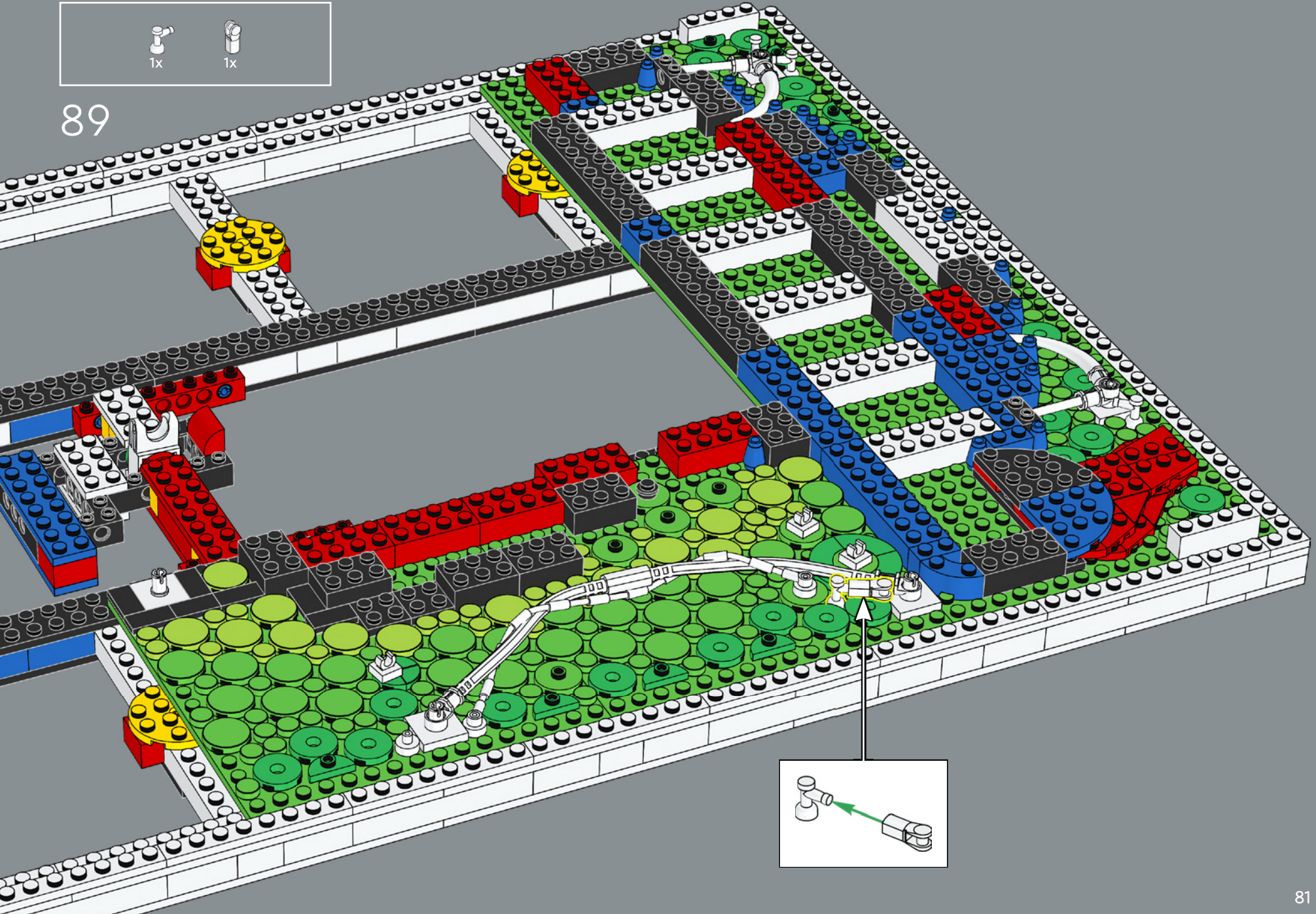

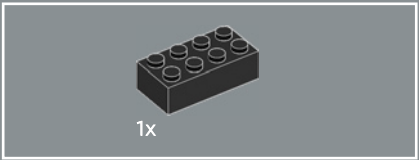
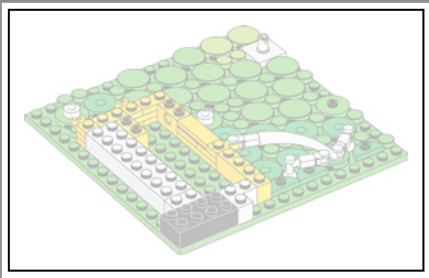
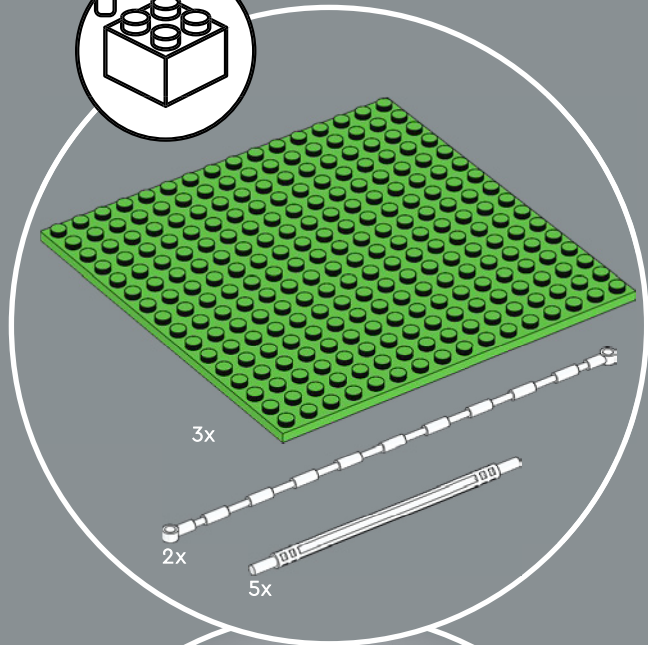
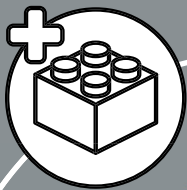

90

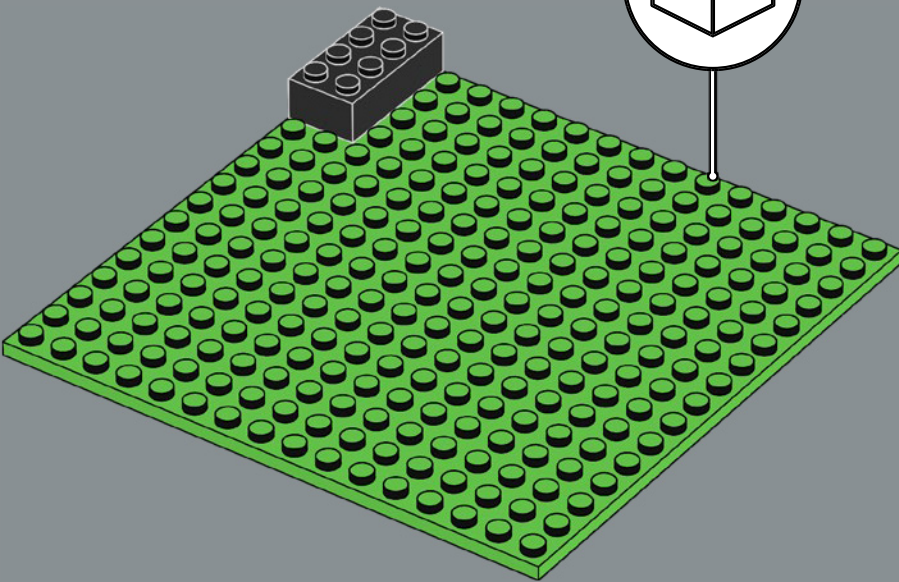
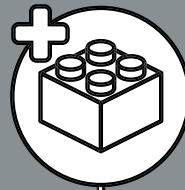

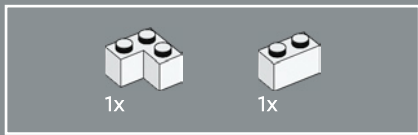

91

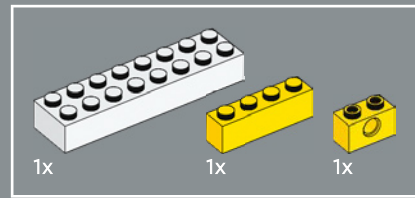
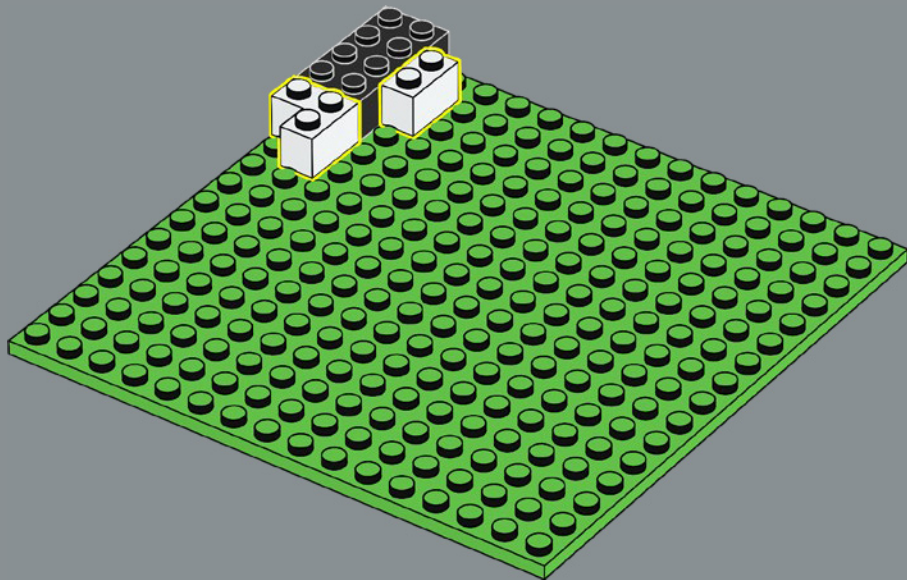

92

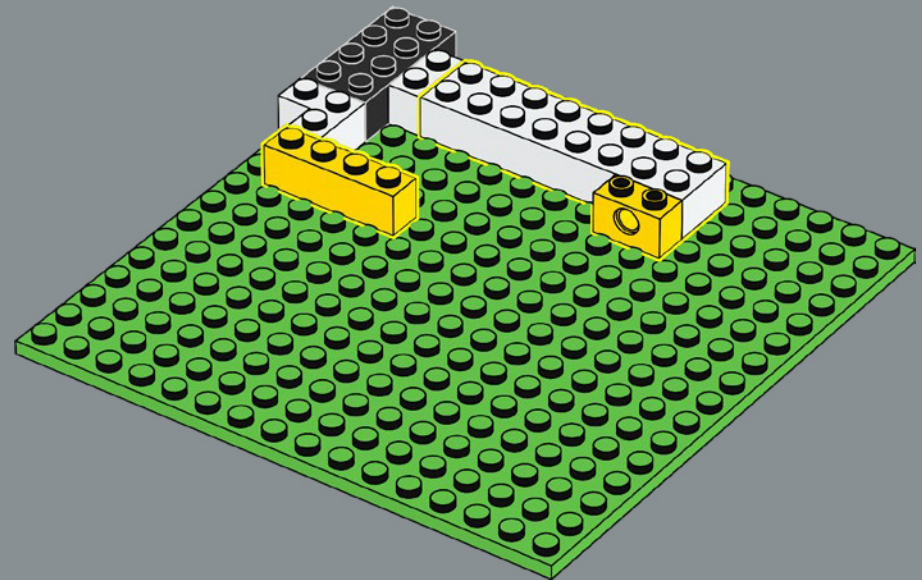

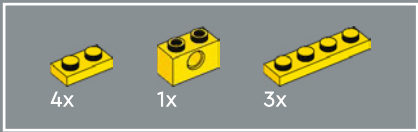

93

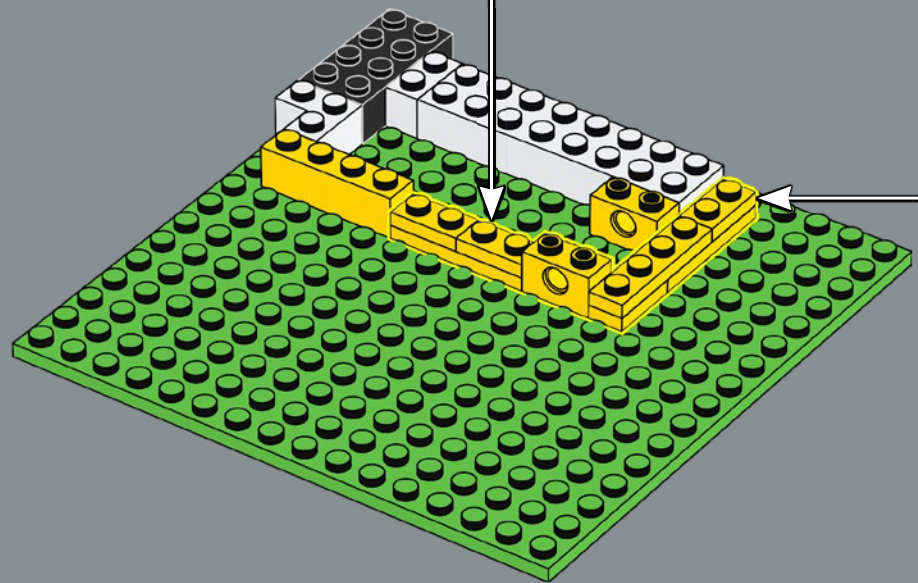
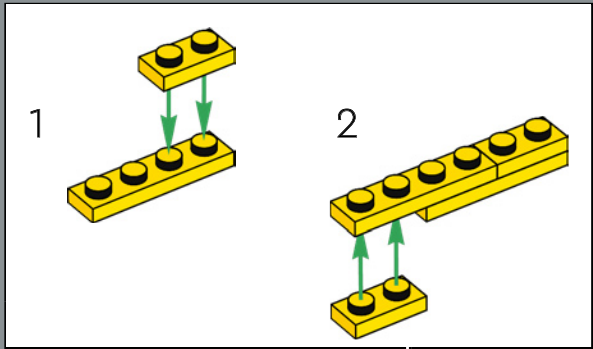
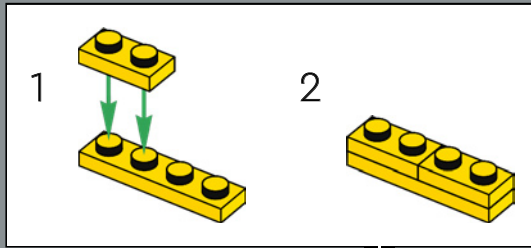

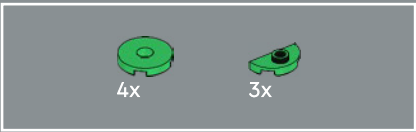

94

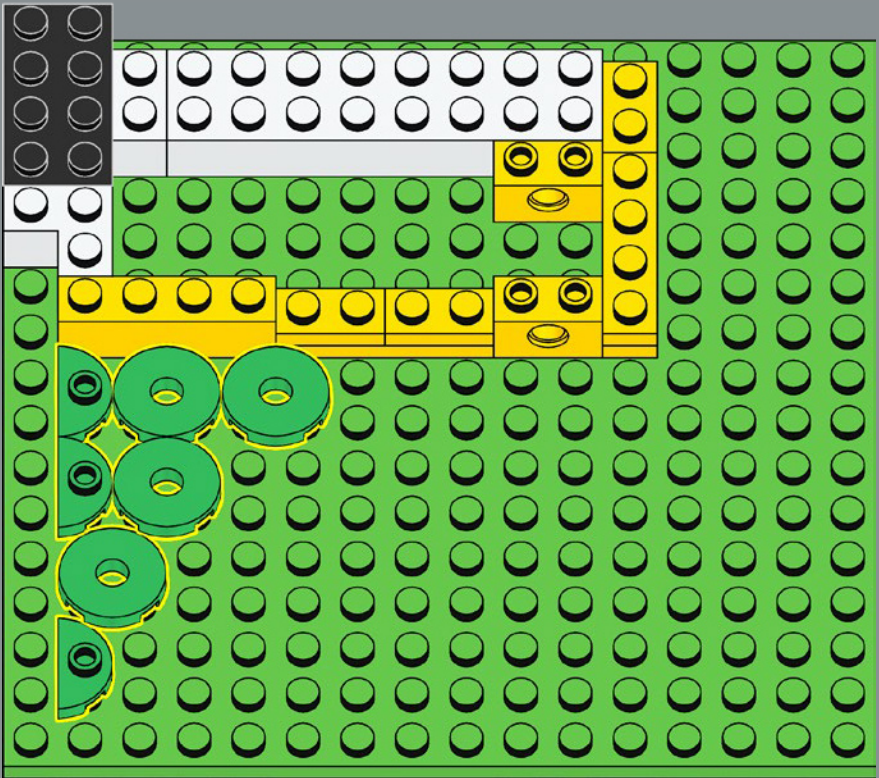

95

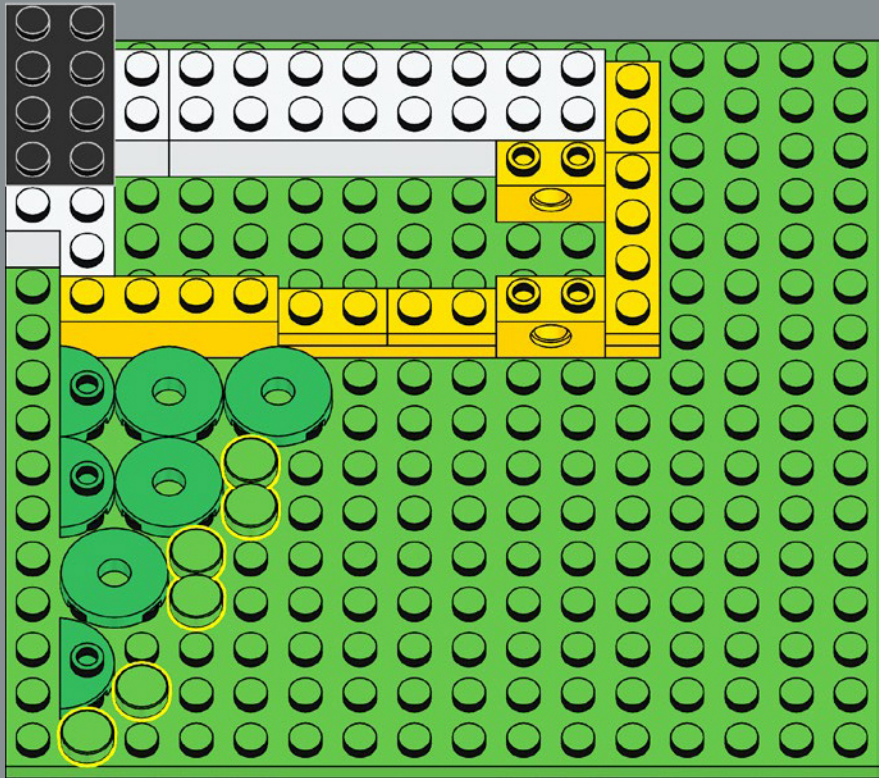

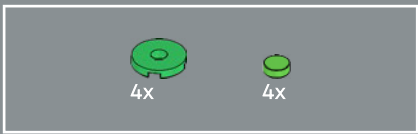

96

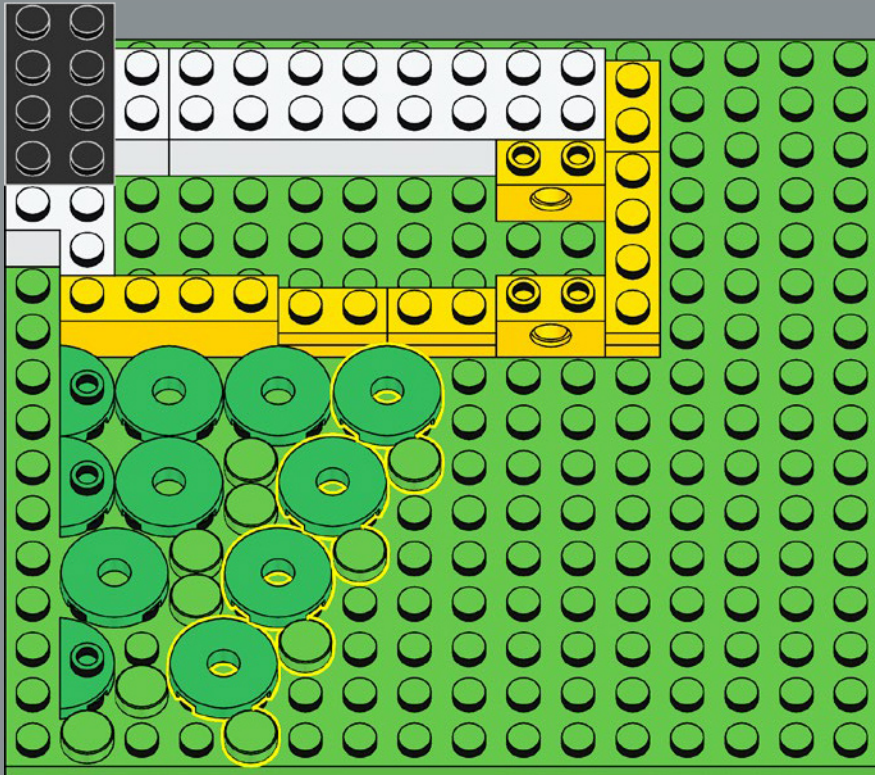

97

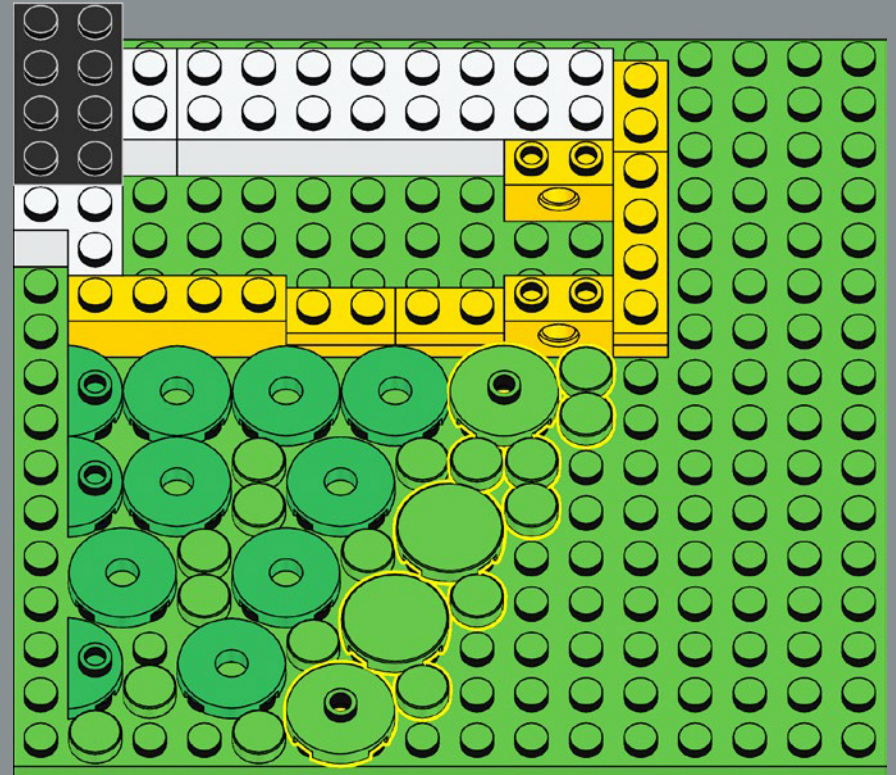

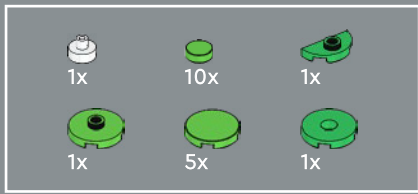

98

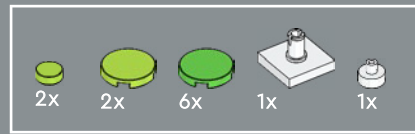
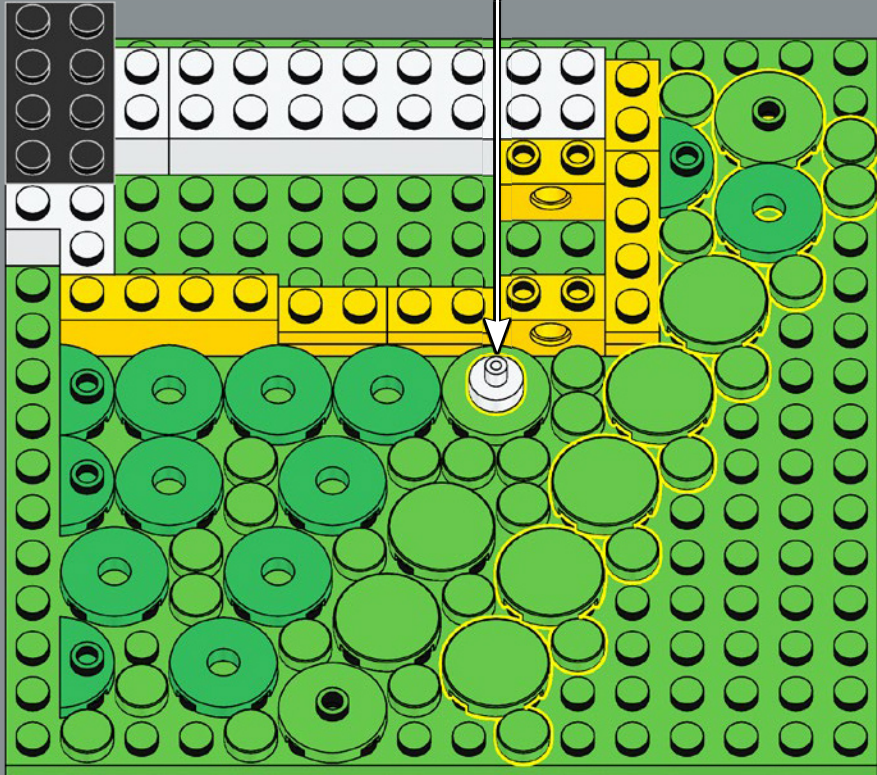

99

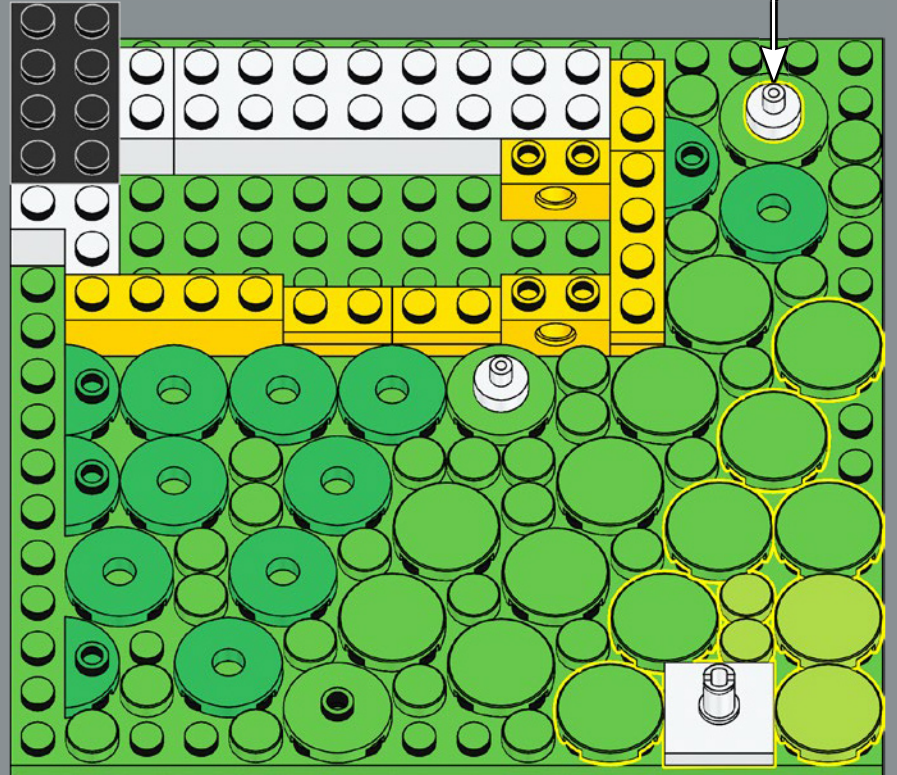

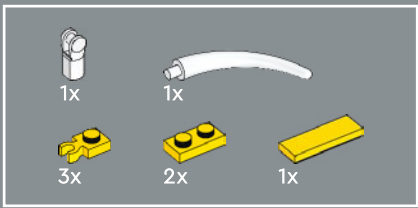

100

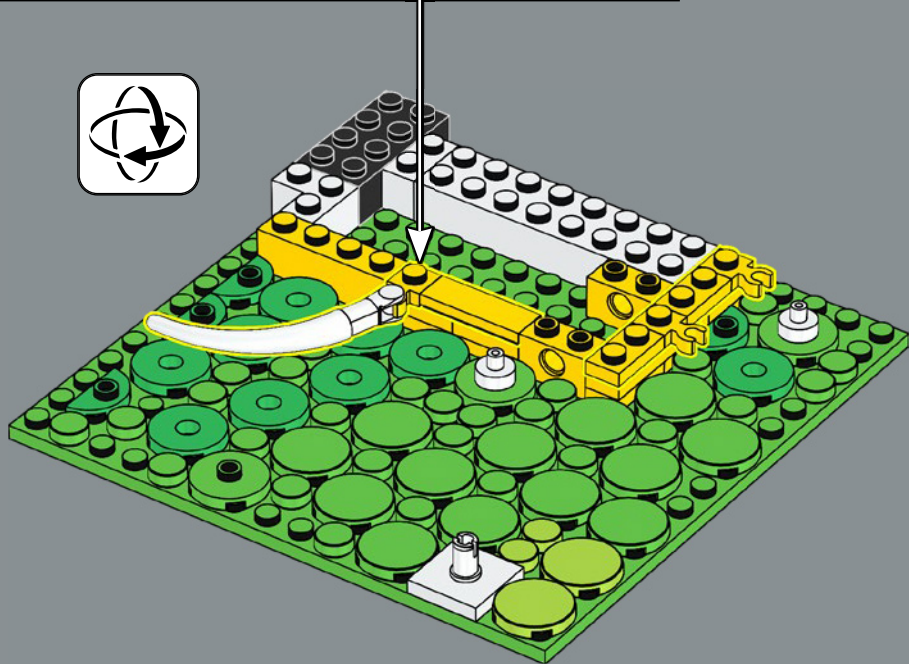
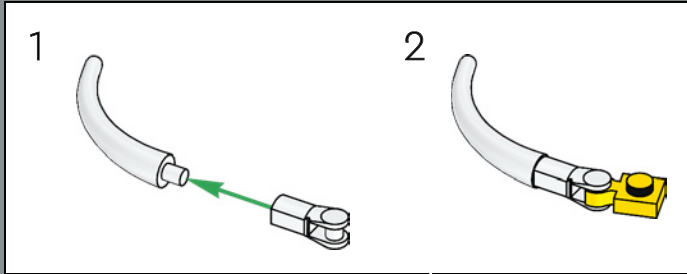

101

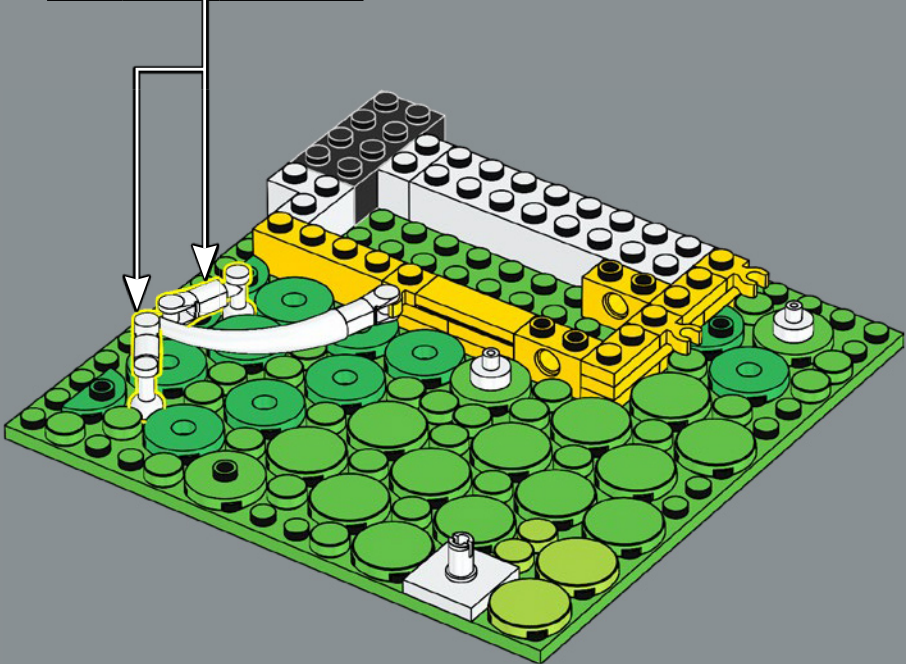
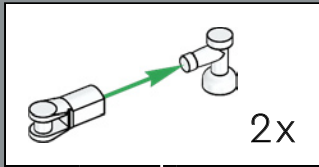



102

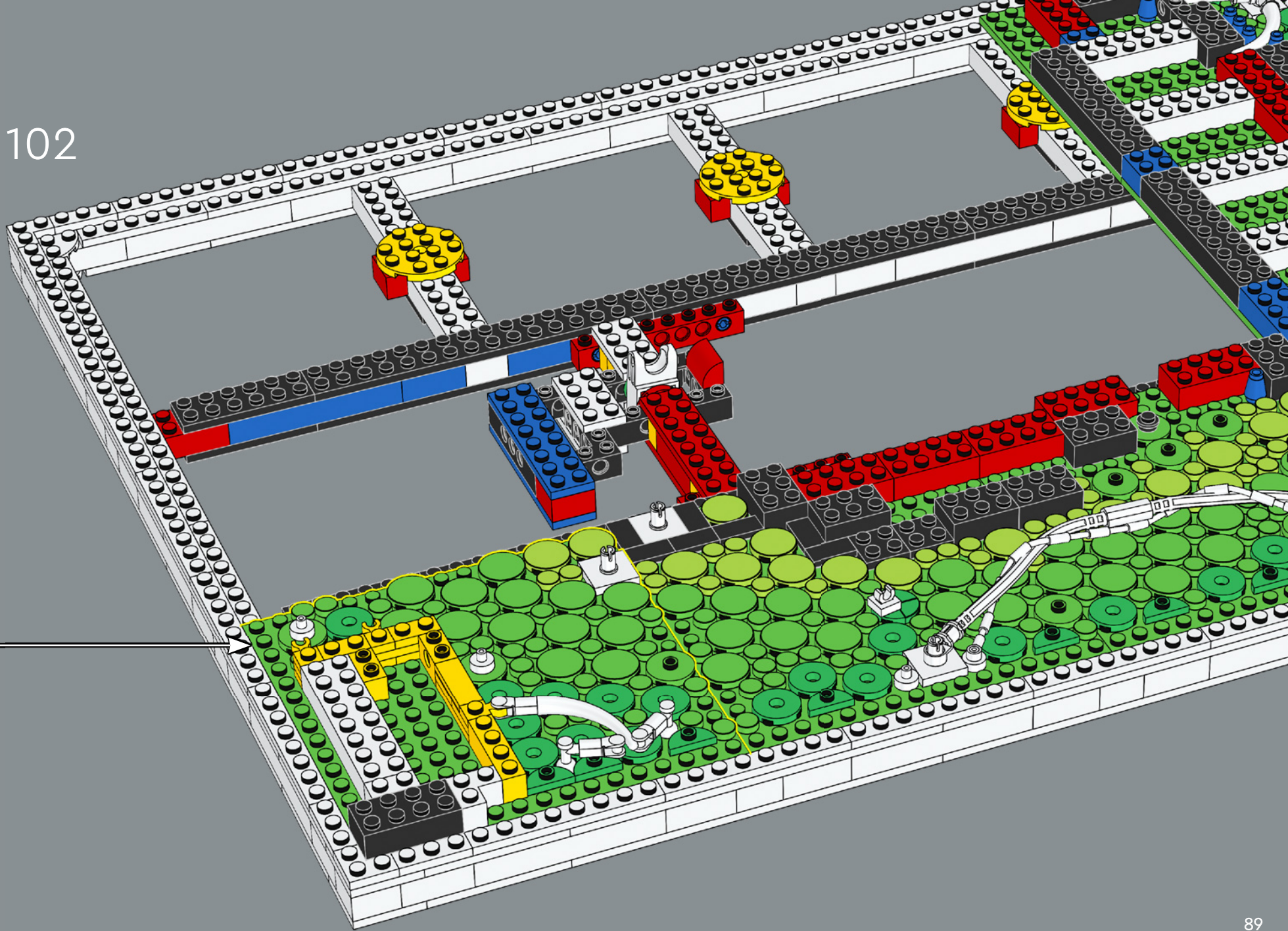

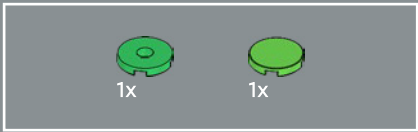

103

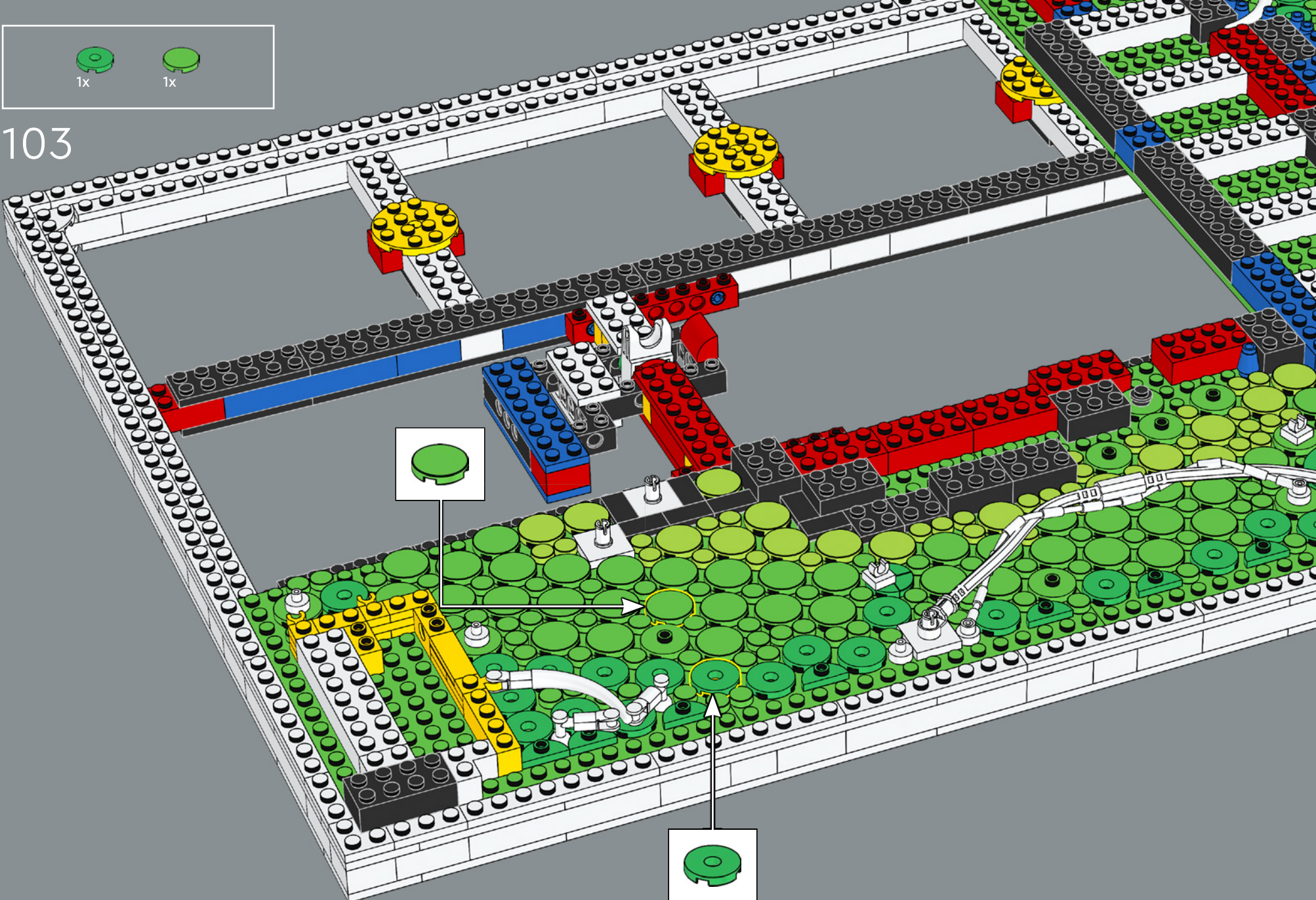

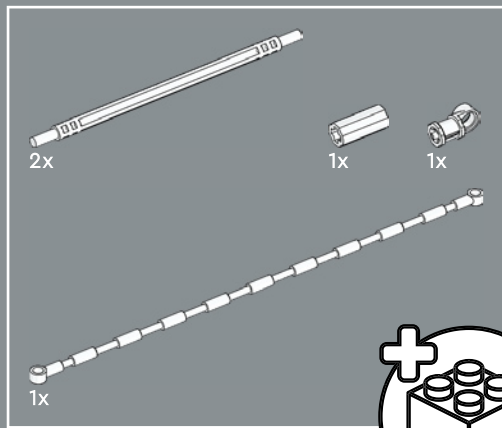

104

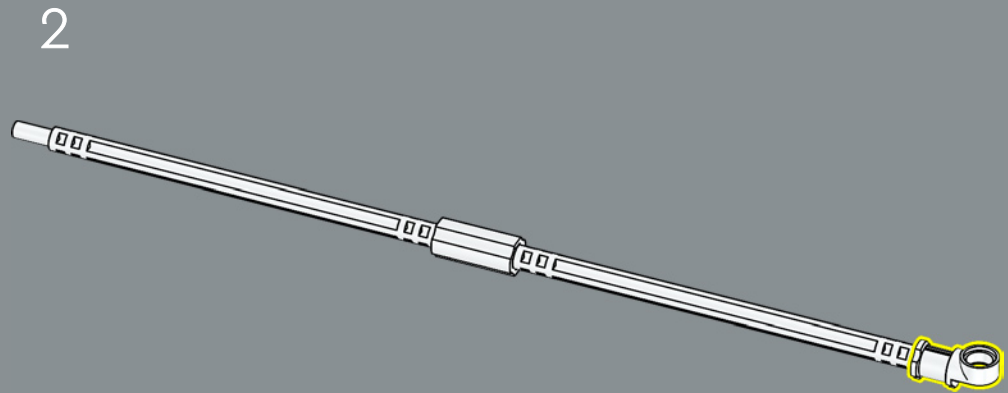
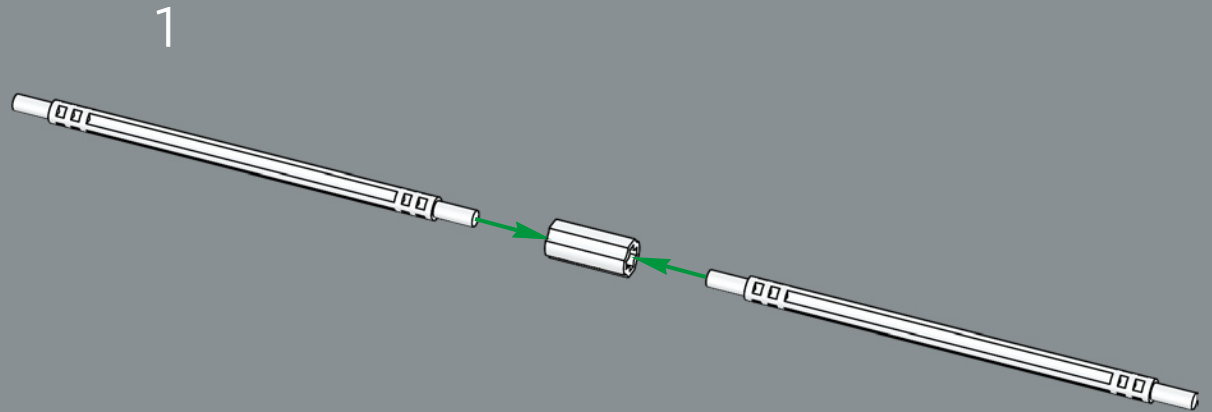
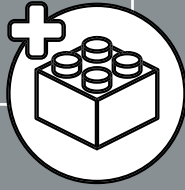

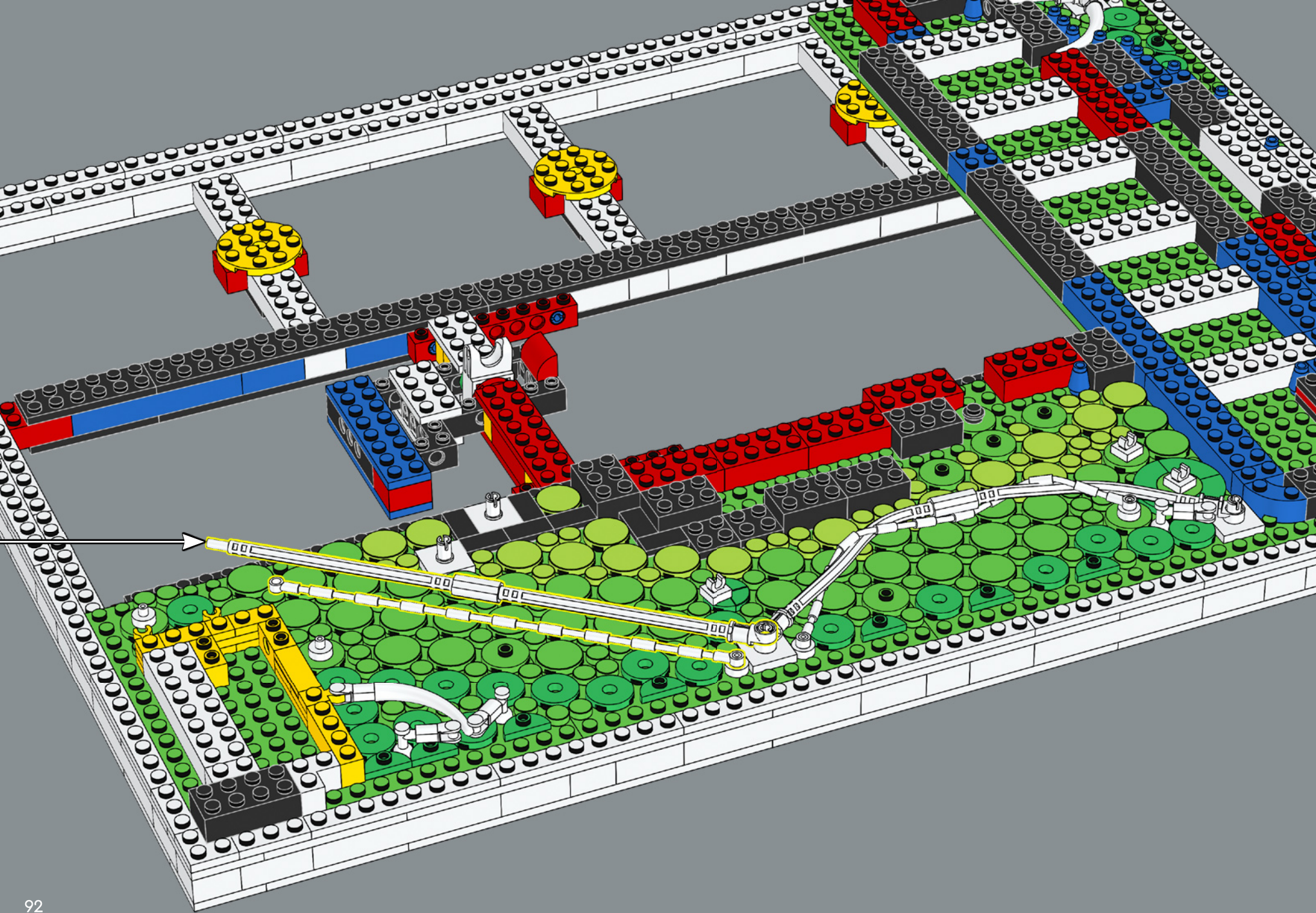

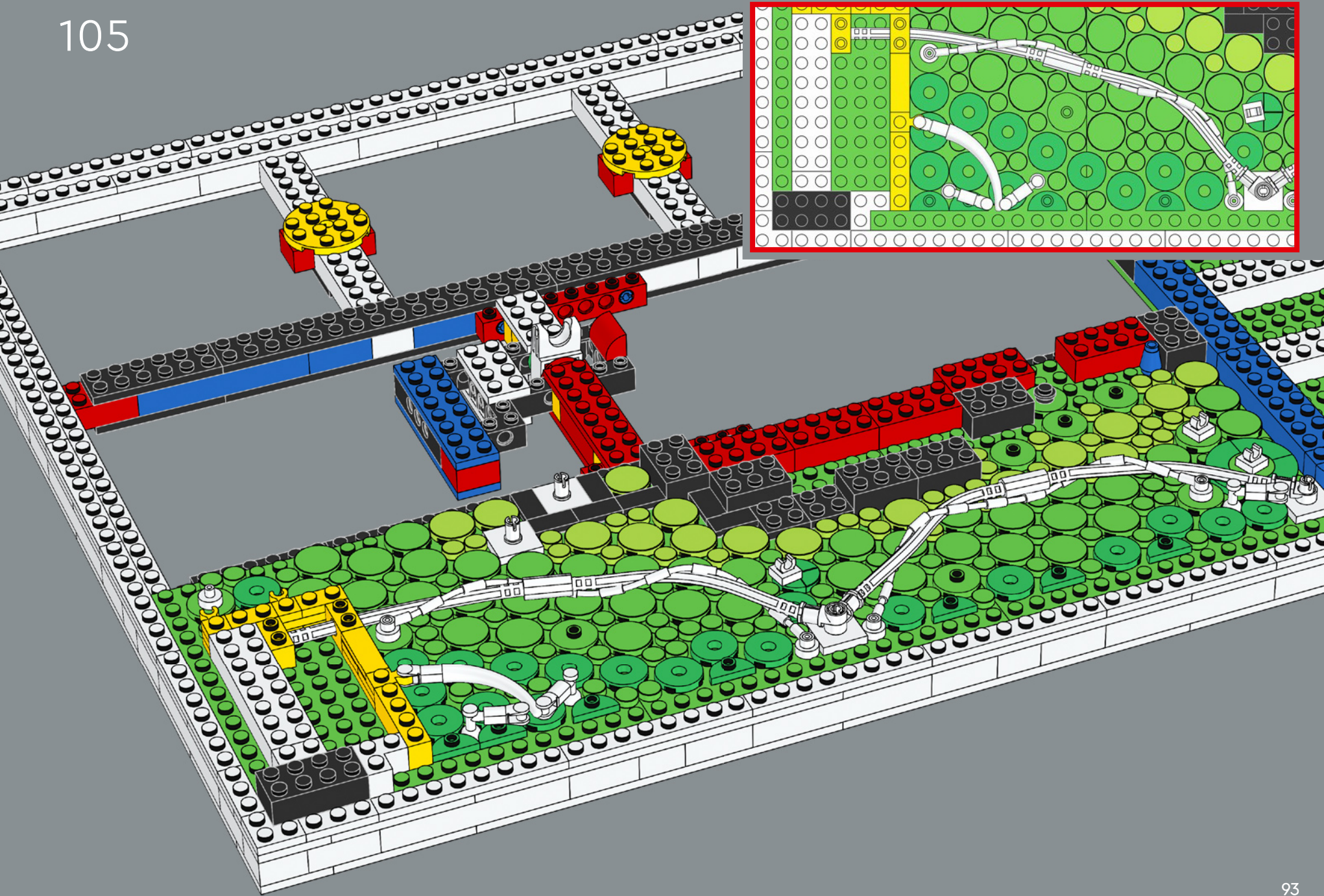

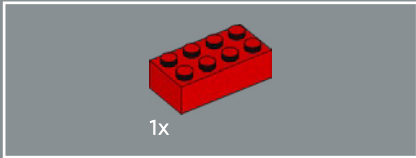
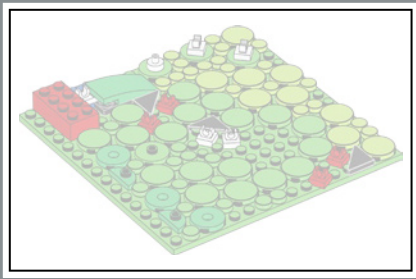

106

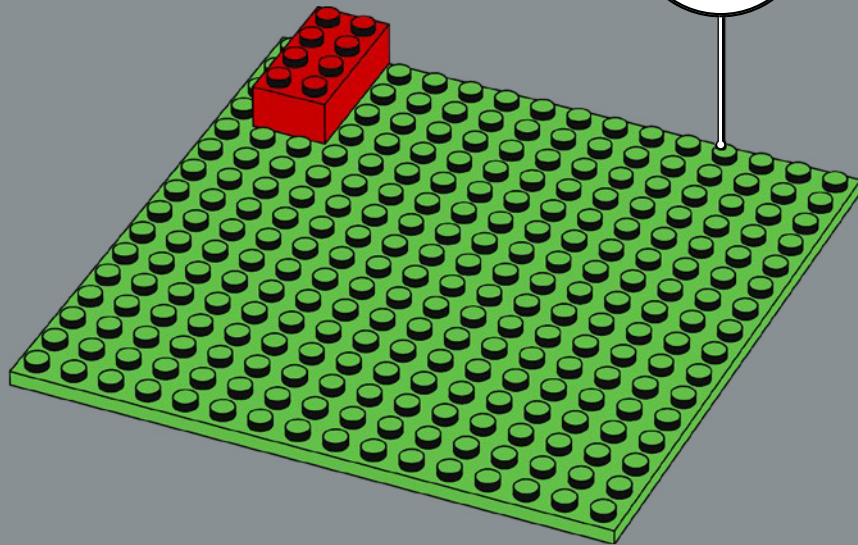
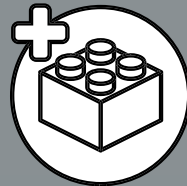

107

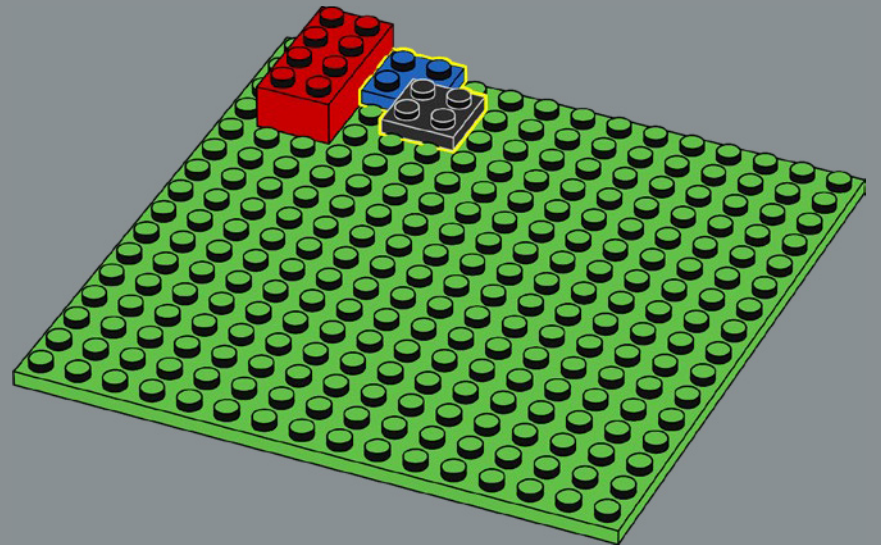

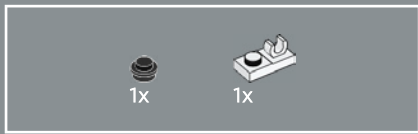

108

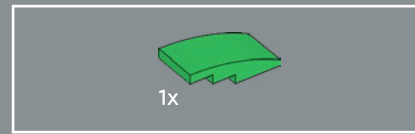
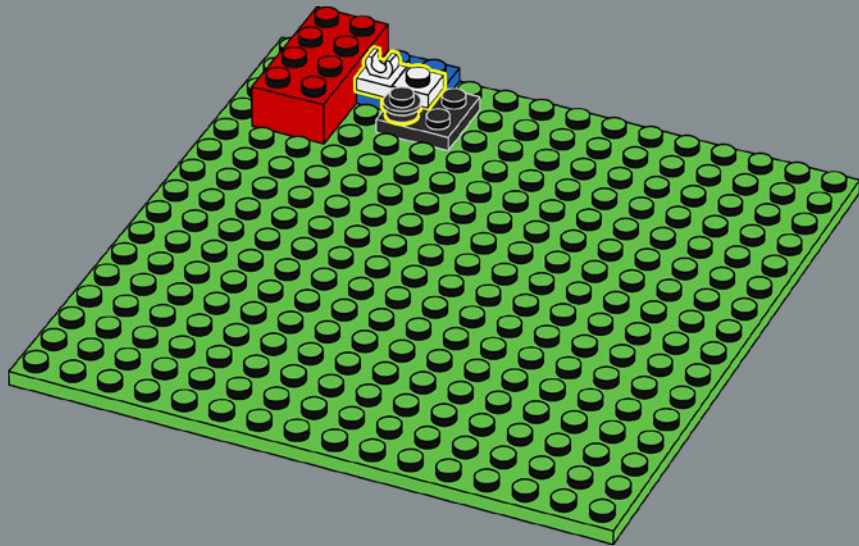

109

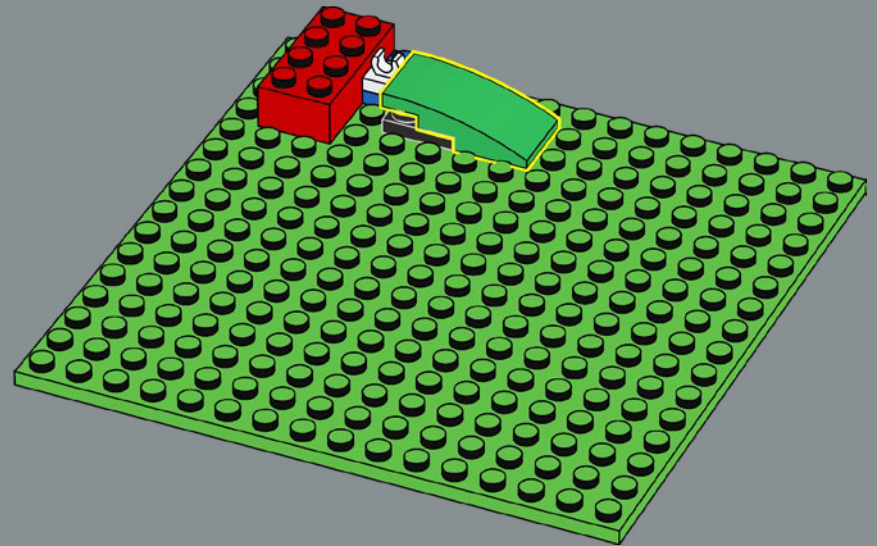



110

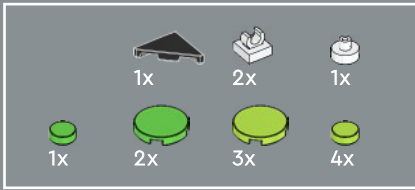
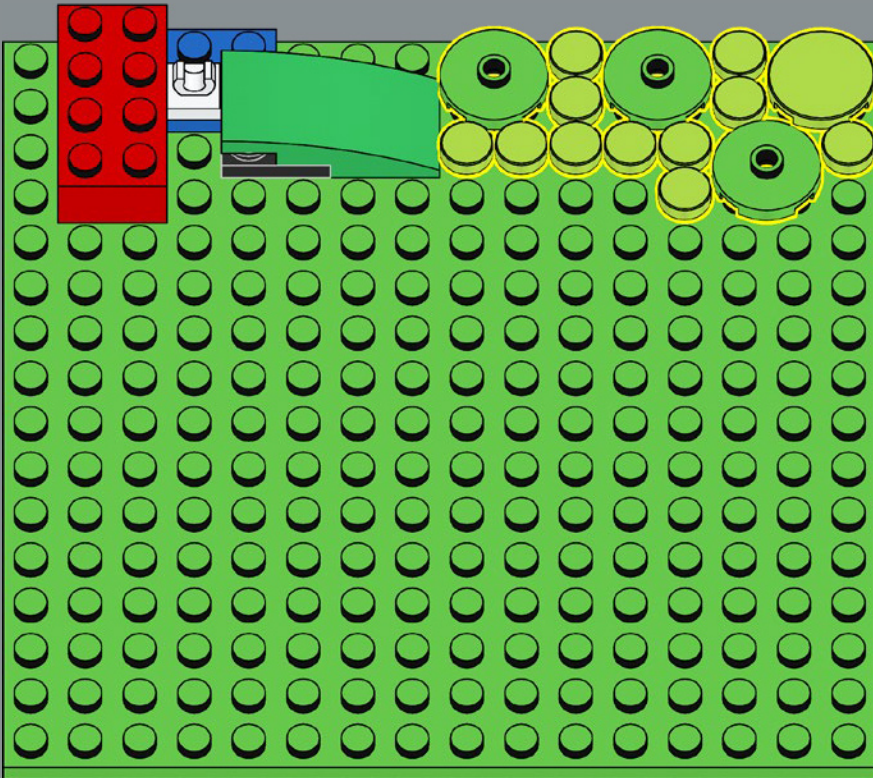

111

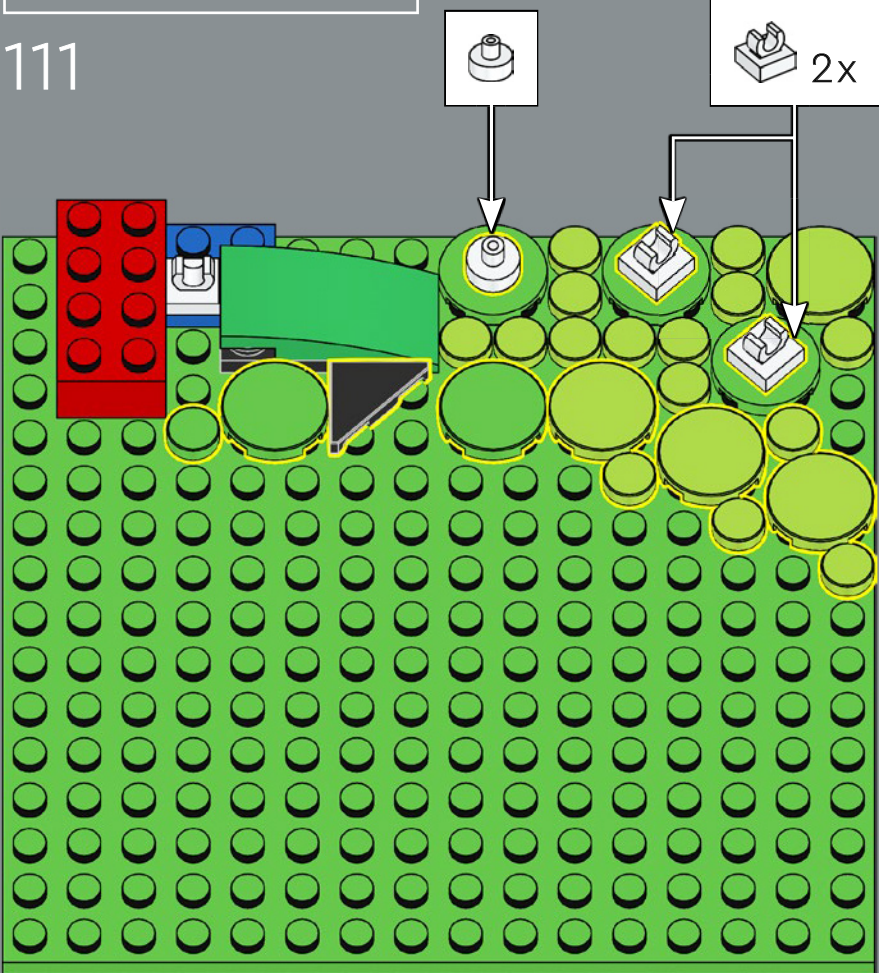





112

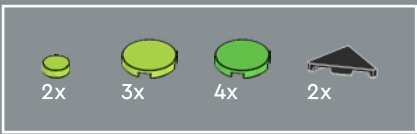
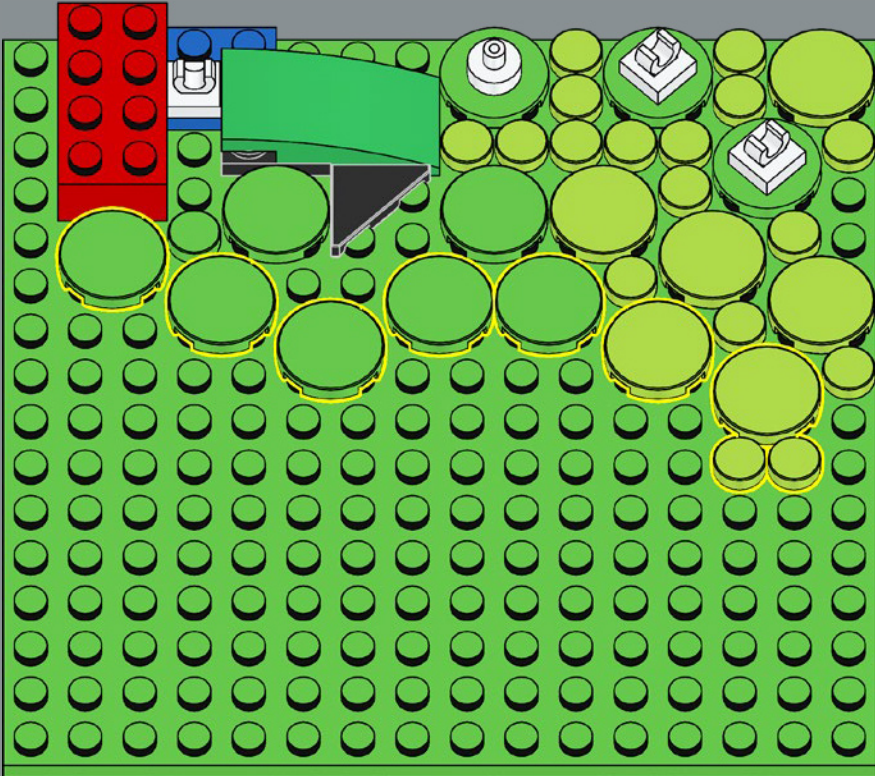

113

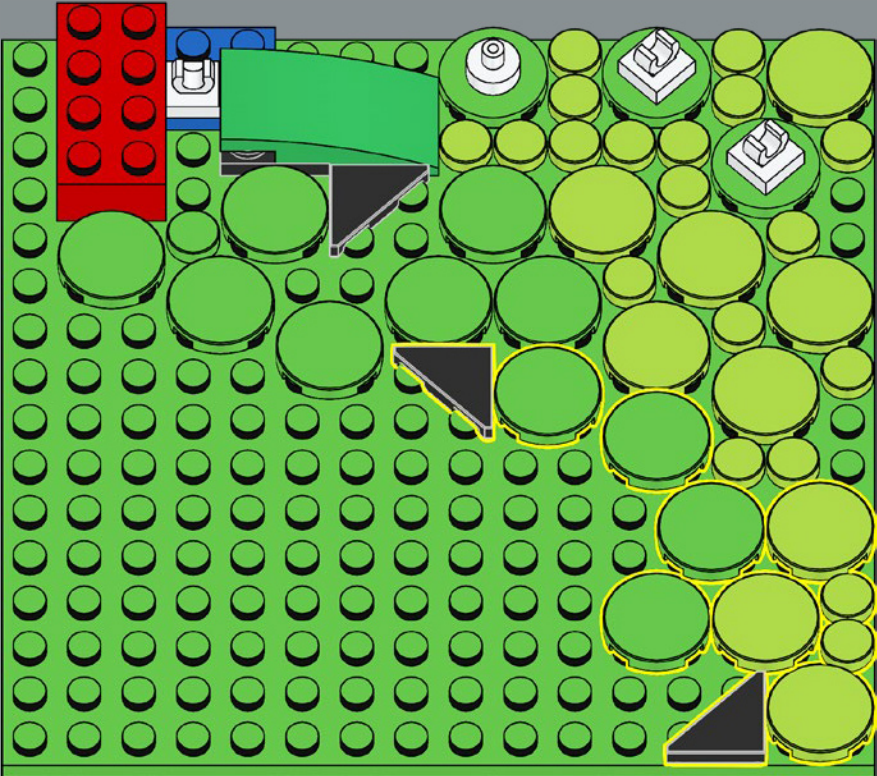





118

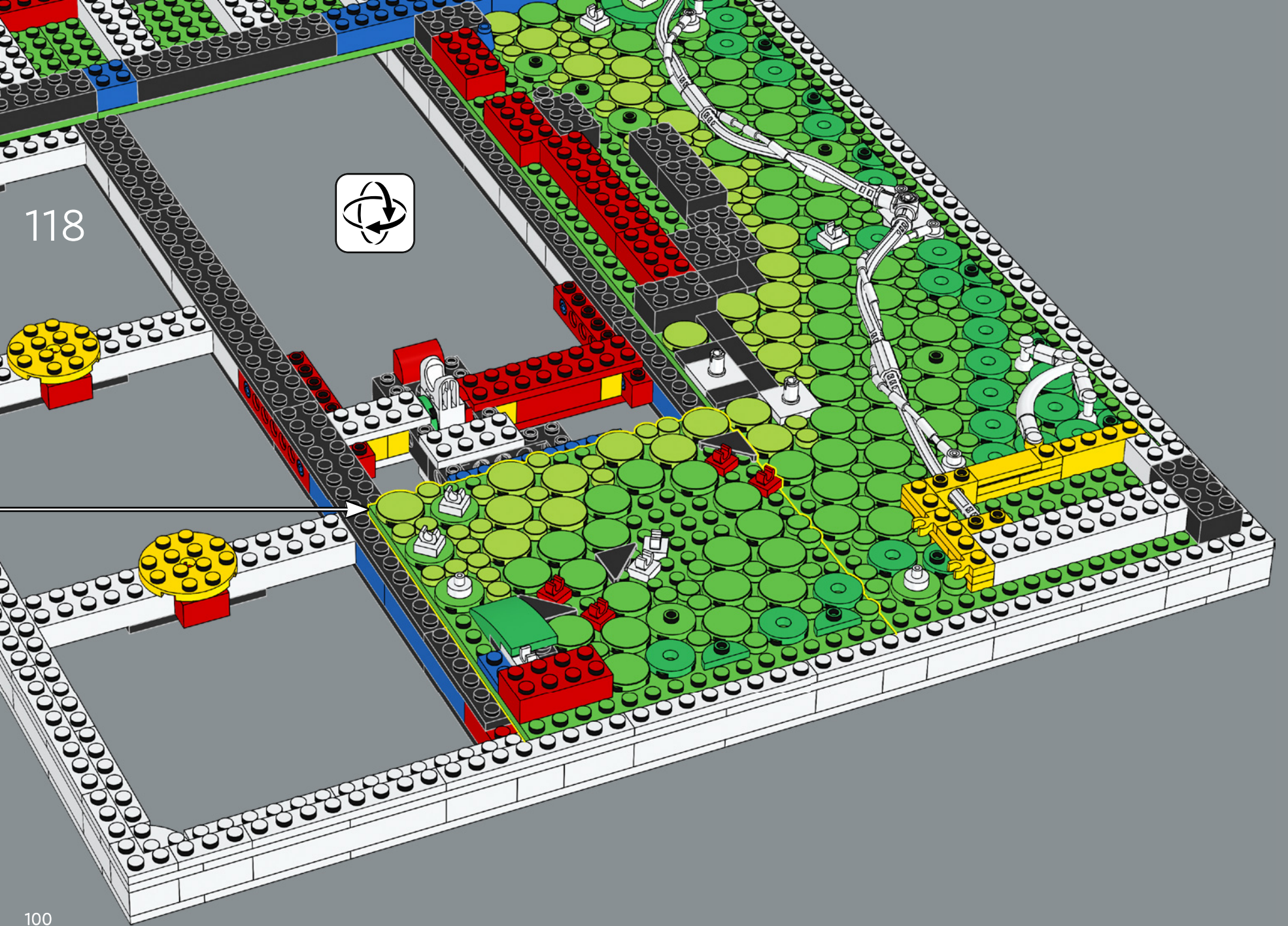

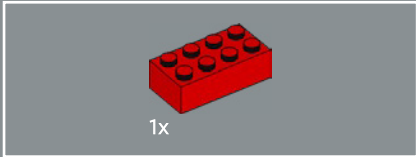
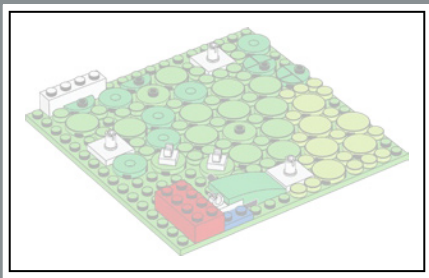

119

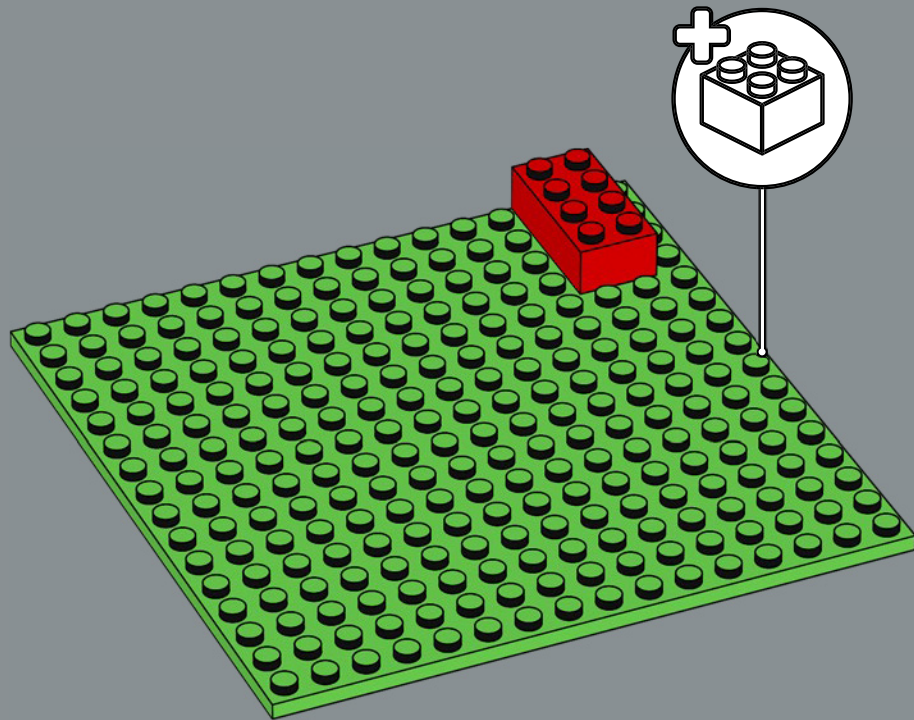

120

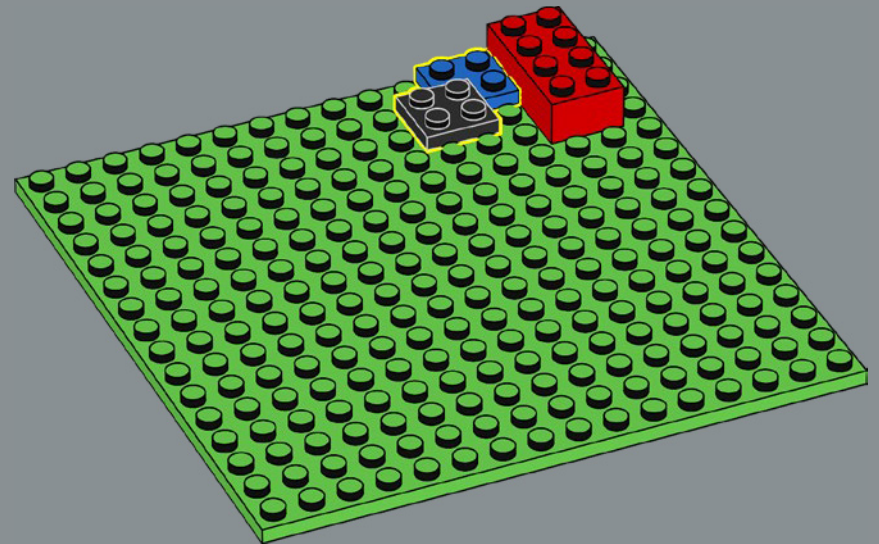



121

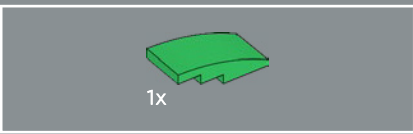
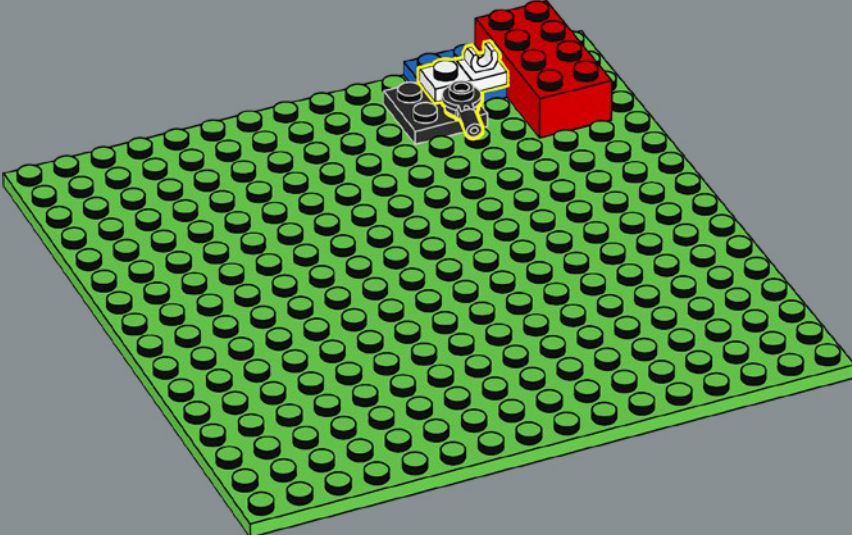

122

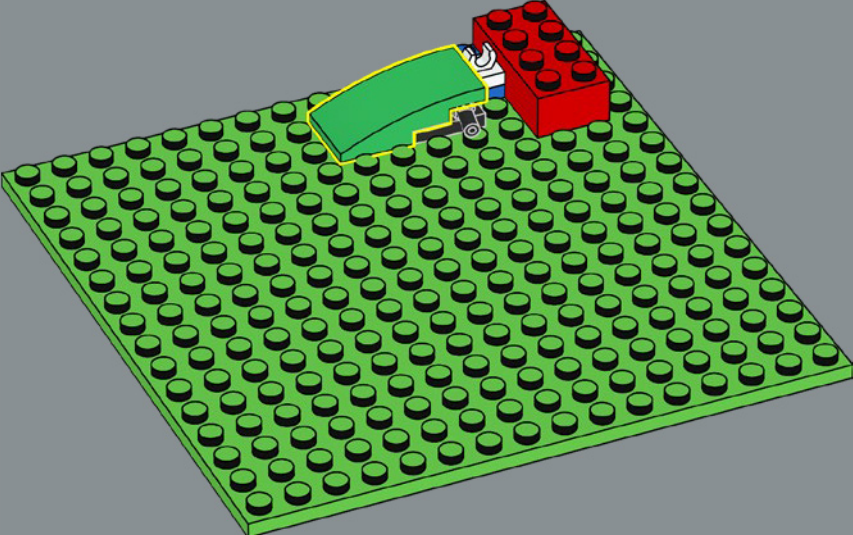



123

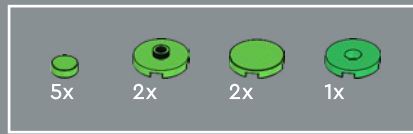
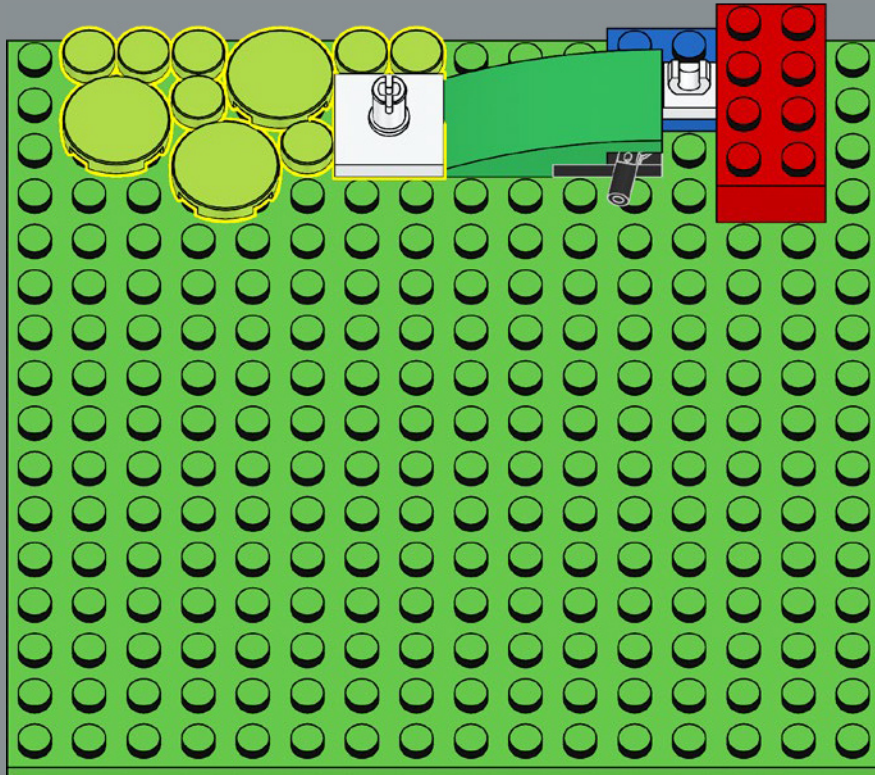

124

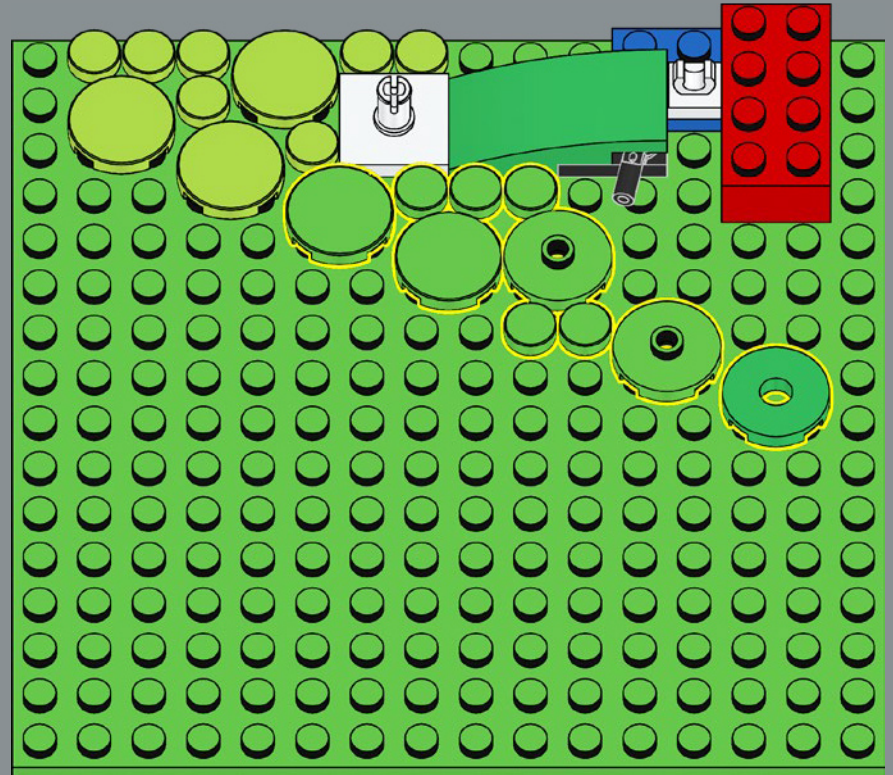



125

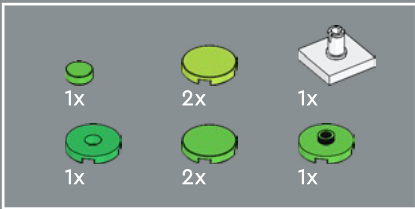
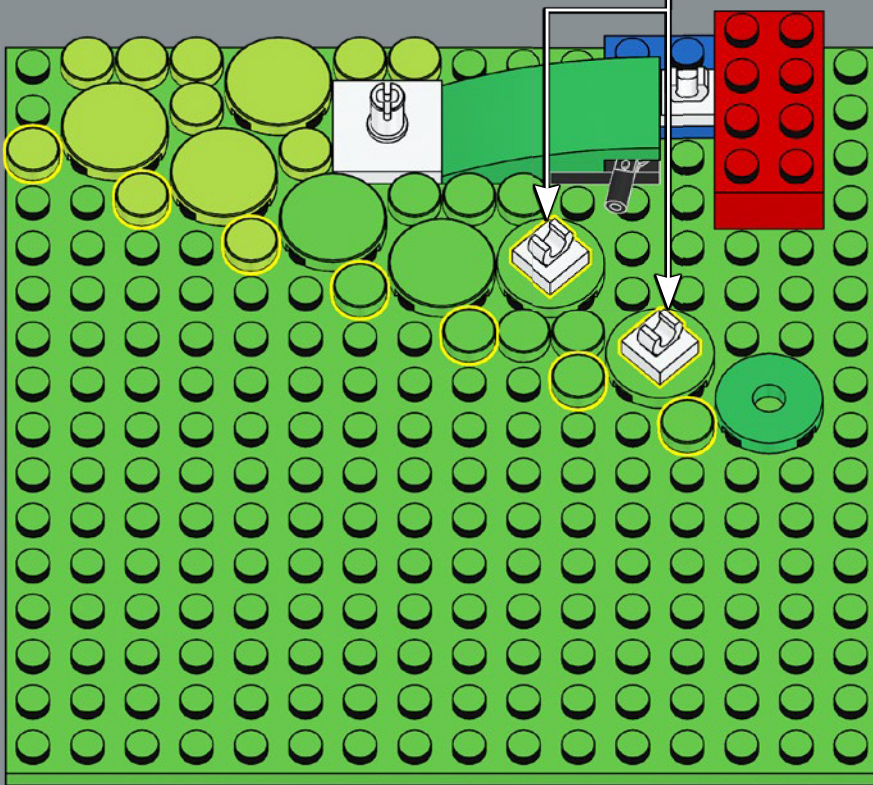

126

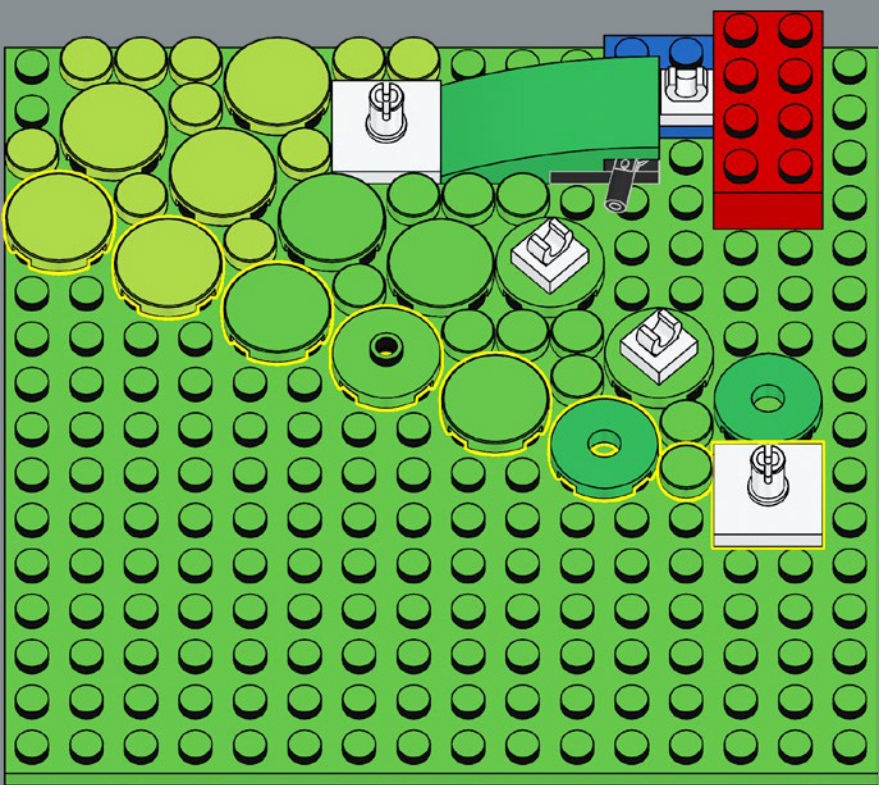





127

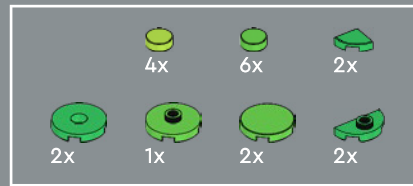
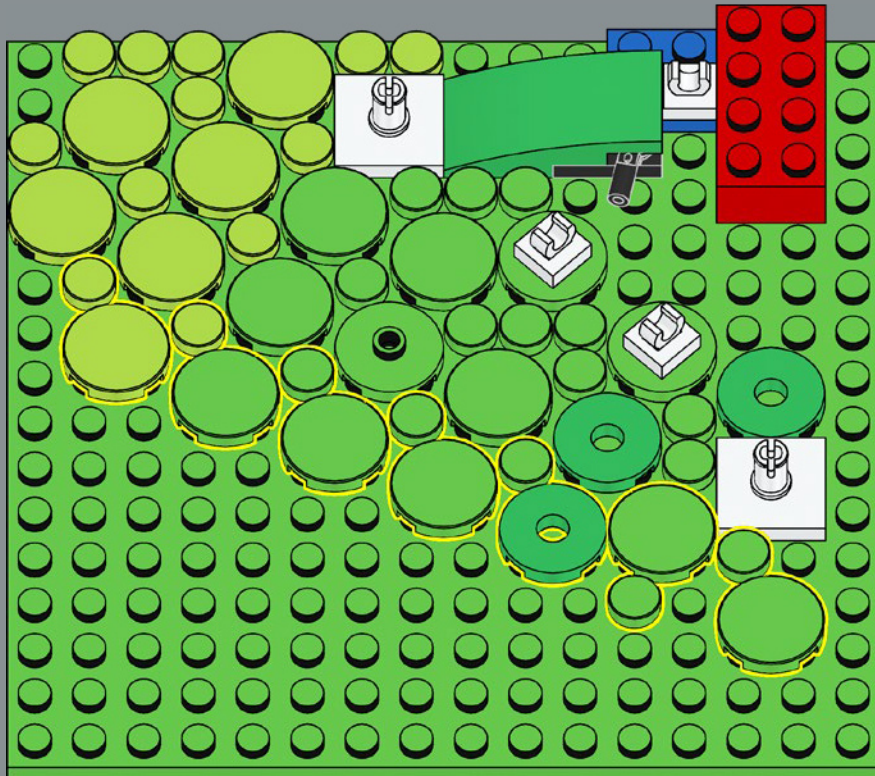

128

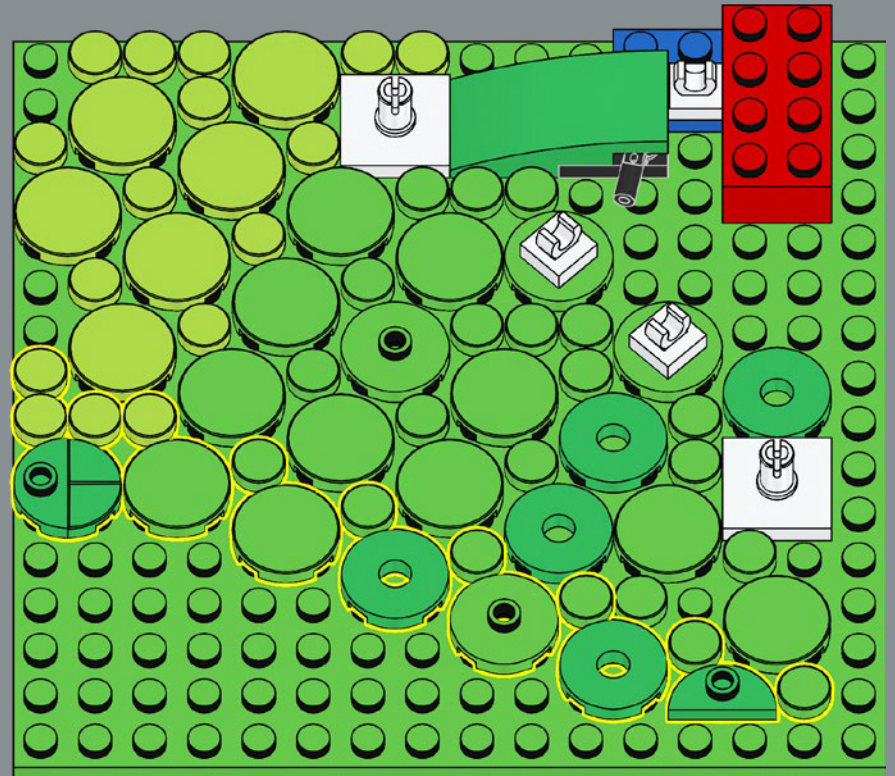

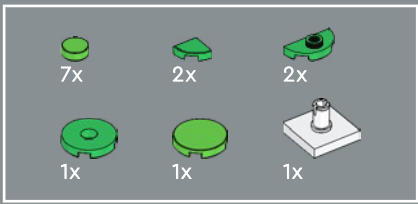

129

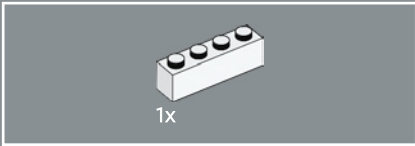
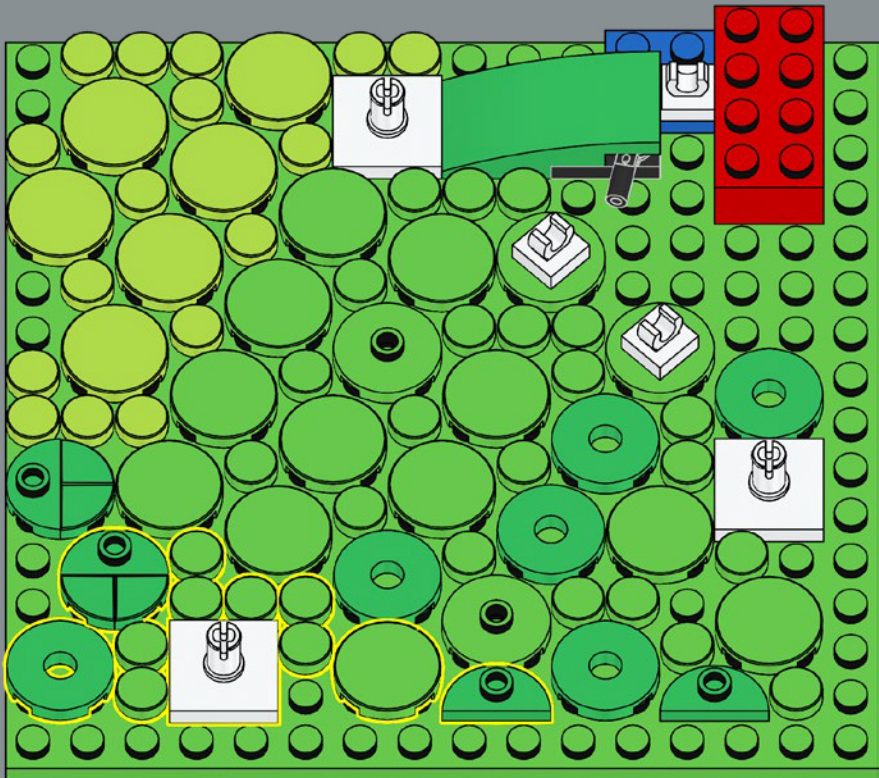

130

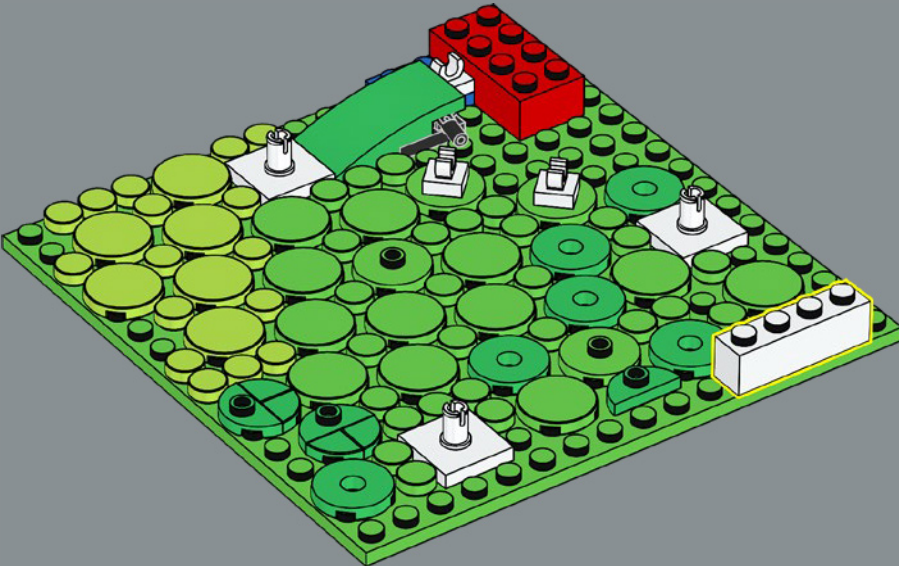

131

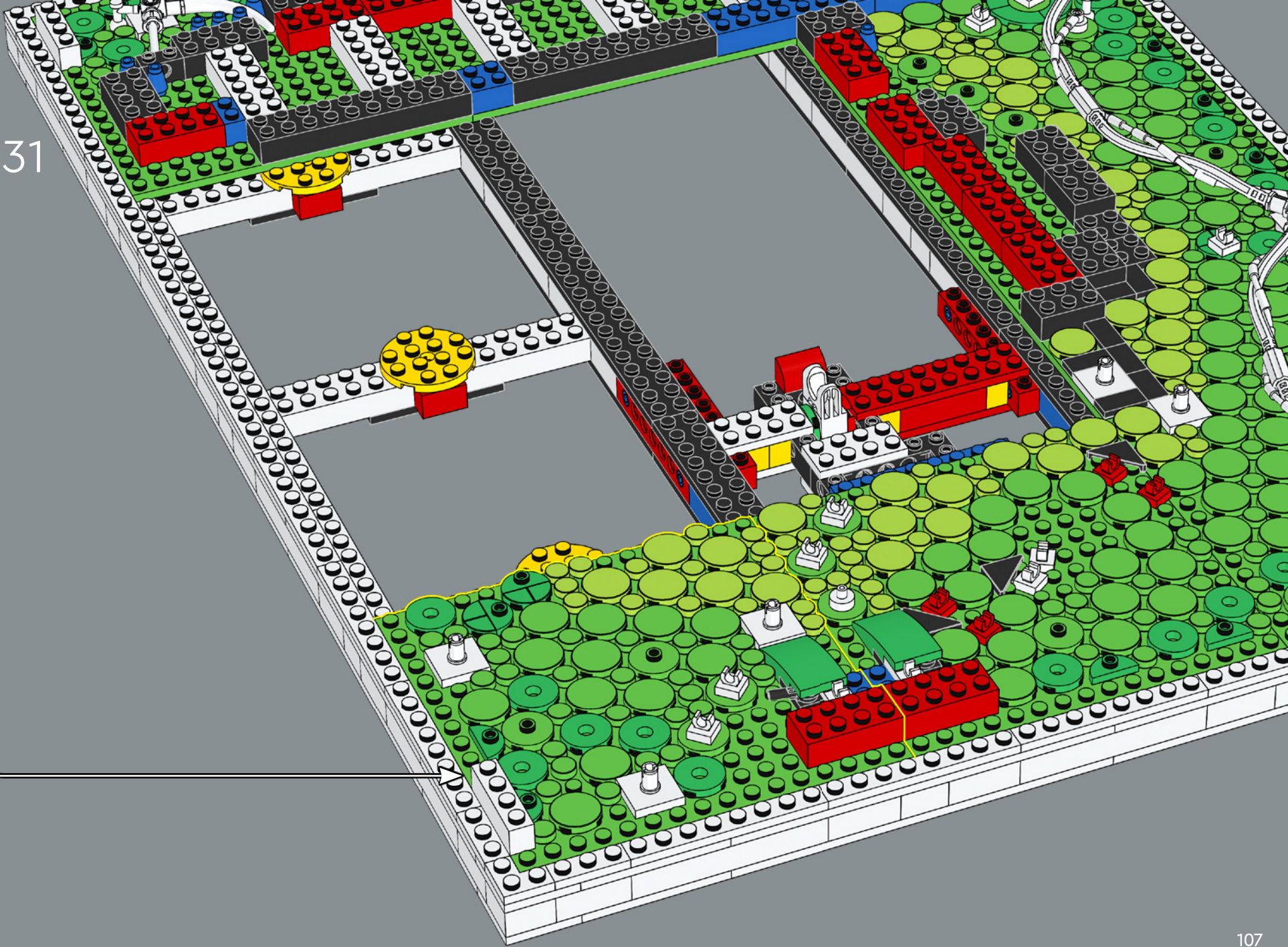

3x

132

3x

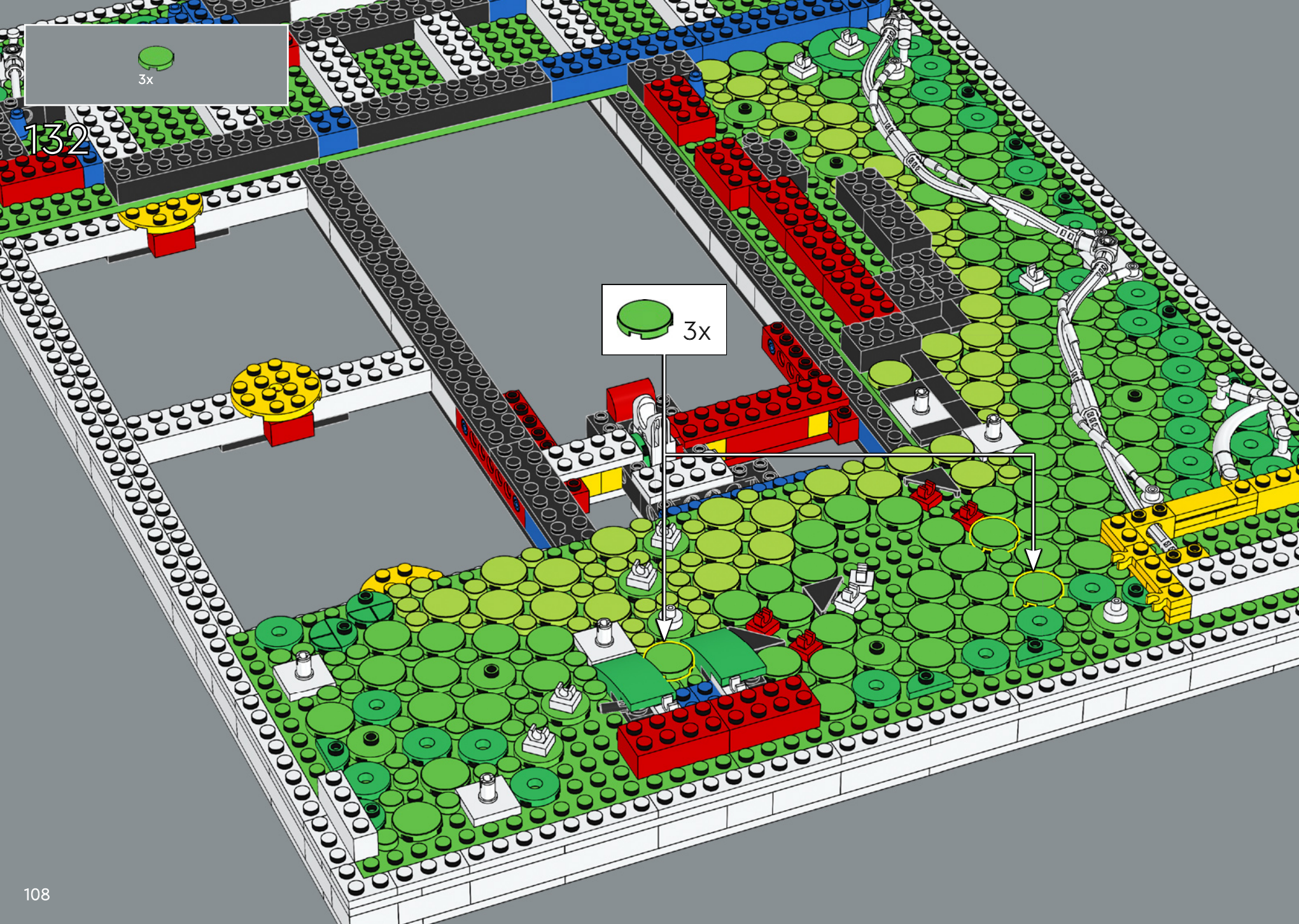

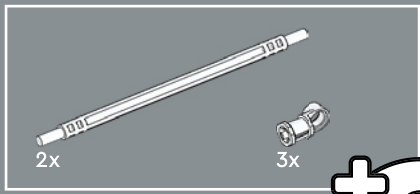

133

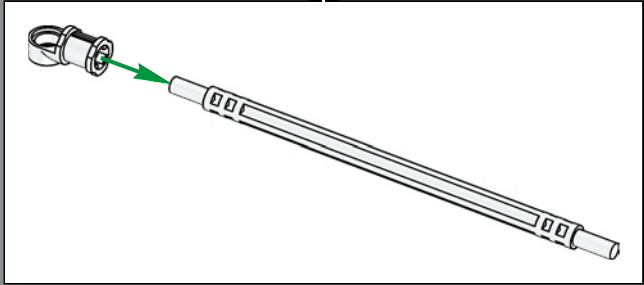
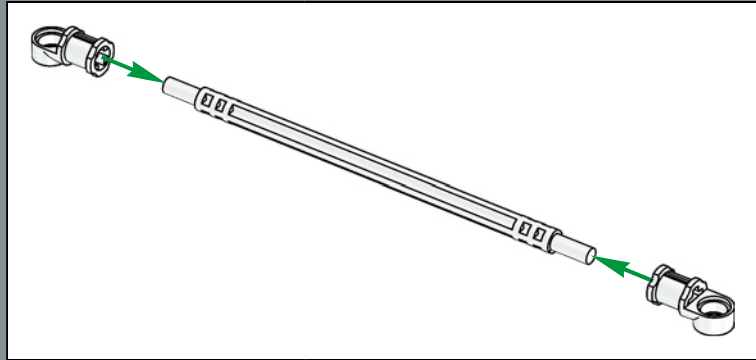
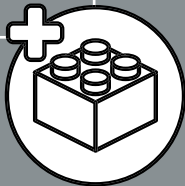

134

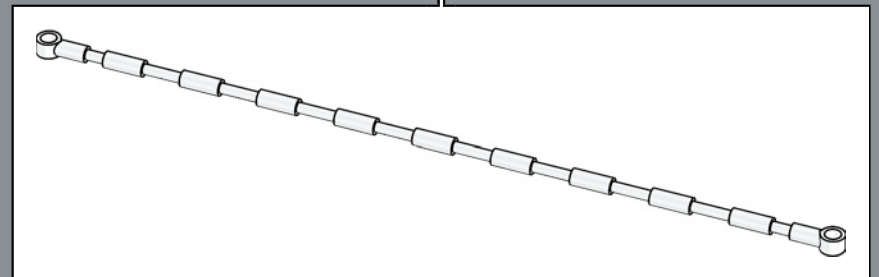
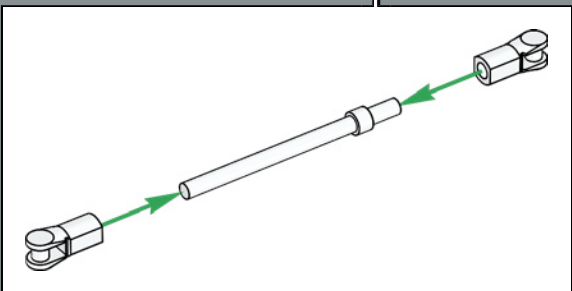
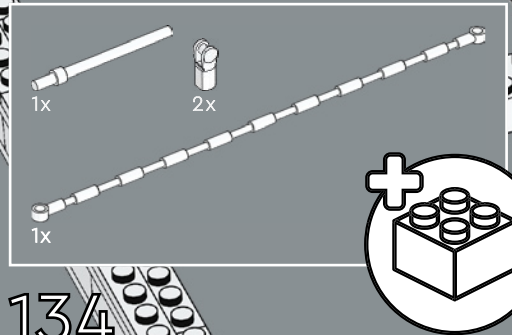

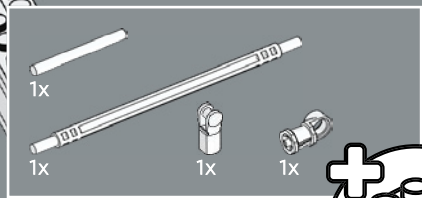

135

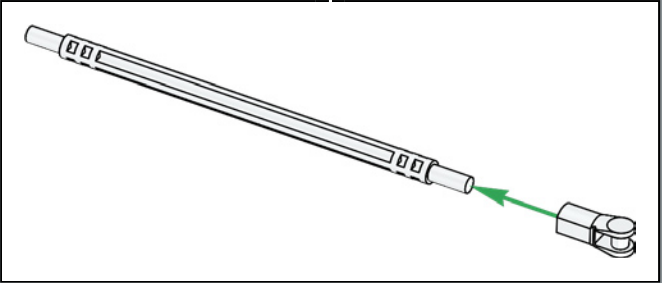
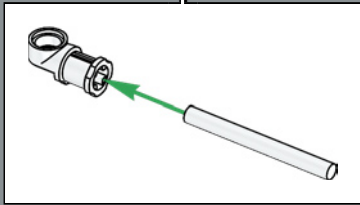
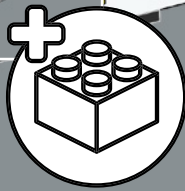

4x  
1x

136

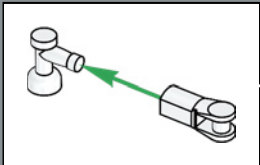

3x



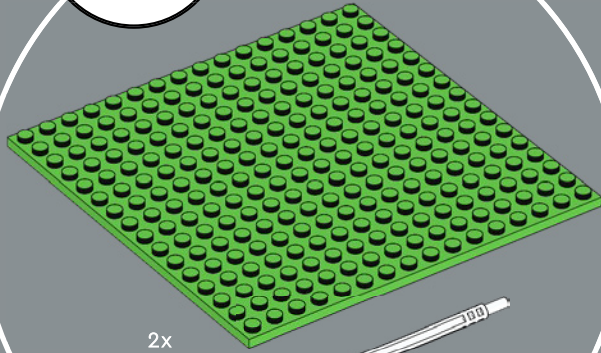
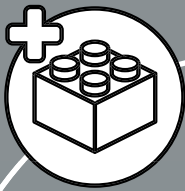

2x

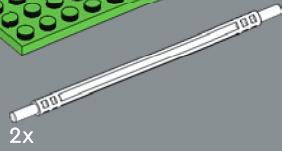

2x

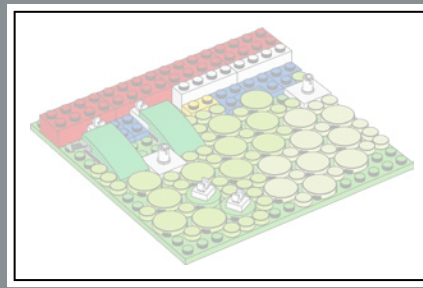

1x

137

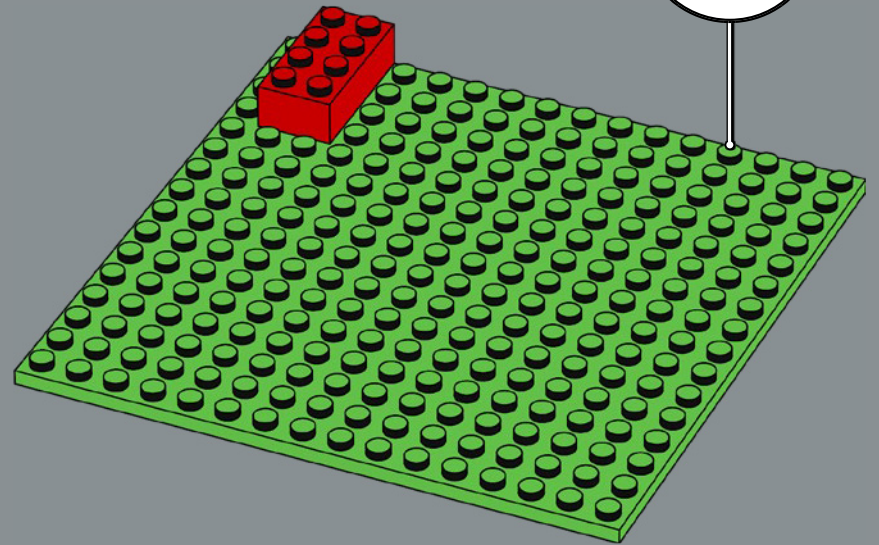
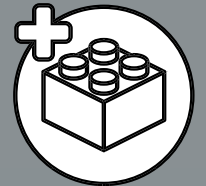

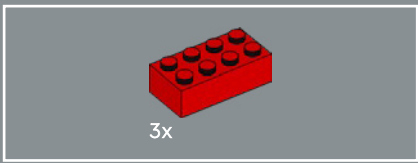

138

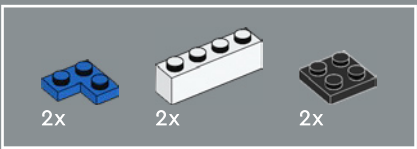
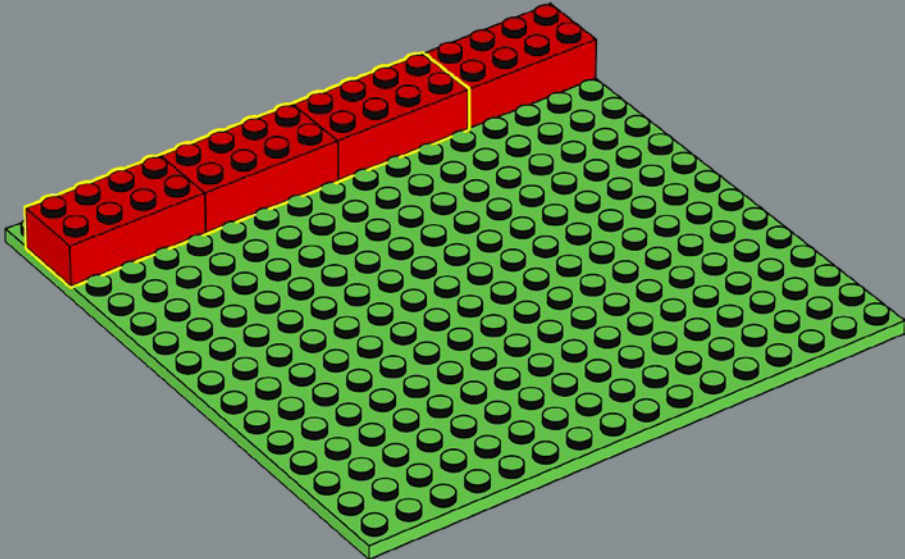

139

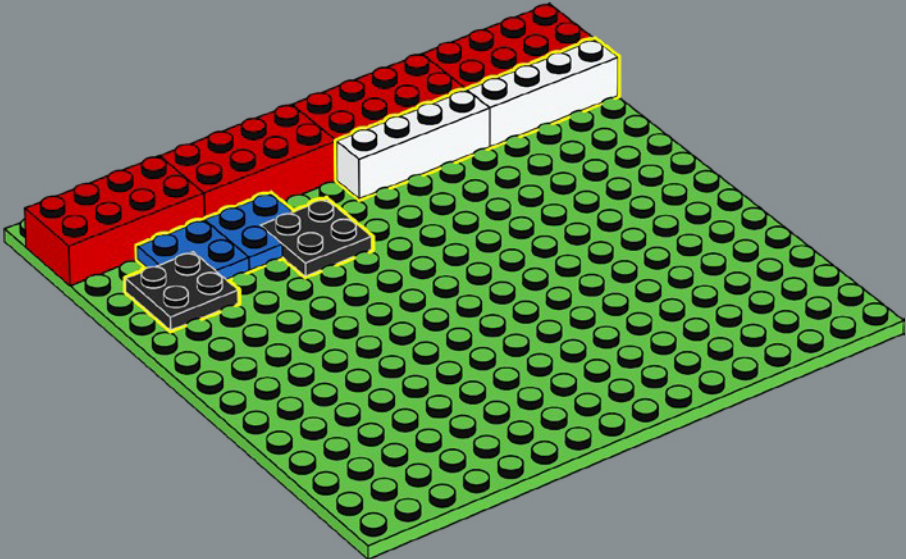



140

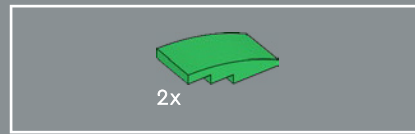
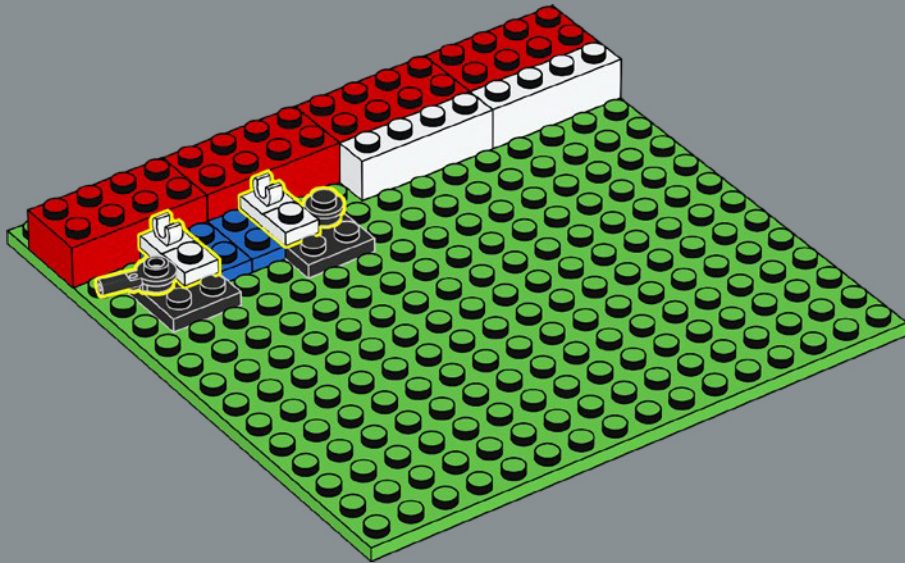

141

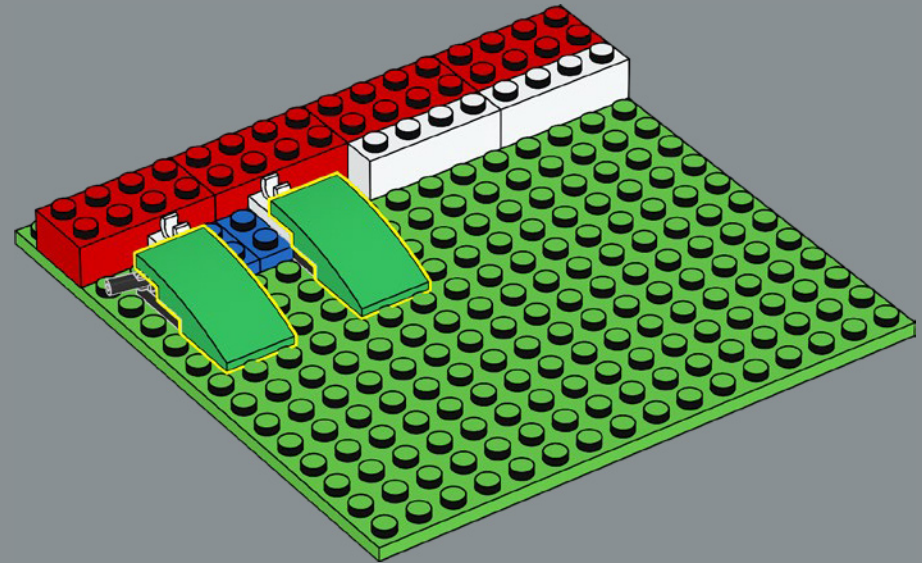

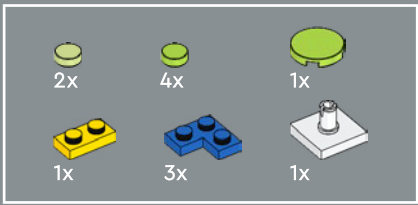

142

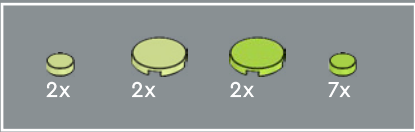
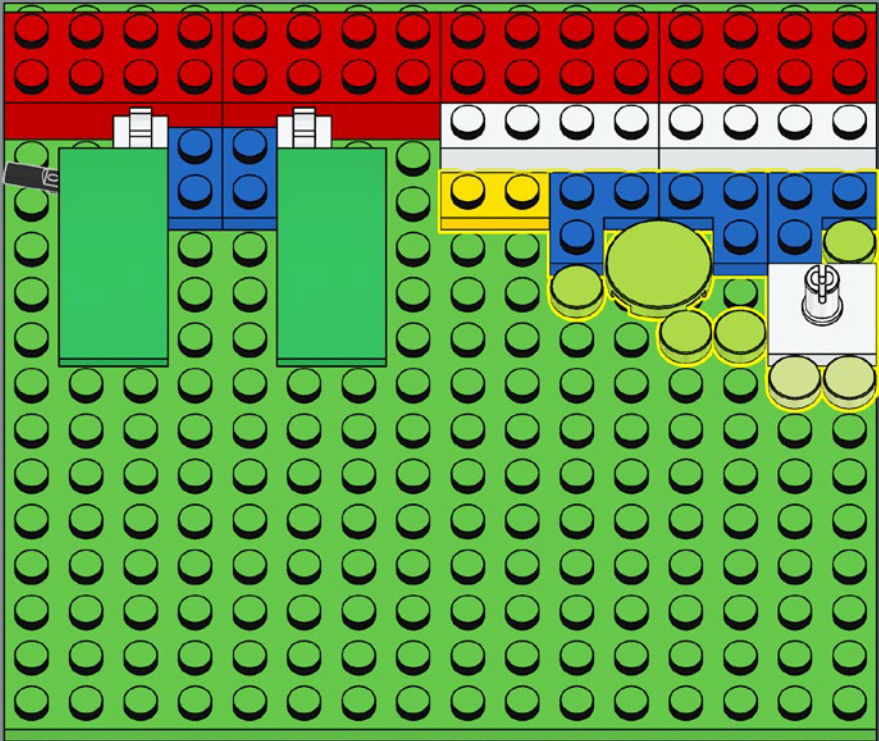

143

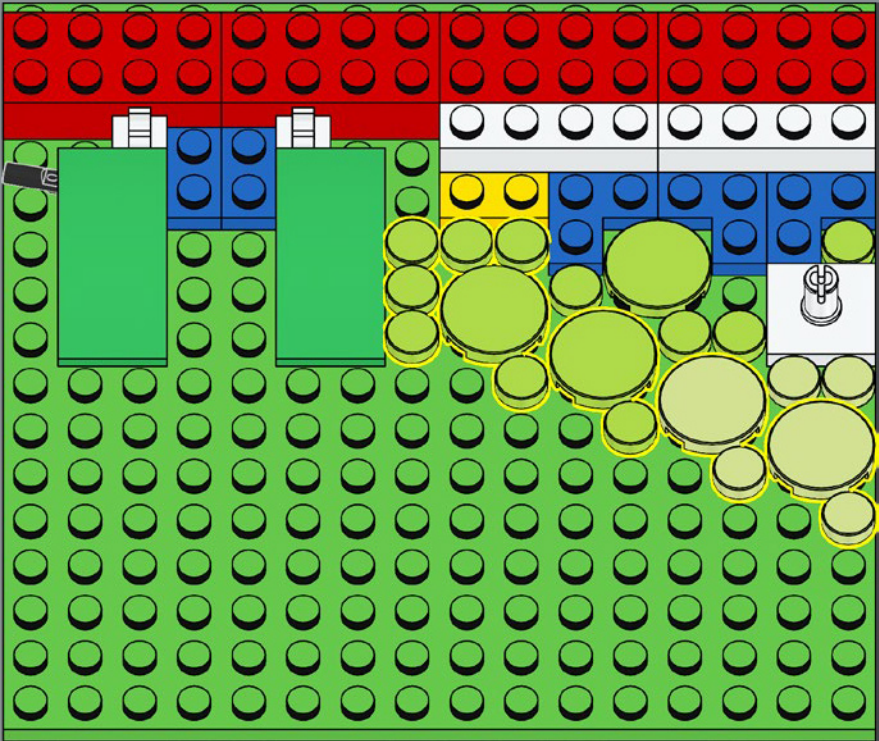

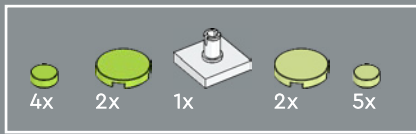

144

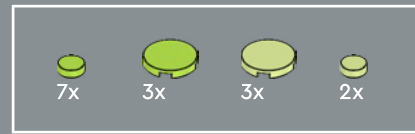
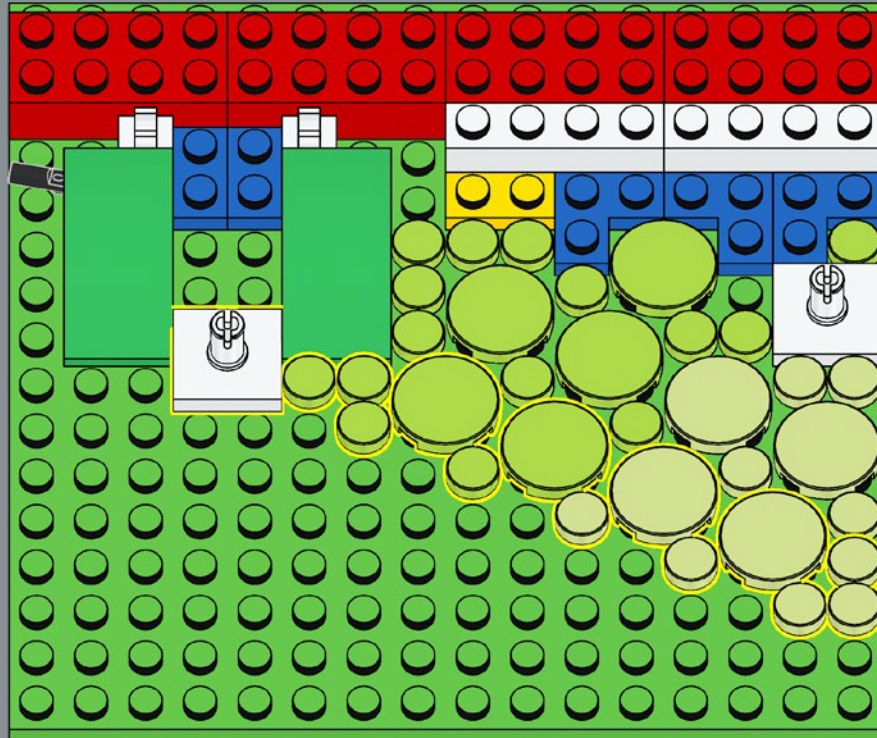

145

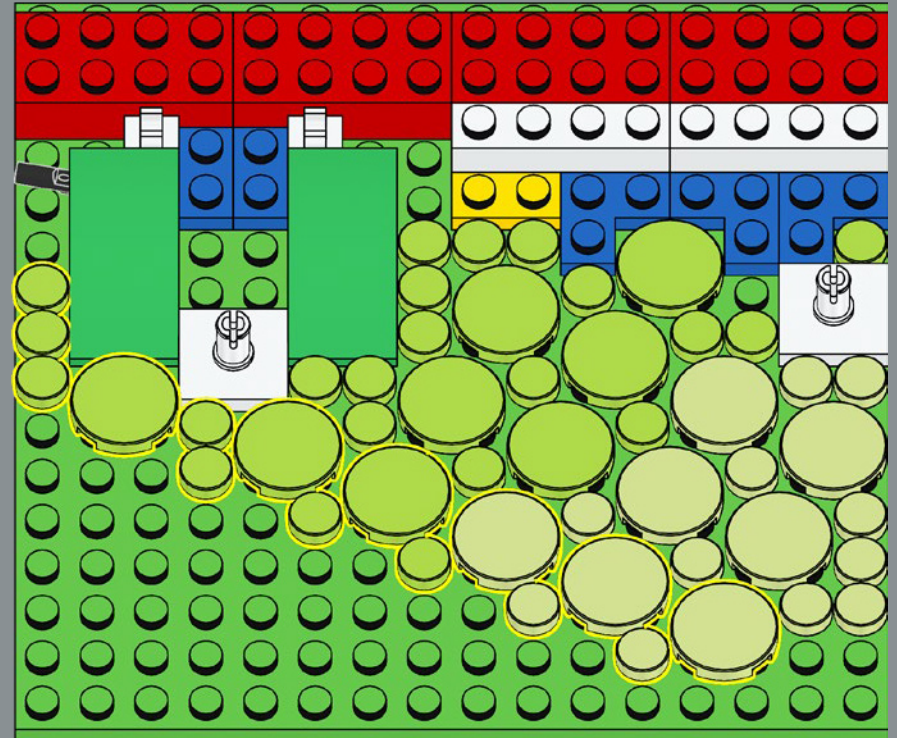



146

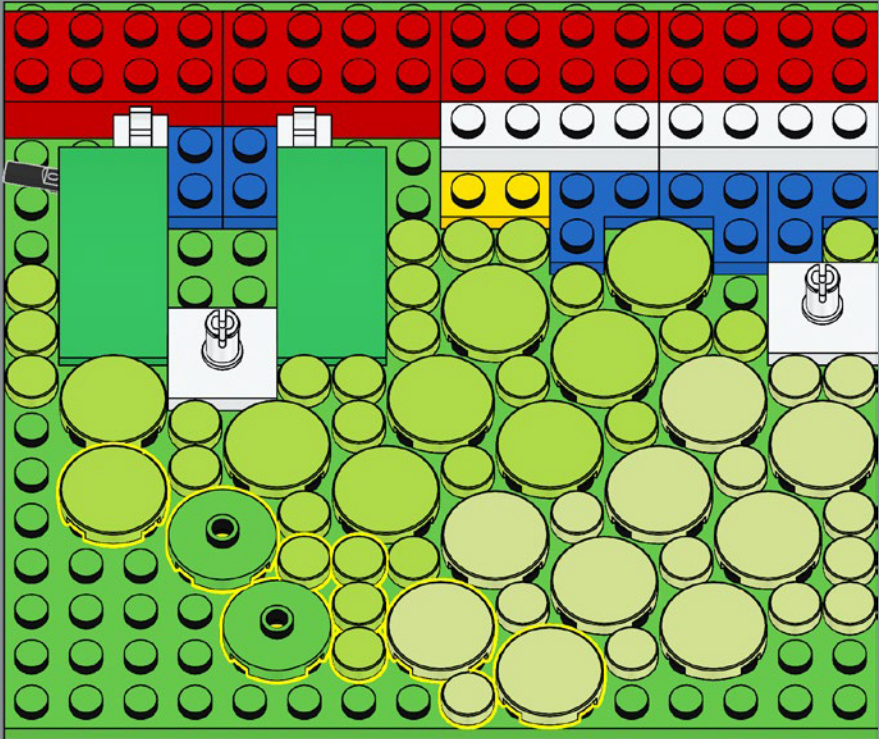

147

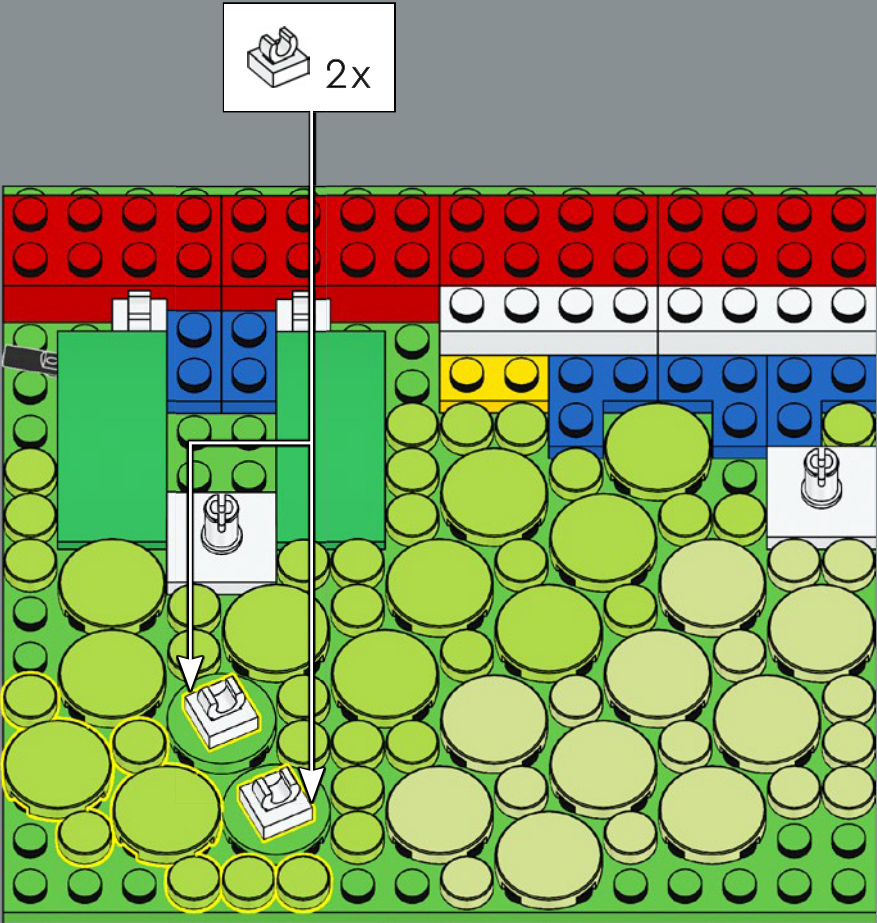

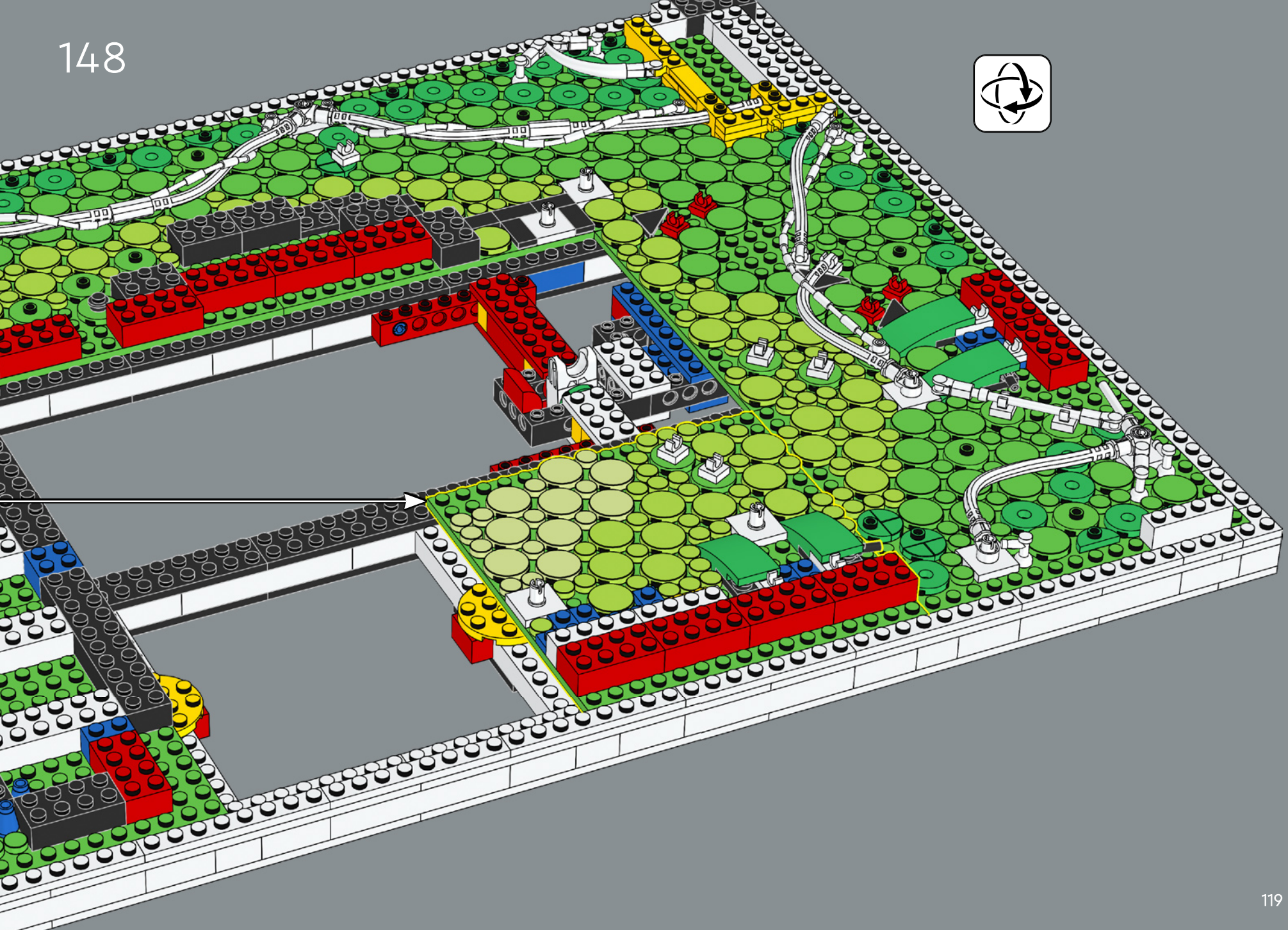

2x

149



2x

120

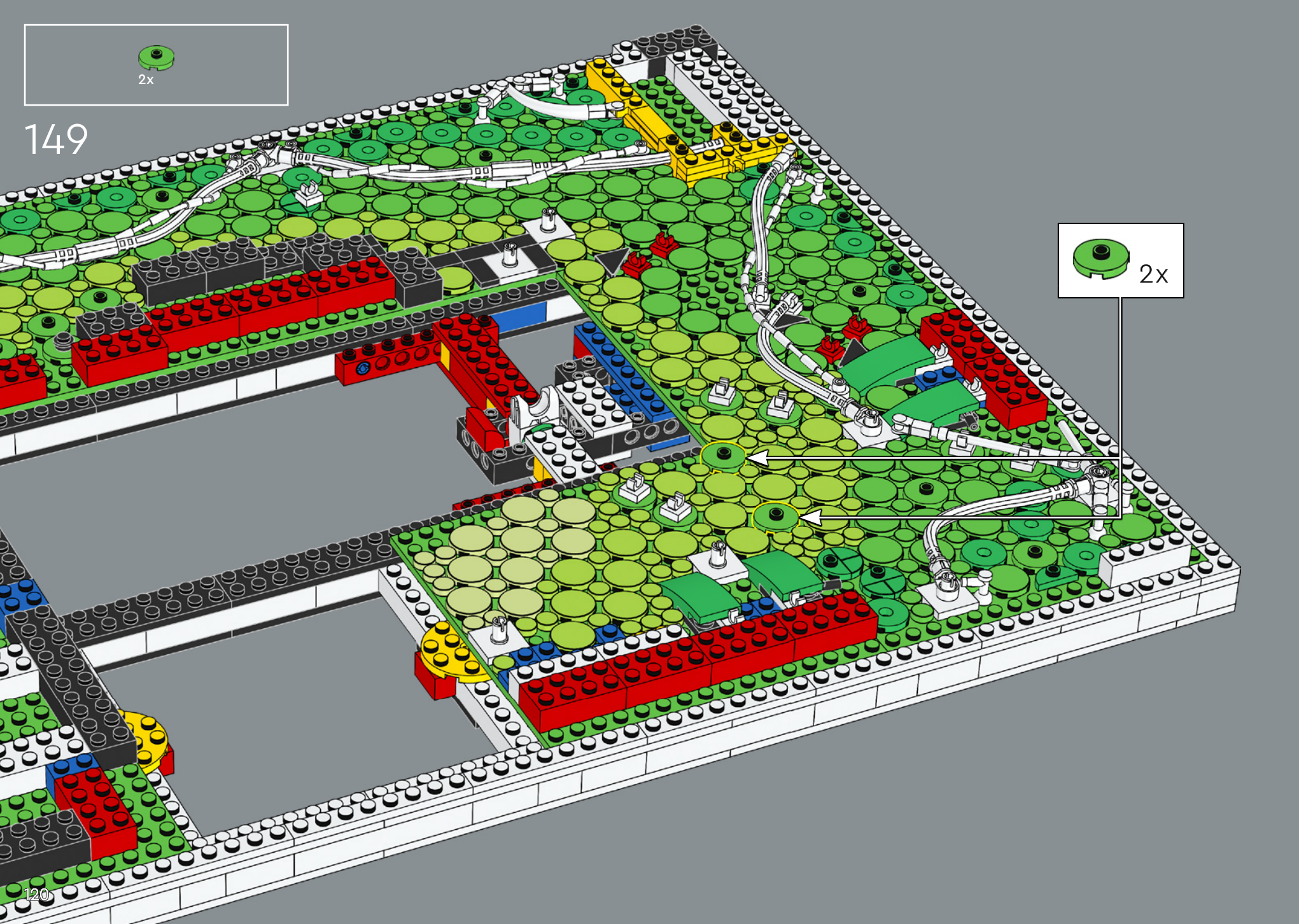



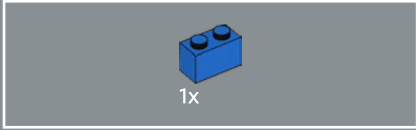
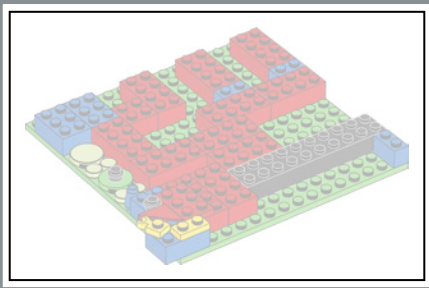

150

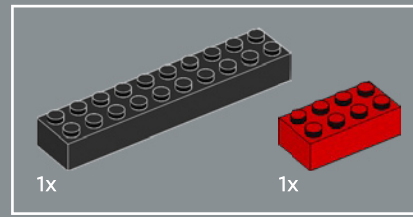
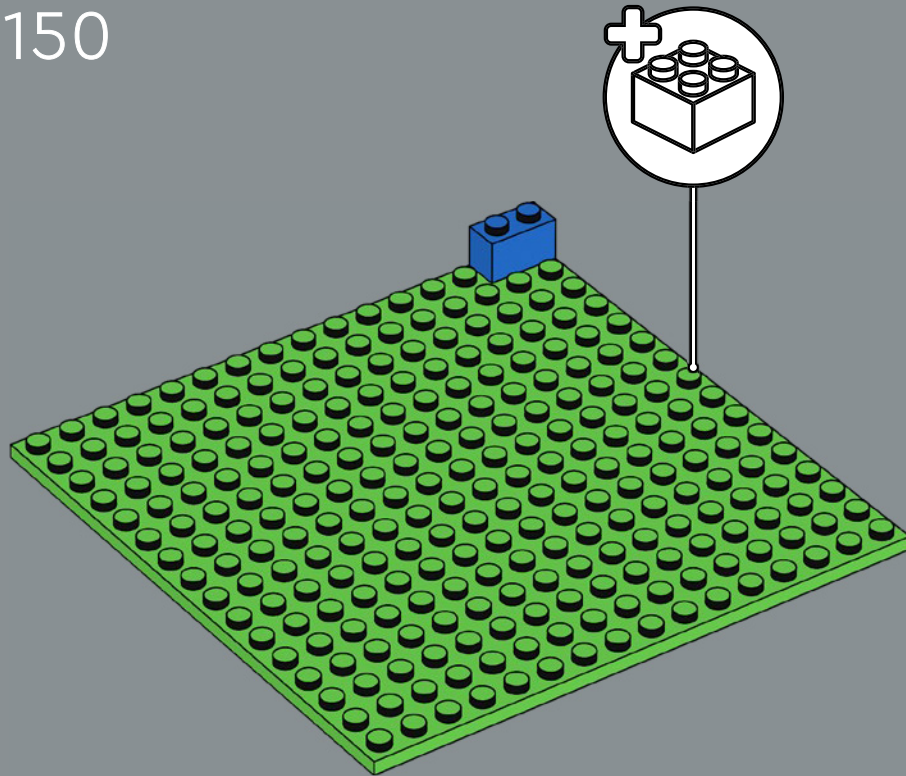

151

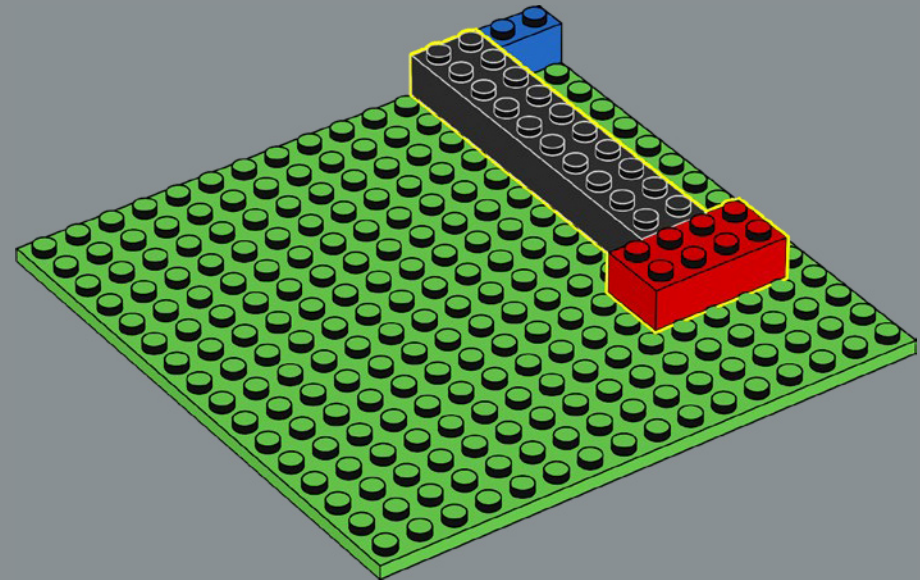

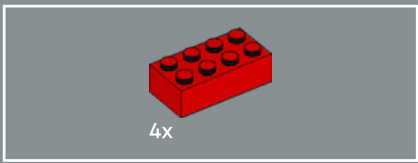

152

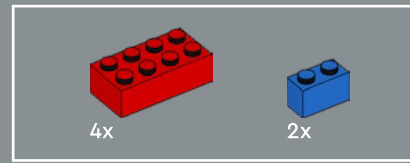
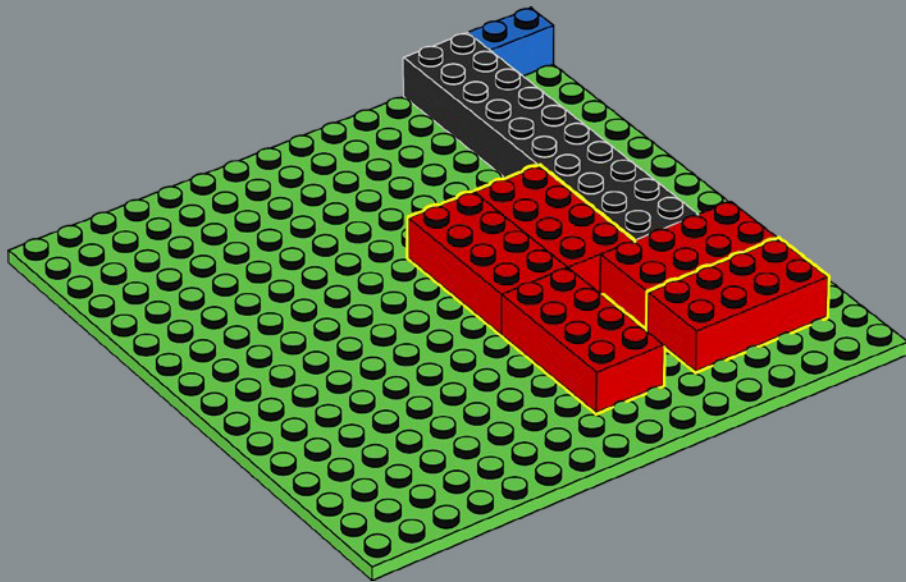

153

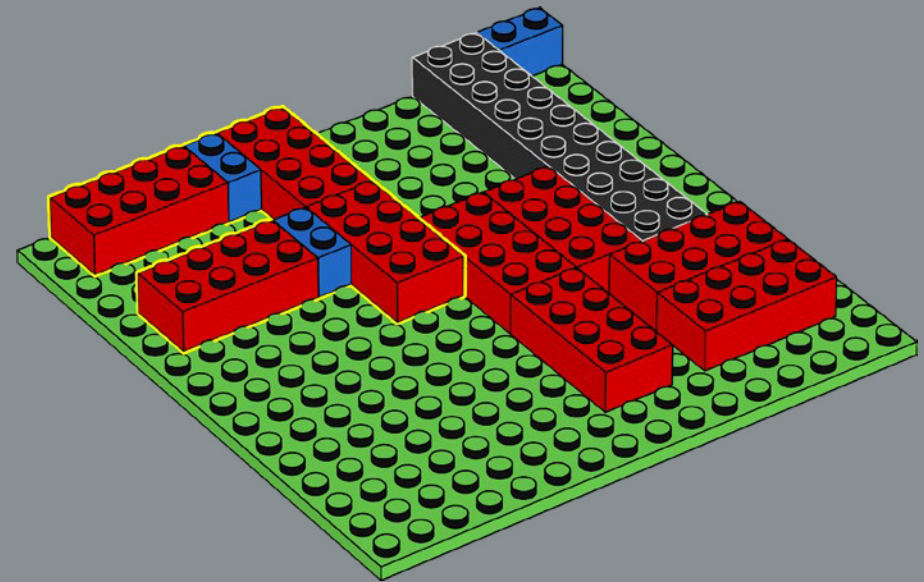

Did you know that the 10294 LEGO® Titanic contains a record amount (40) of iconic red 2x4 bricks? So far, you have placed 35 ...

Saviez-vous que le LEGO® Titanic 10294 contient une quantité record (40) de briques 2x4 rouges emblématiques ? Jusqu'à présent, vous en avez placées 35...

¿Sabías que el Titanic LEGO® (10294) contiene una cantidad récord (40) de los emblemáticos bricks rojos 2x4? Hasta ahora, has colocado 35...

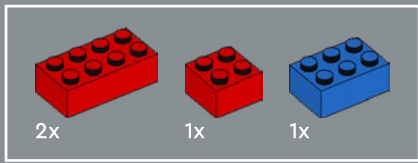

154

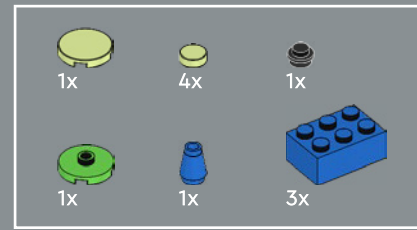
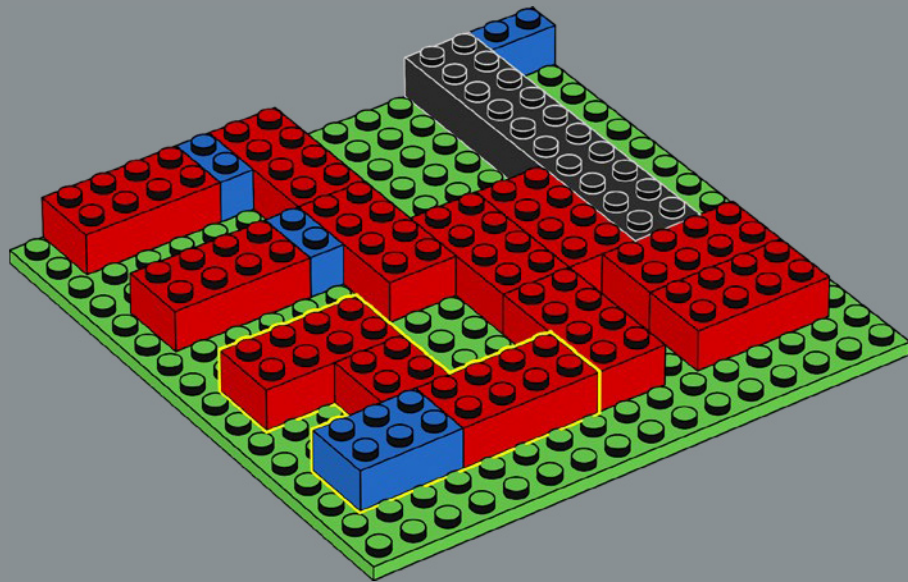

155

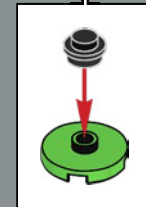
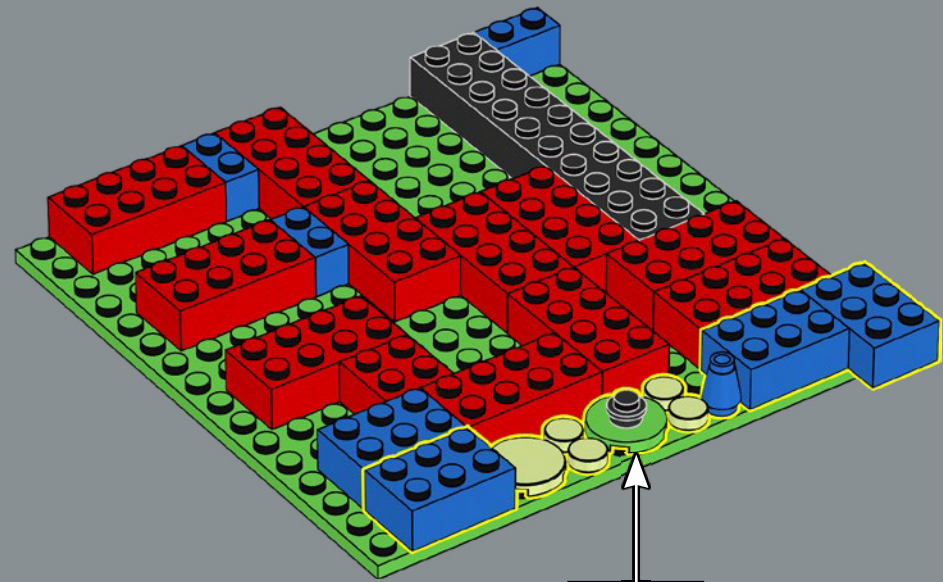

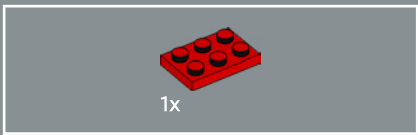

156

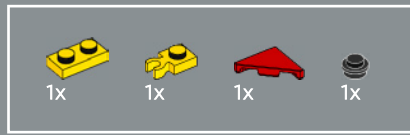
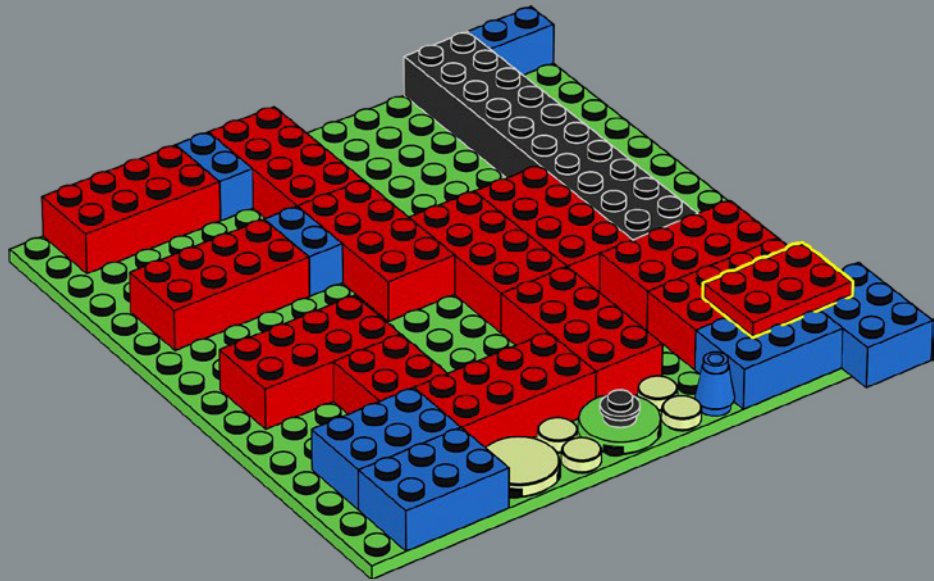

157

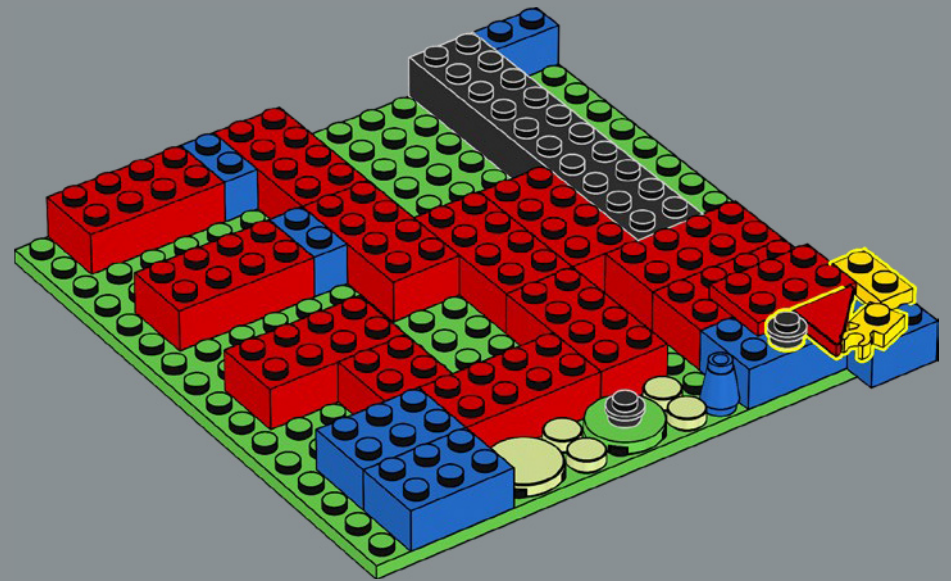

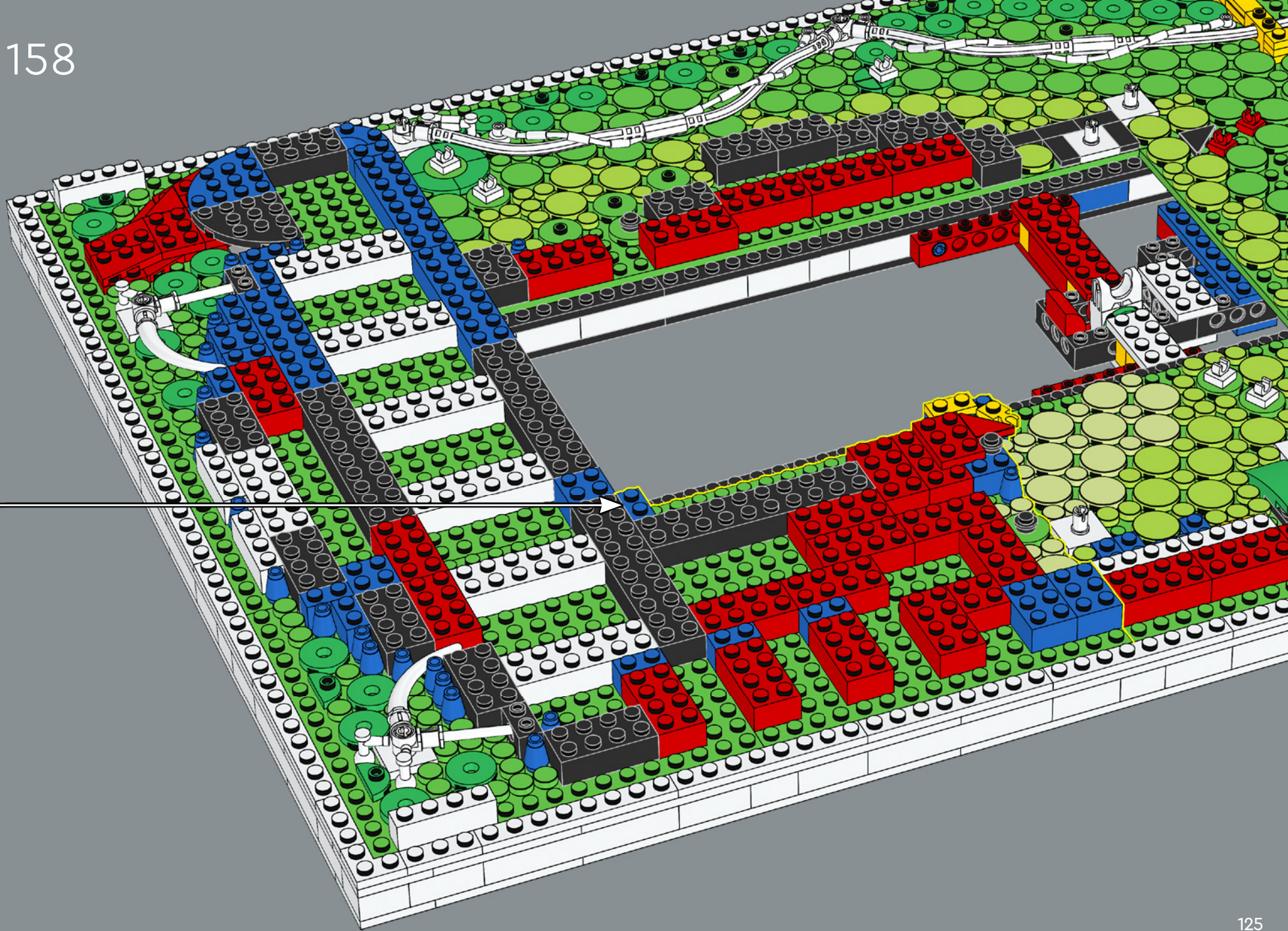

159

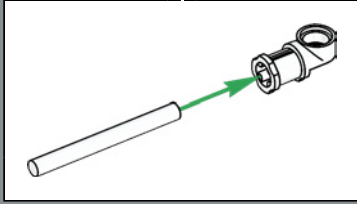
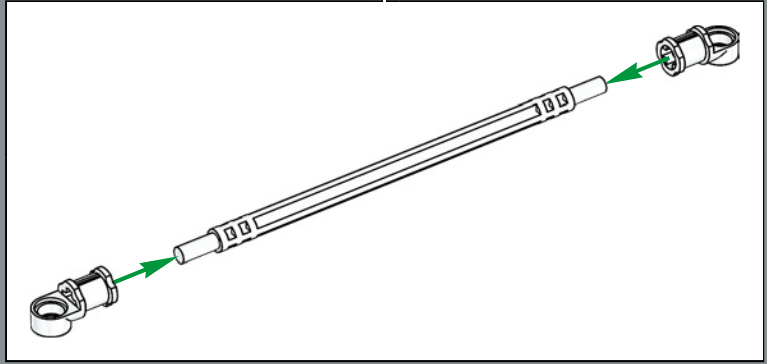
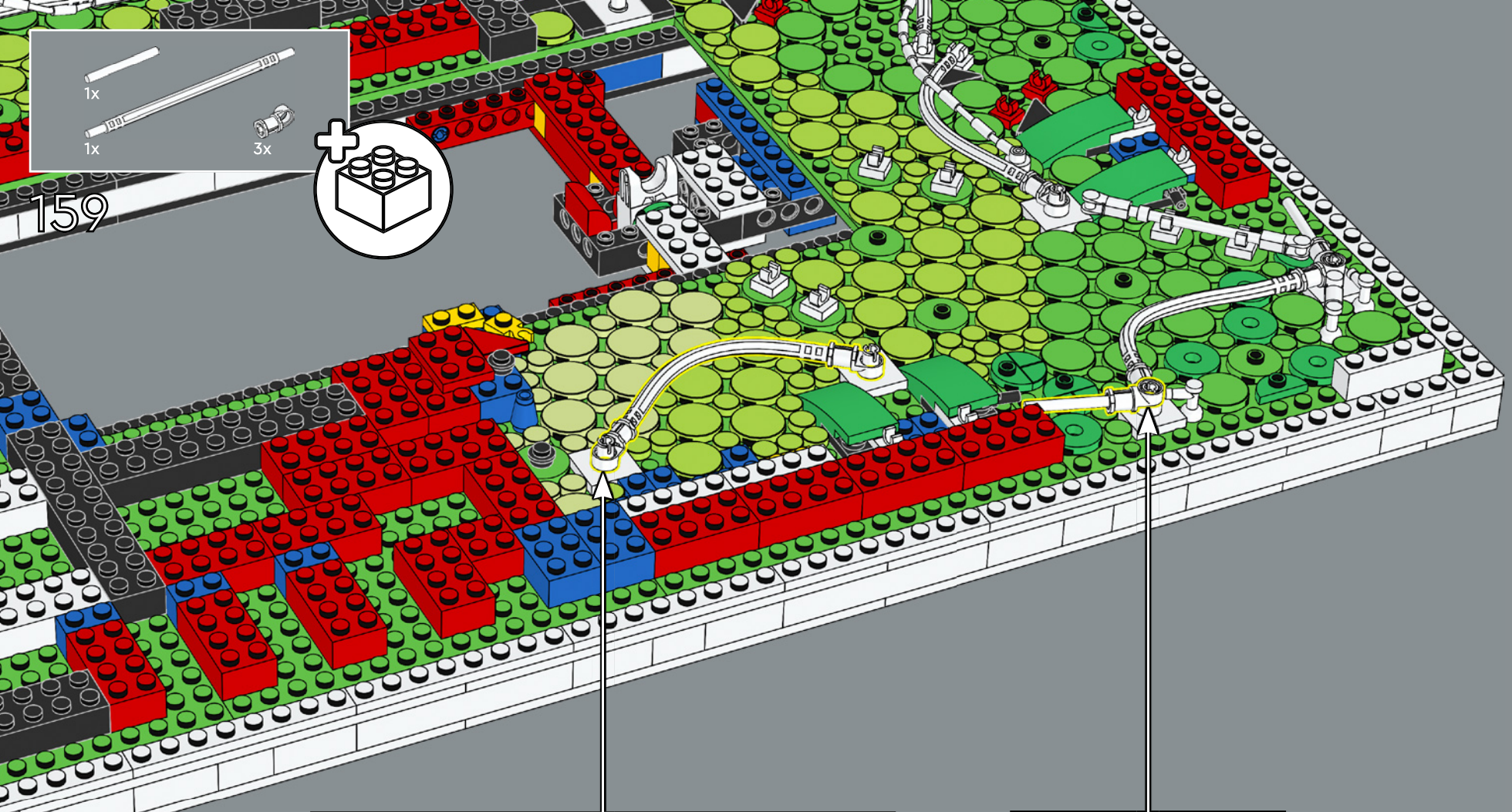
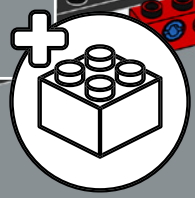

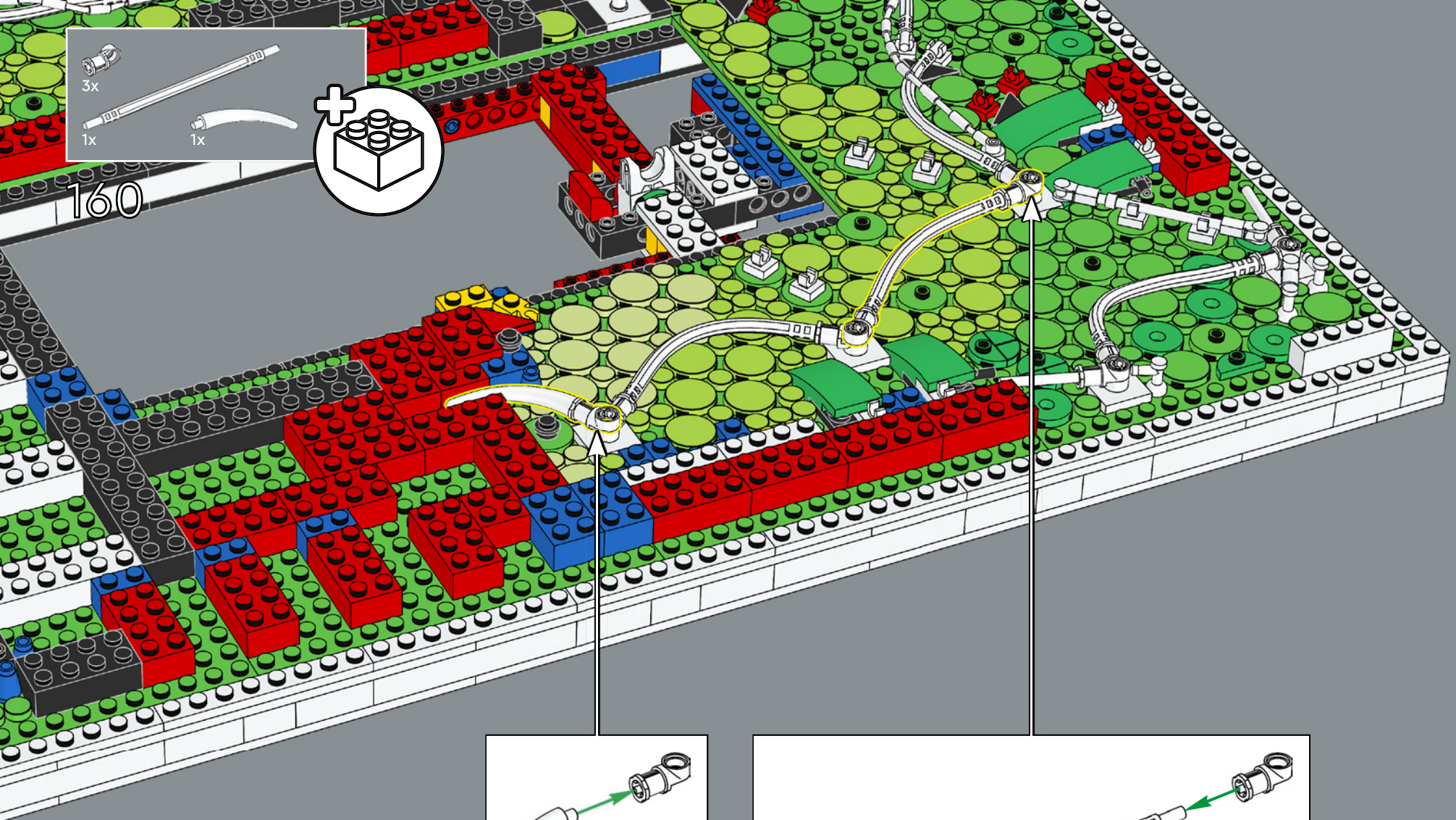

- 3x
- 1x
- 1x

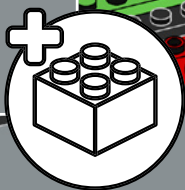

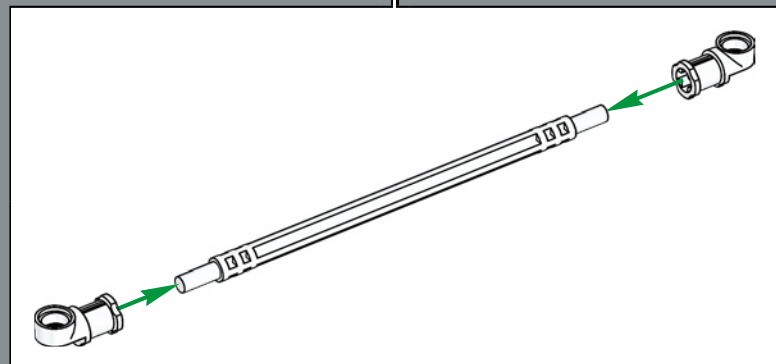
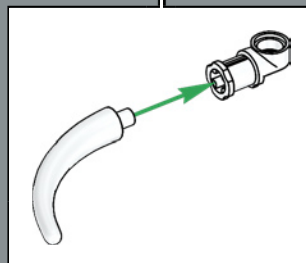

160

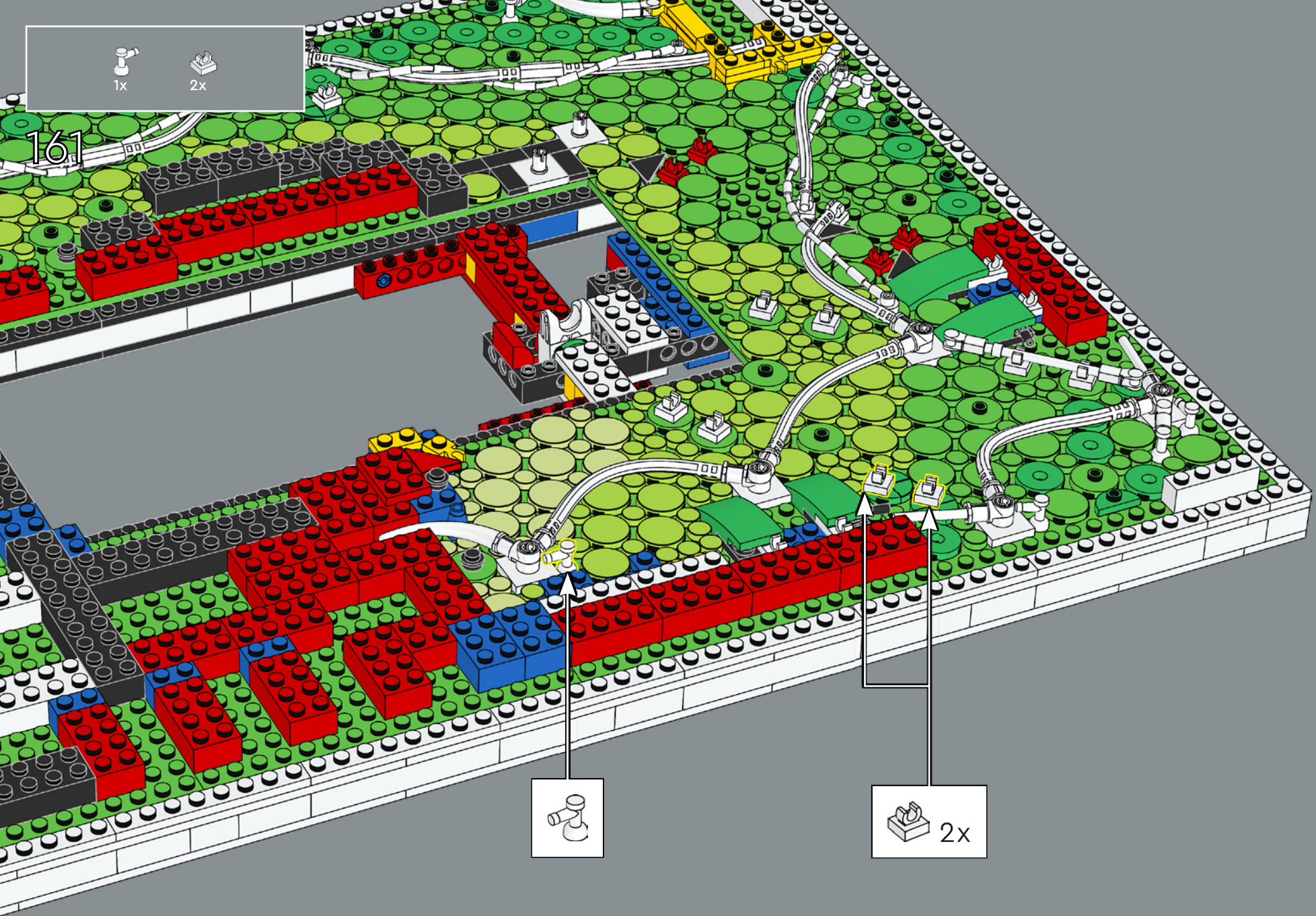

1x  2x 

161





 2x





162

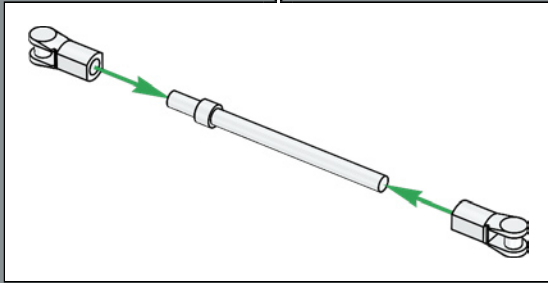
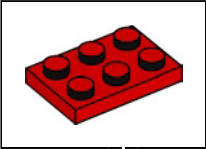

The tensile strength of Spider-Man's web lines has been estimated at around 120 pounds per square millimeter of the cross-section.

La résistance à la traction des lignes des toiles de Spider-Man a été estimée à environ 54,4 kg par millimètre carré de section.

La resistencia a la tracción de las telarañas de Spider-Man se ha estimado en unos 54 kg por mm<sup>2</sup> de sección transversal.

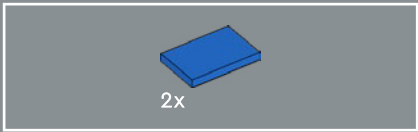

163

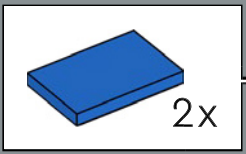
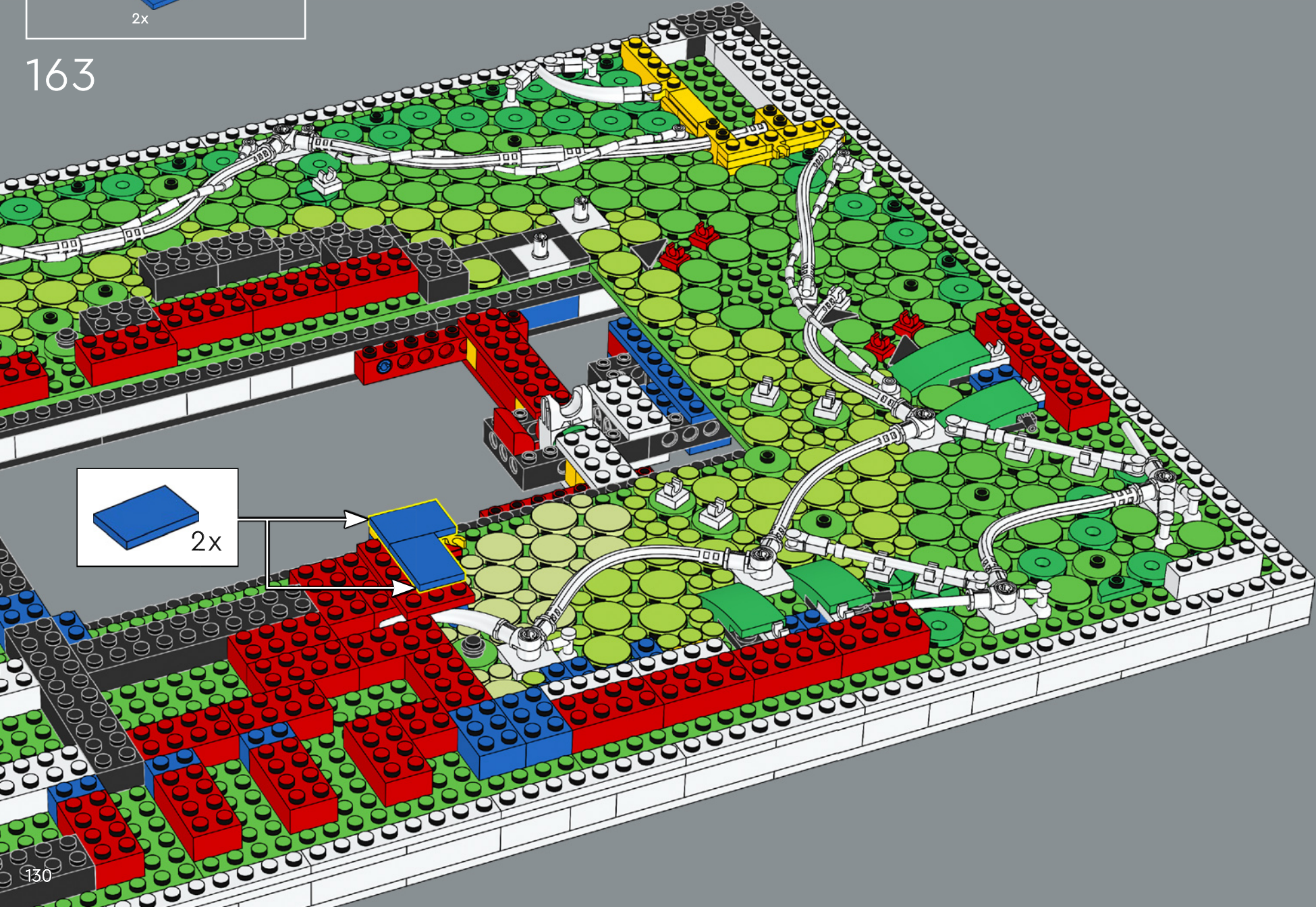



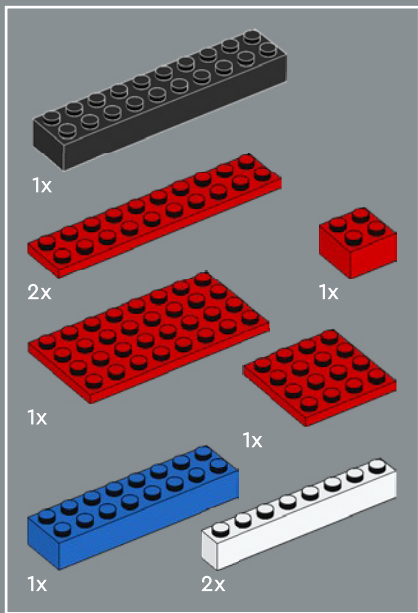

164

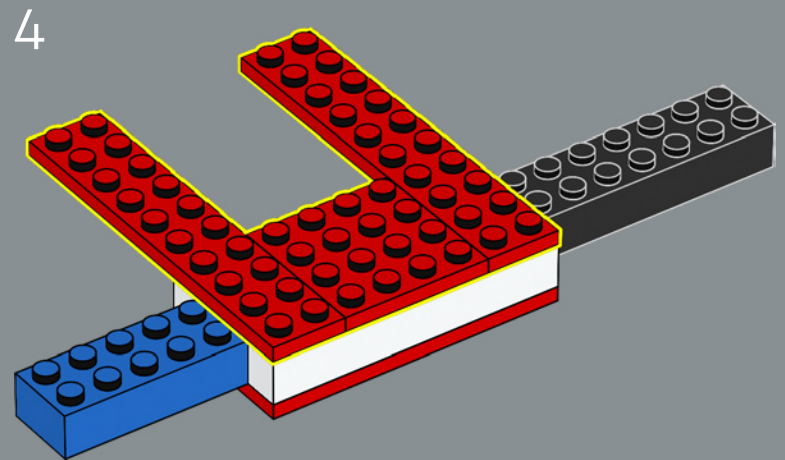
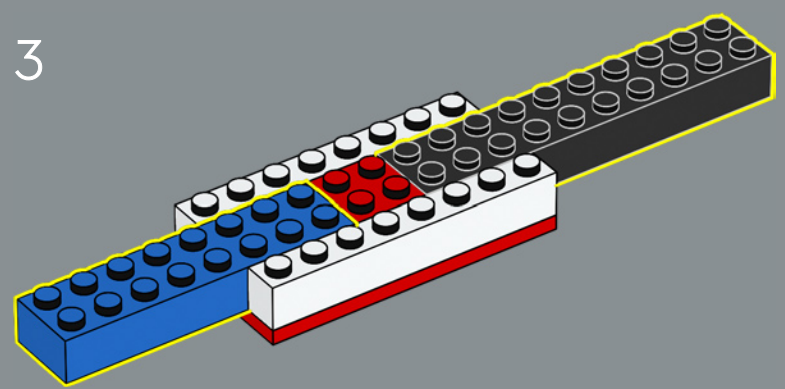
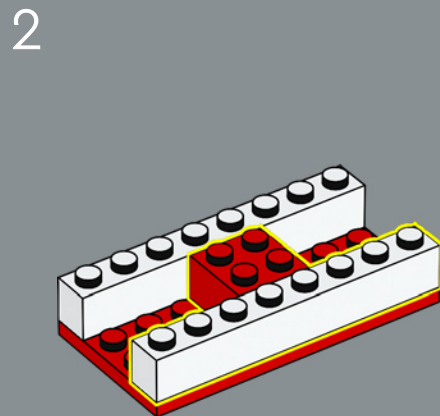
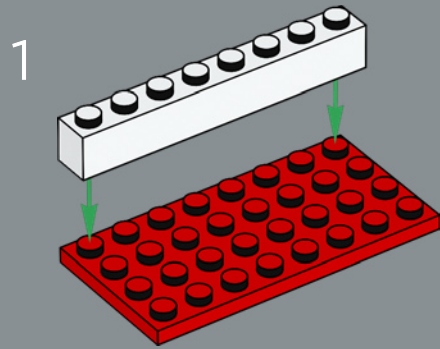



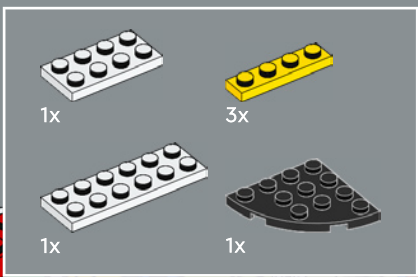

165



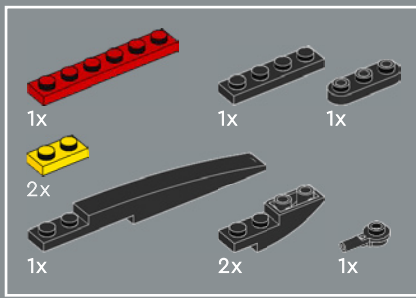

166

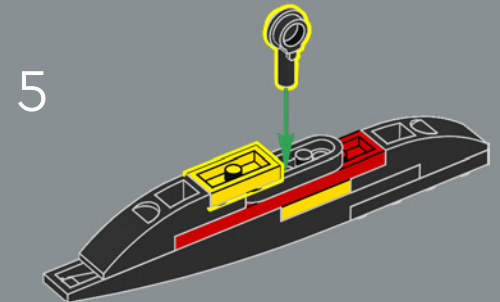
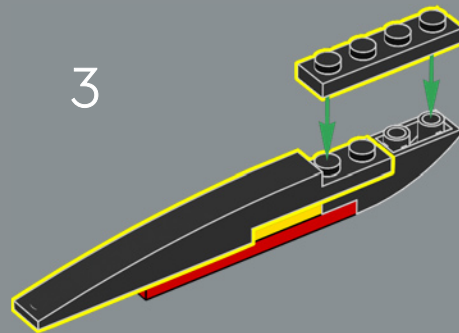
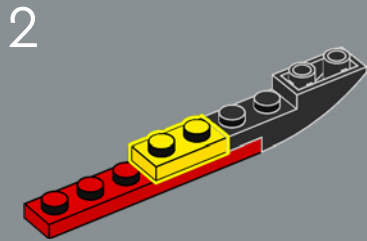
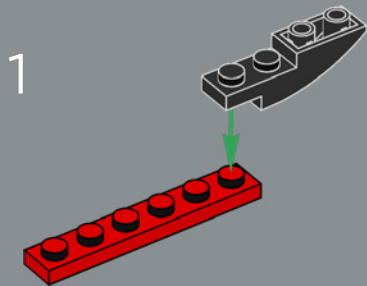

When blue becomes yellow, suddenly this section evokes the costume of Jessica Drew aka Spider-Woman, who first appeared in Marvel Spotlight #32 from 1977!

Lorsque le bleu devient jaune, cette section évoque soudainement le costume de Jessica Drew alias Spider-Woman, qui est apparue pour la première fois dans le magazine Marvel #32 de 1977 !

Cuando el azul se convierte en amarillo, esta sección evoca de pronto el traje de Jessica Drew, alias Spider-Woman, ¡que apareció por primera vez en el n.º 32 de Marvel Spotlight, de 1977!

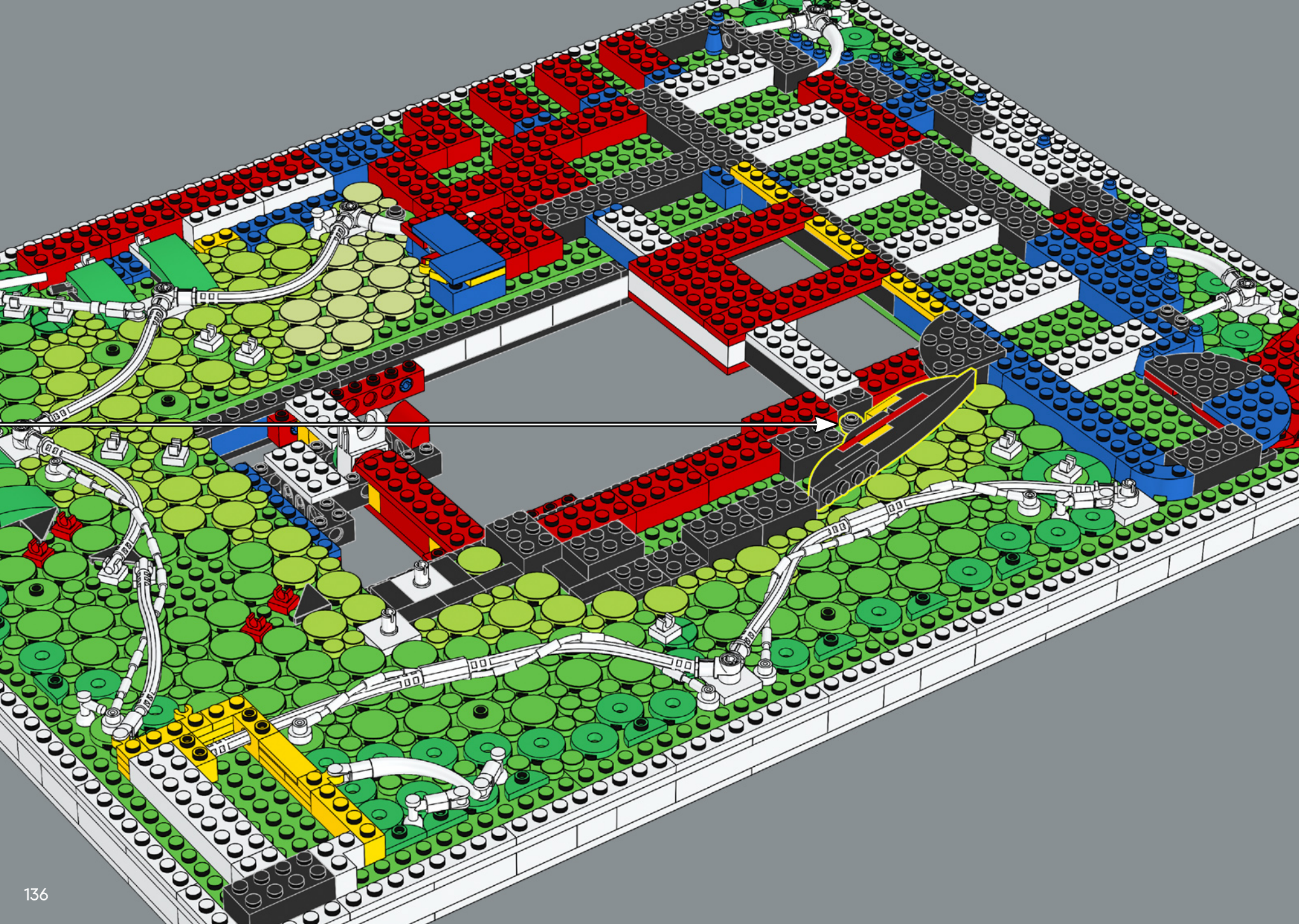



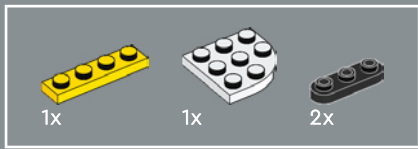

167

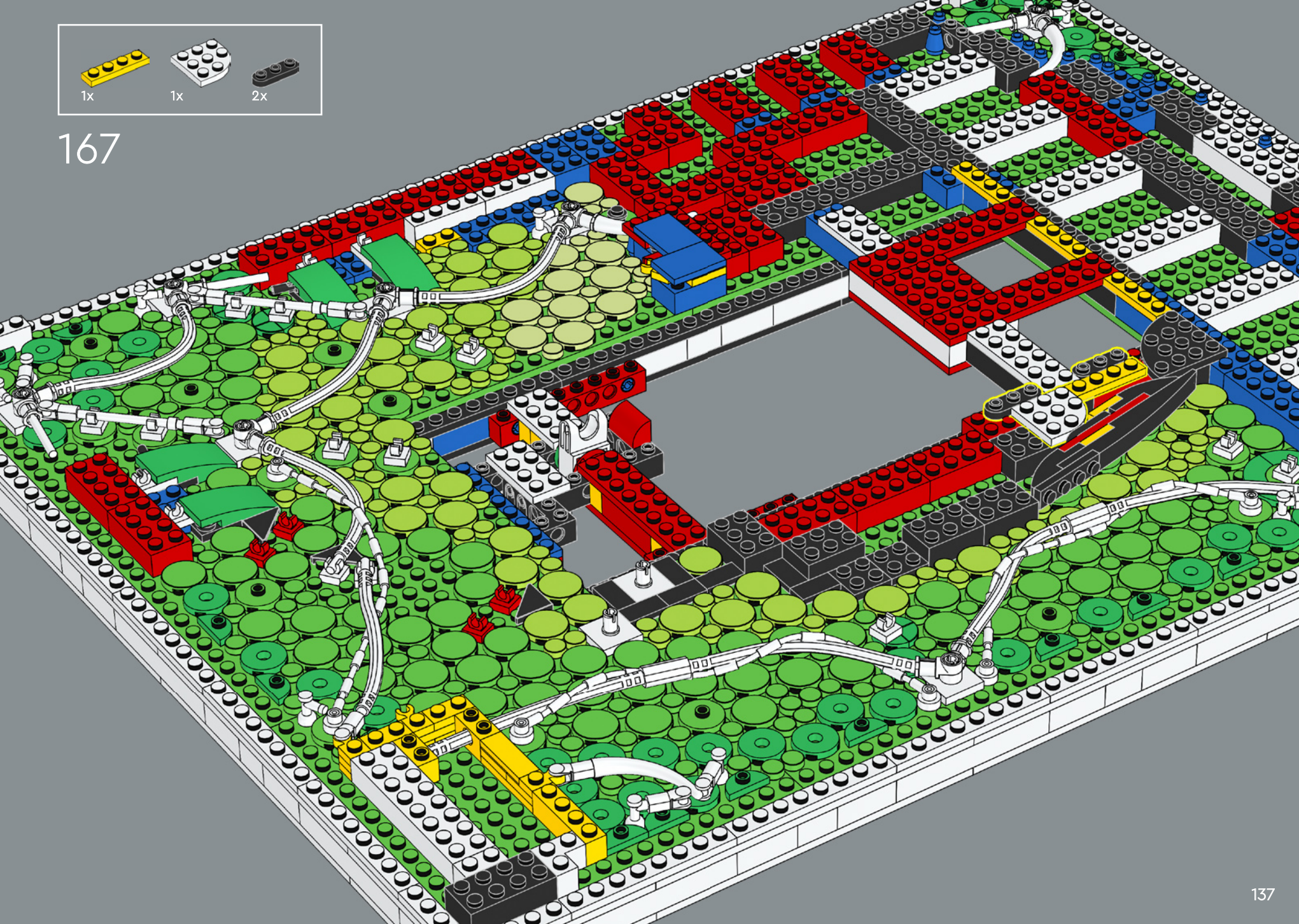

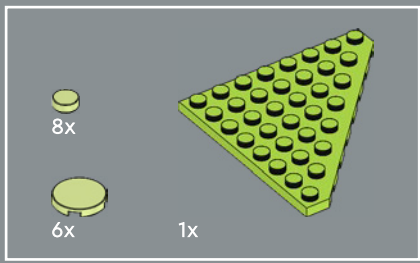

168

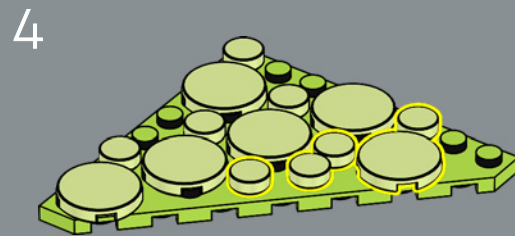
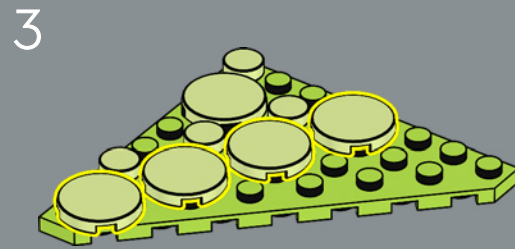
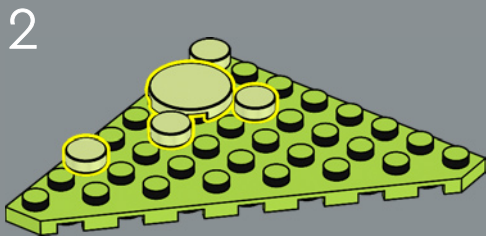
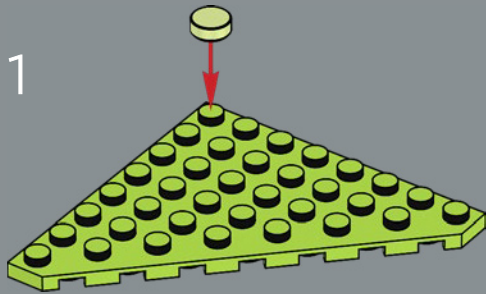

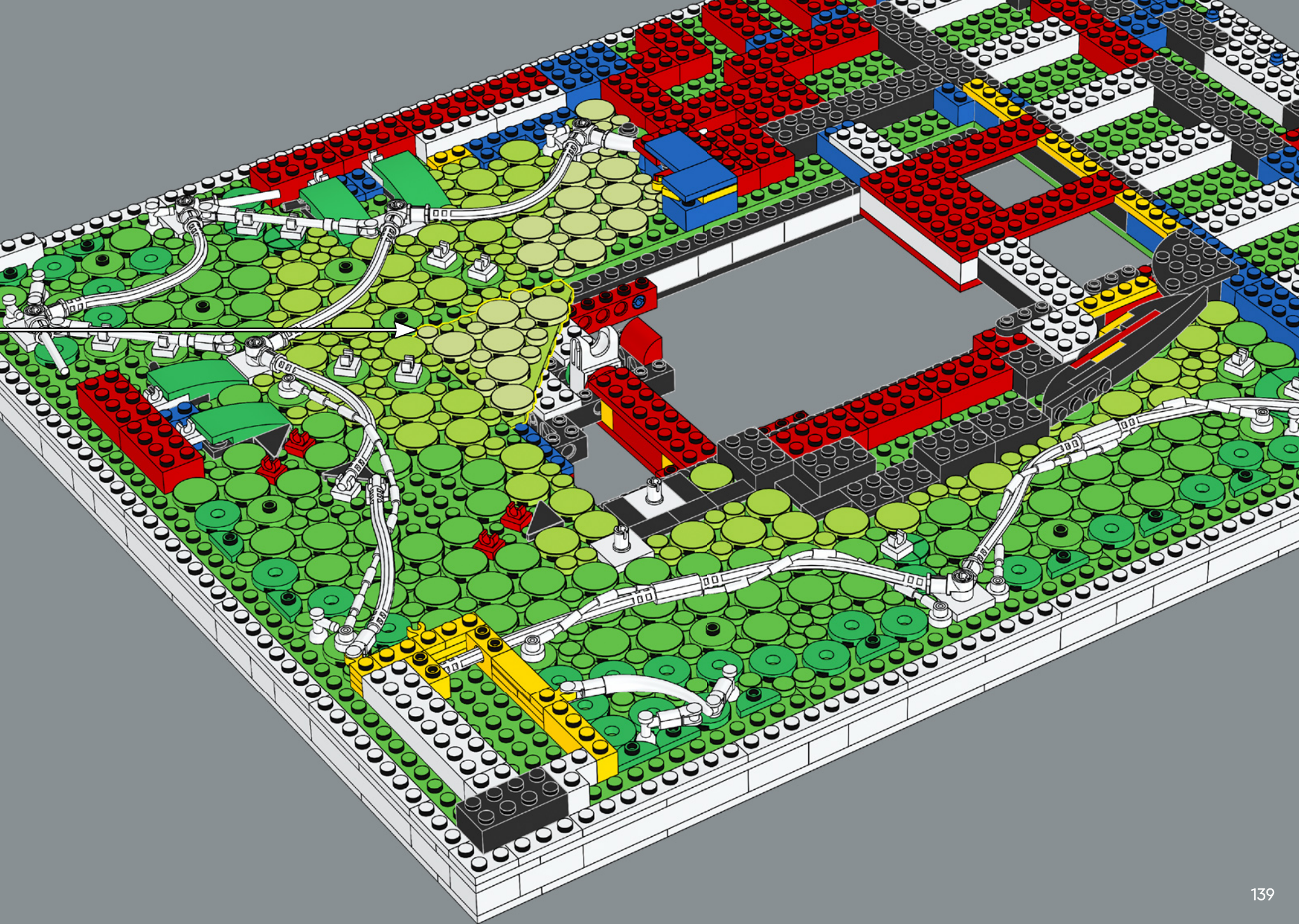

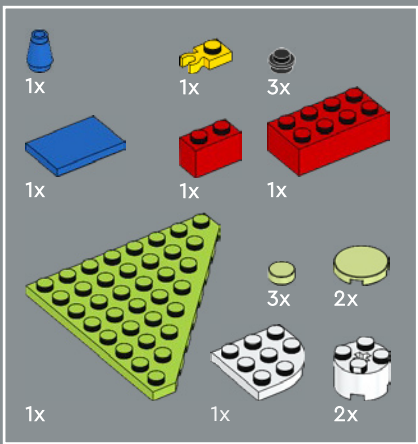

169

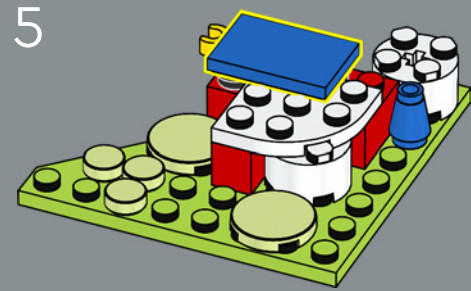
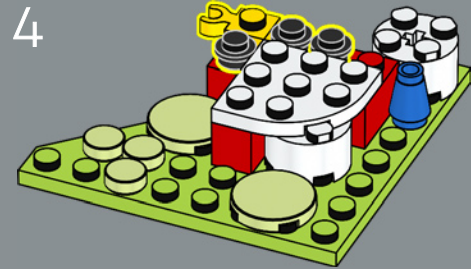
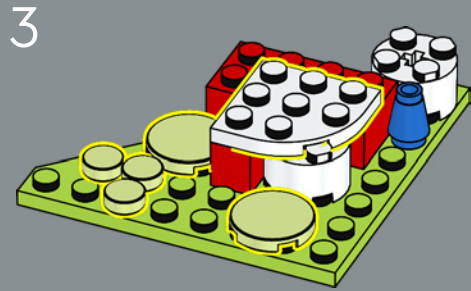
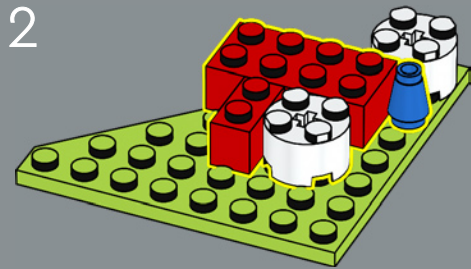
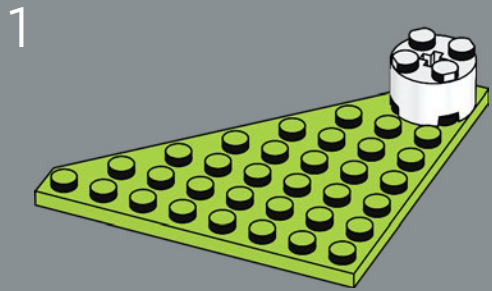

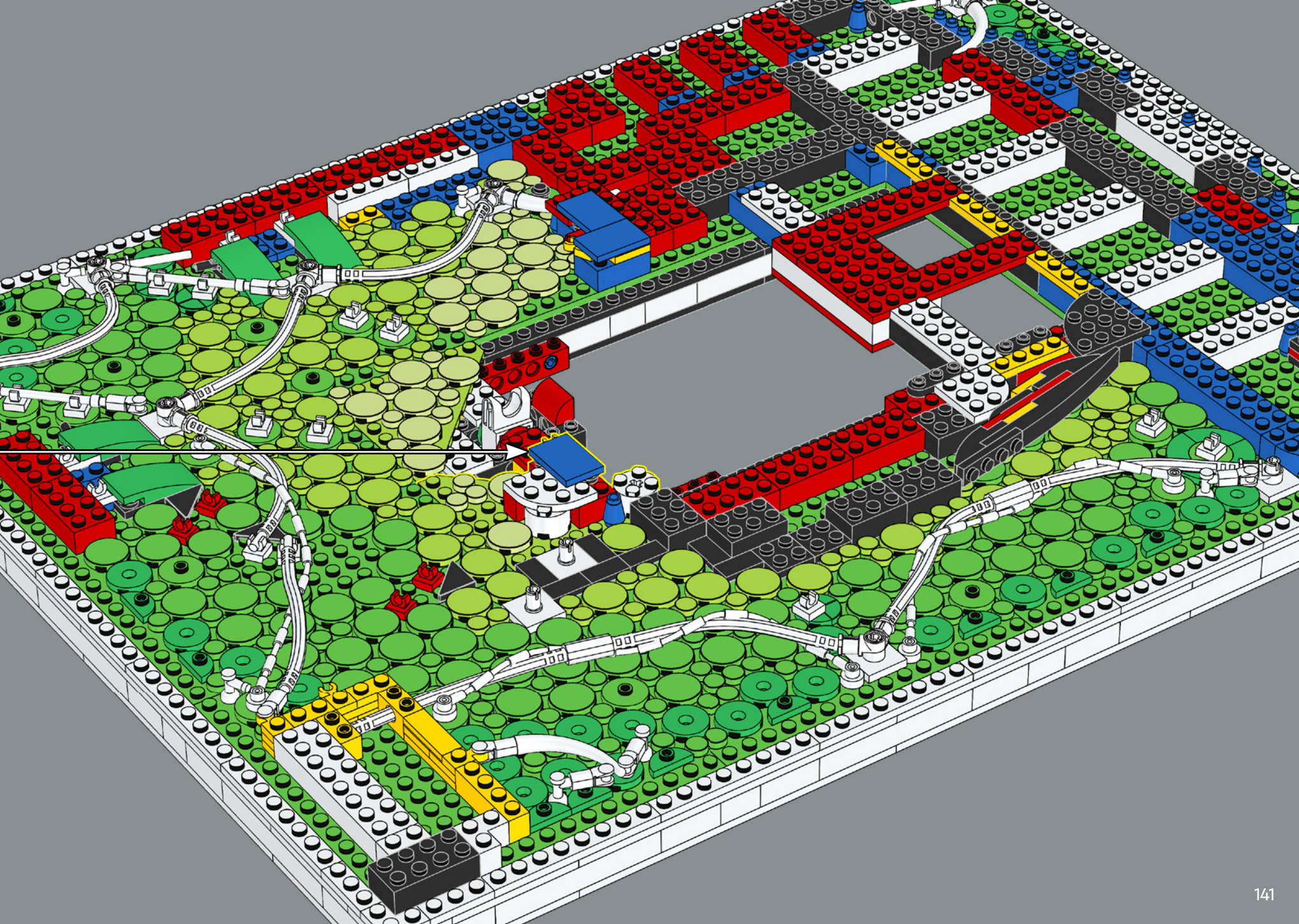



4x

170



4x

142



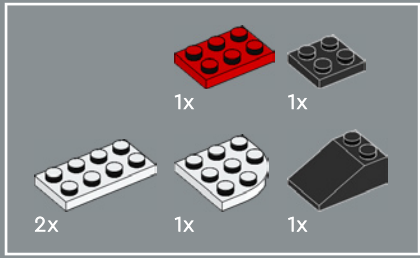

171

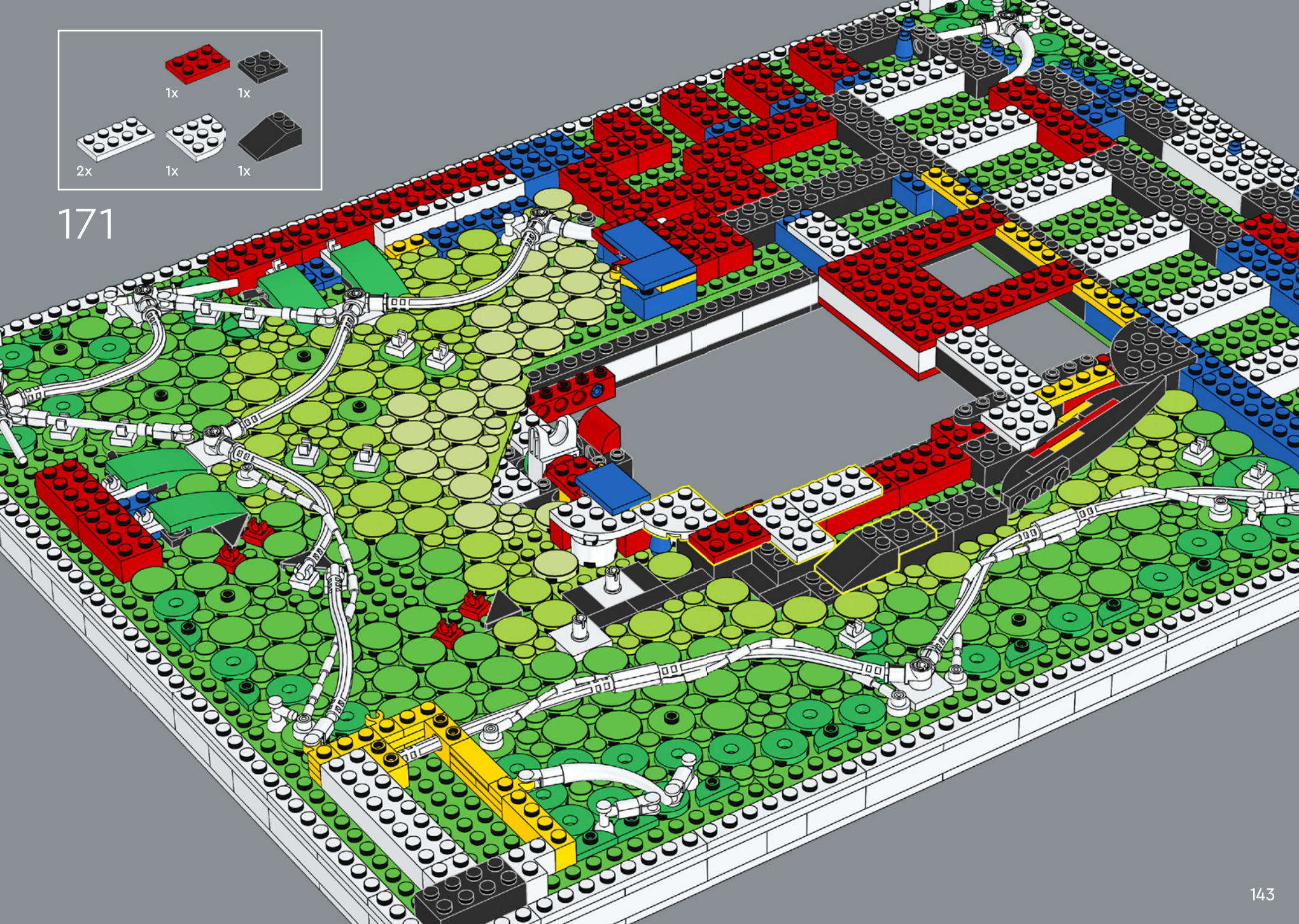

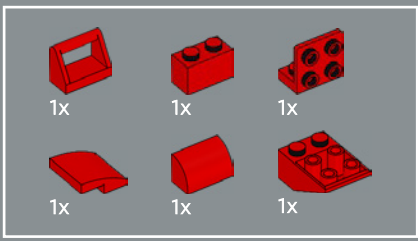

172

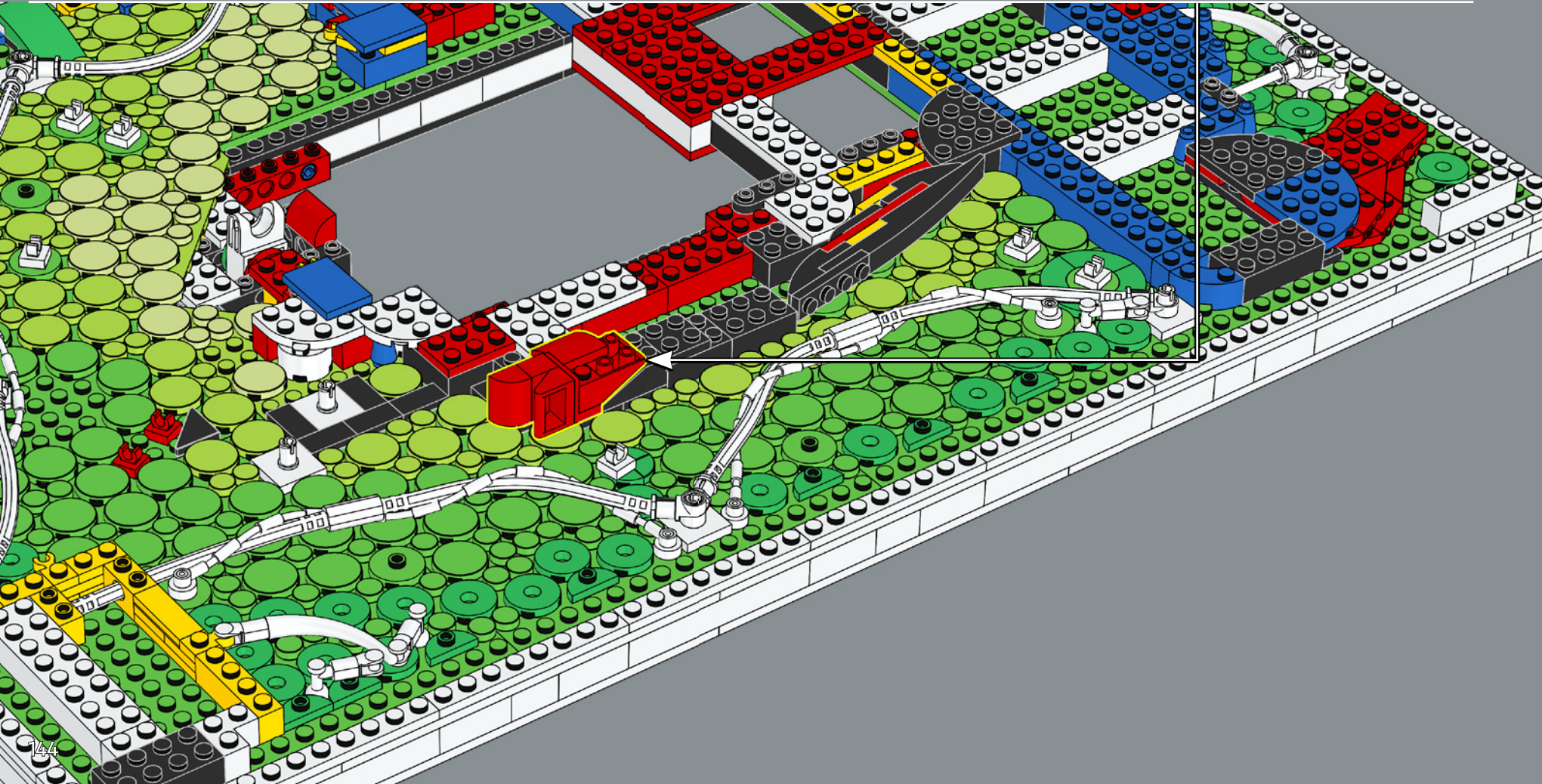
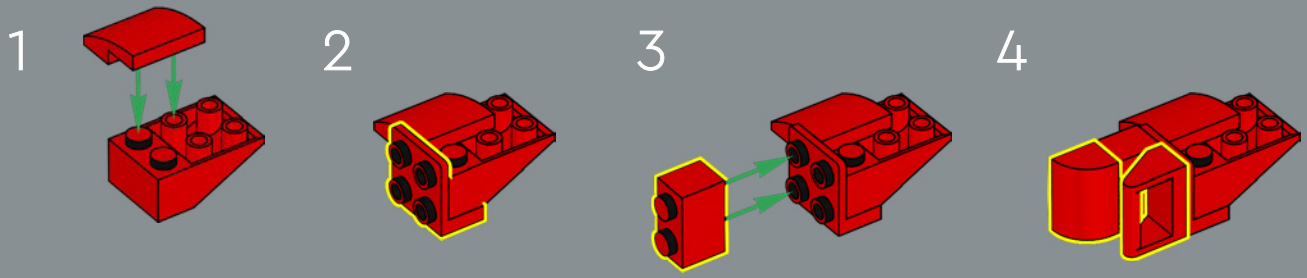



3x  1x 

173

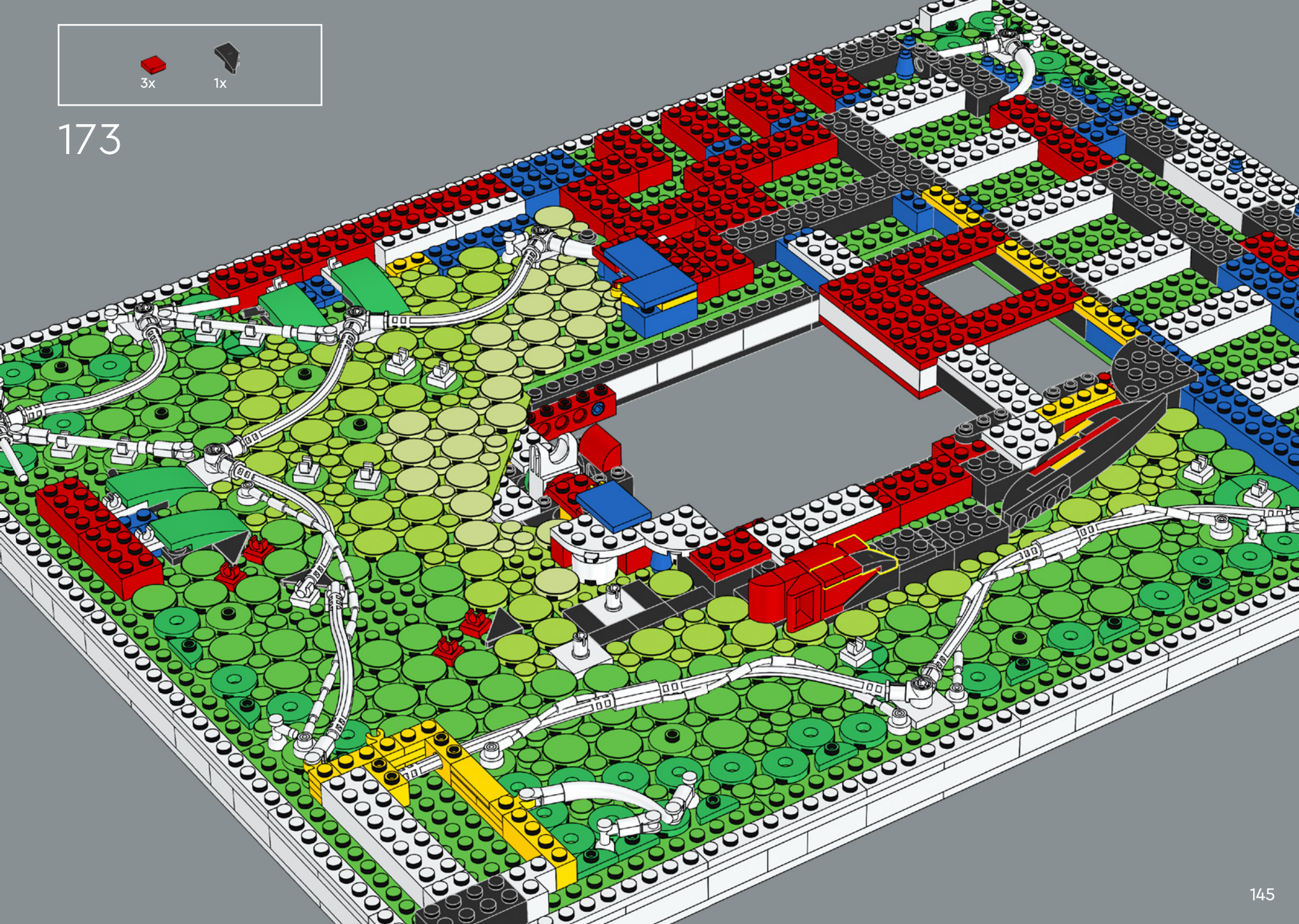

- 2x 
- 3x 

174

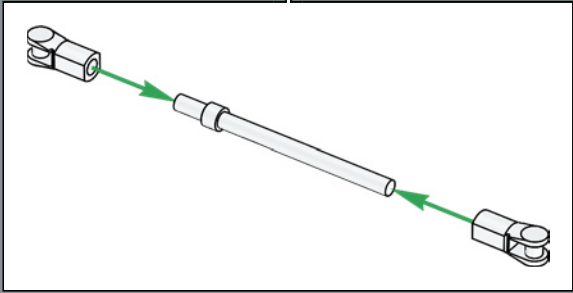
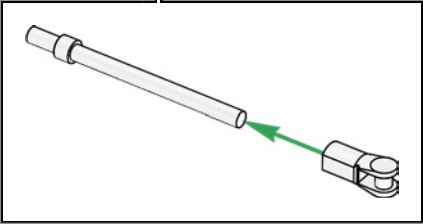
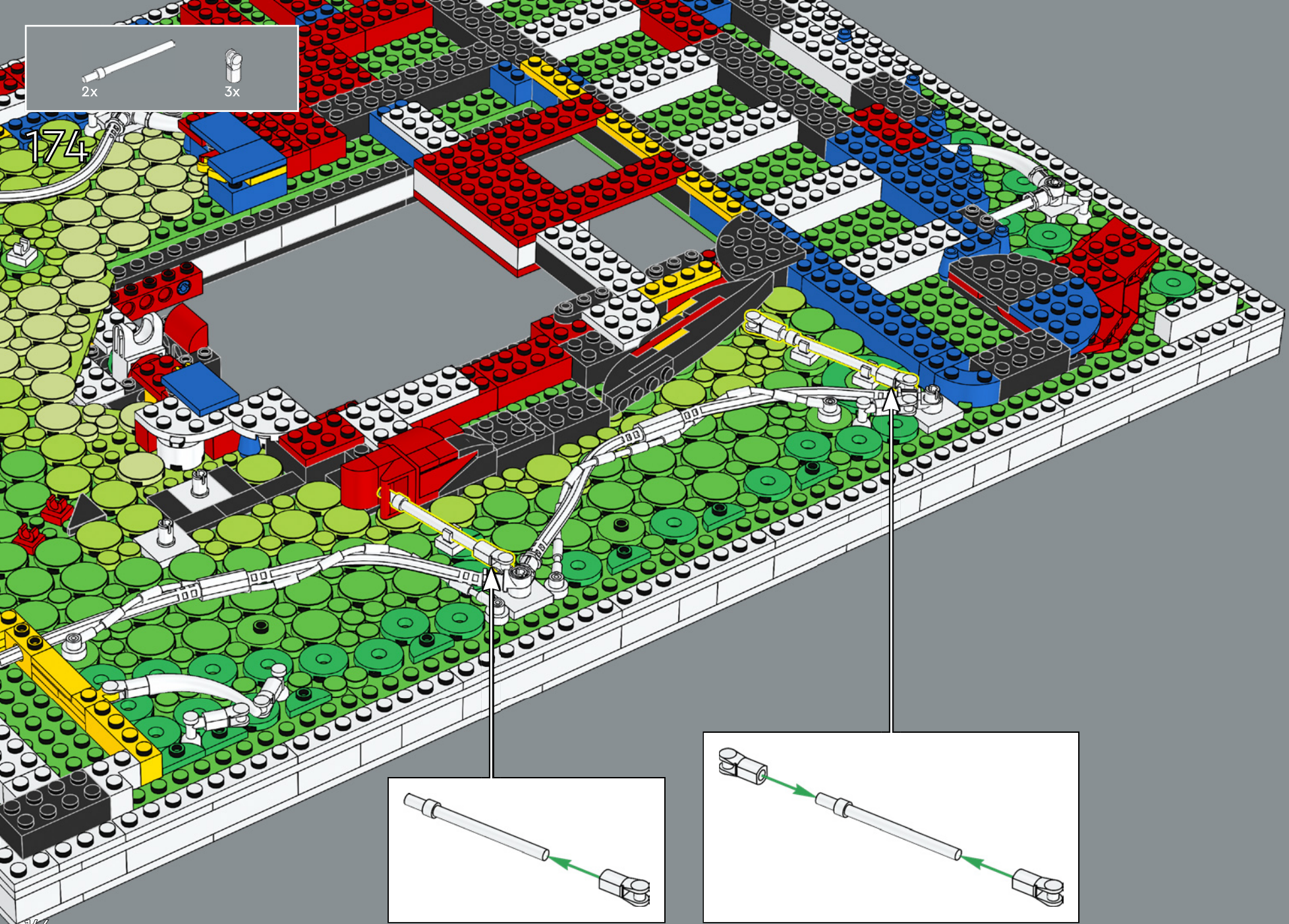

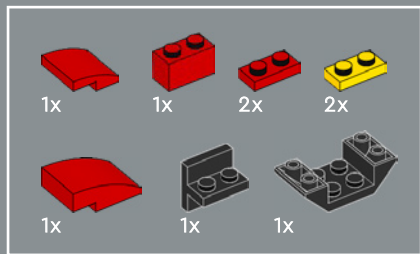

175

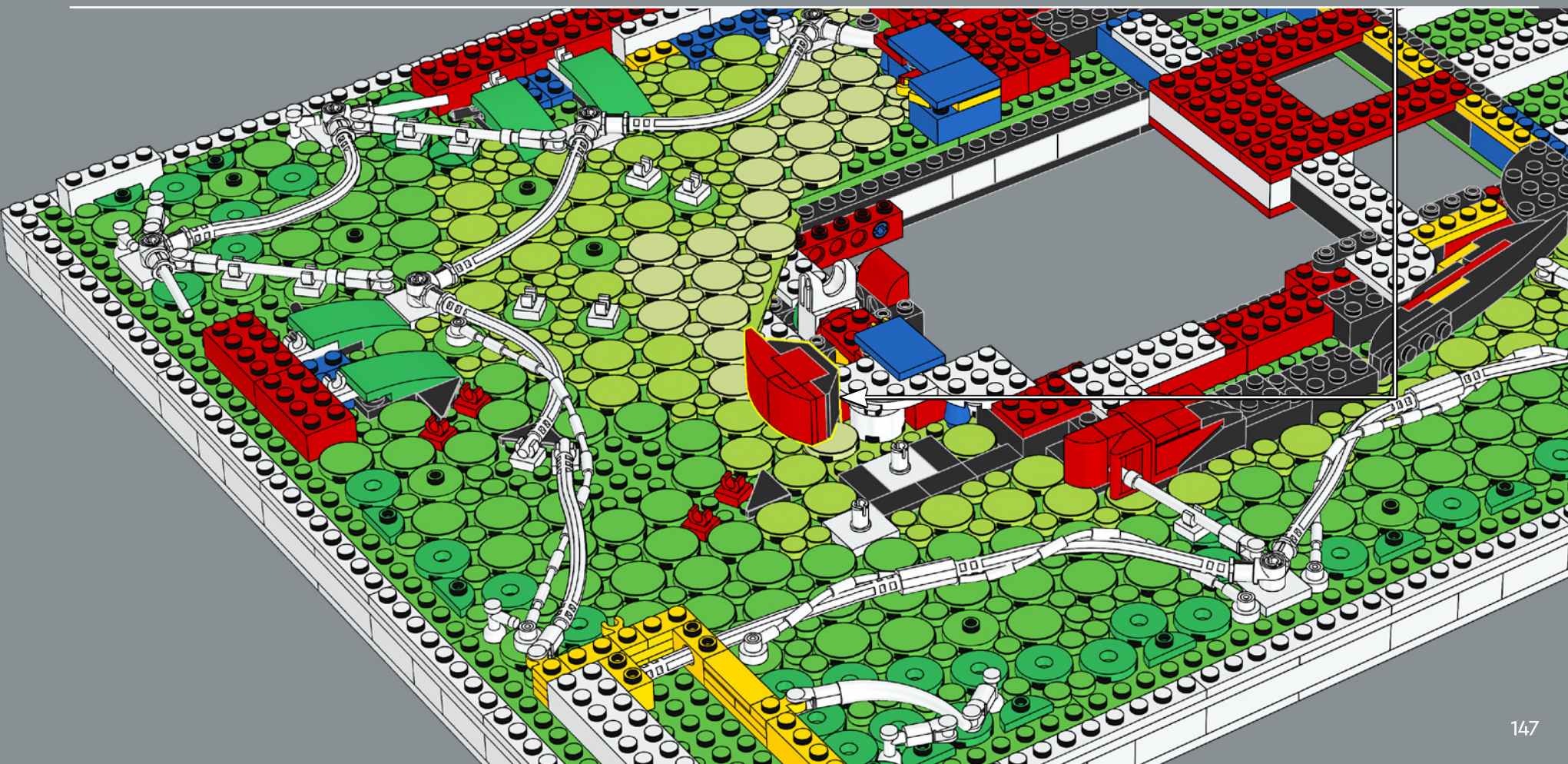
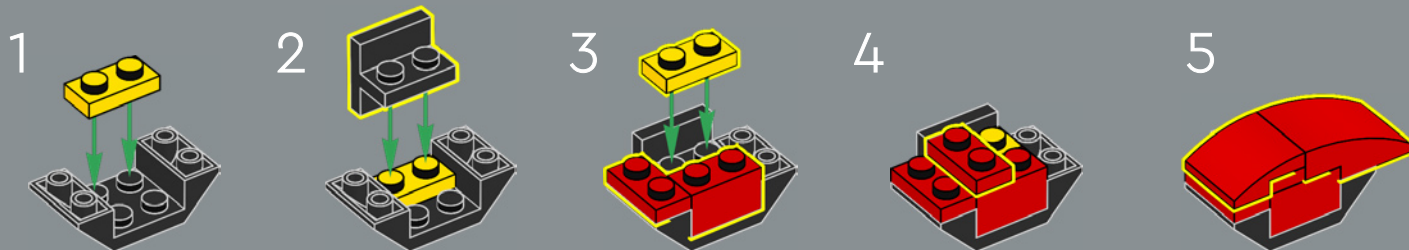

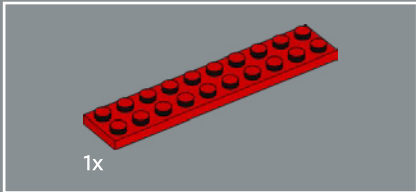
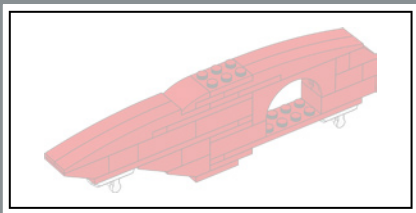

176

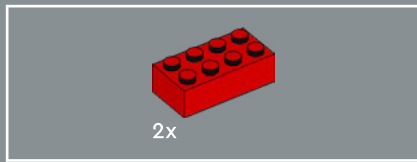
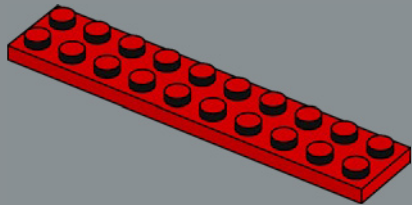

177

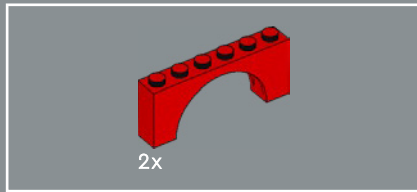
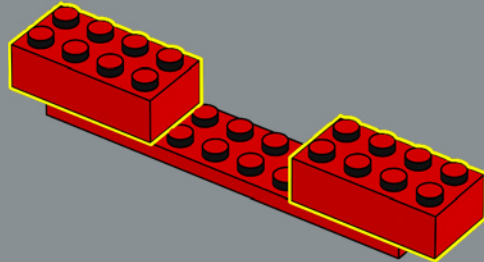

178

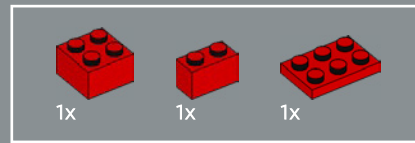
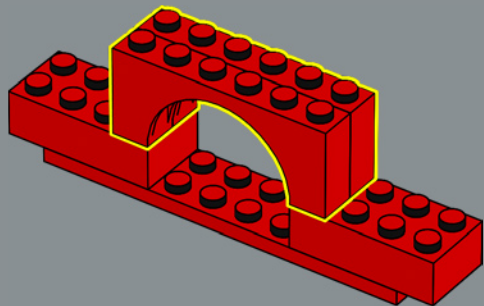

179

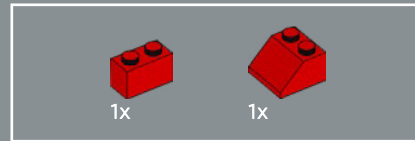
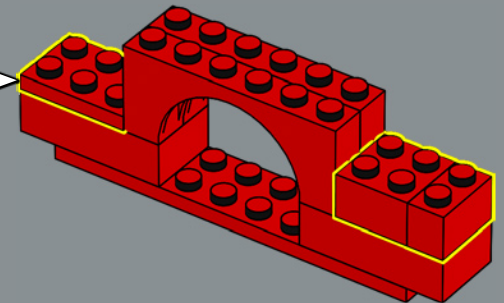
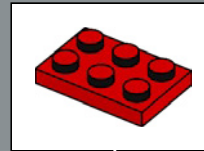

180

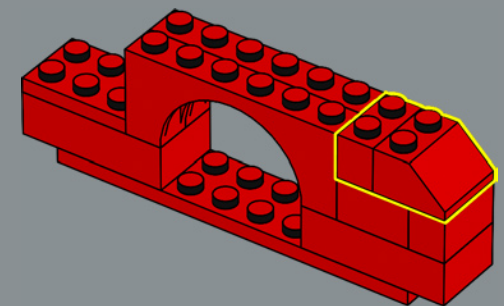

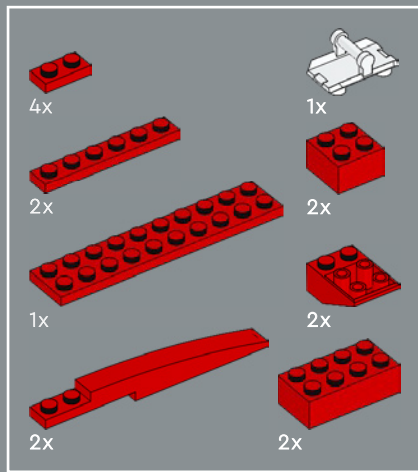

181

1

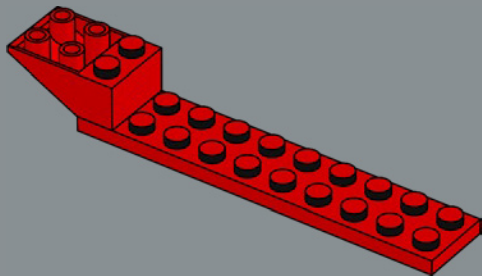

This is the 42<sup>nd</sup> red 2x4 brick you have placed in this model!

C'est la 42<sup>e</sup> brique 2x4 rouge que vous avez placée dans ce modèle !

¡Este es el brick rojo 2x4 número 42 que colocas en este modelo!

2

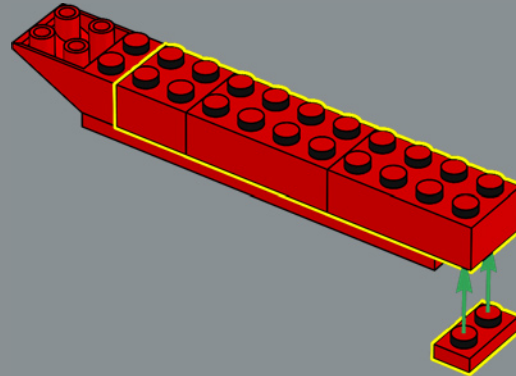

3

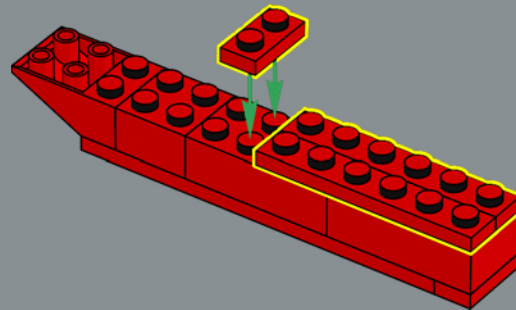

4

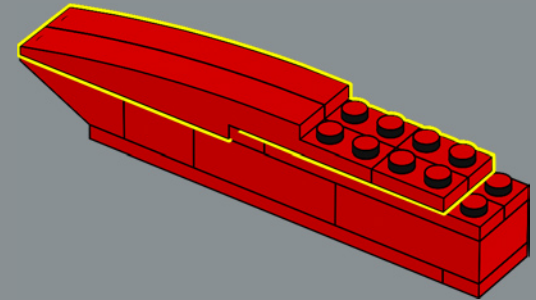

5

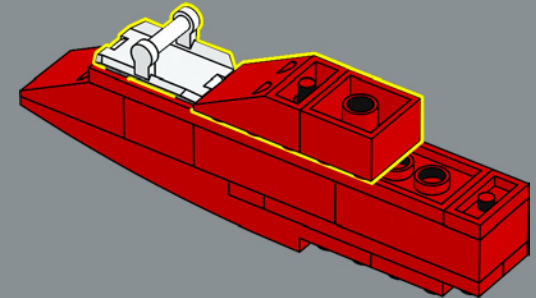

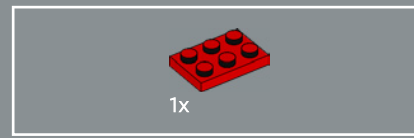
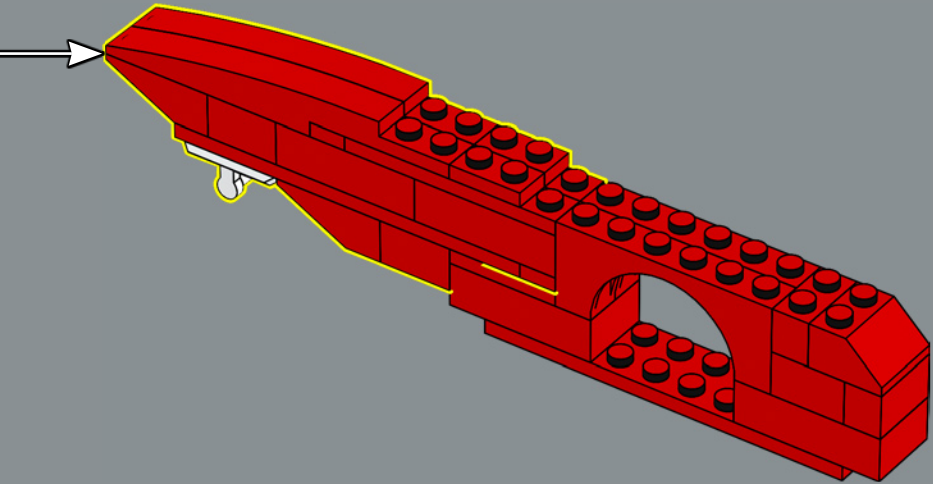

182

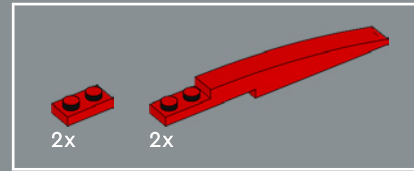
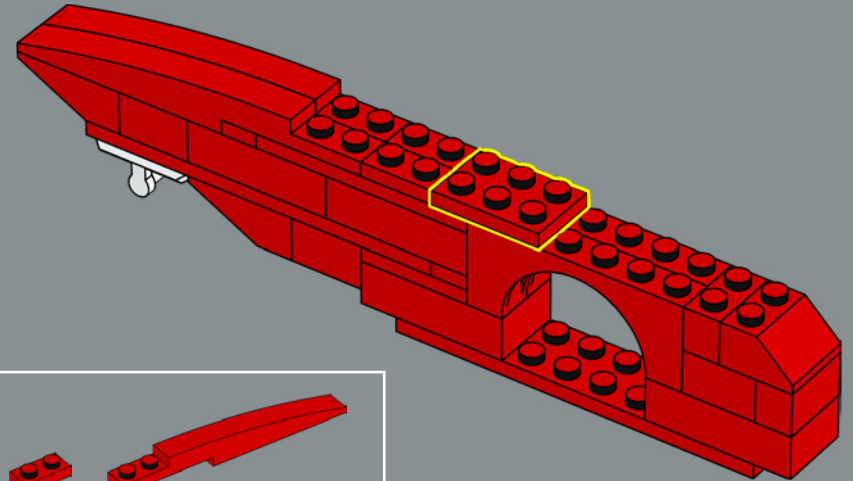

183

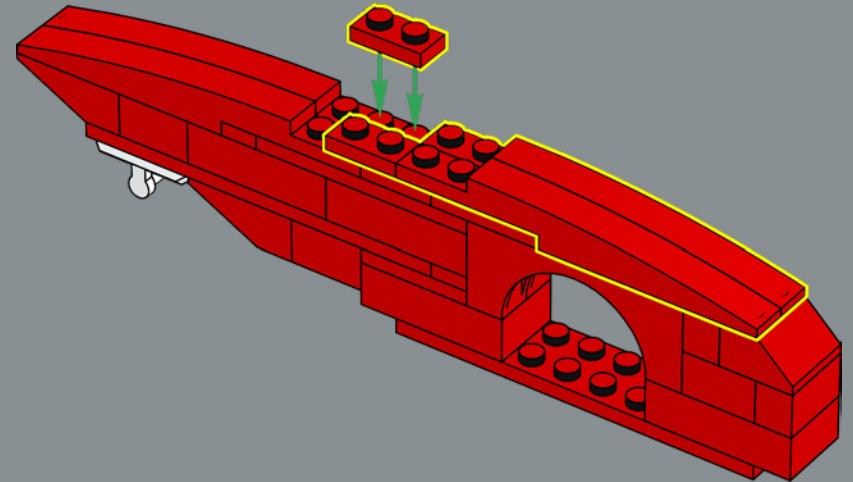

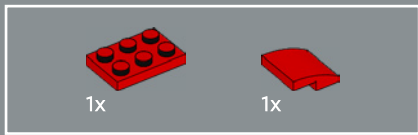

184

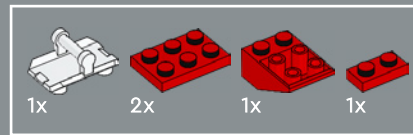
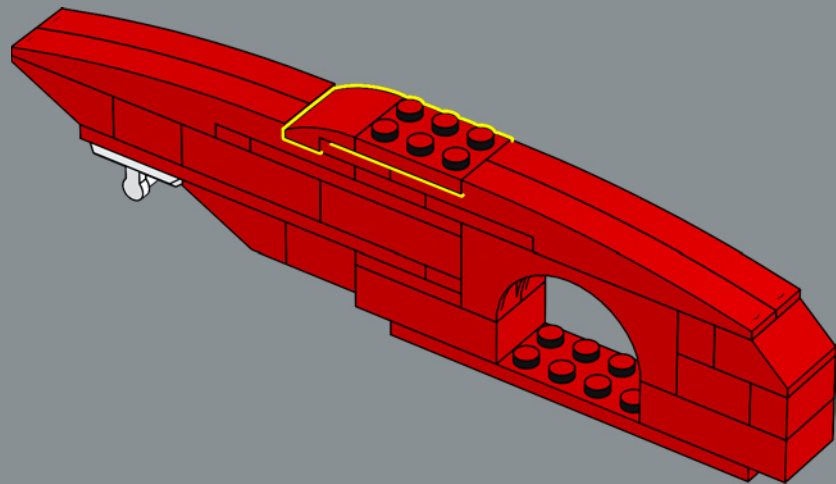

185

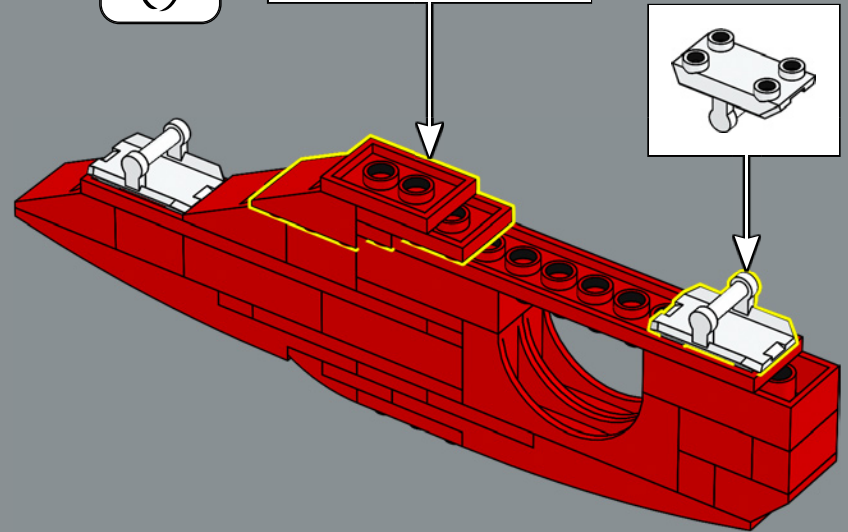
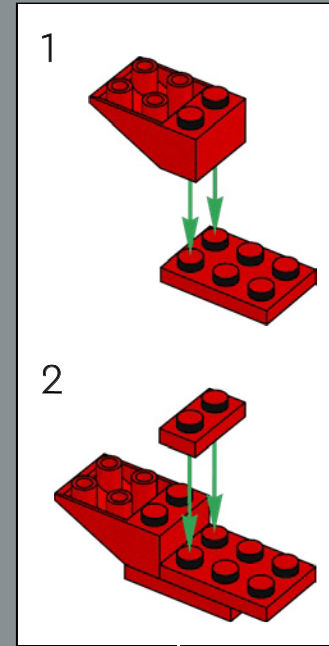

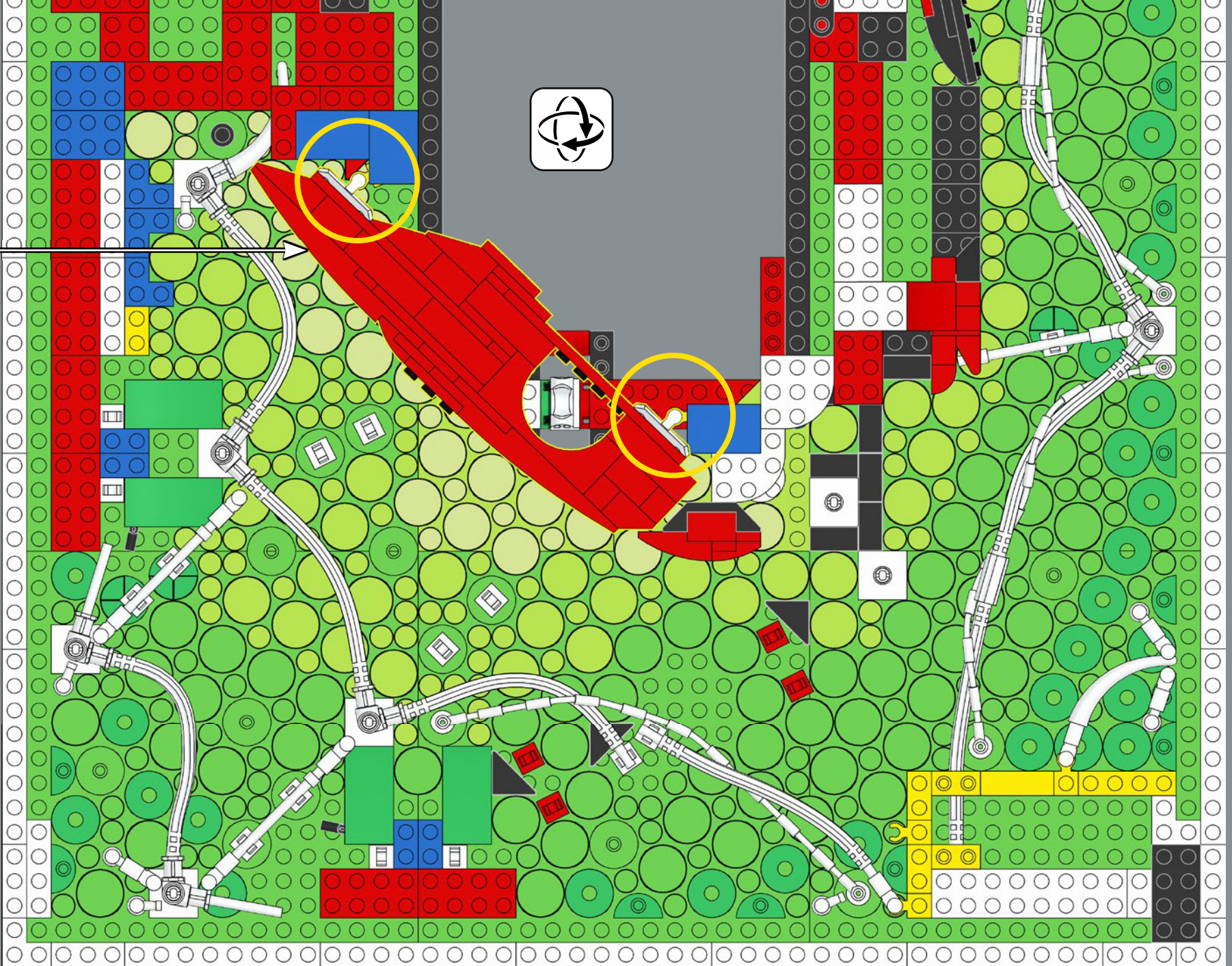



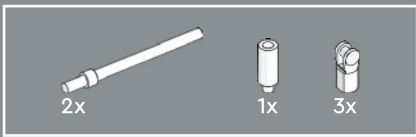

187

Originally designed as a candle, this element now serves as a web line!

Conçu à l'origine comme une bougie, cet élément sert maintenant de ligne de toile !

Diseñado originalmente como vela, ¡este elemento sirve ahora como hilo de telaraña!

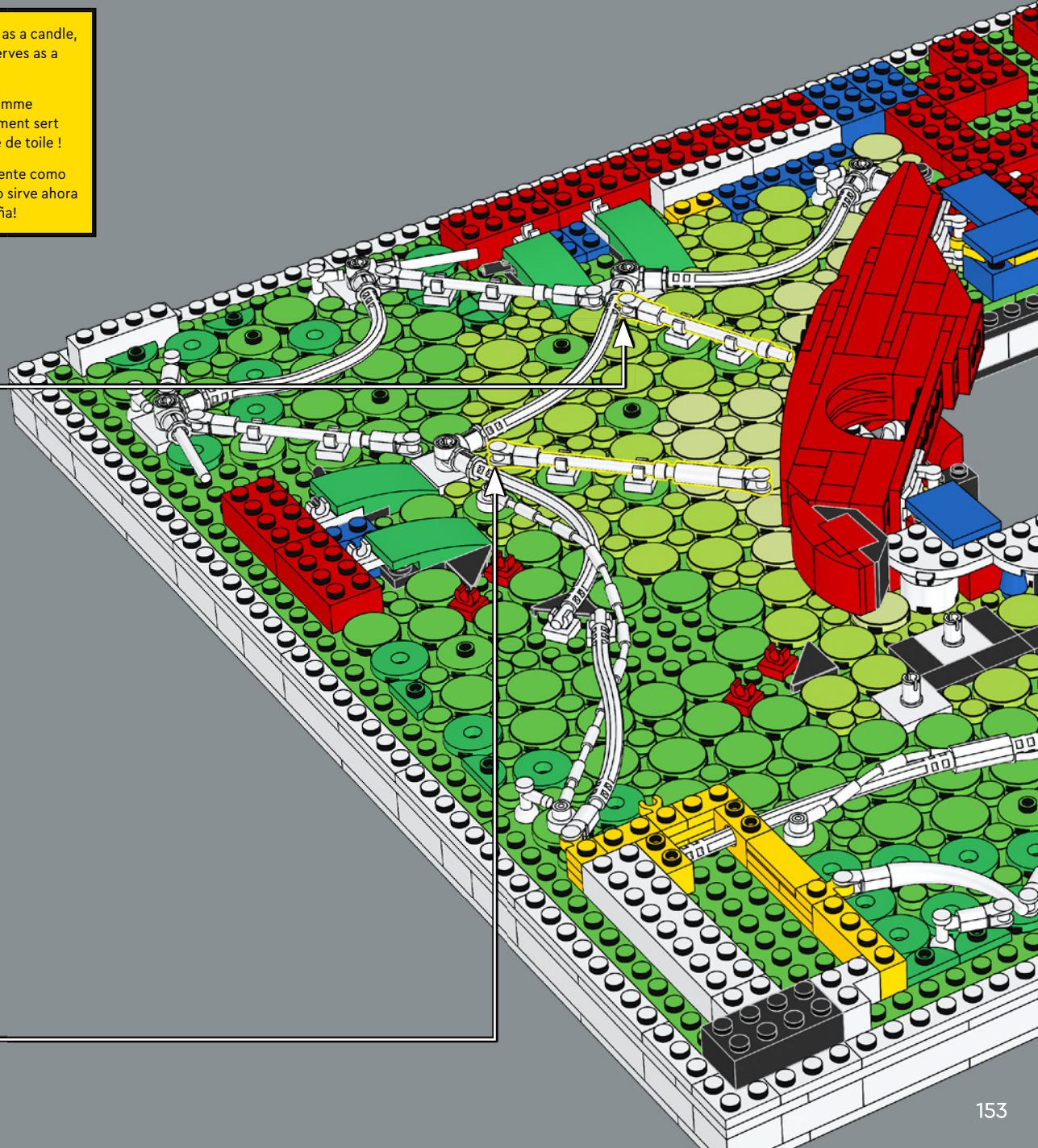
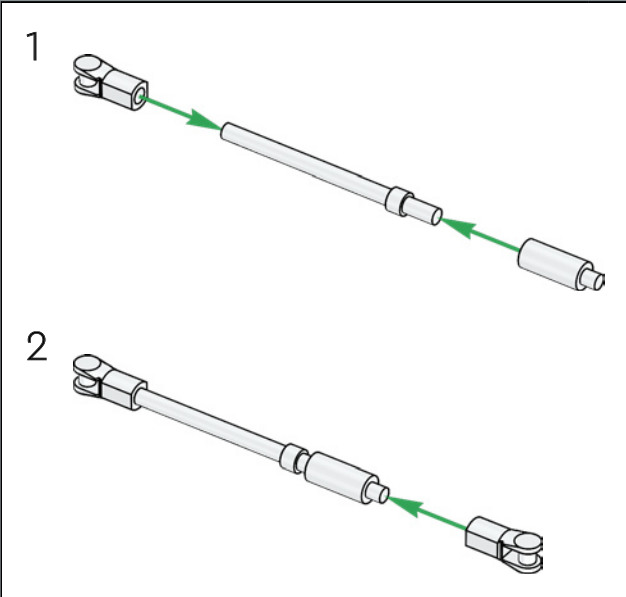
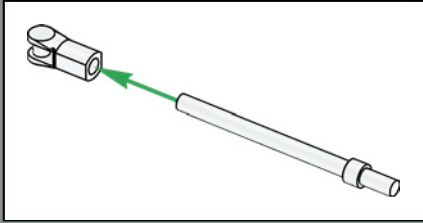

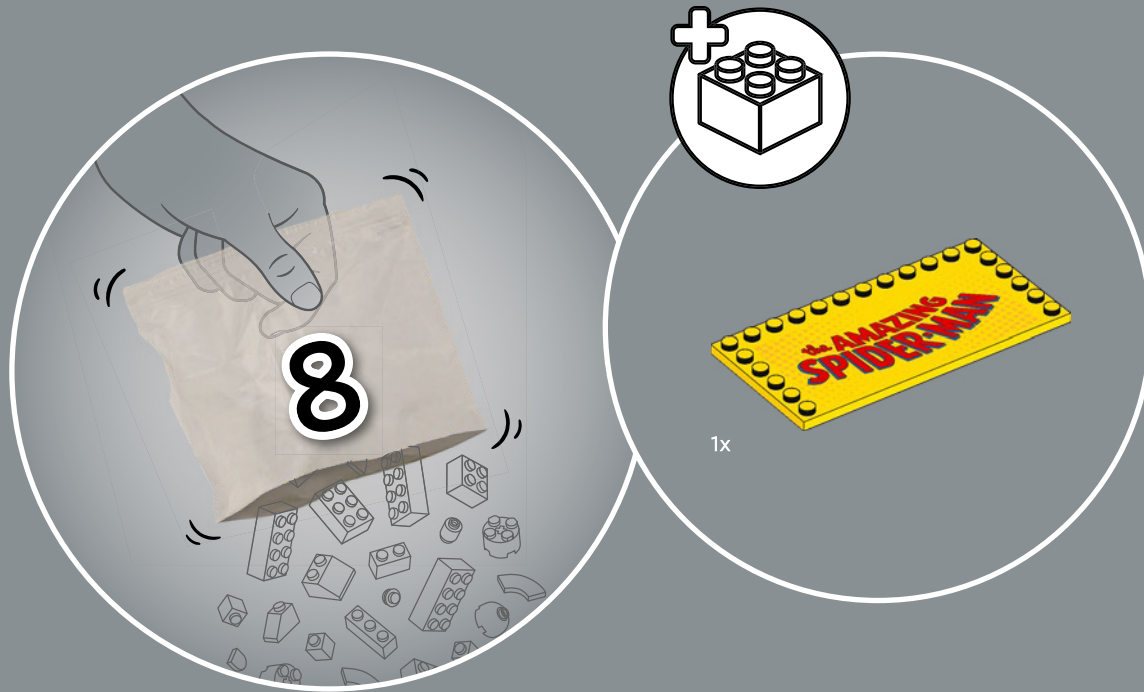

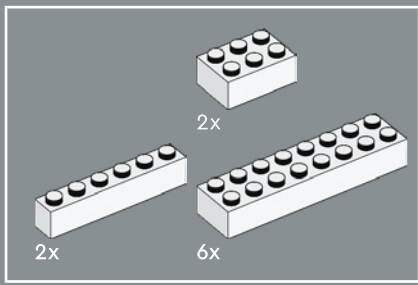

188

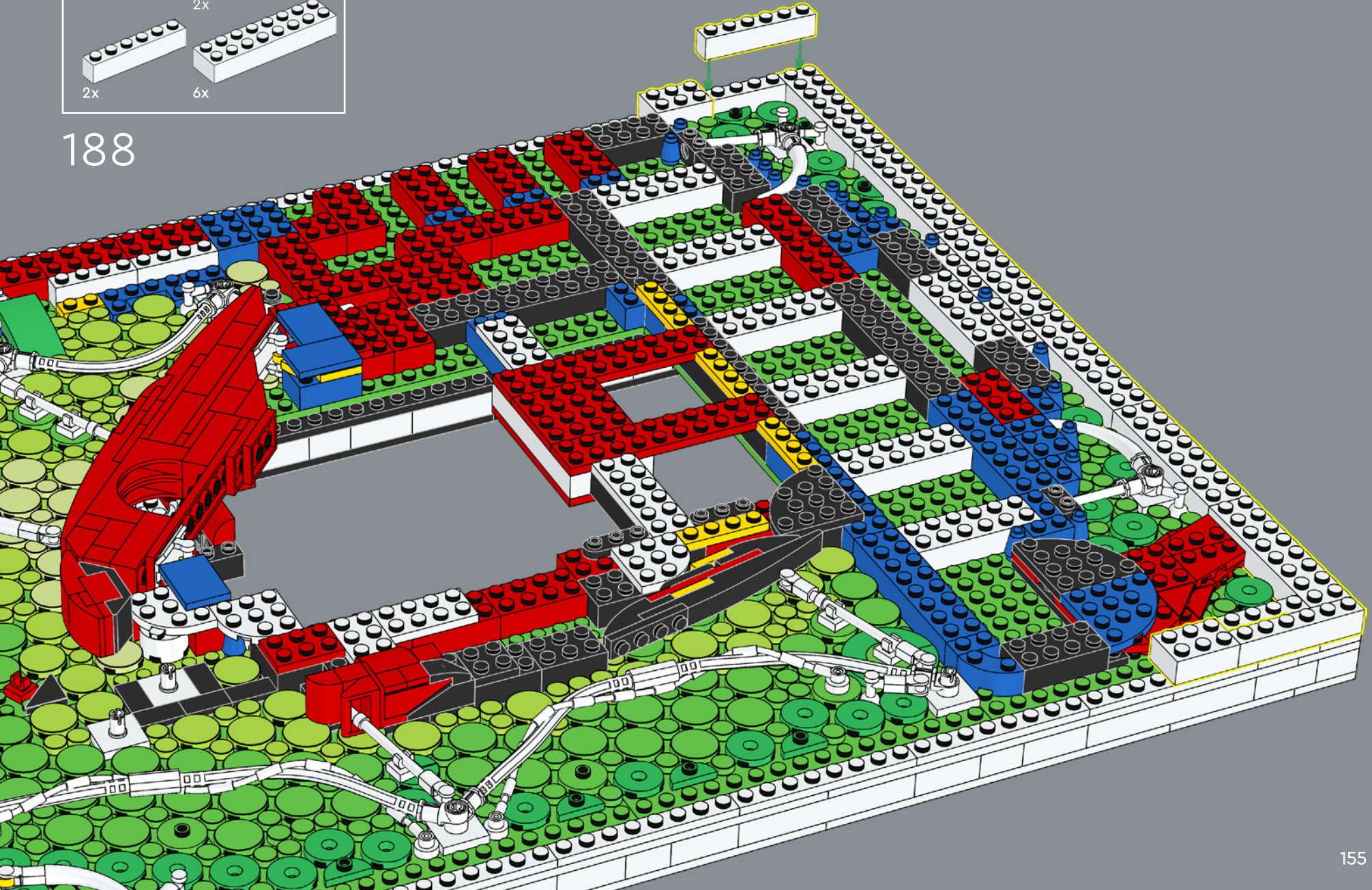

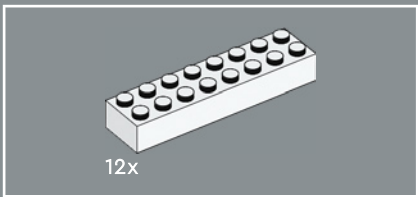

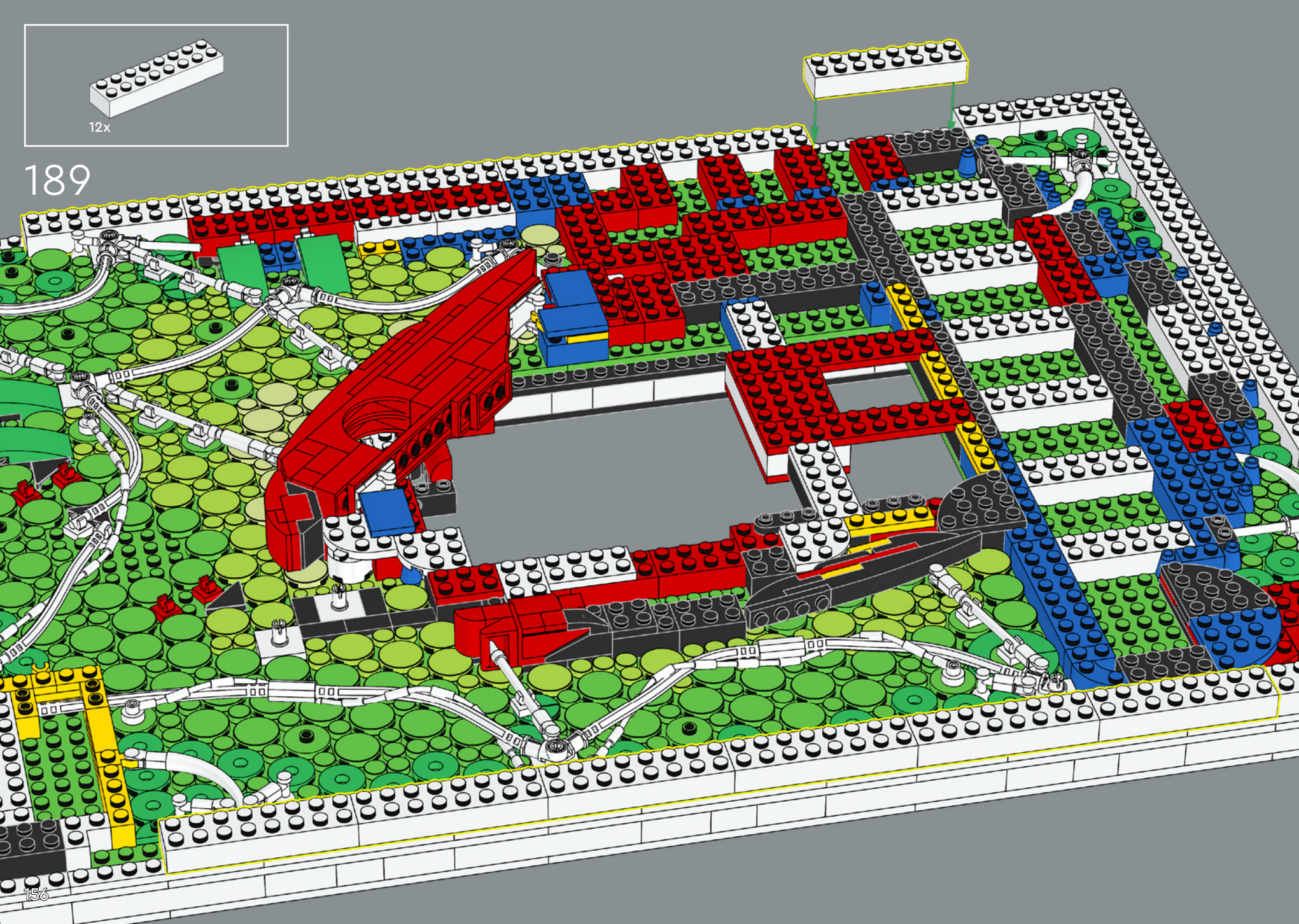

189

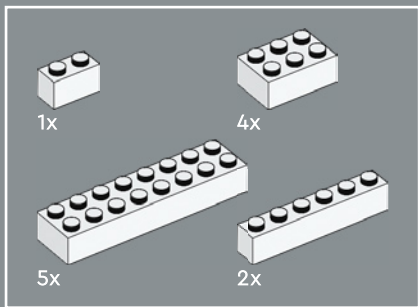

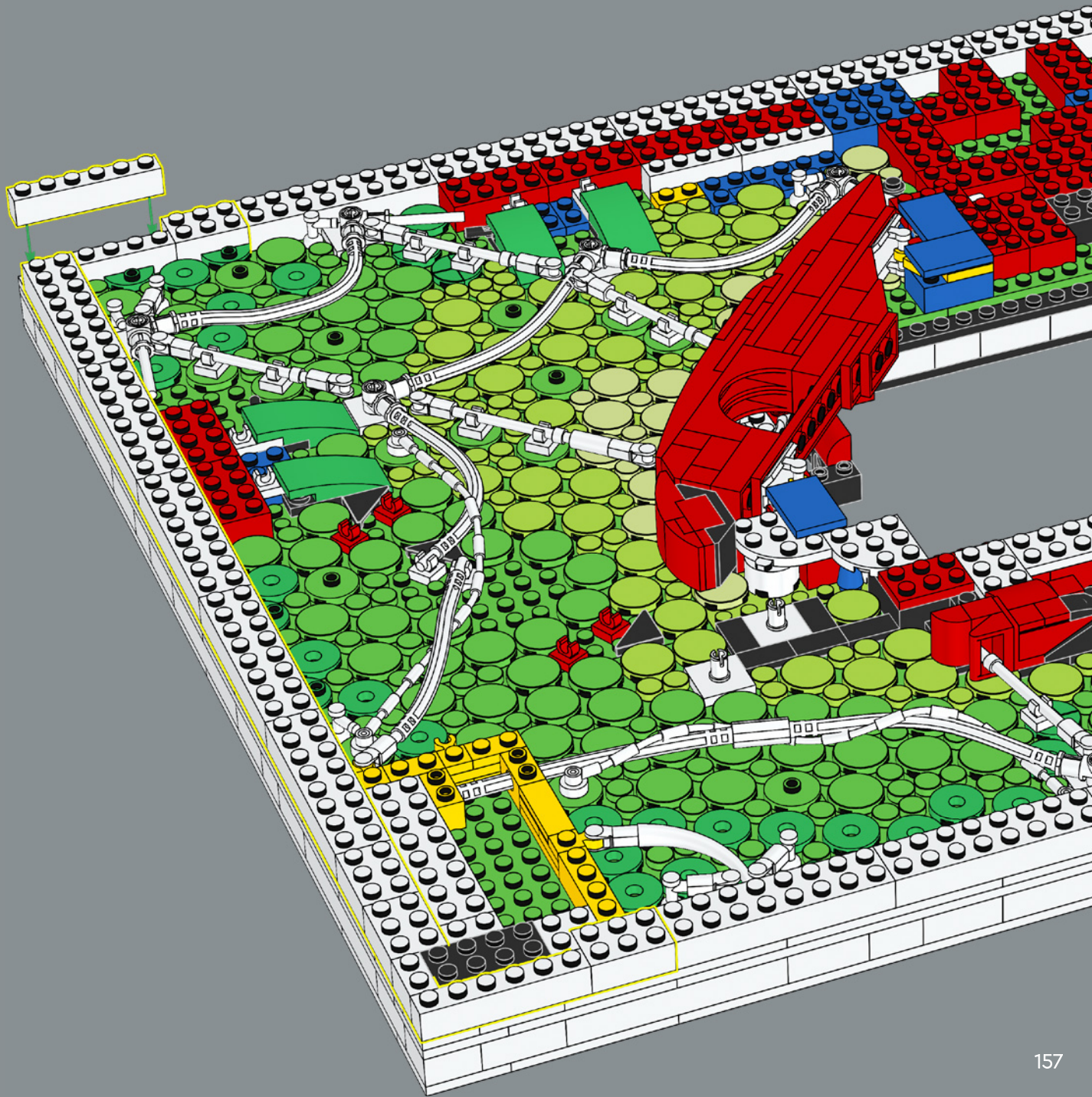

190



4x  2x 

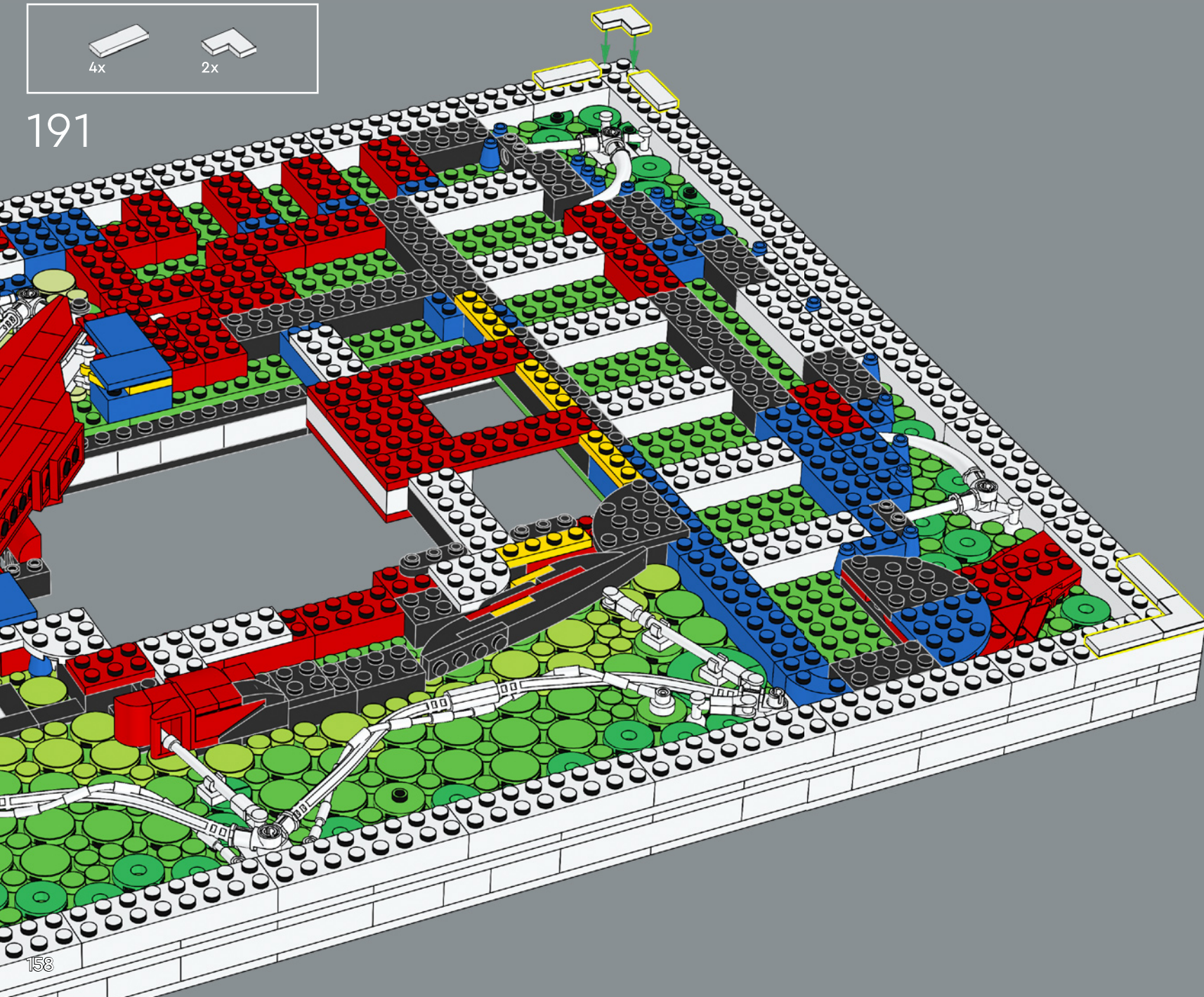

191

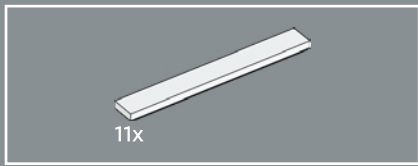

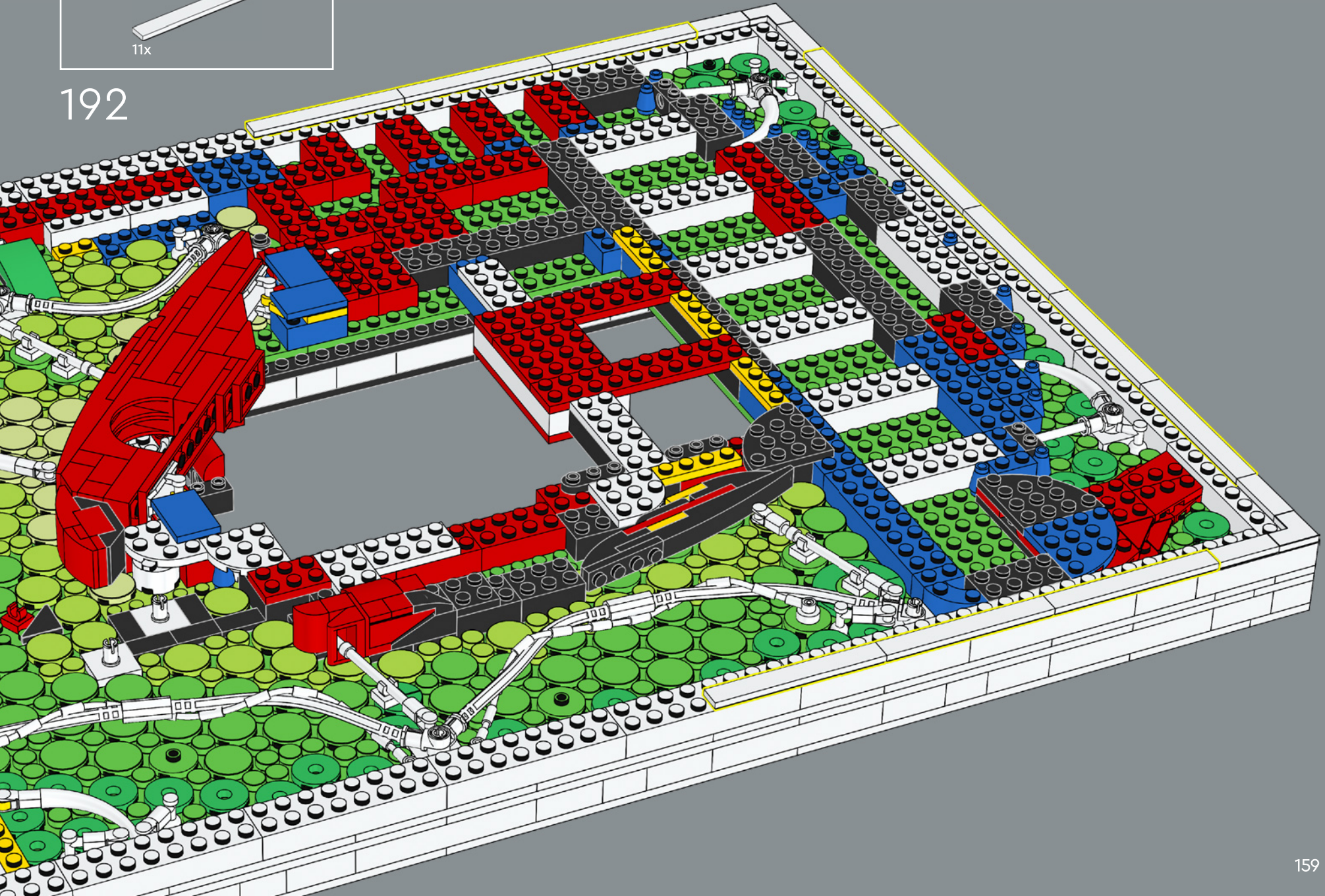

192



4x  2x 

193

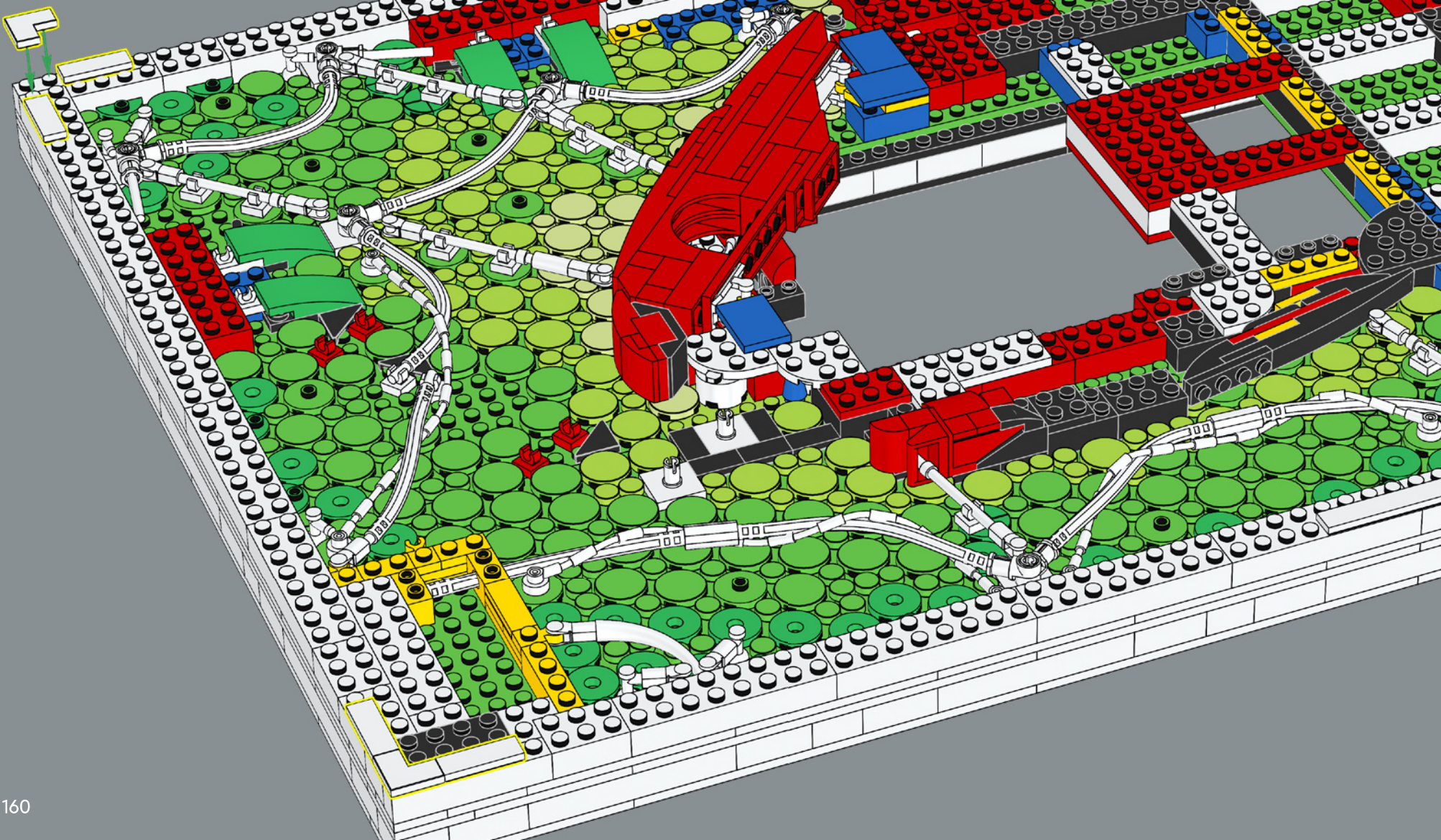



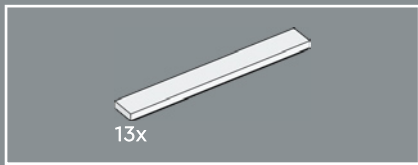

194

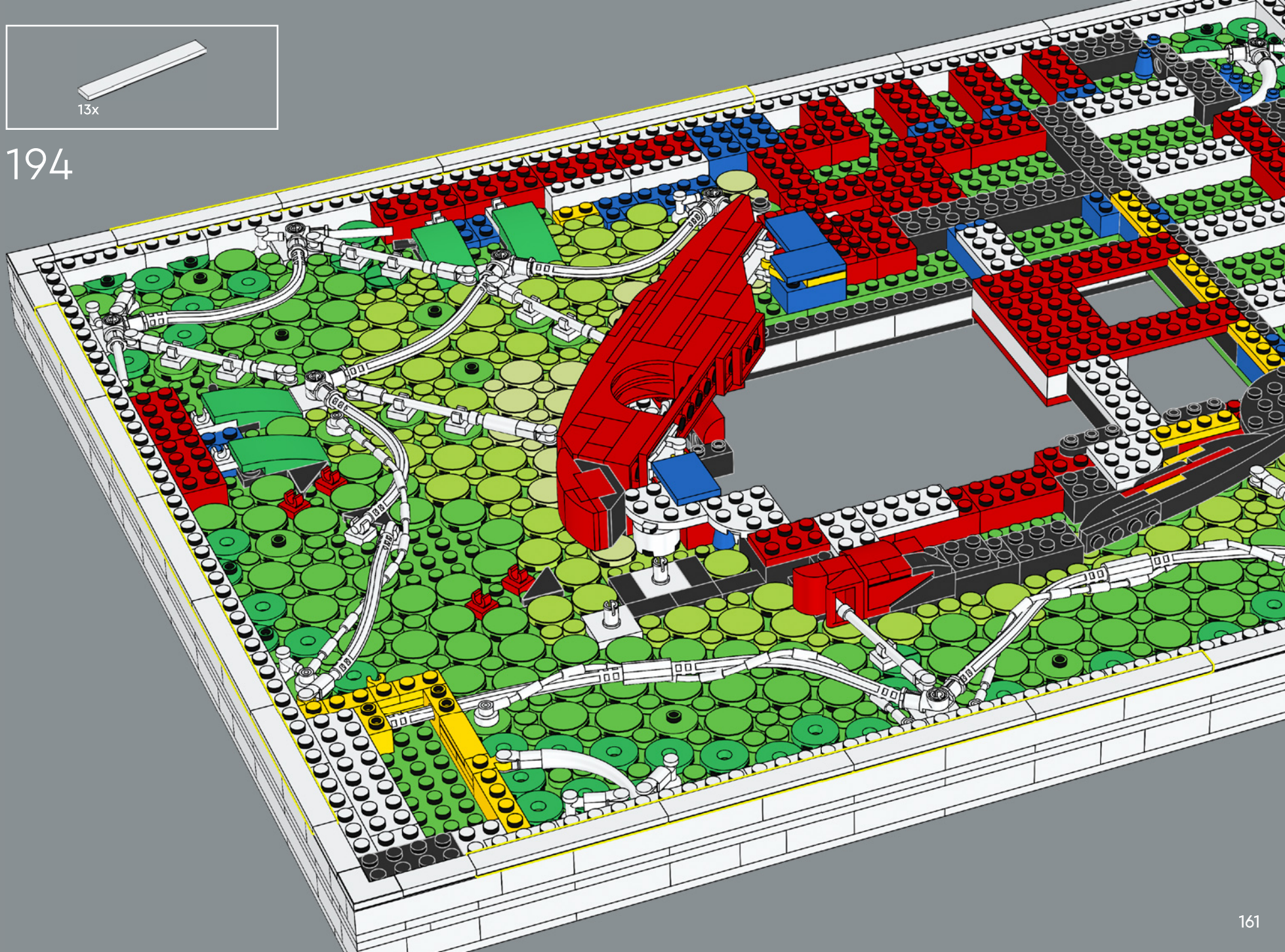

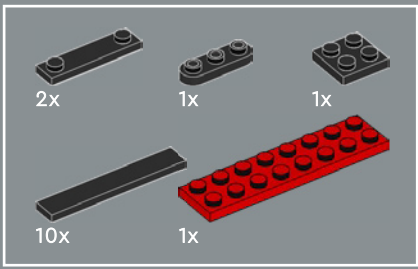

195



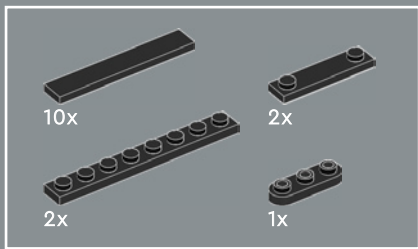

196

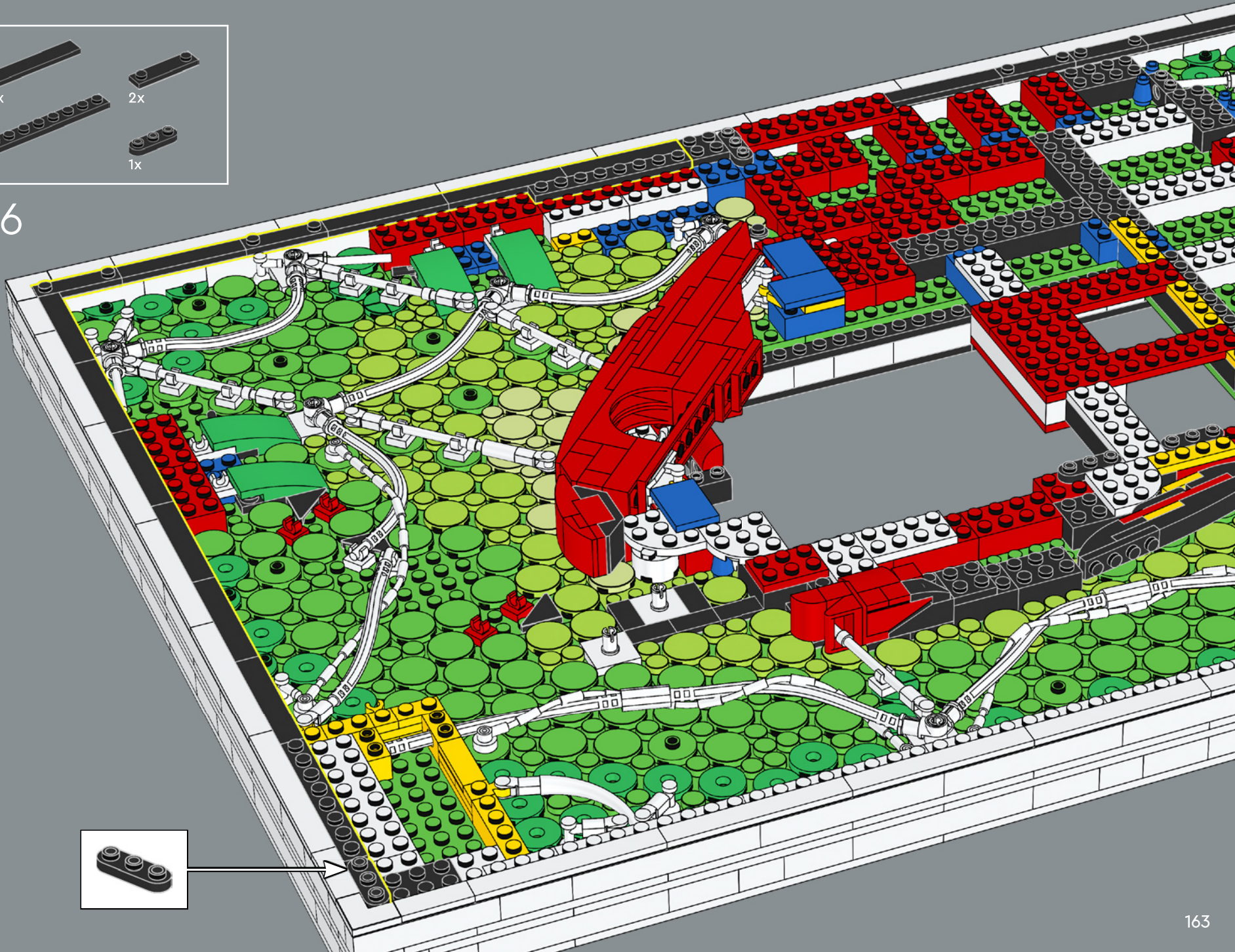

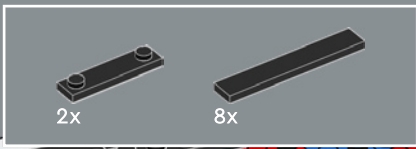

197

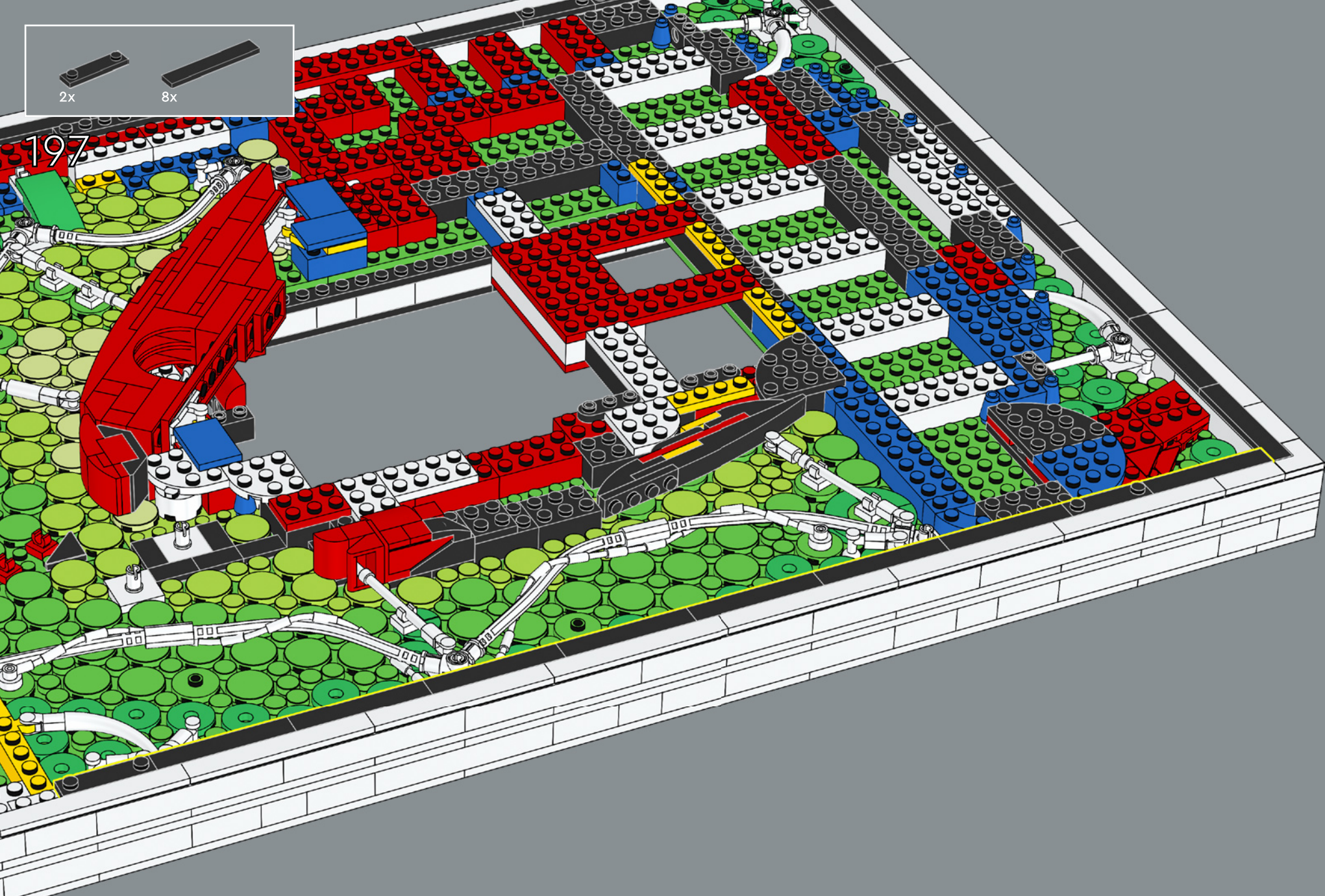

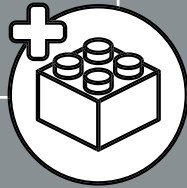
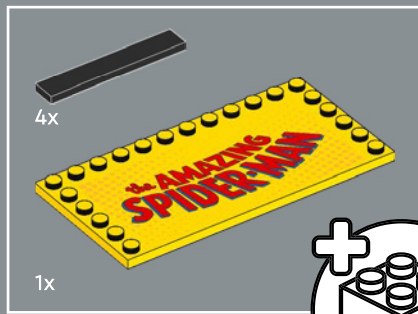

198

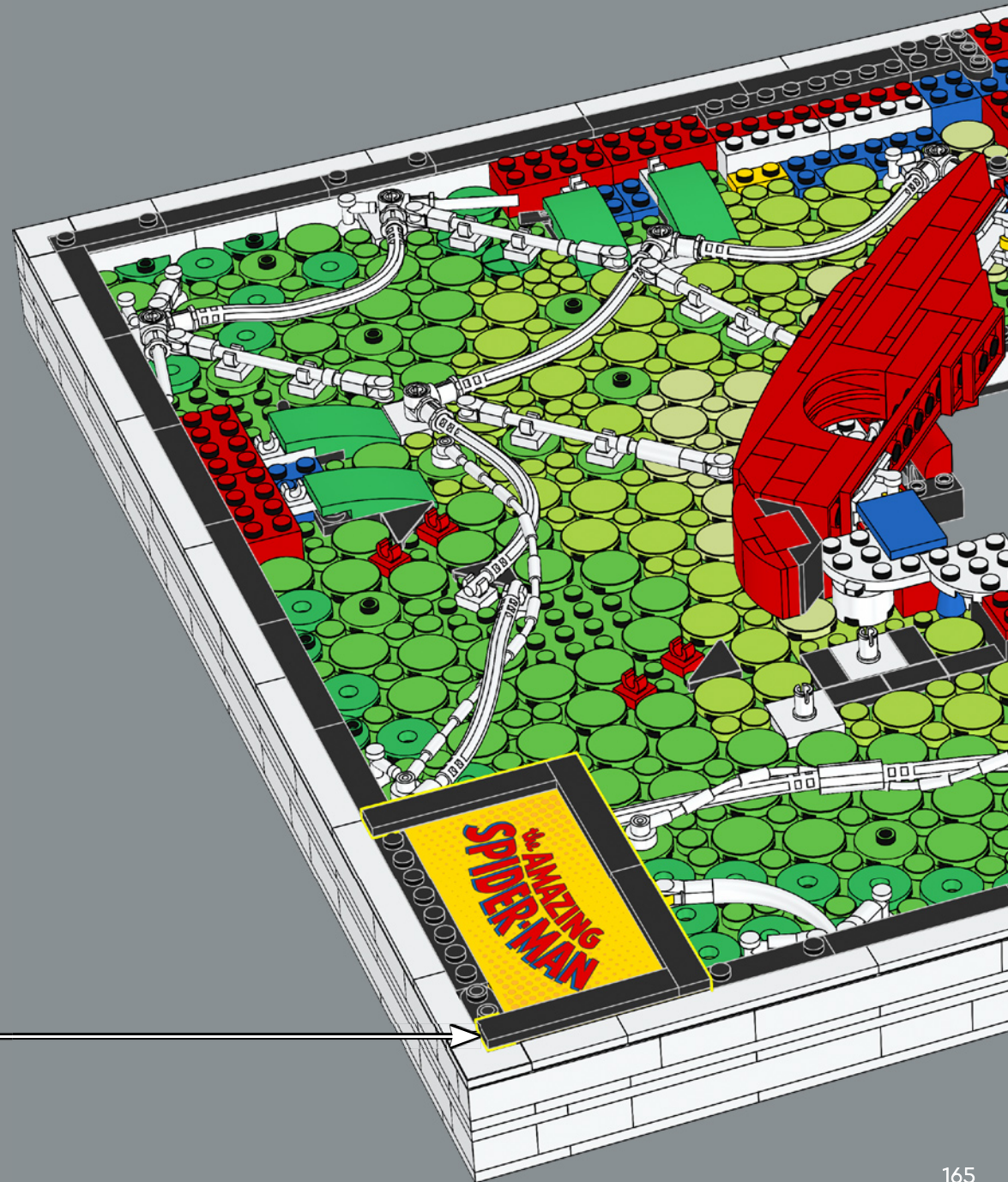
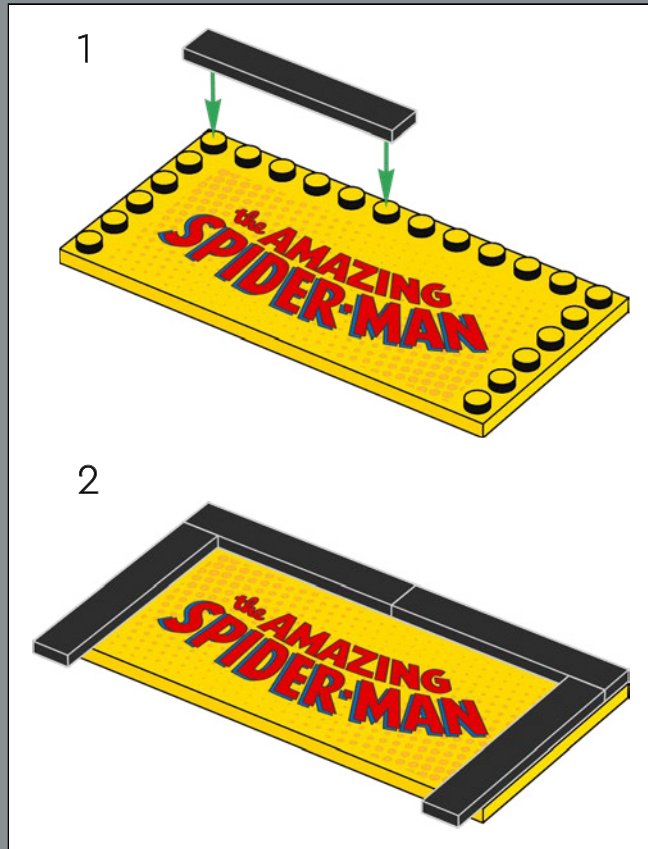

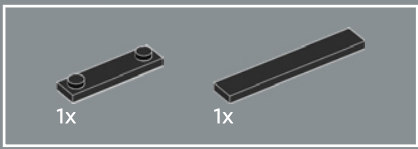

199

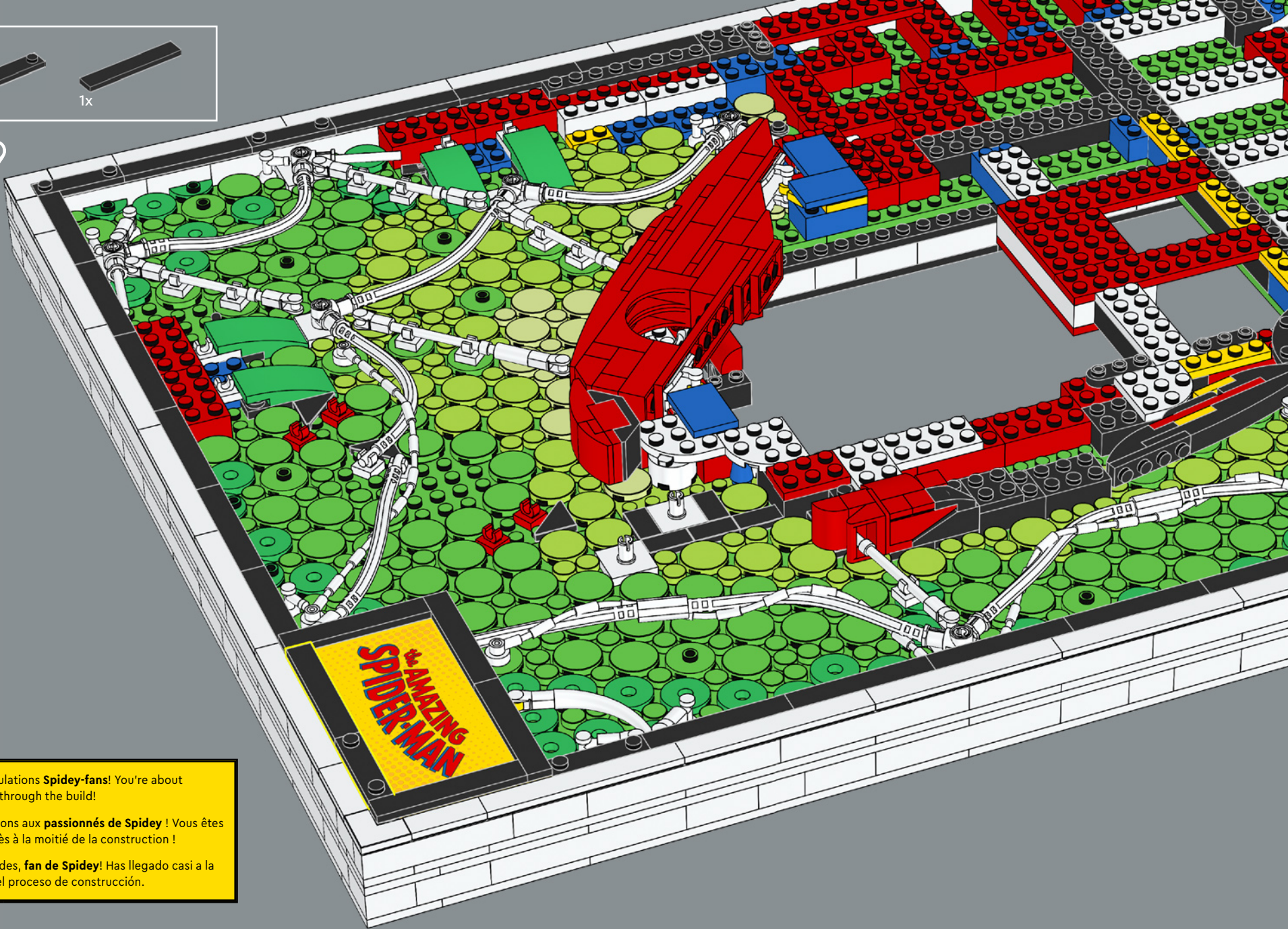

Congratulations **Spidey-fans!** You're about halfway through the build!

Félicitations aux **passionnés de Spidey !** Vous êtes à peu près à la moitié de la construction !

¡Felicidades, **fan de Spidey!** Has llegado casi a la mitad del proceso de construcción.



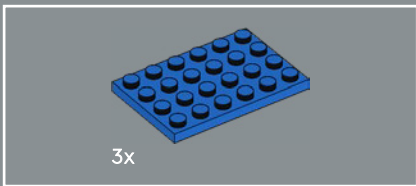

200

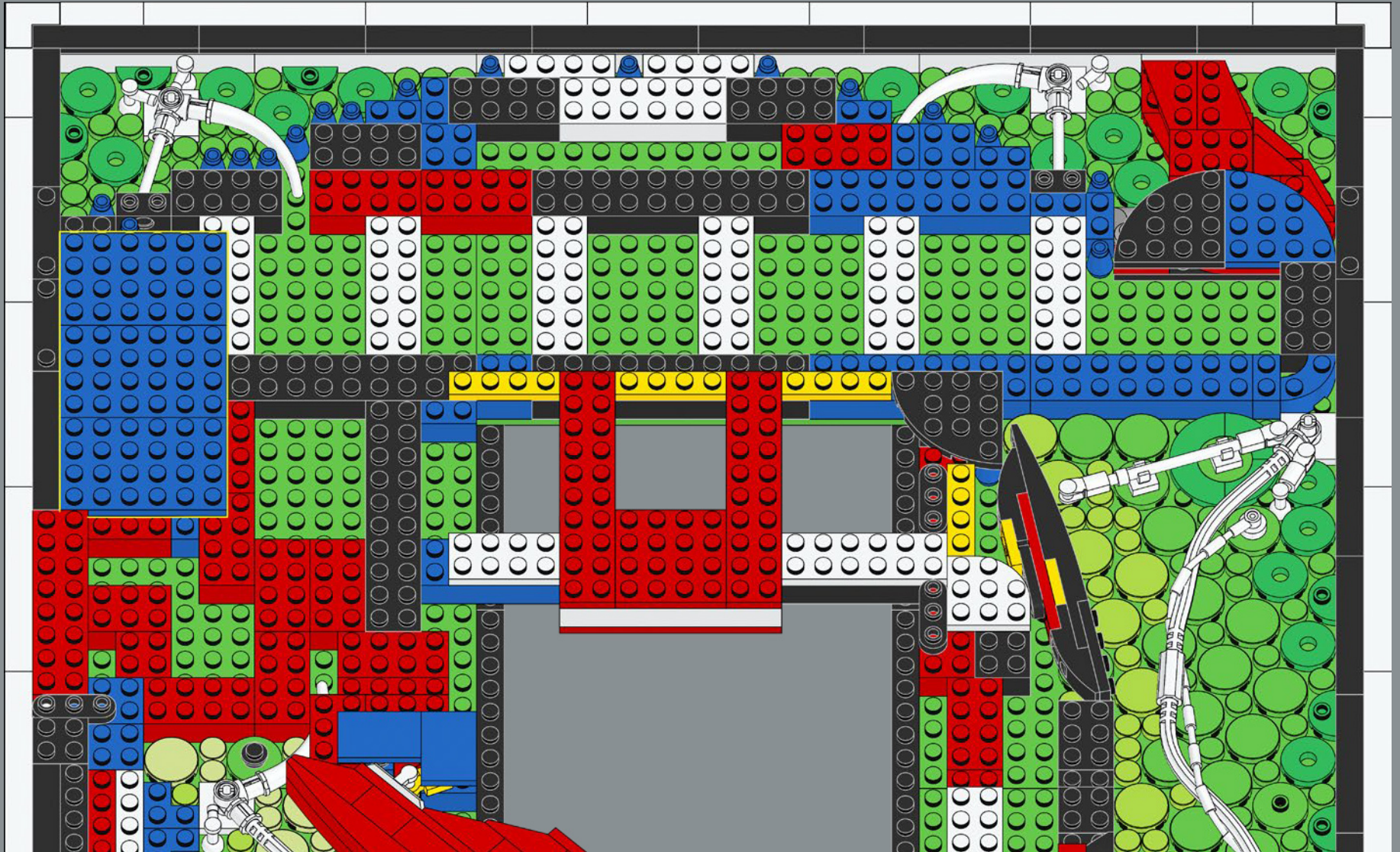





5x

201

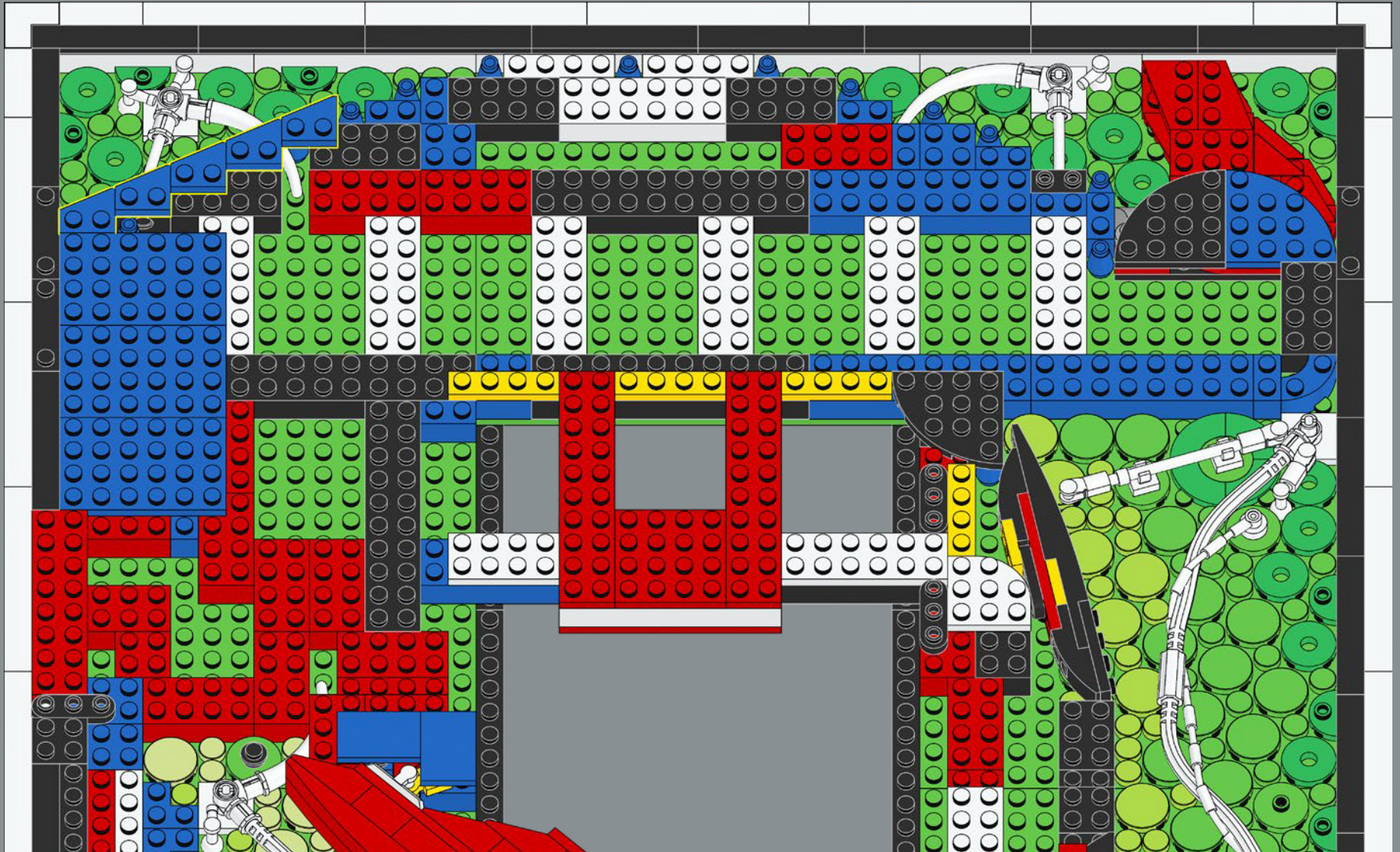

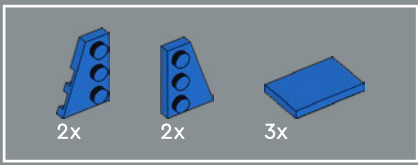

202

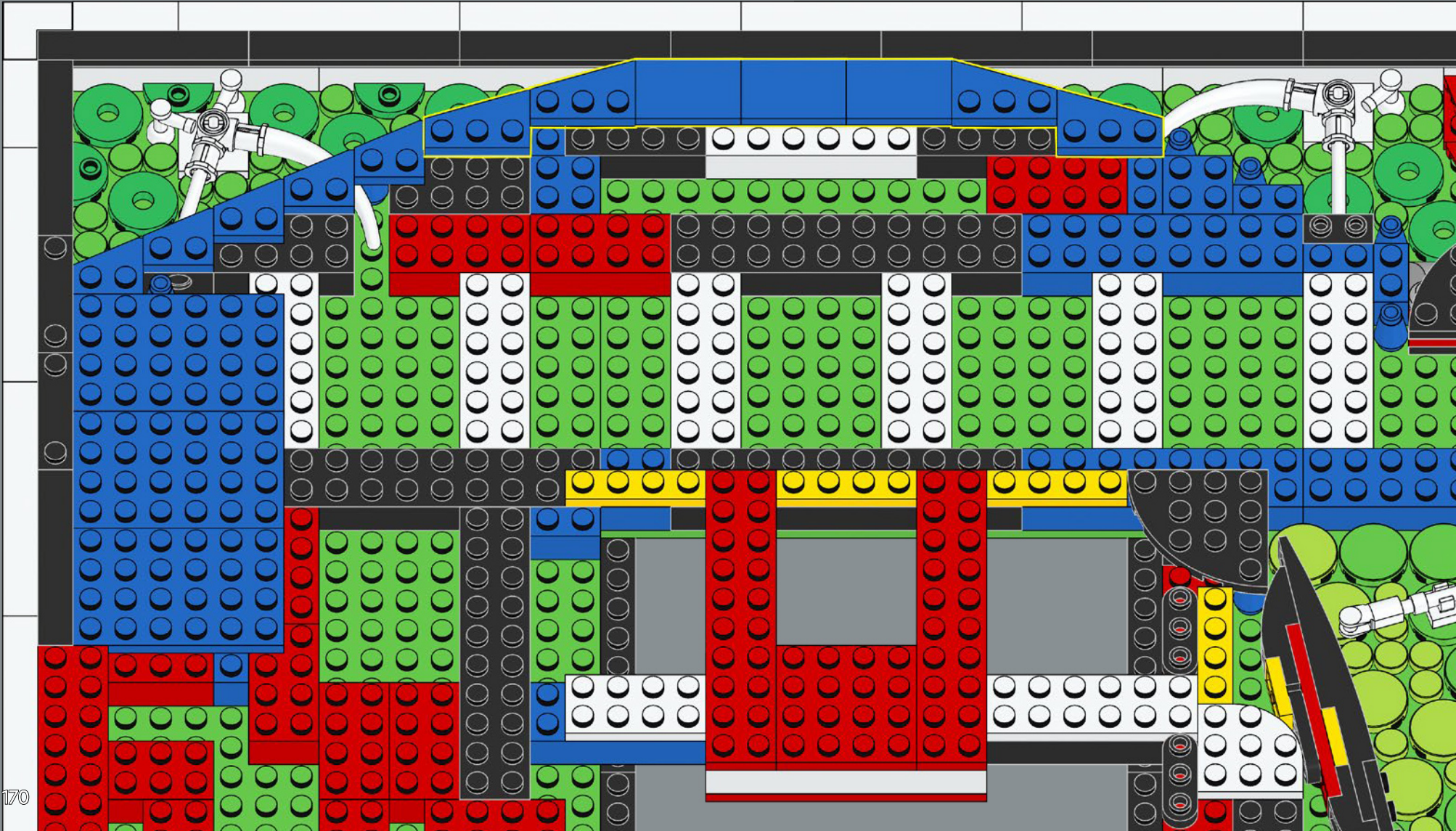

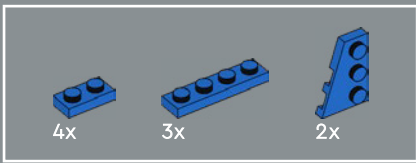

203

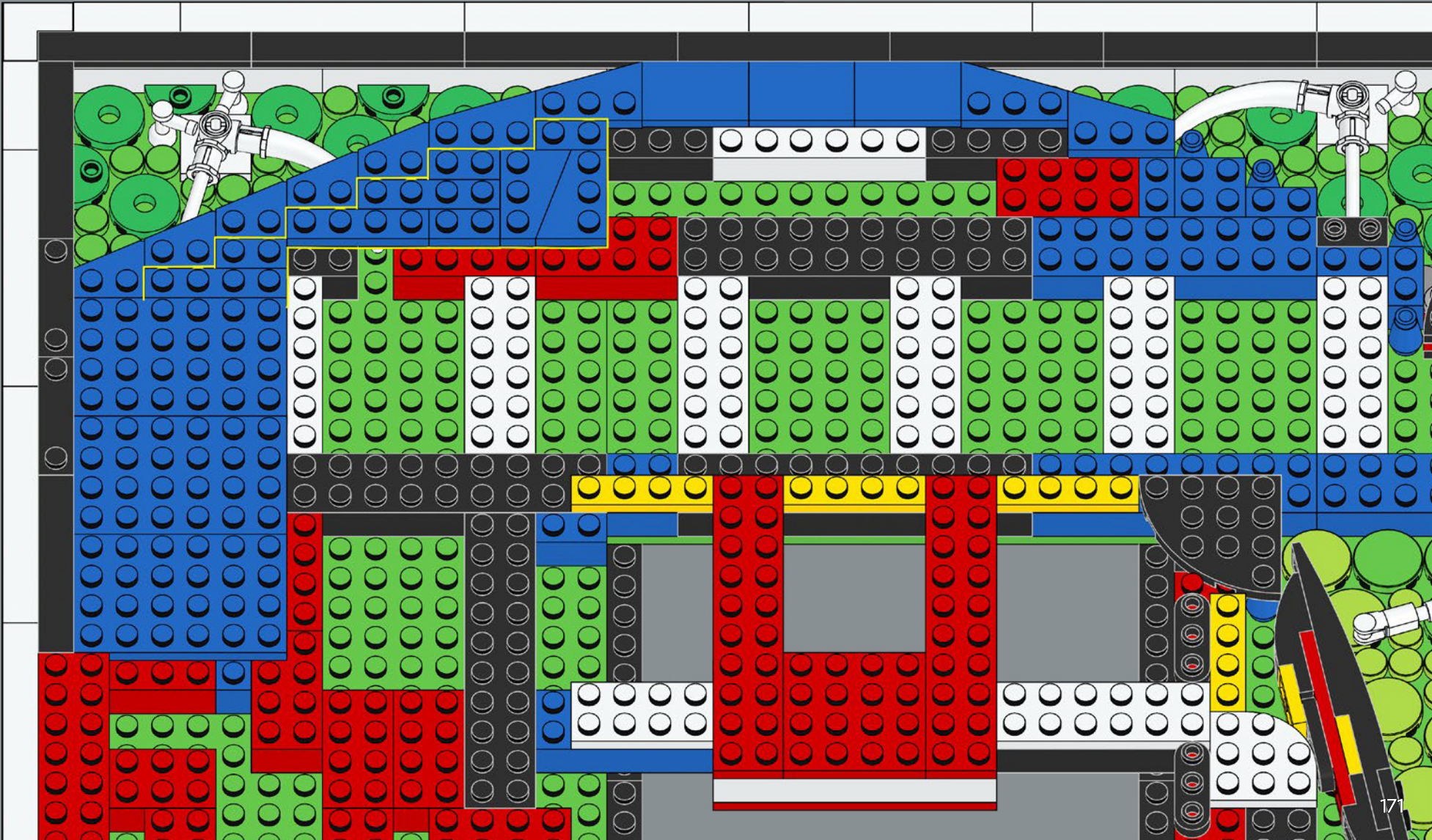

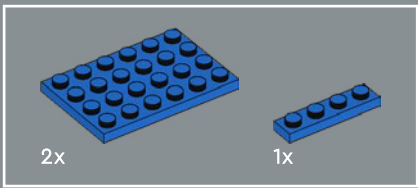

204

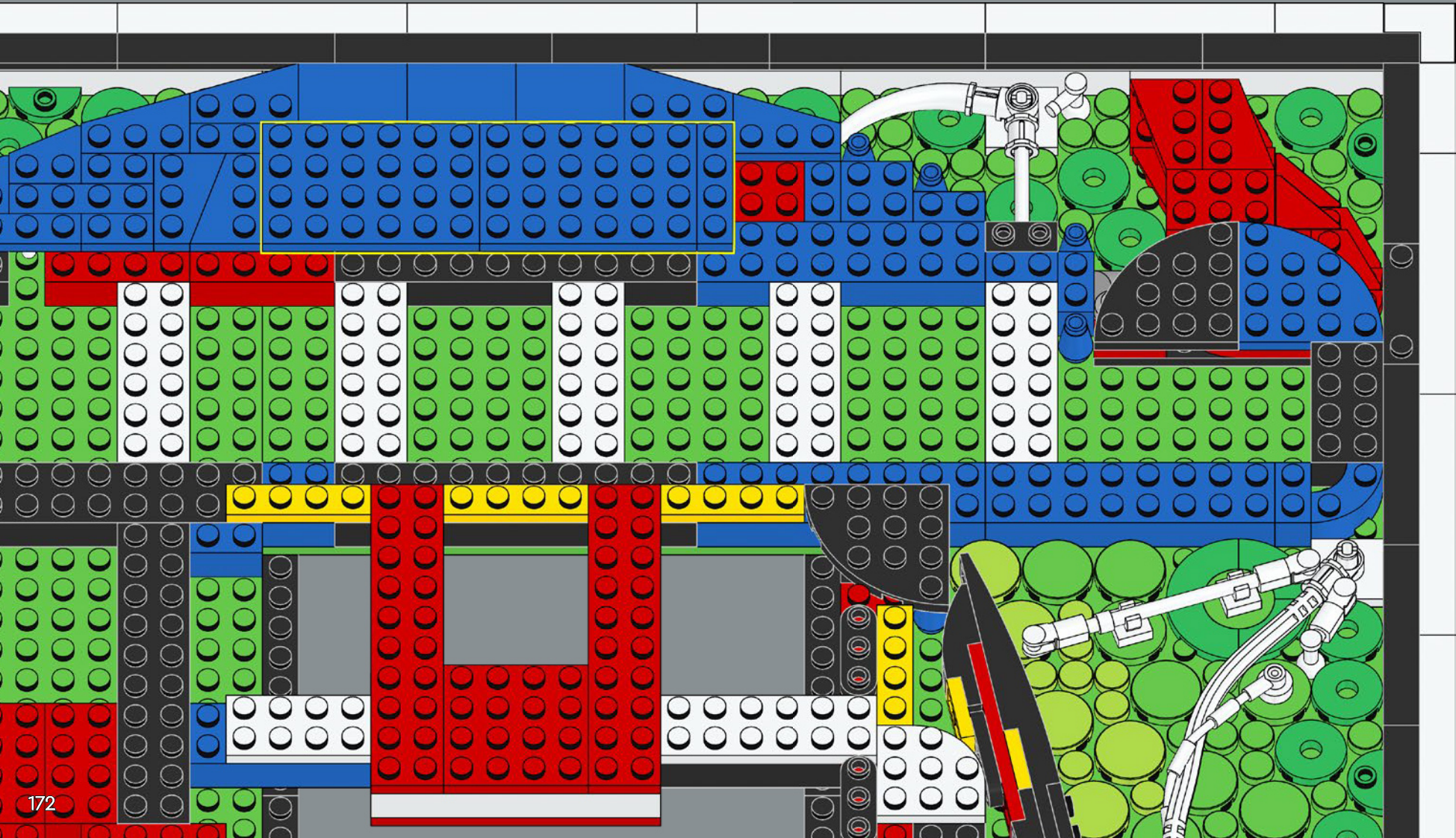

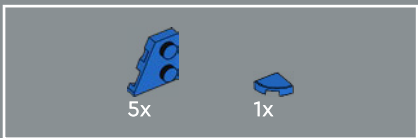

205

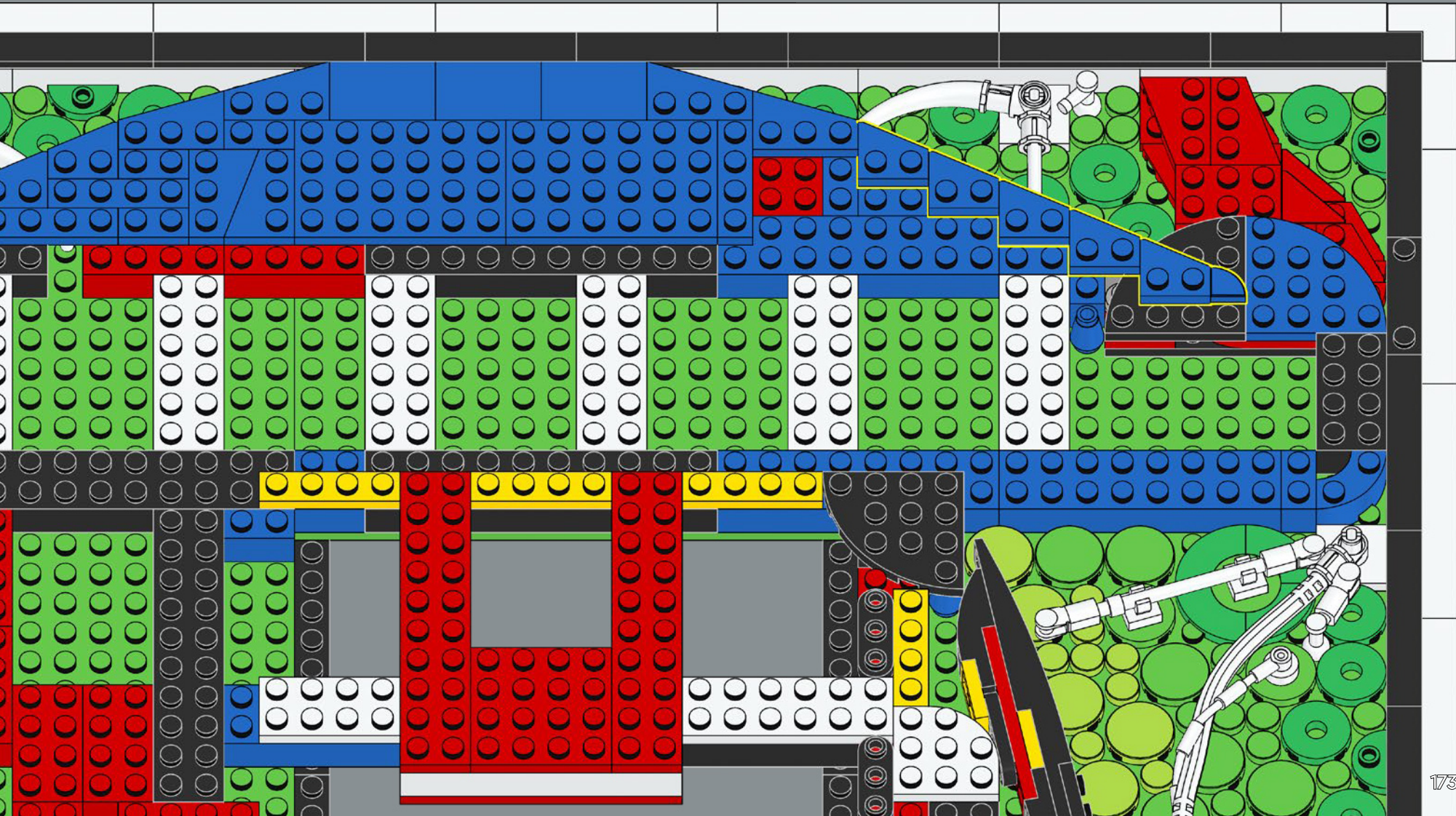

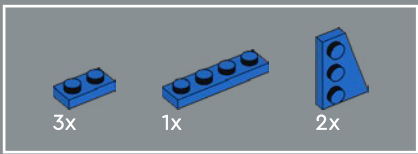

206

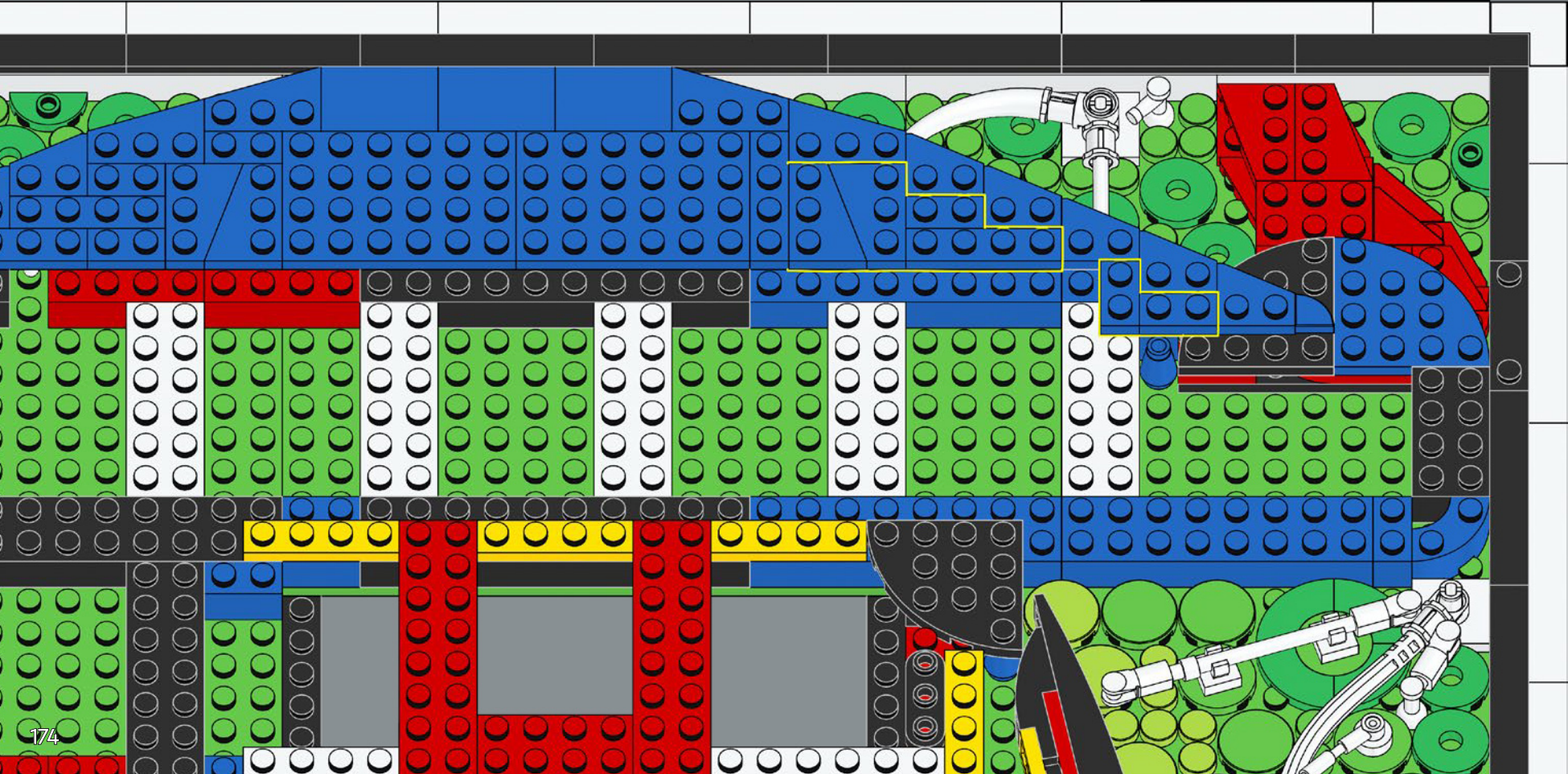

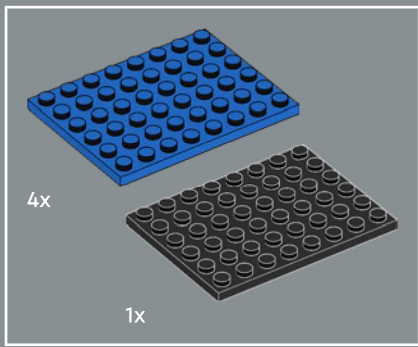

207

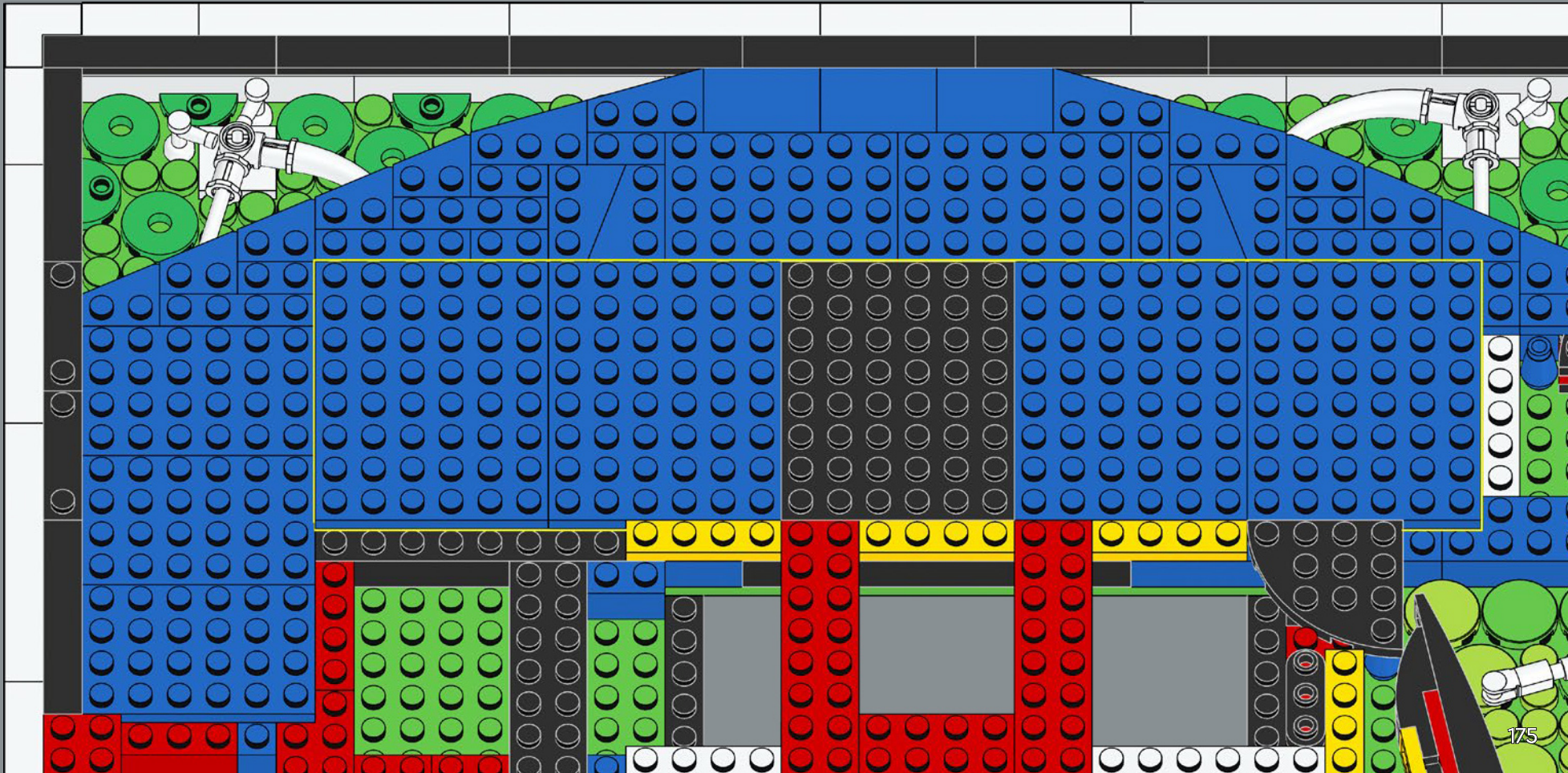

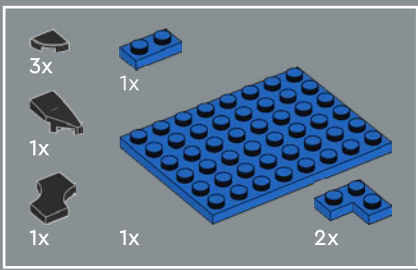

208

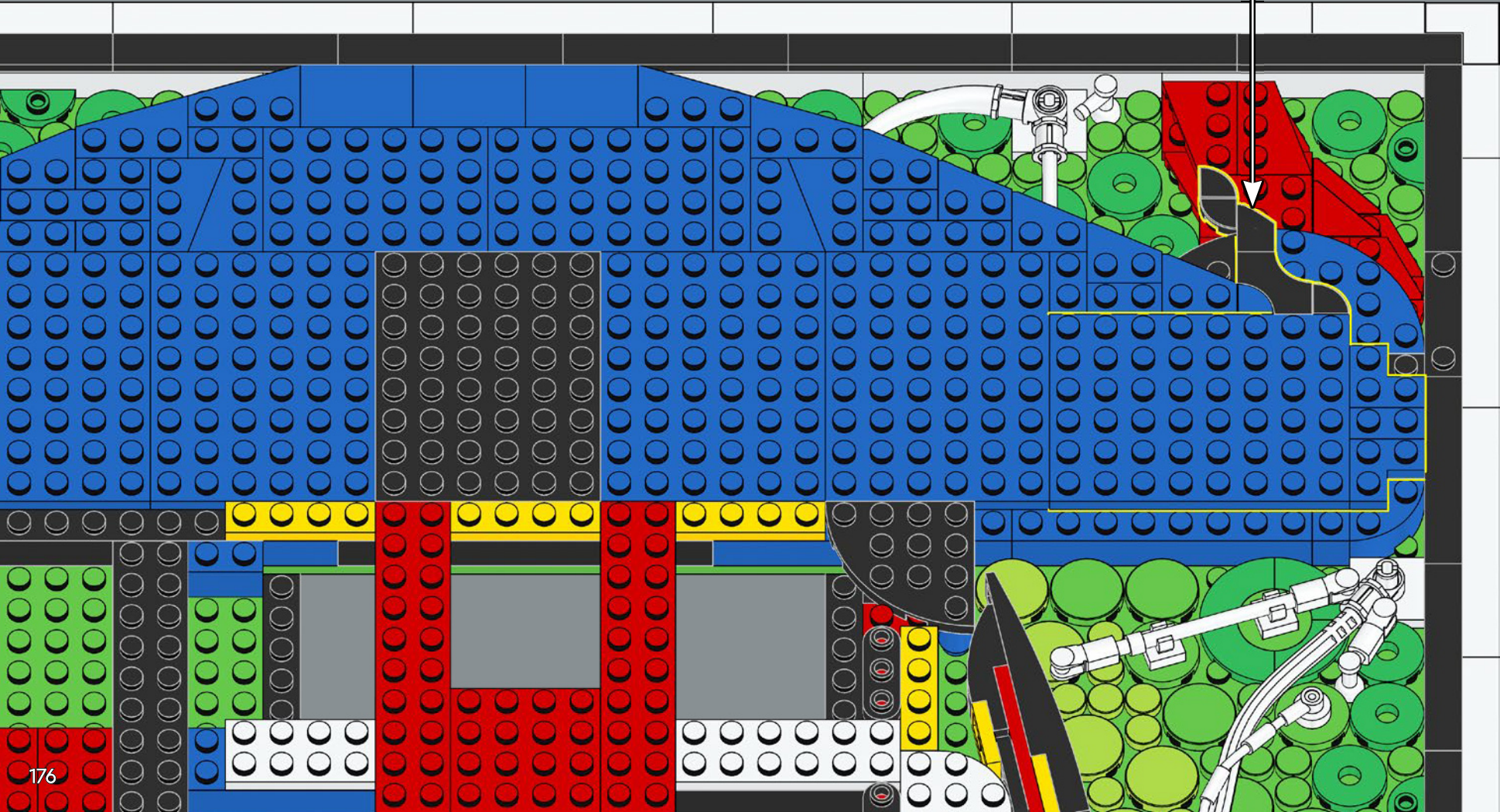



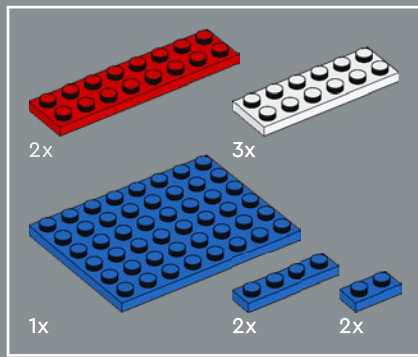

209

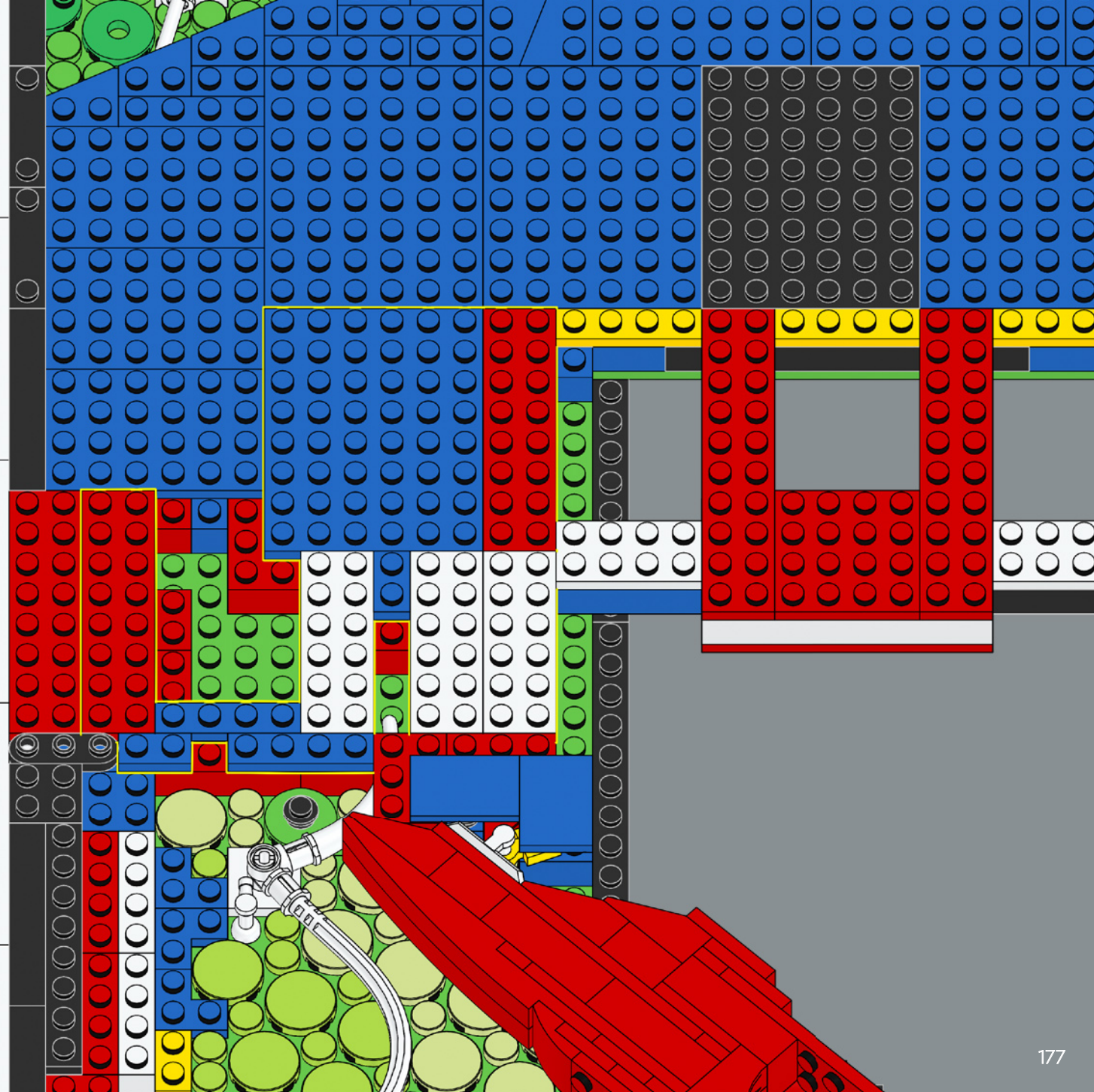

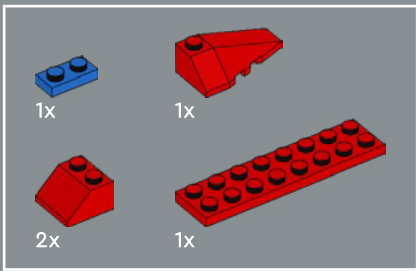

Did you know? Spider-Man was originally intended to have an **orange and purple costume**, but it was switched to the iconic **red and blue** because it would print cleaner on pulp paper.

Le saviez-vous ? À l'origine, Spider-Man devait avoir un **costume orange et violet**, mais il a été remplacé par l'emblématique **rouge et bleu** parce qu'il s'imprimait plus proprement sur du papier de pâte.

¿Lo sabías? Originalmente, Spider-Man iba a llevar un **traje en naranja y morado**, pero se cambió al icónico **rojo y azul** porque quedaría más limpio en las impresiones comerciales.

210

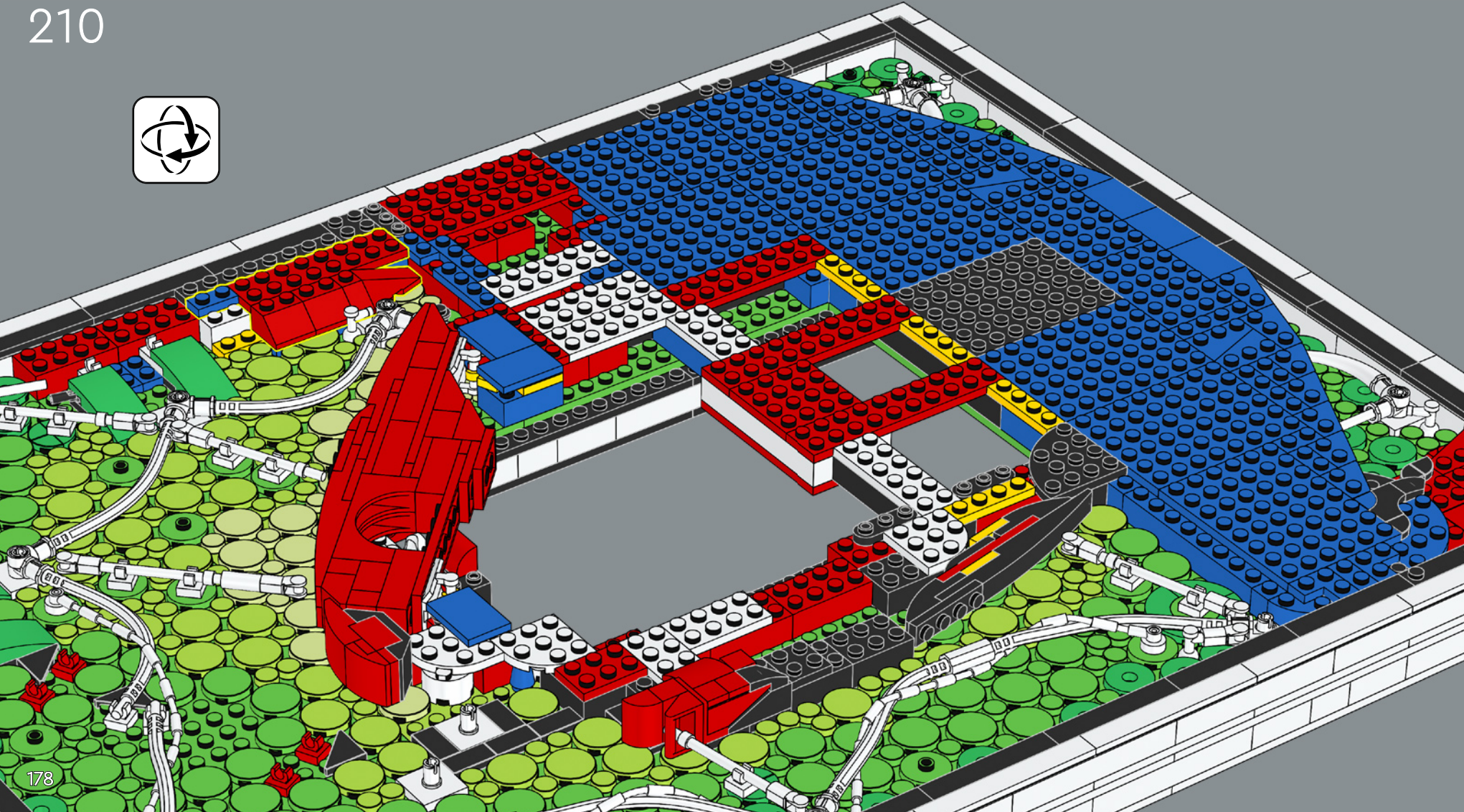

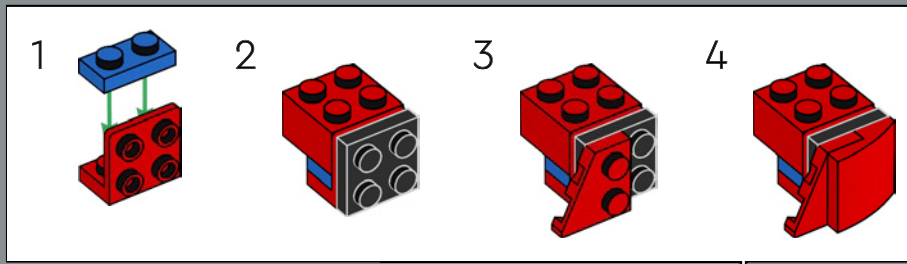
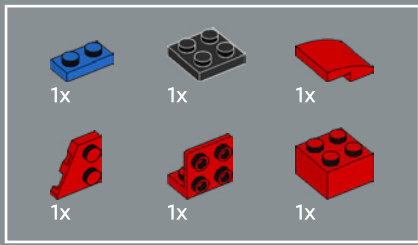

211

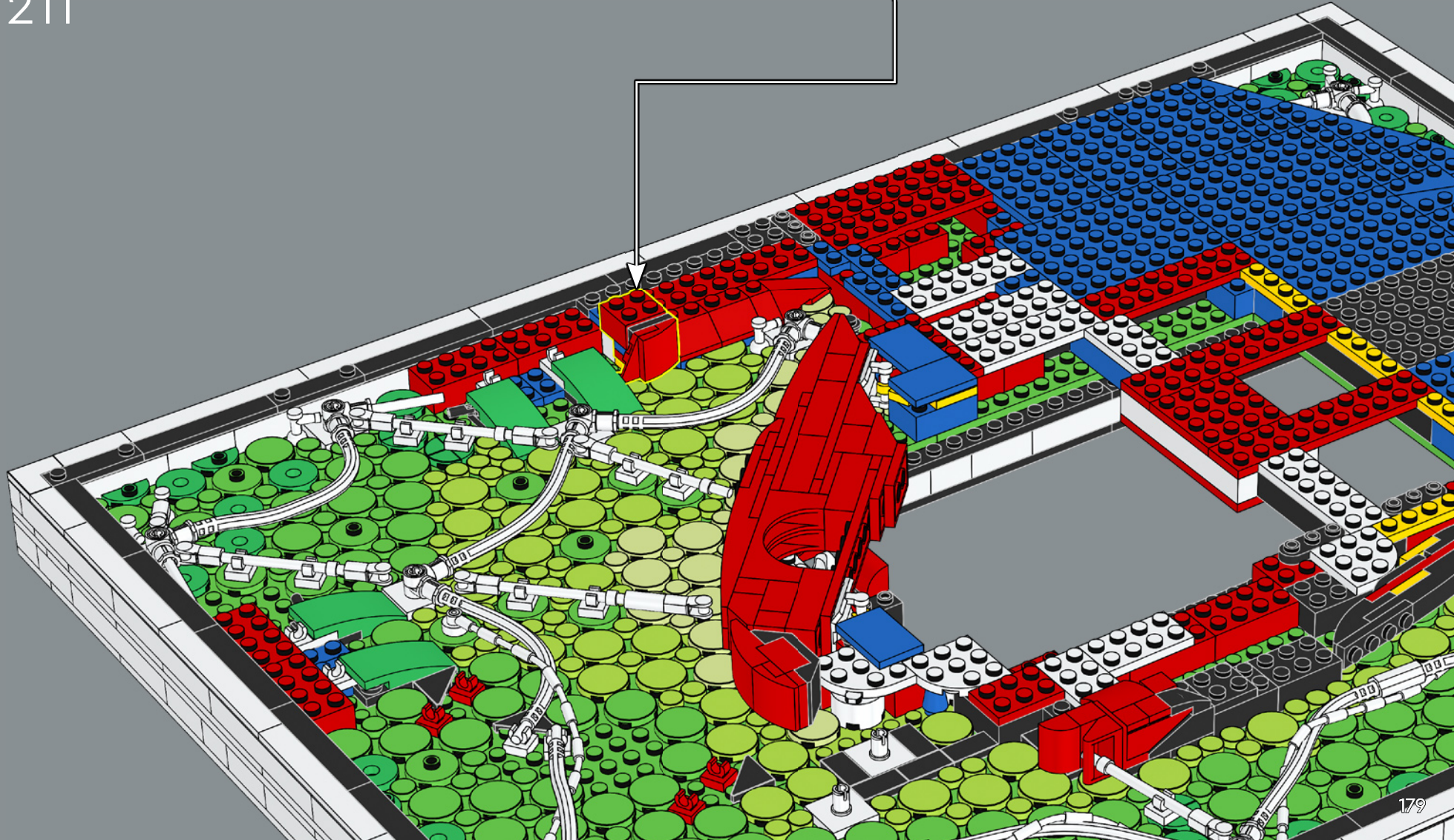

1x  1x 

212

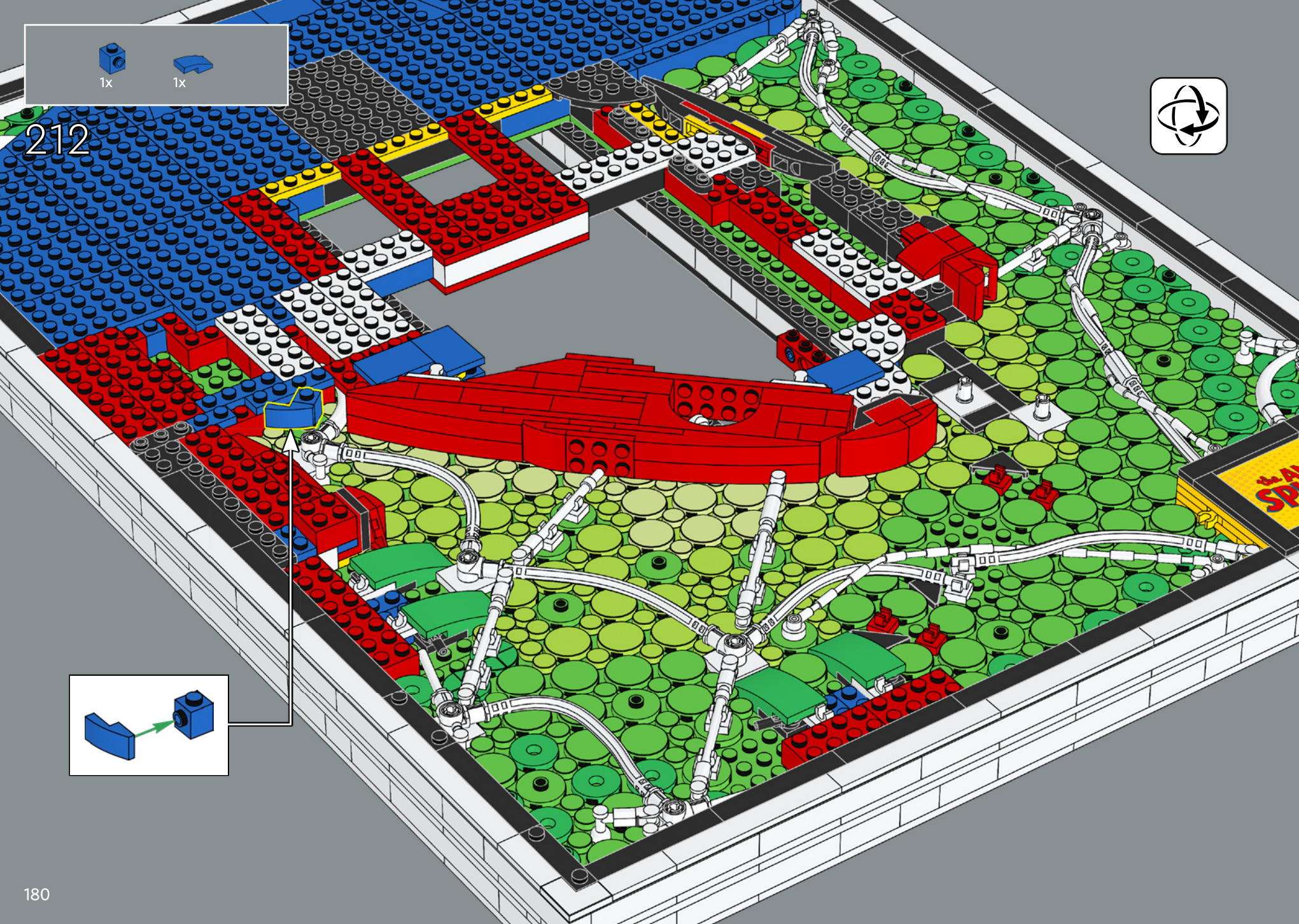
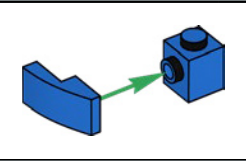

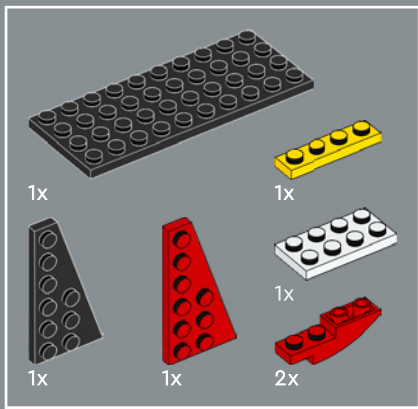

213

1

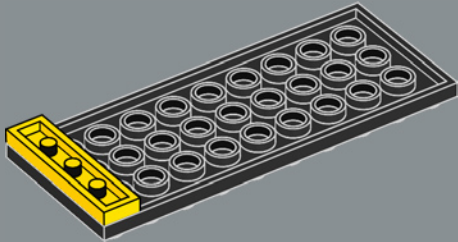

2

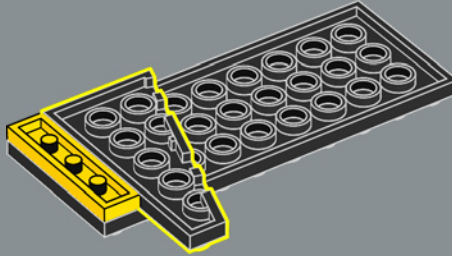

3

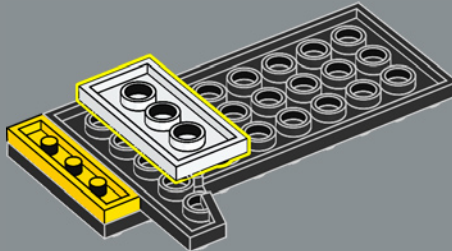

4

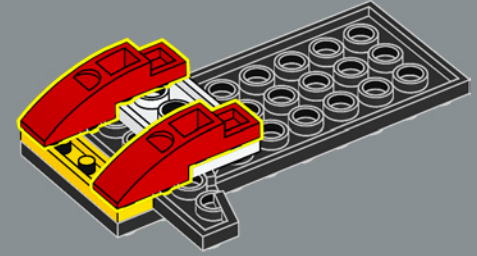

5

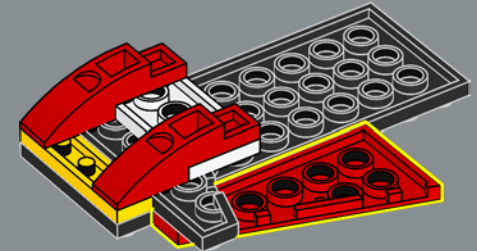

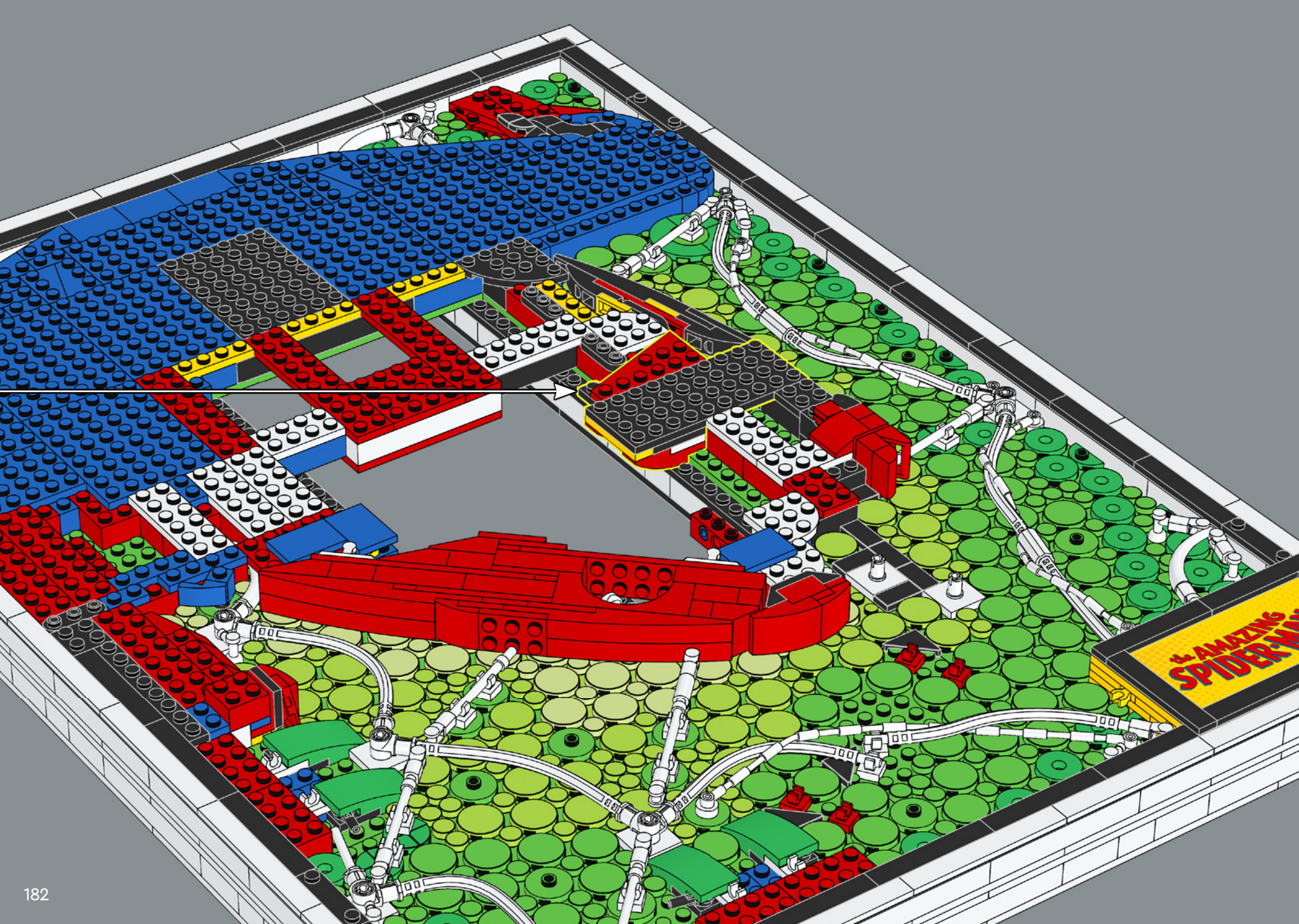

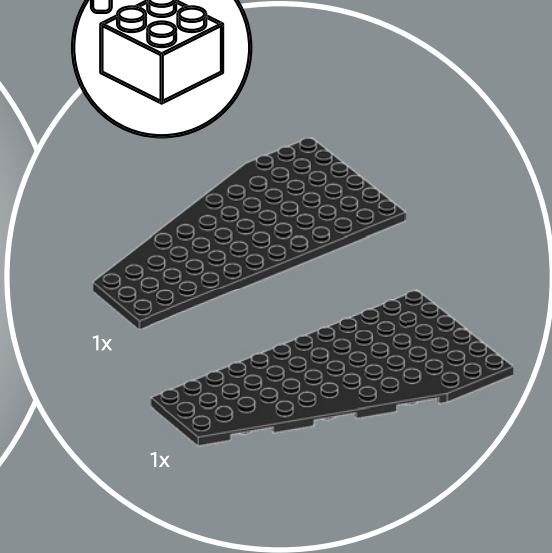
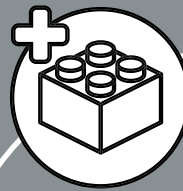

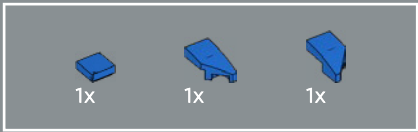

214

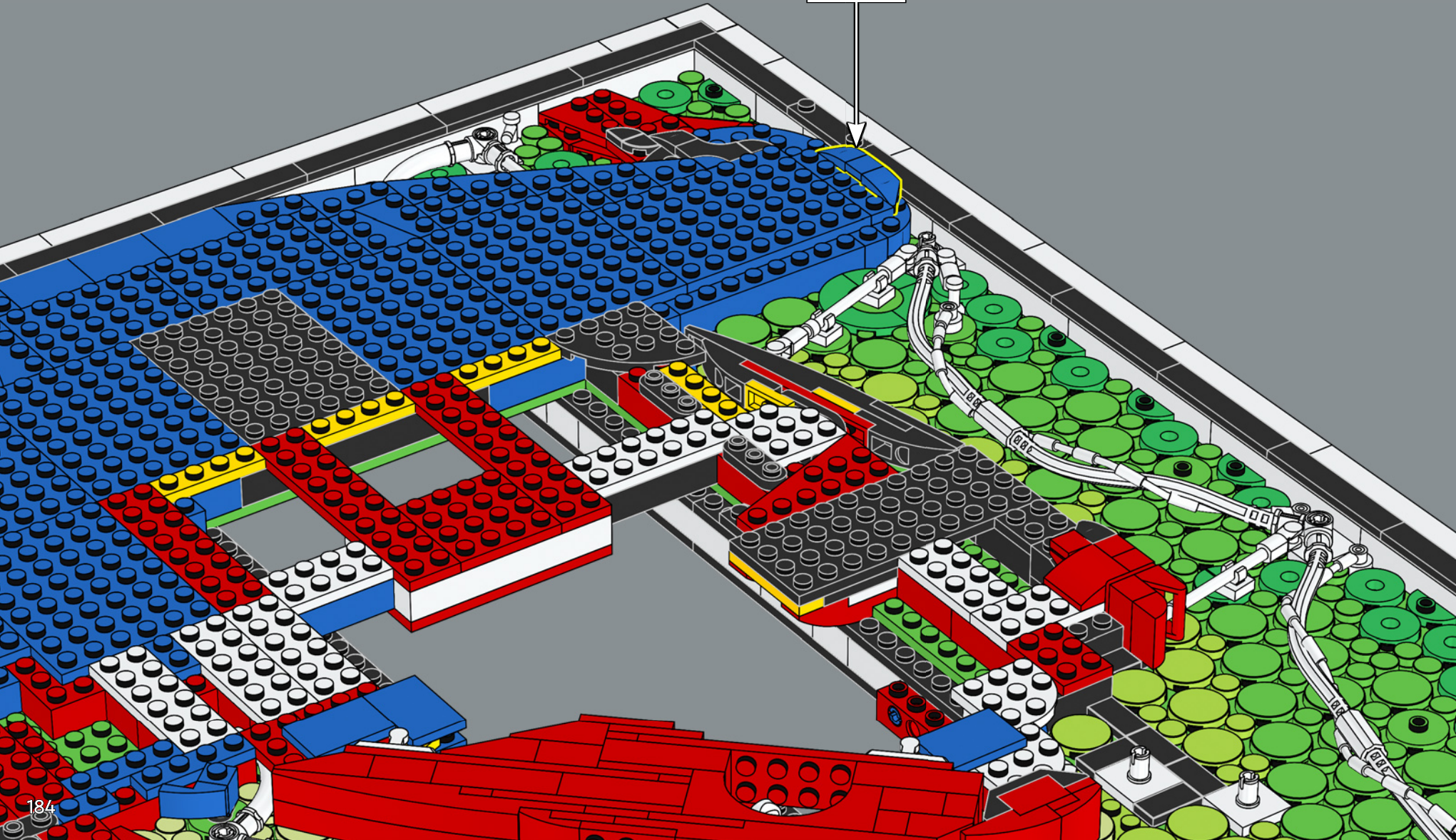



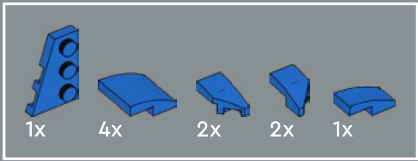

215

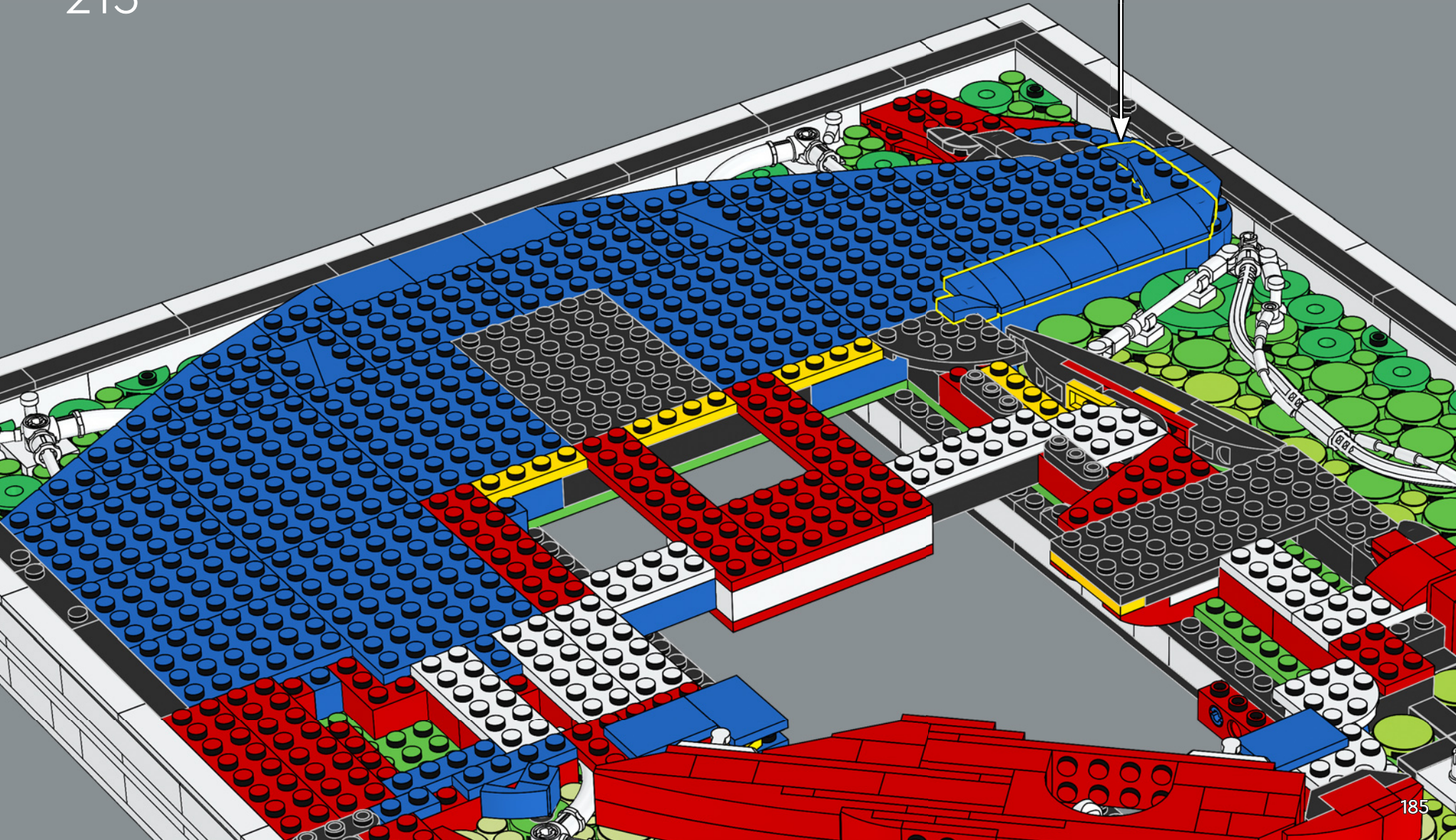

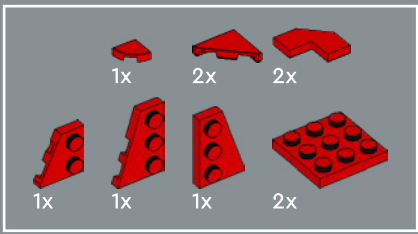

216

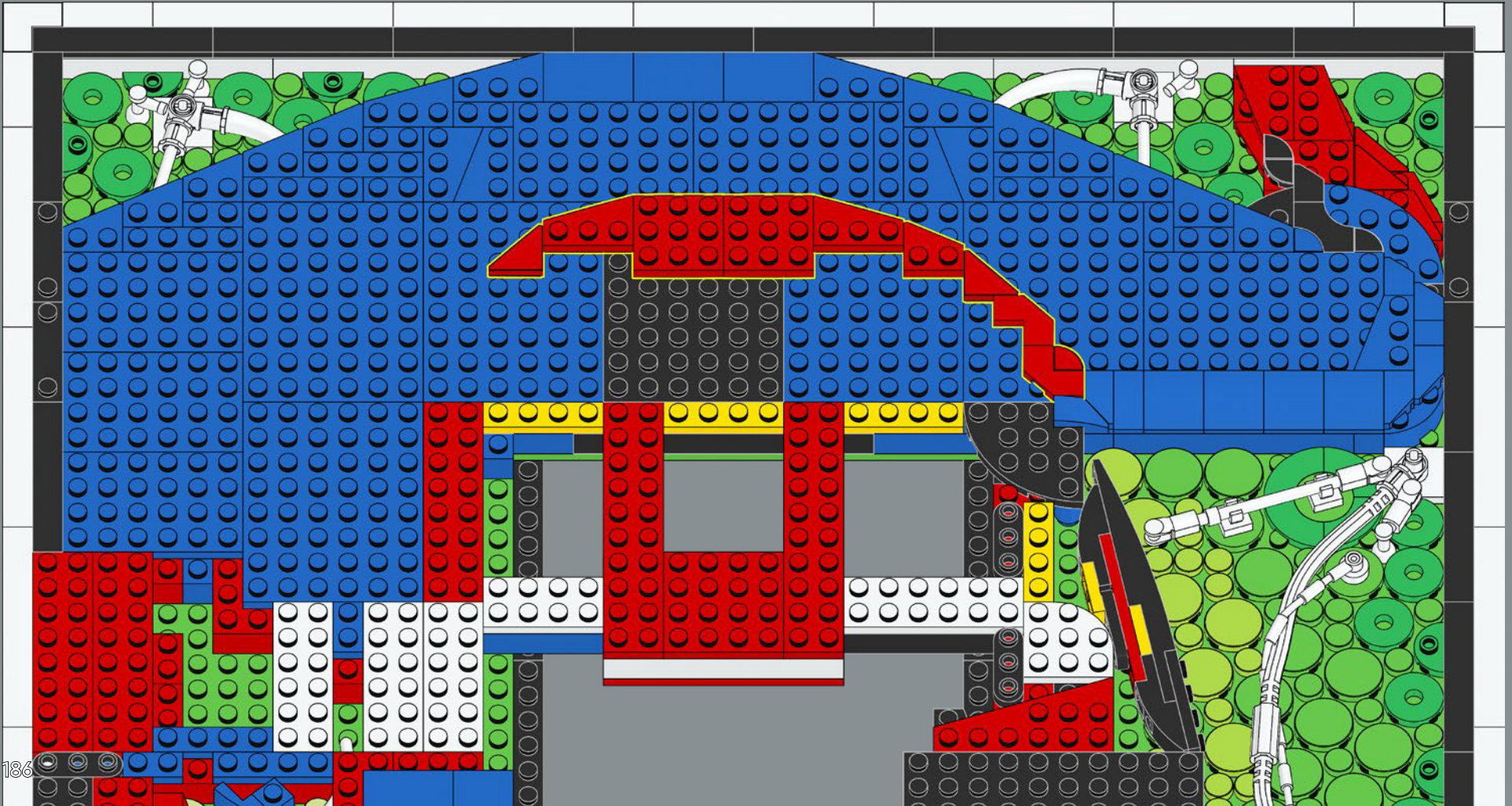

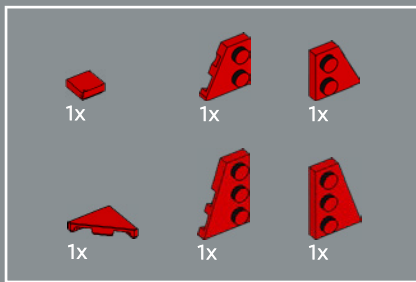

Did you know? Spider-Man stores extra web fluid cartridges on his belt. The actual belt is tucked beneath his costume, so they don't get lost!

Le saviez-vous ? Spider-Man conserve des cartouches de toile fluide supplémentaires à sa ceinture. La ceinture proprement dite est glissée sous son costume, pour ne rien perdre !

¿Lo sabías? Spider-Man guarda cartuchos adicionales de líquido de telarañas en su cinturón. El cinturón está metido debajo del traje, ¡para que no se pierdan!

217

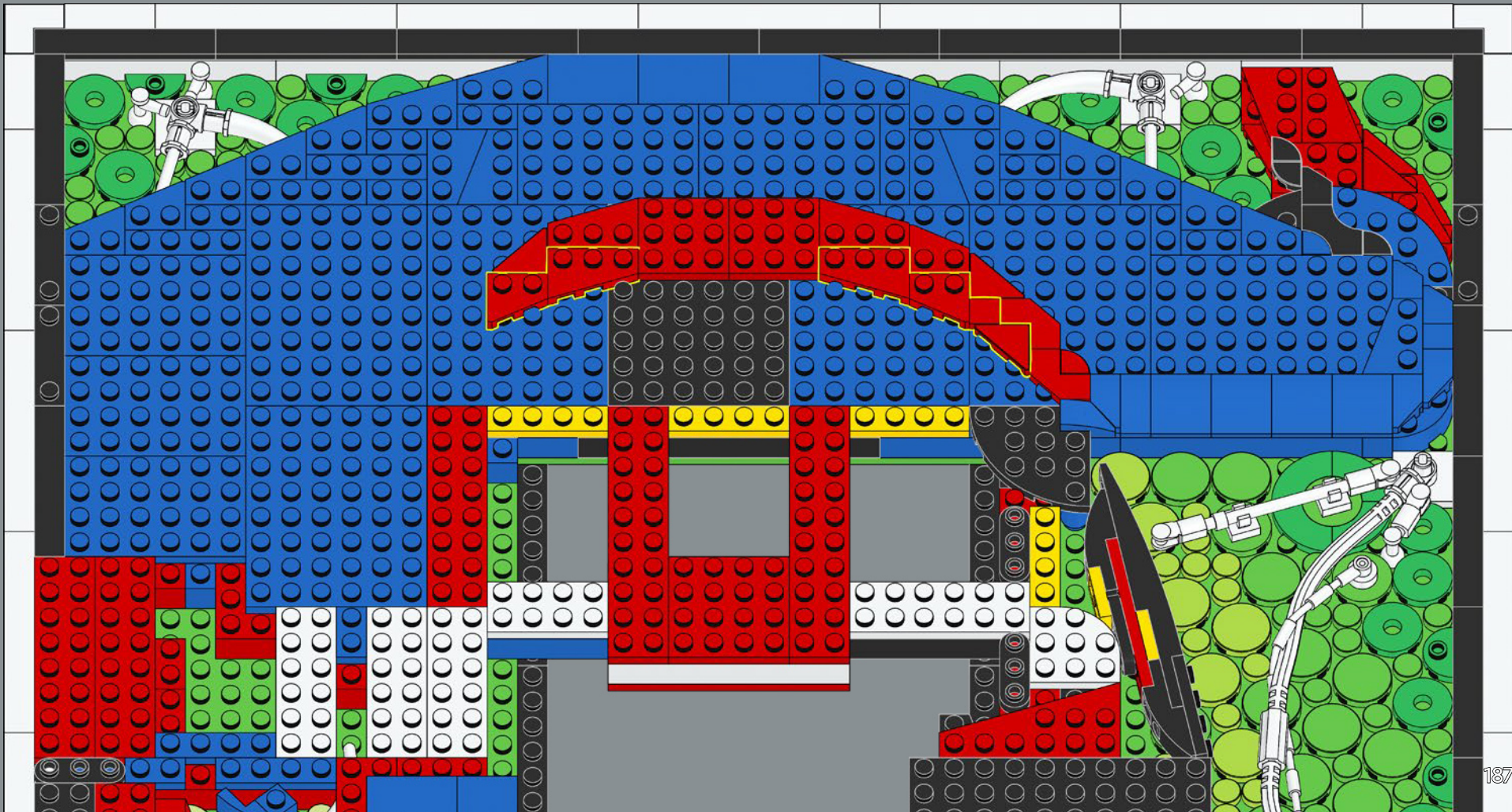



218

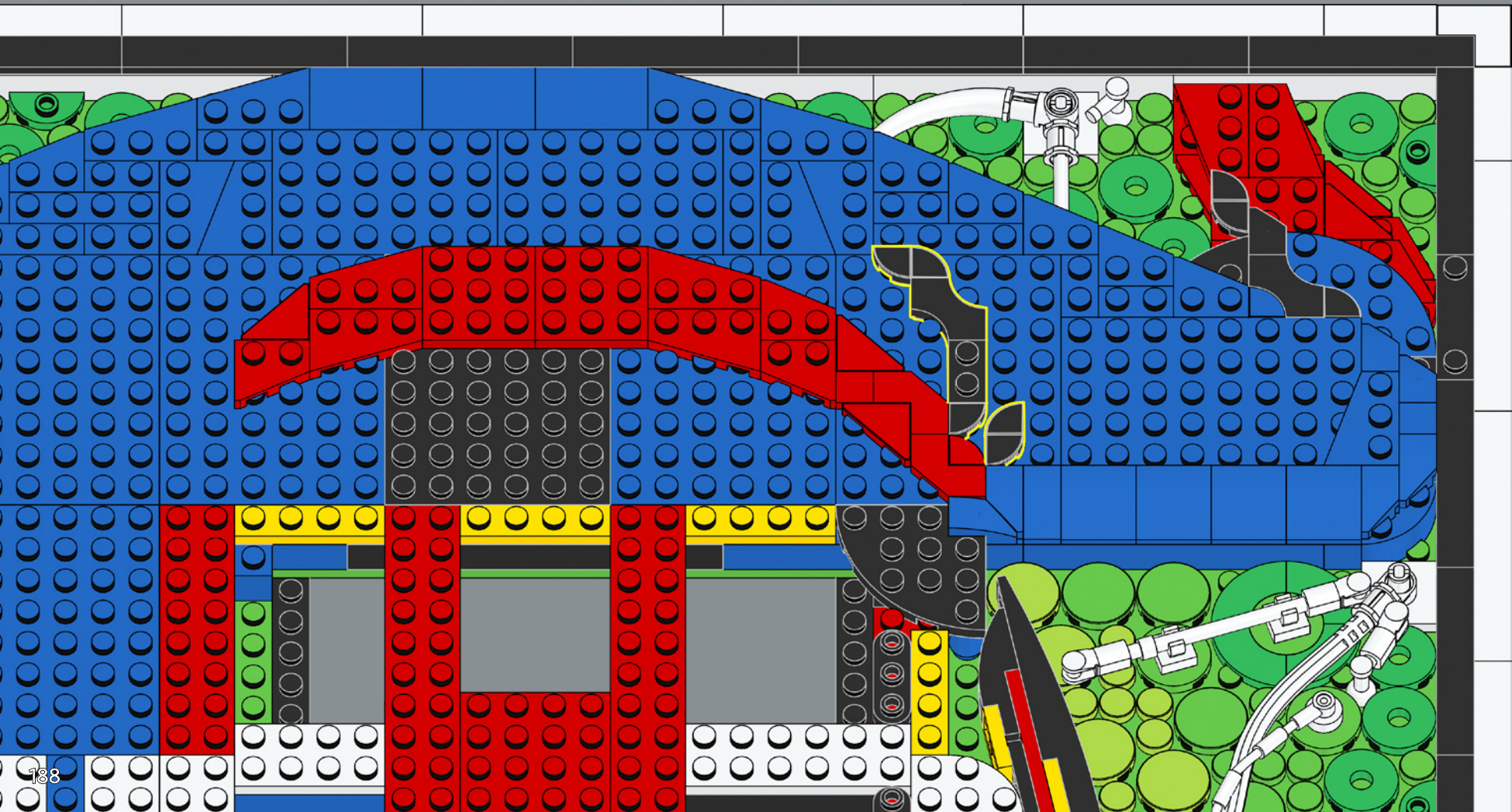

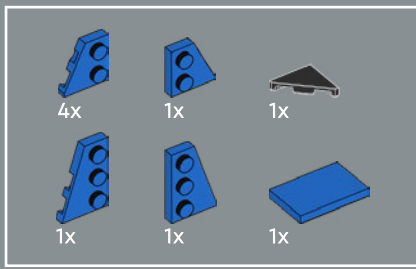

219



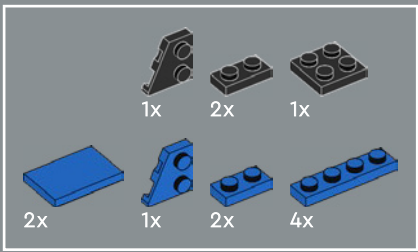

220

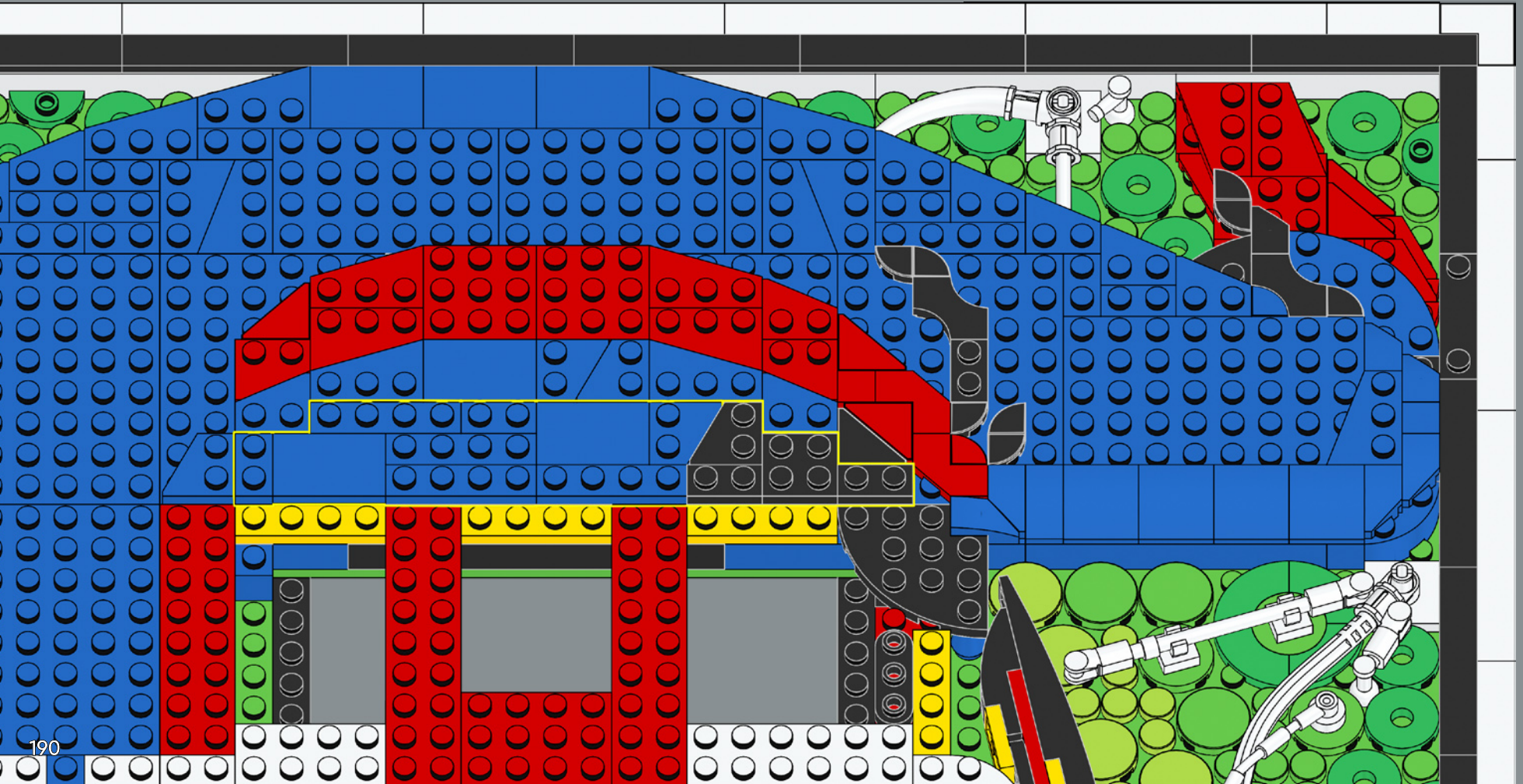

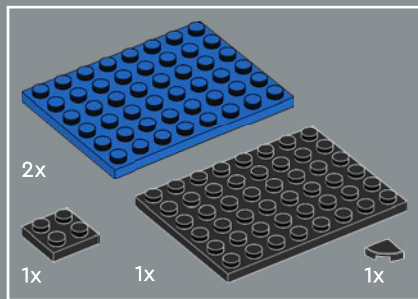

221

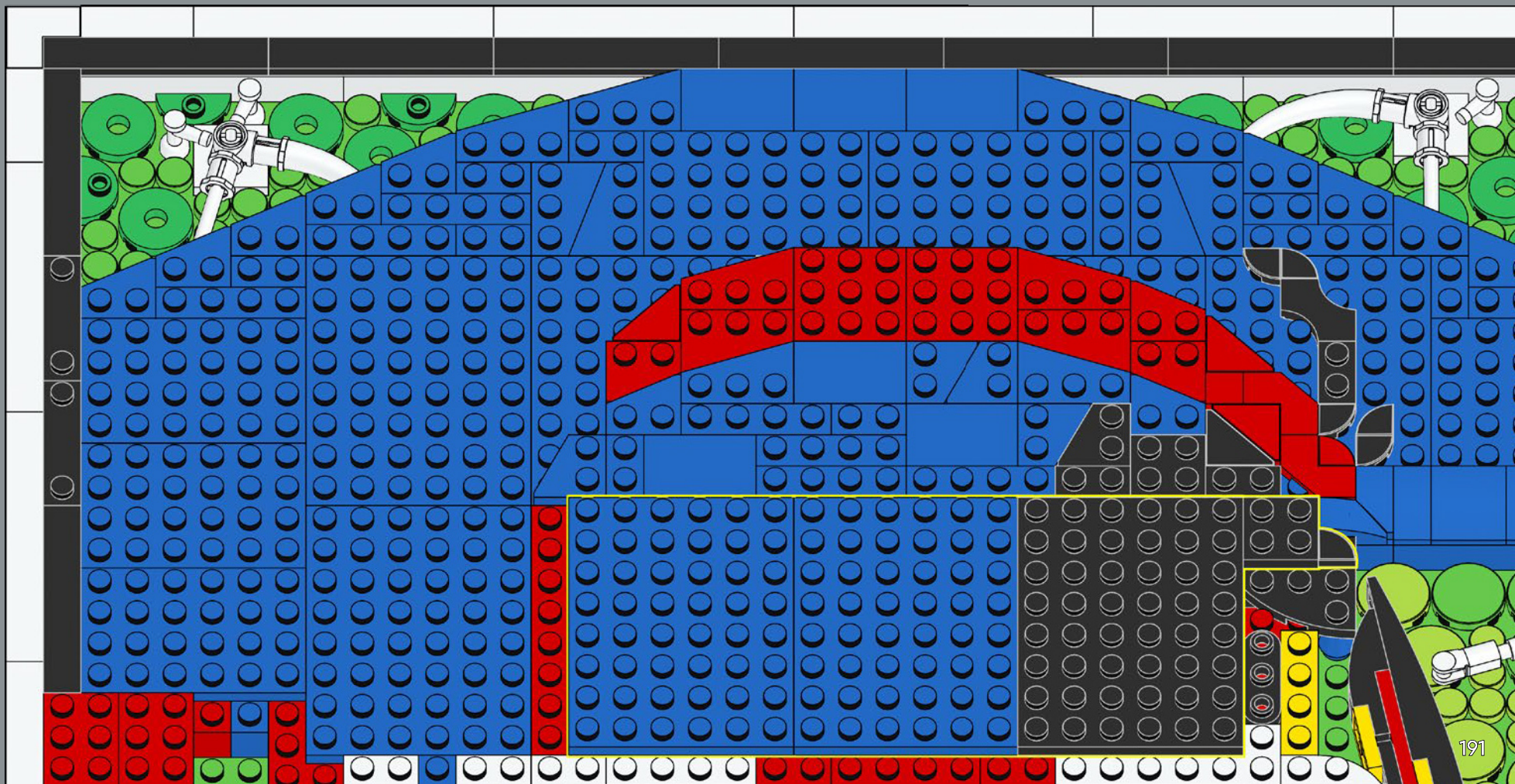

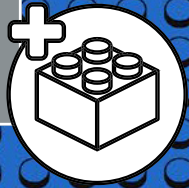
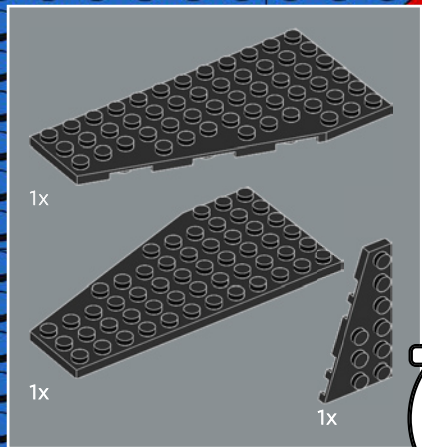

222



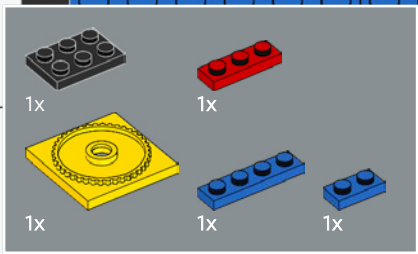

223

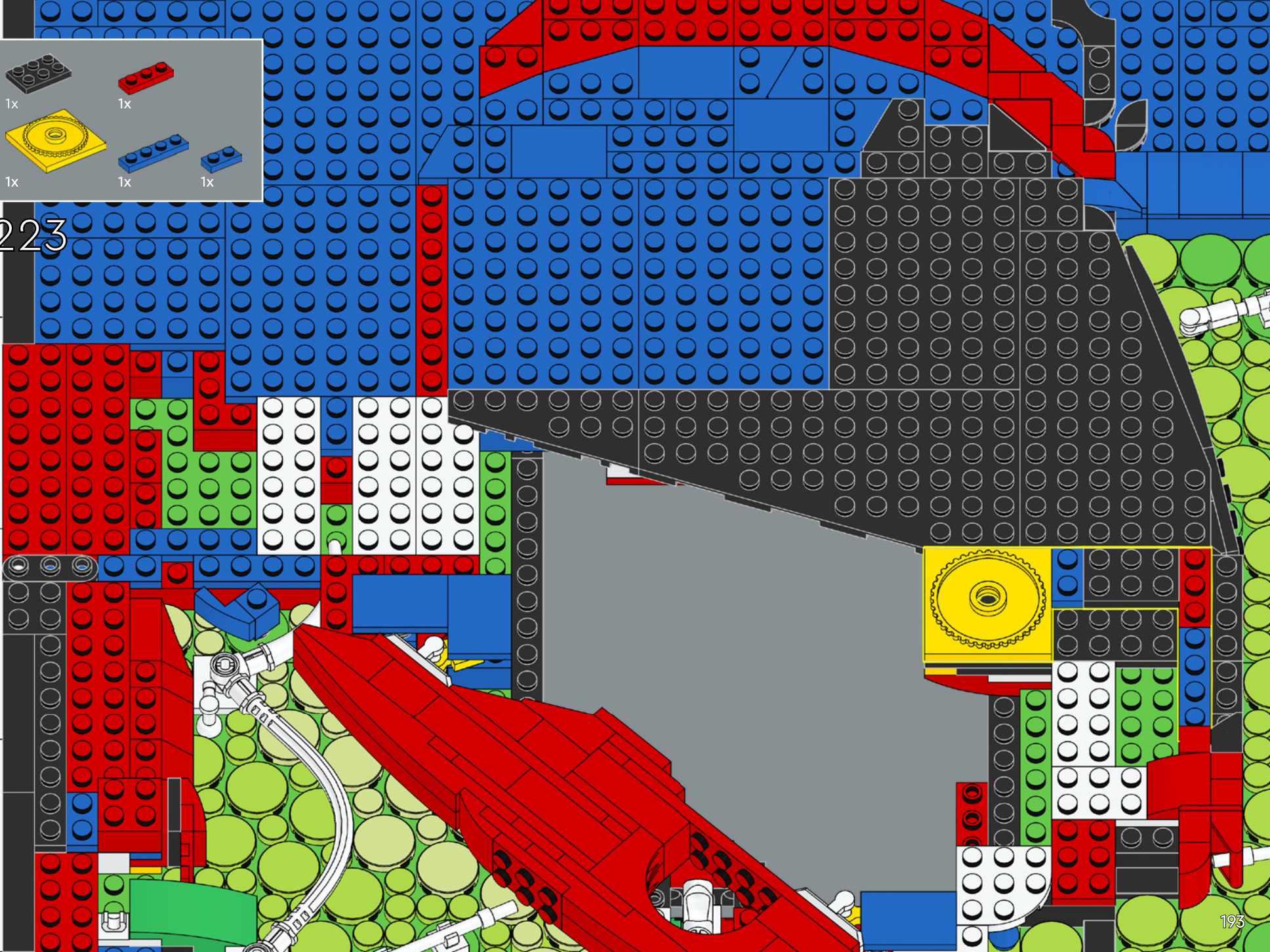

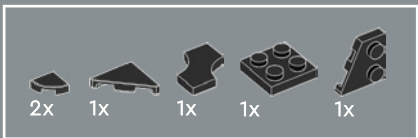

224

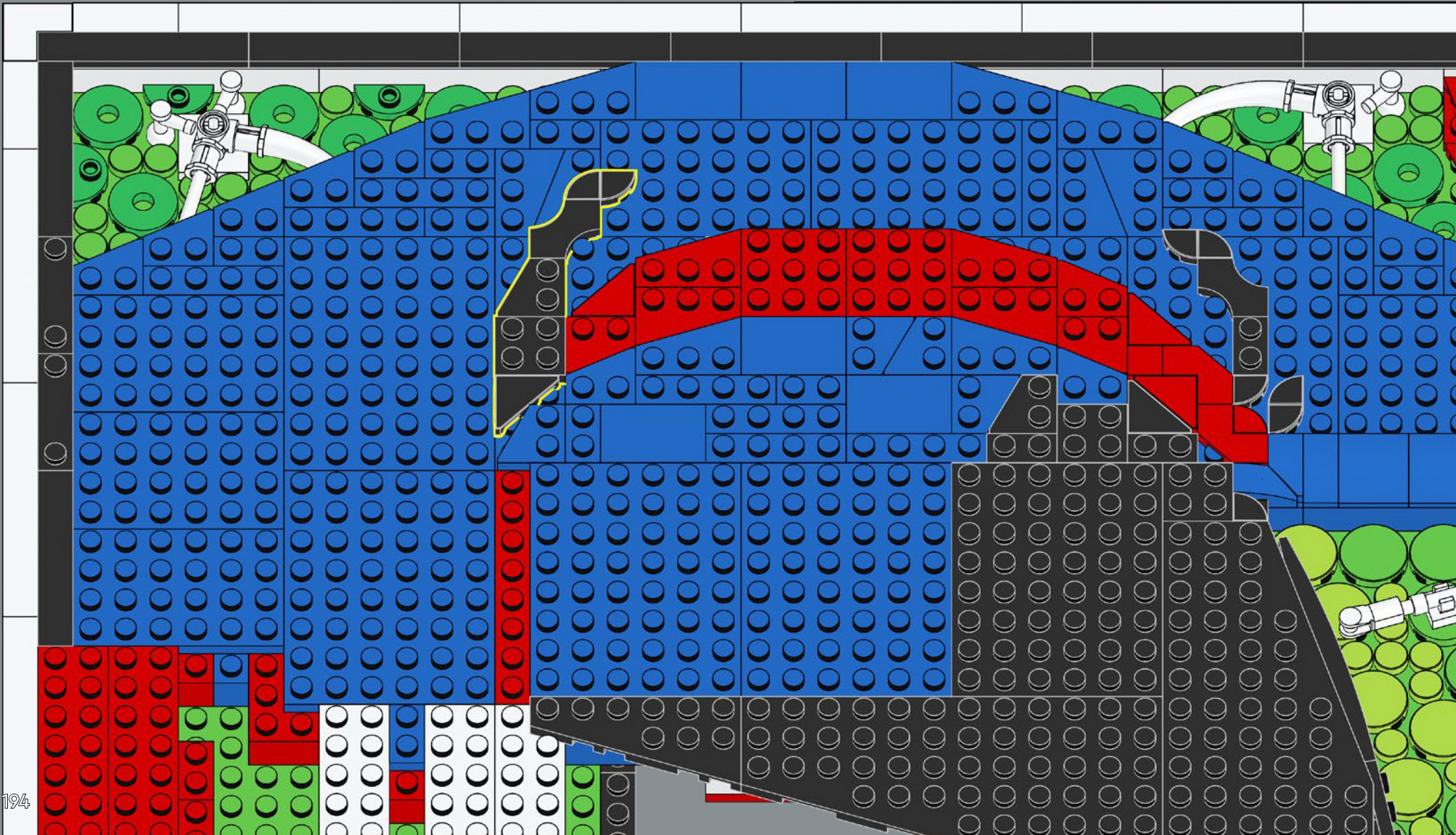

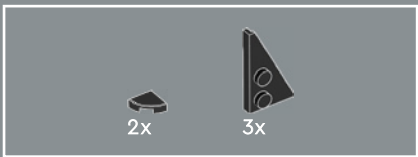

225

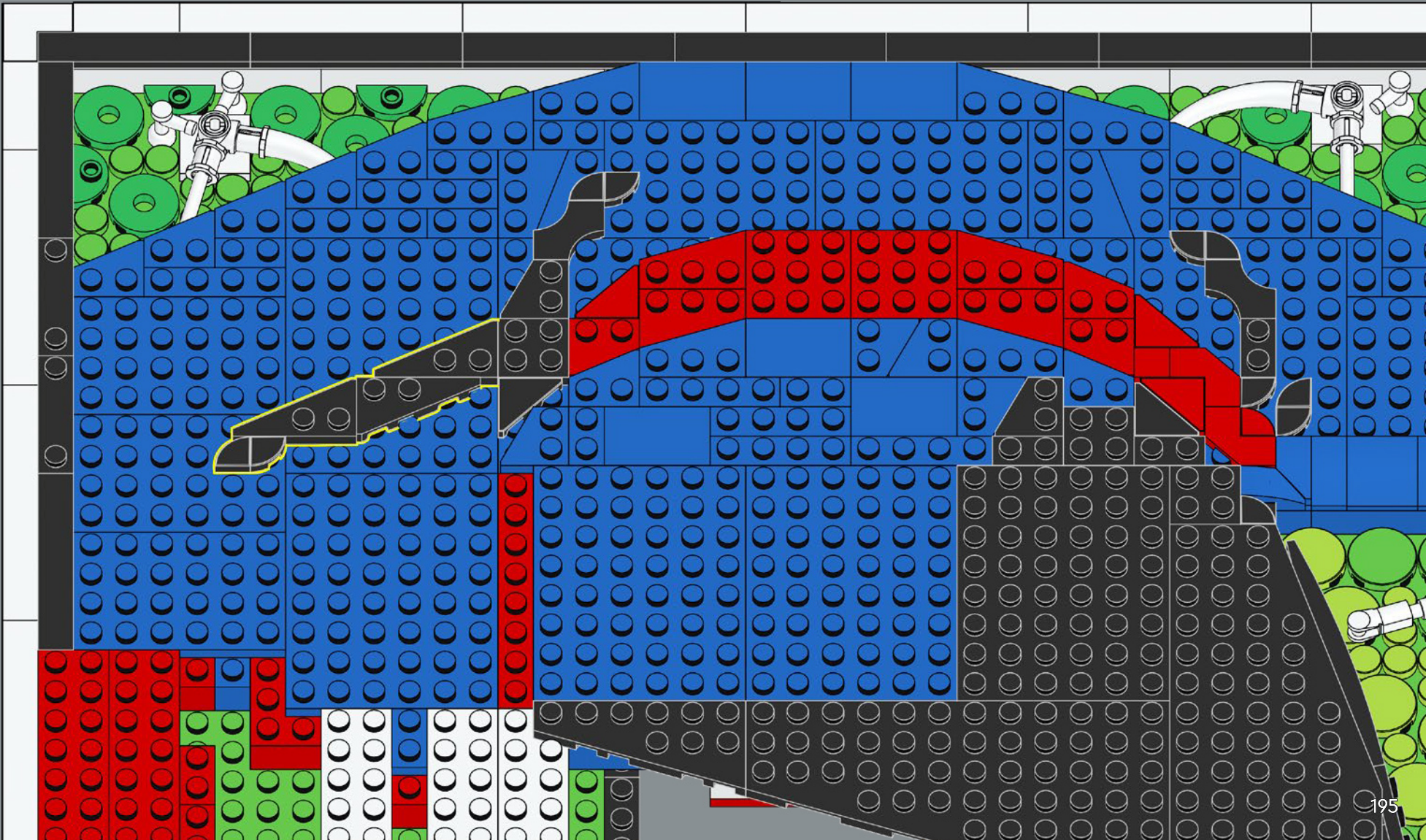

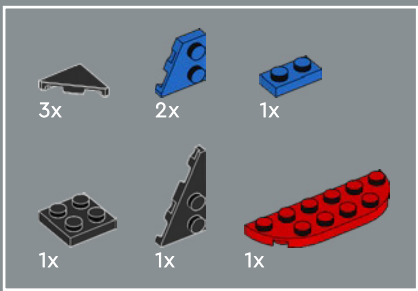

226

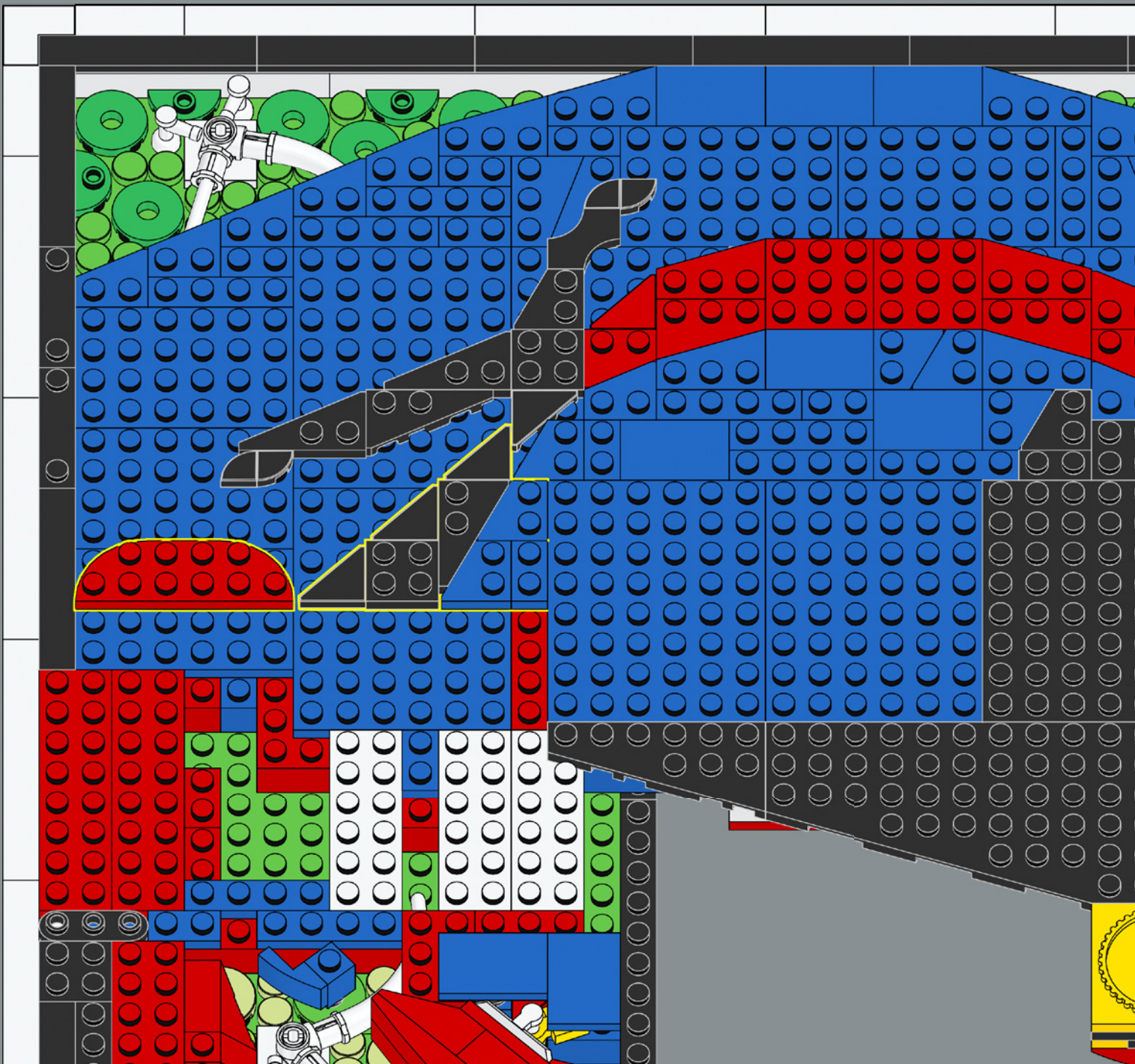

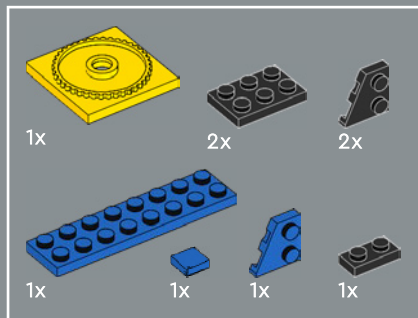

227

The placement of these yellow turntables is important! Precisely **18 across** and **3 up** ...

L'emplacement de ces platines jaunes est important ! Précisément **18 en largeur** et **3 en hauteur**...

¡La colocación de estos platos giratorios amarillos es importante! Exactamente, **18 a lo ancho** y **3 a lo alto**...

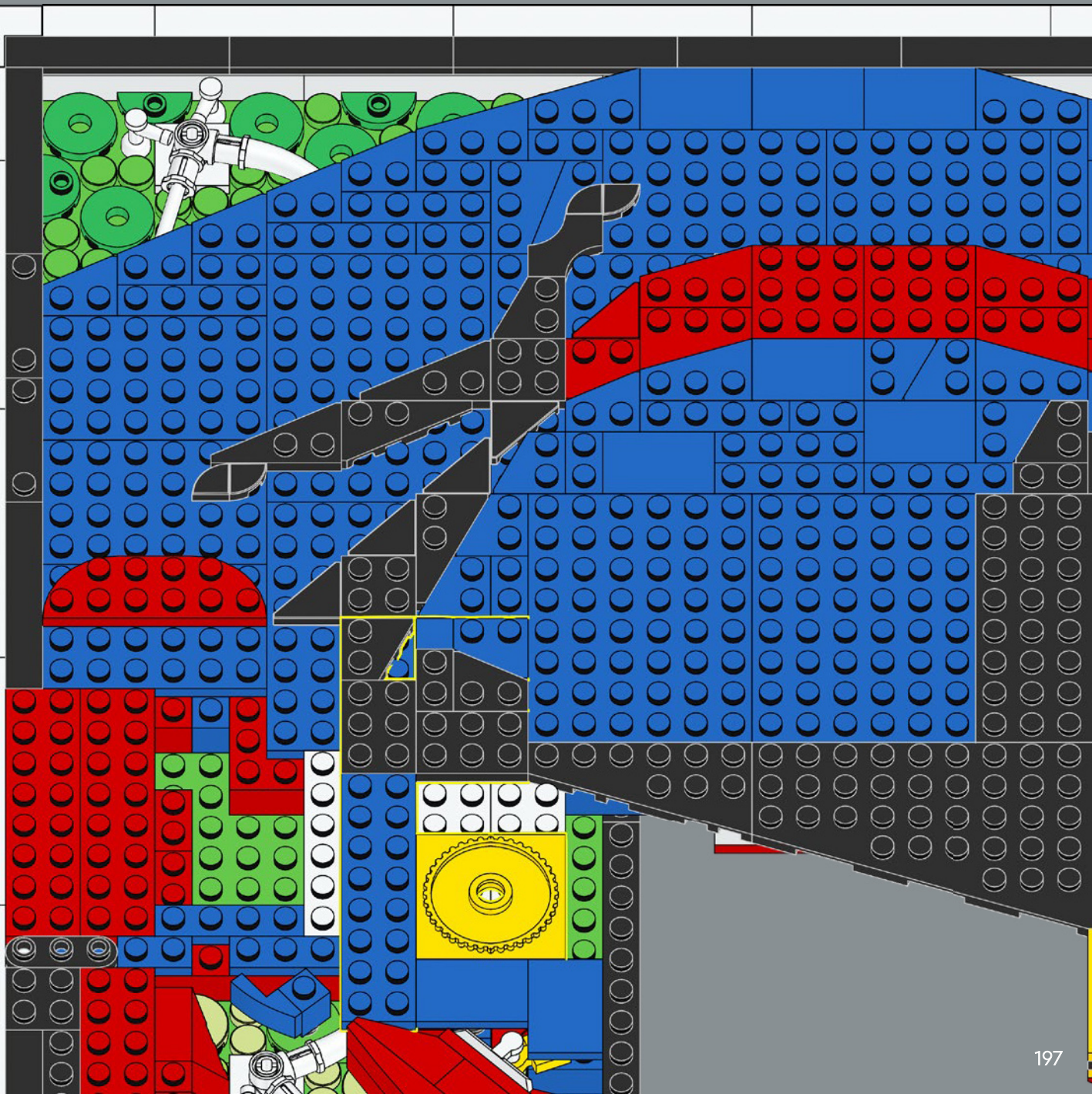

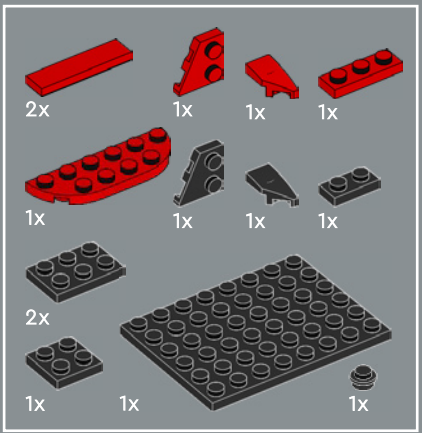

228

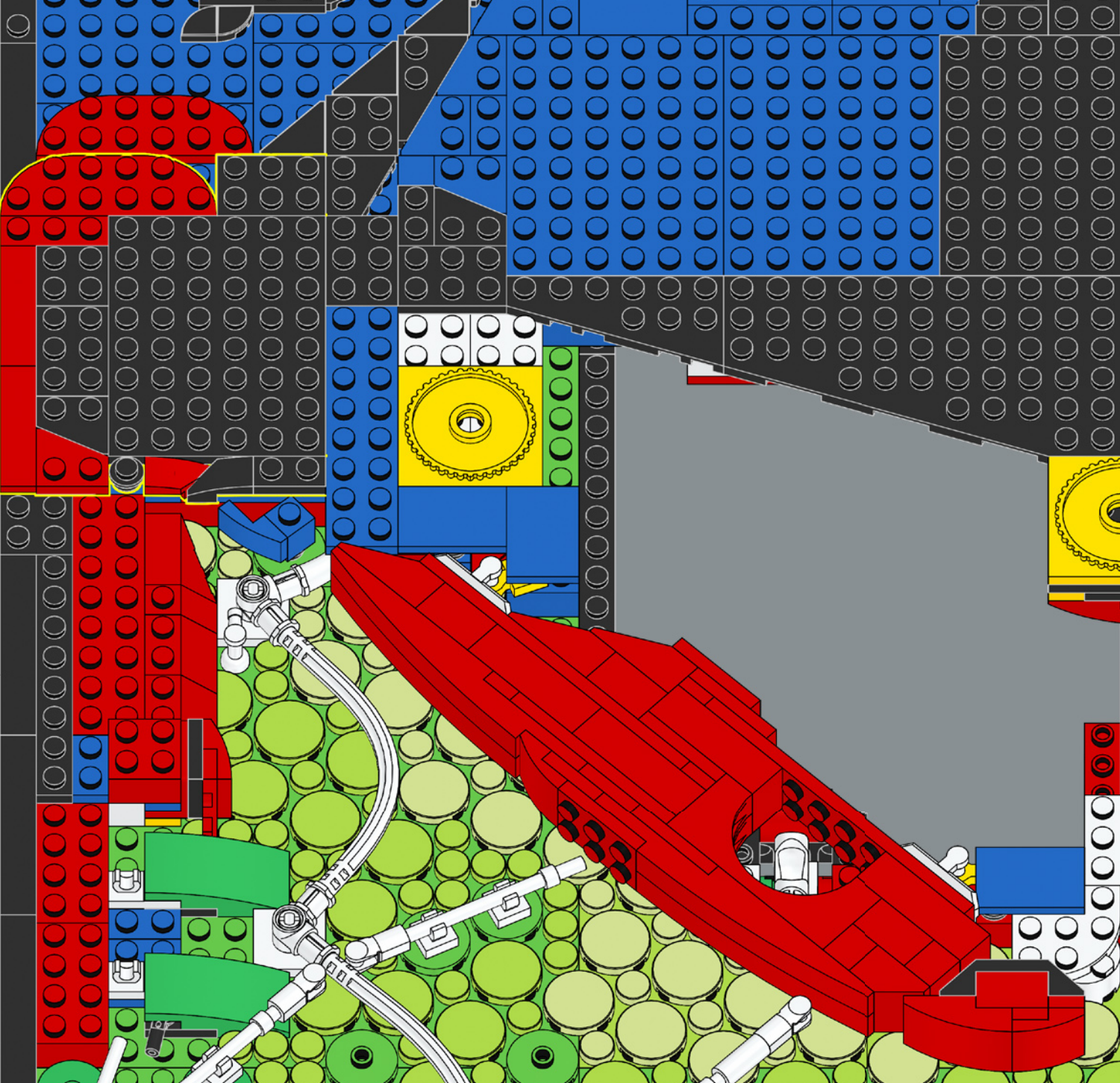

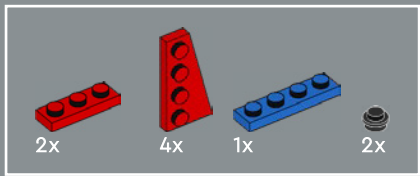

229

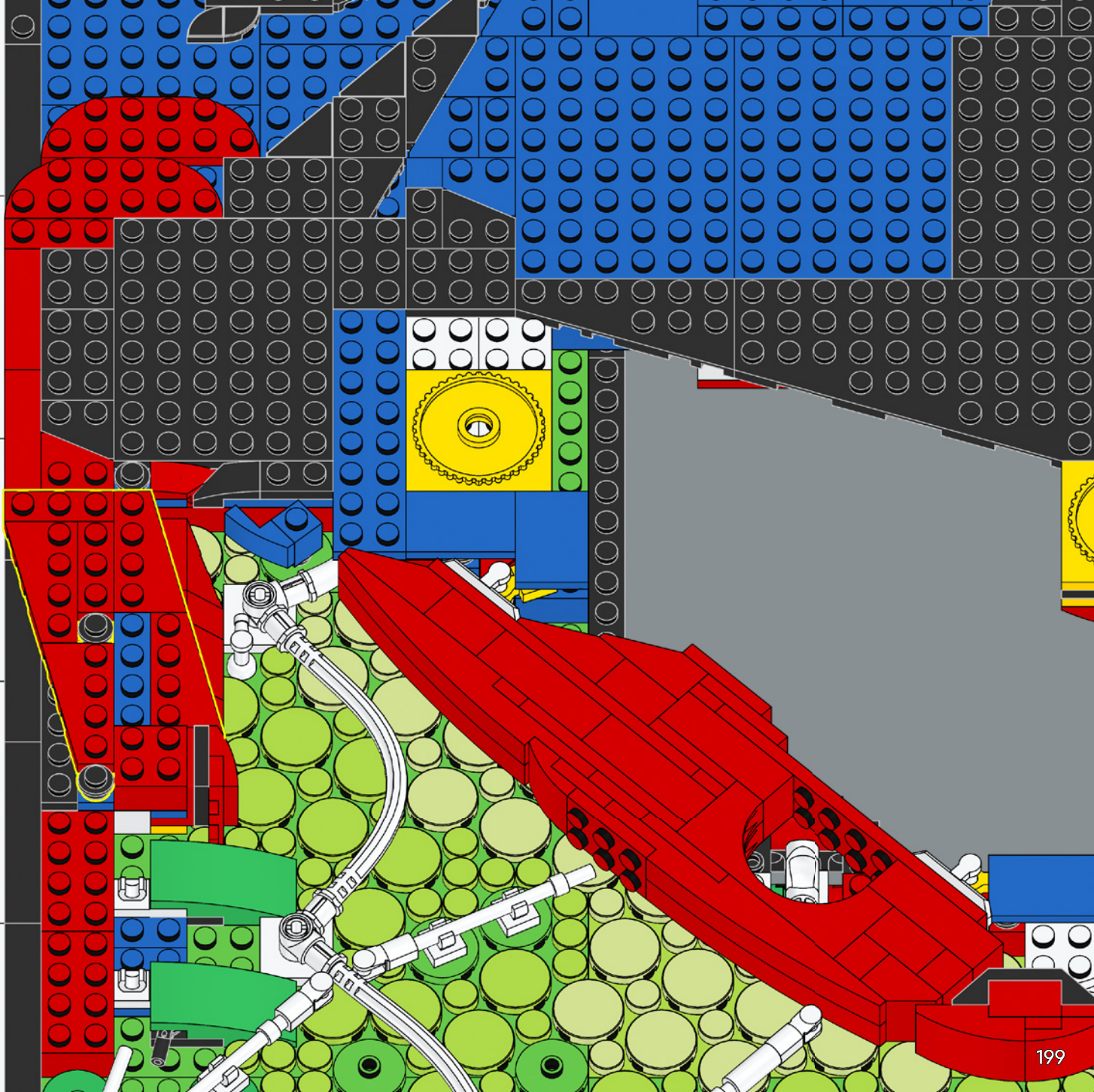





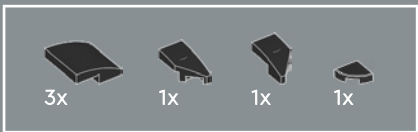

230

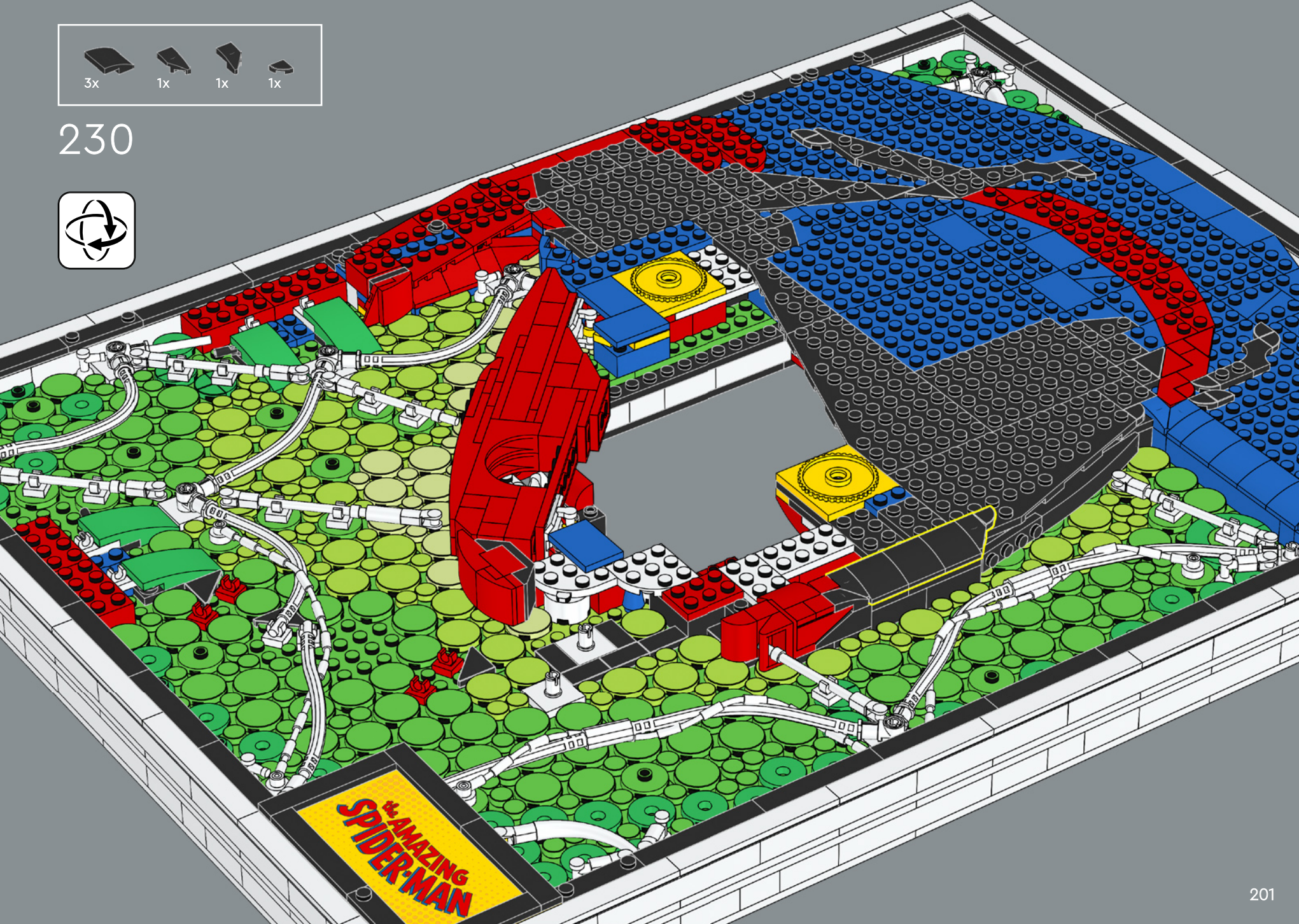

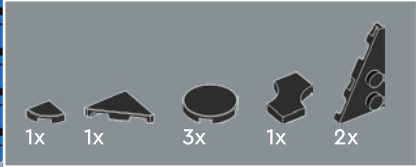

1x 1x 3x 1x 2x

This block contains a parts list for step 231. It includes five items: a small grey wedge (1x), a grey wedge with a hole (1x), a grey circular piece (3x), a grey square piece with a hole (1x), and a grey triangular piece (2x).

231

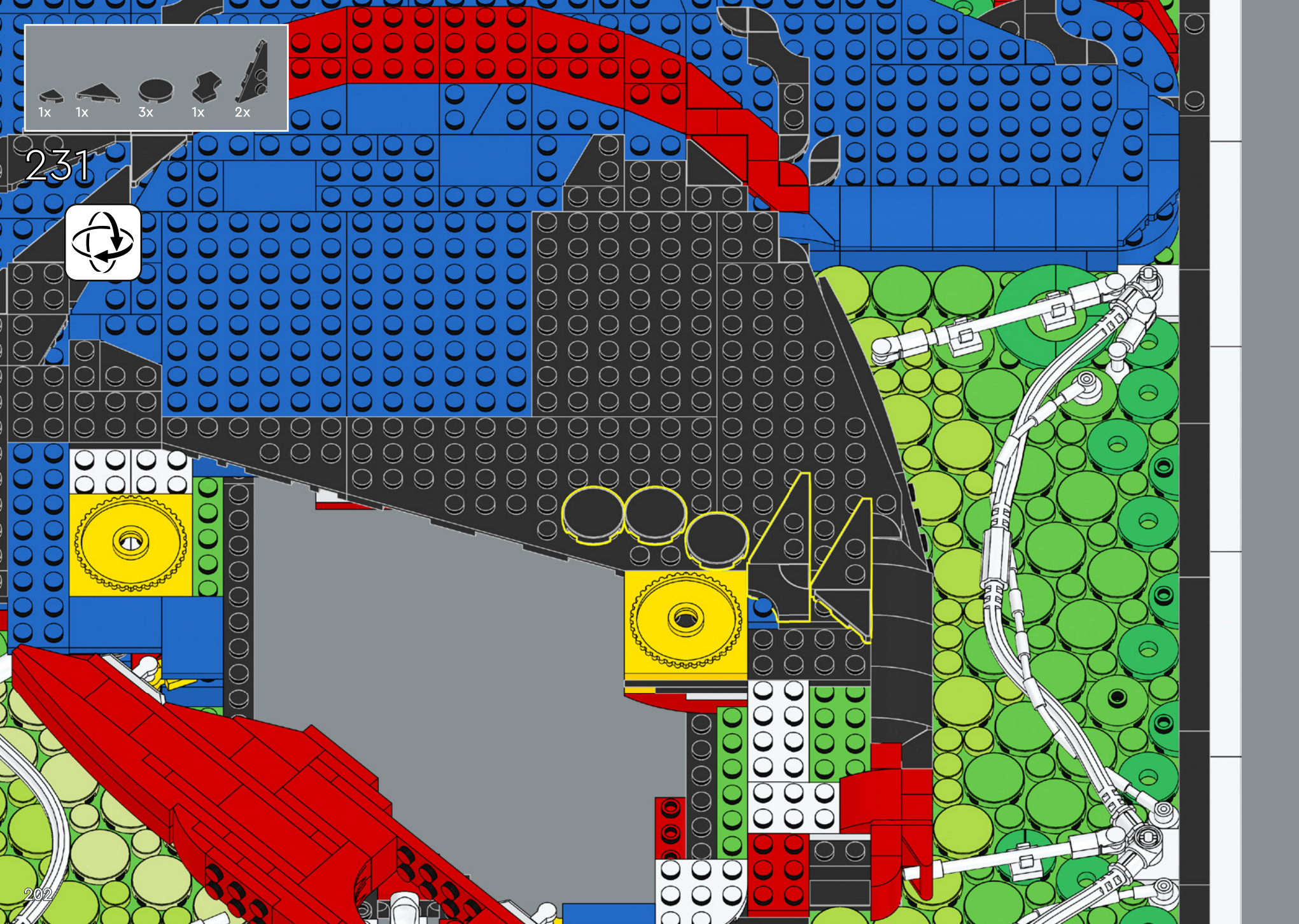

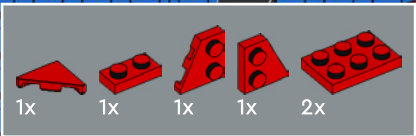

232

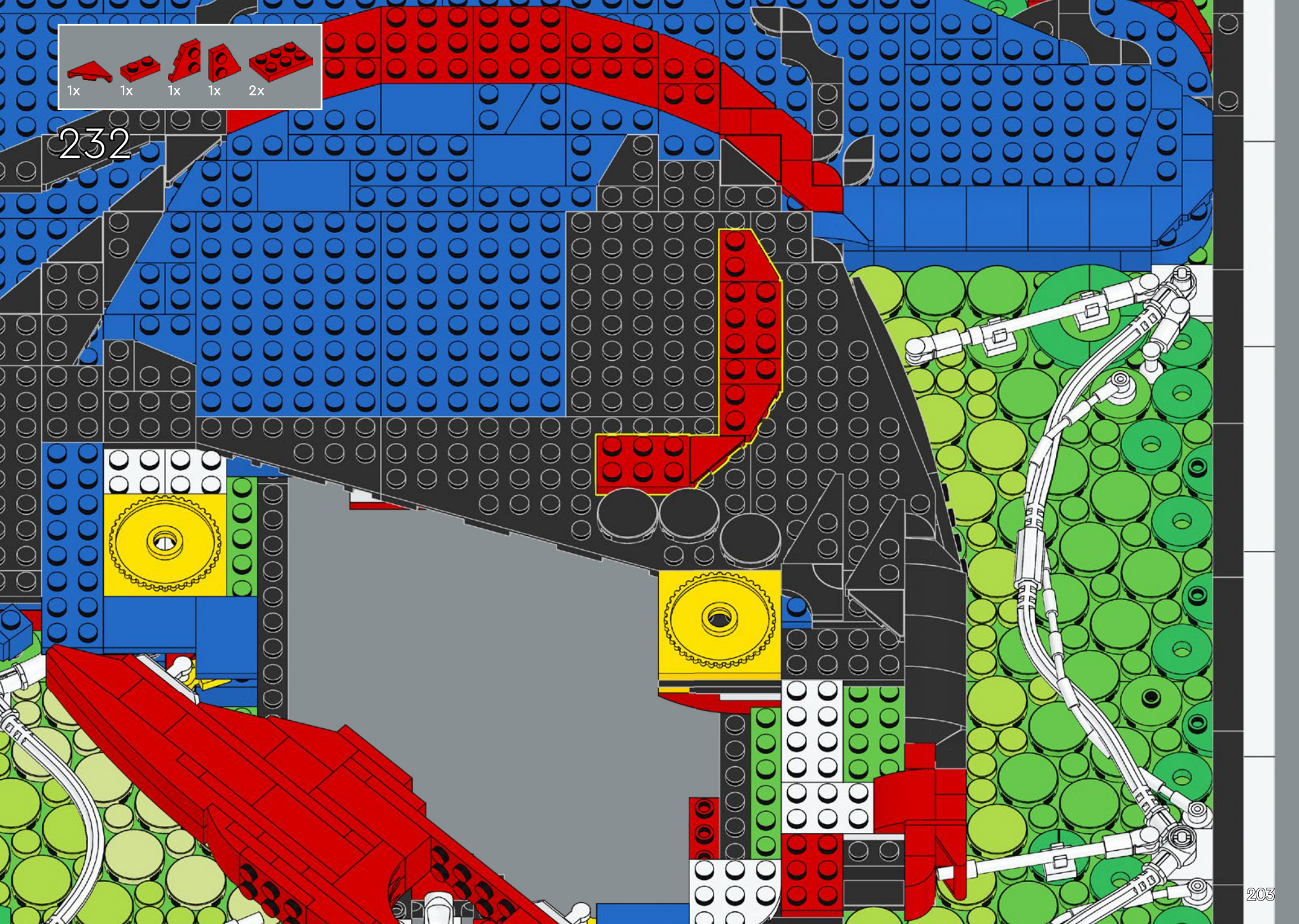

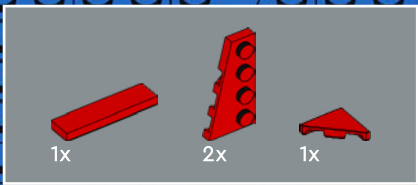

233

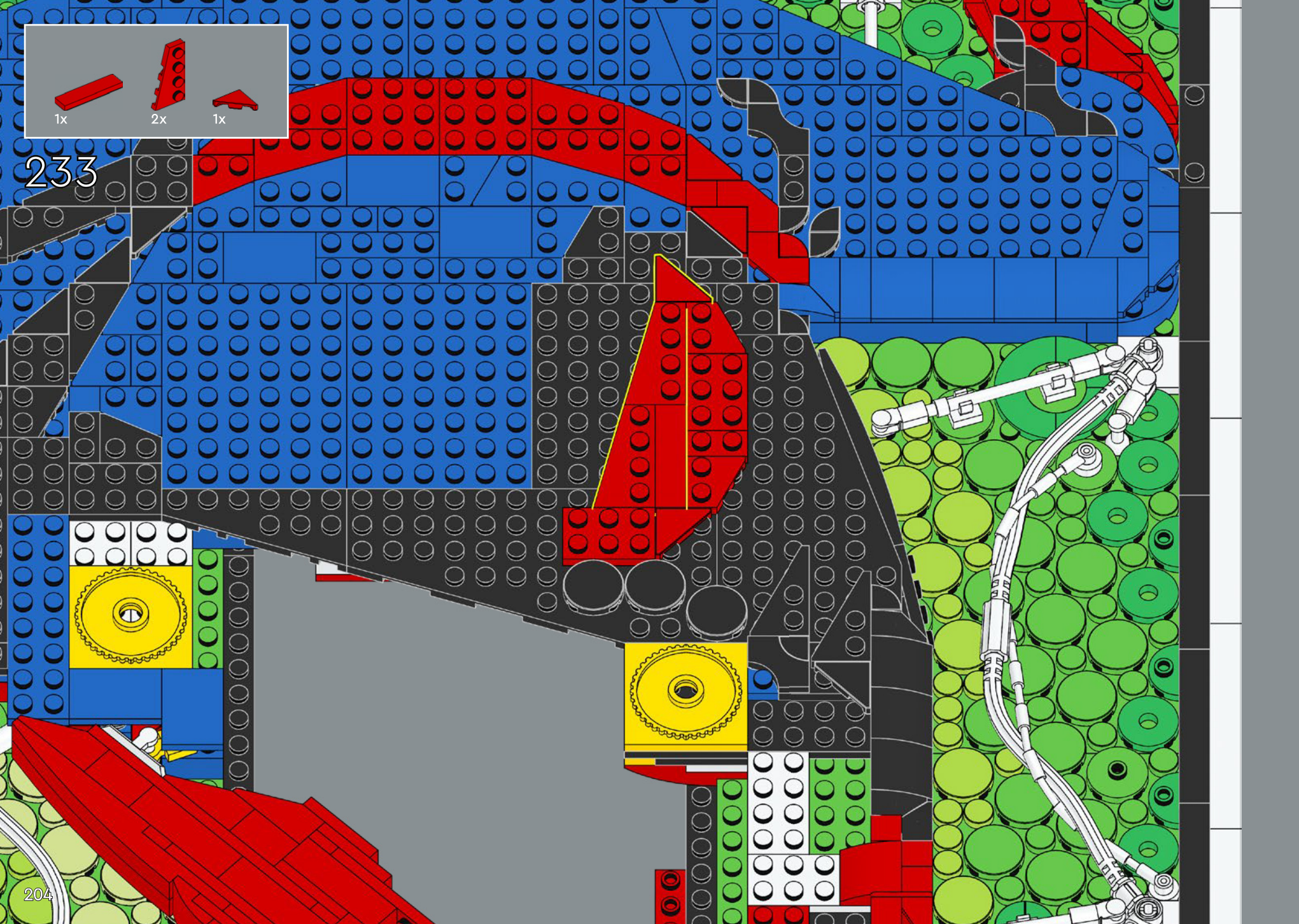

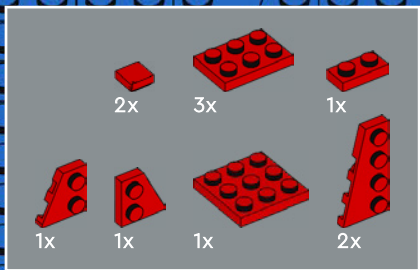

234

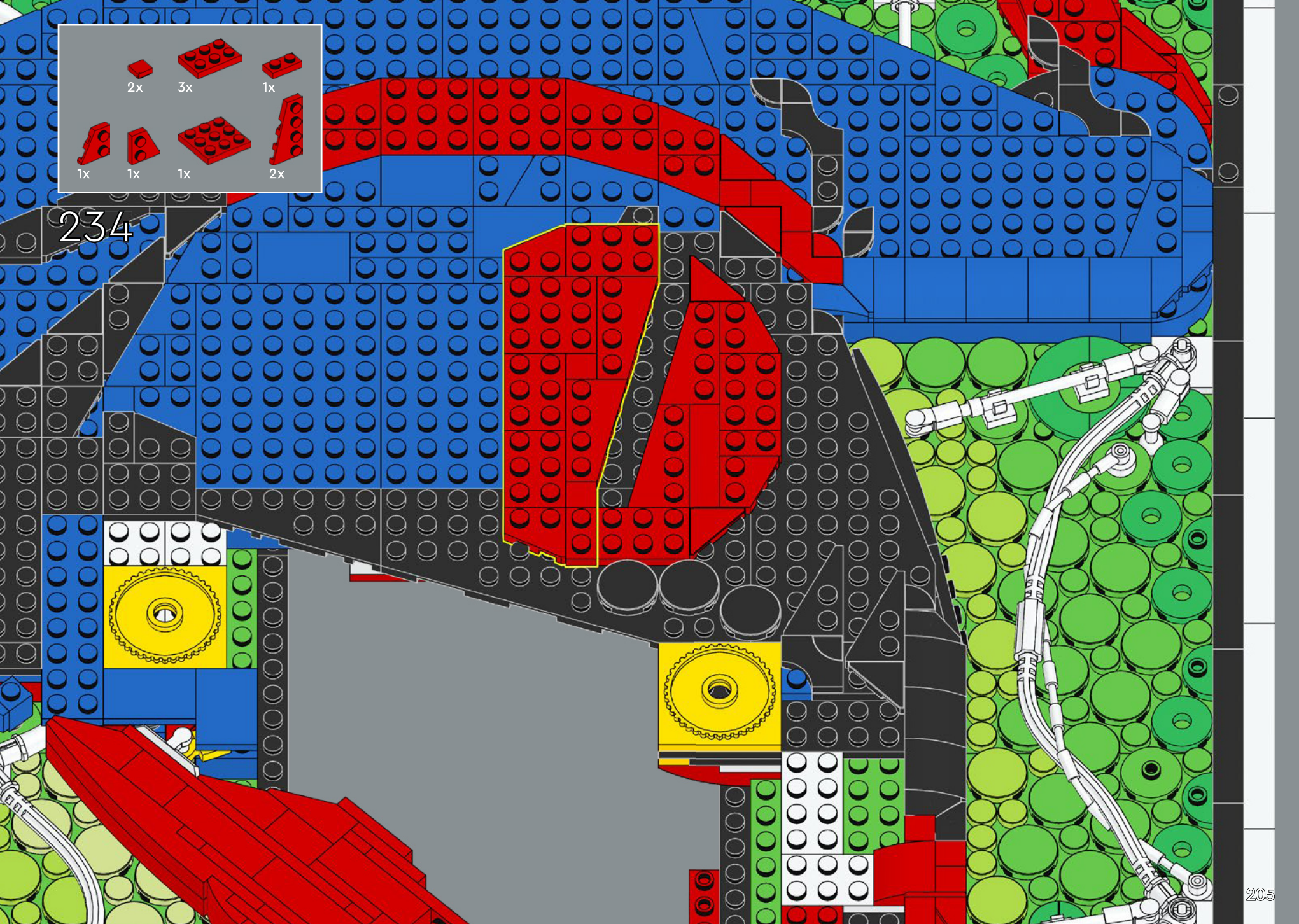



235

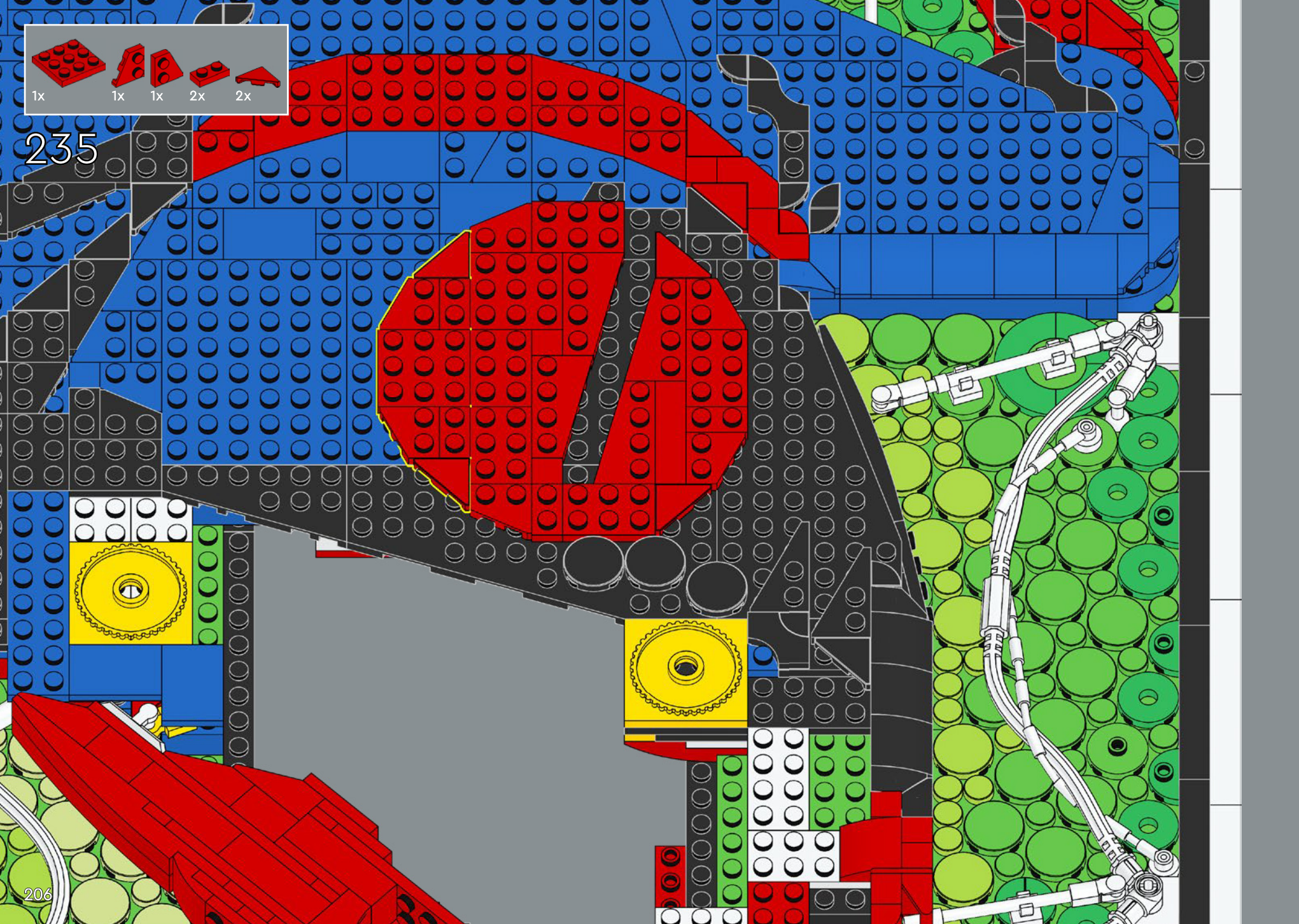

1x  3x 

236

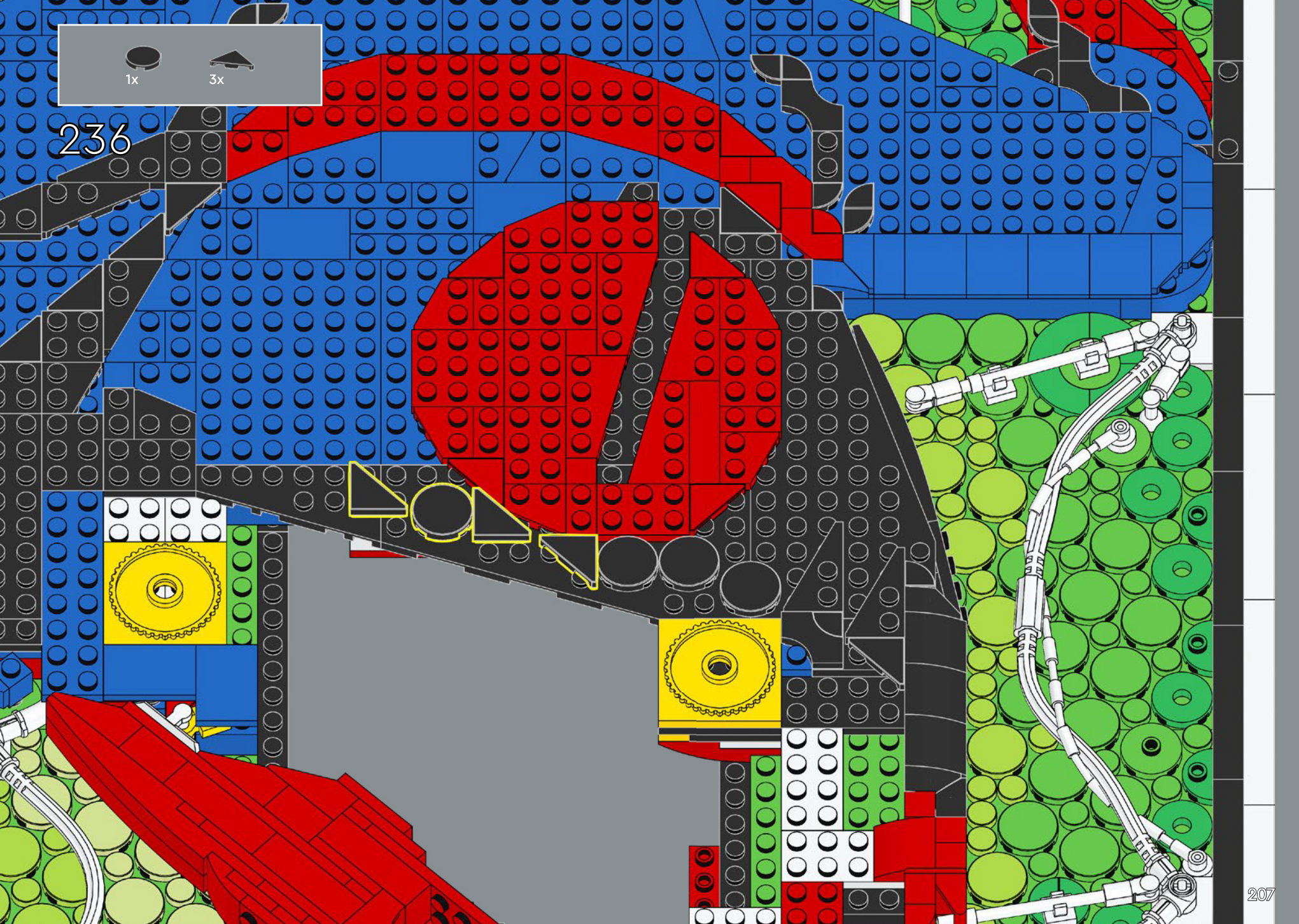

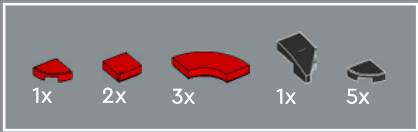

237

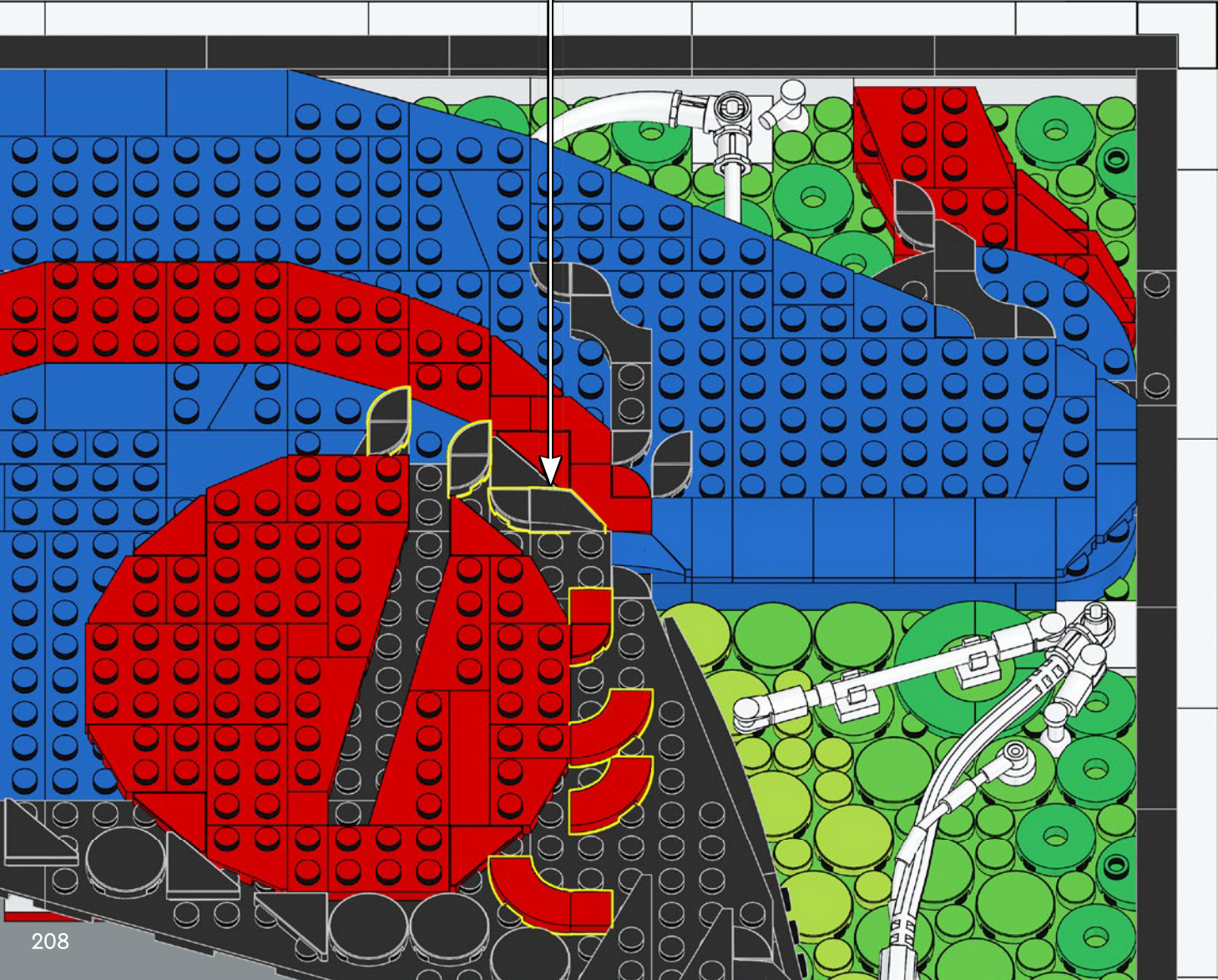



8x      4x

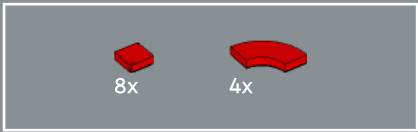

238

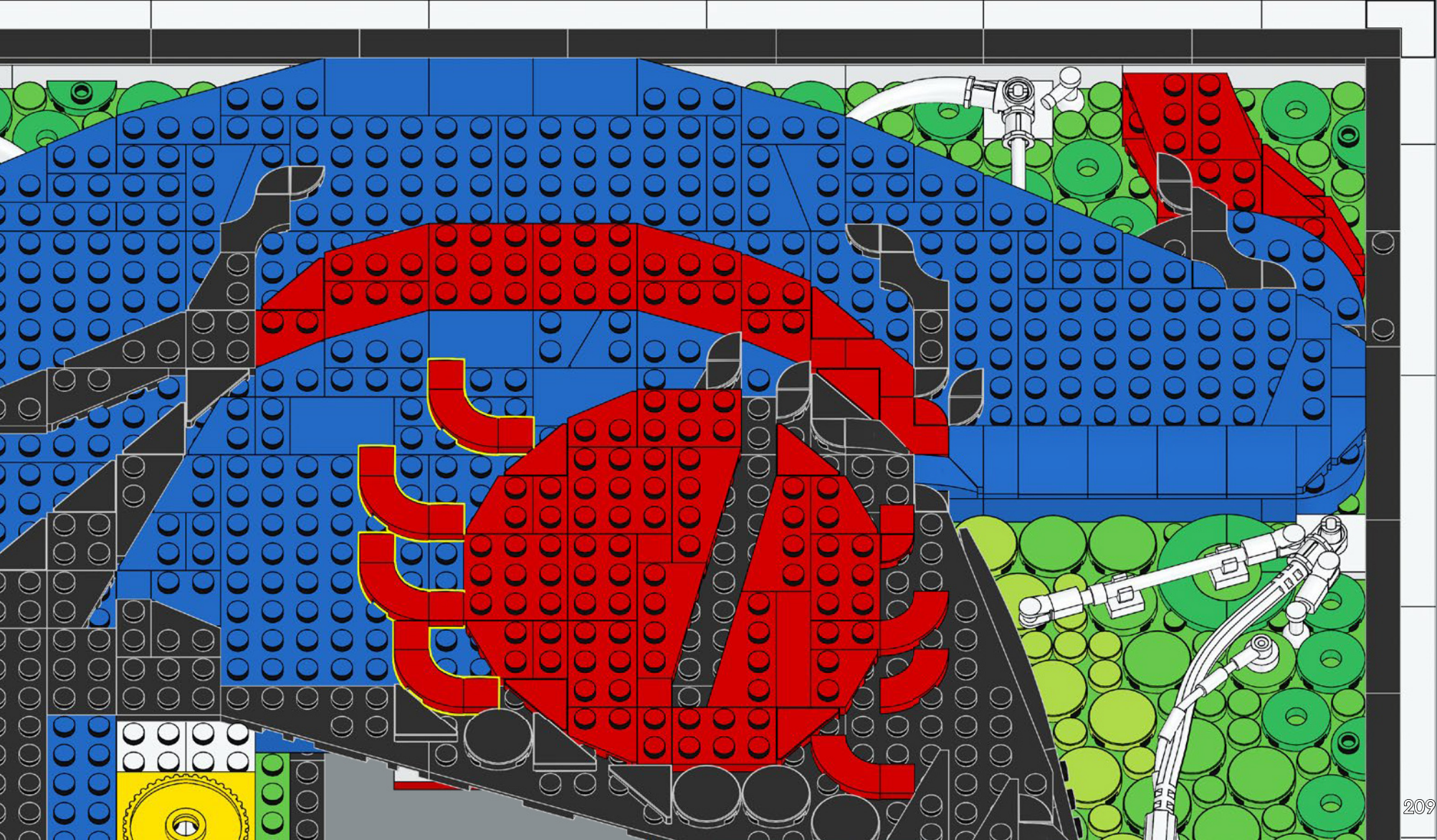

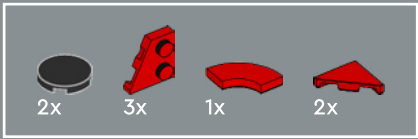

239

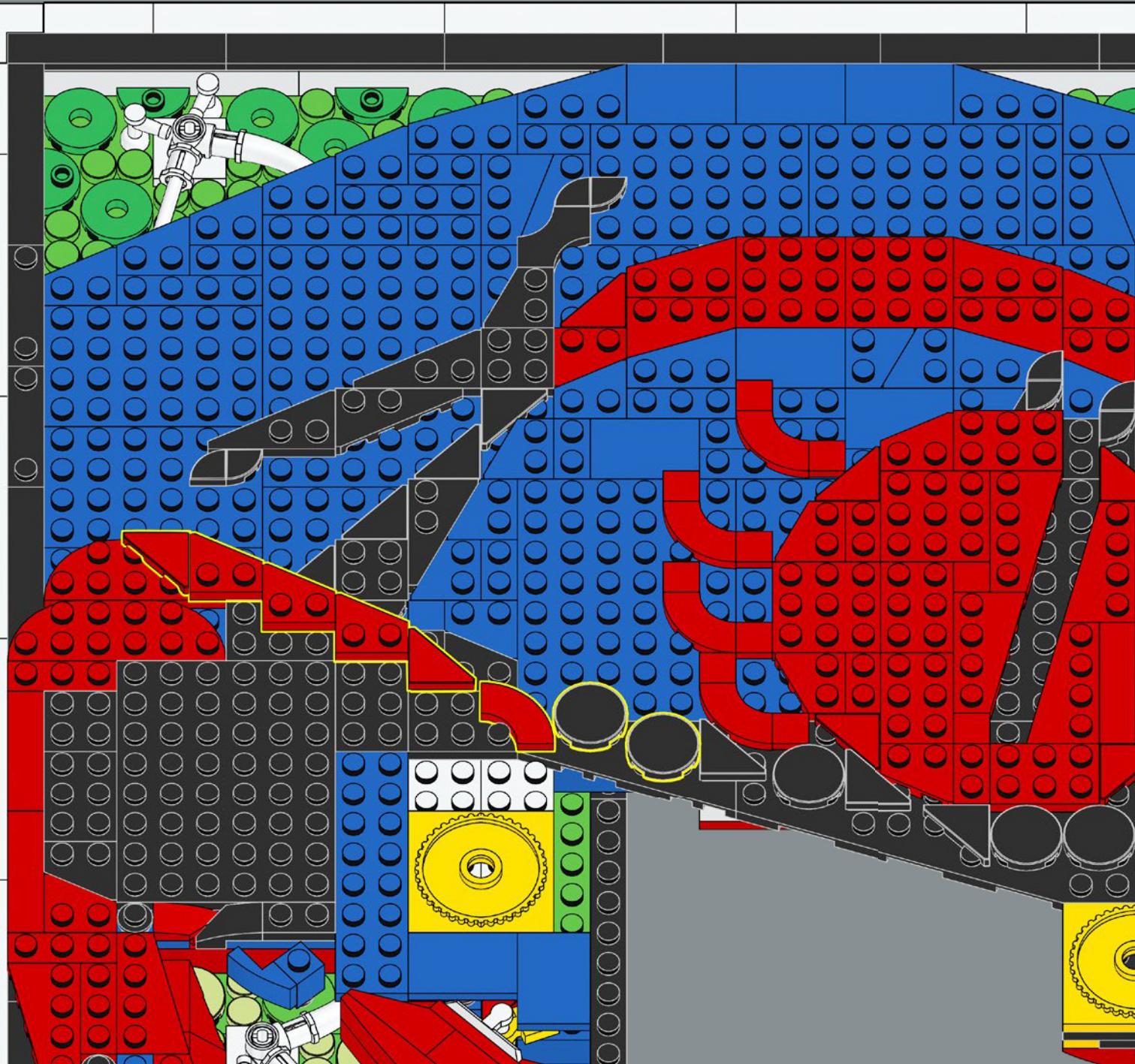

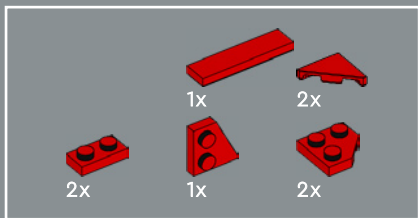

240

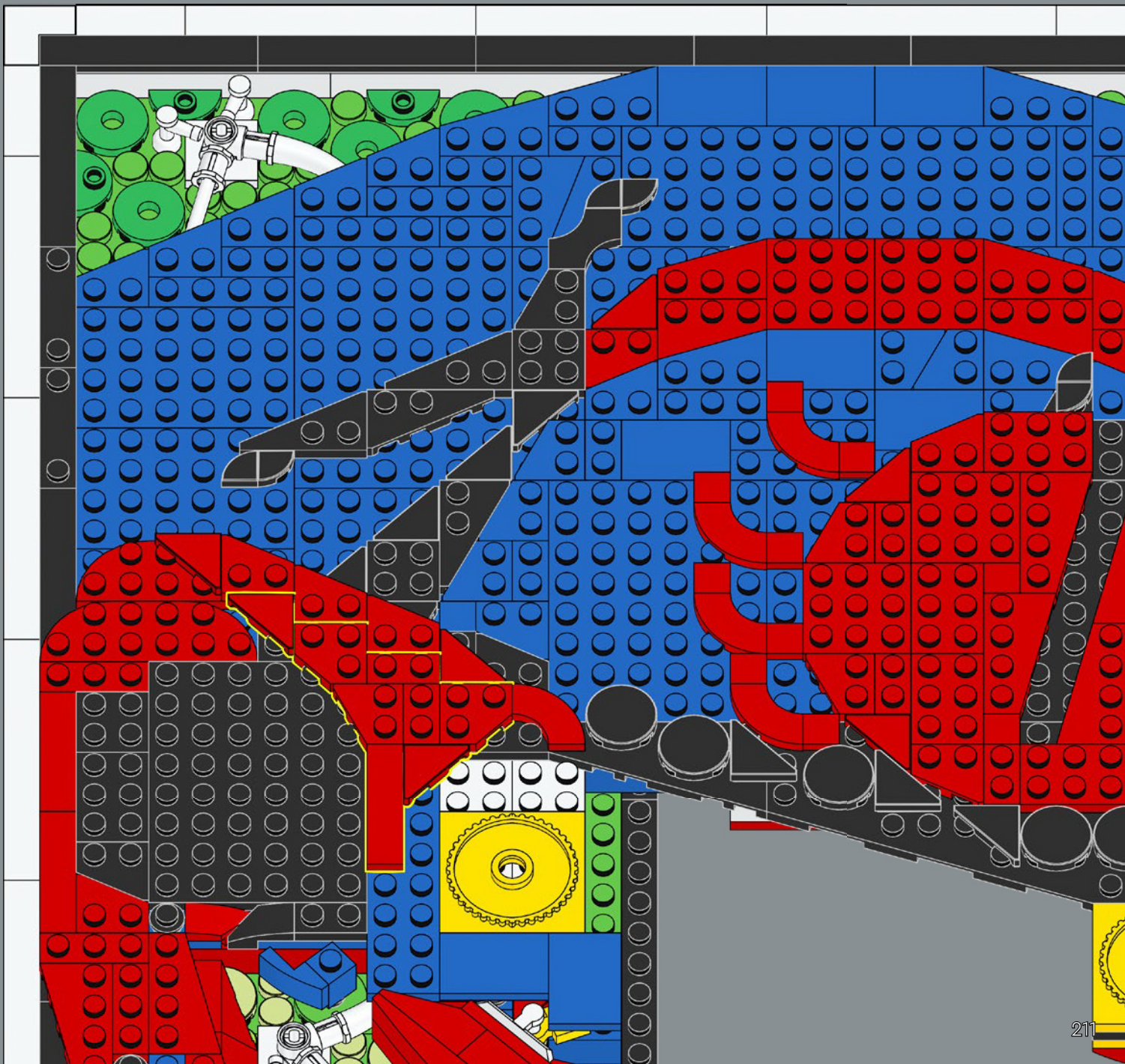



241

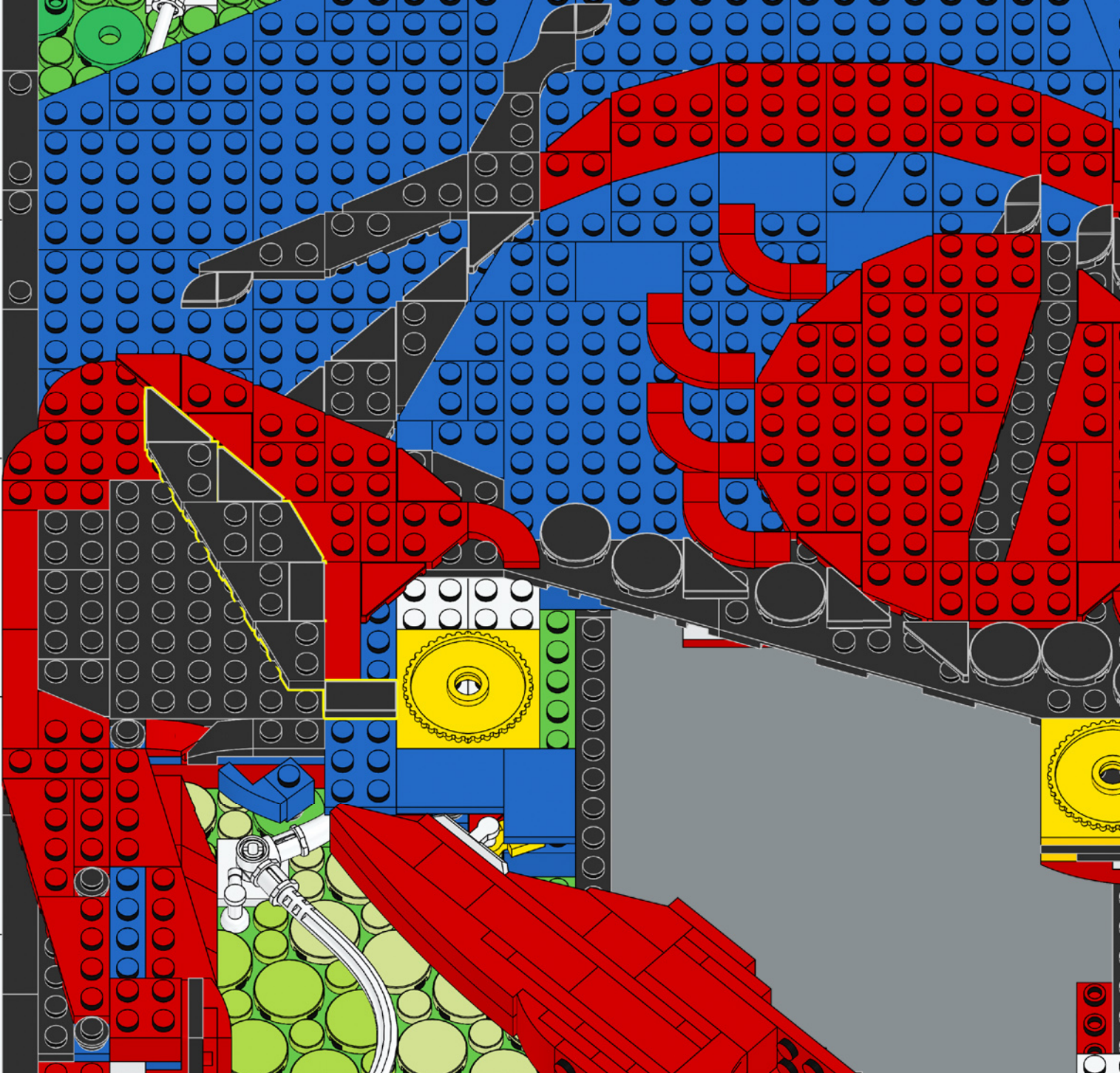

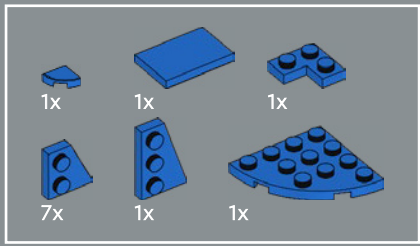

242

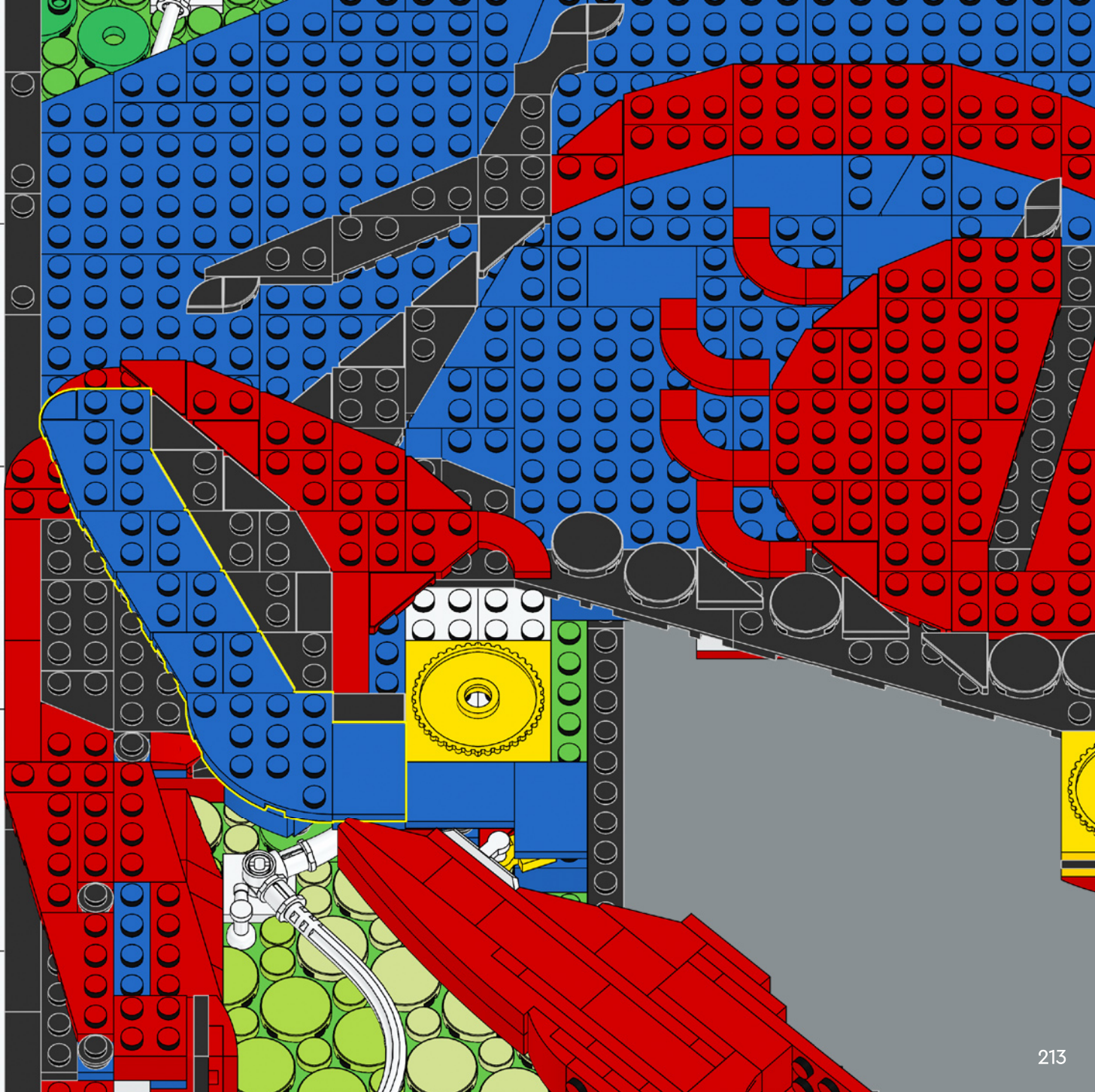

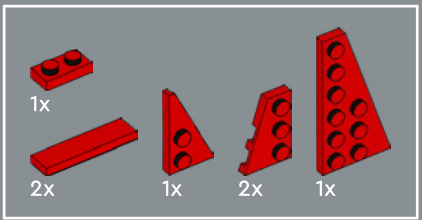

243

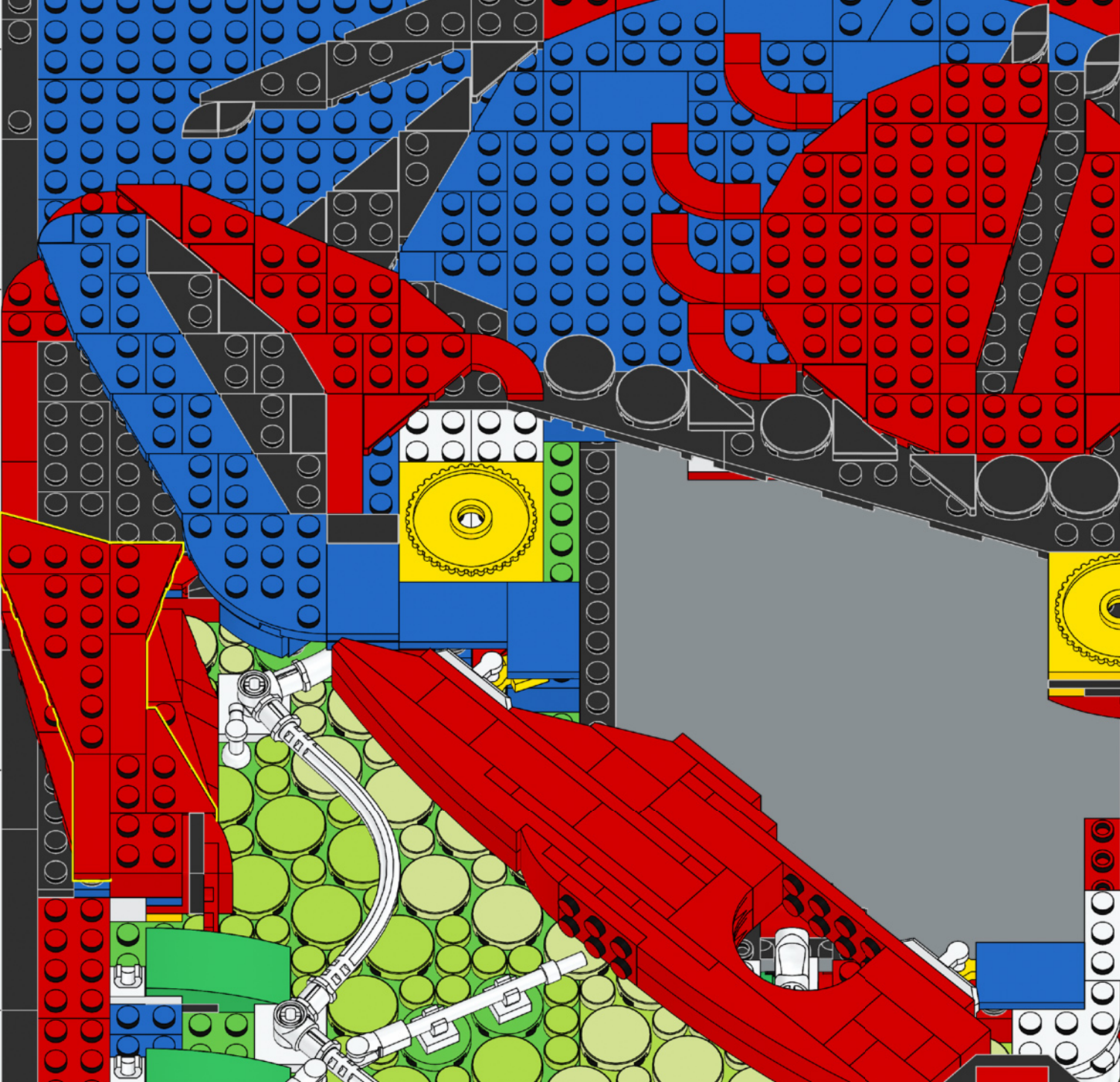

8x

244

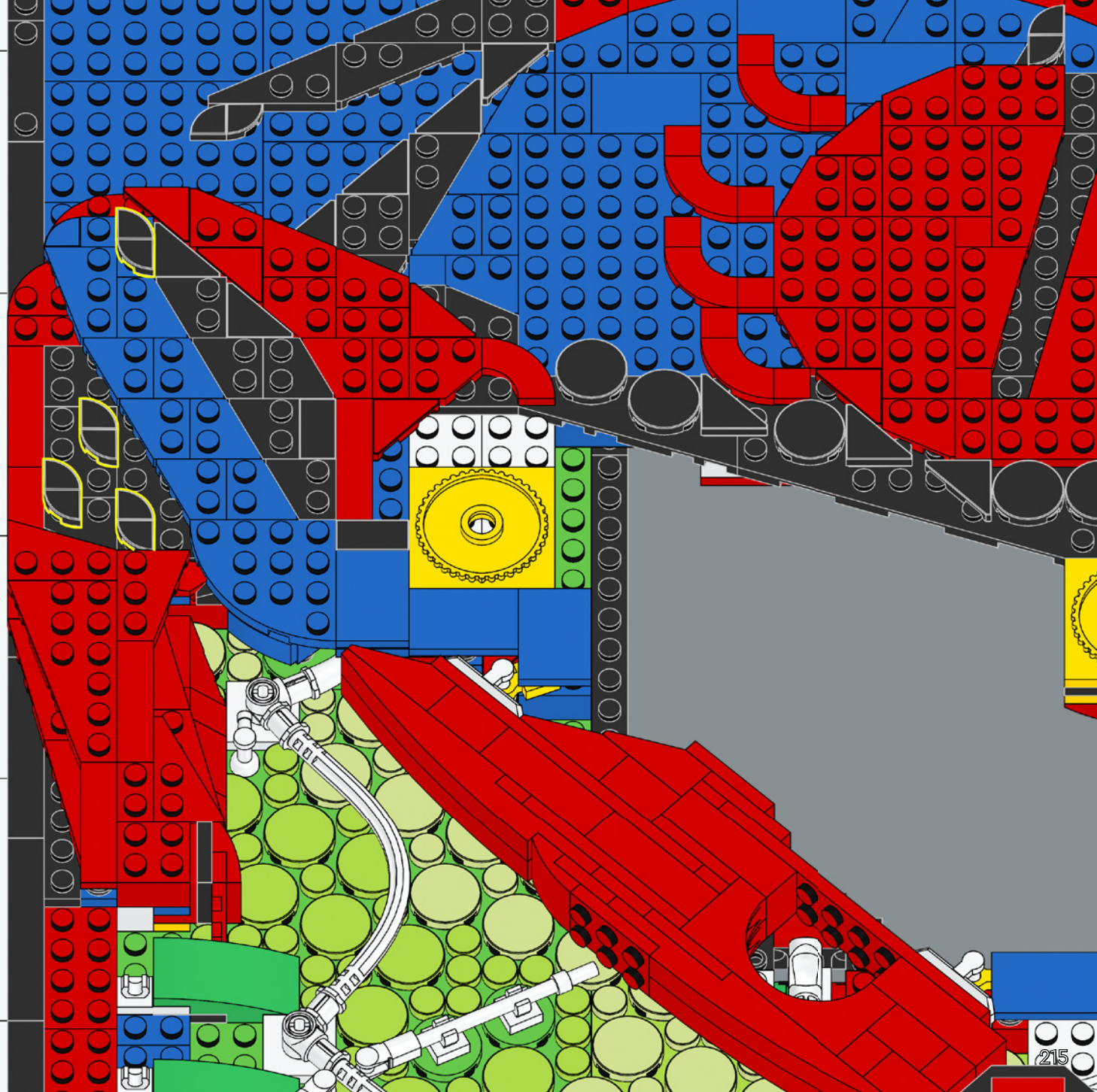

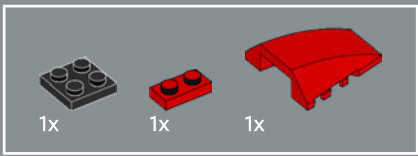

245

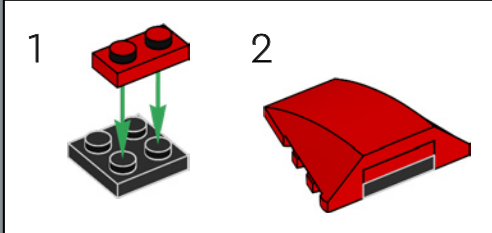



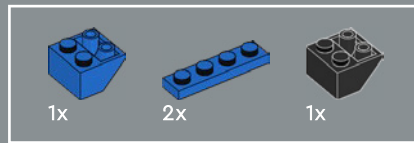

247

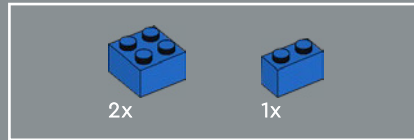
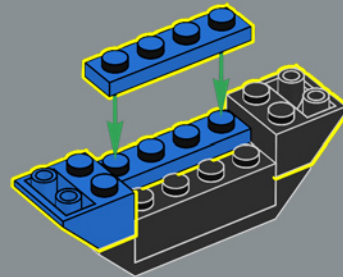

248

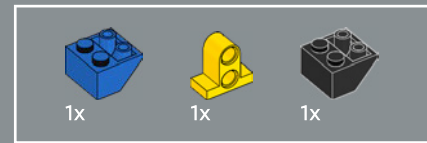
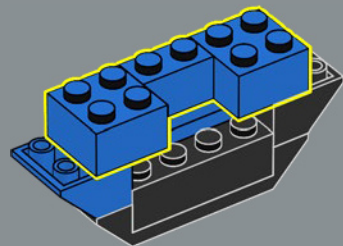

249

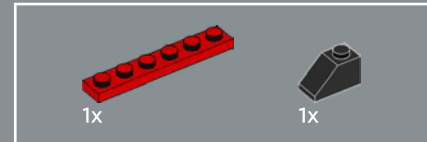
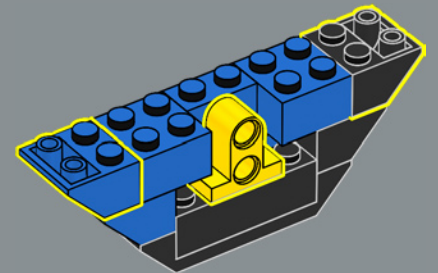

250

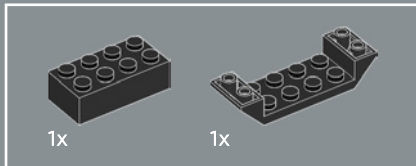
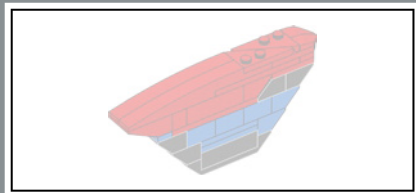
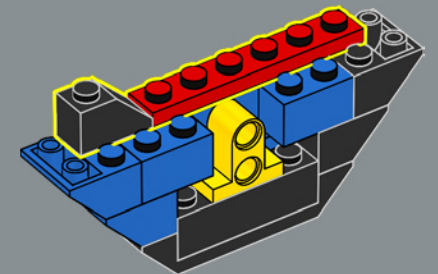

246

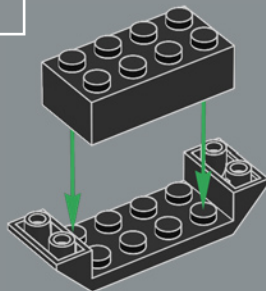

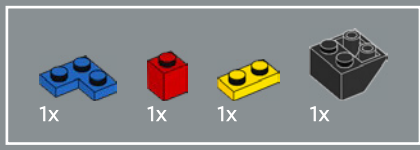

251

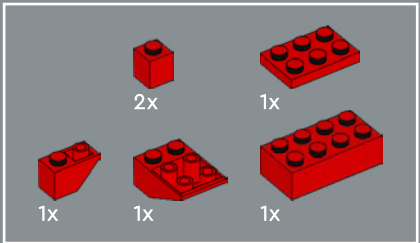
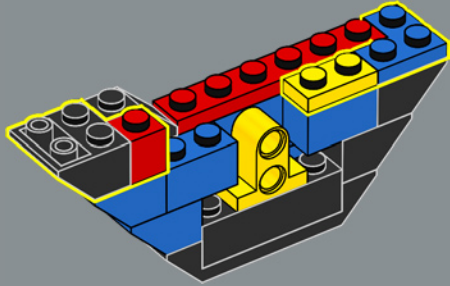

252

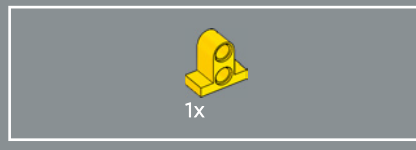
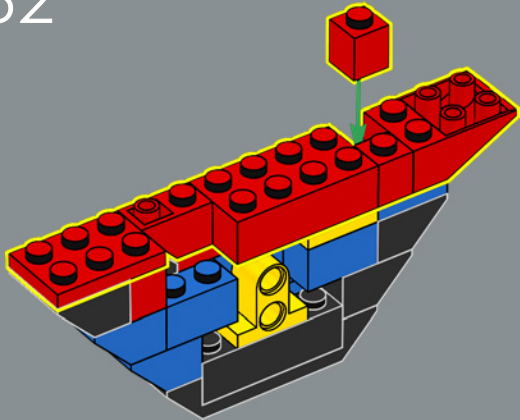

253

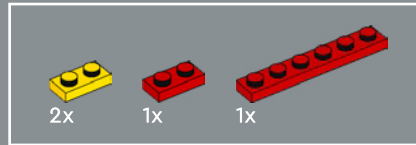
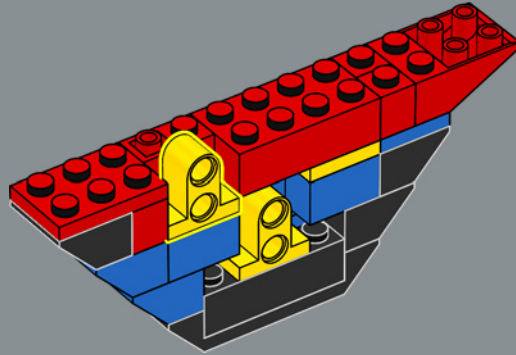

254

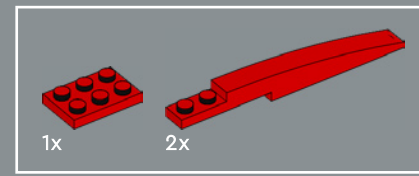
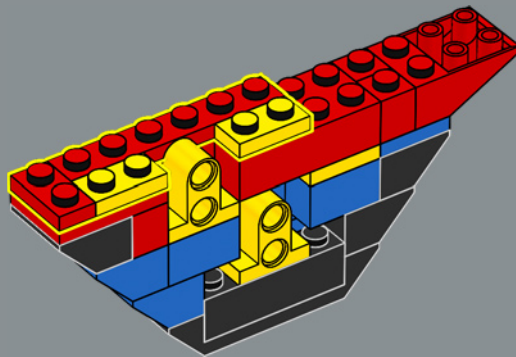

255

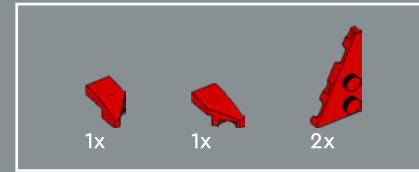
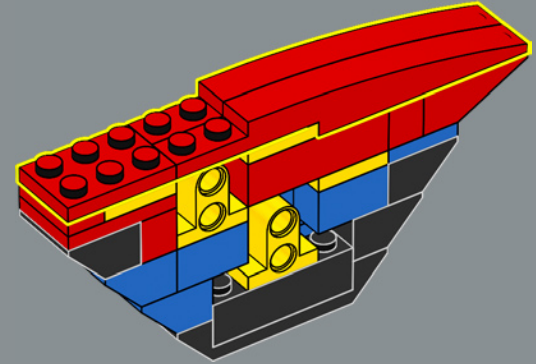

256

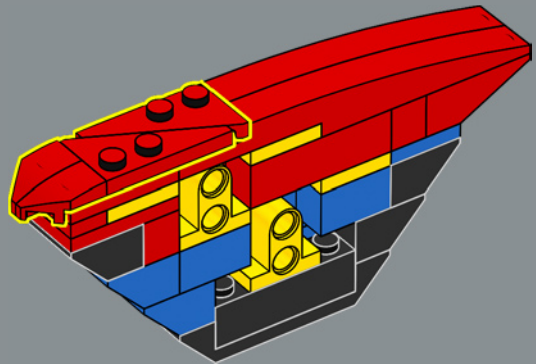

257

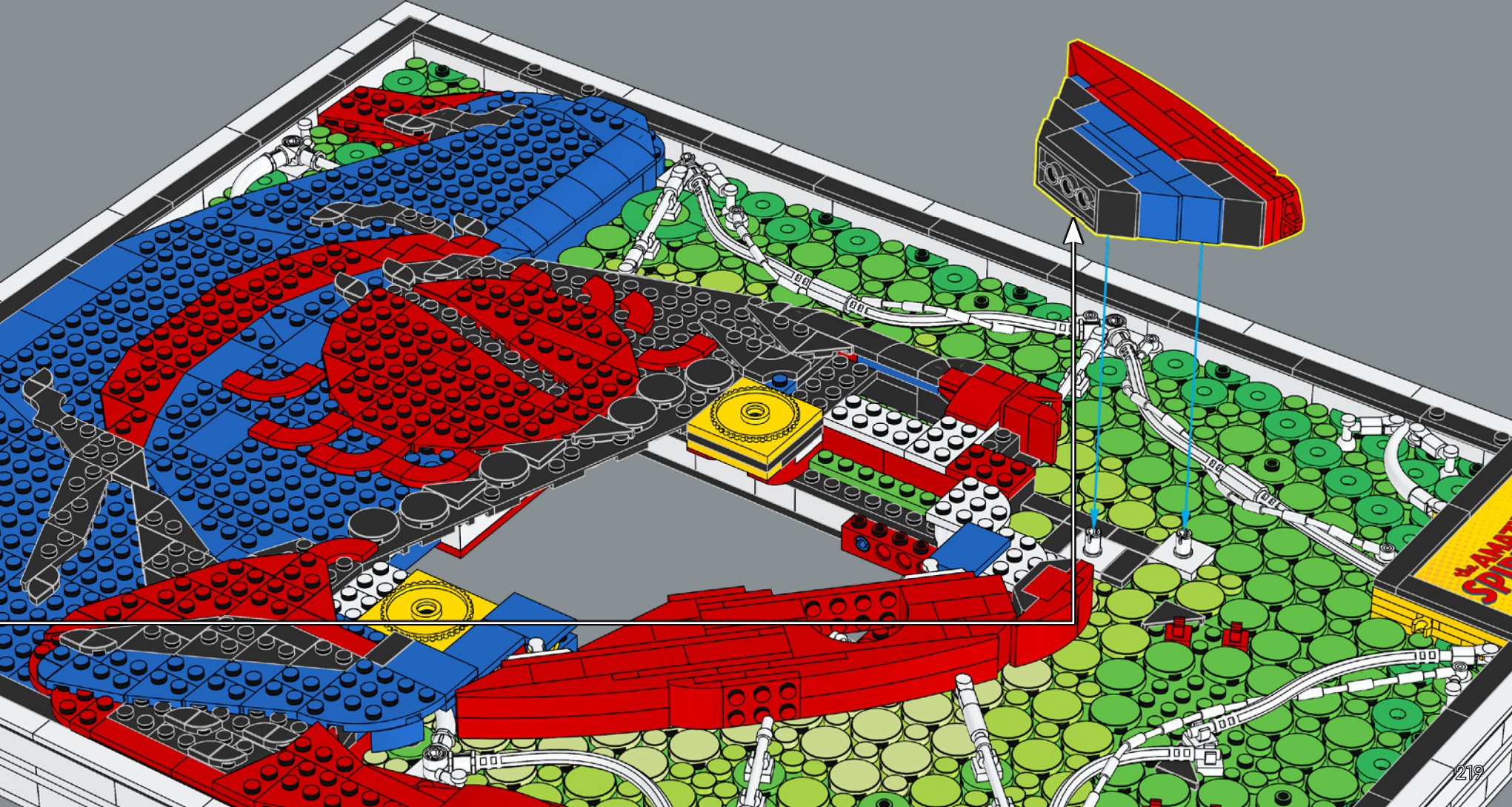
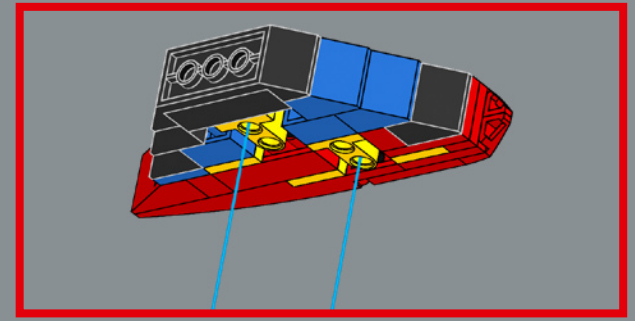



258

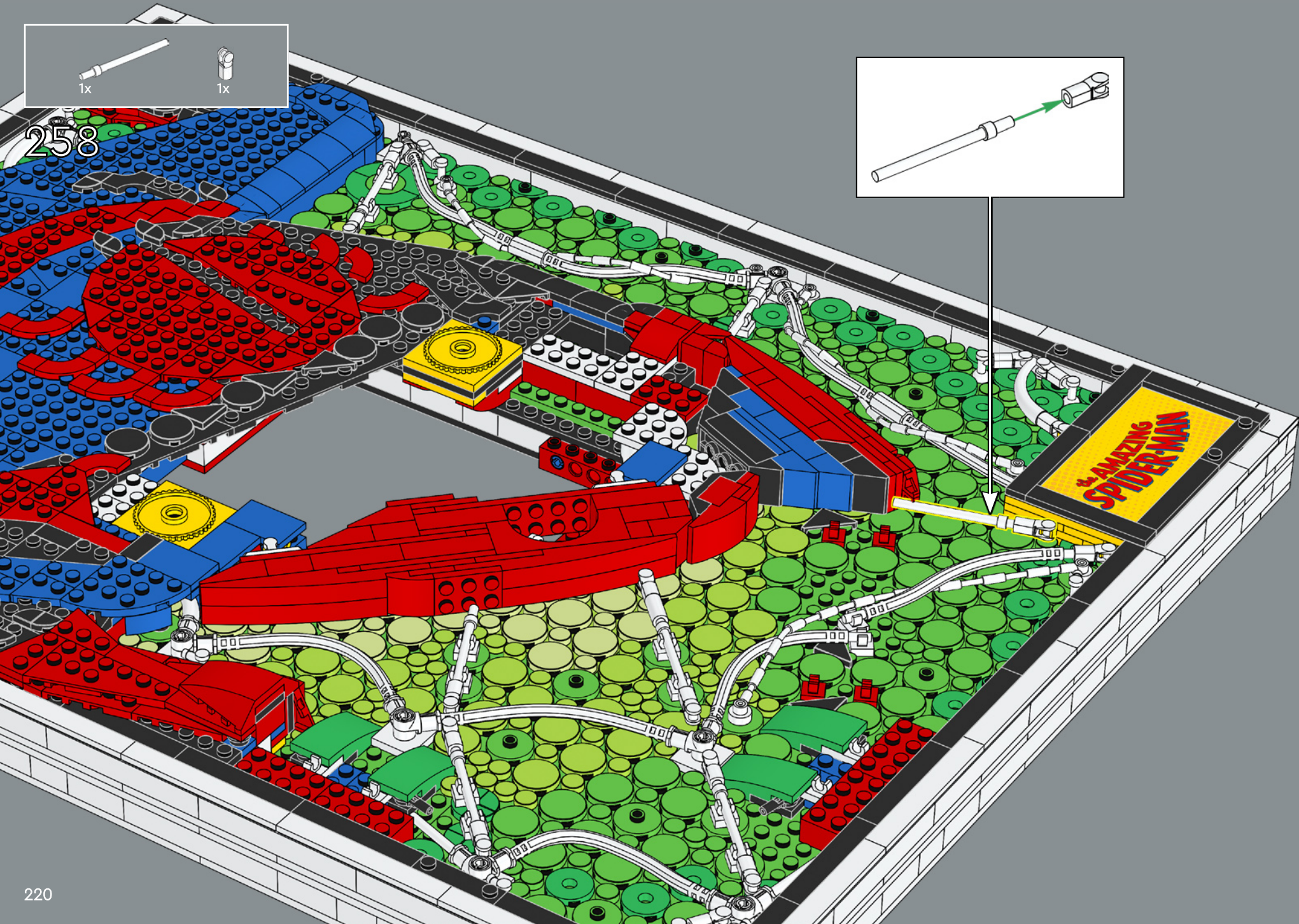
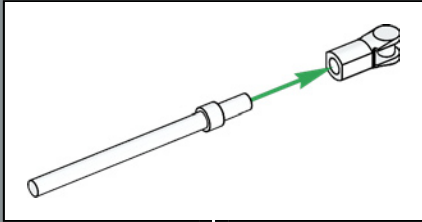

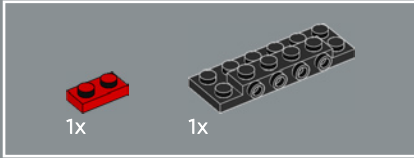
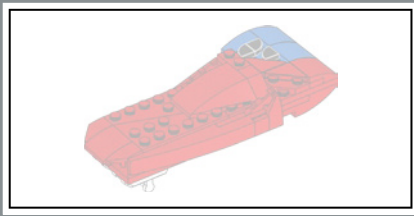

259

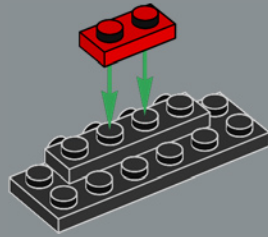

260

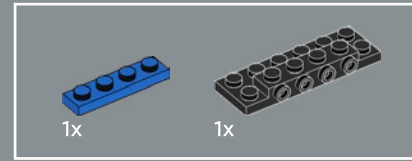
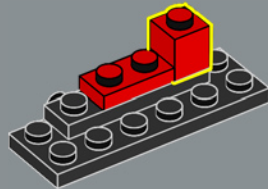

261

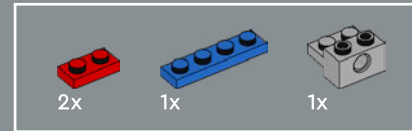
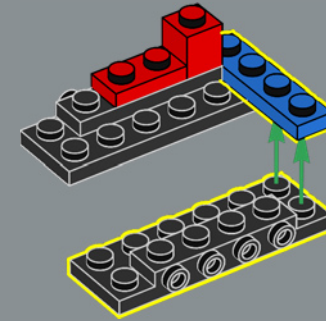

262

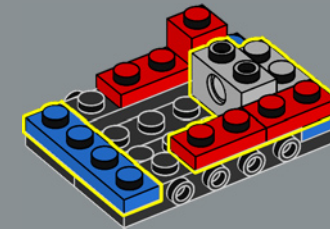

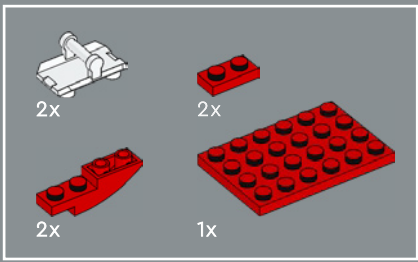

263

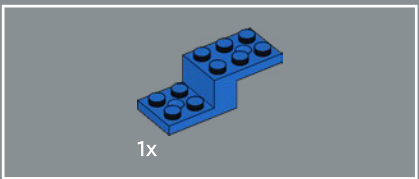
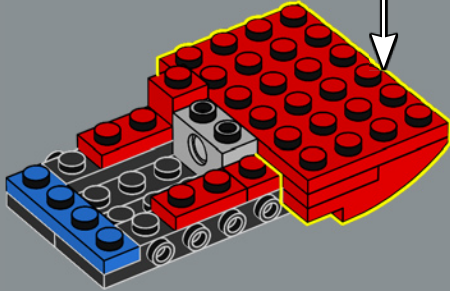
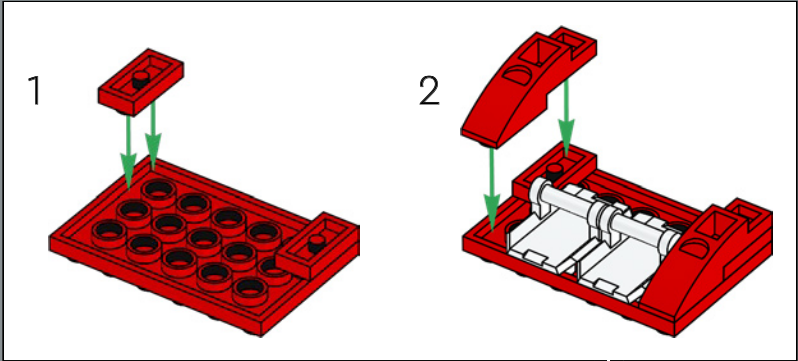

264

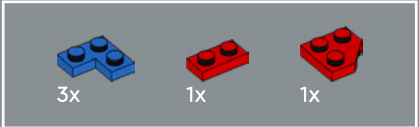
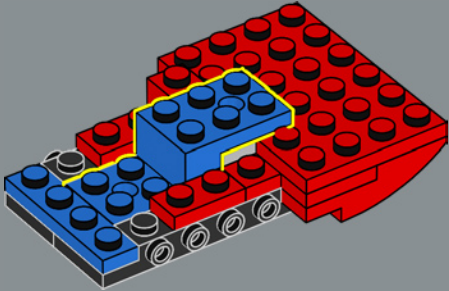

265

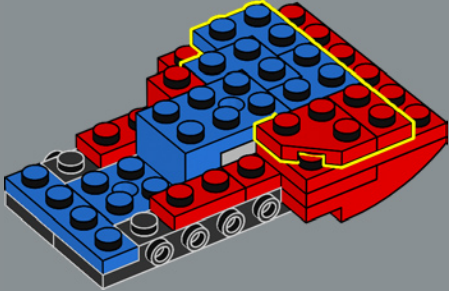

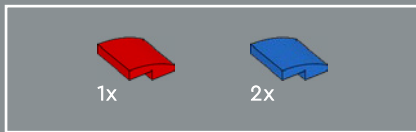

266

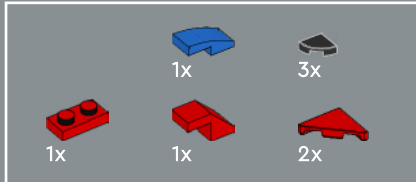
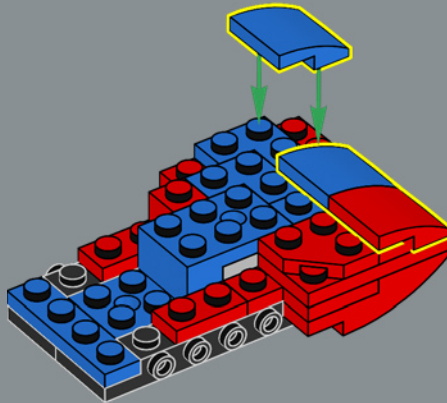

267

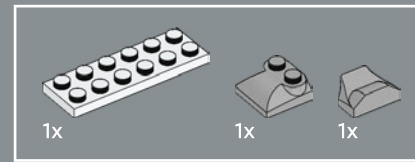
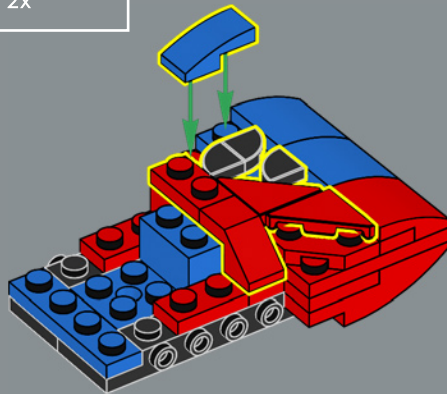

268

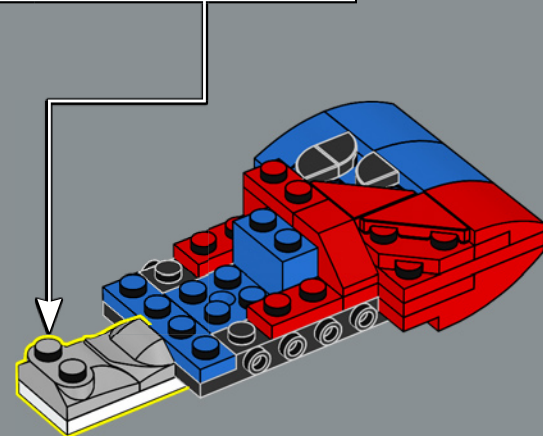
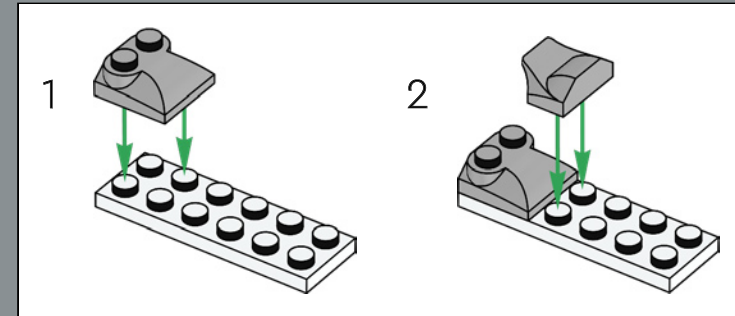

Did you know? Spider-Man wears web-shooters on his wrists beneath his costume – they can shoot thin strands of the special web fluid at high pressure.

Le savez-vous ? Spider-Man porte des lanceurs de toile sur ses poignets, sous son costume. Ils peuvent projeter de fines bandes de liquide spécial pour toile à haute pression.

¿Lo sabías? Spider-Man lleva lanzatarañas en las muñecas por debajo del traje que pueden lanzar finas hebras de líquido de telarañas especial a alta presión.

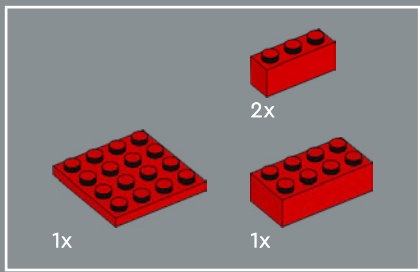

269

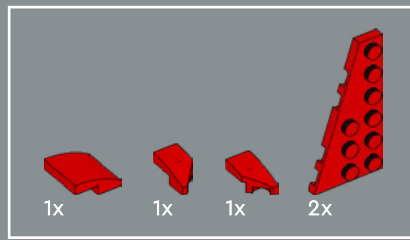
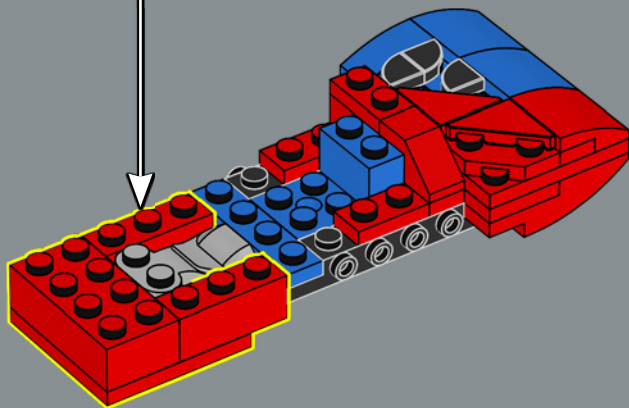
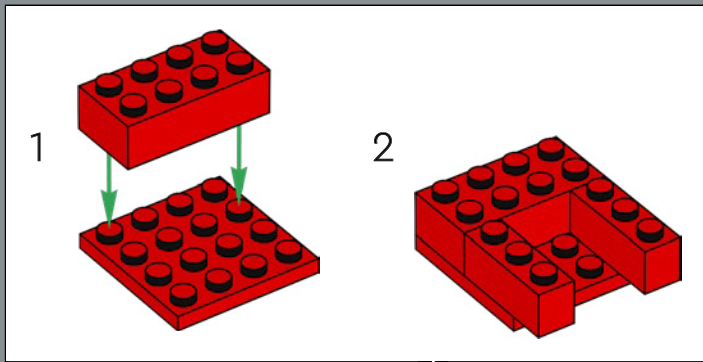

270

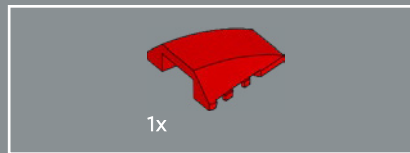
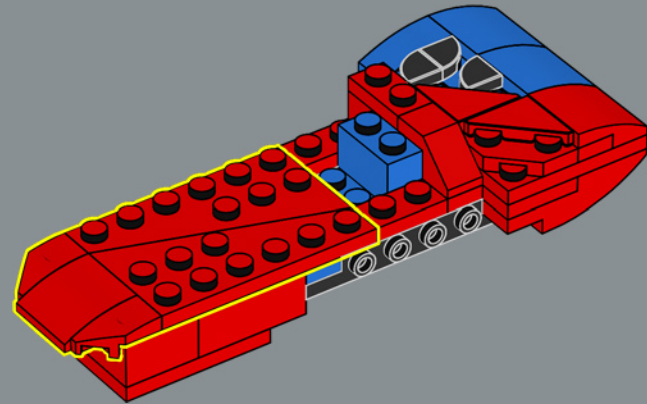

271

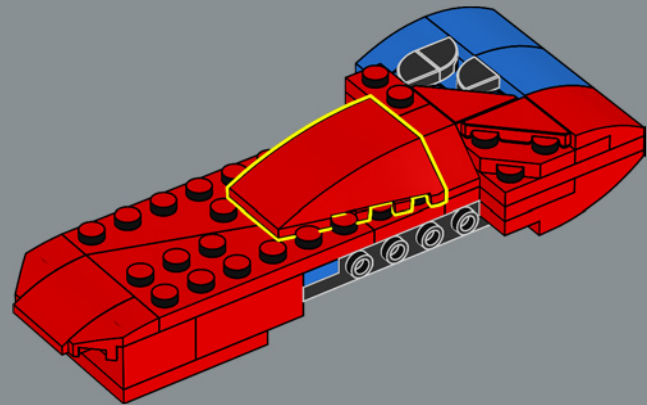



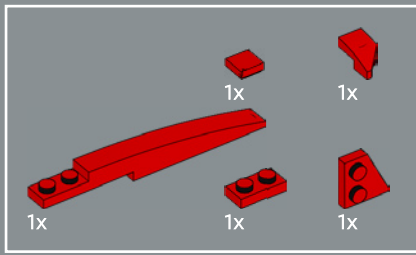

272

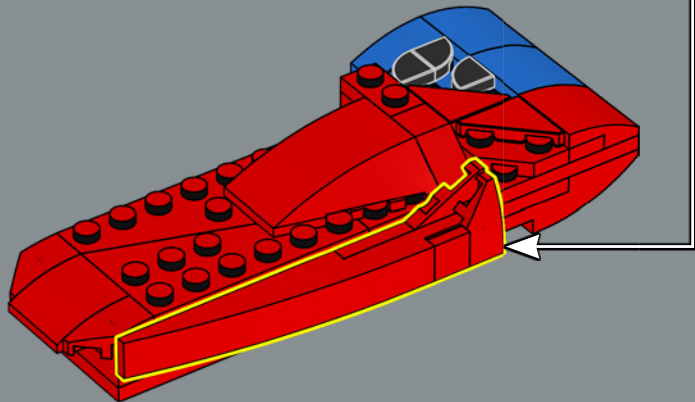
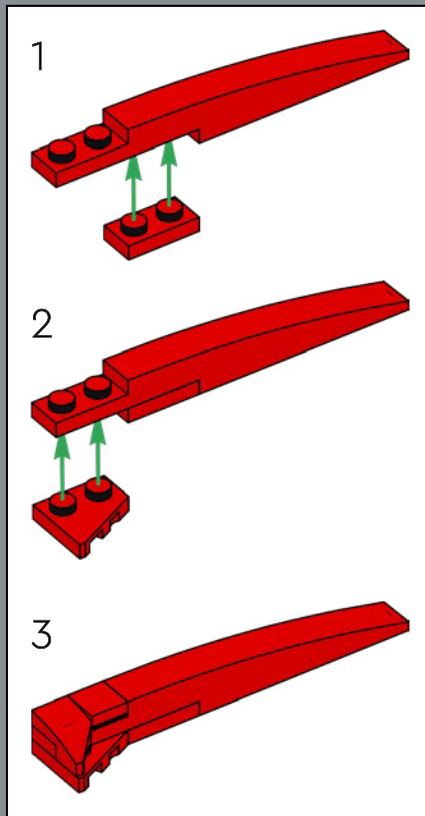

273

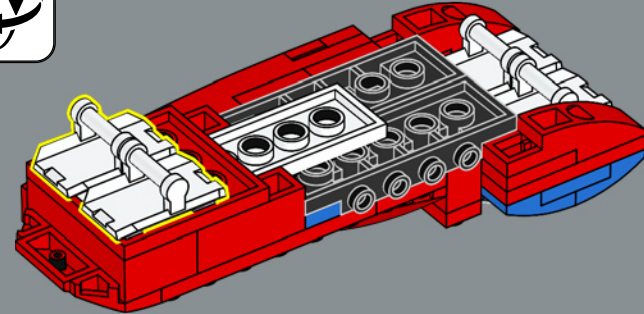

Pythagorean theorem tells us that  $A^2 + B^2 = C^2$ , meaning that  $11^2 + 2^2 = C^2$  and  $C = \sqrt{125}$

Le théorème de Pythagore nous dit que  $A^2 + B^2 = C^2$ , ce qui signifie que  $11^2 + 2^2 = C^2$  et  $C = \sqrt{125}$ .

El teorema de Pitágoras nos dice que  $A^2 + B^2 = C^2$ , lo que significa que  $11^2 + 2^2 = C^2$  y que  $C = \sqrt{125}$ .

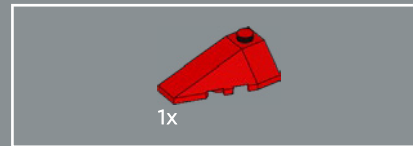

274

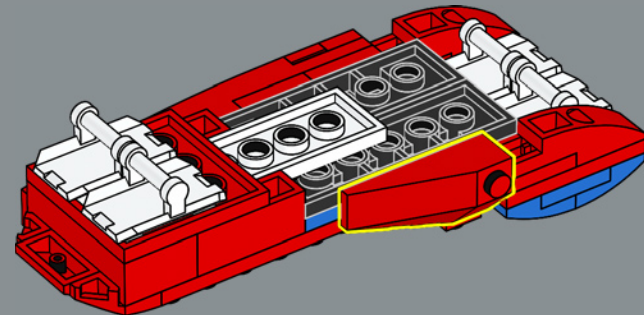

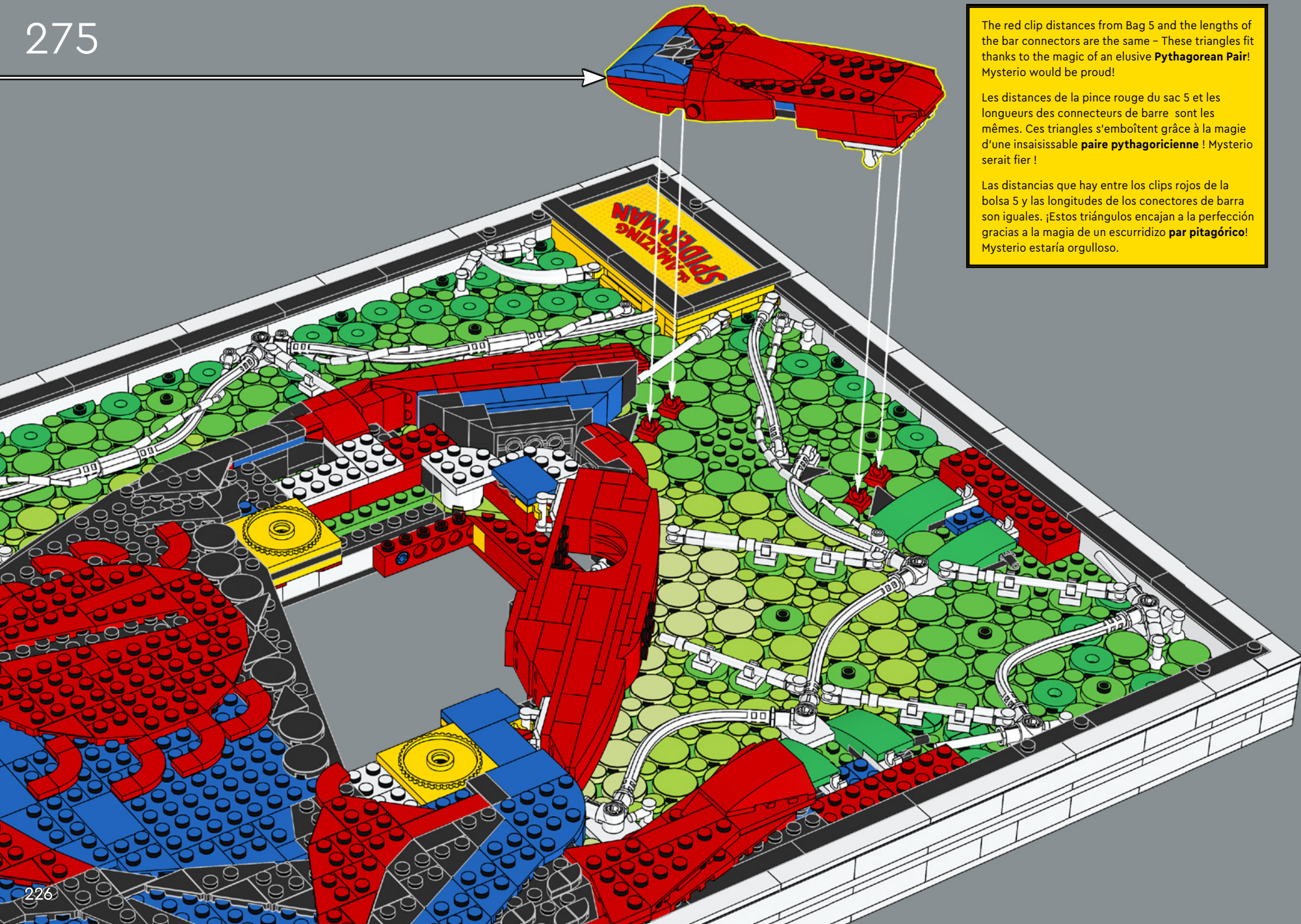

The red clip distances from Bag 5 and the lengths of the bar connectors are the same – These triangles fit thanks to the magic of an elusive **Pythagorean Pair!** Mysterio would be proud!

Les distances de la pince rouge du sac 5 et les longueurs des connecteurs de barre sont les mêmes. Ces triangles s'emboîtent grâce à la magie d'une insaisissable **paire pythagoricienne!** Mysterio serait fier !

Las distancias que hay entre los clips rojos de la bolsa 5 y las longitudes de los conectores de barra son iguales. ¡Estos triángulos encajan a la perfección gracias a la magia de un escurridizo **par pitagórico!** Mysterio estaría orgulloso.

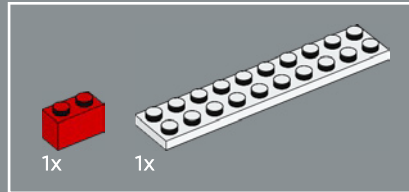
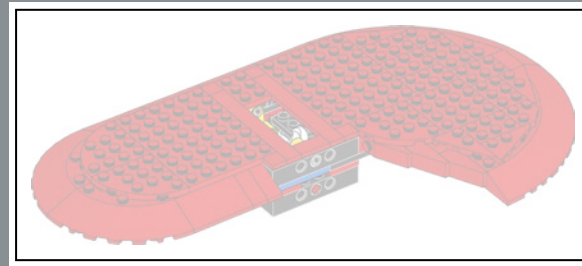
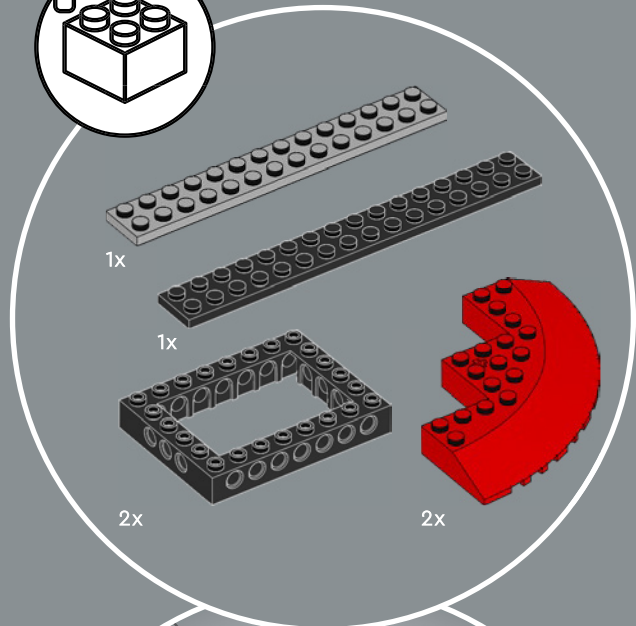
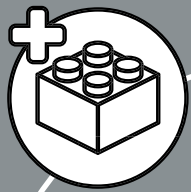

276

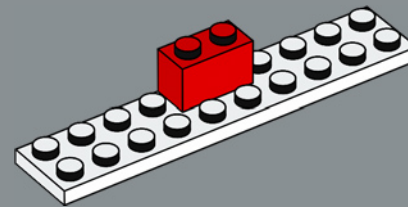

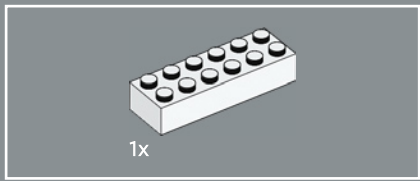

277

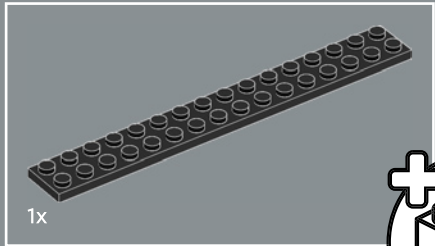
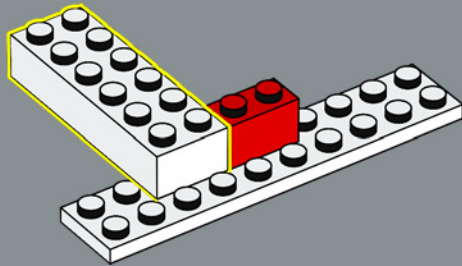

278

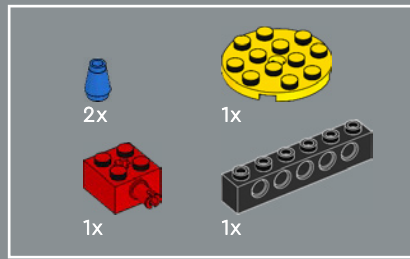
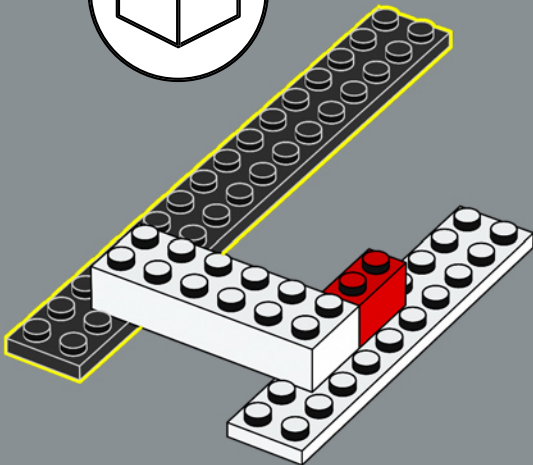
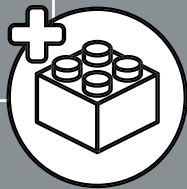

279

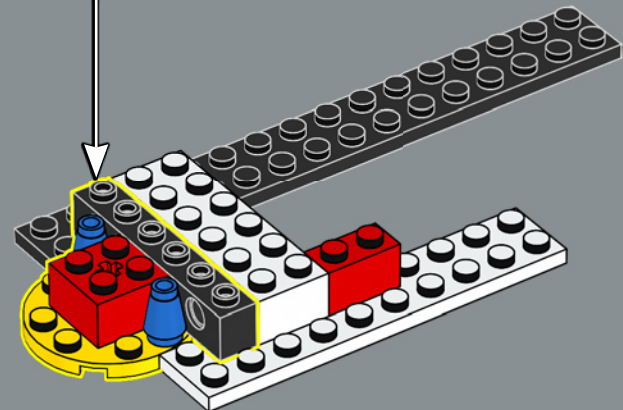
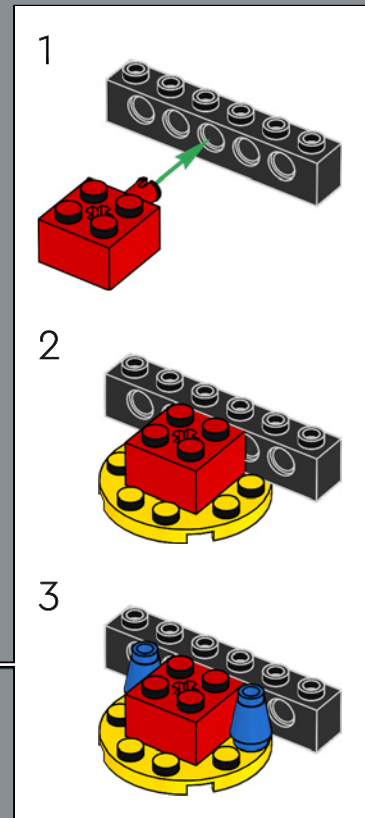

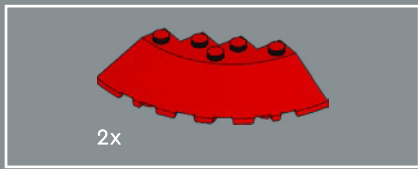

280

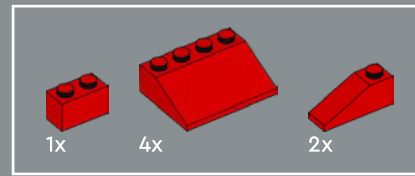
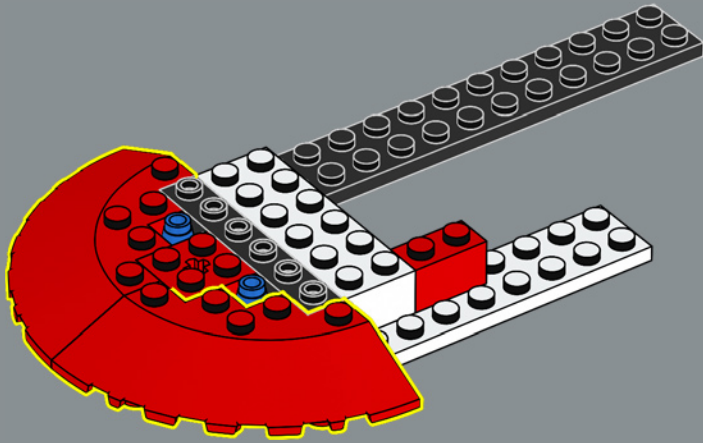

281

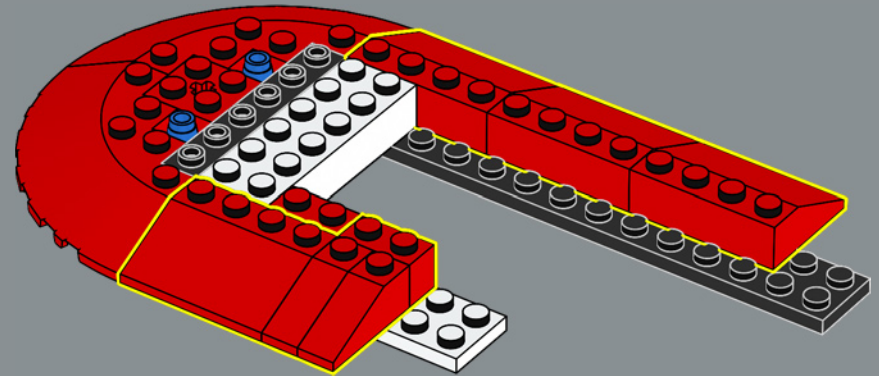

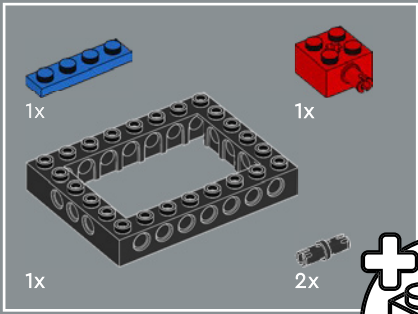

282

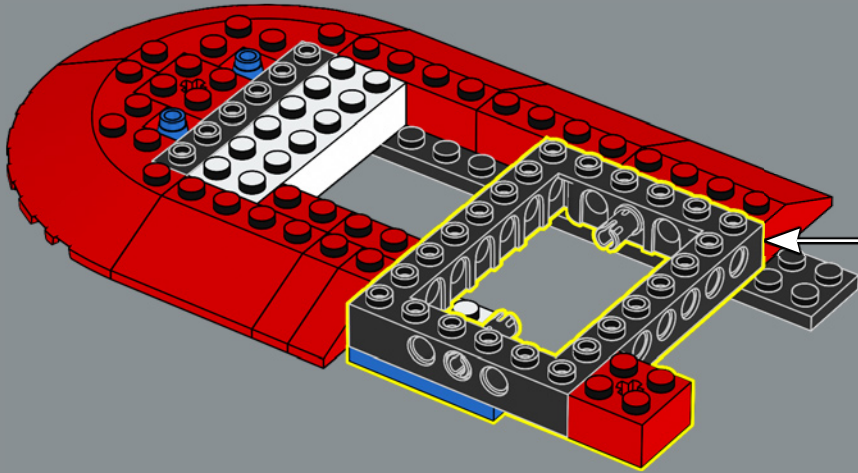
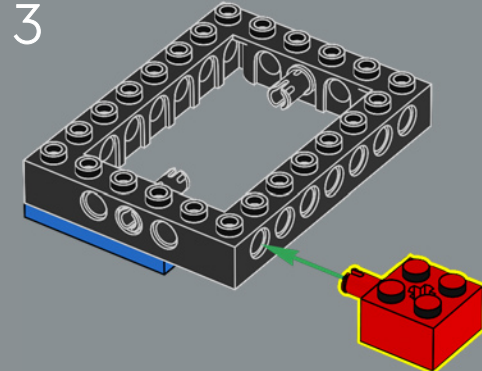
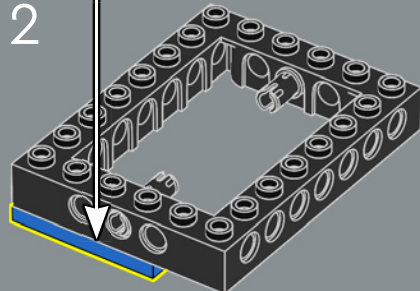
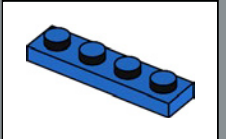
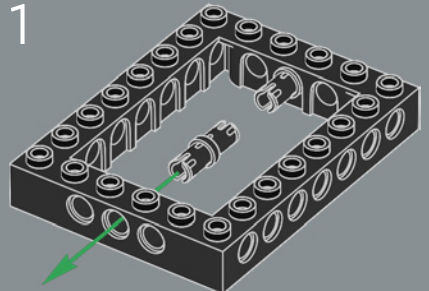

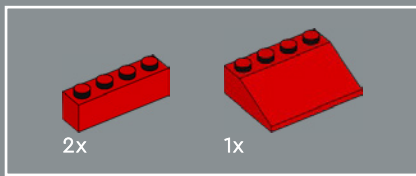

283

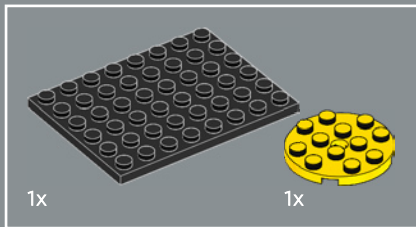
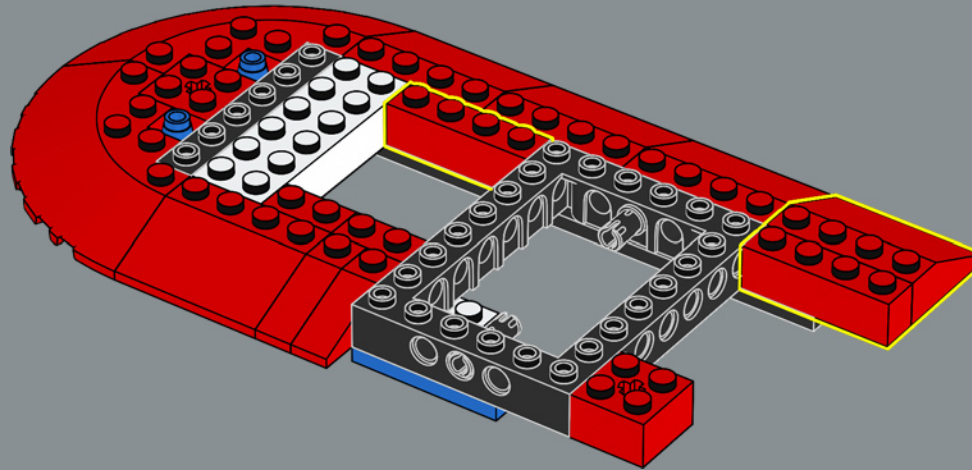

284

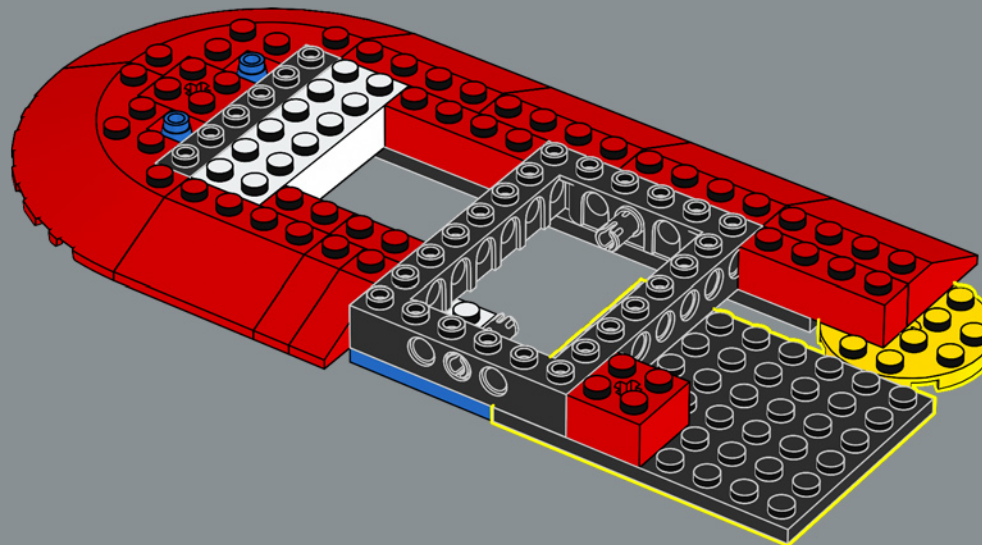

The yellow 4x4 round plates are also placed precisely **18 across** and **3 down** ... Correct guesses as to the purpose might be awarded a prestigious No-Prize.

Les plaques rondes jaunes 4x4 sont également placées précisément **18 en largeur et 3 en profondeur**... Les devinettes correctes quant à l'objectif pourraient être récompensées par un prestigieux No-Prize.

Las placas redondas amarillas 4x4 también se colocan exactamente en cantidades de **18 a lo ancho y 3 a lo alto**... A quien adivine el propósito de ello se le podría otorgar el prestigioso galardón No-Prize.

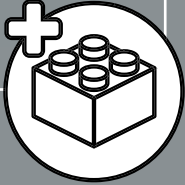
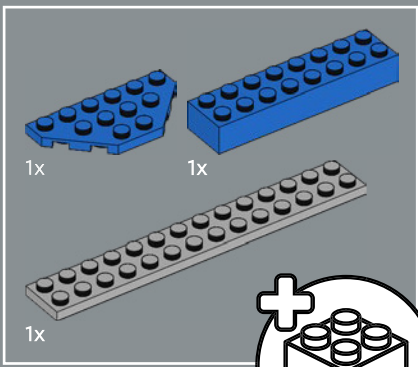

285

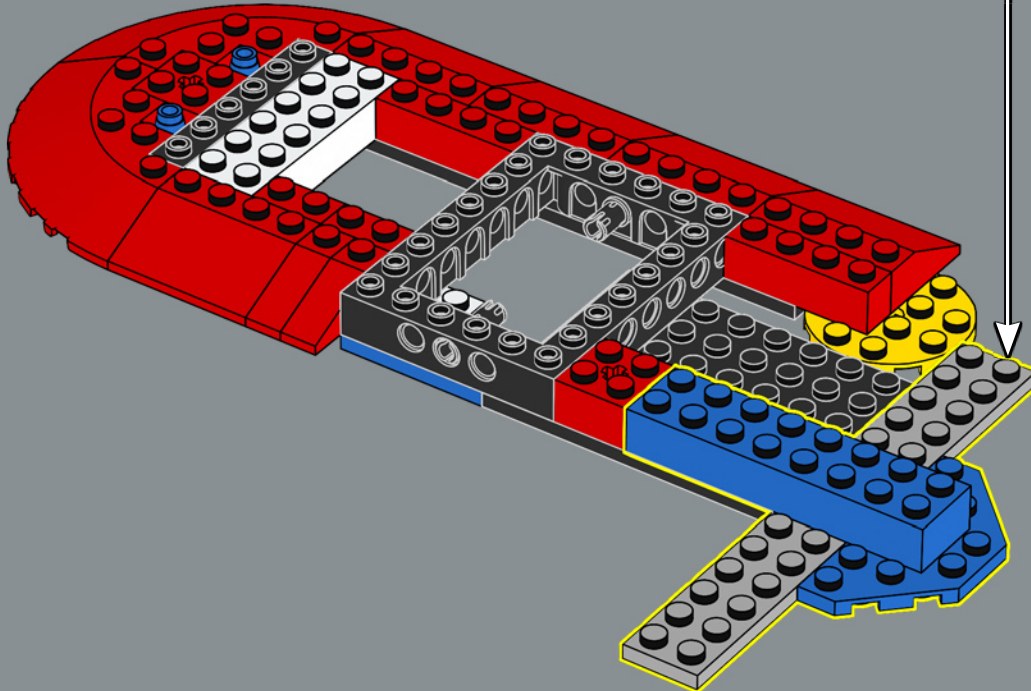
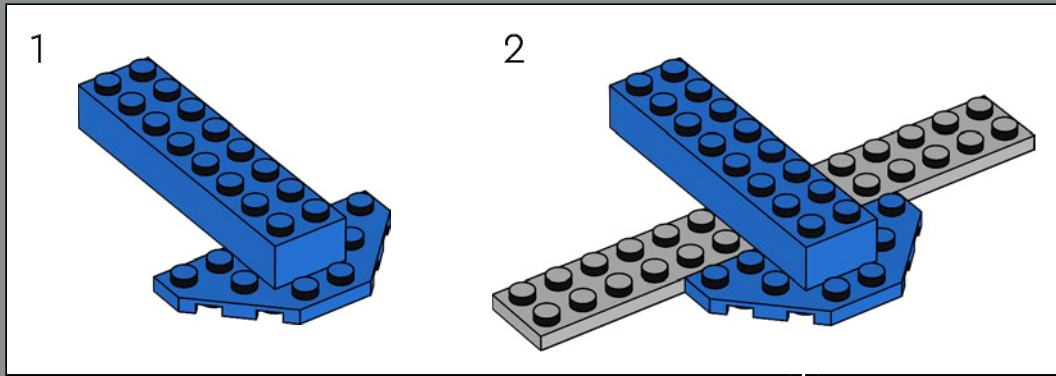



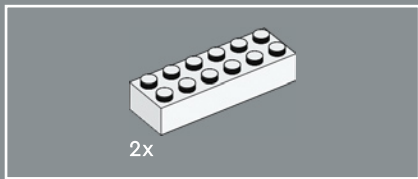

286

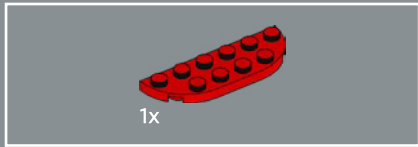
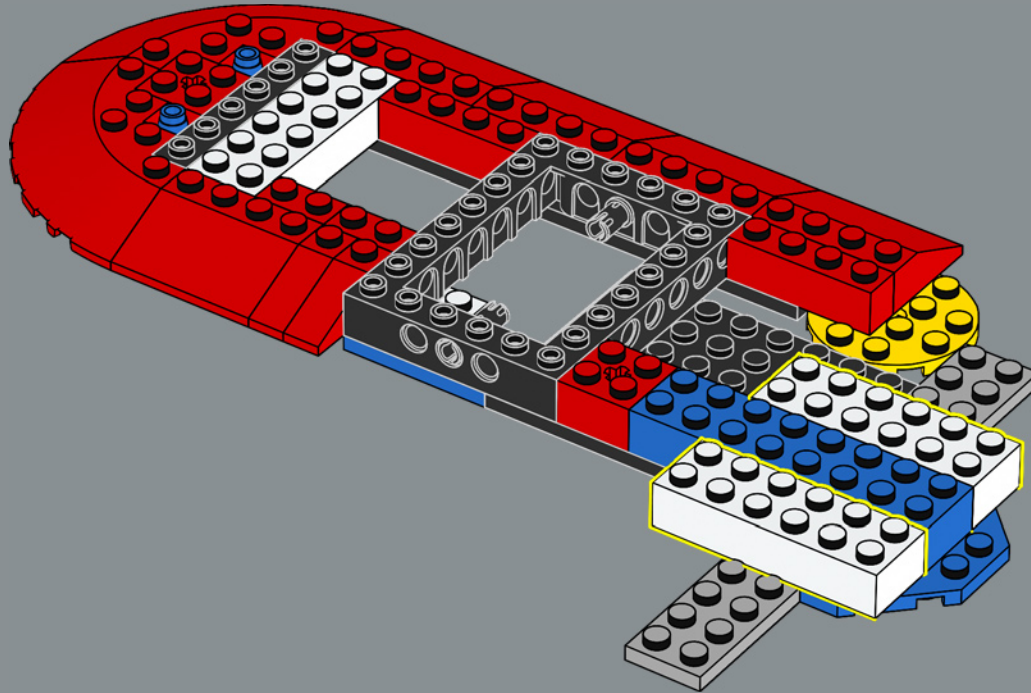

287

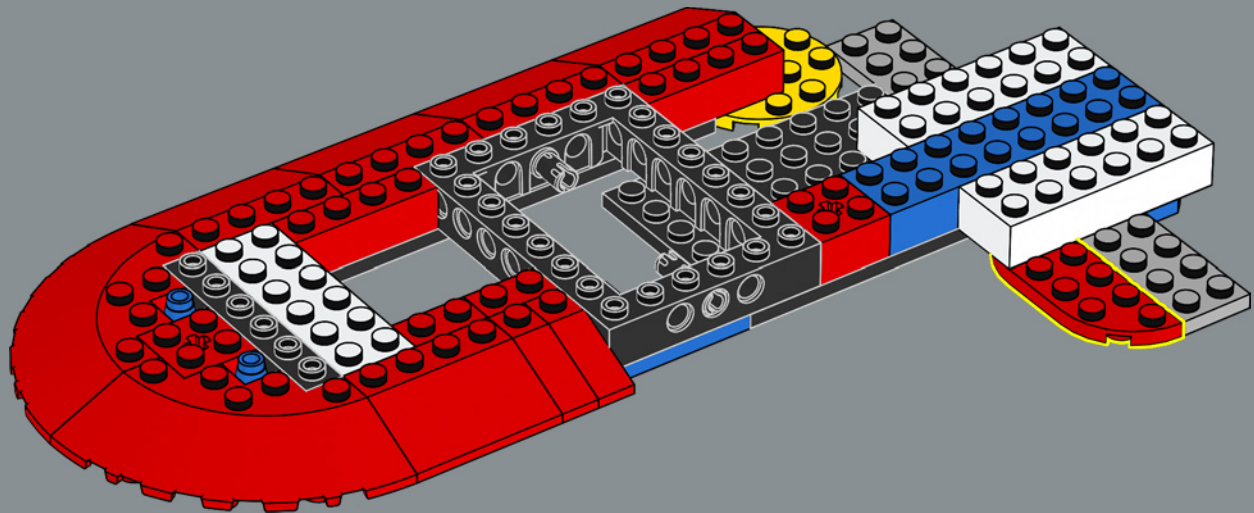

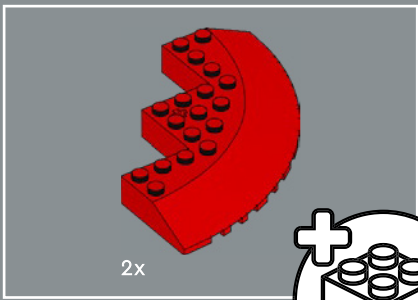

2x

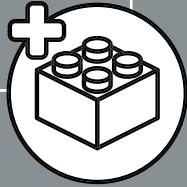

288

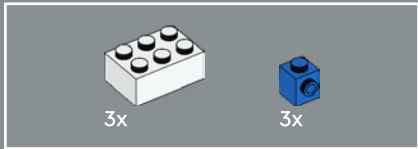
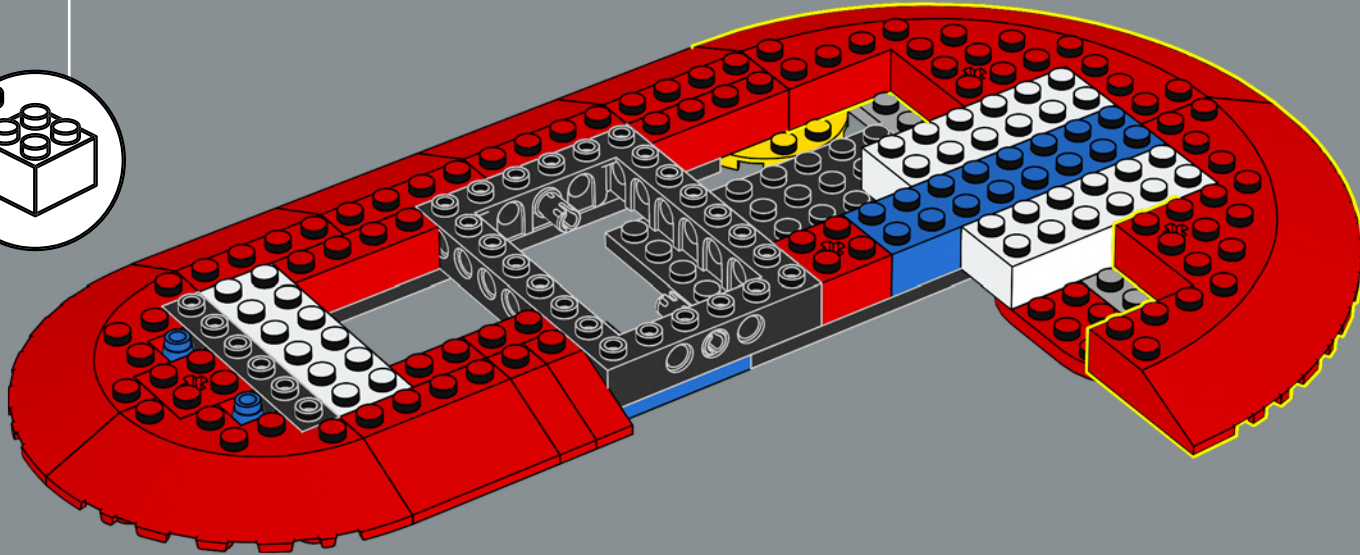

3x

3x

289

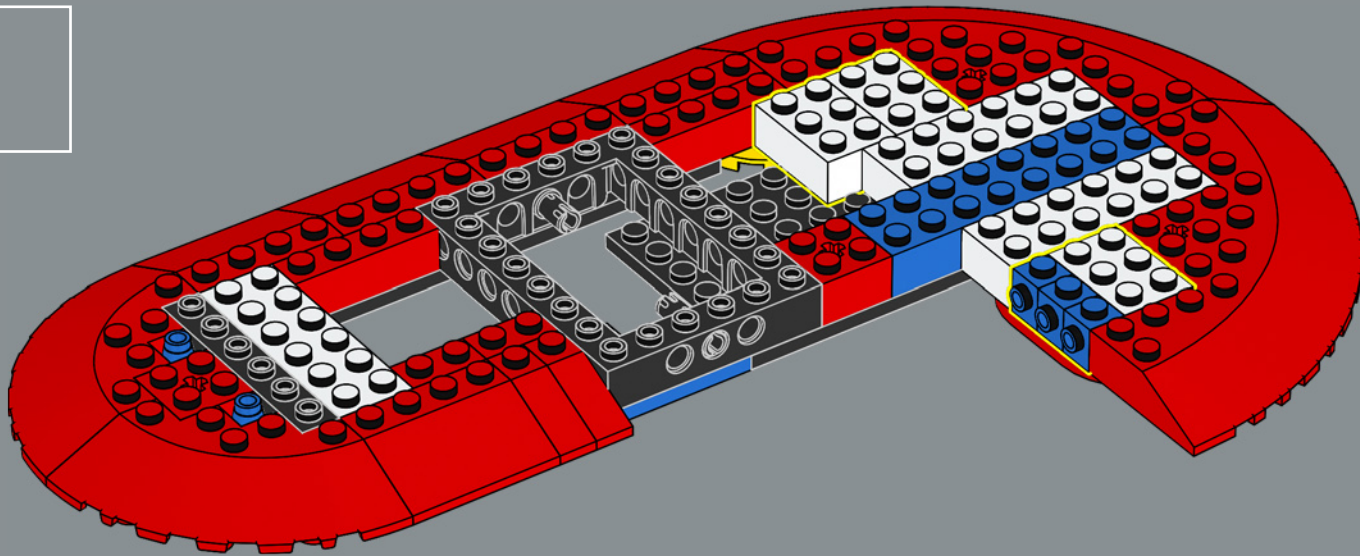

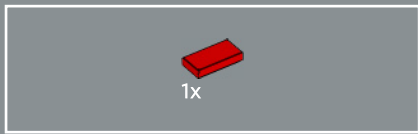

290

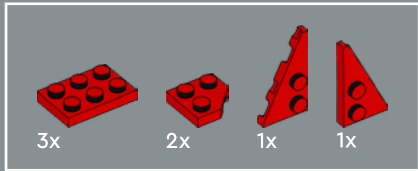
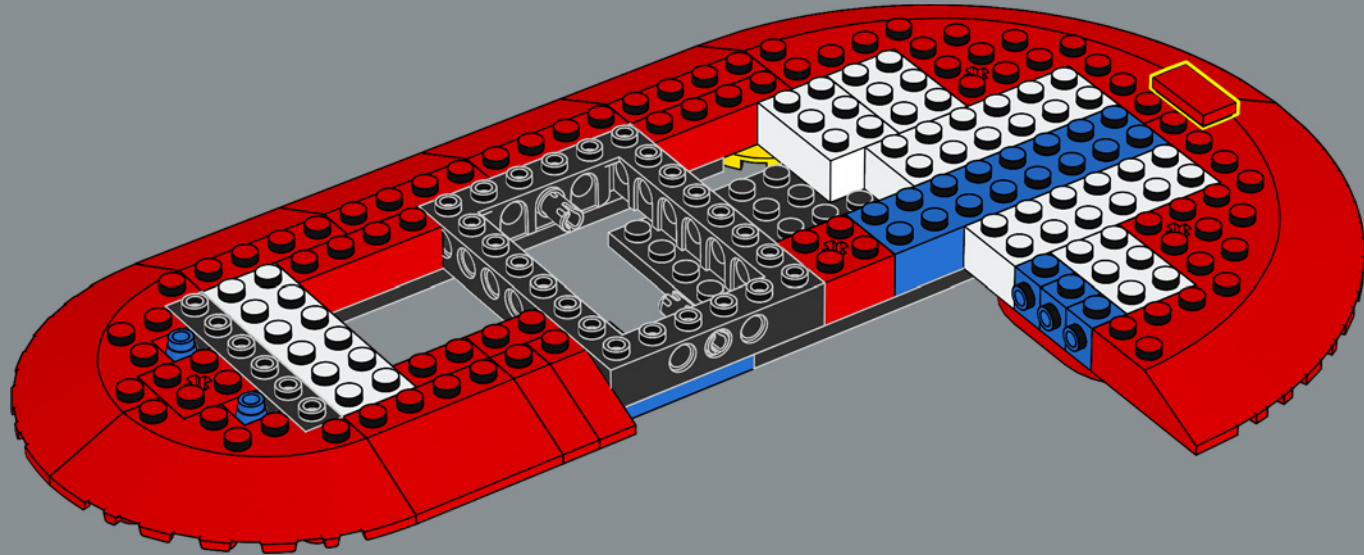

291

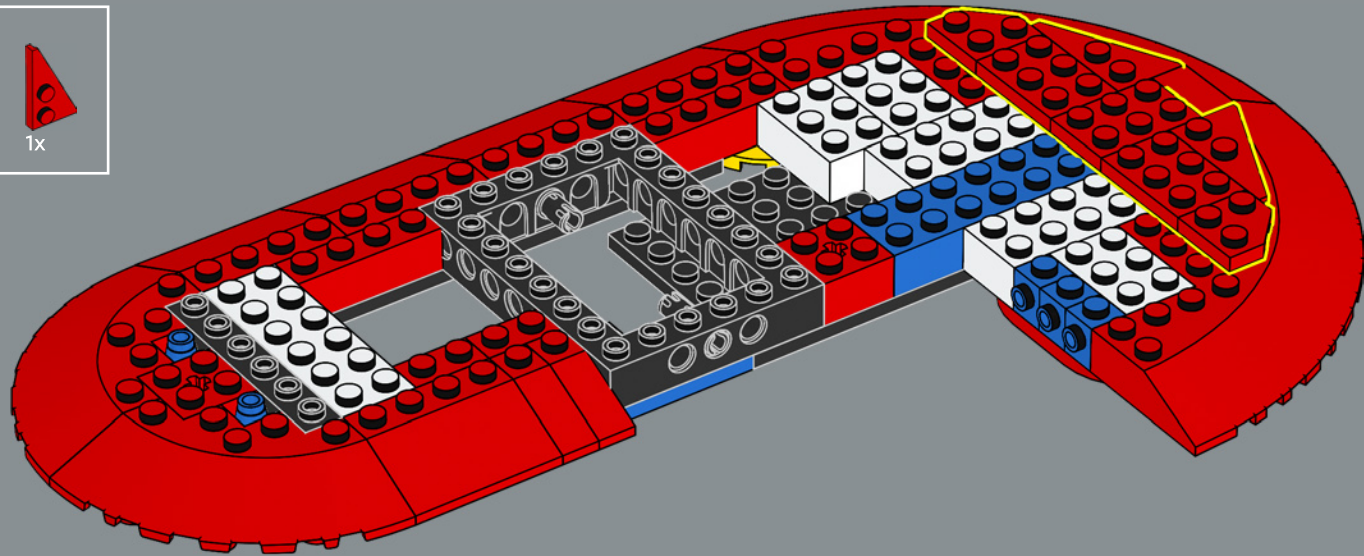

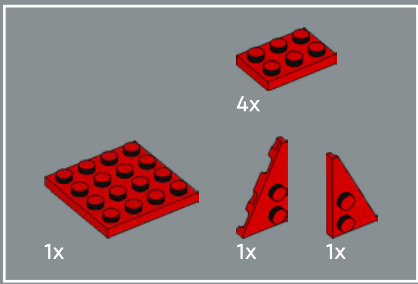

292

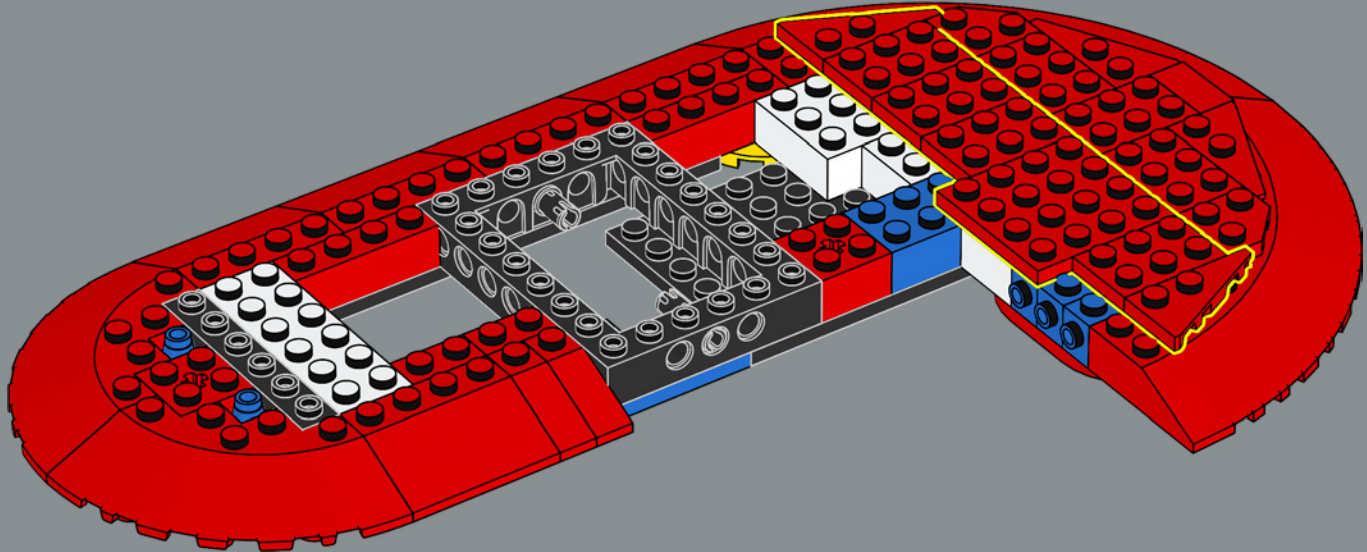

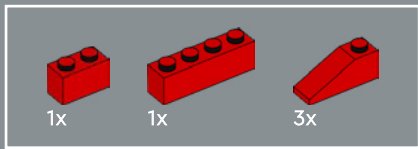

293

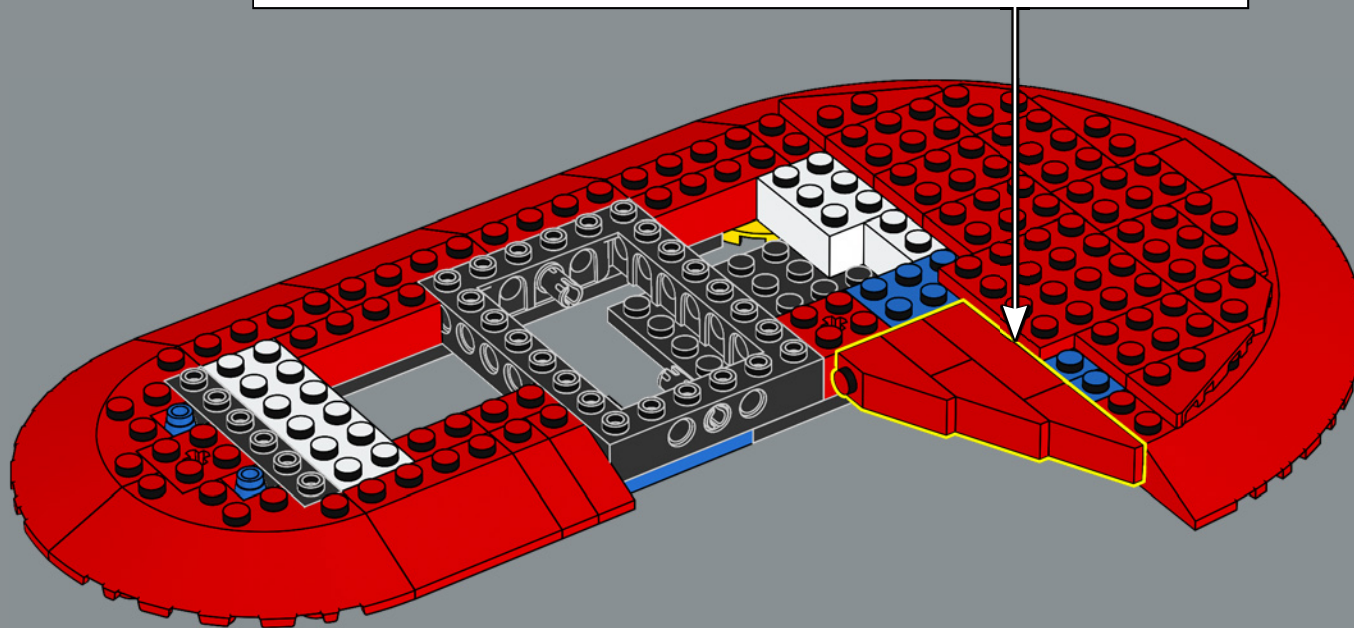
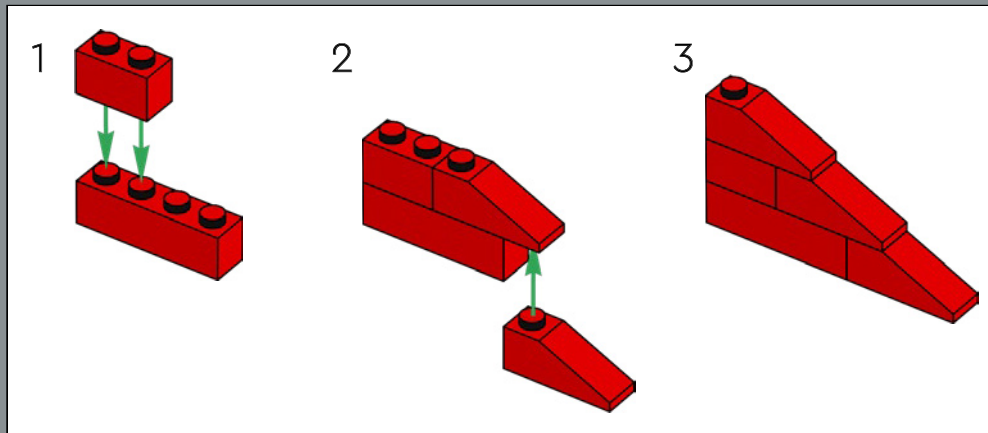

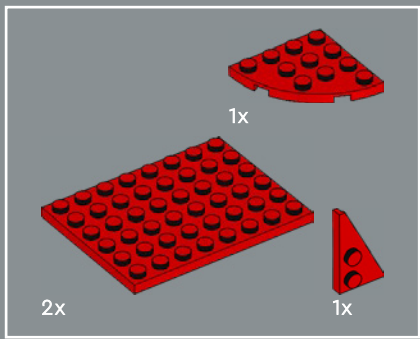

294

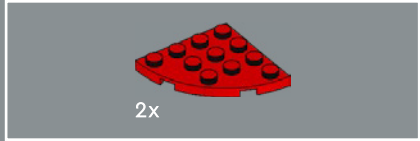
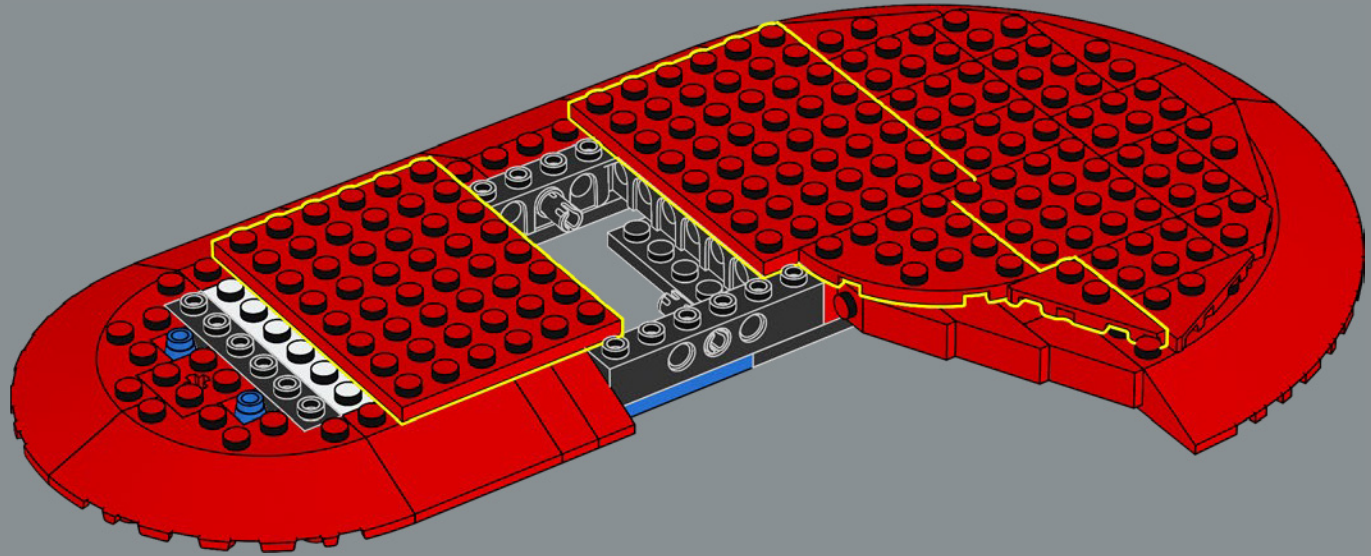

295

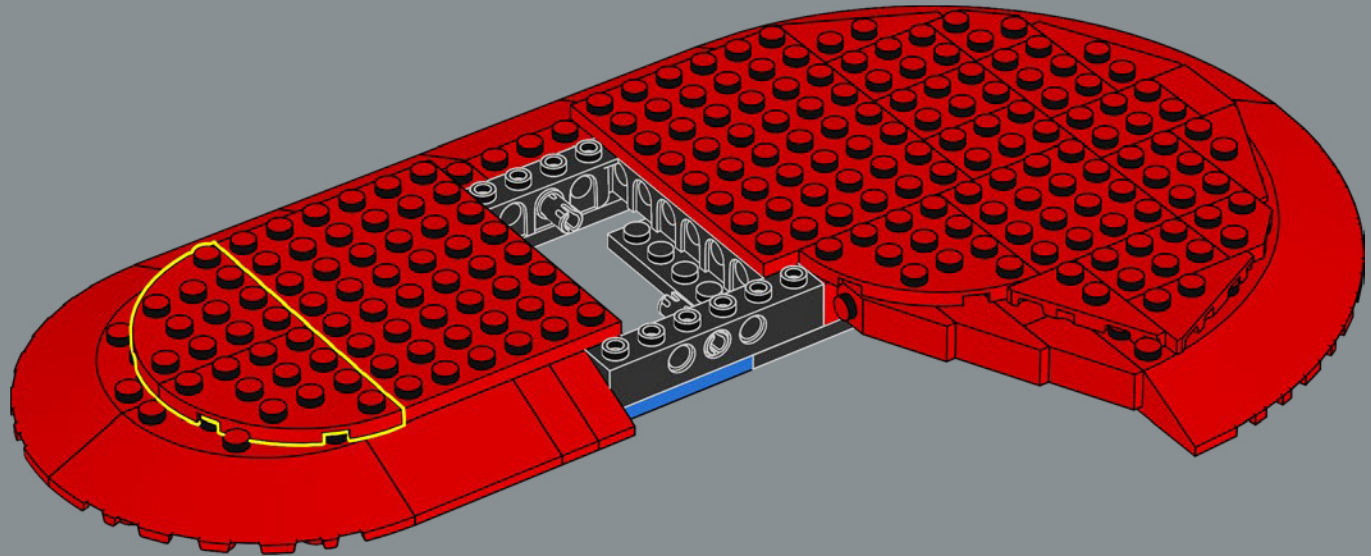

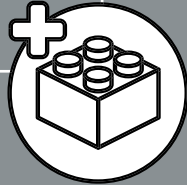
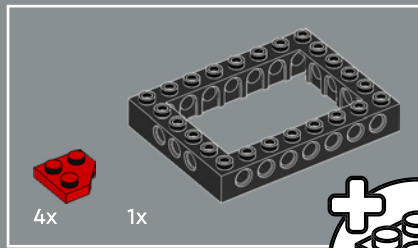

296

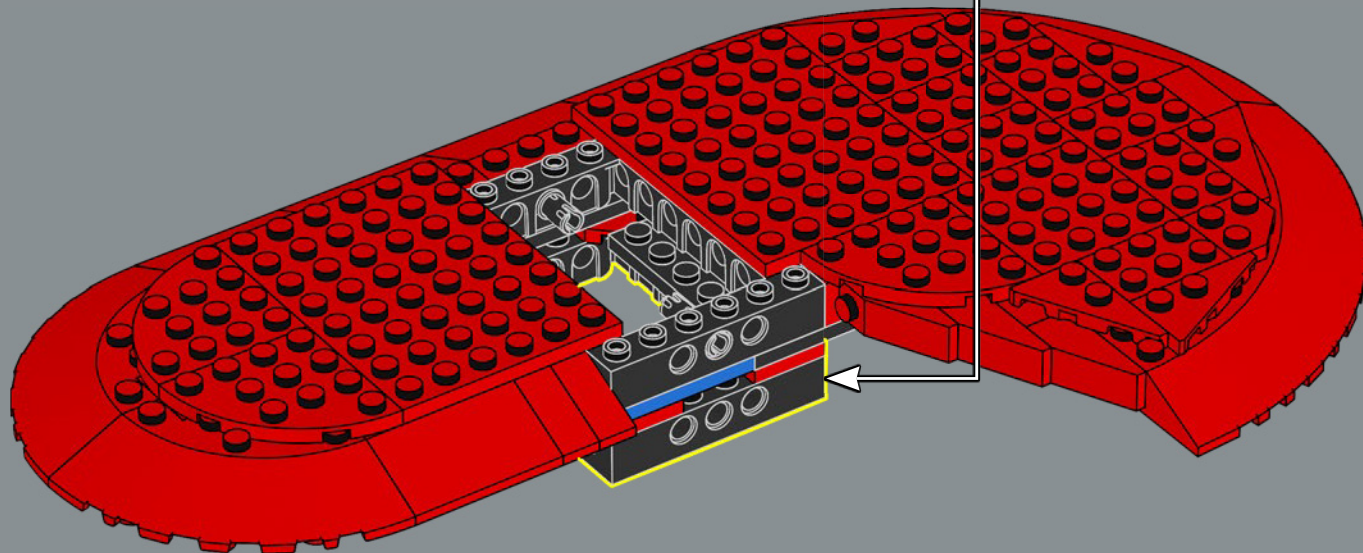
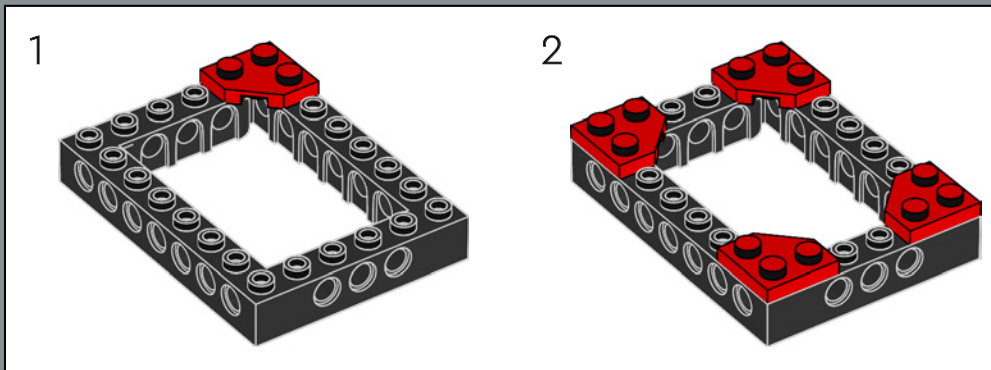



2x

297

The Marvel No-Prize was pioneered by Stan Lee in the 1960s as a recognition for spotting continuity errors in the comics. Today, the prize is awarded for charitable works and "meritorious service to Marvel above and beyond the call of duty."

Le No-Prize de Marvel a été créé par Stan Lee dans les années 1960 pour récompenser les personnes ayant repéré des erreurs de continuité dans les bandes dessinées. Aujourd'hui, le prix est décerné pour des œuvres caritatives et des « services méritoires rendus à Marvel au-delà de l'appel du devoir ».

El premio No-Prize de Marvel fue creado por Stan Lee en los años 60 como reconocimiento por detectar errores de continuidad en los cómics. En la actualidad, el premio se concede por obras benéficas y "servicios meritorios a Marvel por encima y más allá del deber".

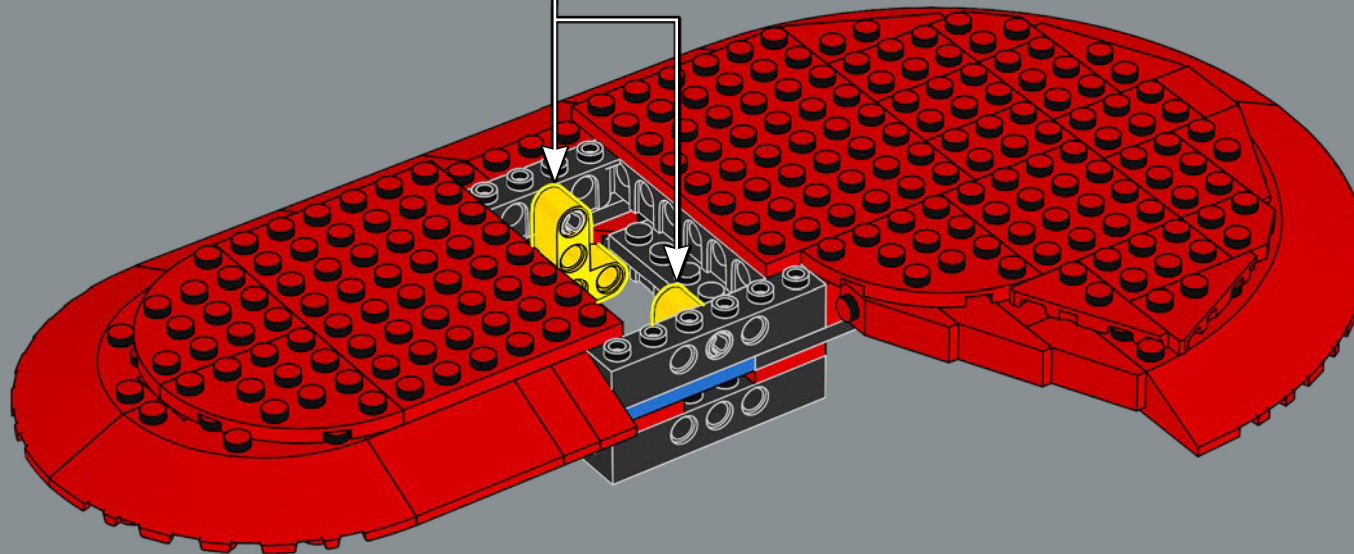
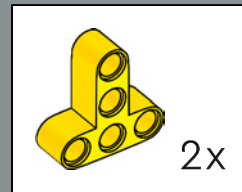



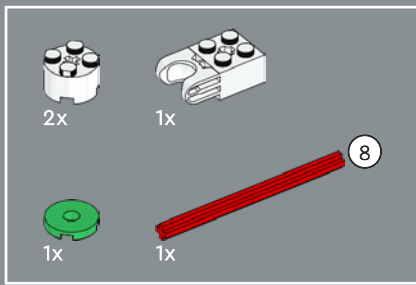

298

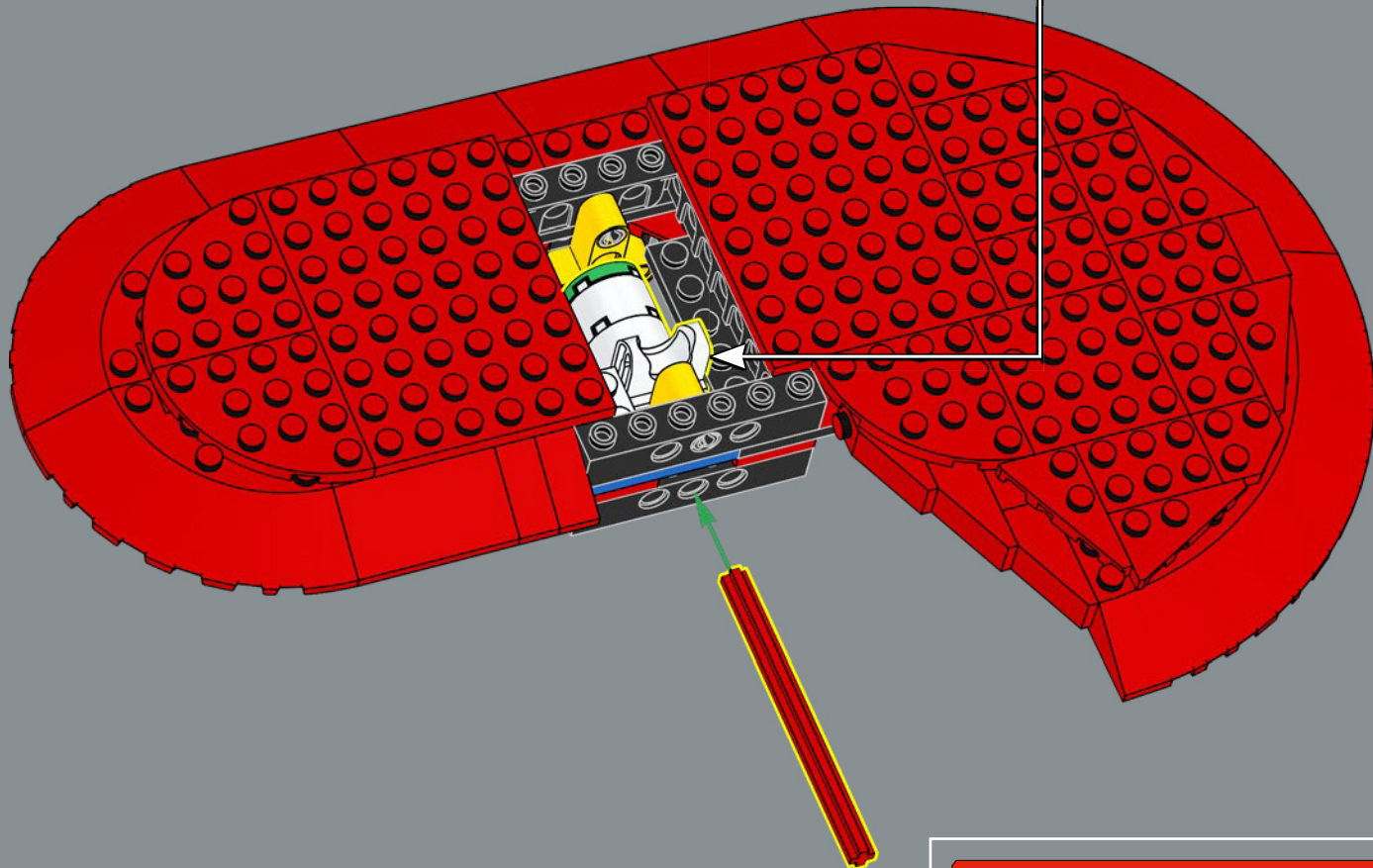
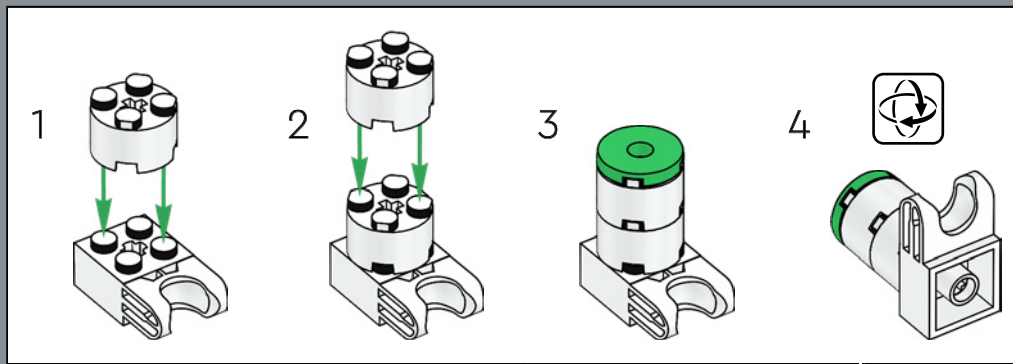

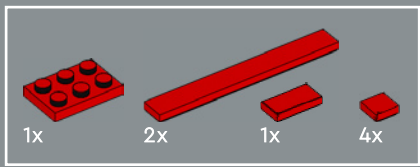

299

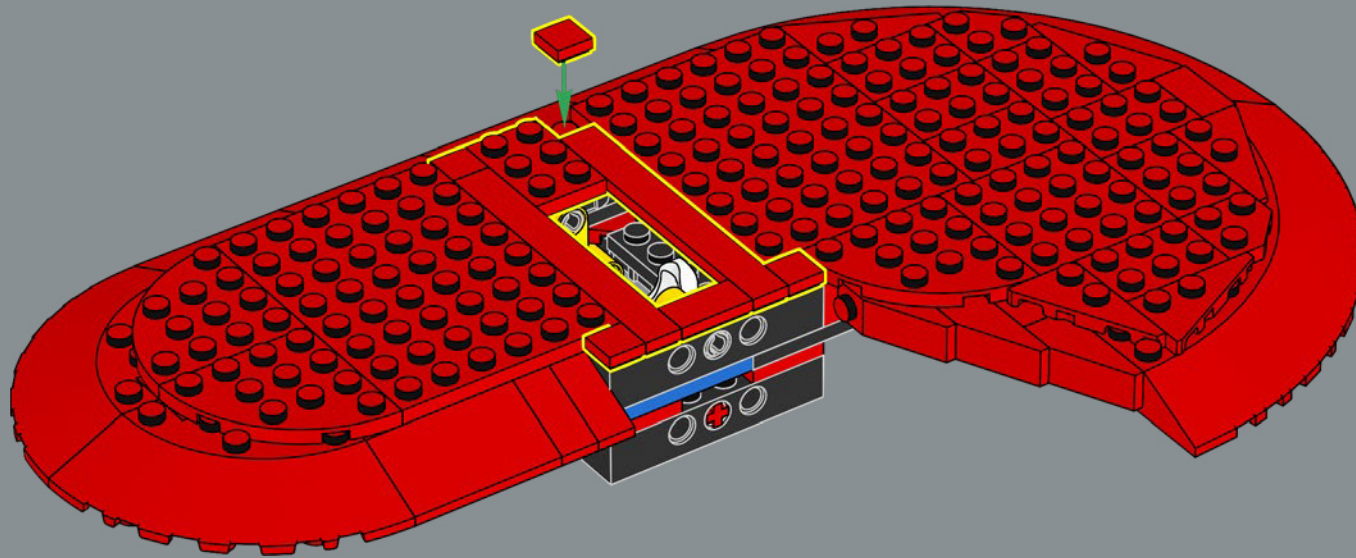

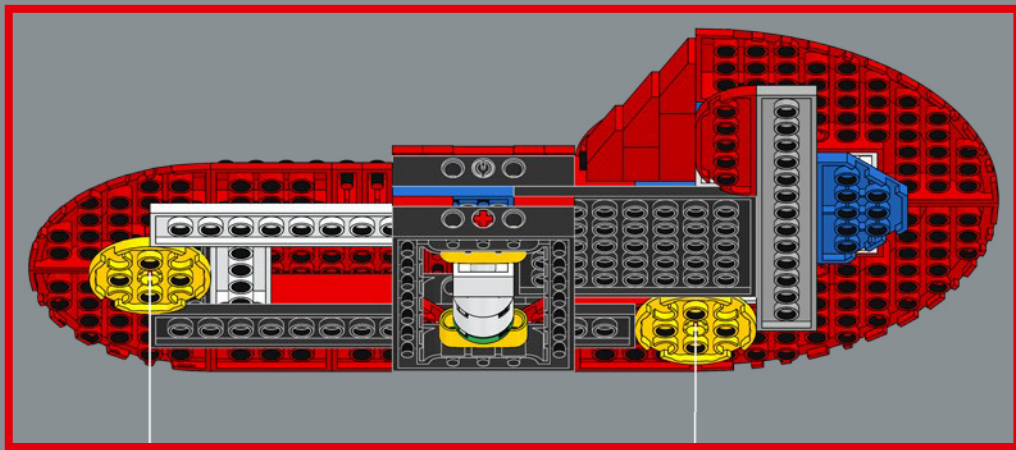

300

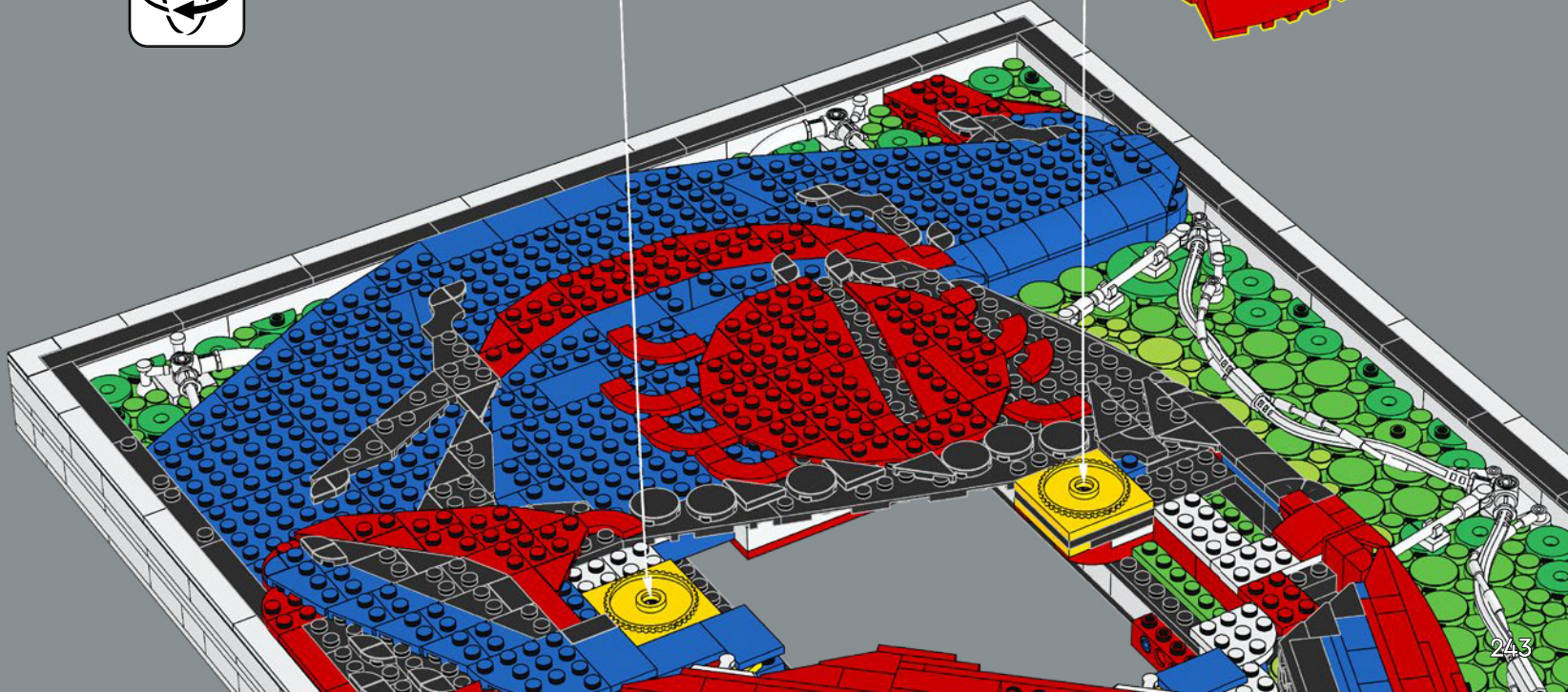
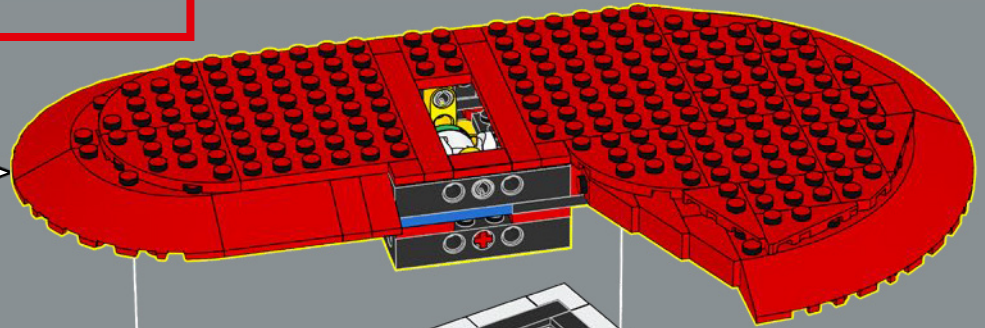

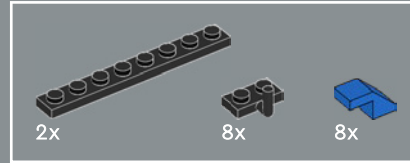
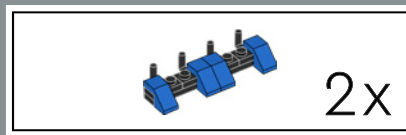

301

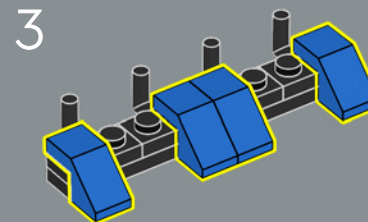
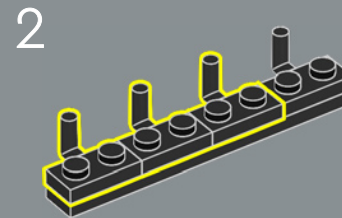
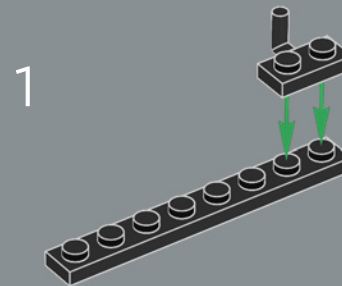

2x

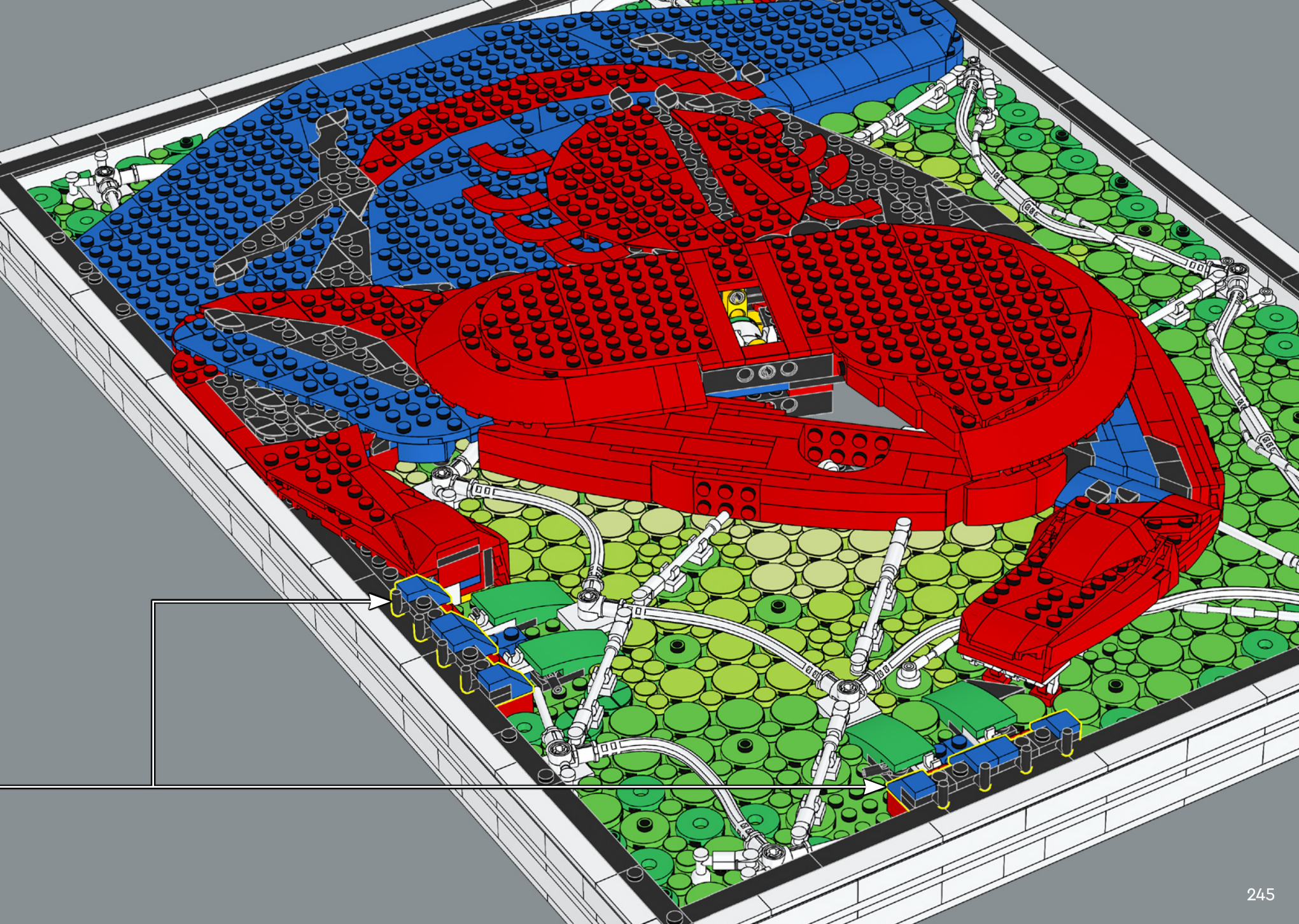

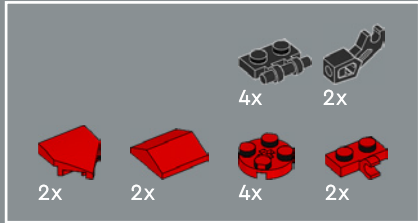
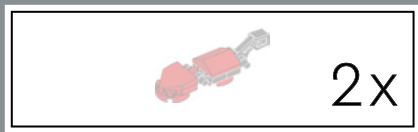

302

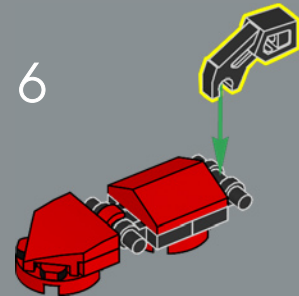
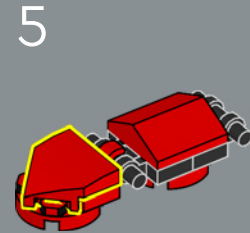
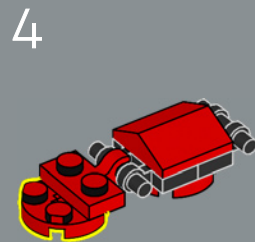
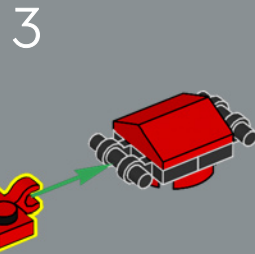
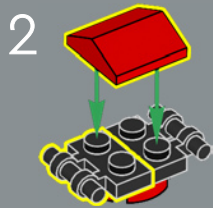
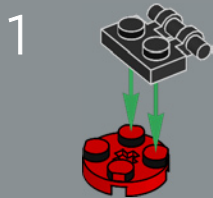

2x

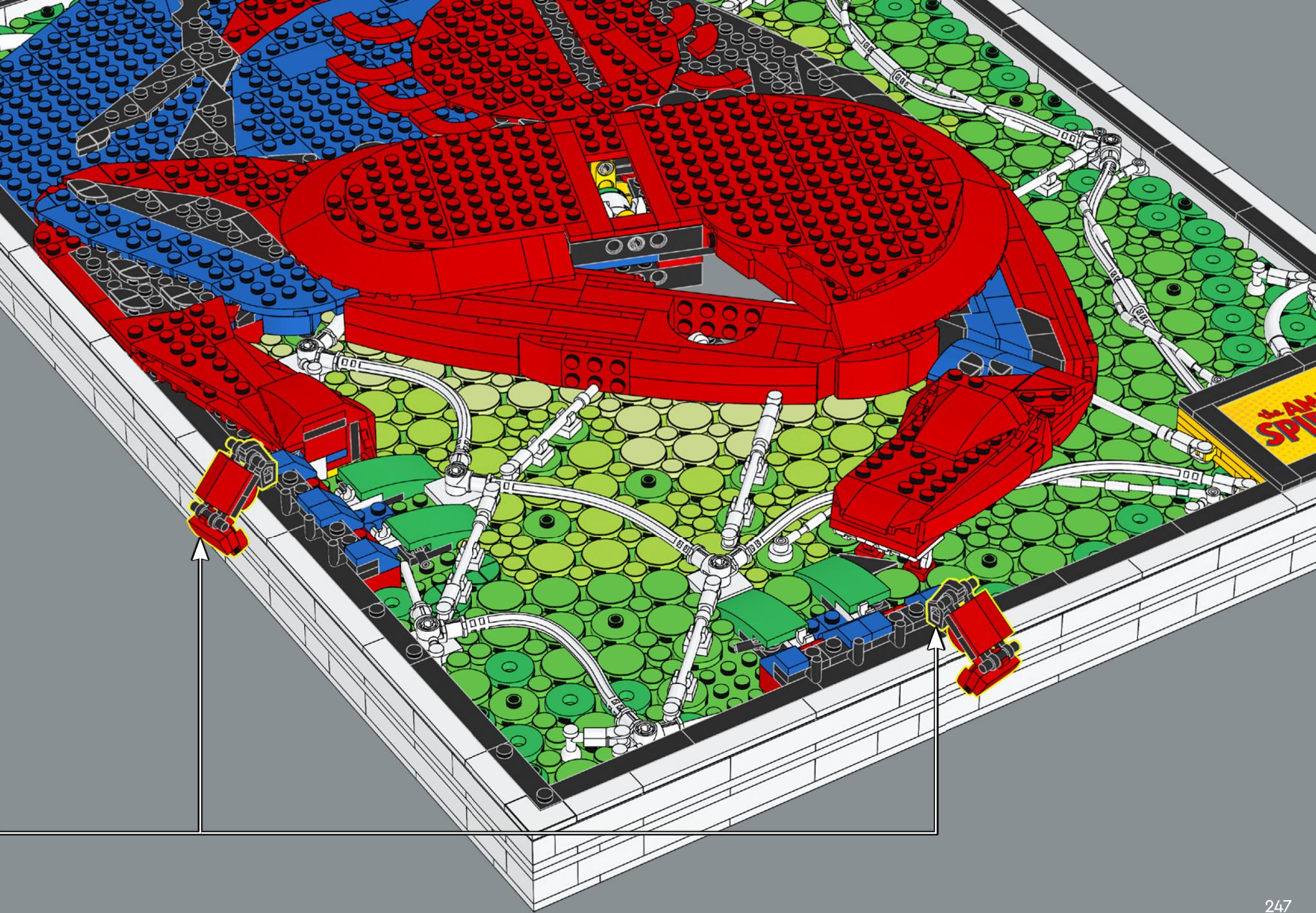

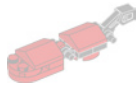

6x



12x



12x



6x



6x



12x



6x

303

1

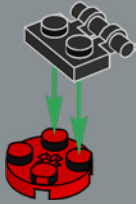

2

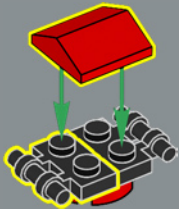

3

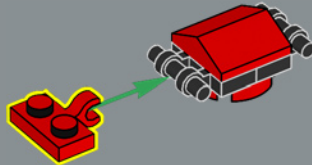

4

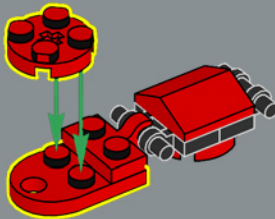

5

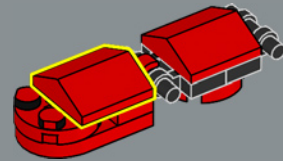

6

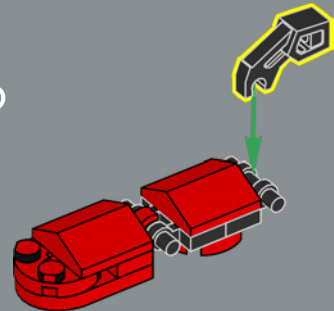

6x

Spider-Man's exposure to mutated spider venom allows him to mentally control the flux of interatomic attraction between molecular boundary layers. Put simply, he can crawl on walls!

L'exposition de Spider-Man au venin d'araignée mutée lui permet de contrôler mentalement le flux d'attraction interatomique entre les couches moléculaires limites. En d'autres termes, il peut ramper sur les murs !

La exposición de Spider-Man al veneno de una araña mutada le permite controlar mentalmente el flujo de atracción interatómica entre las capas moleculares de límite. En pocas palabras, ¡puede moverse por las paredes!



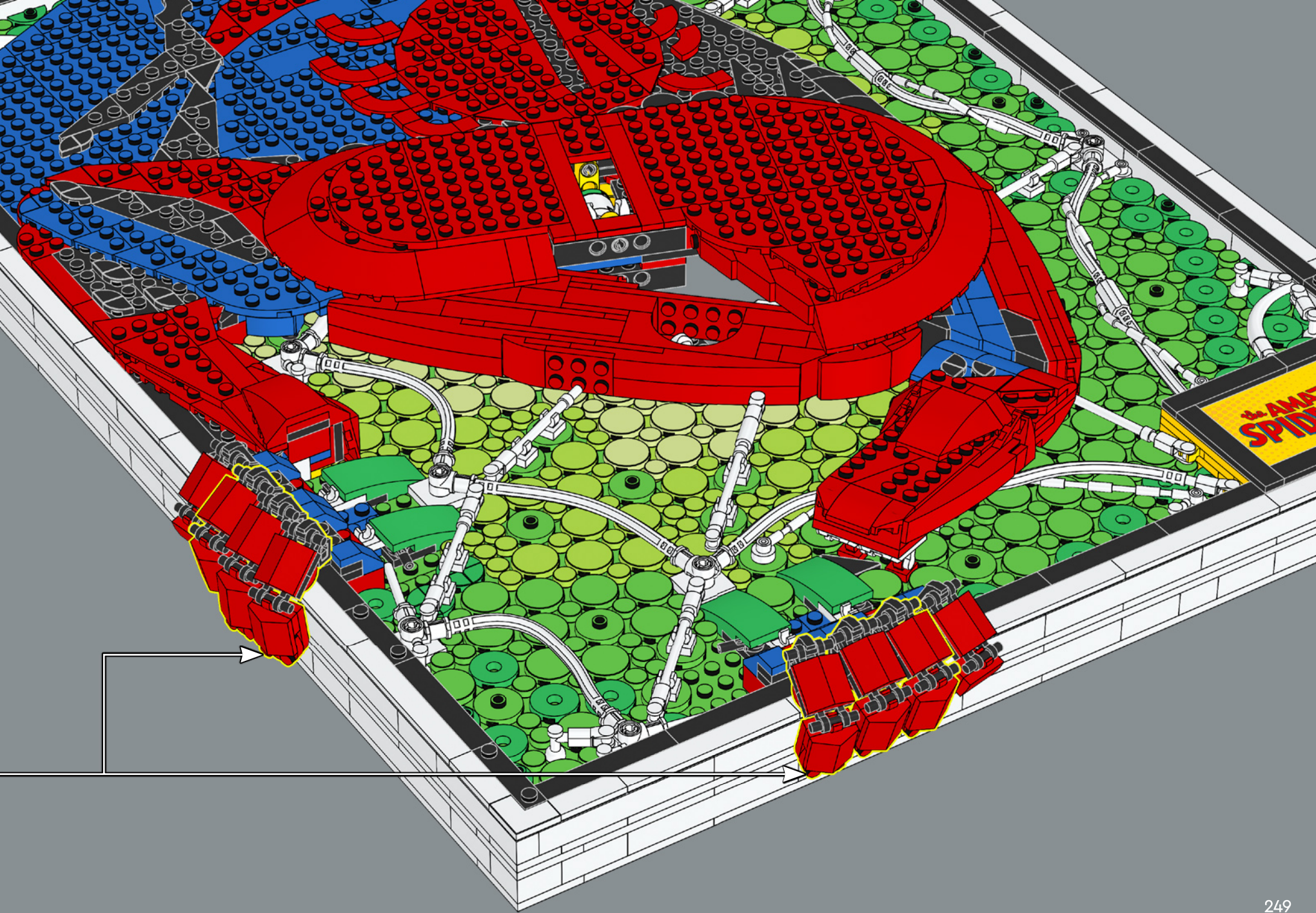

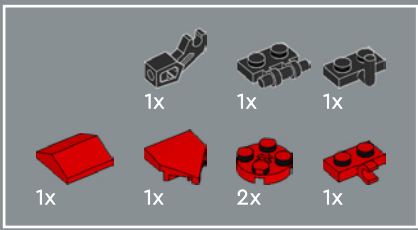

# 304

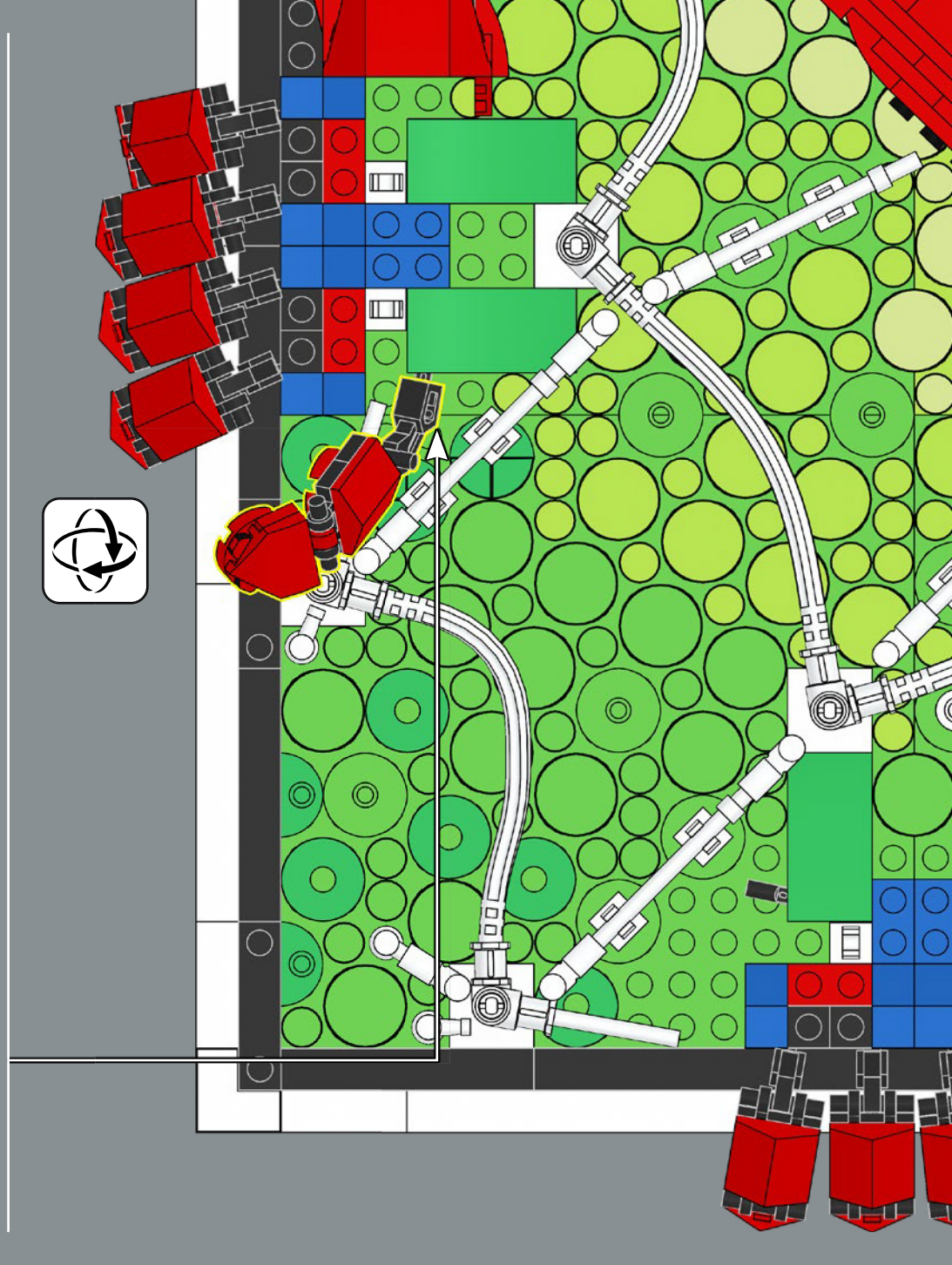
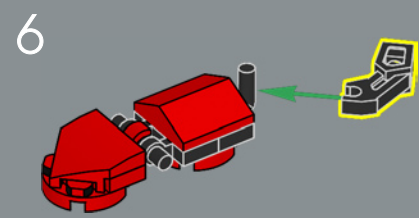
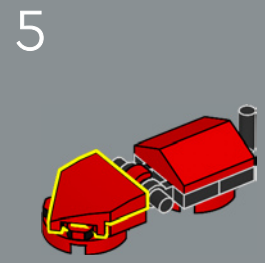
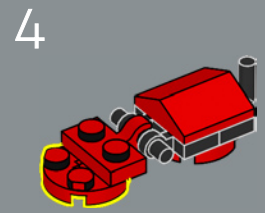
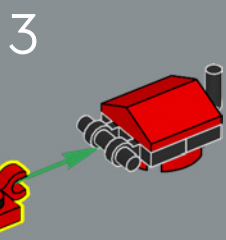
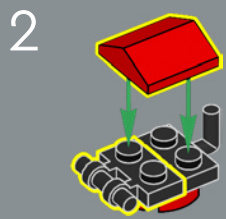
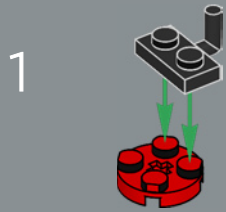

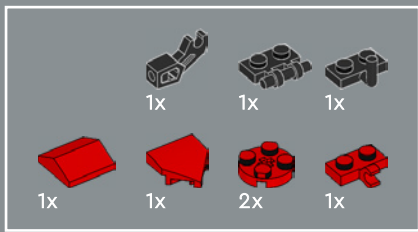

305

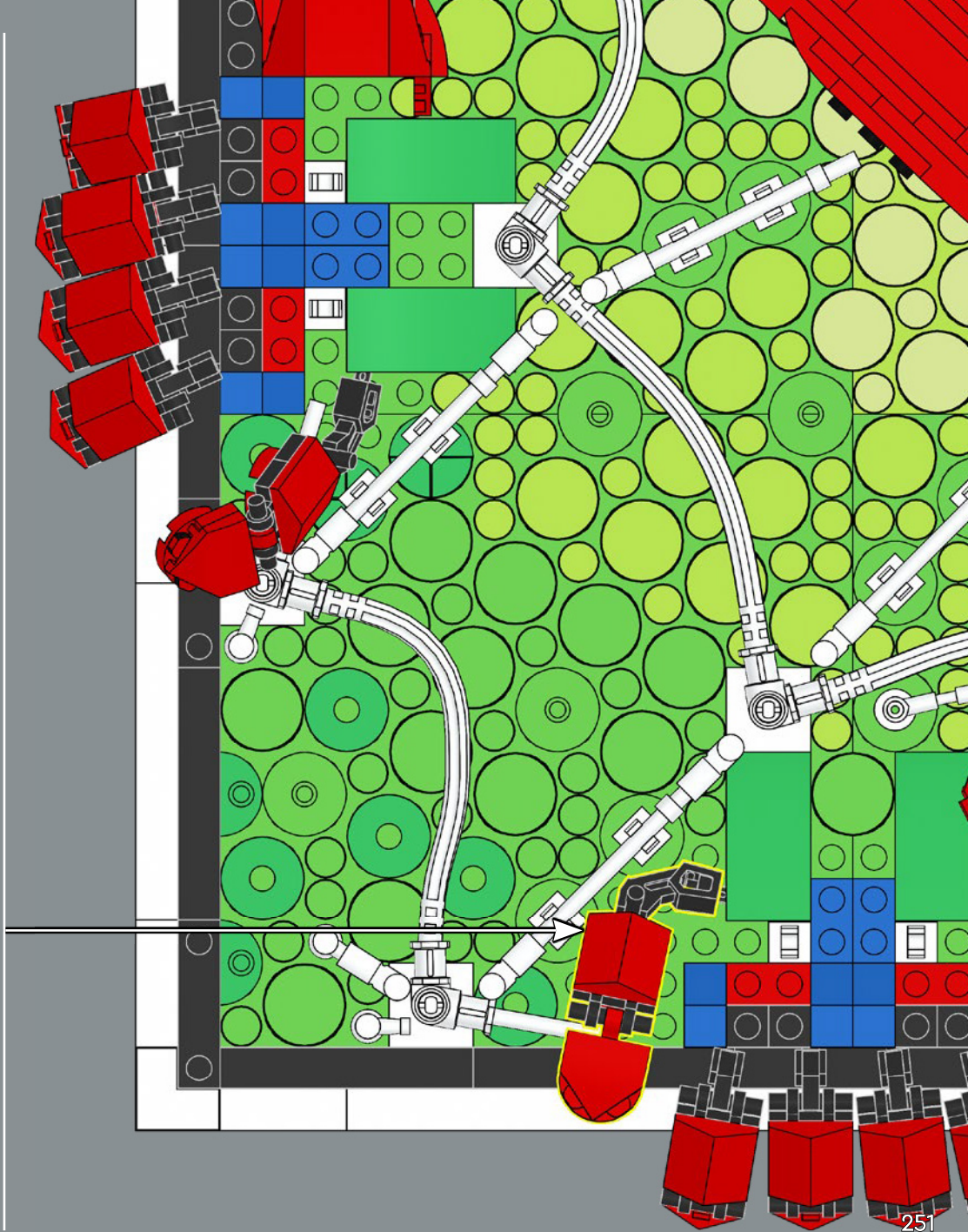
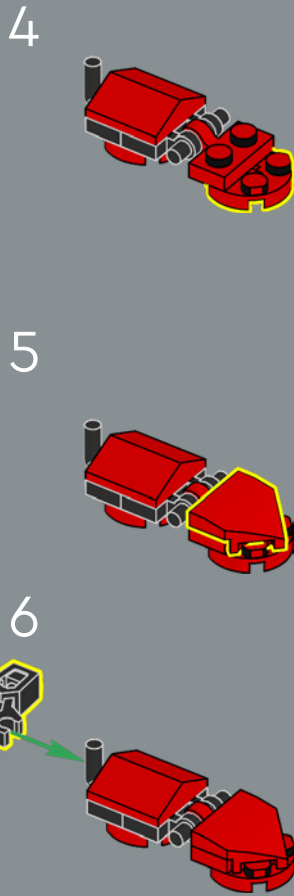
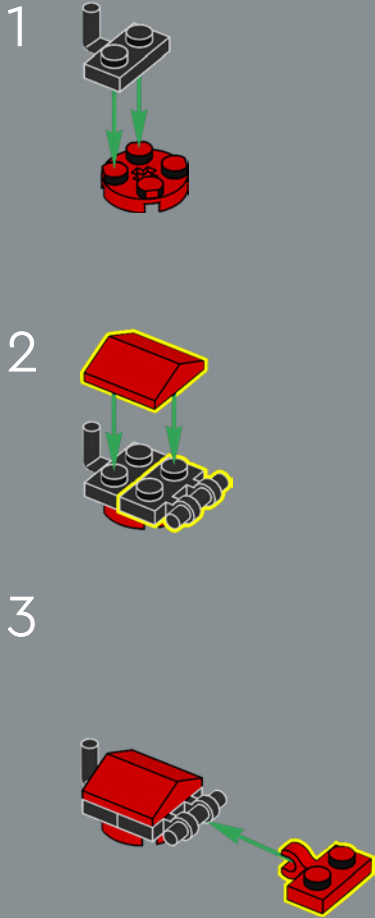

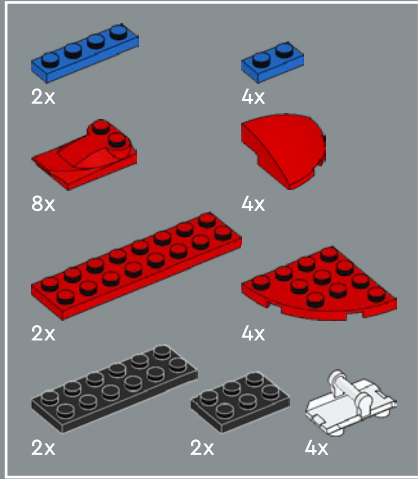
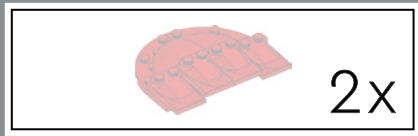

306

1

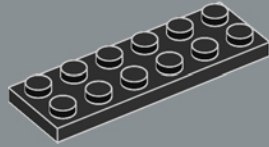

2

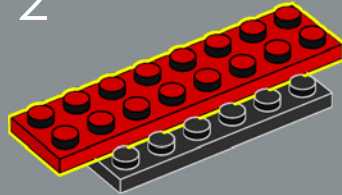

3

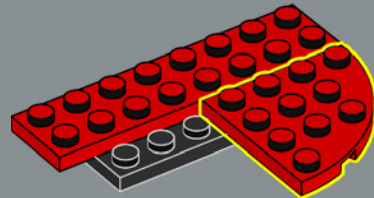

4

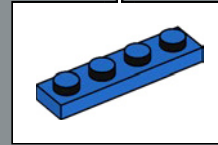
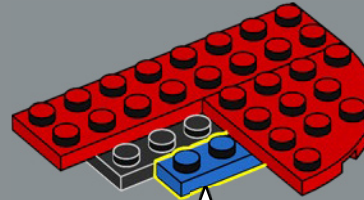

5

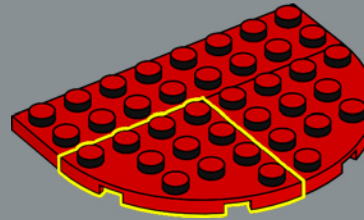

6

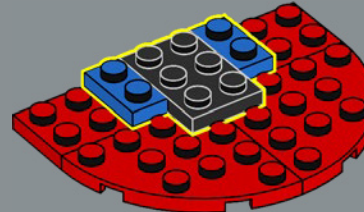

7

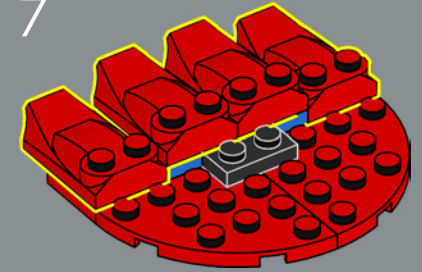

8

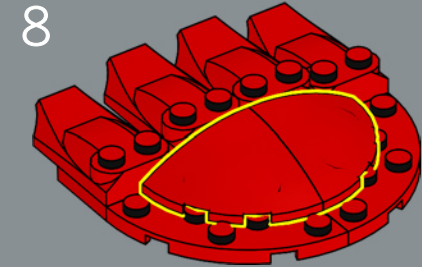

9

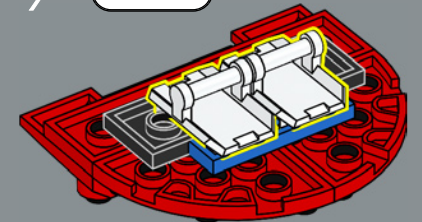

2x

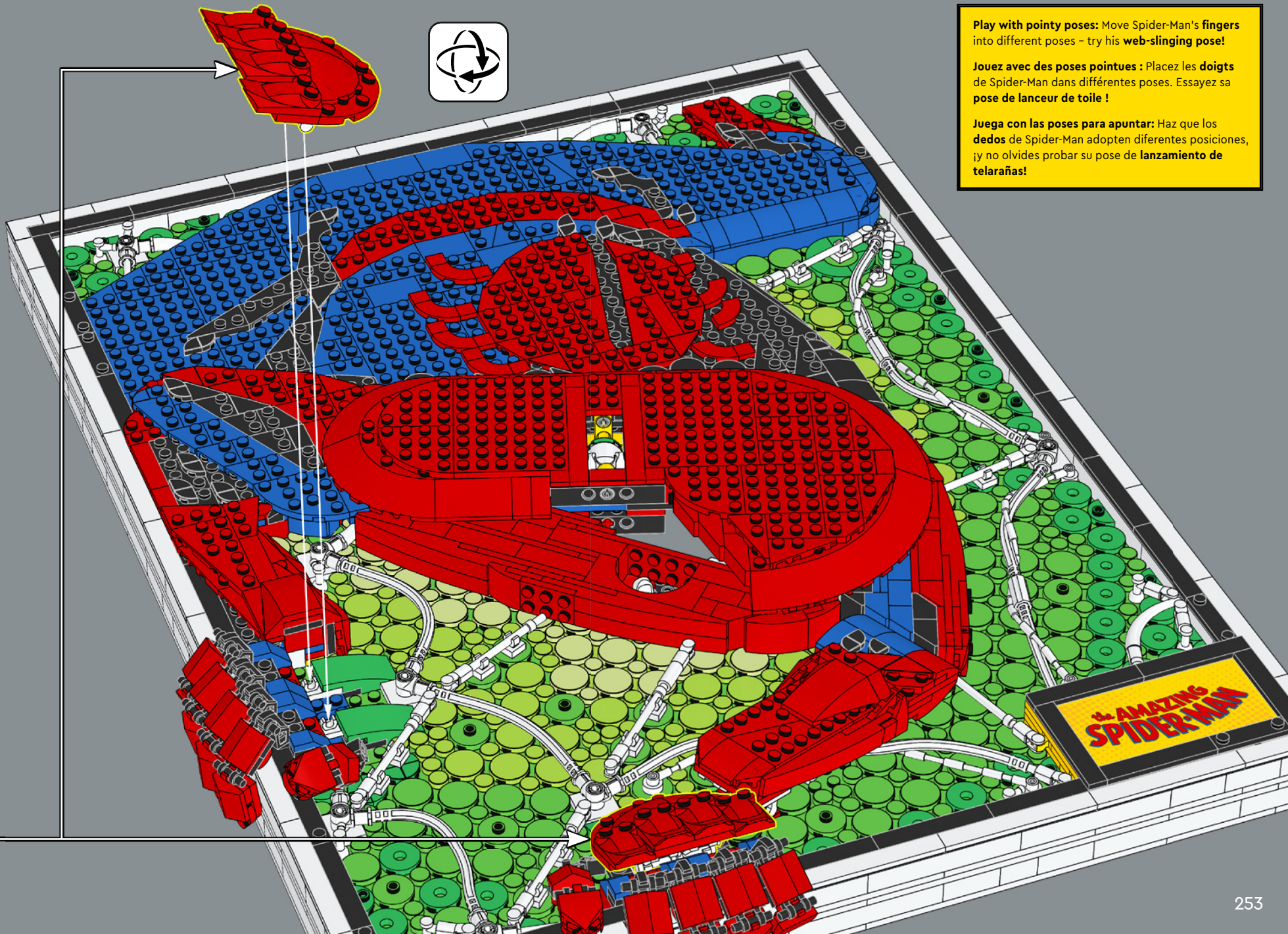

**Play with pointy poses:** Move Spider-Man's fingers into different poses – try his web-slinging pose!

**Jouez avec des poses pointues :** Placez les doigts de Spider-Man dans différentes poses. Essayez sa pose de lanceur de toile !

**Juega con las poses para apuntar:** Haz que los dedos de Spider-Man adopten diferentes posiciones, ¡y no olvides probar su pose de lanzamiento de telarañas!

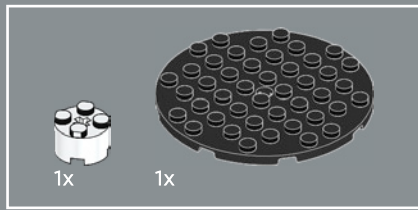
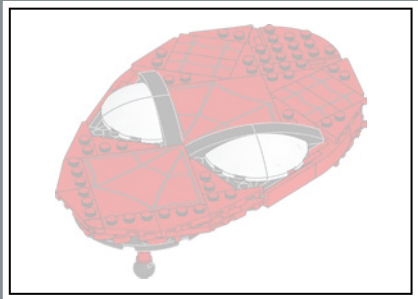

307

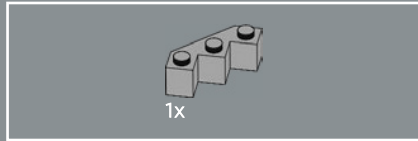

308

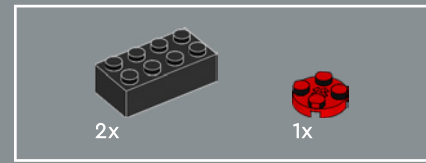
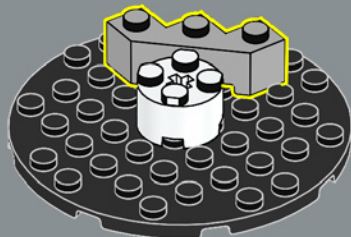

309

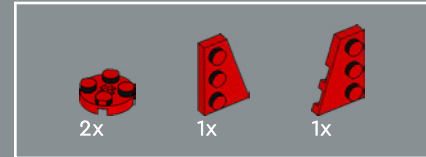
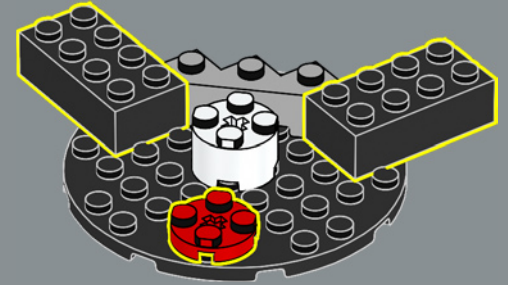

310

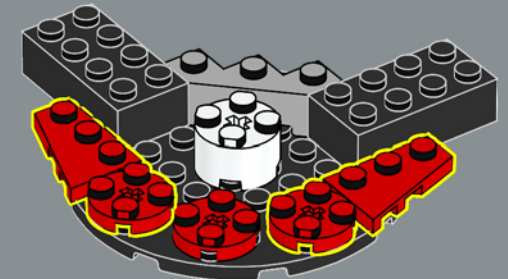

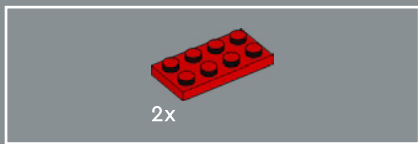

311

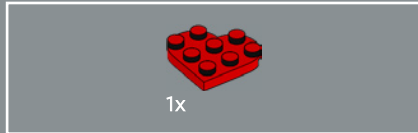
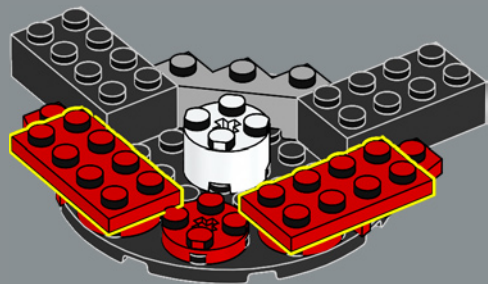

312

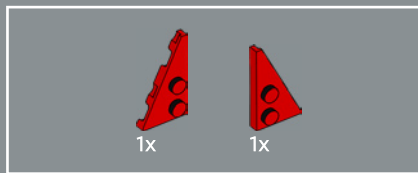
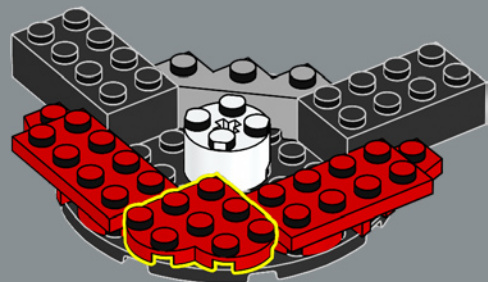

313

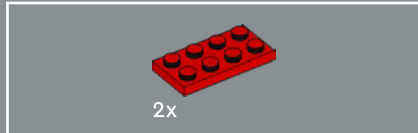
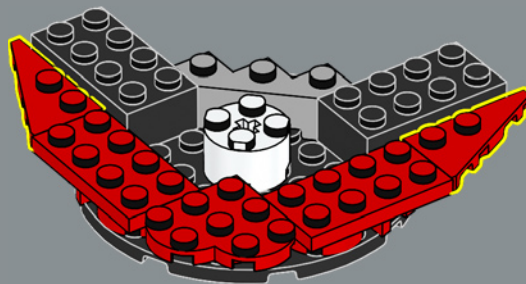

314

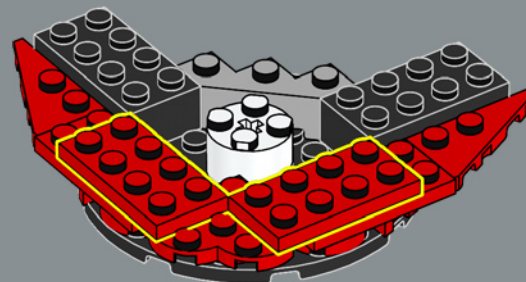

315

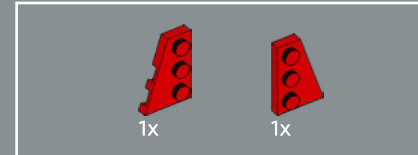
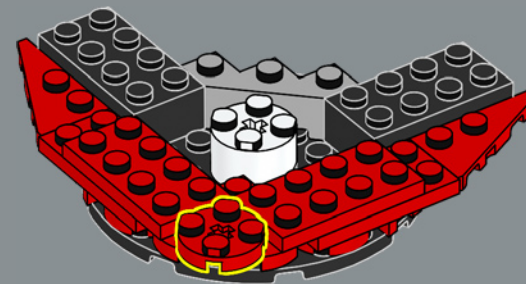

316

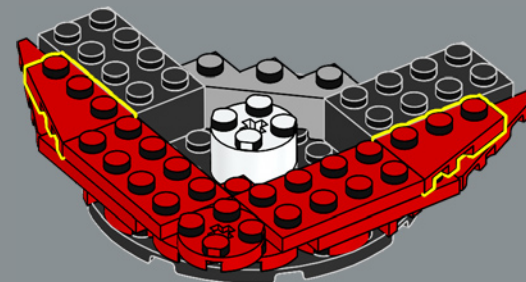

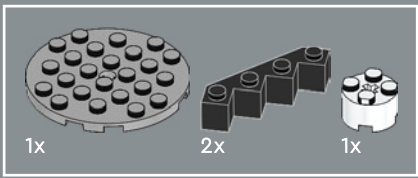

317

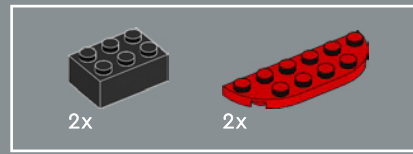
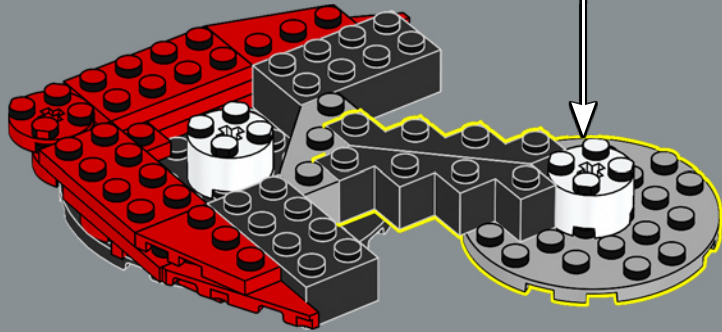
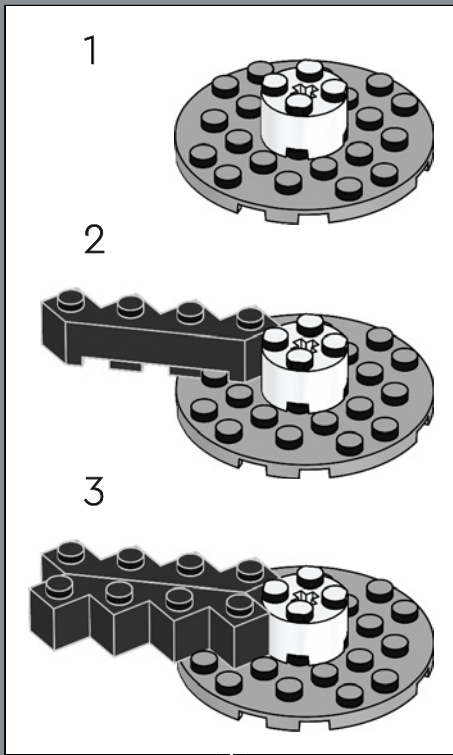

318

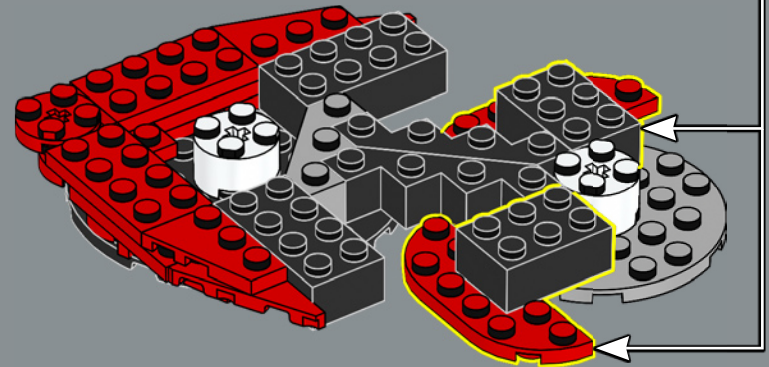
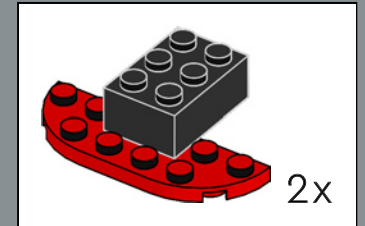



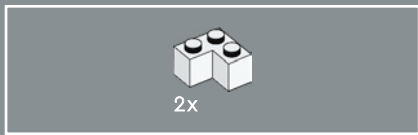

319

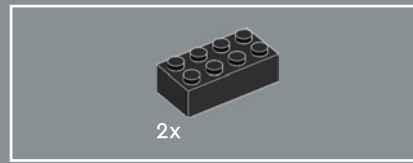
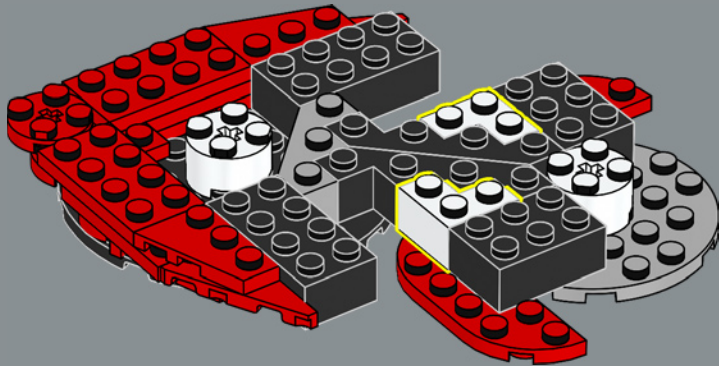

320

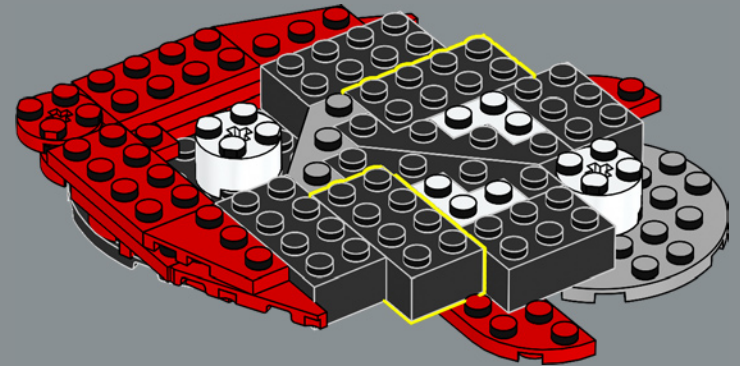



# 321

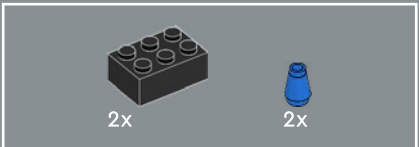
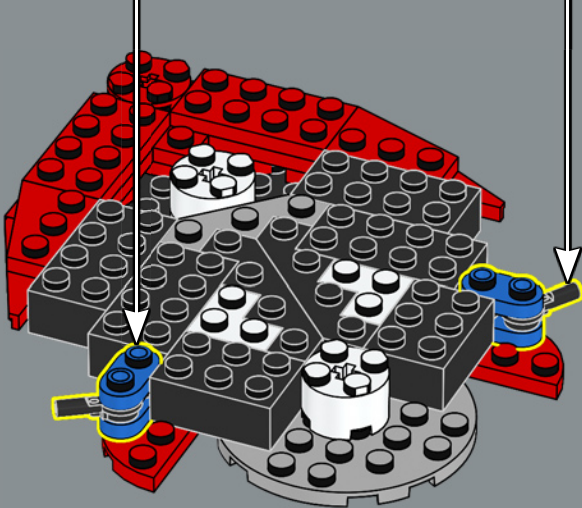
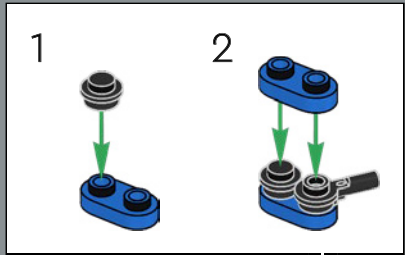
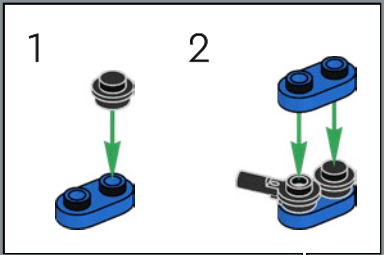

# 322

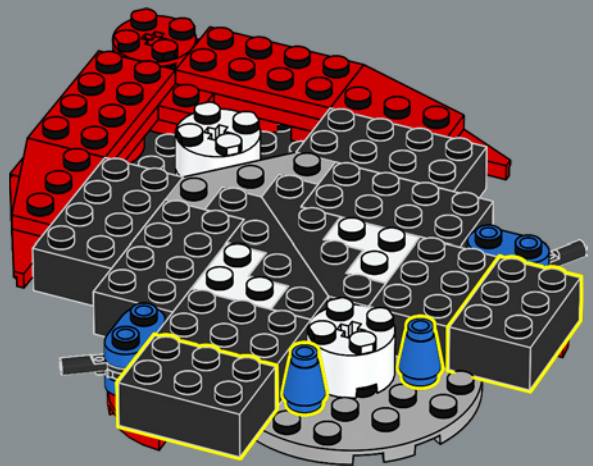

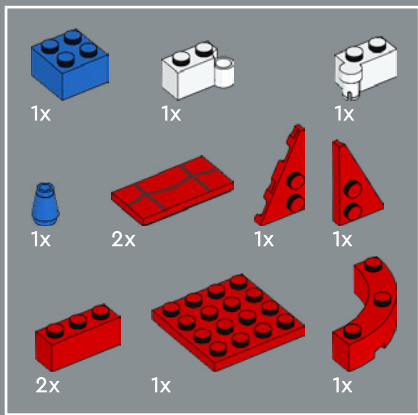

323

1

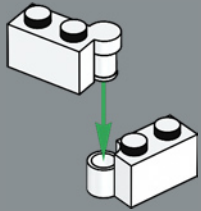

2

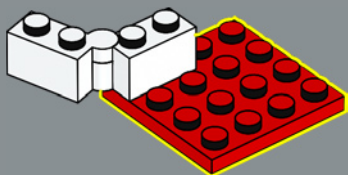

3

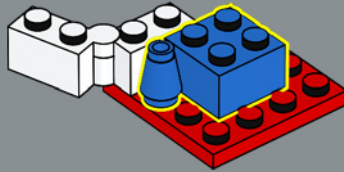

4

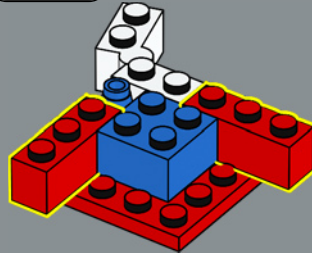

5

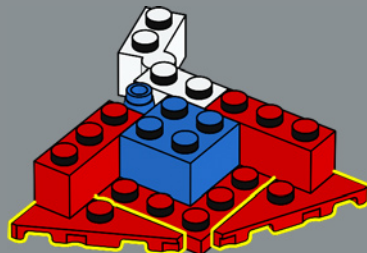

6

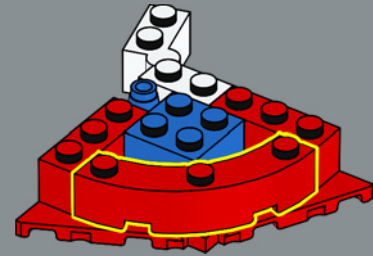

7

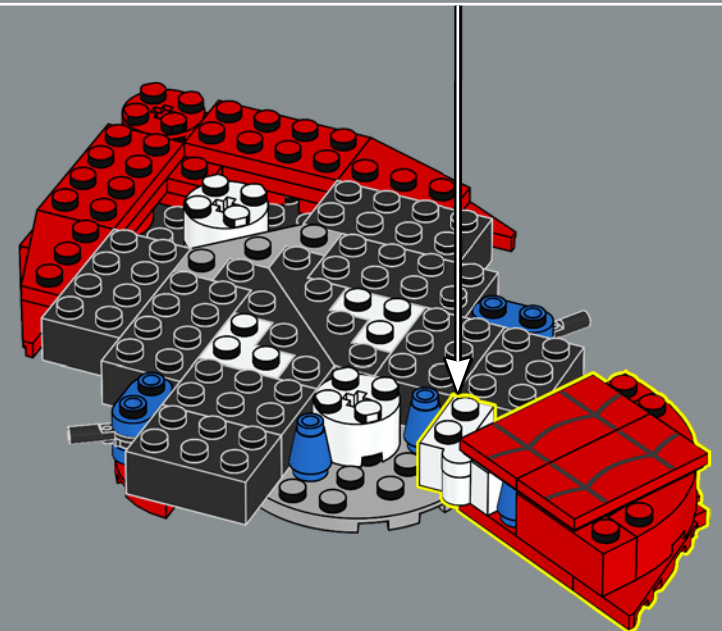
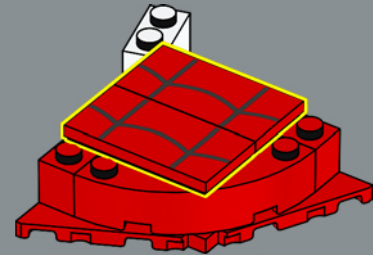

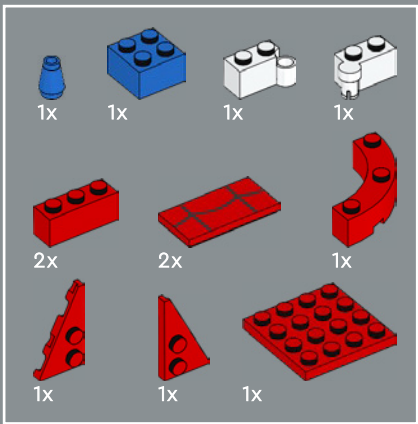

324

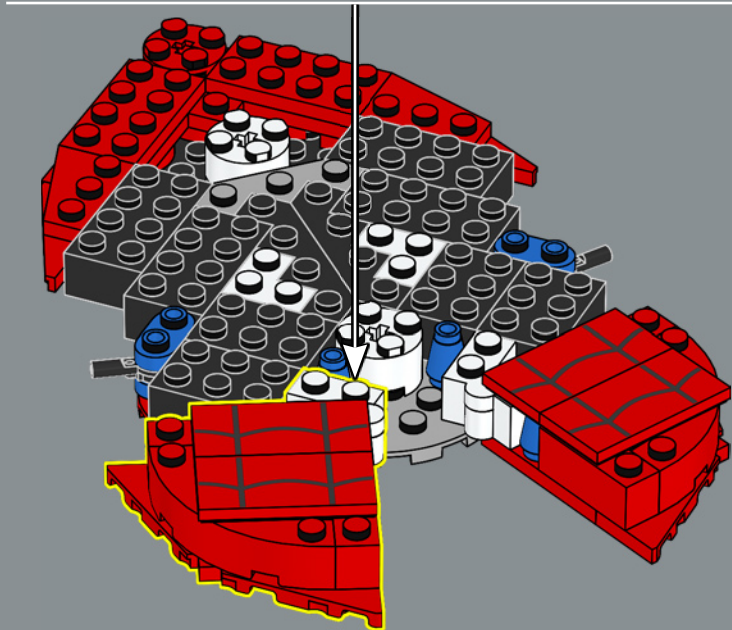
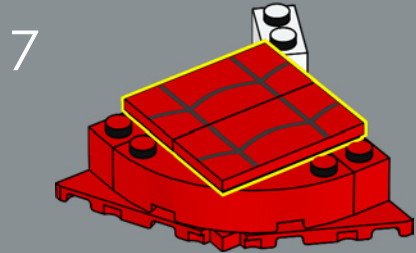
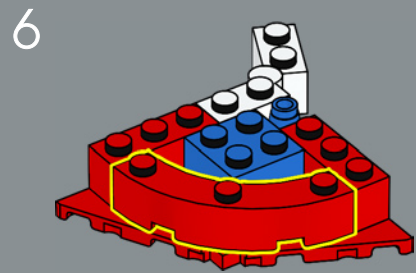
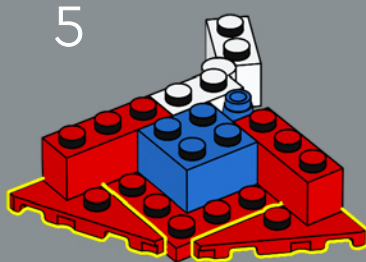
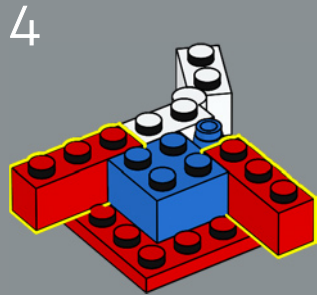
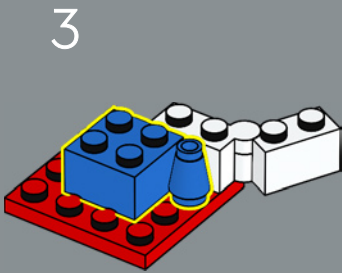
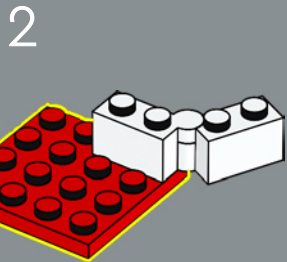
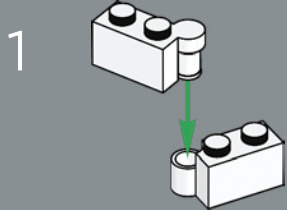

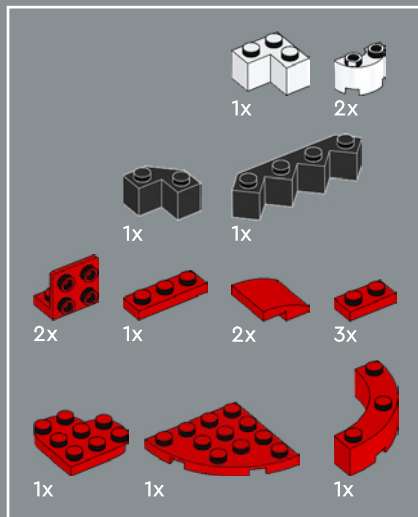

325

1



2

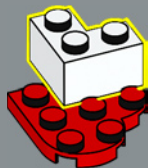

3

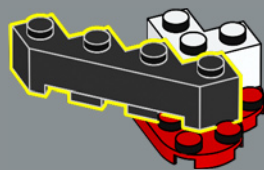

4

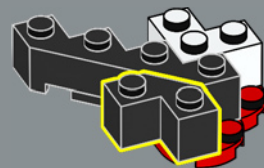

5

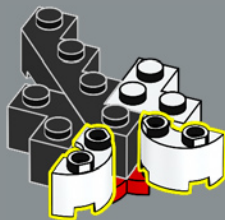

1

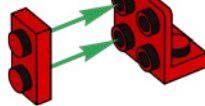

2

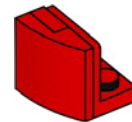

6

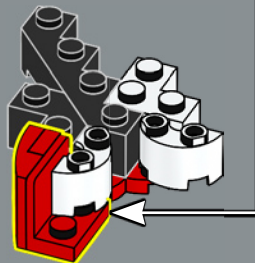

1

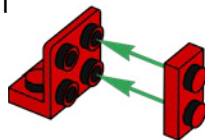

2

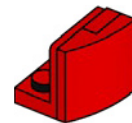

7

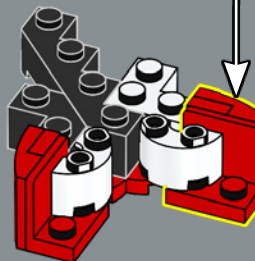

8

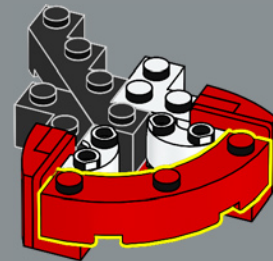

9

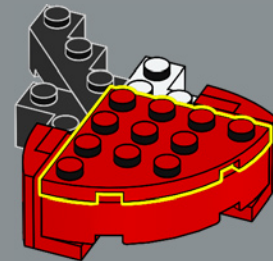

10

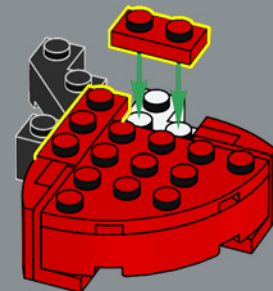

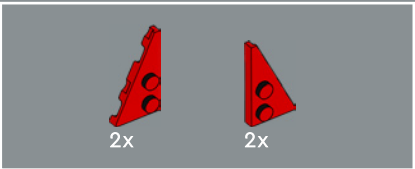

326

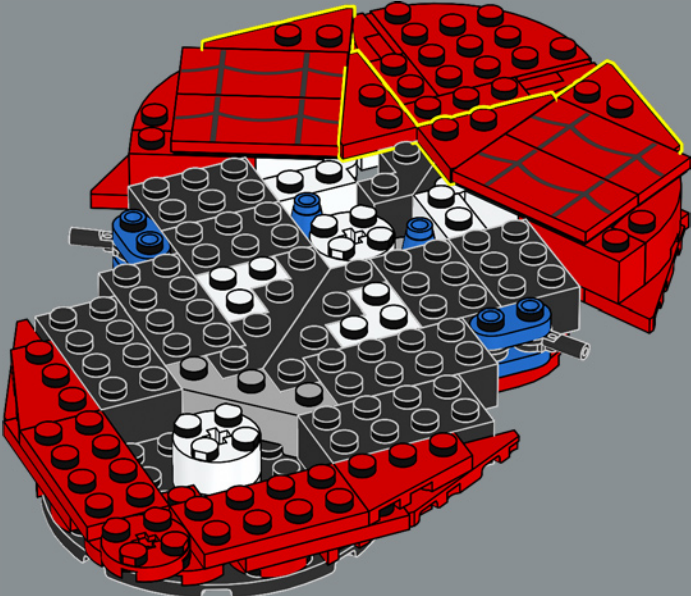
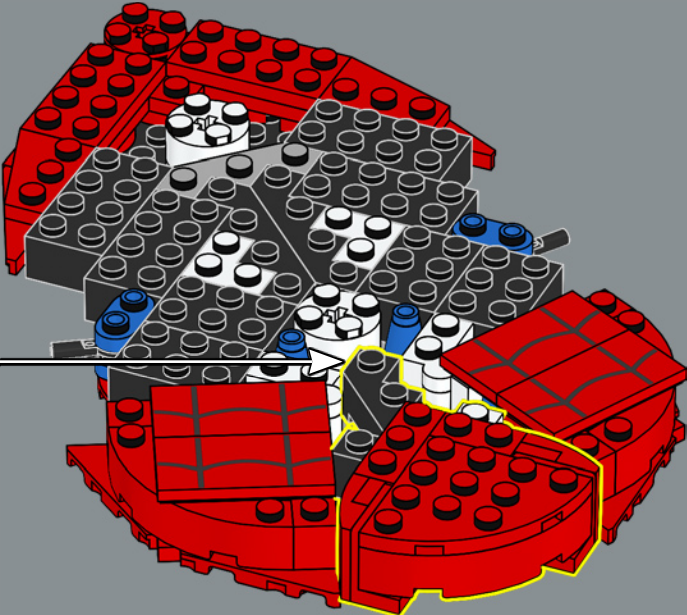

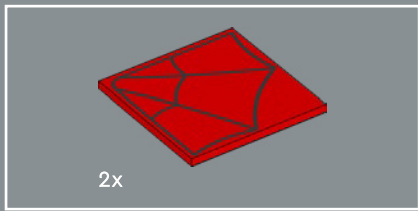

327

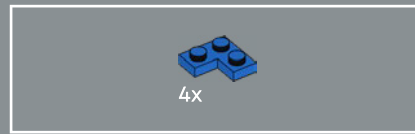
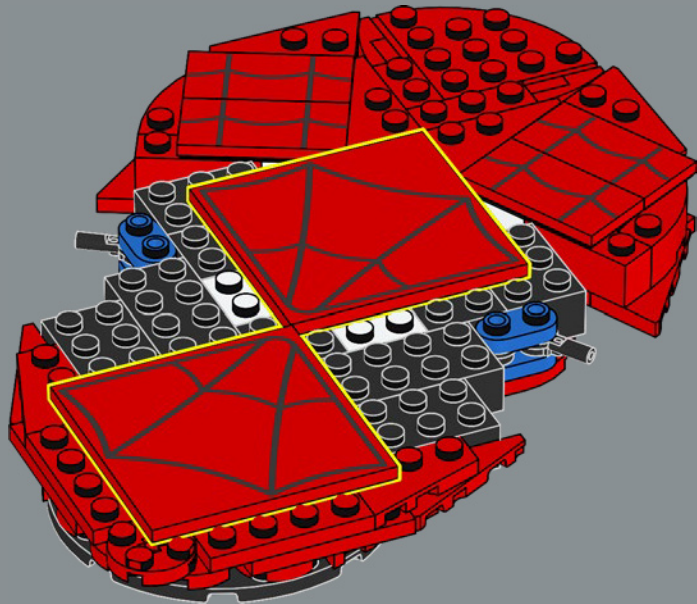

328

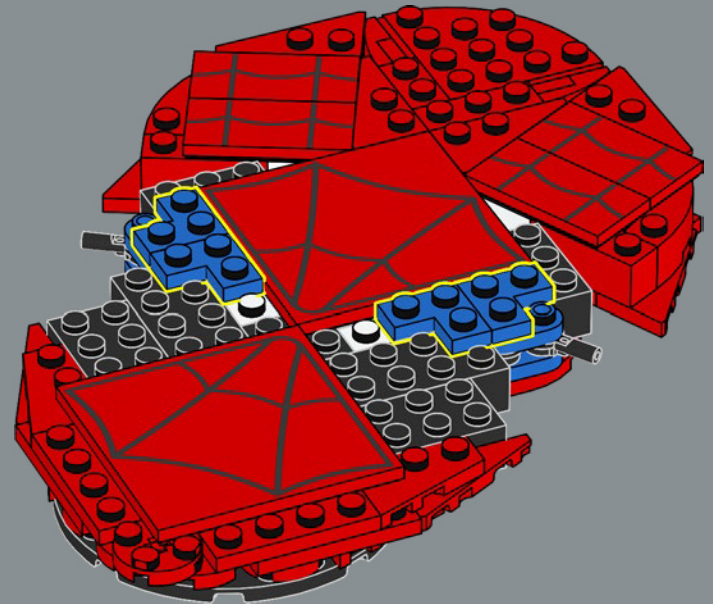

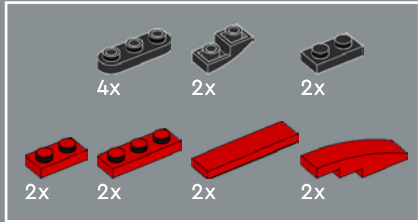
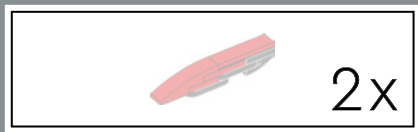

329

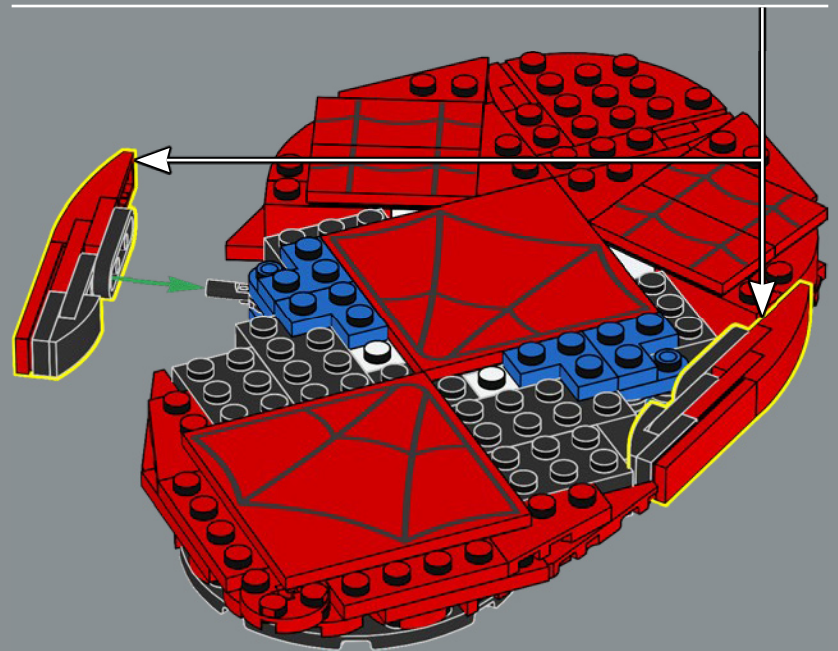
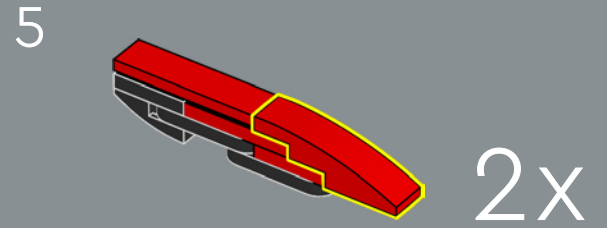
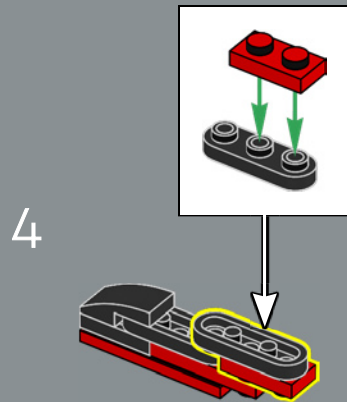
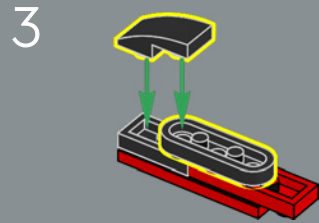
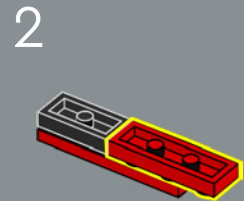
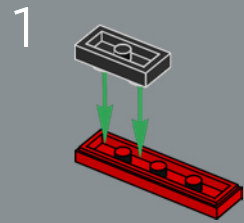





330

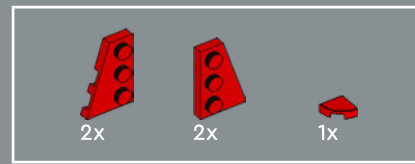
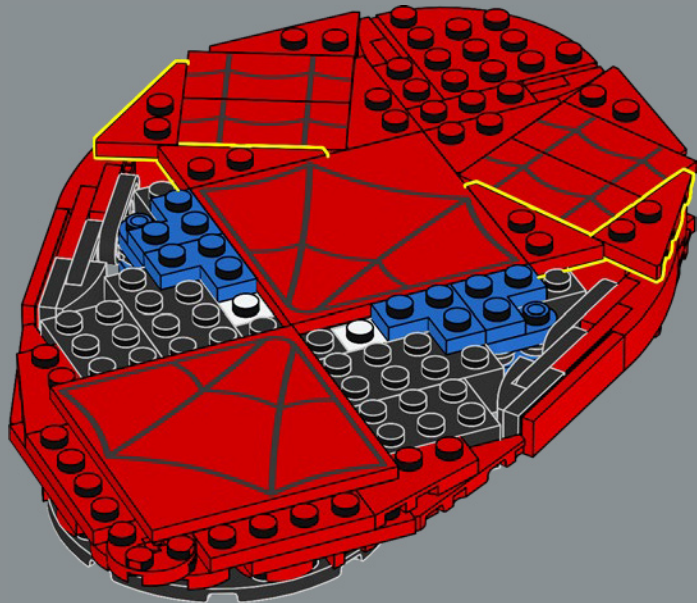

331

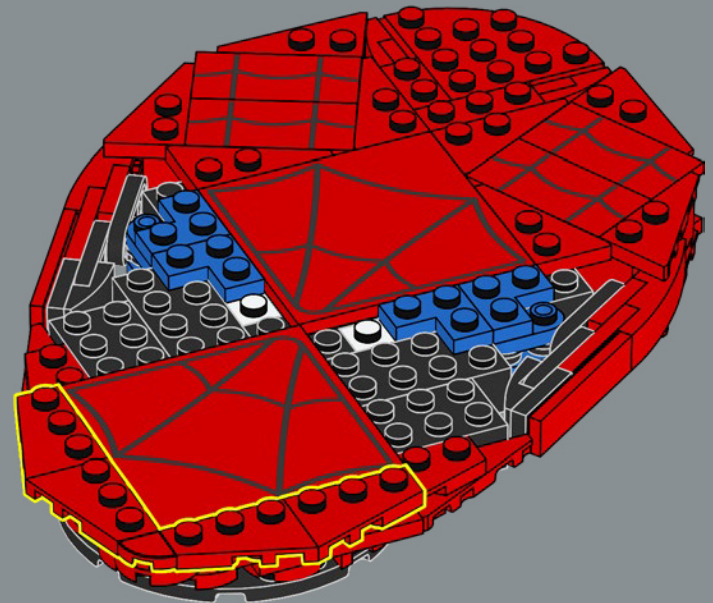

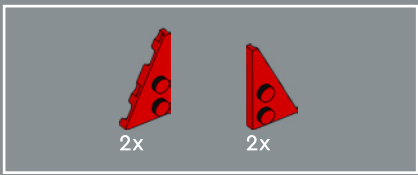

332

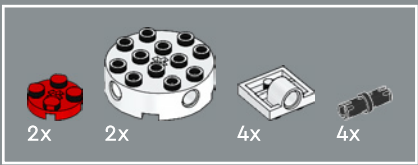
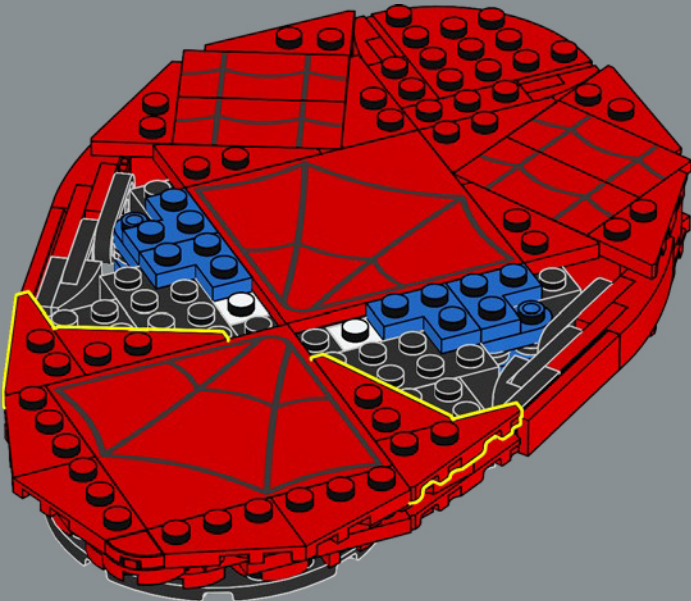

333

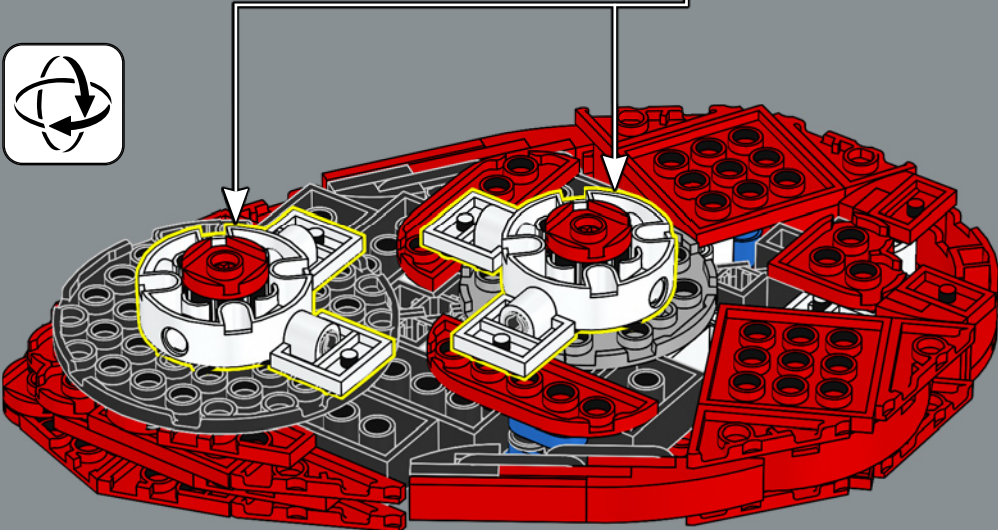
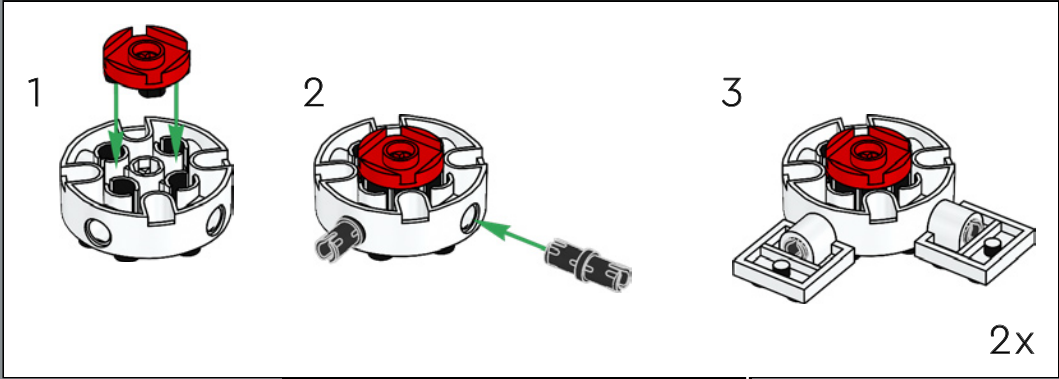

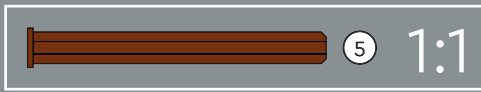
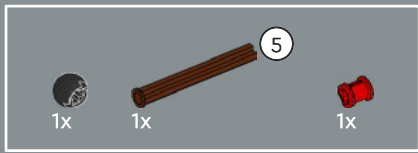

334

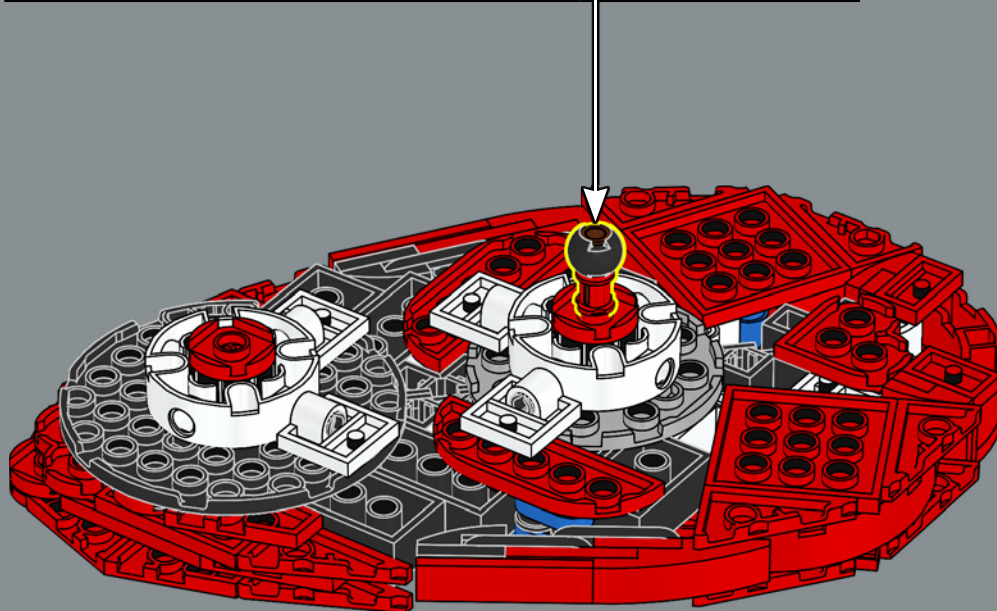
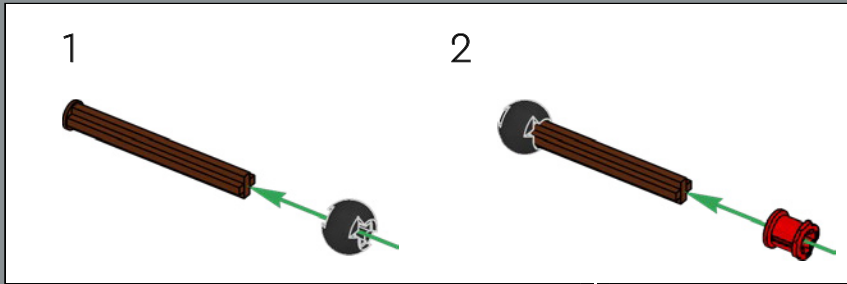

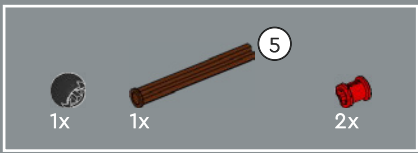

335

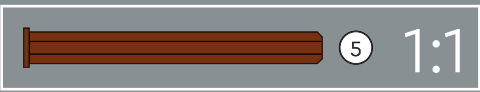

336

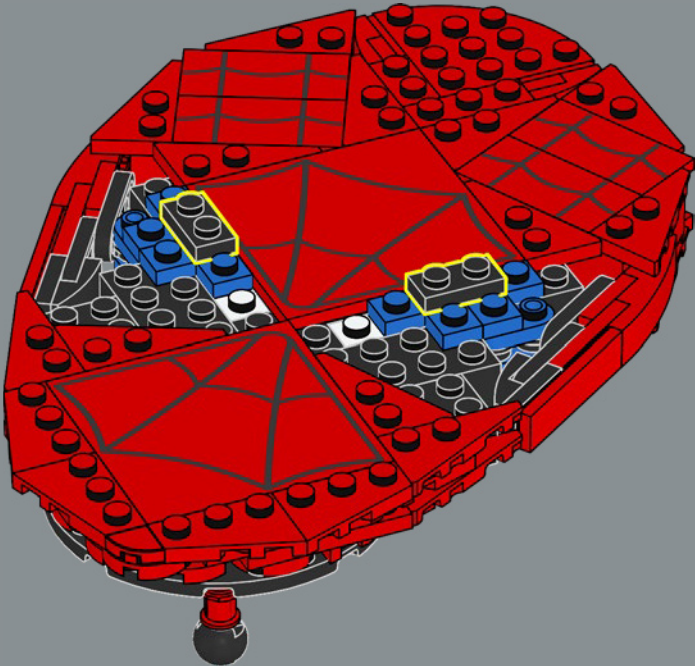
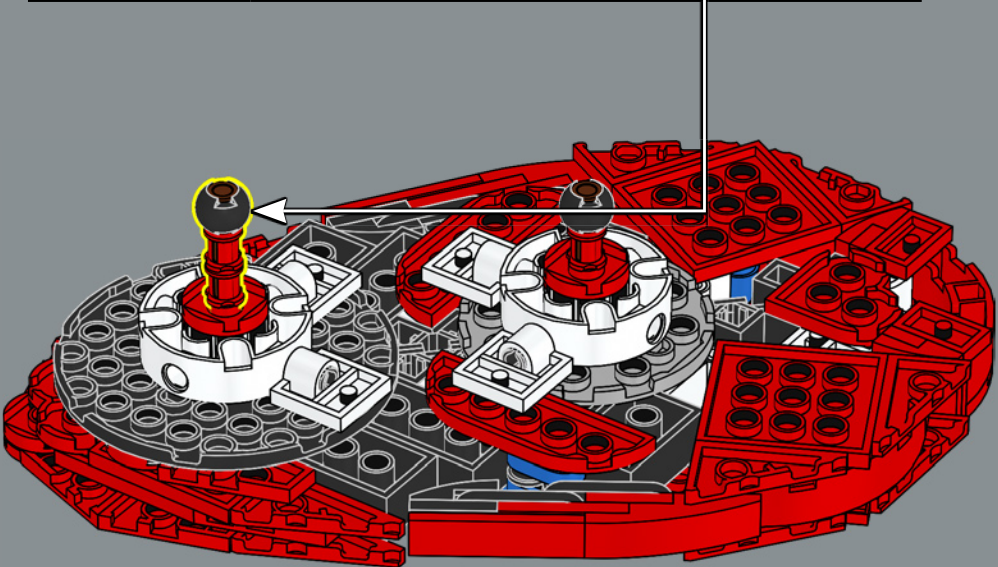
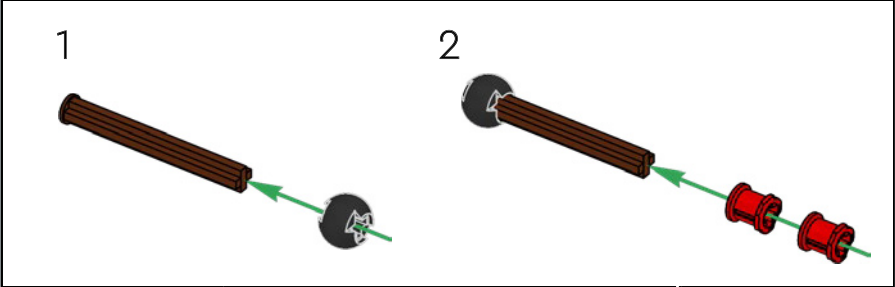



337

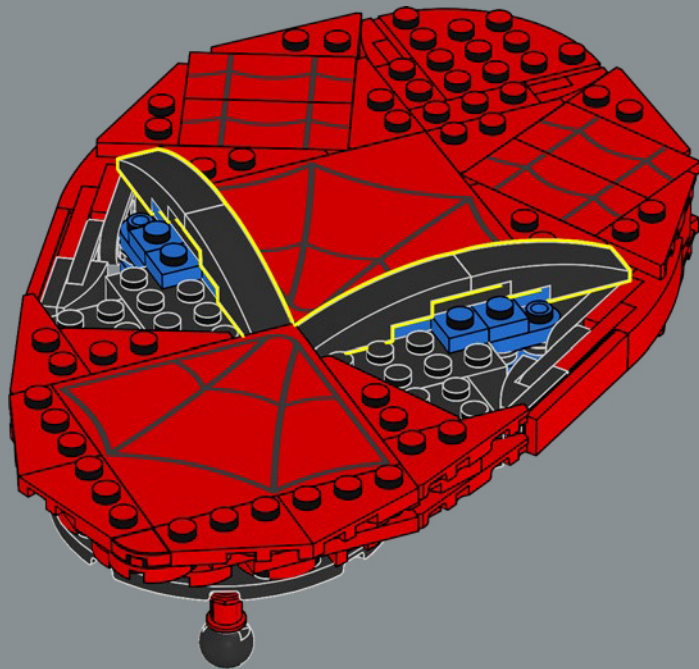

338

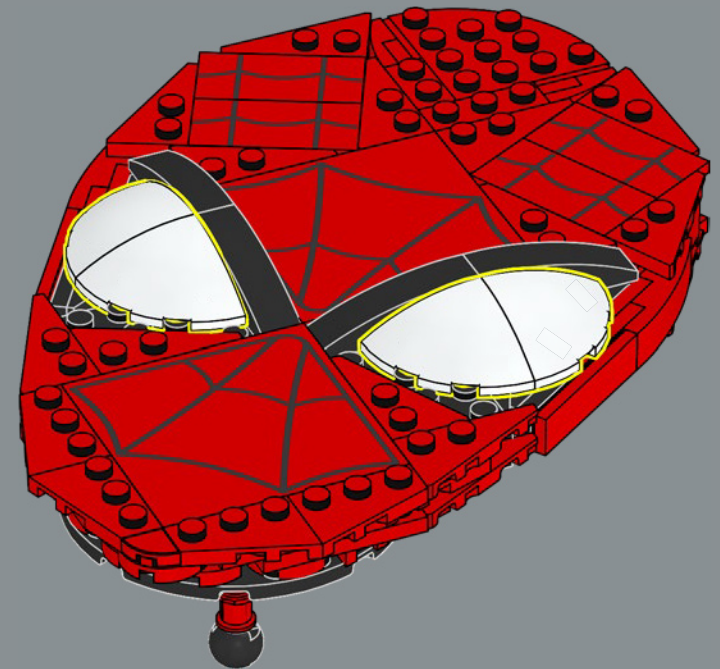

Turn Spider-Man's head **from side to side** – watch how his face **changes expressions!** The **sphere elements** create an **optical illusion** when you see the face from different angles!

Tournez la tête de Spider-Man **d'un côté à l'autre** et regardez comment son visage **change d'expression !** Les **éléments** de la sphère créent une **illusion** d'optique lorsque vous voyez le visage sous différents angles !

Gira la cabeza de Spider-Man **de lado a lado**, ¡y mira cómo **cambia la expresión** de su rostro! ¡Los **elementos esféricos** crean una **ilusión óptica** cuando ves la cara desde distintos ángulos!

339

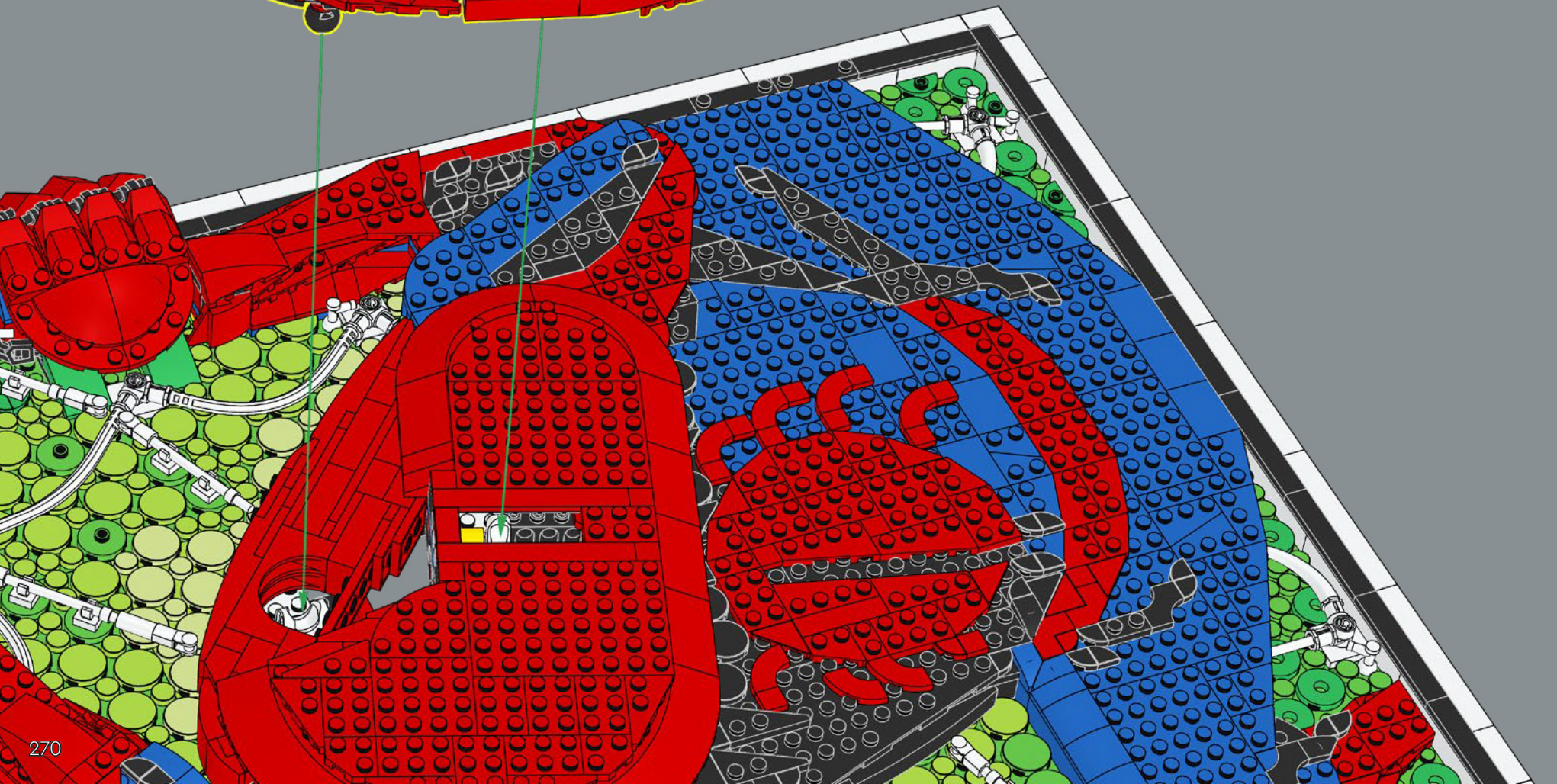
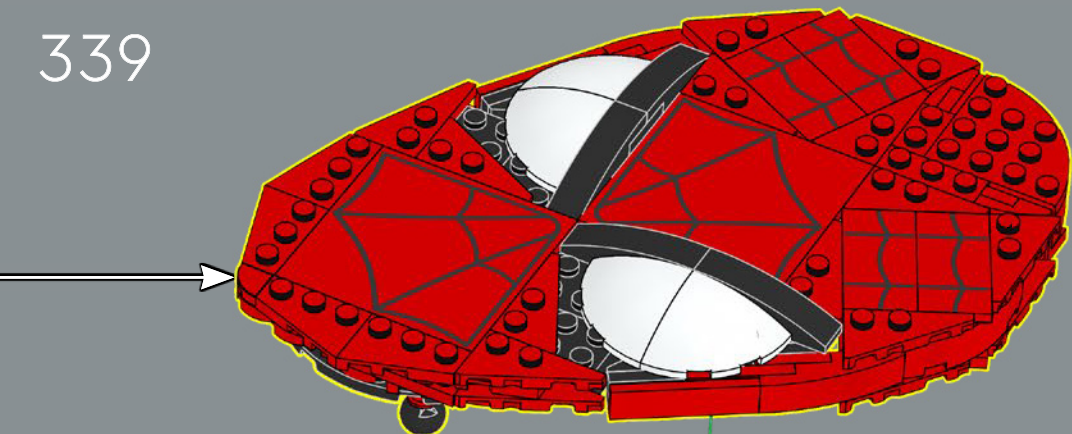



15x

340

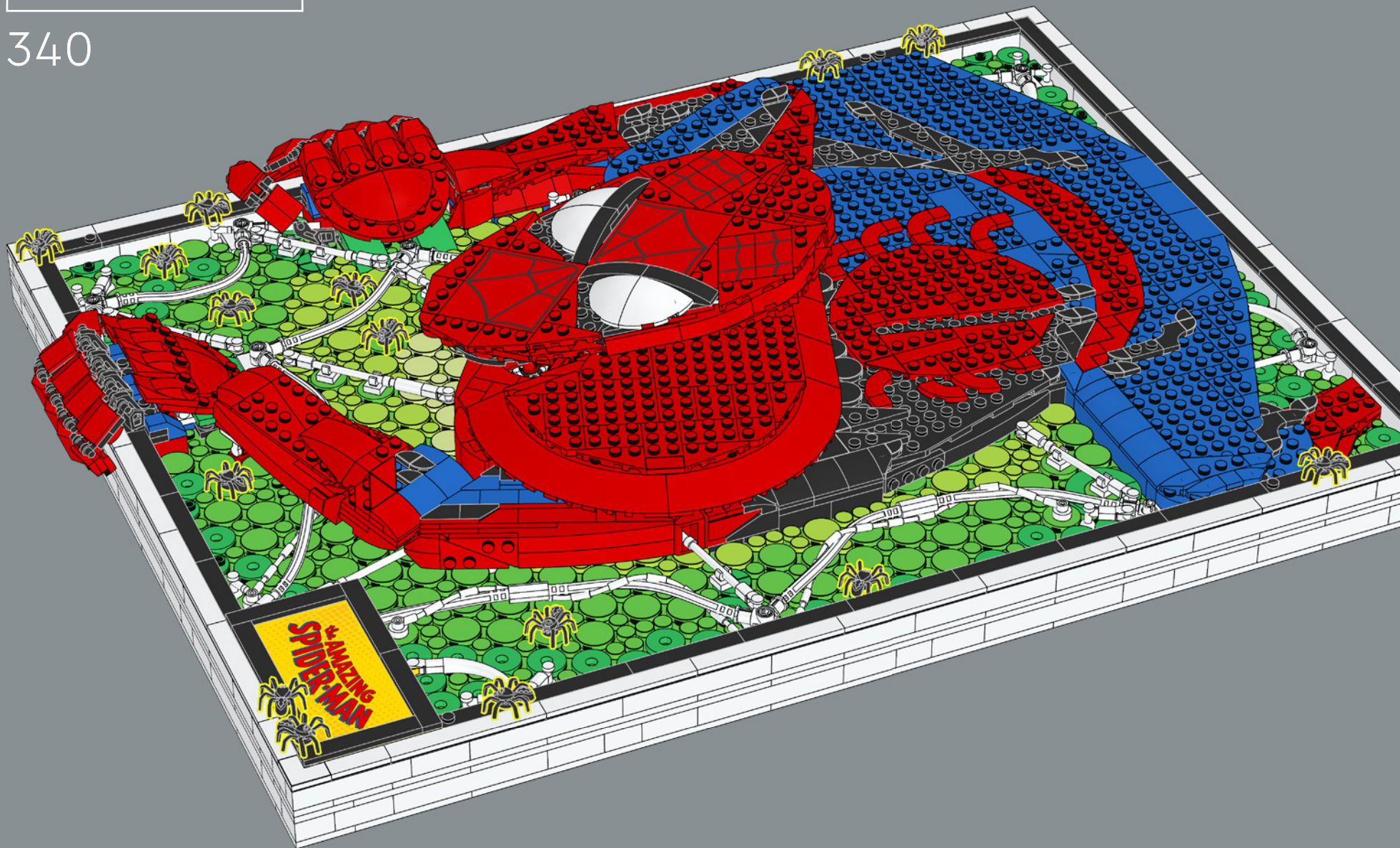

Notice the **15 spiders** in the frame? The number is an homage to the **first appearance** of Spider-Man in **AMAZING FANTASY (1962) #15**. Also, Peter Parker was **15 years old** when he gained his **powers**!

Remarquez-vous les **15 araignées** dans le cadre ? Ce numéro est un hommage à la **première apparition** de Spider-Man dans **AMAZING FANTASY (1962) #15**. De plus, Peter Parker avait **15 ans** quand il a acquis ses **pouvoirs** !

¿Te fijaste en las **15 arañas** del cuadro? El número es un homenaje a la **primera aparición** de Spider-Man en el **n.º 15 de AMAZING FANTASY (1962)**. Además, ¡Peter Parker **tenía 15 años** cuando adquirió sus **poderes**!





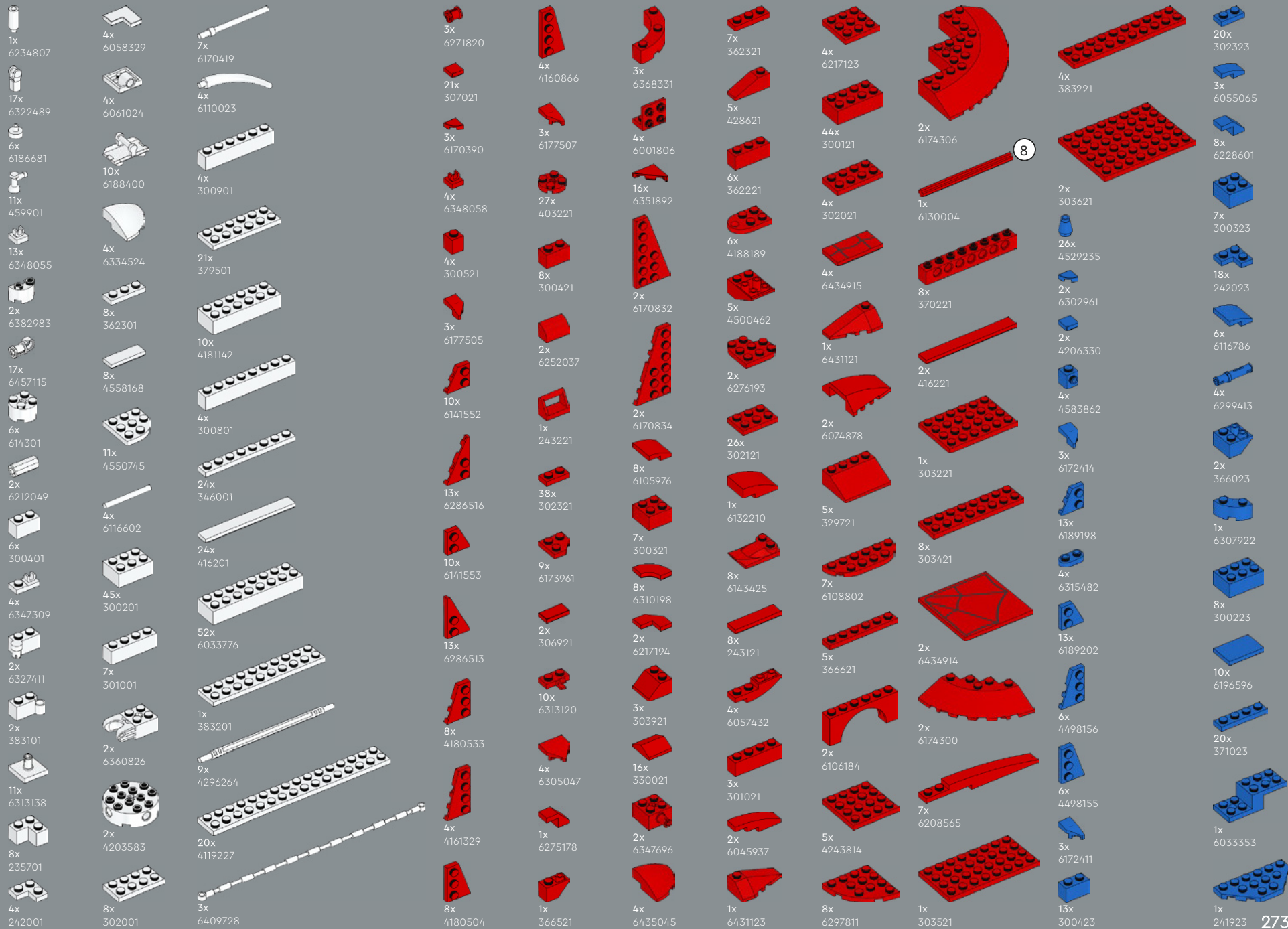

- 2x 6146306
- 5x 303223
- 3x 303423
- 7x 6037384
- 8x 303623
- 10x 4611777
- 6x 6150607
- 19x 6424859
- 42x 6074954
- 4x 6365611
- 4x 6285601
- 154x 6353793
- 71x 6422433
- 24x 6380676
- 13x 614126
- 1x 6186698
- 2x 4286267
- 31x 6172383
- 3x 6181720
- 4x 6433936
- 5x 6141554
- 3x 6295295
- 5x 6141556
- 3x 6295293
- 3x 6181713
- 9x 306926
- 9x 302326
- 2x 370026
- 10x 6261348
- 2x 6147050
- 1x 4121966
- 1x 6250020
- 14x 6214807
- 15x 6234806
- 18x 4140588
- 9x 6428168
- 1x 4283047
- 1x 4283046
- 15x 302226
- 5x 6196548
- 10x 300226
- 1x 329826
- 7x 302126
- 7x 6254045
- 1x 371026
- 2x 6039869
- 4x 6037746
- 12x 300126
- 1x 4188534
- 3x 6039347
- 1x 370626
- 33x 663626
- 6x 6070695
- 10x 6276867
- 16x 379526
- 2x 6401209
- 1x 6131571
- 5x 346026
- 2x 6456527
- 1x 6393938
- 1x 6037664
- 5x 4617860
- 4x 303626
- 14x 6279875
- 3x 6053077
- 3x 6425507
- 1x 4584274
- 1x 389426
- 2x 6101857
- 2x 6302094
- 2x 6448394
- 1x 303026
- 1x 6394881
- 1x 4143180
- 13x 428226
- 5x 6348065
- 15x 302324
- 6x 370024
- 2x 6247387
- 2x 6072627
- 1x 4558172
- 8x 371024
- 1x 301024
- 8x 4515349
- 2x 6310219
- 1x 6434916
- 27x 6284598
- 22x 6424480
- 2x 6159763
- 100x 6284583
- 42x 6092766
- 2x 6424330
- 1x 6240515
- 1x 6375710
- 2x 4494475
- 1x 6326478
- 1x 4211718
- 1x 6015349
- 4662161

5

6



LEGO.com/service



# YOU COULD WIN



## YOU COULD WIN

Your feedback will help shape the future development of this product series.

Visit:

## DU KÖNNTEST GEWINNEN

Dein Feedback trägt zur Weiterentwicklung dieser Produktreihe bei.

Geh auf:

## VOUS POURRIEZ GAGNER

Vos commentaires nous aideront à concevoir les futurs produits de cette gamme.

Visitez :

## POTRESTI VINCERE TU

La tua opinione ci aiuterà a migliorare la creazione futura di questa linea di prodotti.

Visita:

## PUEDES GANAR

Tu opinión contribuirá al futuro de esta serie de productos.

Visita:

## 轻松获奖

您的反馈将有助于我们在今后改进本产品系列。

请访问:

---

**[LEGO.com/productfeedback](https://LEGO.com/productfeedback)**

---

You also have the chance to win a LEGO® set.

Terms and conditions apply.\*

Außerdem hast du die Chance, ein LEGO® Set zu gewinnen.

Es gelten die Teilnahmebedingungen.\*

Vous pourriez également gagner un ensemble LEGO®.

Des conditions s'appliquent.\*

Hai anche la possibilità di vincere un set LEGO®.

Termini e condizioni sono applicabili.\*

También tienes la oportunidad de ganar un set LEGO®.

Aplican términos y condiciones.\*

您还有机会赢取乐高®套装。

条款和条件适用。\*

\*[LEGO.com/productfeedback-terms](https://LEGO.com/productfeedback-terms)

# *the* AMAZING SPIDER-MAN

LEGO and the LEGO logo are trademarks of the/sont des marques de commerce du/  
son marcas registradas de LEGO Group. ©2023 The LEGO Group. 6474692

© 2023 MARVEL