



Booklet available in English on
Livret disponible en français sur
Folleto disponible en español en



OUR AMAZING PLANET

● We humans have migrated, wandered and traveled across the globe in every conceivable way. Drawn to new horizons and cultures, we have crossed mountains, deserts, jungles and ice caps. We have sailed and flown across oceans in search of treasure, trade opportunities, adventure or a better life.

A tiny speck on the intergalactic map, hurtling through space, forged (roughly speaking) of stardust and nuclear waste, our planet and life on it is quite the astronomical oddity. From ancient myths to modern scientists, science fiction writers, great thinkers and explorers, we have used the sun and the night sky to navigate and map out our planet and understand our place in the universe.

Jules Verne wrote of traveling *Around the World in 80 Days* in 1873, when ships, trains and horses were the fastest means of transportation, and travel was a privilege reserved for the wealthy few. Now we can circumnavigate the world in a matter of hours. Even with the most minute details of the earth mapped out, every day brings fresh discoveries, from new paths in your own neighborhood and the changing of the seasons, to unknown species of flora or fauna.

NOTRE INCROYABLE PLANÈTE

● Nous, les humains, avons migré, erré et voyagé à travers le monde de toutes les manières imaginables. Attirés par de nouveaux horizons et de nouvelles cultures, nous avons traversé des montagnes, des déserts, des jungles et des calottes glaciaires. Nous avons traversé des océans en bateau et en avion, à la recherche de trésors, d'occasions commerciales, d'aventures ou d'une vie meilleure.

Grain minuscule sur la carte intergalactique, se déplaçant à toute allure dans l'espace, forgée (grosso modo) de poussière d'étoiles et de déchets nucléaires, notre planète et la vie qu'elle abrite constituent une véritable curiosité astronomique. Des mythes anciens aux scientifiques modernes, en passant par les auteurs de science-fiction, les grands penseurs et les explorateurs, nous

avons utilisé le soleil et le ciel nocturne pour parcourir et cartographier notre planète et comprendre notre place dans l'univers.

Jules Verne a écrit *Le tour du monde en 80 jours* en 1873, à une époque où les bateaux, les trains et les chevaux étaient les moyens de transport les plus rapides et où les voyages étaient un privilège réservé à quelques personnes fortunées. Maintenant, nous pouvons faire le tour du monde en quelques jours seulement. Même si les moindres détails de la Terre sont cartographiés, chaque jour apporte de nouvelles découvertes, qu'il s'agisse de nouveaux chemins dans votre propre quartier, du passage des saisons ou d'espèces végétales ou animales inconnues.

NUESTRO ASOMBROSO PLANETA

● Los humanos hemos migrado, deambulado y vagado por la totalidad del orbe de todas las maneras imaginables. Atraídos hacia nuevos horizontes y culturas, hemos atravesado cordilleras, desiertos, selvas y casquetes de hielo. Hemos navegado y volado encima de los océanos en busca de tesoros, oportunidades para el comercio y la aventura, o una vida mejor.

Un minúsculo grano de polvo en el mapa intergaláctico forjado a partir de polvo de estrellas y desechos nucleares, nuestro planeta y la vida que alberga constituyen una rareza a escala astronómica. Los antiguos mitos, los grandes pensadores y exploradores y los estudiosos y escritores de ciencia ficción de la era moderna confirman que hemos usado el sol y el cielo nocturno para navegar y trazar el mapa de nuestro planeta y tratar de comprender qué lugar ocupamos en el universo desde tiempos inmemoriales.

En 1873, cuando barcos, trenes y caballos eran los medios de transporte más veloces, Julio Verne escribió en su obra *La vuelta al mundo en 80 días* que viajar era un privilegio reservado para la minoría más adinerada. Ahora podemos circunnavegar el mundo en cuestión de horas. No obstante que se han hecho mapas detallados de todos los rincones de la Tierra, cada día que pasa vemos surgir grandiosos y fascinantes descubrimientos, desde nuevos senderos en nuestro vecindario y cambios en las estaciones del año hasta especies de flora y fauna desconocidas hasta entonces.



MAPPING OUT THE HISTORY OF GLOBES

● Terrestrial and celestial globes have existed for over 2,000 years. In his book *On the Heavens* from 350 BCE, Aristotle was the first to record that the earth was "a circle of no great size". He based this conclusion on his observations of the movement of the stars and planets in the night sky from different countries. The Greek mathematician Eratosthenes went on to calculate the earth's circumference within a stunningly accurate 1-10% margin of the modern polar measurement of 24,901.4 miles (40,075 km)!

Unlike a 2D map, the globe represents the placement of the oceans and landmasses without distorting proportions or distances. Globes were originally used by scientists, scholars and aristocrats to study geography, topography, bathymetry, and the earth's rotation. Parallels of latitude and meridians of longitude identified locations with extreme precision on land or at sea. Globes helped rulers, merchants, sailors, and explorers avoid peril at sea, navigate the safest routes between points of travel, or conquer new land.

Modern GPS devices are based on the exact same spherical coordinate system and used in everything from phones to space shuttles. But a classic globe will always represent our spirit of adventure and curiosity in ways no digital device can do. It is a treasured, tangible reminder of the places we love, live in, and explore.

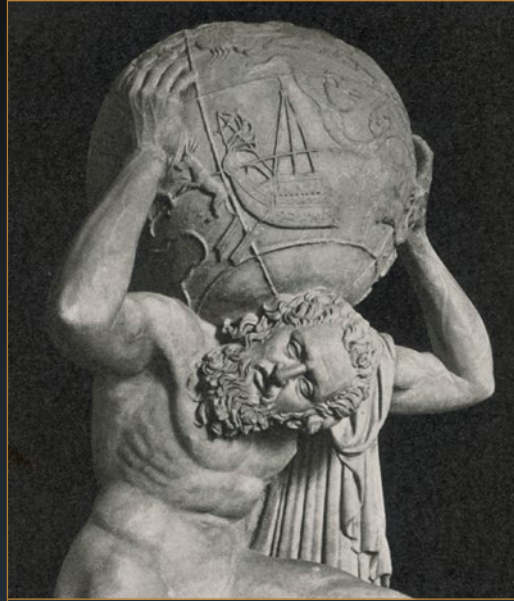

The oldest surviving celestial globe is the Farnese Atlas sculpture from 150 CE, of Atlas the Titan carrying the sky on his shoulders.

Le plus ancien globe céleste parvenu jusqu'à nous est l'Atlas Farnèse, une sculpture de 150 apr. J.-C. qui représente Atlas supportant la sphère céleste sur ses épaules.

El globo celeste más antiguo que sobrevive es el Atlas Farnesio, una escultura del año 150 a. e. c. que representa al titán Atlas cargando el cielo sobre sus hombros.

FUN FACTS FAITS AMUSANTS DATOS CURIOSOS

● The earth's total surface area is approximately 196,950,711.07 square miles (510.1 million km²), with about 71% covered by water and 29% landmass.

● This set contains 2585 LEGO® bricks. In real life, it would take 1,252,343,750 2x4 LEGO bricks lined up end to end to reach around the globe along the equator.

● The LEGO® Globe is approximately scale 1: 48,000,000.

● More than 80% of our oceans are yet to be explored but the 40,389.1 mile (65,000 kilometer) long deep sea Mid-Atlantic Ridge is hard to miss. It is the longest mountain range on earth and rises as far as 13,779.5 ft. (4,200 m) above the ocean floor.

● La surface totale de la Terre est d'environ 510,1 millions de km², dont environ 71 % sont recouverts d'eau et 29 % sont recouverts de terres émergées.

● Cet ensemble contient 2 585 briques LEGO®. Dans la vraie vie, il faudrait 1 252 343 750 briques LEGO 2x4 alignées bout à bout pour faire le tour du monde le long de l'équateur.

● Le globe terrestre LEGO® est à l'échelle 1:48 000 000.

● Plus de 80 % de nos océans doivent encore être explorés, mais la dorsale médio-atlantique, longue de 65 000 km, est immanquable. Cette chaîne de montagnes essentiellement sous-marine est la plus longue sur Terre, et elle s'élève à 4 200 m au-dessus du plancher océanique.

● La superficie total de la Tierra es de, aproximadamente, 510,1 millones de km²; cerca de un 71 % está cubierto por agua y el 29 % restante corresponde a masas de tierra.

● Este set contiene 2585 bricks LEGO®. En la vida real, se necesitarían 1.252.343.750 bricks LEGO 2x4 alineados por los extremos para dar la vuelta al mundo por el ecuador.

● La escala del Globo Terráqueo LEGO® es de, aproximadamente, 1:48.000.000.

● Aunque más de un 80 % de nuestros océanos permanece inexplorado, la dorsal mesoatlántica, con una longitud de 65.000 km, resulta difícil de pasar desapercibida. Con una elevación por encima del lecho oceánico que alcanza los 4200 m, se trata de la cordillera más larga sobre la Tierra.

TRACER L'HISTOIRE DES GLOBES

● Les globes terrestres et célestes existent depuis plus de 2 000 ans. Dans son traité *Du ciel* paru en 350 av. J.-C., Aristotele est le premier à déclarer que la Terre est « une sphère de petite taille ». Il a fondé cette conclusion sur ses observations du mouvement des étoiles et des planètes dans le ciel nocturne de différents pays. Le mathématicien grec Ératosthène a ensuite calculé la circonférence de la Terre avec une précision étonnante de 1 à 10 % de marge d'erreur par rapport à la mesure moderne de 40 075 km !

Contrairement à une carte en 2 dimensions, le globe terrestre représente l'emplacement des océans et des masses continentales sans déformer les proportions ou les distances. Les globes étaient à l'origine utilisés par les scientifiques, les érudits et les aristocrates pour étudier la géographie, la topographie, la bathymétrie et la rotation de la Terre. Les parallèles de latitude et les méridiens de longitude permettaient de repérer des lieux sur terre ou en mer avec une extrême précision. Les globes ont aidé les souverains, les marchands, les marins et les explorateurs à éviter les périls en mer, à trouver les itinéraires les plus sûrs aux différents stades d'un voyage ou à conquérir de nouvelles terres.

Les appareils GPS modernes se servent du même système de coordonnées sphériques et sont utilisés dans tout, des téléphones aux navettes spatiales. Toutefois, un globe terrestre classique représentera toujours notre sens de l'aventure et notre curiosité comme aucun appareil numérique ne peut le faire. C'est un souvenir précieux et tangible des lieux que nous aimons, dans lesquels nous vivons et que nous explorons.

HISTORIA DE LOS GLOBOS PLANETARIOS

● Los globos terráqueos y celestes han existido por más de 2000 años. En su libro *Acerca del cielo*, del año 350 a. e. c., Aristóteles fue el primero en registrar que "no solo resulta patente que [la tierra] es esférica, sino también que su tamaño no es grande". Basó esta conclusión en sus observaciones del movimiento de las estrellas y los planetas en el cielo nocturno desde distintos países. Eratóstenes, el matemático griego, fue más allá y calculó la circunferencia de la Tierra, ¡con un margen asombrosamente preciso de 1-10 % del valor calculado actual de 40.075 km a través de los polos!

A diferencia de un mapa bidimensional, el globo terráqueo representa la ubicación de mares y masas de tierra sin distorsionar distancias ni proporciones. Científicos, académicos y aristócratas fueron los primeros en usar globos terráqueos para estudiar la geografía, la topografía, la batimetría y la rotación de la Tierra. Los paralelos de latitud y meridianos de longitud identificaban los lugares con gran precisión tanto en el mar como en tierra firme. Los globos terráqueos ayudaron a gobernantes, mercaderes, marineros y exploradores a evitar riesgos en el mar, navegar por las rutas más seguras entre puntos de viaje y conquistar nuevas tierras.

Los dispositivos modernos de GPS se basan en el mismo sistema de coordenadas y se utilizan en innumerables aplicaciones, desde teléfonos celulares hasta transbordadores espaciales. Pero un globo terráqueo clásico siempre representará nuestro espíritu de aventura y curiosidad de formas que ningún aparato digital puede hacerlo. Se trata de un recordatorio tangible muy apreciado de los lugares que amamos y exploramos y de donde vivimos.

The oldest surviving terrestrial globe is the Erdapfel ("Earth apple") made by German cartographer Martin Behaim and decorated by painter and printer Georg Glockendon in 1490-1492.

Le plus ancien globe terrestre parvenu jusqu'à nous est l'Erdapfel (« pomme terrestre ») fabriqué par le cartographe allemand Martin Behaim et décoré par le peintre et imprimeur Georg Glockendon en 1490-1492.

El globo terráqueo más antiguo que se conserva es el Erdapfel (en alemán, manzana de la Tierra), hecho por el cartógrafo germano Martin Behaim y decorado por el pintor e impresor Georg Glockendon entre 1490 y 1492.

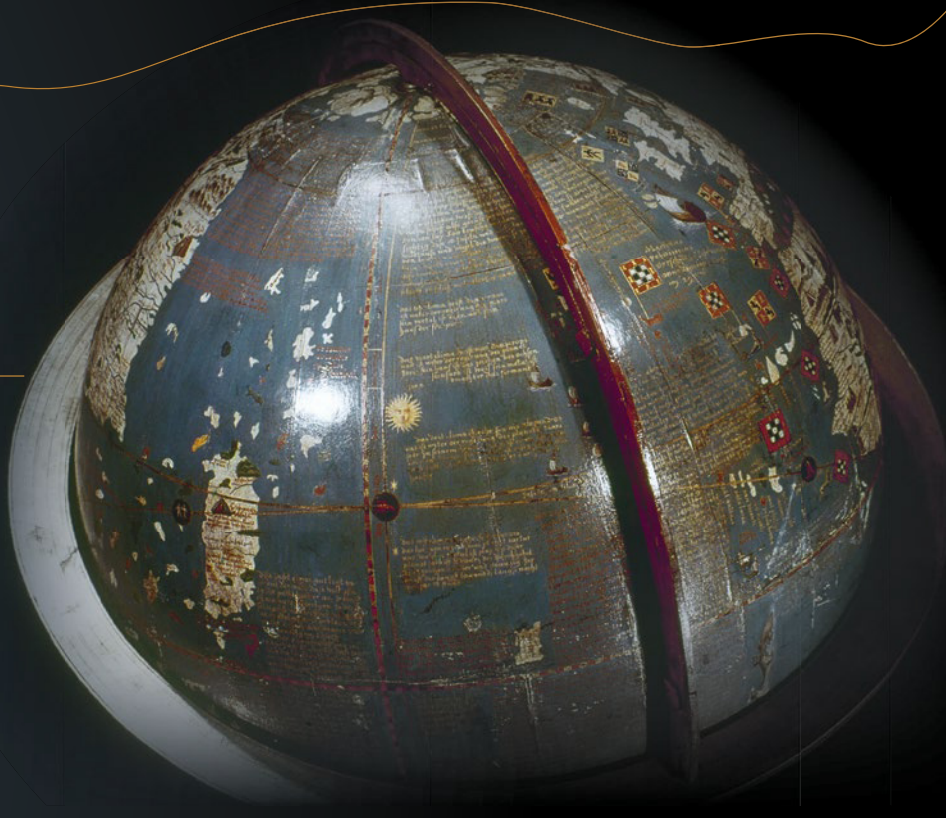



“ This globe reminds me that we are part of an utterly unique community in our own little corner of the universe. It’s a small world, after all! ”

« Ce globe terrestre me rappelle que nous faisons partie d’une communauté tout à fait unique dans notre propre petit coin de l’univers. Le monde est petit, après tout ! »

“ Este globo terráqueo me recuerda que somos parte de una comunidad indiscutiblemente singular en nuestro pequeño rincón del universo. Después de todo, ¡el mundo es muy pequeño! ”

MEET THE FAN DESIGNER

● Guillaume Roussel (LEGO® Ideas name Disneybrick55) lives in France and studies engineering. His roots in the most visited country in the world – and the home of Jules Verne – may have influenced the talented 23-year-old LEGO fan designer’s passions for architecture, design and travel. He built the Globe in just three days, including tile decorations and sticker designs.

“I’ve been a LEGO fan since I was 3 years old. For this project, I wanted to build something creative, educational and with the potential to reach as much of the world as possible. The earth is not a perfect sphere so one of my biggest challenges was shaping the continents, particularly the smaller islands in Asia and Oceania. I chose to focus on the larger islands.

My goal was to build recognizable shapes of the continents with a nostalgic vintage touch. To shape the continents, I used Google Earth gridlines to identify the positions and details. The dark blue oceans, green landmasses, white ice caps, brown pedestal and hints of pearl gold achieved the perfect vintage look.”



The first challenge for Guillaume was to create the globe shape. In the original model he used a technical structure covered by plates.

Le premier défi pour Guillaume a été de créer la forme du globe terrestre. Dans le modèle original, il a utilisé une structure technique recouverte de plaques.

Para Guillaume, el primer desafío fue crear la silueta del globo. En el modelo original, usó una estructura técnica cubierta con placas.

RENCONTRE AVEC LE CONCEPTEUR AMATEUR

● Guillaume Roussel (pseudonyme LEGO® Ideas : Disneybrick55) vit en France et étudie l'ingénierie. Ses racines dans le pays le plus visité du monde (et la patrie de Jules Verne) ont peut-être influencé les passions de ce talentueux concepteur amateur de LEGO de 23 ans pour l'architecture, la conception et les voyages. Il ne lui a fallu que trois jours pour construire le globe terrestre et concevoir les décorations des tuiles et les motifs des autocollants.

« Je suis amateur de LEGO depuis l'âge de 3 ans. Pour ce projet, je voulais construire quelque chose de créatif et d'éducatif qui saurait toucher le plus grand nombre de personnes possible. La Terre n'étant

pas une sphère parfaite, l'un de mes plus grands défis a été de façonner les continents, en particulier les petites îles d'Asie et d'Océanie. J'ai choisi de me concentrer sur les grandes îles.

Mon objectif était de construire les silhouettes caractéristiques des continents avec une touche rétro nostalgique. Pour m'aider à façonner les continents, j'ai utilisé les quadrillages de Google Earth pour établir les positions et les détails. Les océans bleu foncé, les zones terrestres vertes, les calottes glaciaires blanches, le socle brun et les touches d'or nacré ont permis d'obtenir l'apparence rétro parfaite. »

CONOCE AL FAN DISEÑADOR

● Guillaume Roussel (Disneybrick55 en LEGO® Ideas) vive en France et étudie l'ingénierie. Son origine en le país más visitado del mundo (¡y hogar de Julio Verne!) puede haber influido en la pasión que este fan diseñador de LEGO de 23 años siente por la arquitectura, el diseño y los viajes. La construcción del Globo Terráqueo, con todo y el diseño de las calcomanías y la decoración de los azulejos, le tomó solo tres días.

"He sido fan de LEGO desde que tenía 3 años. Para este proyecto, mi intención era construir algo creativo y educativo que tuviera el potencial de llegar a tantos rincones del mundo como fuera posible. Ya que la Tierra no es una esfera perfecta, uno de los desafíos más grandes que enfrenté fue dar forma a los continentes; en particular a las islas más pequeñas de Asia y Oceanía. Elegí centrarme en las más grandes.

Mi objetivo era construir continentes con siluetas que resultaran reconocibles y un toque nostálgico de estilo antiguo. Identifiqué la posición y los detalles necesarios para dar forma a los continentes utilizando las líneas de cuadrícula de Google Earth. Los océanos en azul oscuro, las masas de tierra en verde, los casquetes de hielo en blanco, el pedestal en café y los matices en dorado aperlado se combinan para crear un magnífico toque de estilo antiguo".



MEET THE LEGO® GLOBE MAKERS

● "I love sets that combine iconic objects and modern design with vintage inspiration! And this model is a reminder to respect, love and preserve our planet. I was so impressed with its design and engineering. The custom lettering and decorations link a vintage feel with the modern look of LEGO bricks, and the glow-in-the-dark tiles make the set truly unique. They remind me of vintage light-up globes that fuel our spirit of adventure!"

—Cristina Benescu,
LEGO® Graphic Designer

"I was really impressed by Guillaume's model. Everyone in the world can relate to it. It was a fun challenge to work on the structure and make the landmasses recognizable and, to a certain extent, accurate. I love to travel, and it became a great form of escapism during the 2020–21 pandemic. I would imagine sailing around the world on a sailboat while I worked on the model. I can't wait to see what creative modifications LEGO fans will make to it."

—Luka Kapeter, LEGO® Senior Designer

RENCONTREZ LES CRÉATEURS DU GLOBE TERRESTRE LEGO®

● « J'adore les ensembles qui combinent des objets emblématiques et une conception moderne avec une inspiration rétro ! Et ce modèle nous rappelle que nous devons respecter, aimer et préserver notre planète. J'ai été tellement impressionnée par sa conception et son ingénierie. Le lettrage et les décorations personnalisés confèrent un style rétro à l'aspect moderne des briques LEGO, et les tuiles phosphorescentes rendent l'ensemble vraiment unique. Elles me rappellent les anciens globes lumineux qui alimentent notre esprit d'aventure ! »

—Cristina Benescu, graphiste LEGO®

« J'ai été vraiment impressionné par le modèle de Guillaume. Il peut toucher tout le monde. C'était un défi amusant de travailler sur la structure et de rendre les masses continentales reconnaissables et, dans une certaine mesure, exactes. J'adore voyager, et c'est devenu pour moi une excellente forme d'évasion pendant la pandémie de 2020–2021. Je m'imaginai faire le tour du monde sur un voilier pendant que je travaillais sur le modèle. J'ai hâte de voir les modifications créatives que les amateurs de LEGO y apporteront. »

—Luka Kapeter,
concepteur principal LEGO®

CONOCE A LOS CREADORES DEL GLOBO TERRÁQUEO LEGO®

● "¡Me encantan los sets que combinan objetos icónicos y diseños modernos con inspiración de estilo antiguo! Este modelo es un recordatorio de que debemos respetar, amar y preservar nuestro planeta. Quedé impresionada con su diseño e ingeniería. Las inscripciones y decoraciones personalizadas aportan un toque clásico al aspecto moderno de los bricks LEGO, y los azulejos que brillan en la oscuridad convierten el set en una pieza verdaderamente única. ¡Me recuerdan los globos antiguos con luz que alimentan nuestro espíritu de aventura!"

—Cristina Benescu,
diseñadora gráfica de LEGO®

"El modelo de Guillaume me dejó impresionado. Es un objeto que todo el mundo conoce. Trabajar en la estructura y hacer que las masas de tierra fueran reconocibles y, hasta cierto punto, precisas, fue un desafío muy divertido. Me encanta viajar, y eso me dio la oportunidad de tomar distancia del estrés provocado por la pandemia de 2020–2021. Me imaginaba navegando por el mundo en un bote de vela mientras trabajaba en el modelo. Estoy impaciente por ver las creativas modificaciones que los fans de LEGO le harán."

—Luka Kapeter,
diseñador sénior de LEGO®



COMBINING TWO LEGO® WORLDS

● Fan designer Guillaume Roussel and LEGO® Senior Designer Luka Kapeter combined the best of two LEGO worlds when they built the Globe and stand. They used advanced building techniques and integrated LEGO System bricks (with studs and tubes) and LEGO Technic® elements (with beams, pins, axles and connectors) to keep the model lightweight yet sturdy. The result is a seamlessly integrated art piece and a truly immersive building experience.

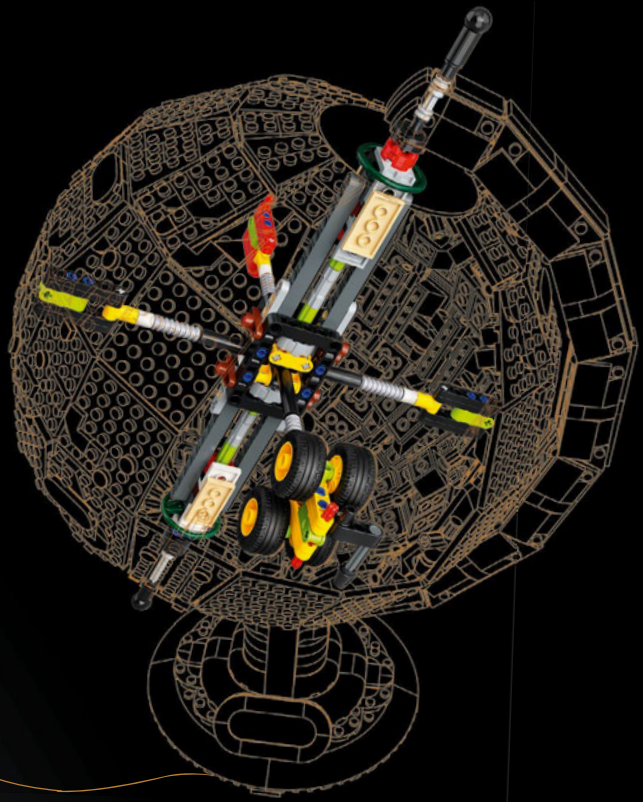

COMBINER DEUX MONDES LEGO®

● Le concepteur amateur Guillaume Roussel et le concepteur principal LEGO® Luka Kapeter ont combiné le meilleur de deux mondes LEGO lorsqu'ils ont construit le globe terrestre et son support. Ils ont utilisé des techniques de construction avancées et ont intégré des briques du système LEGO (avec des tenons et des tubes) et des éléments LEGO Technic™ (avec des poutres, des tiges, des essieux et des connecteurs) pour que le modèle soit léger, mais solide. Le résultat est une œuvre d'art parfaitement intégrée et une expérience de construction des plus immersives.

LA COMBINACIÓN DE DOS MUNDOS LEGO®

● El fan diseñador Guillaume Roussel y el diseñador sénior de LEGO® Luka Kapeter combinaron lo mejor de dos mundos LEGO al construir el Globo Terráqueo y su soporte. Utilizaron técnicas avanzadas de construcción e incorporaron bricks LEGO System (con espigas y tubos) y elementos LEGO Technic™ (con vigas, pernos, ejes y conectores) para lograr que el modelo fuera a la vez ligero y sólido. El resultado es una pieza de arte perfectamente integrada y una experiencia de construcción totalmente envolvente.



TIP: The easiest way to lift or move your Globe is by holding one hand under the stand and the other on top or on the side.



ASTUCE : La façon la plus simple de soulever ou de déplacer votre globe terrestre est de placer une main sous le support et l'autre sur le dessus ou sur le côté du globe.



CONSEJO: La forma más sencilla de levantar tu Globo Terráqueo es colocando una mano por debajo del soporte y la otra en la parte superior o por un lado.



TOGETHER, WE CAN REBUILD THE WORLD

● As we worked with Guillaume Roussel to build a perfect Globe, it was only natural for us to wonder, what IS a perfect Earth? What will our kids and future explorers discover about our planet, 10, 100, 1000 years from now? How can we leave a positive impact on the planet and help build a safe world for future generations? At the LEGO Group, sustainability is a natural part of the goals we set. We work with partners, research institutions, and families all over the world to find new creative ways to make a difference.

We are exploring solutions for the LEGO Group that will have a positive impact on the planet our children will inherit. Sustainability is vital to how we live, play and work together.

Visit LEGO.com/Sustainability to learn more about our Planet Promise.
Visitez LEGO.com/Sustainability pour en savoir plus sur notre promesse envers la planète.
Visita LEGO.com/Sustainability para conocer más detalles sobre nuestra Promesa al Planeta.



ENSEMBLE, NOUS POUVONS RECONSTRUIRE LE MONDE

● En travaillant avec Guillaume Roussel pour construire un globe terrestre parfait, nous nous sommes naturellement demandé, qu'est-ce qu'une Terre parfaite ? Que découvriront nos enfants et les futurs explorateurs à propos de notre planète dans 10, 100 ou 1 000 ans ? Comment pouvons-nous avoir un impact positif sur la planète et contribuer à construire un monde sûr pour les générations futures ? Au sein du Groupe LEGO, la durabilité fait naturellement partie de nos objectifs. Nous travaillons avec des partenaires, des instituts de recherche et des familles du monde entier pour trouver de nouveaux moyens créatifs de changer les choses. Nous explorons des solutions pour le Groupe LEGO qui auront un impact positif sur la planète dont nos enfants hériteront. La durabilité est essentielle à la façon dont nous vivons, jouons et travaillons ensemble.

JUNTOS, PODEMOS RECONSTRUIR EL MUNDO

● Trabajar de la mano de Guillaume Roussel para construir el globo terráqueo perfecto nos hizo plantearnos las siguientes preguntas: ¿Cómo SERÍA una Tierra perfecta? ¿Qué cosas descubrirán nuestros descendientes y los futuros exploradores acerca de la Tierra dentro de 10, 100 o 1000 años? ¿Cómo podemos hacer que nuestro impacto para el planeta sea positivo y contribuir a la construcción de un mundo más seguro para las generaciones futuras? En The LEGO Group, la sustentabilidad es una parte natural de las metas que nos fijamos. Trabajamos con distintos socios, instituciones de investigación y familias de todo el mundo para encontrar nuevas y creativas formas de marcar una diferencia. Estamos explorando soluciones que nos permitan garantizar que el impacto de The LEGO Group sea positivo para el planeta que nuestros hijos heredarán. La sustentabilidad es un componente vital de la forma en que vivimos, jugamos y trabajamos juntos.



WE ARE COMMITTED TO PROTECTING THE ENVIRONMENT

We are working on reducing our climate impact and using more renewable energy. We are innovating the materials we use in our LEGO® products and packaging, and we're finding ways to keep LEGO bricks in play.

WE BELIEVE IN THE POWER OF PLAY

When children play, they can build valuable life skills while having fun. Learning through play enables children to solve problems creatively, boosting confidence and resilience. Every child should have the opportunity to achieve their full potential.

WE THINK EVERYONE IS AWESOME

LEGO play is for everyone, no matter your race, gender, how you identify or who you love. We care deeply about children's development, and one of our goals is to promote family-friendly workplaces across our supply chain.

NOUS NOUS ENGAGEONS À PROTÉGER L'ENVIRONNEMENT

Nous nous efforçons de réduire notre impact sur le climat et d'utiliser davantage d'énergies renouvelables. Nous innovons dans les matériaux que nous utilisons pour fabriquer nos produits et emballages LEGO®, et nous trouvons des moyens de garder les briques LEGO actives.

NOUS CROYONS AU POUVOIR DU JEU

Lorsqu'ils jouent, les enfants peuvent acquérir de précieuses compétences tout en s'amusant. L'apprentissage par le jeu permet aux enfants de résoudre des problèmes de manière créative, ce qui renforce la confiance et la résilience. Chaque enfant doit avoir la possibilité de réaliser son plein potentiel.

TOUT LE MONDE EST GÉNIAL

Le jeu LEGO est pour tout le monde, peu importe votre race, votre genre, comment vous vous identifiez ou qui vous aimez. Le développement des enfants nous tient à cœur, et l'un de nos objectifs est de promouvoir des lieux de travail favorables aux familles dans l'ensemble de notre chaîne d'approvisionnement.

ESTAMOS COMPROMETIDOS A PROTEGER EL MEDIO AMBIENTE

Nos esforzamos por reducir nuestro impacto climático y usar más energía renovable. Innovamos en los materiales que utilizamos en nuestros empaques y productos LEGO® y buscamos nuevas formas de hacer que los bricks LEGO se usen para jugar tanto como sea posible.

CREEMOS EN EL PODER DEL JUEGO

Cuando los niños juegan, desarrollan habilidades valiosas para la vida al tiempo que se divierten. Aprender mediante el juego permite que los niños resuelvan problemas utilizando su creatividad, reforzando su confianza y resiliencia. Todos los niños deberían tener la oportunidad de alcanzar su máximo potencial.

CREEMOS QUE TODO EL MUNDO ES INCREÍBLE

El juego con LEGO es para todo el mundo, independientemente de su raza, su género, cómo se identifique o a quién ame. El desarrollo de los niños es una prioridad para nosotros. Por eso, uno de nuestros objetivos es fomentar que se promuevan las relaciones familiares en el lugar de trabajo en toda nuestra cadena de suministro.

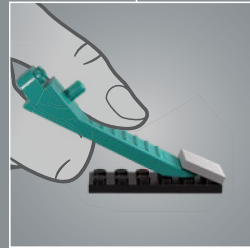
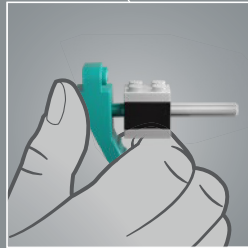
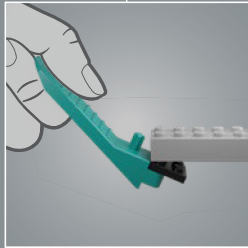
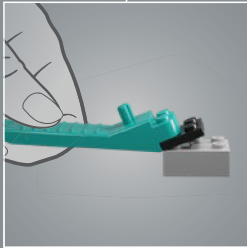
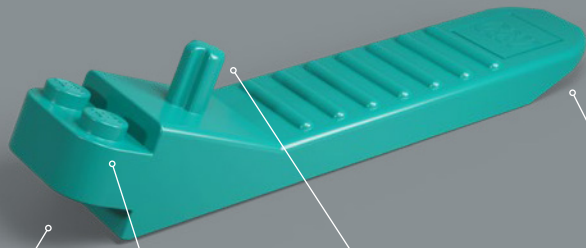

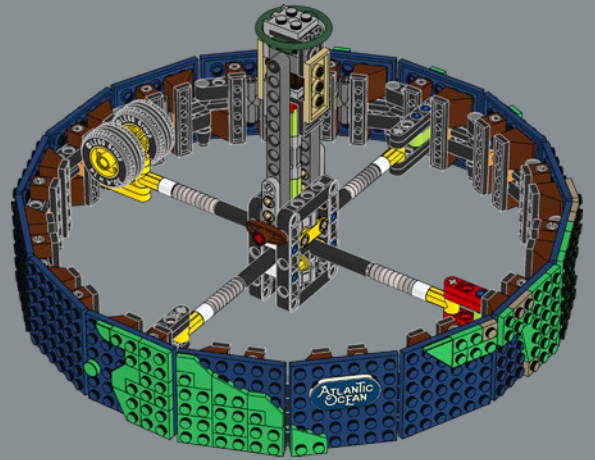
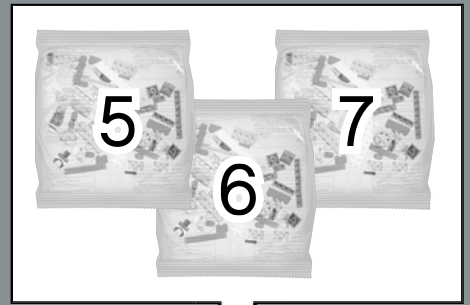
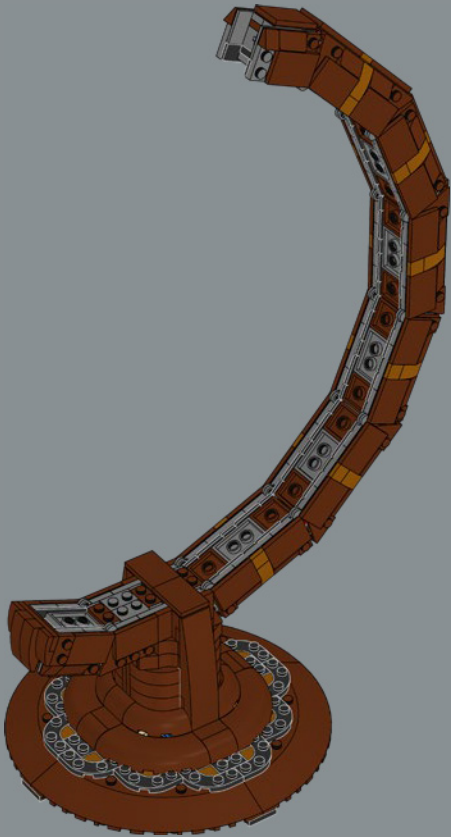
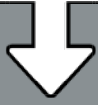
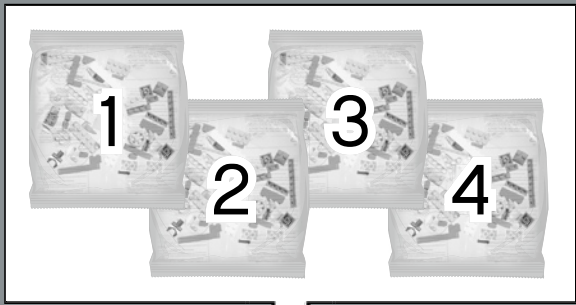

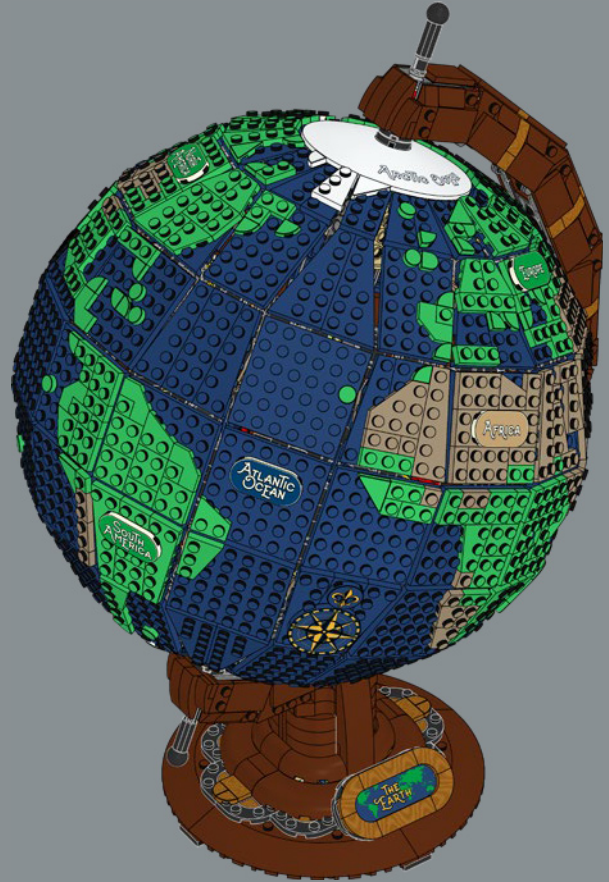
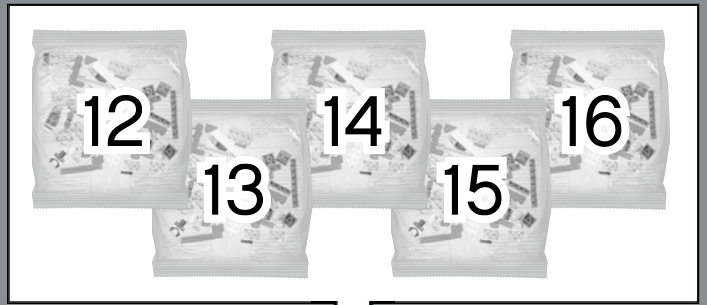
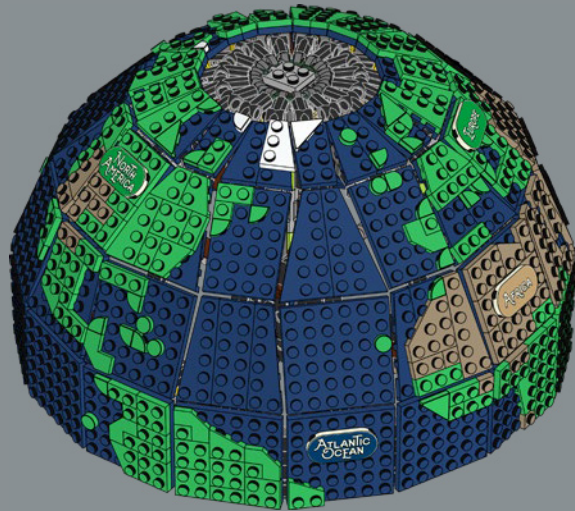
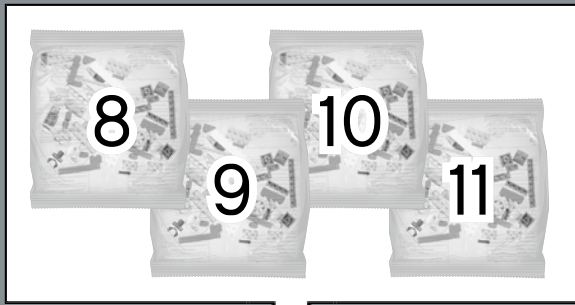

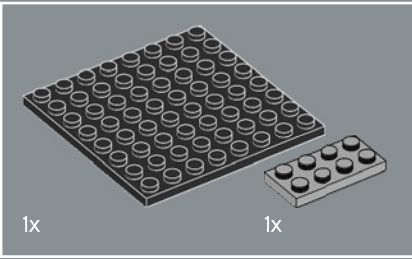
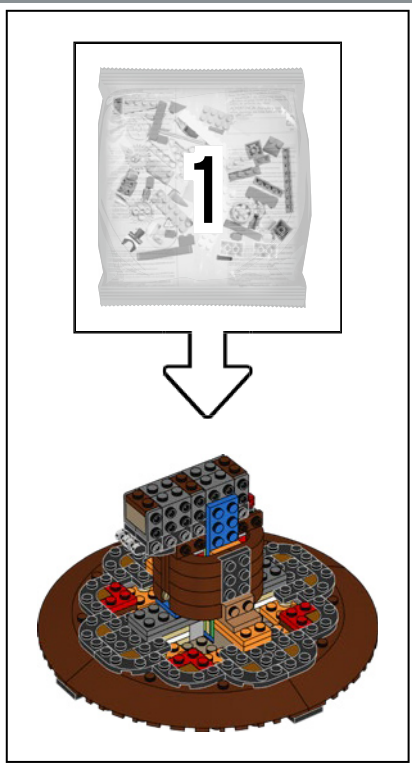

1

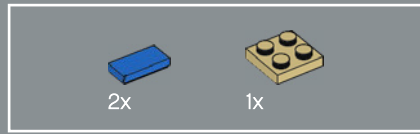
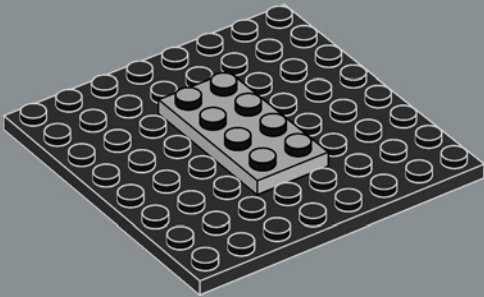

2

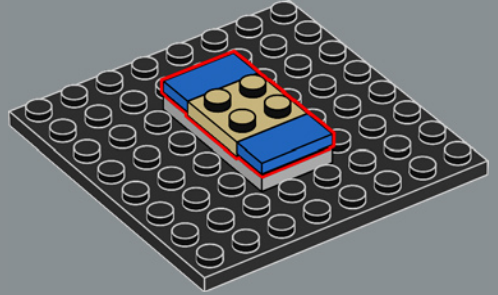

3

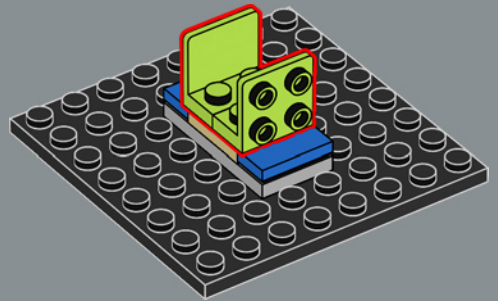

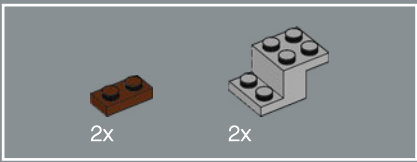

4

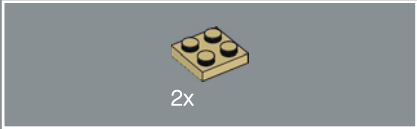
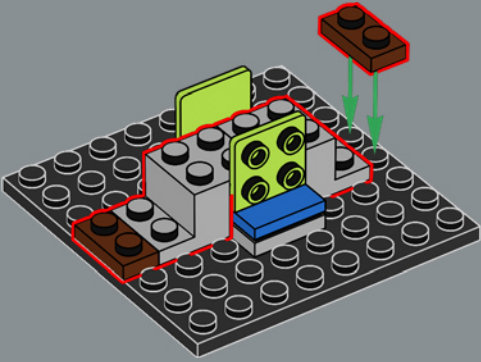

5

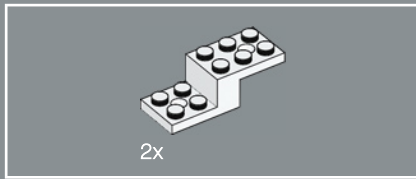
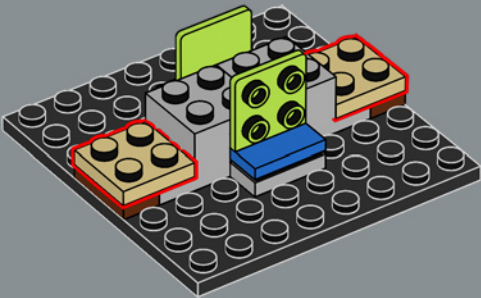

6

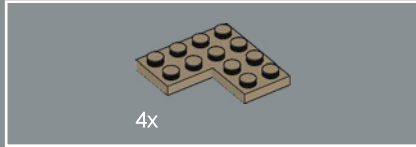
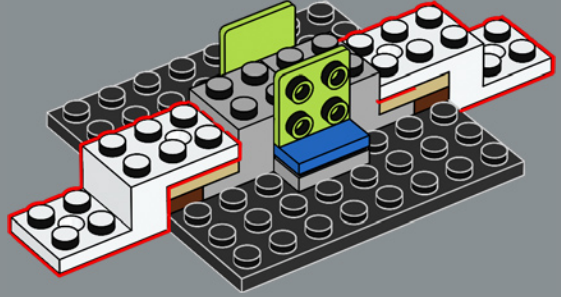

7

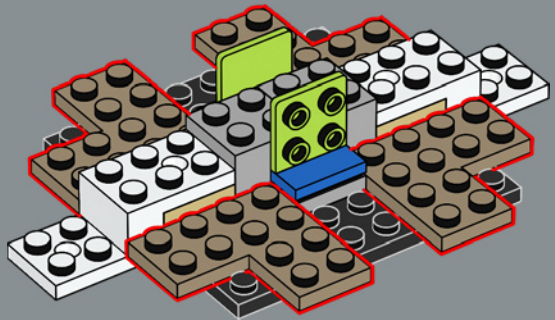

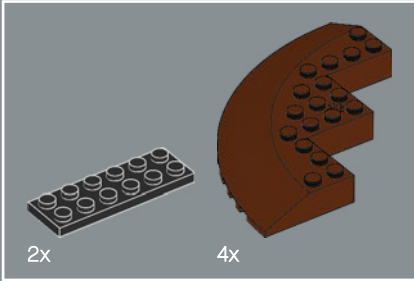
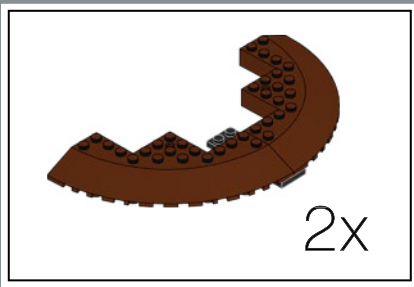

1

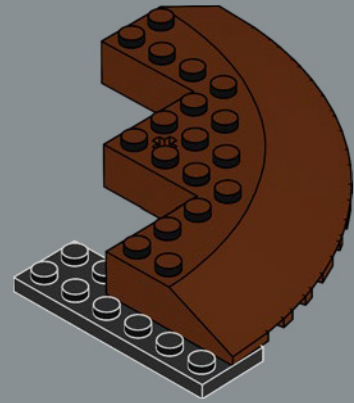

2

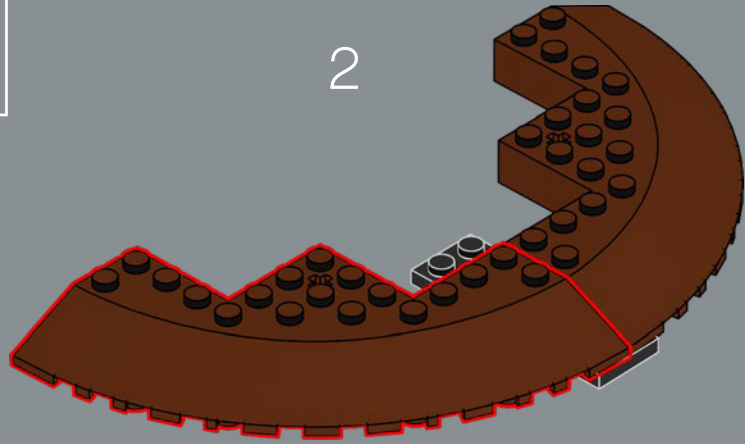

2x

8

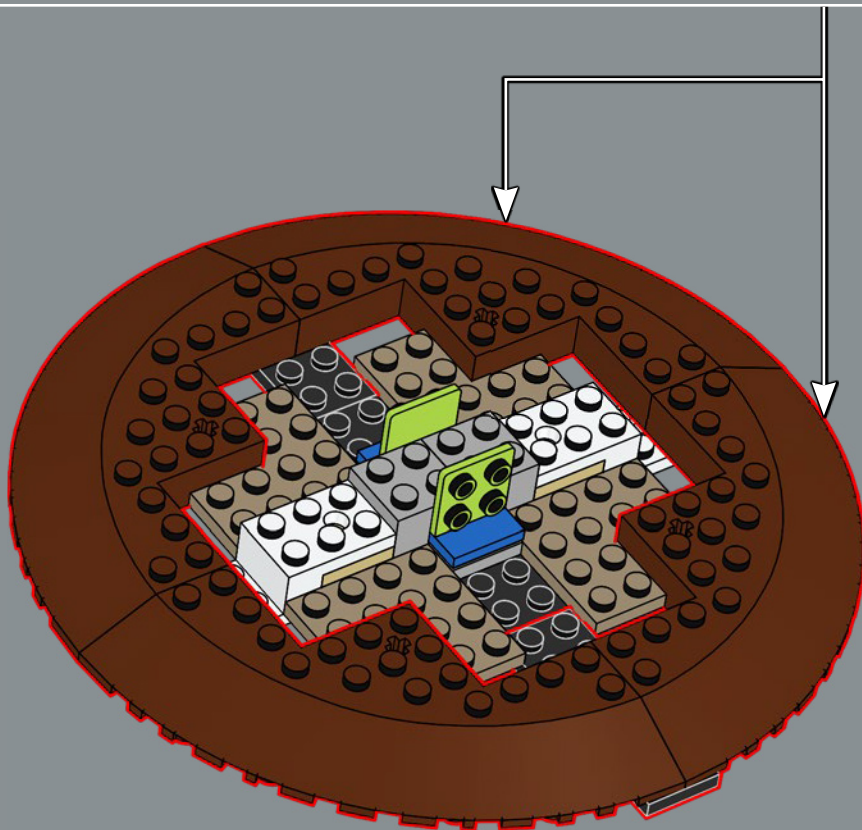

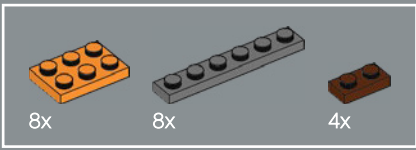

9

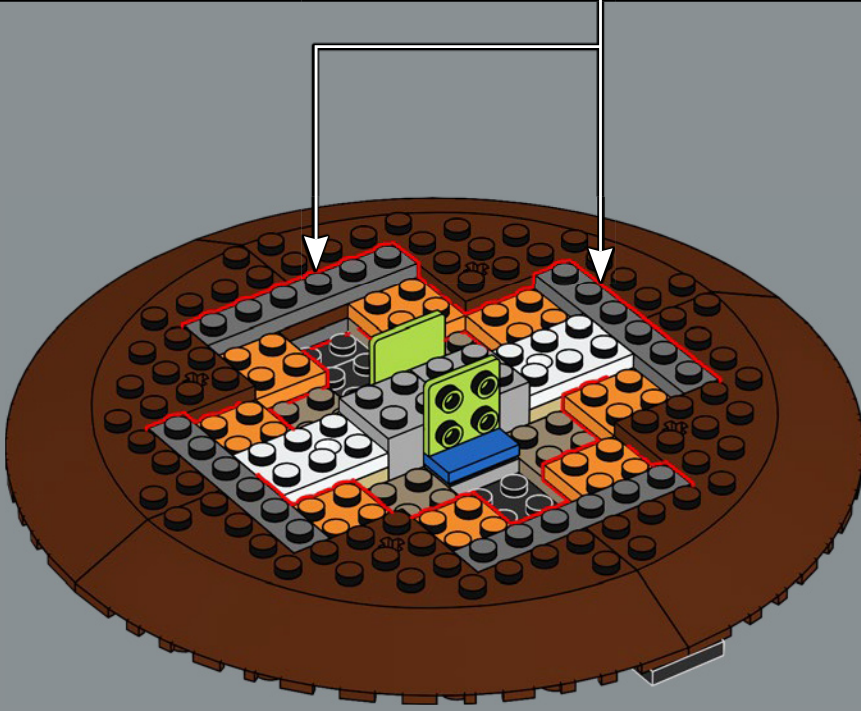
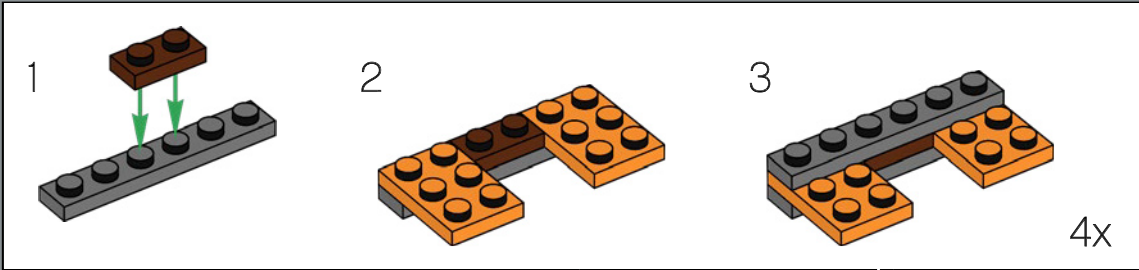

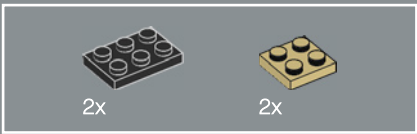

10

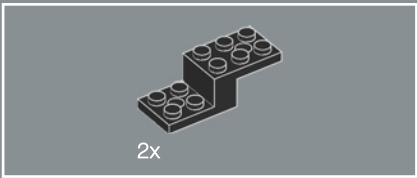
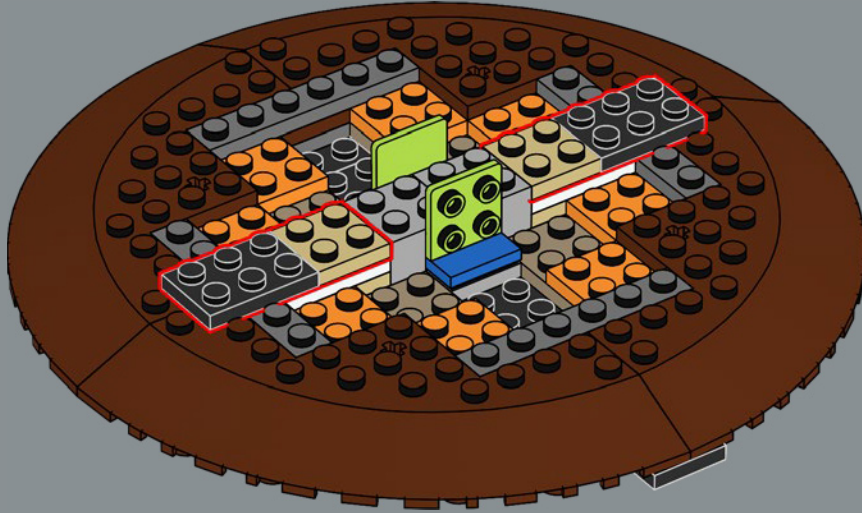

11

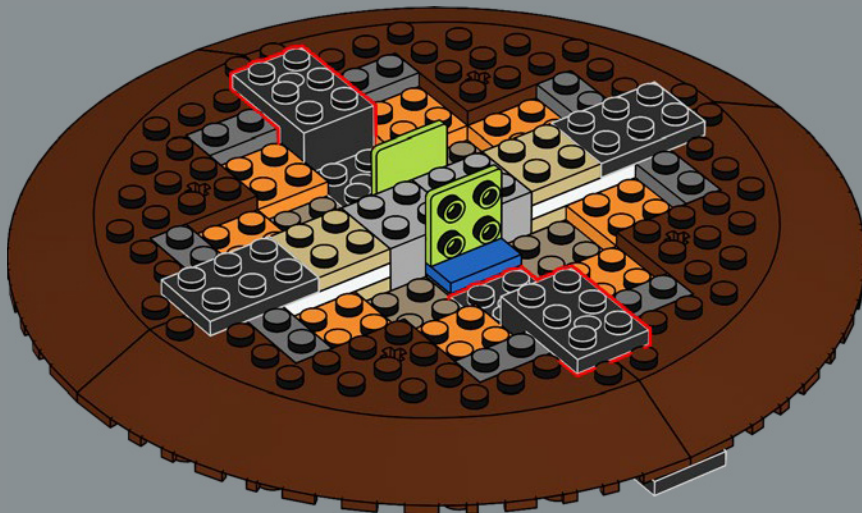

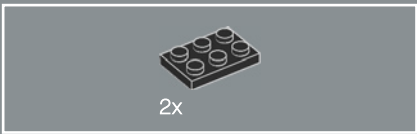

12

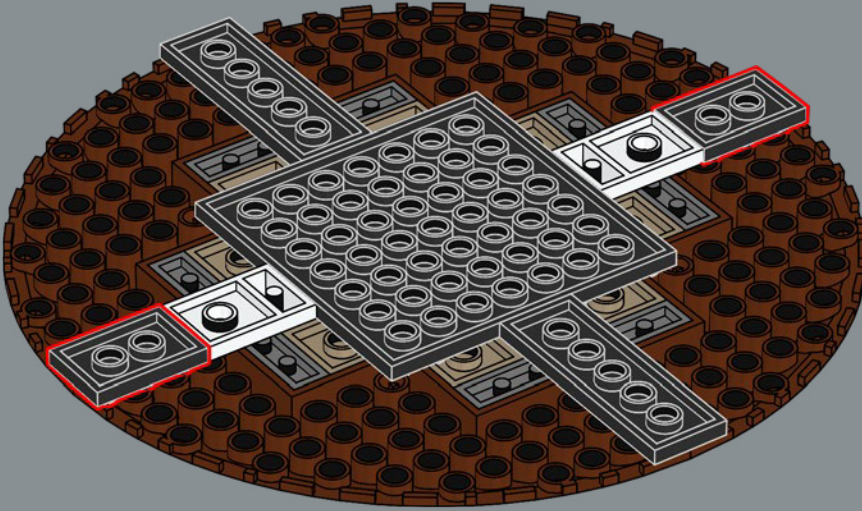

13

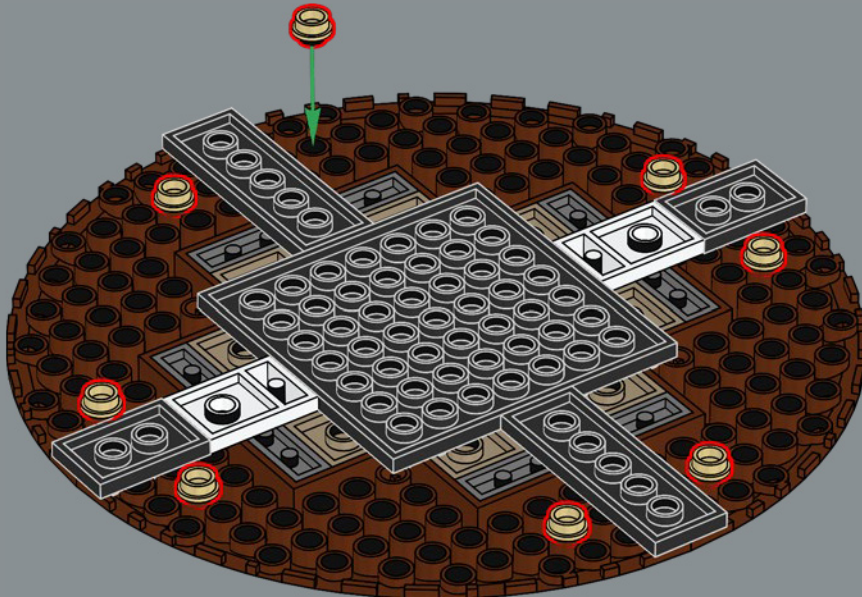

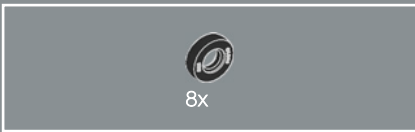

14

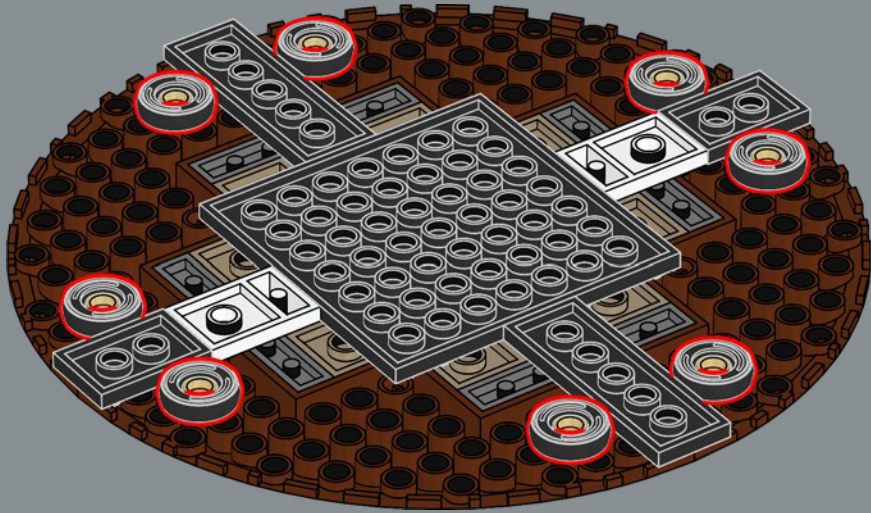

15

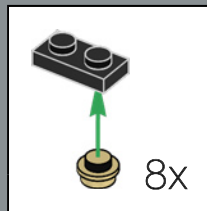

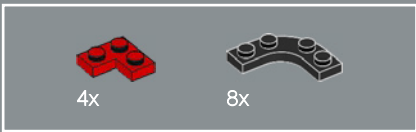

16

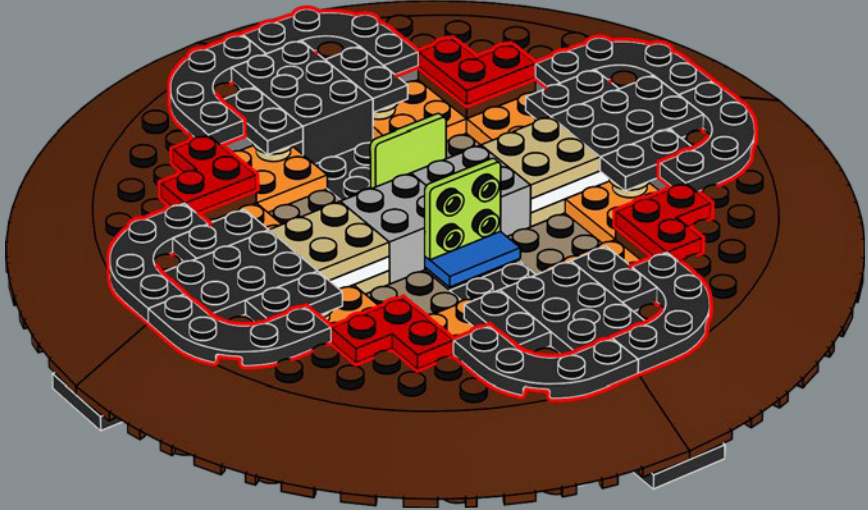

17

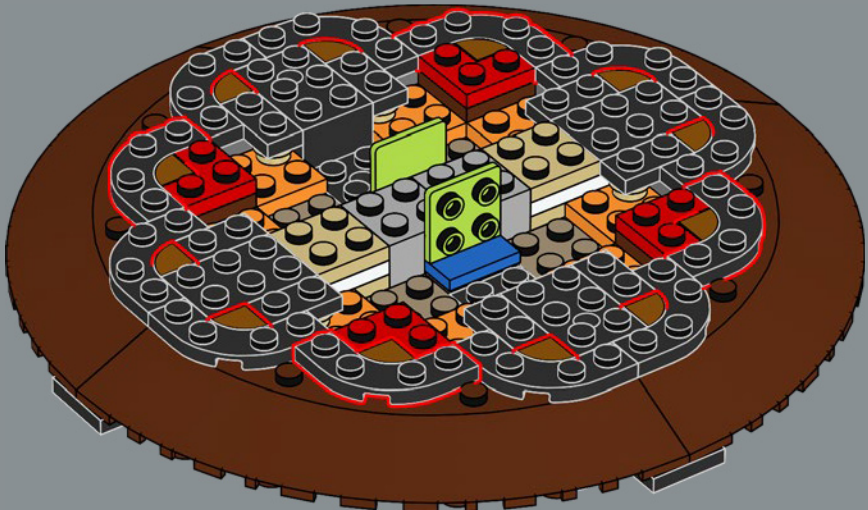

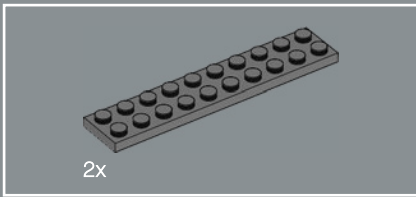

18

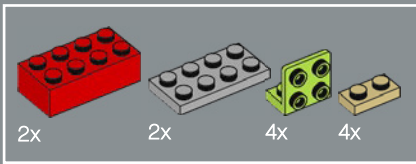
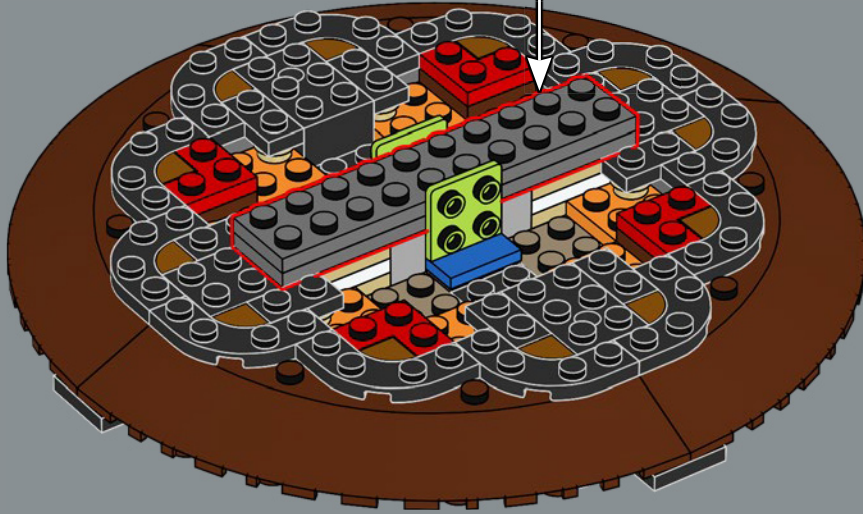
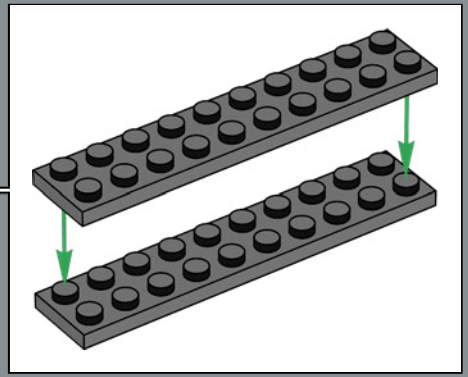

19

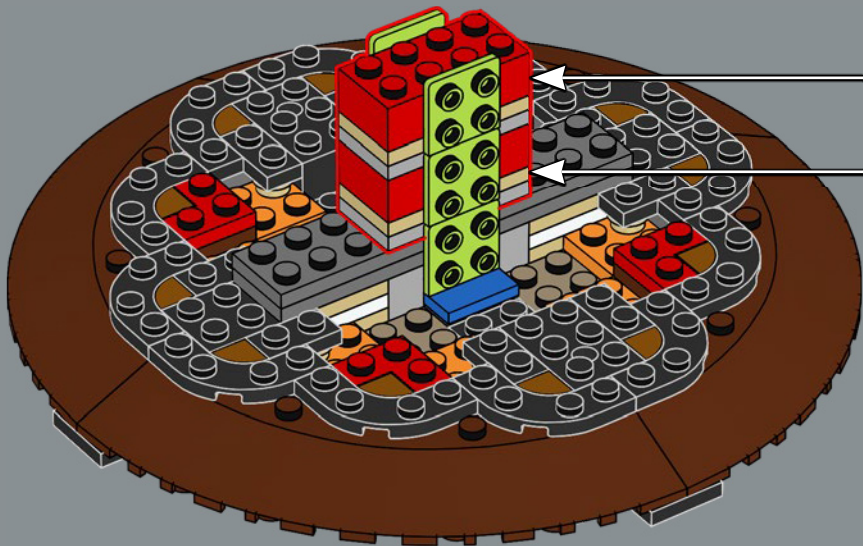
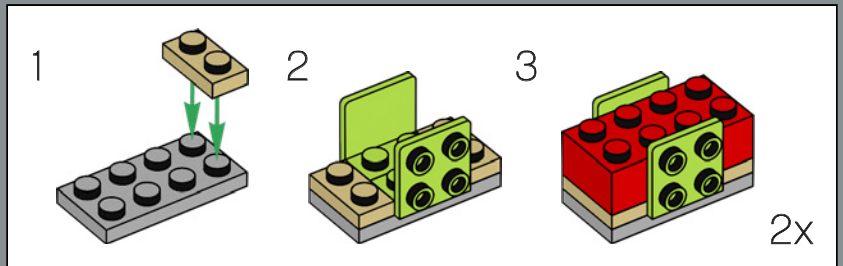

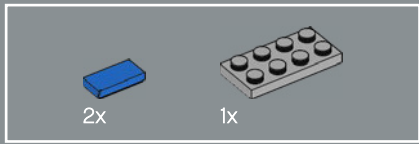

20

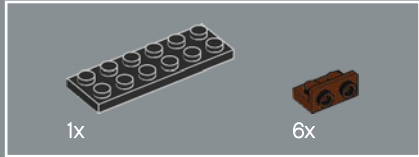
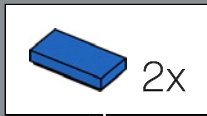

21

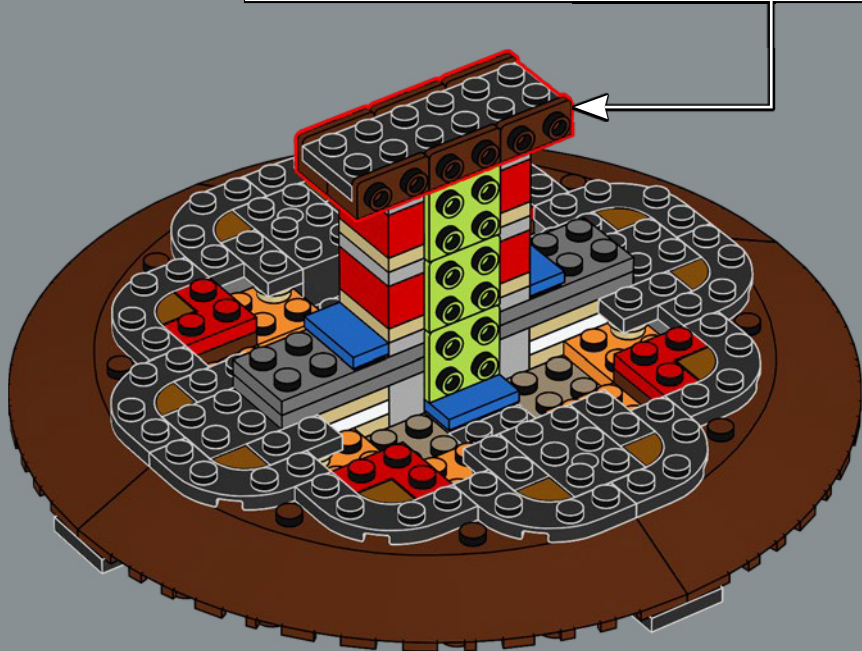
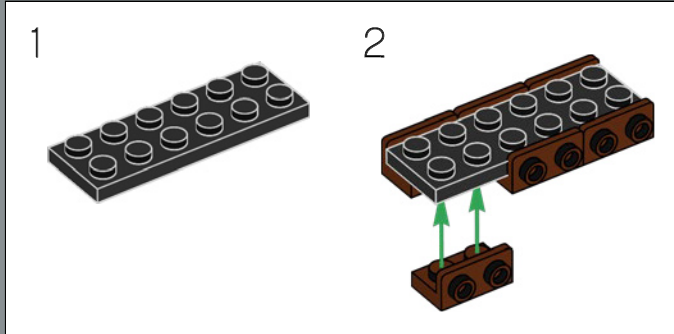

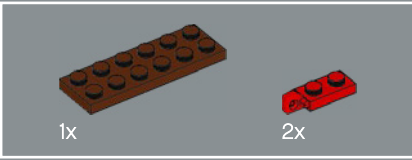
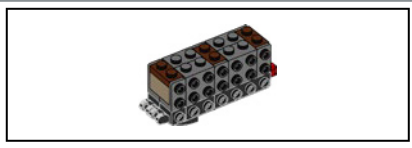

22

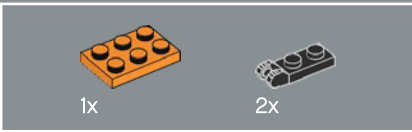
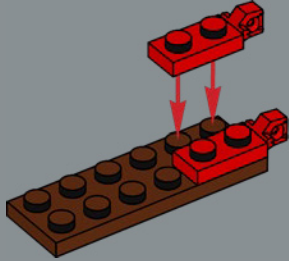

23

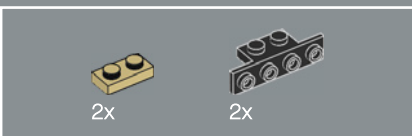
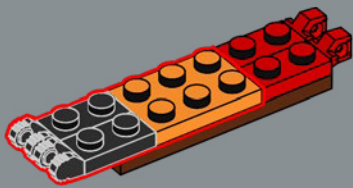

24

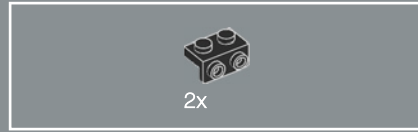
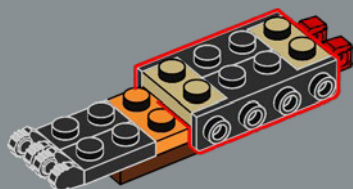

25

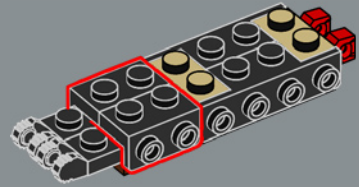

26

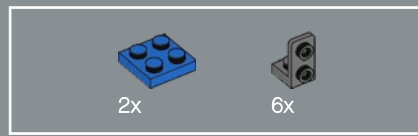
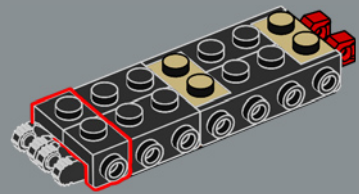

27

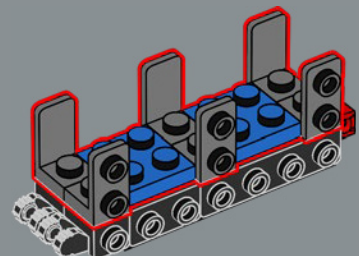

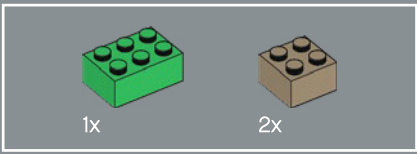

28

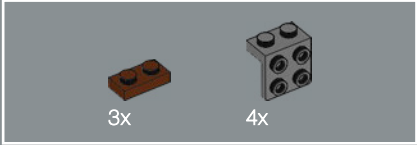
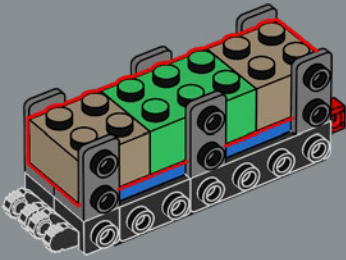

29

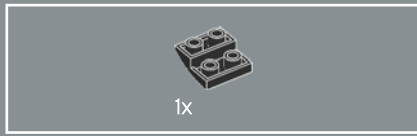
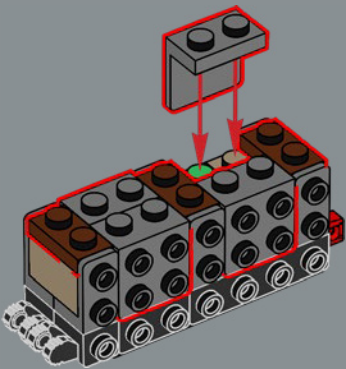

30

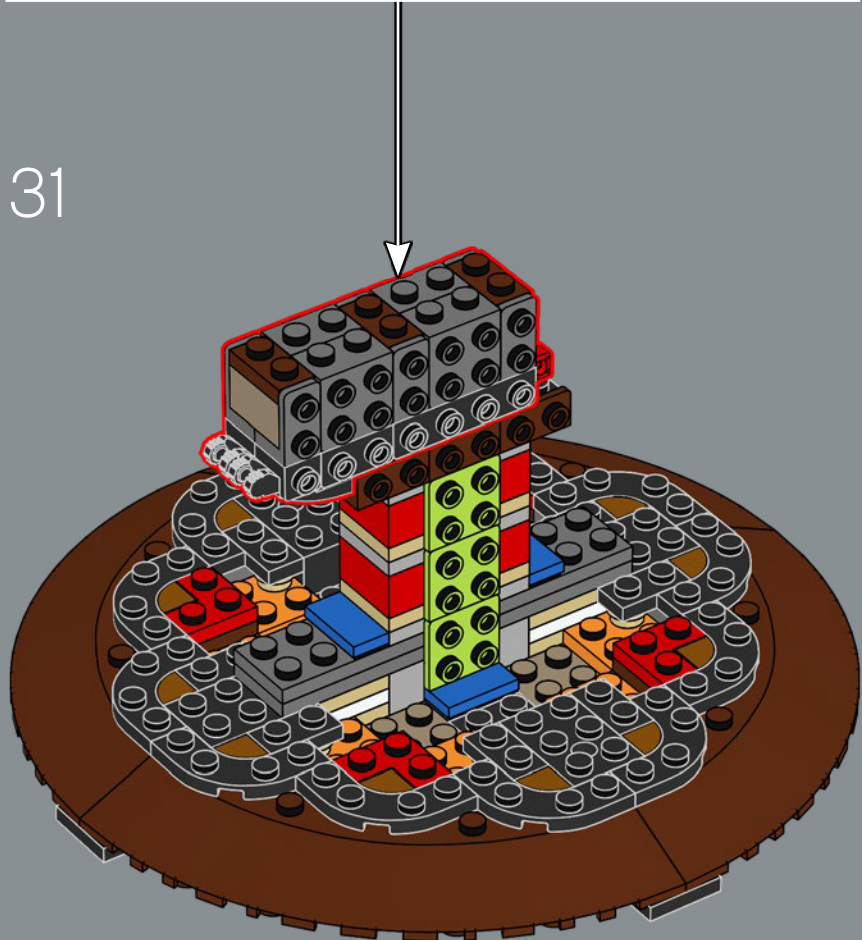
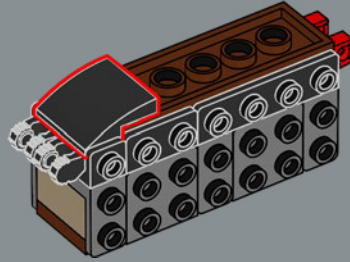

31

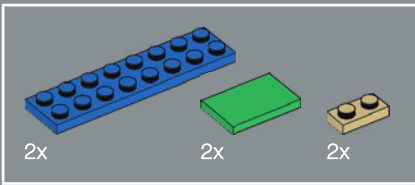

32

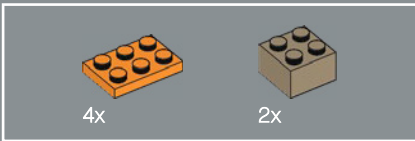
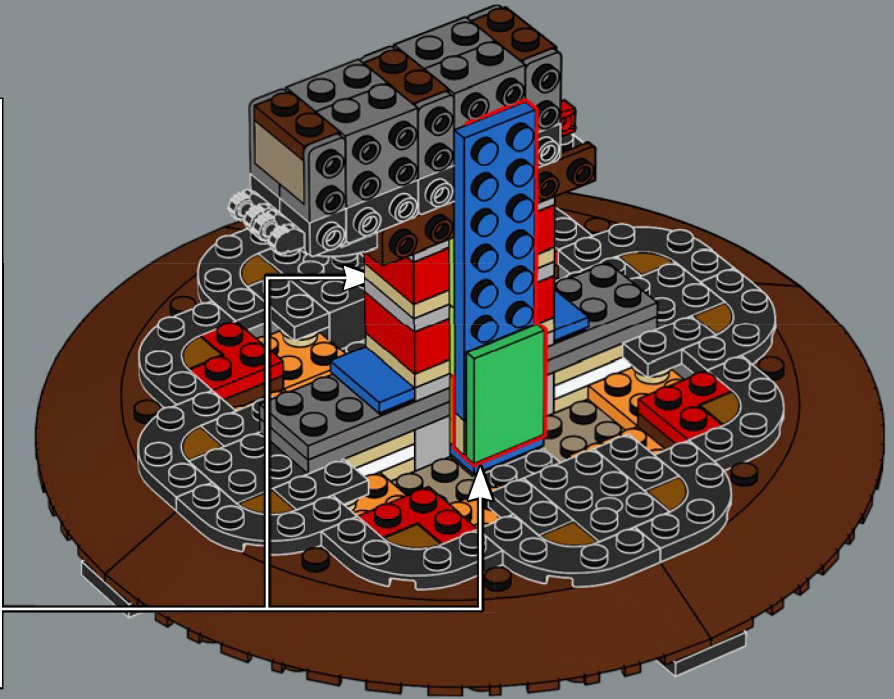
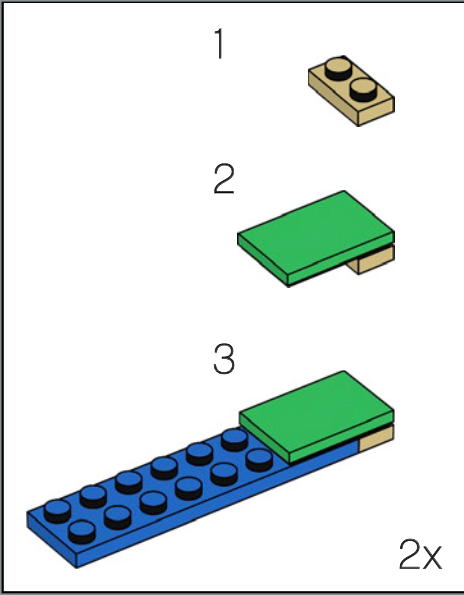

33

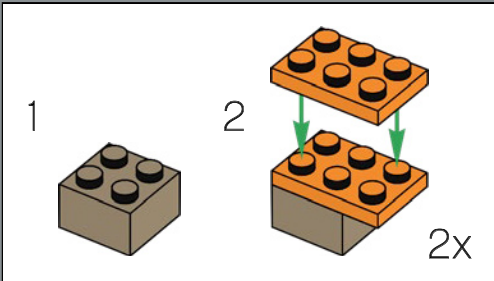

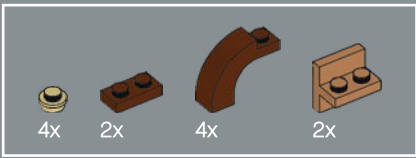

34

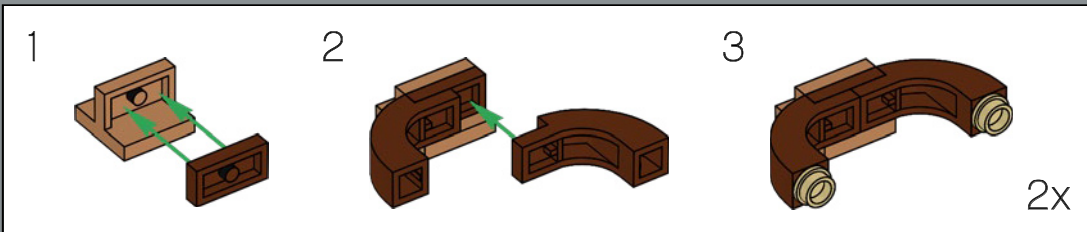

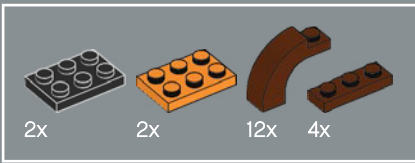

35

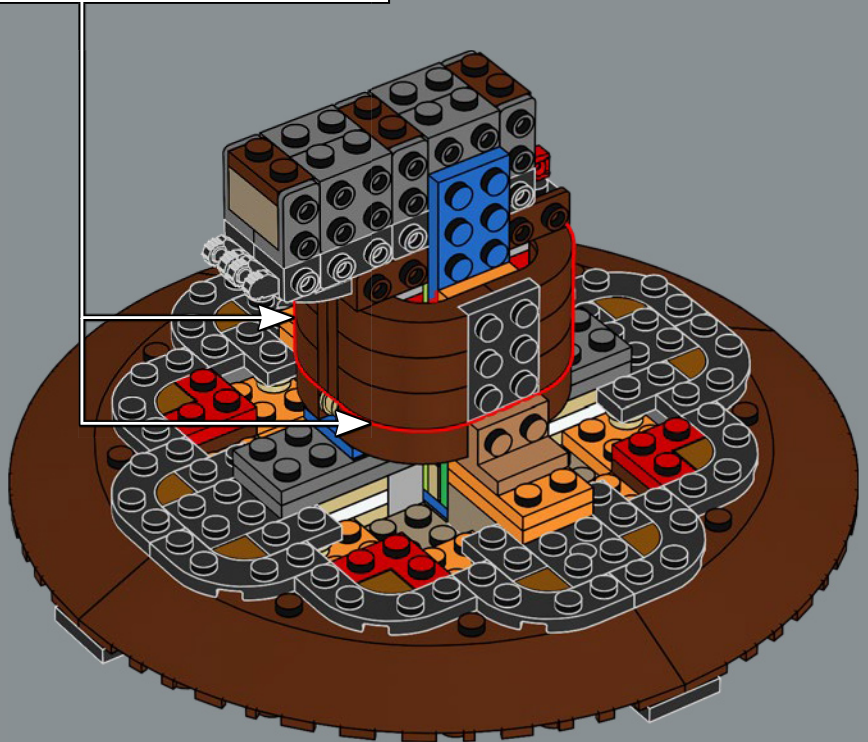
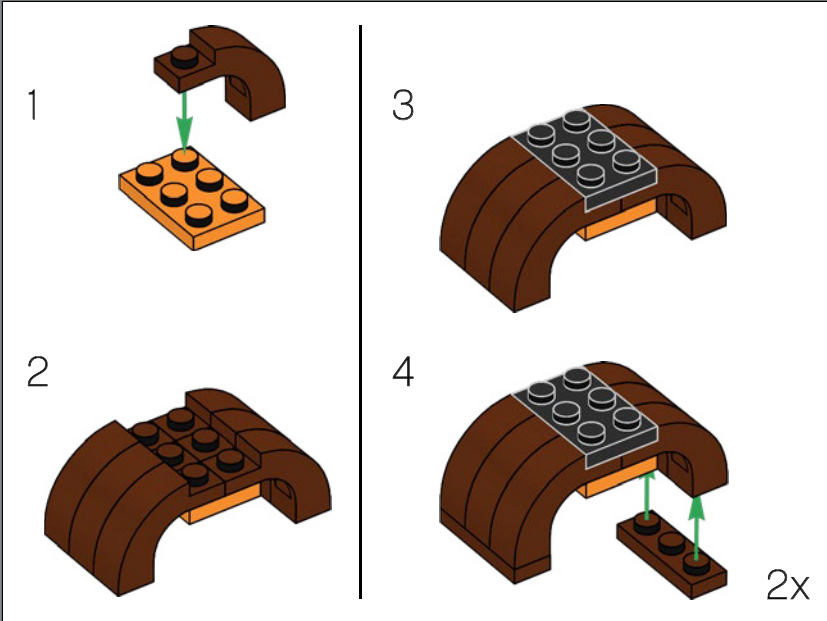

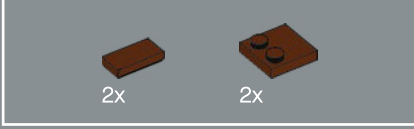
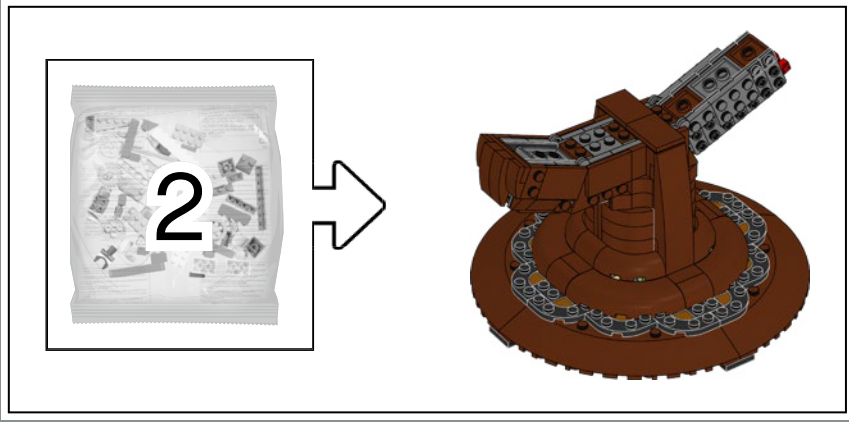

36

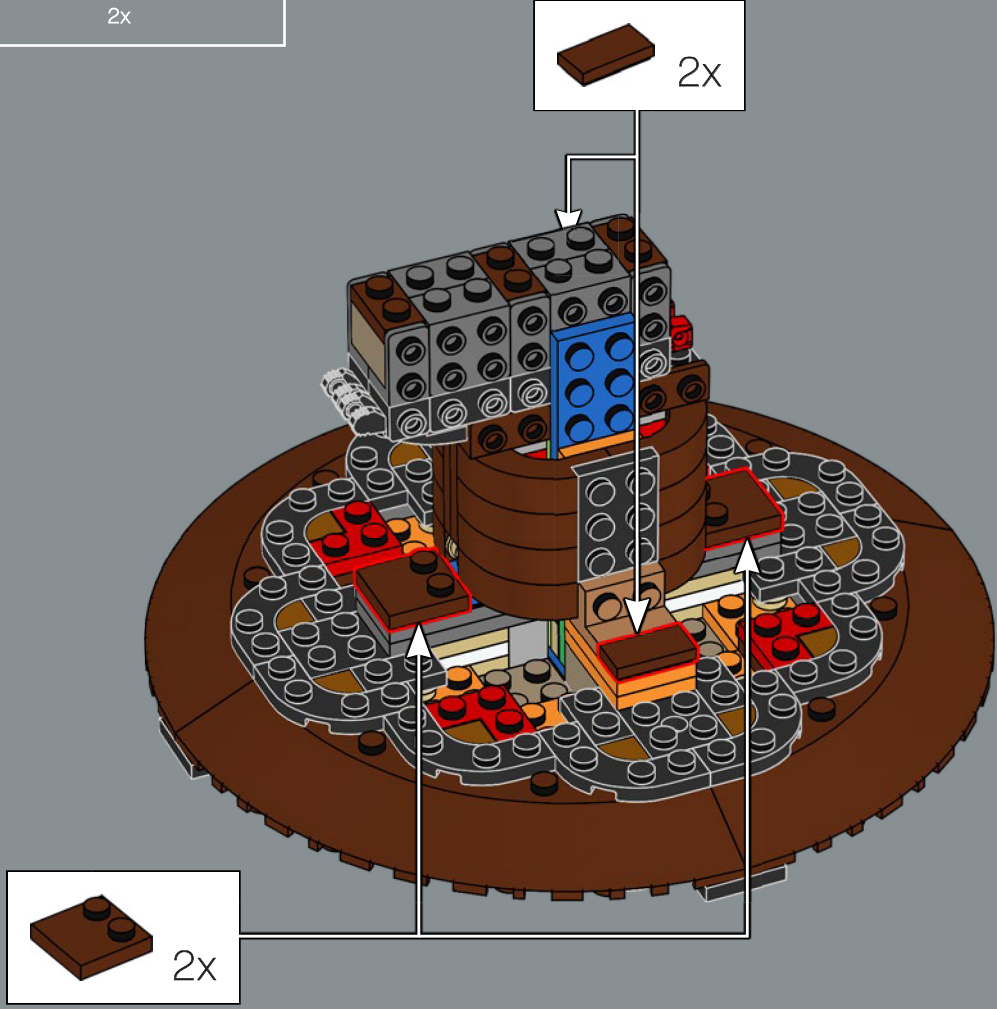

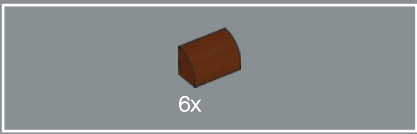

37

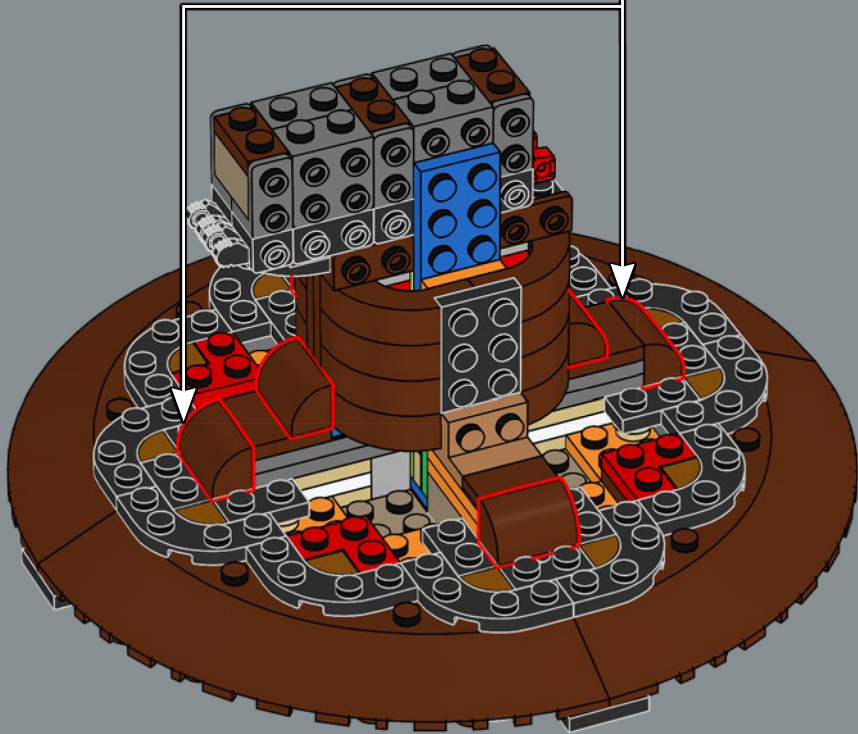

38

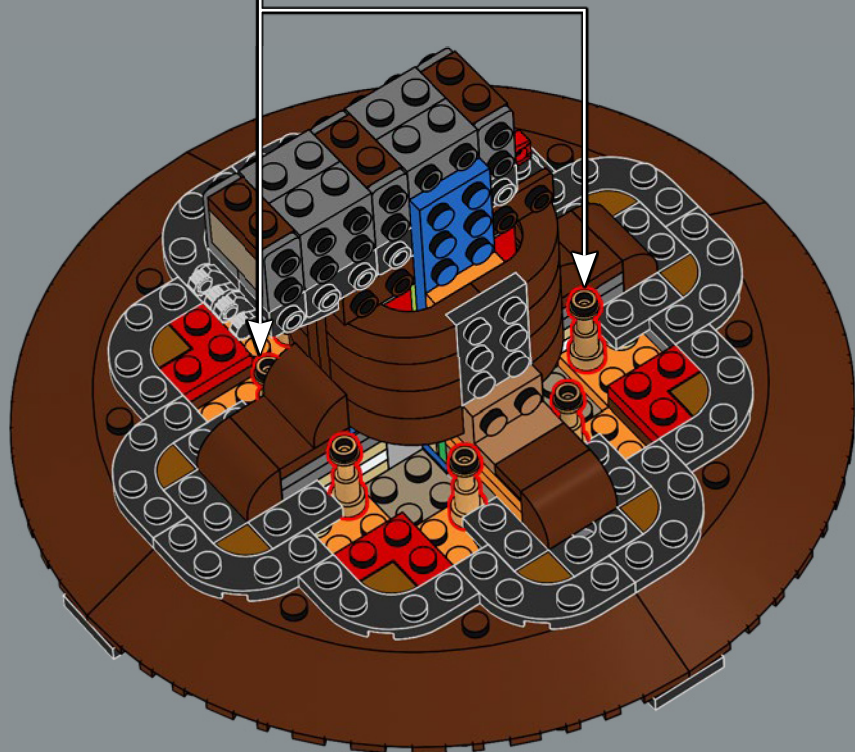



39

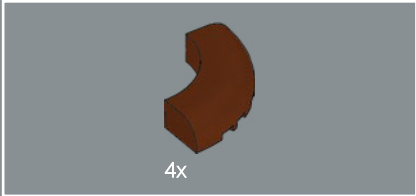

40

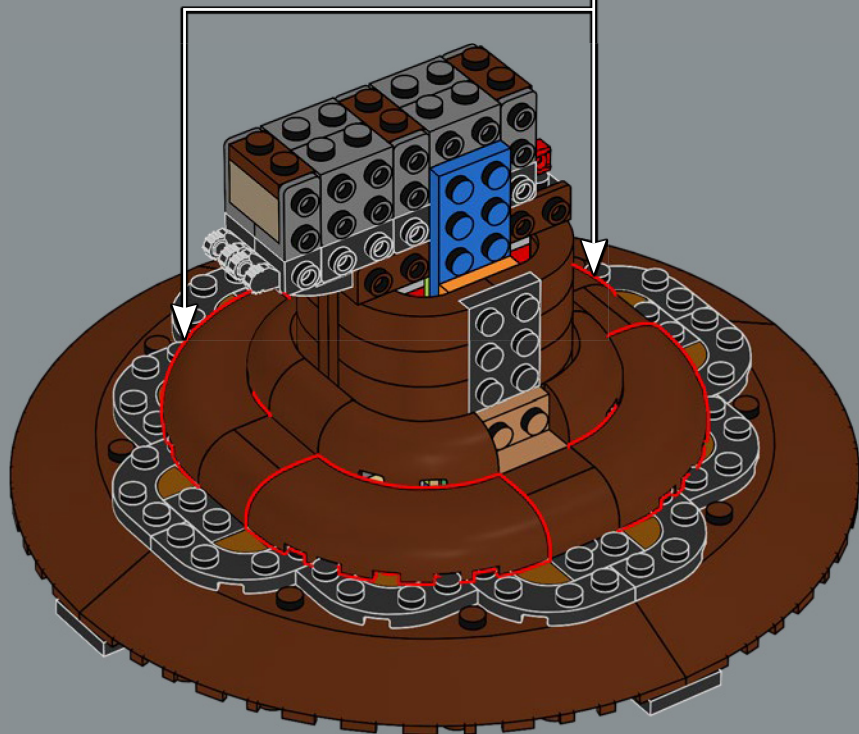

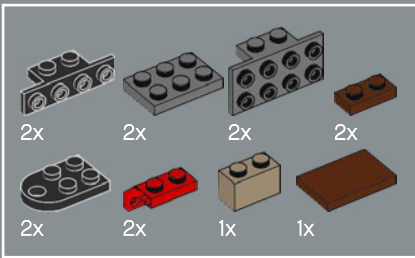

41

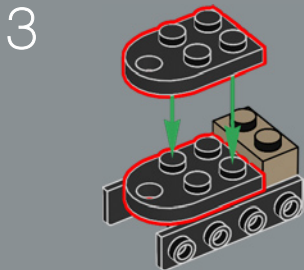
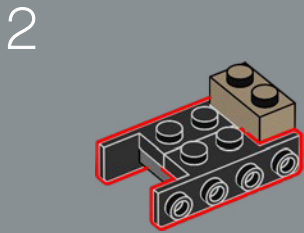
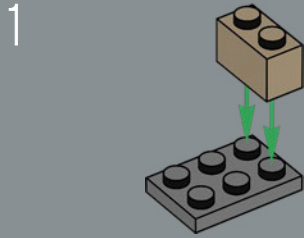

4

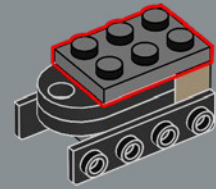

5

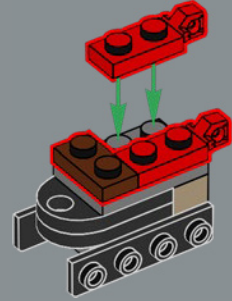

6

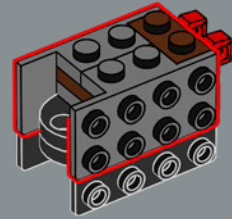

7

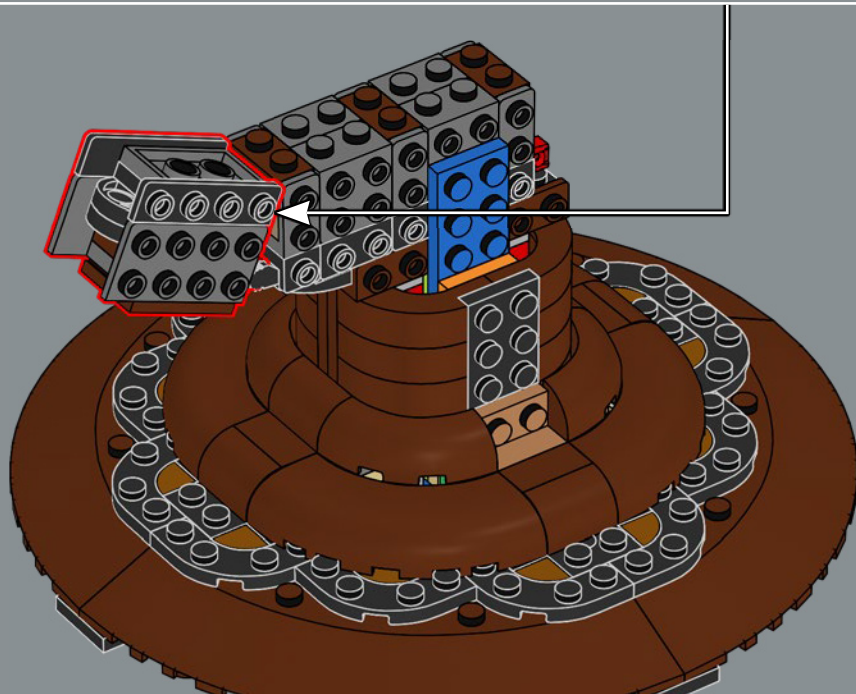
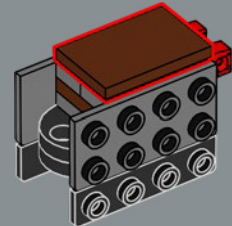

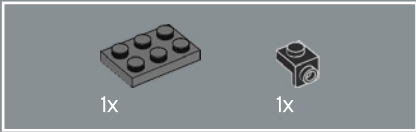
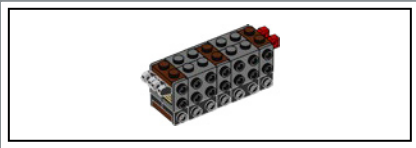

42

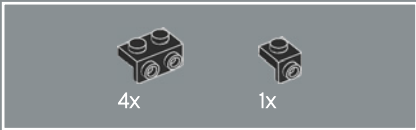
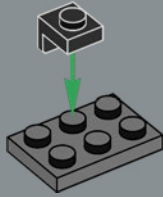

43

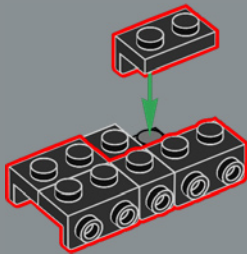

44

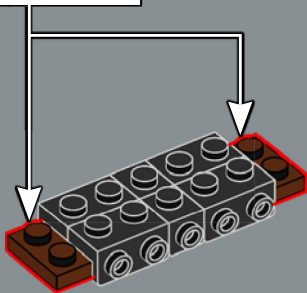

45

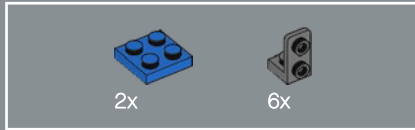
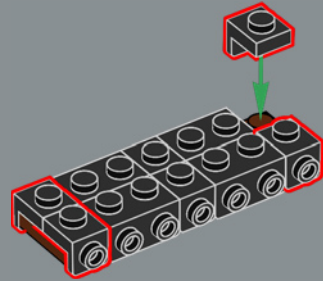

46

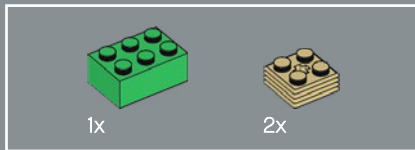
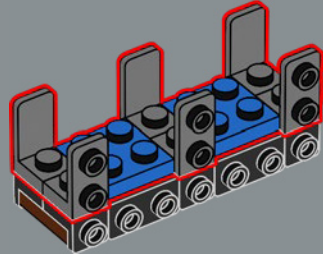

47

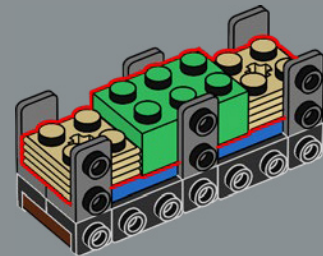



48

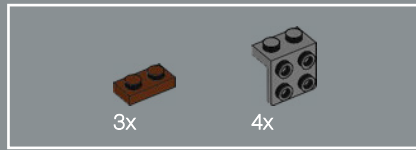
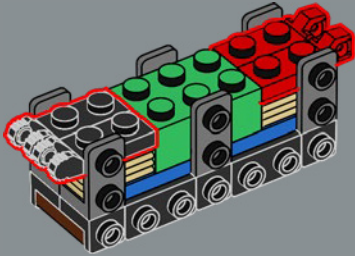

49

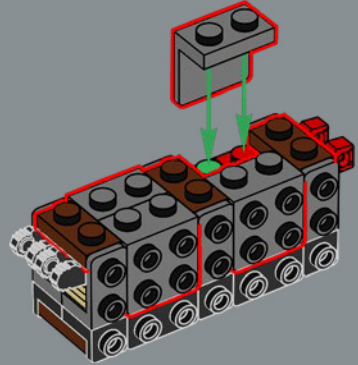

50

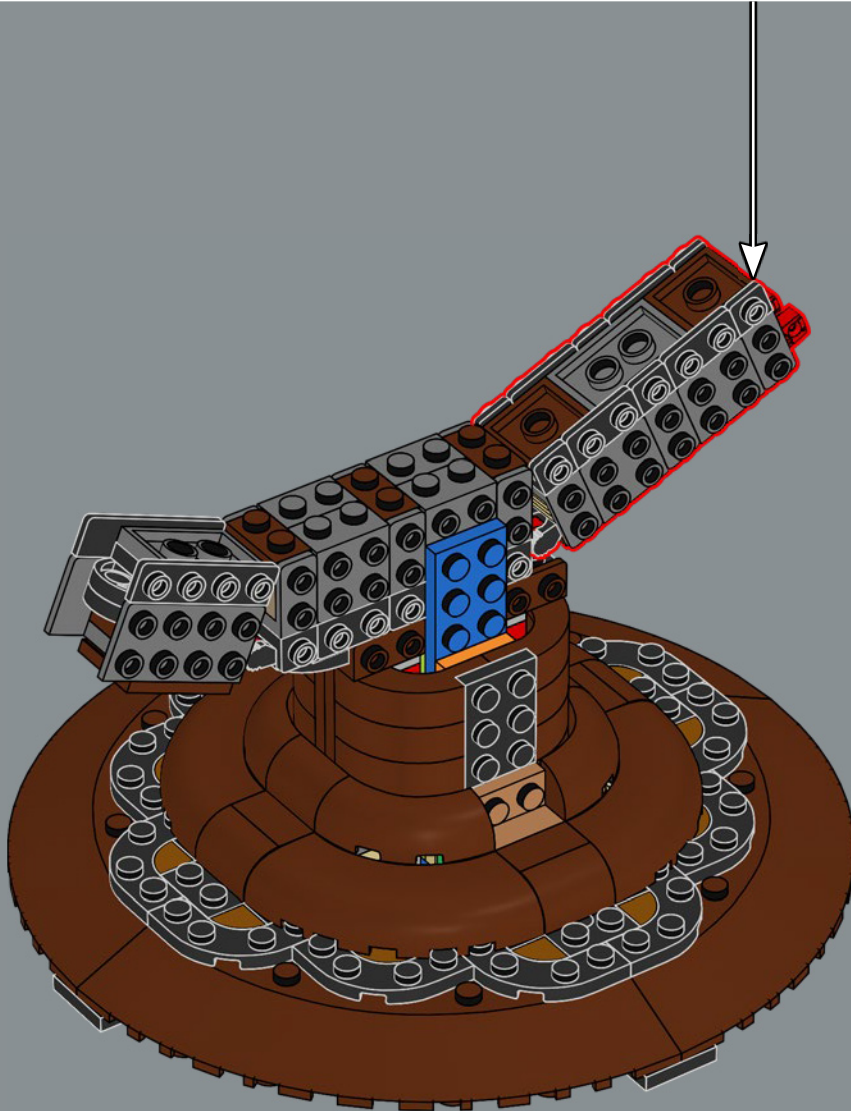

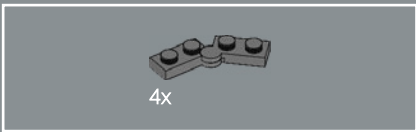

51

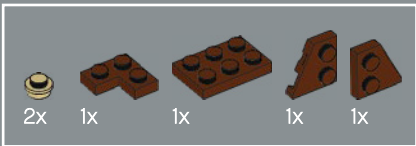
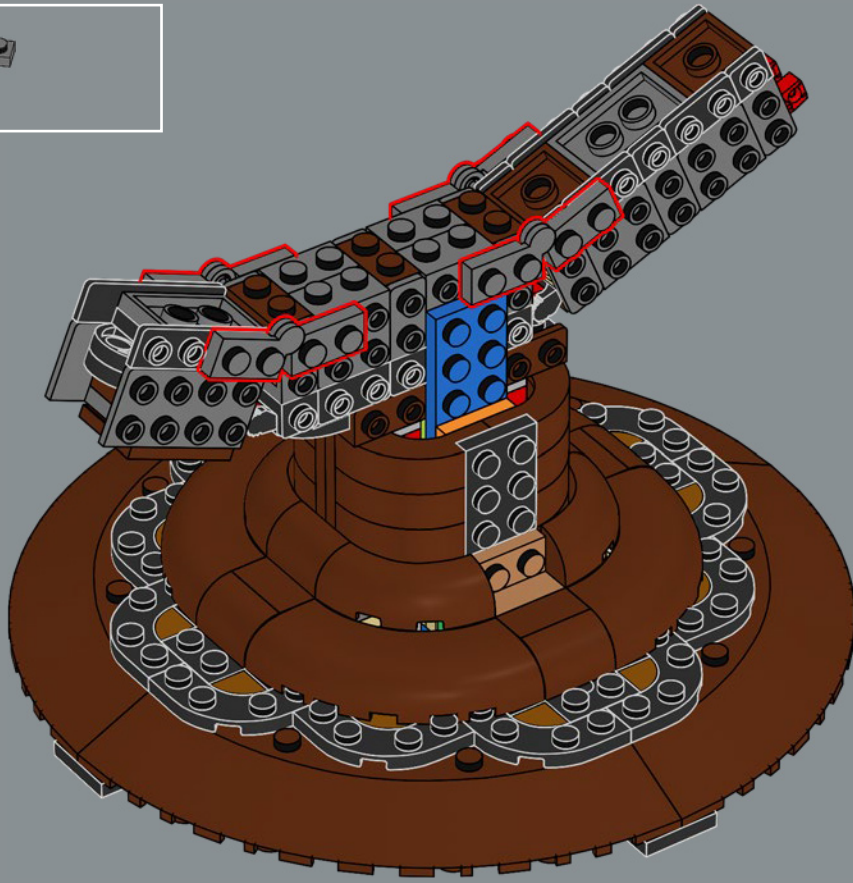

52



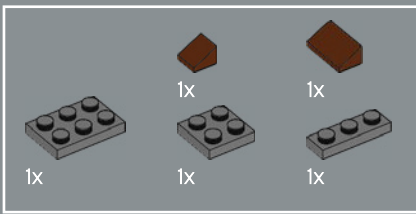

53

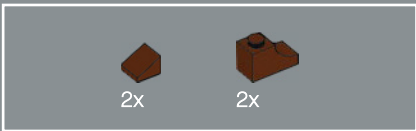

54

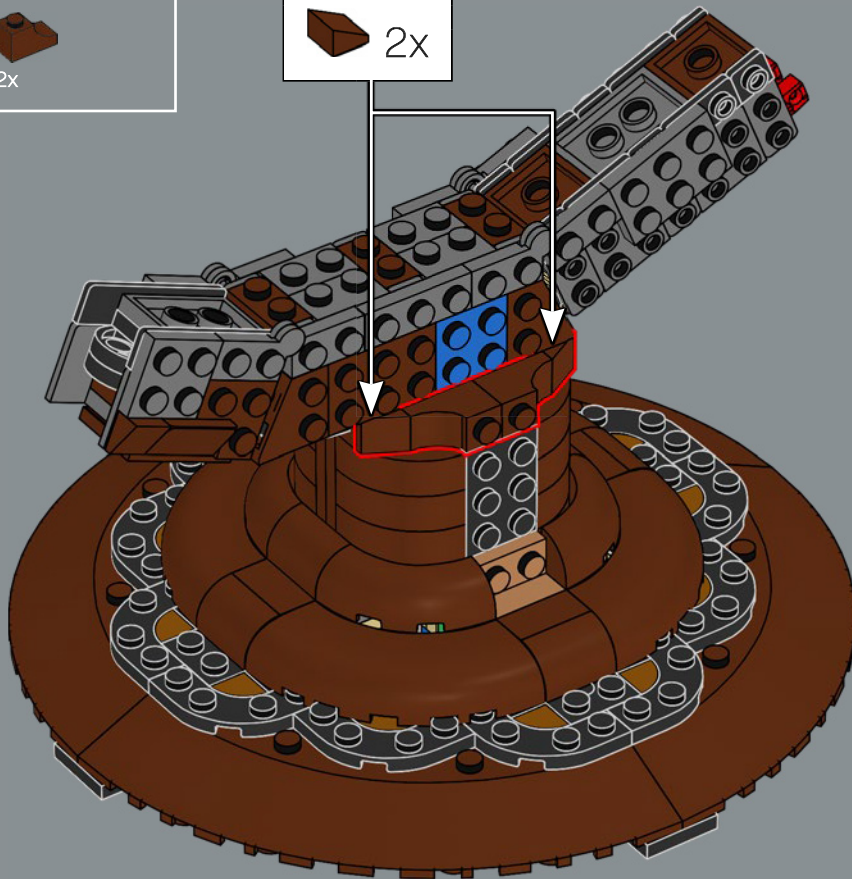

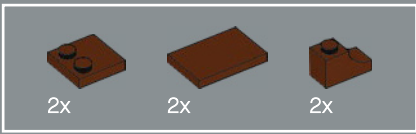

55

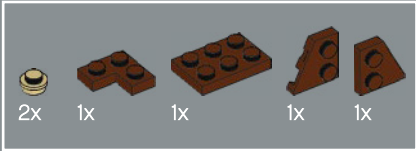
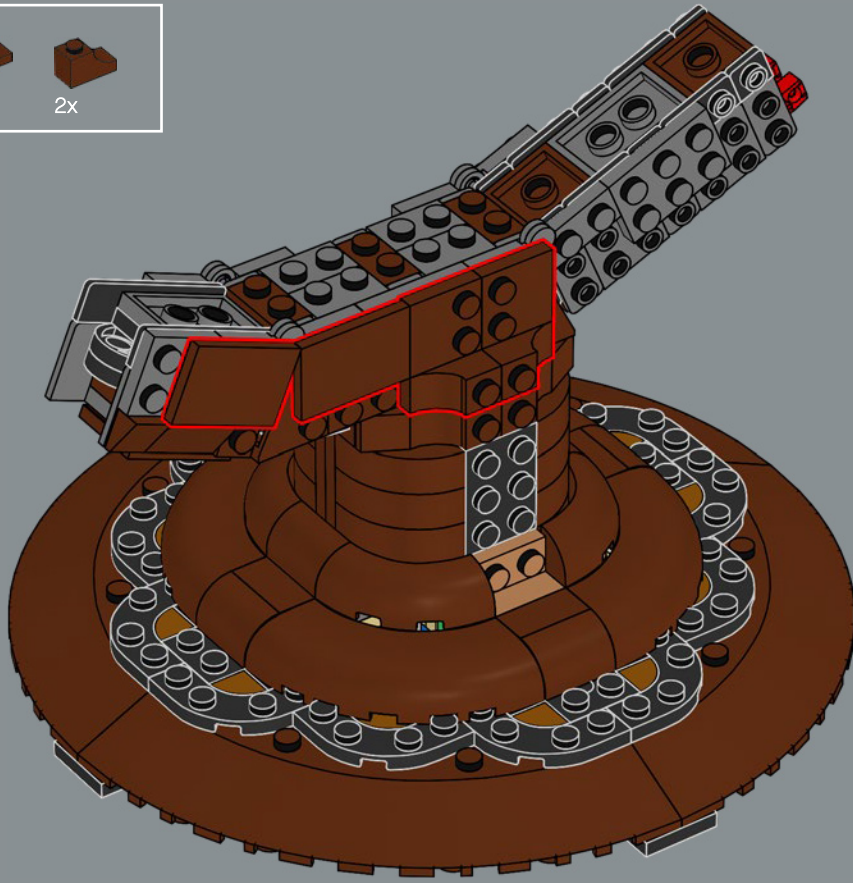

56

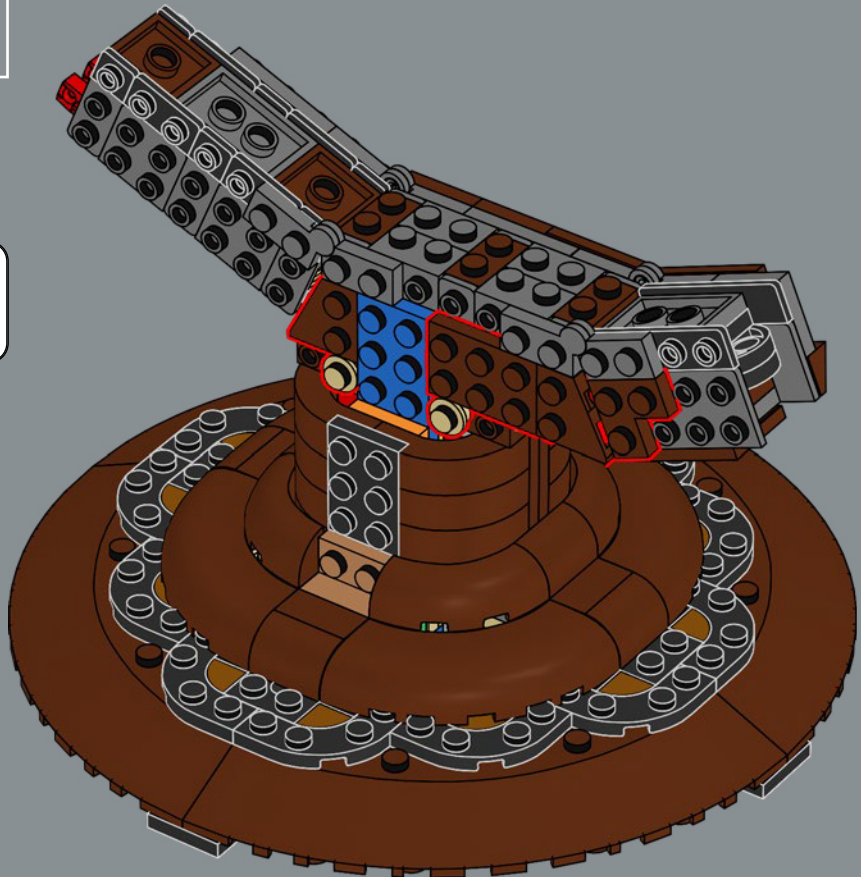

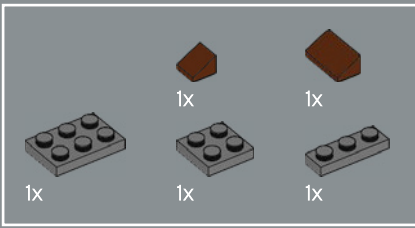

57

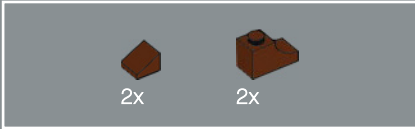

58



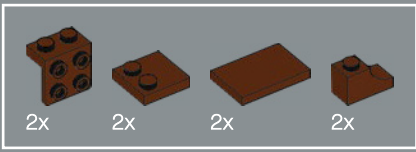

59

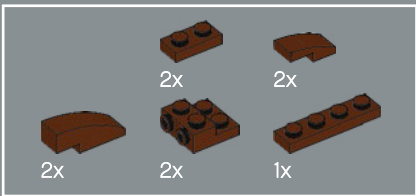
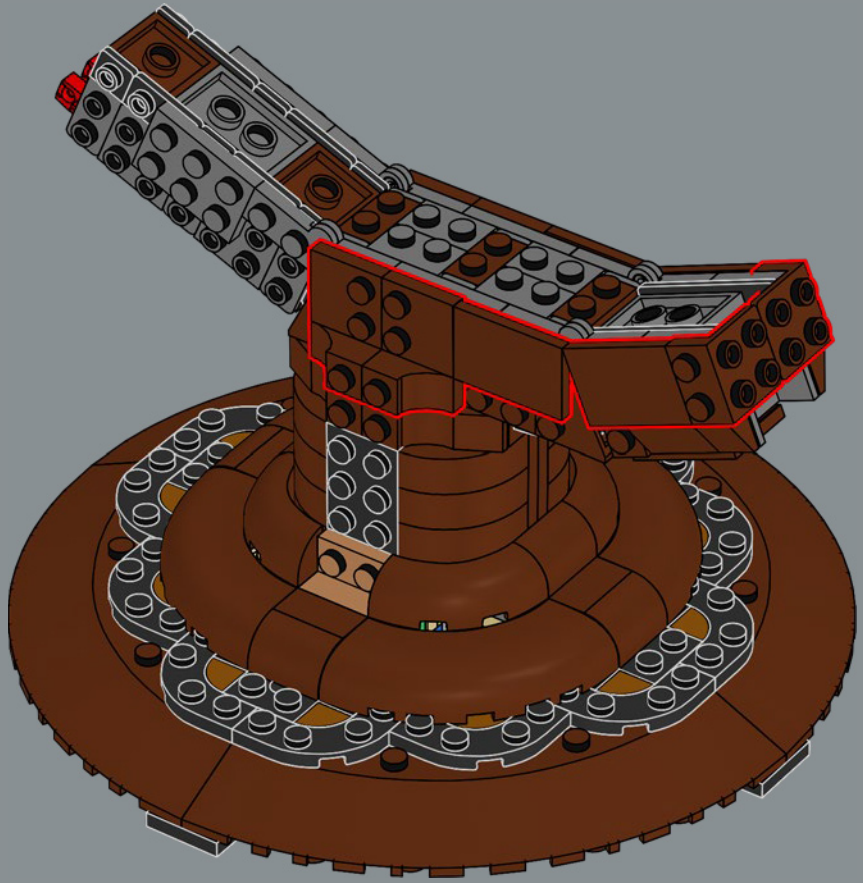

60

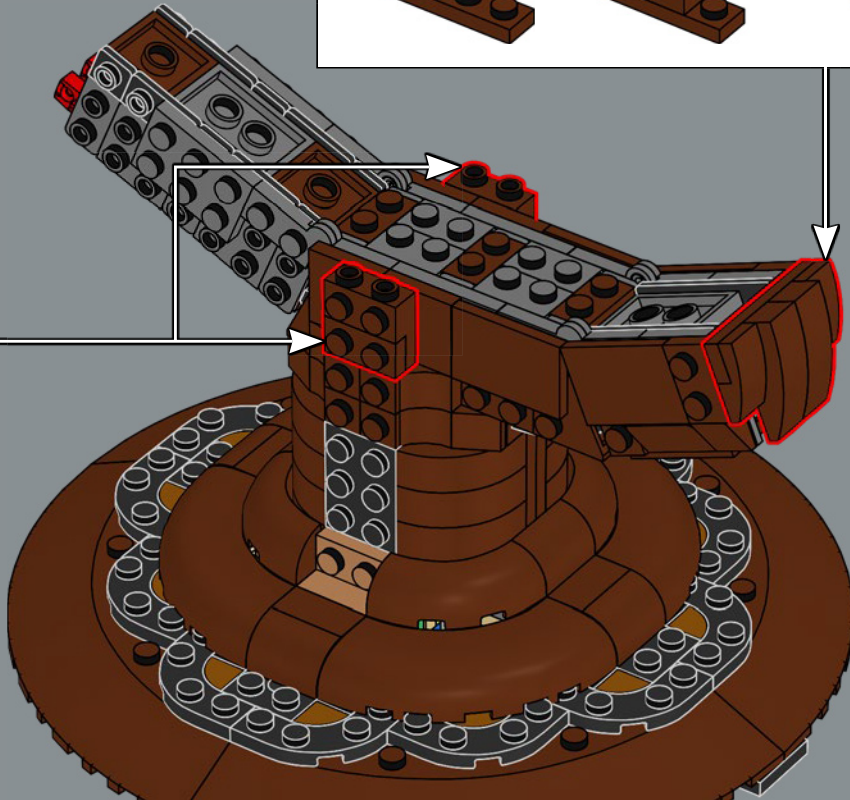
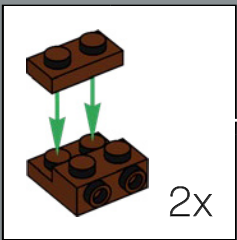
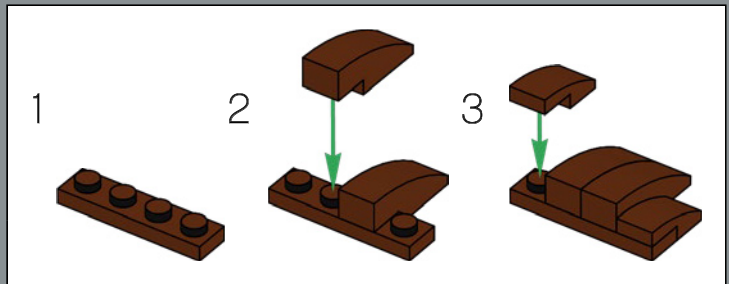

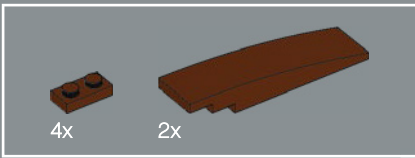

61

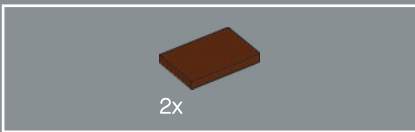
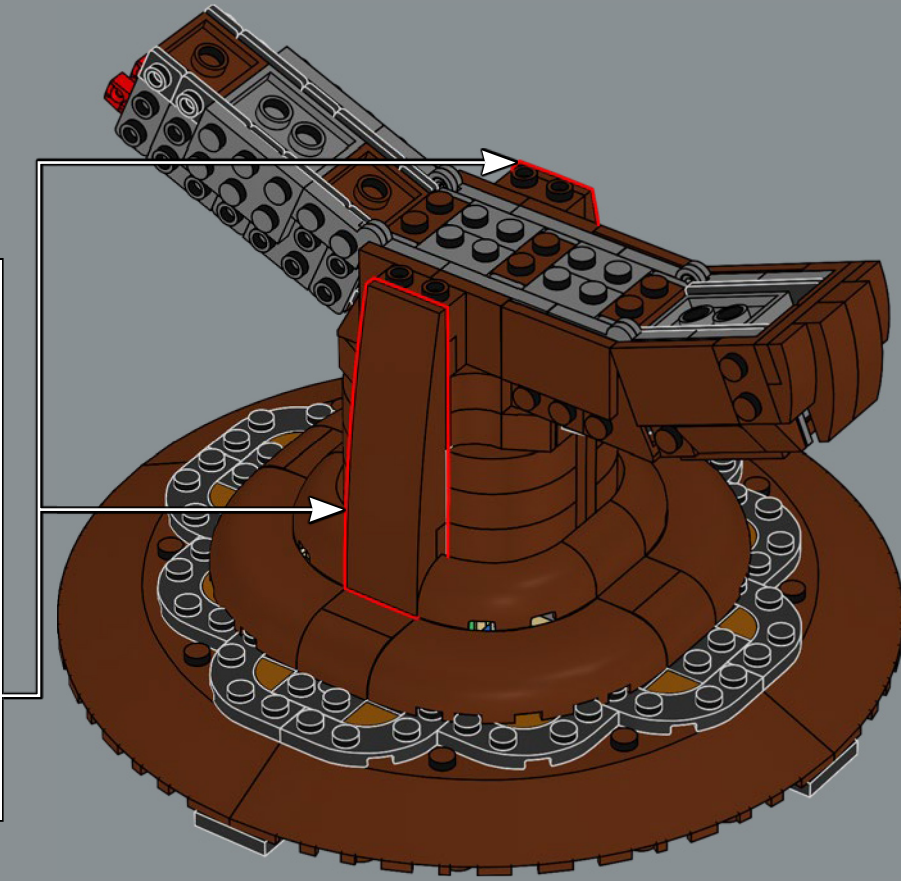
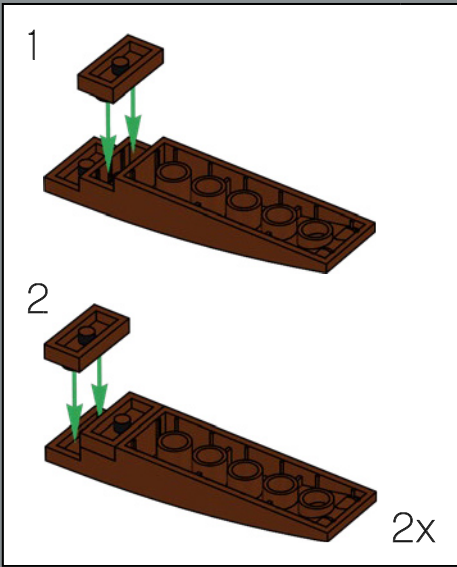

62

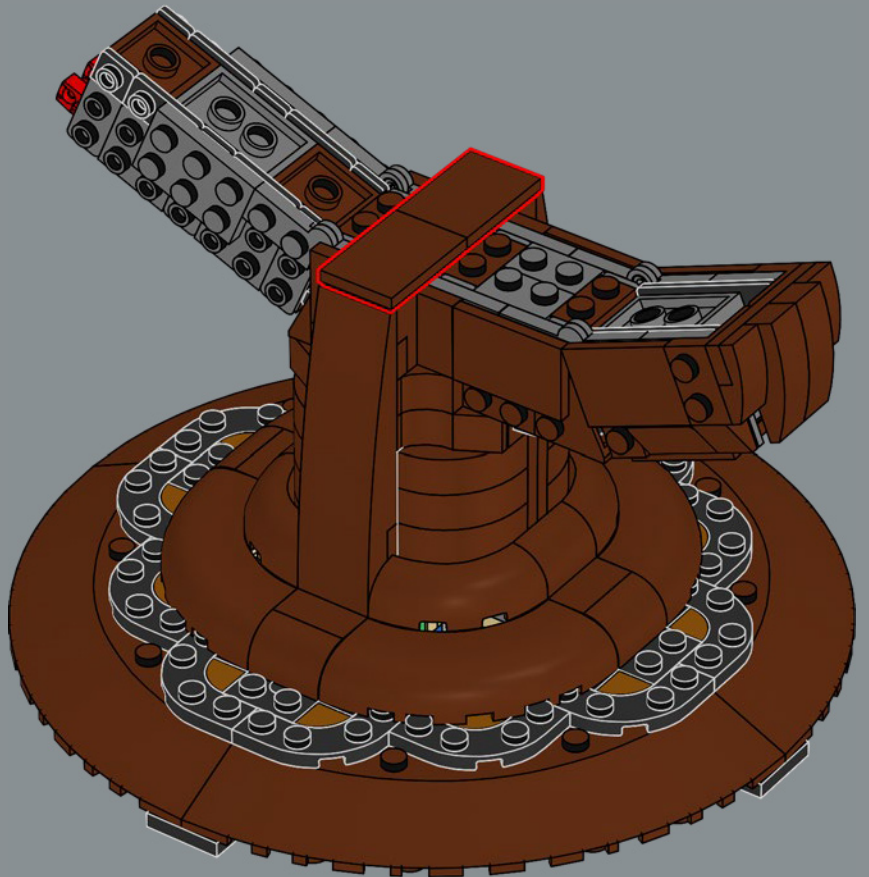

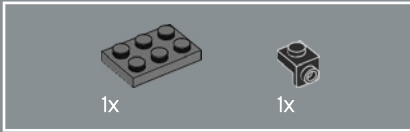
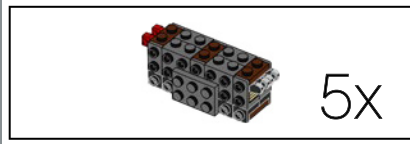

63

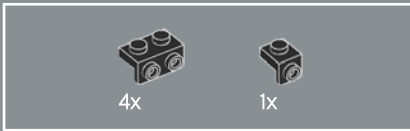
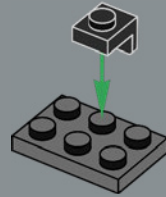

64

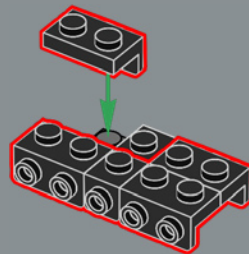

65

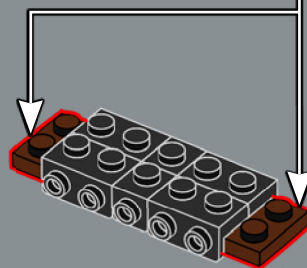



66

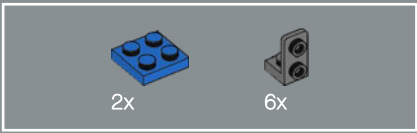
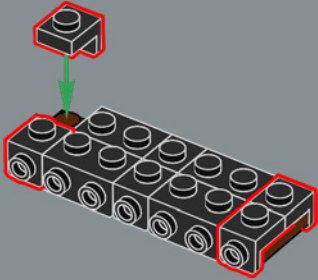

67

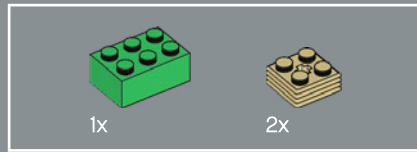
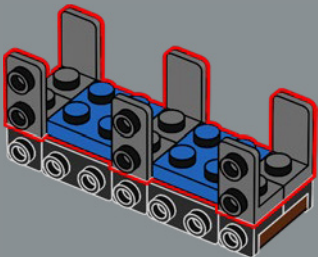

68

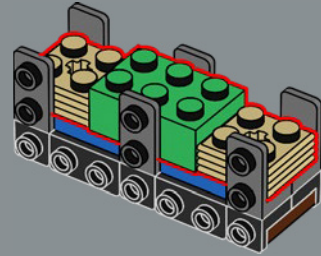

69

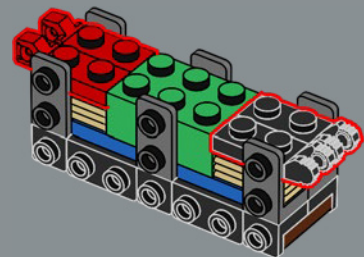

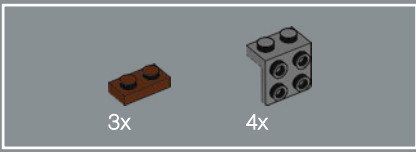

70

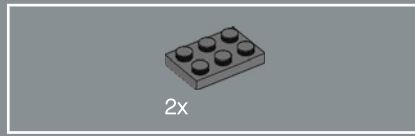
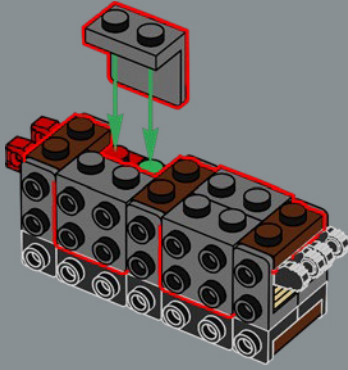

71

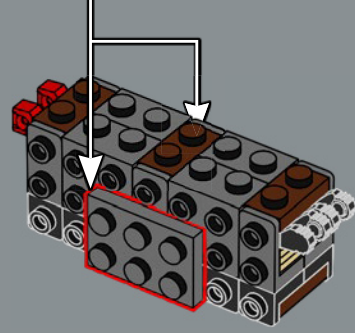
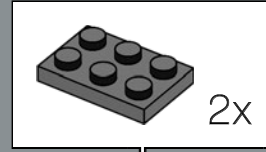

5x

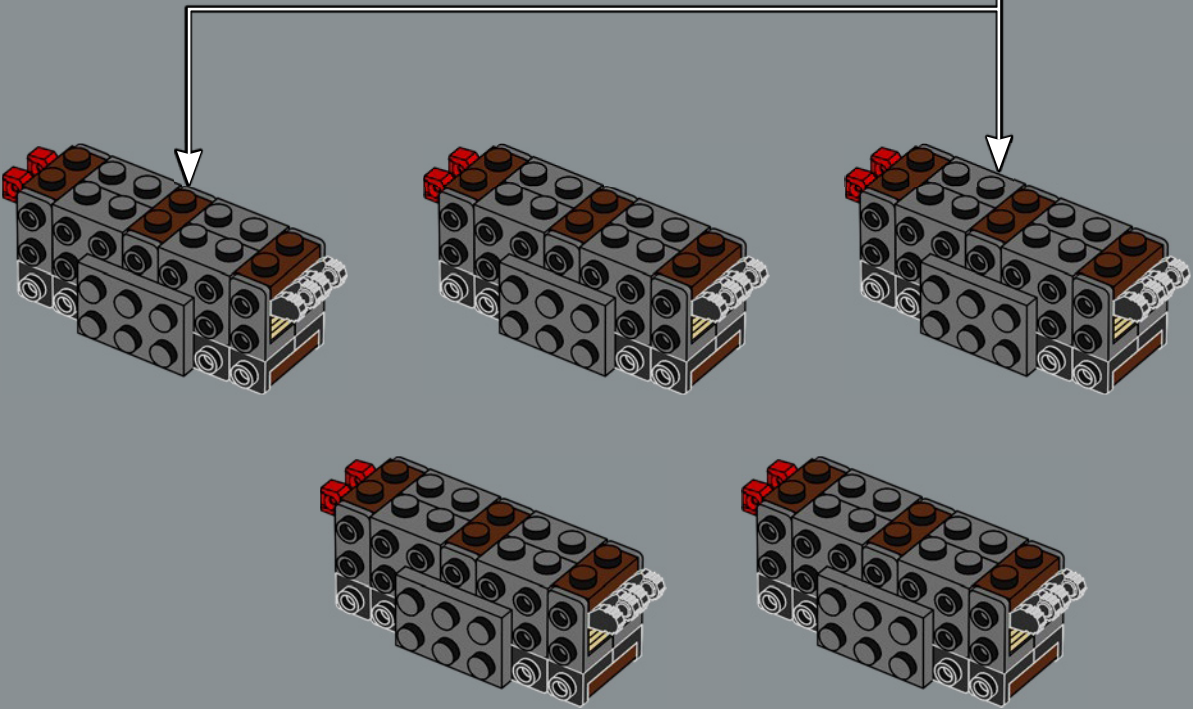

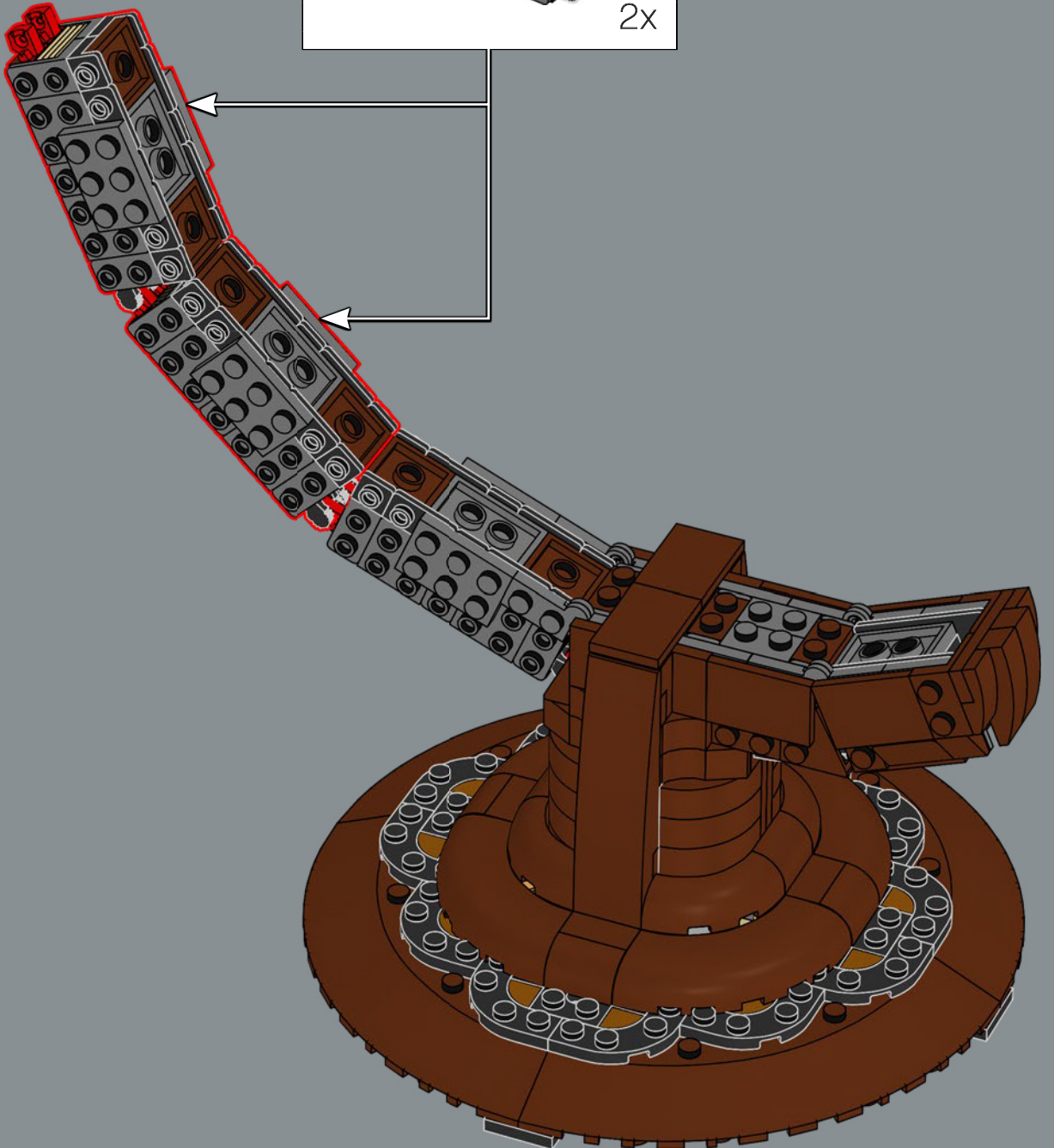
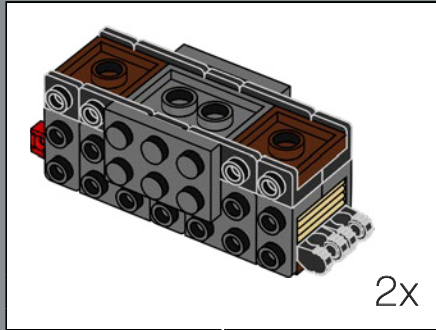

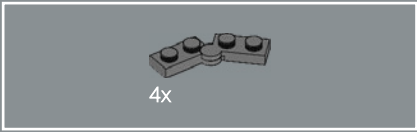

73

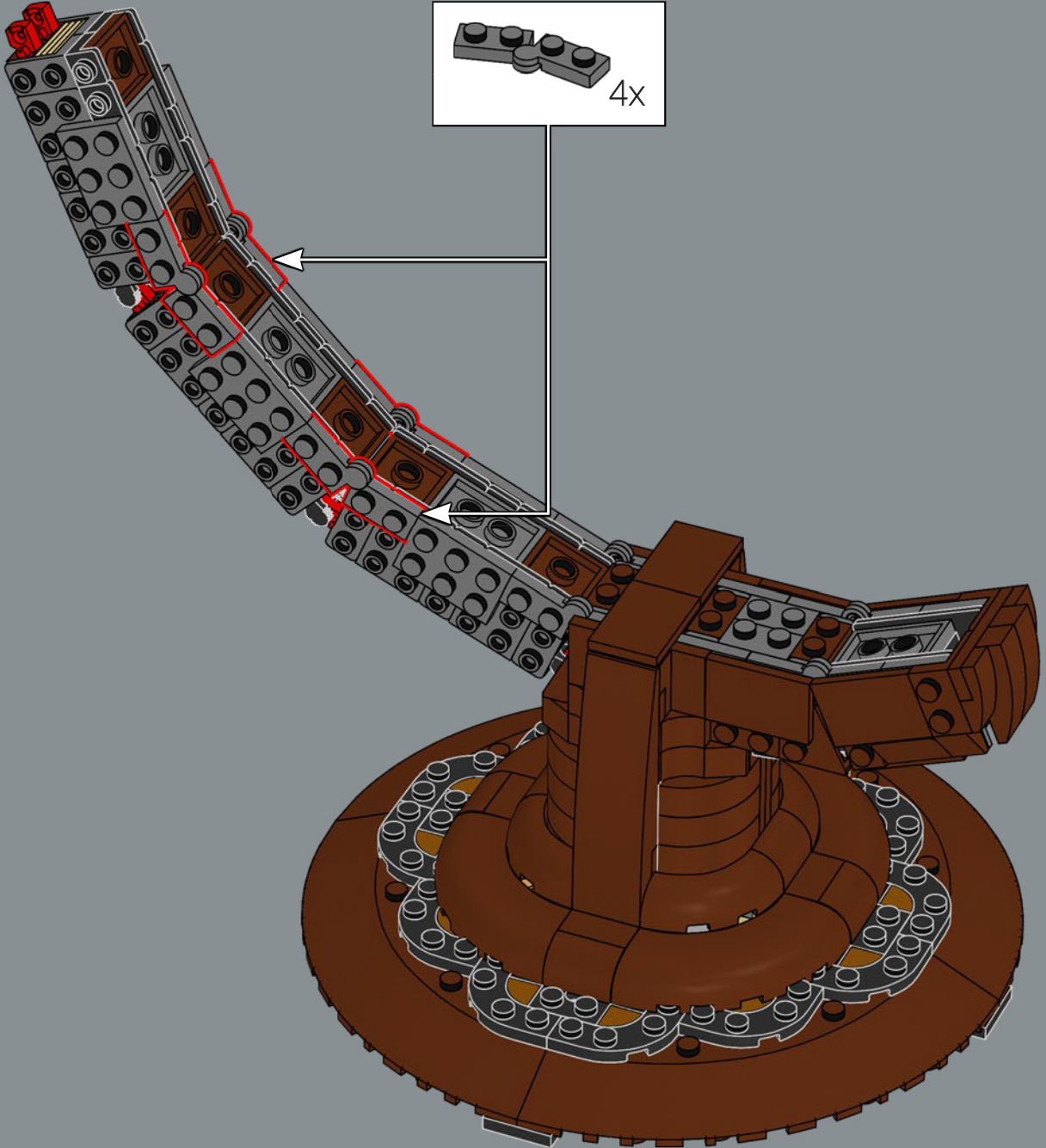

74

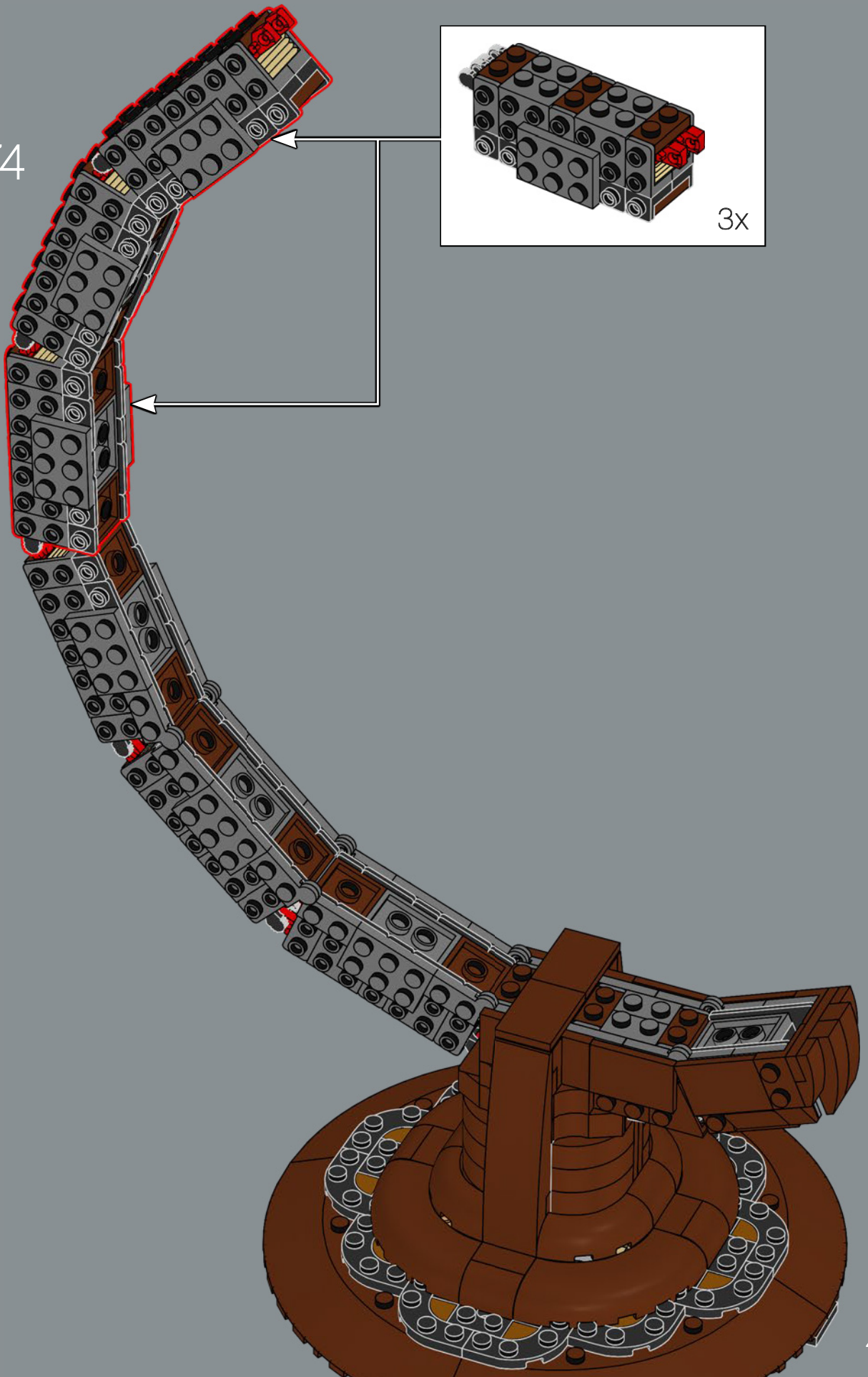

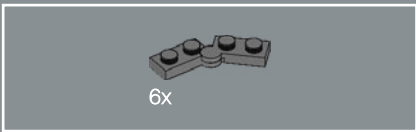

75

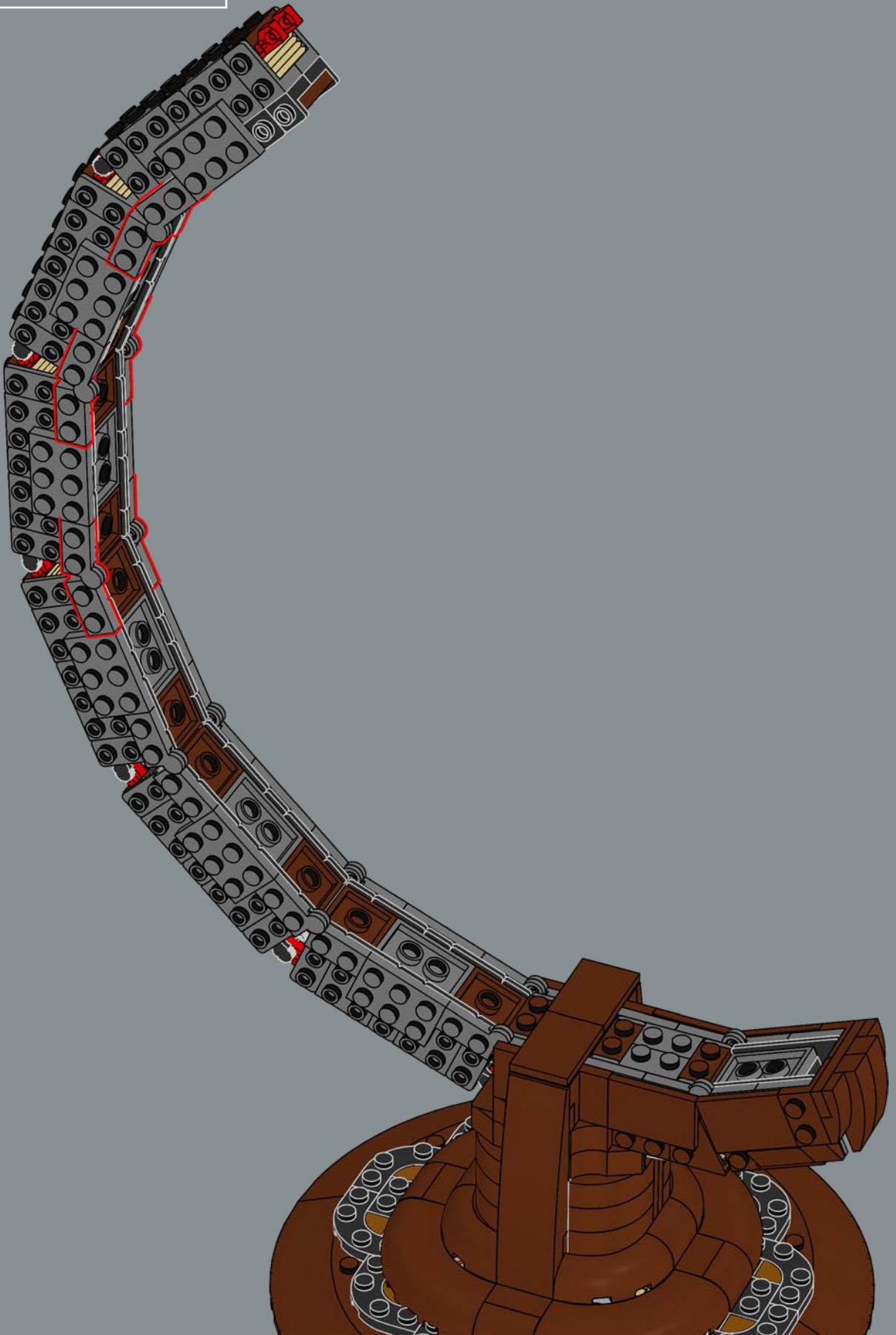

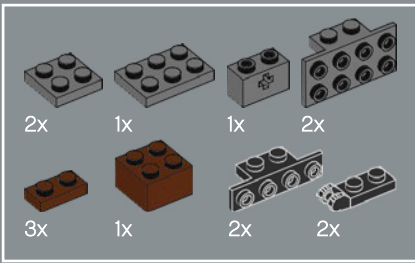

76

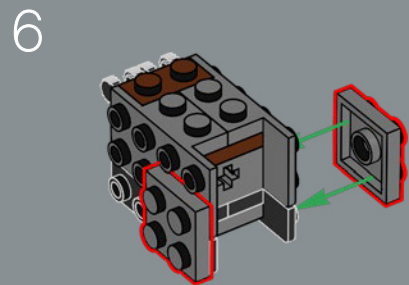
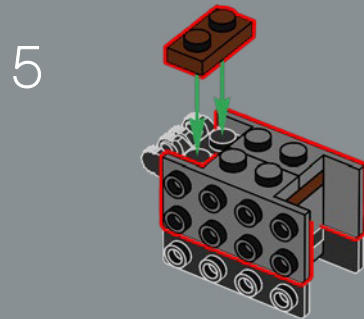
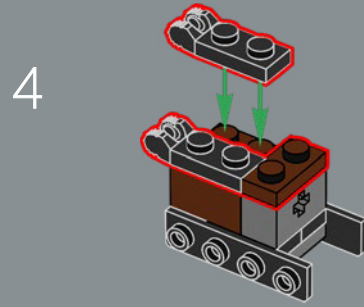
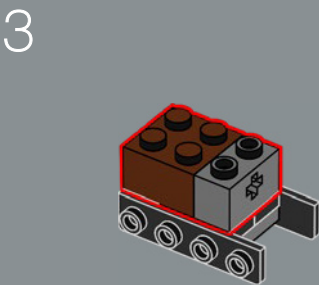
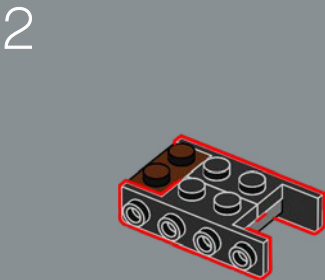
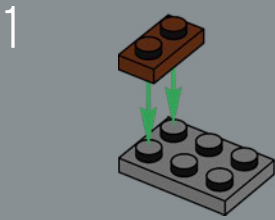

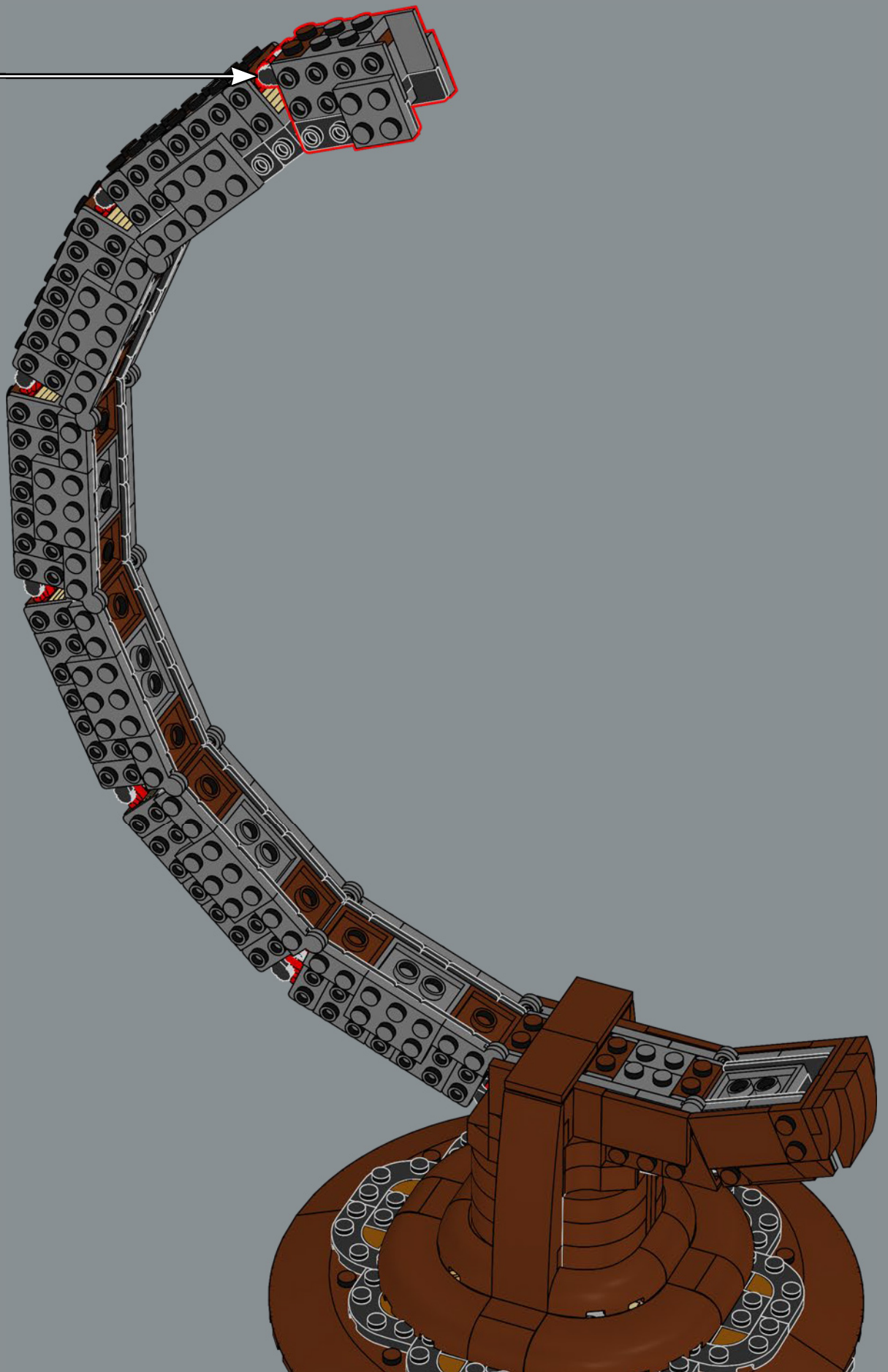

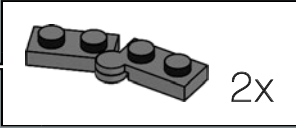
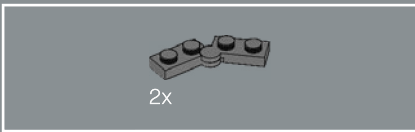

77

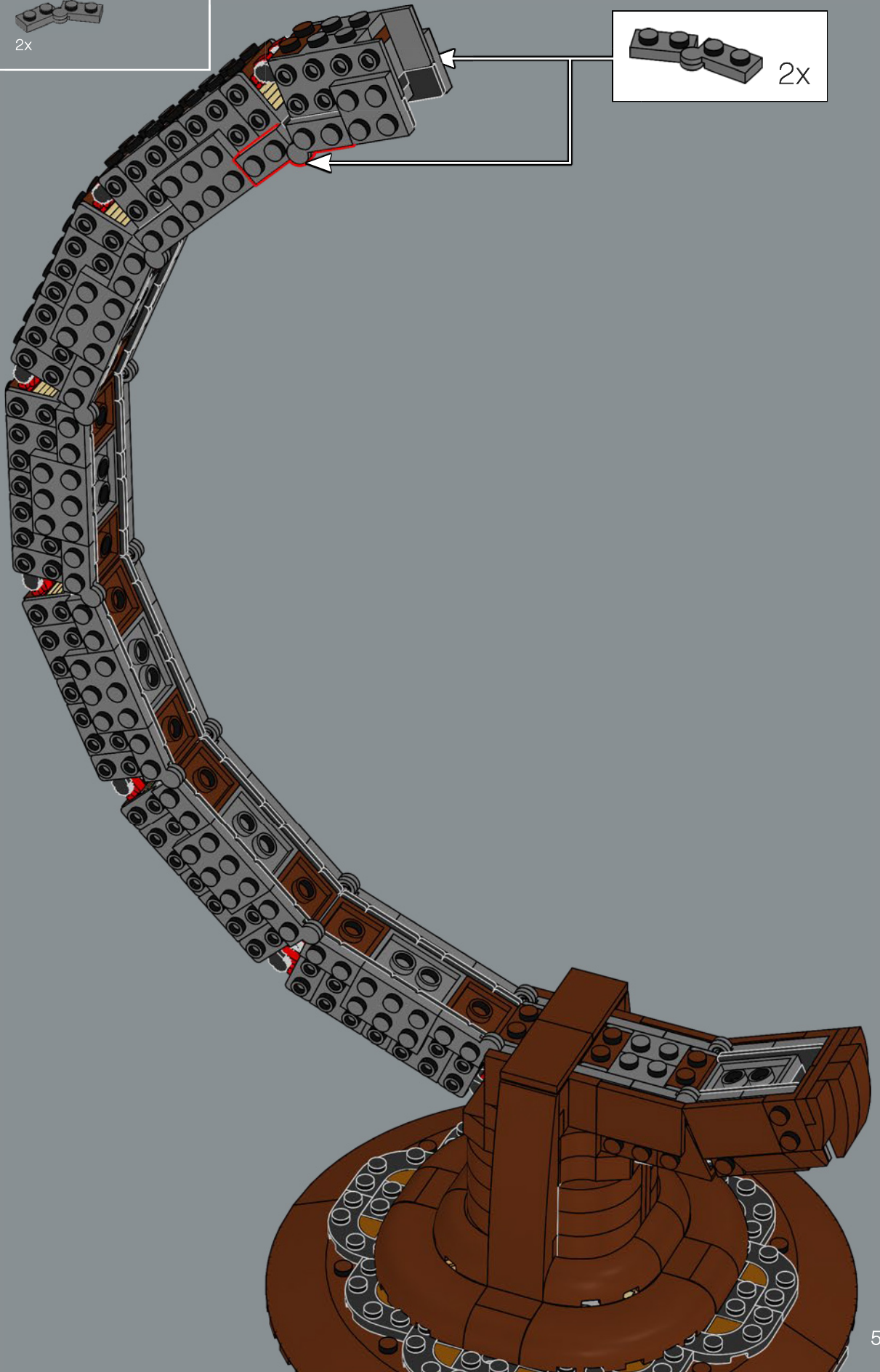

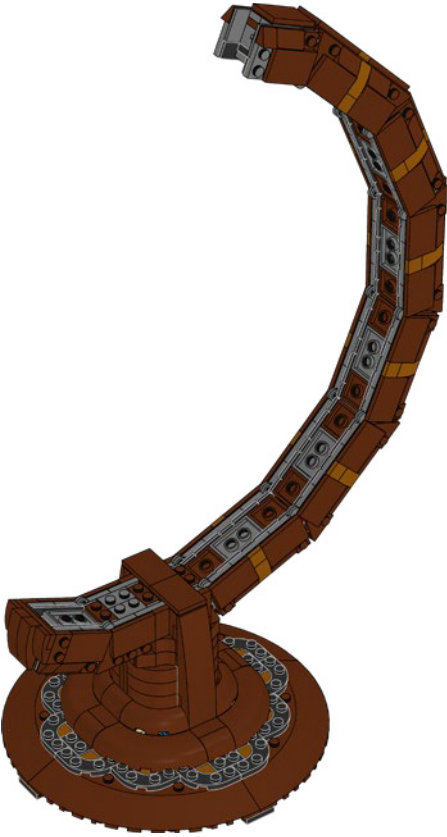

6x



6x

78



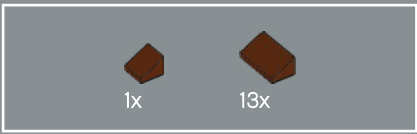

79

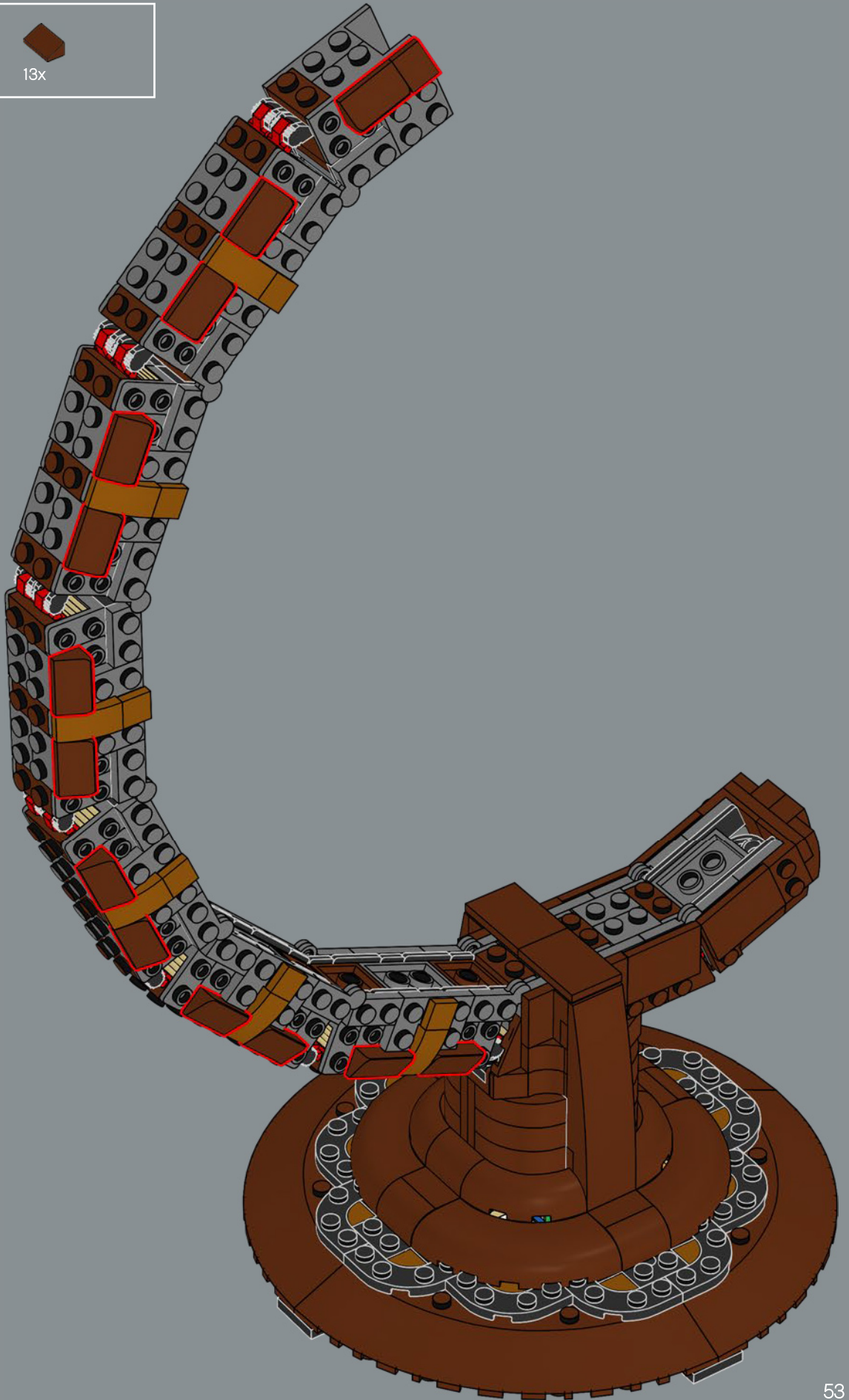



80

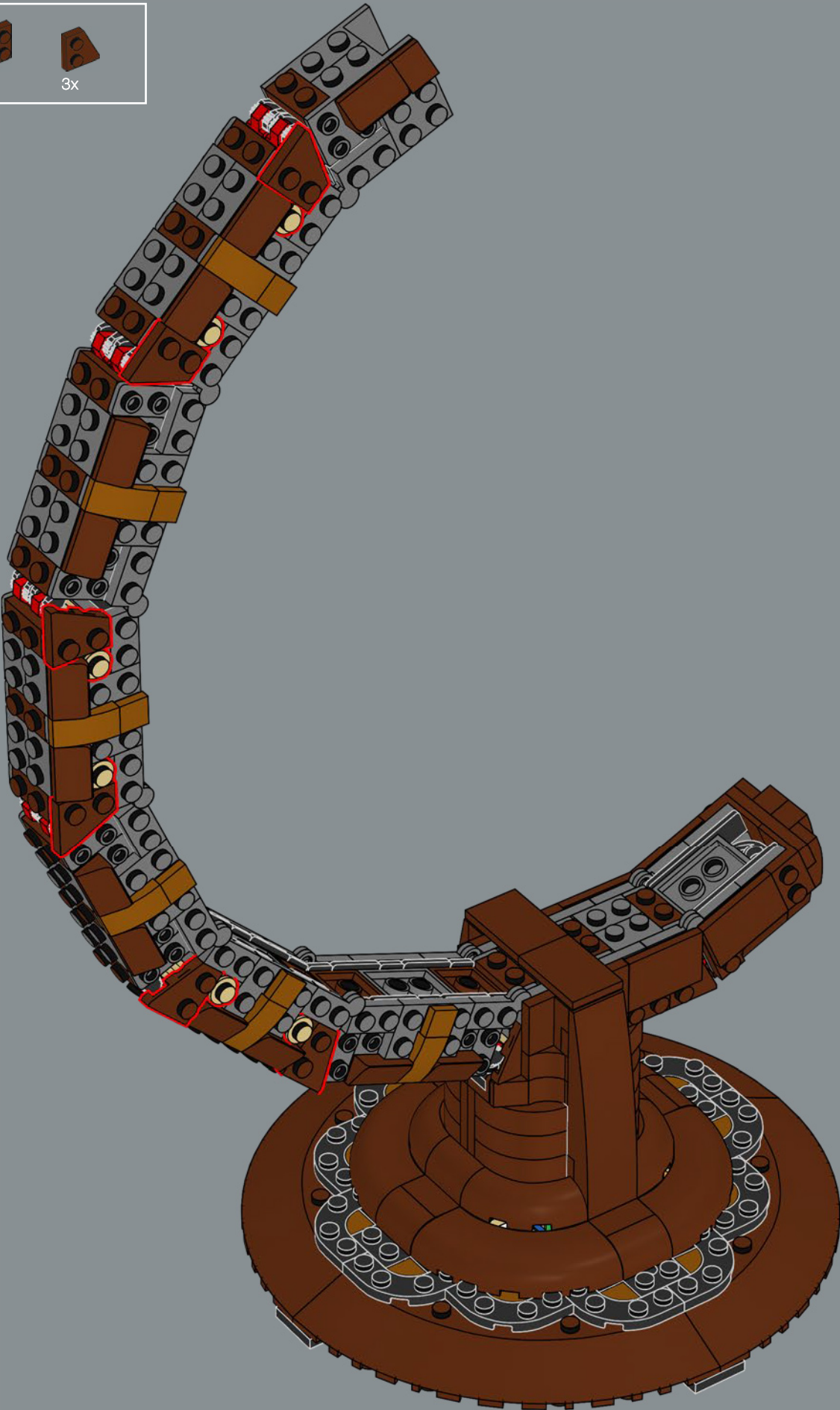



81

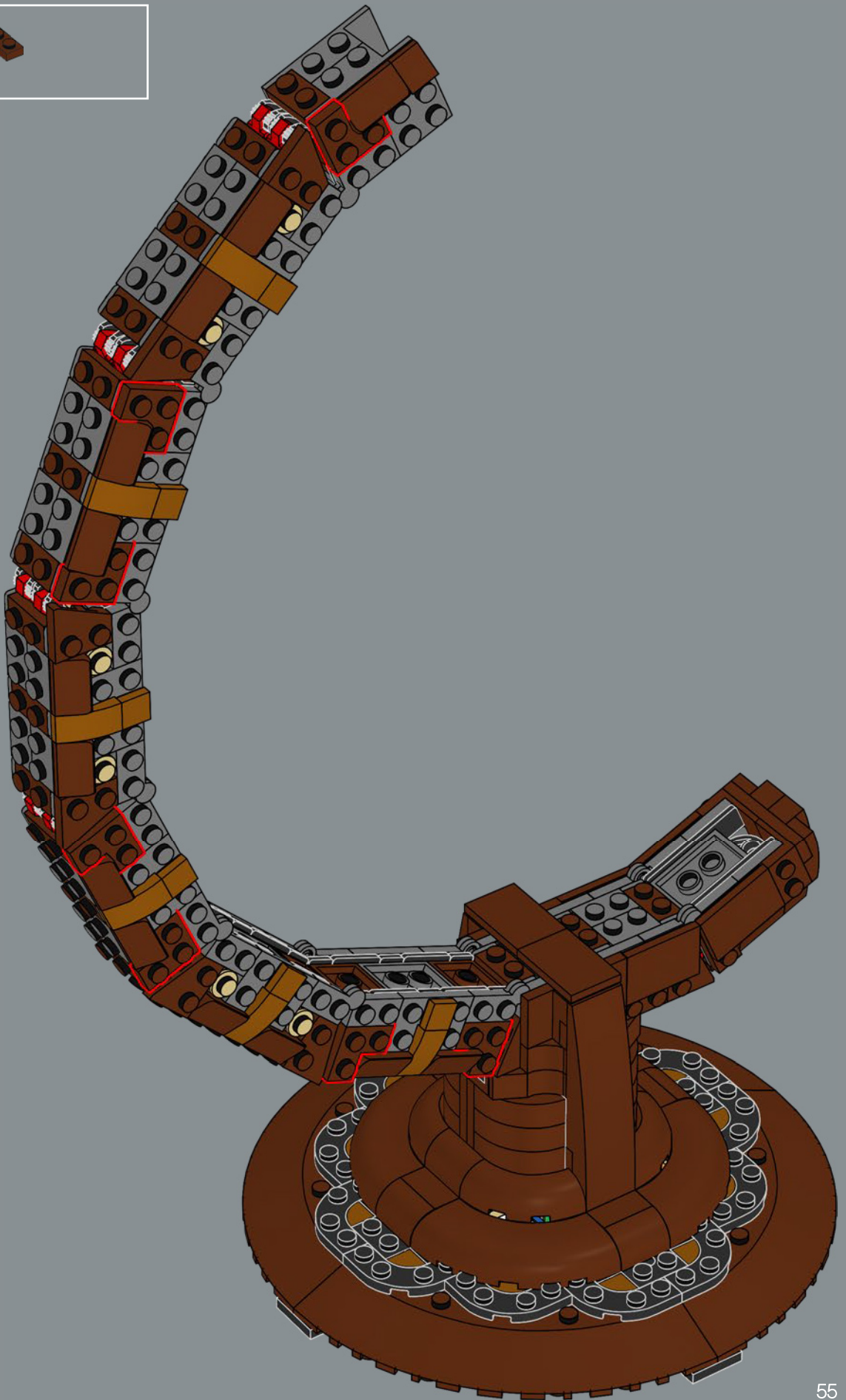



82

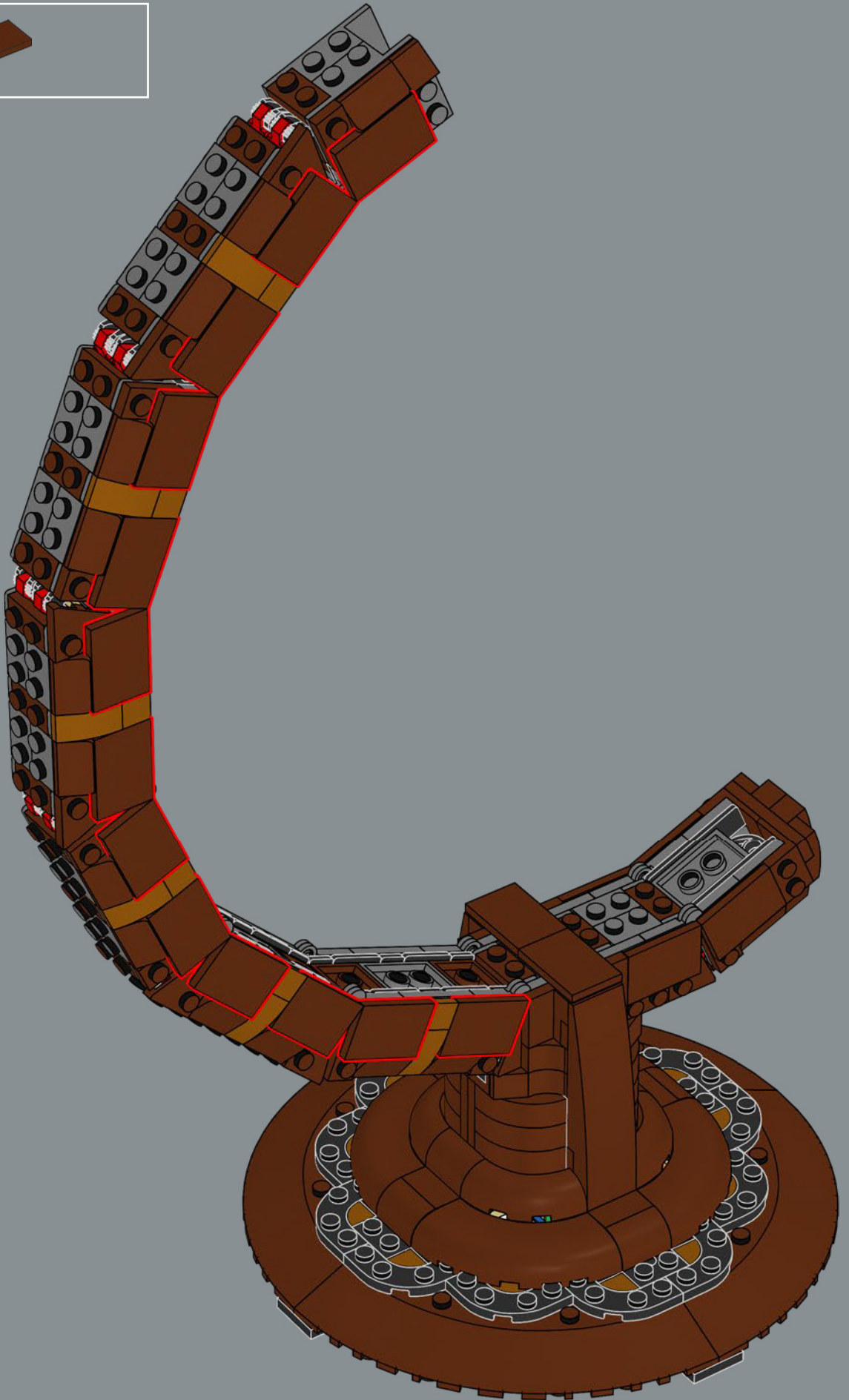

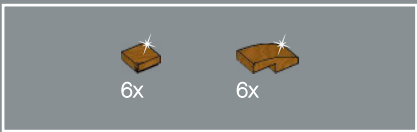

83

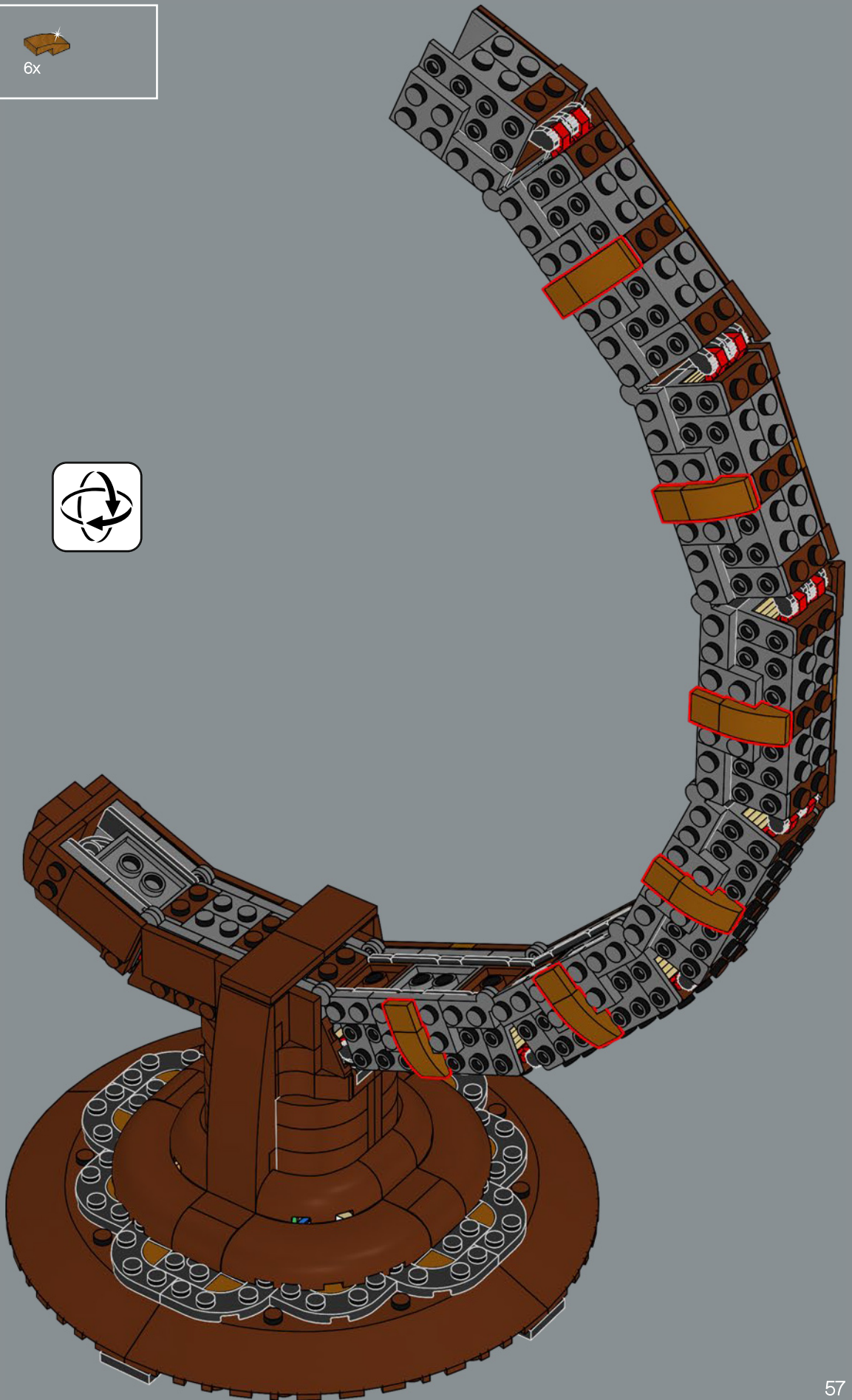

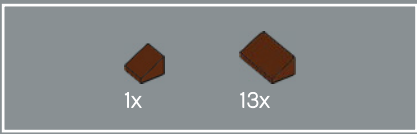

84

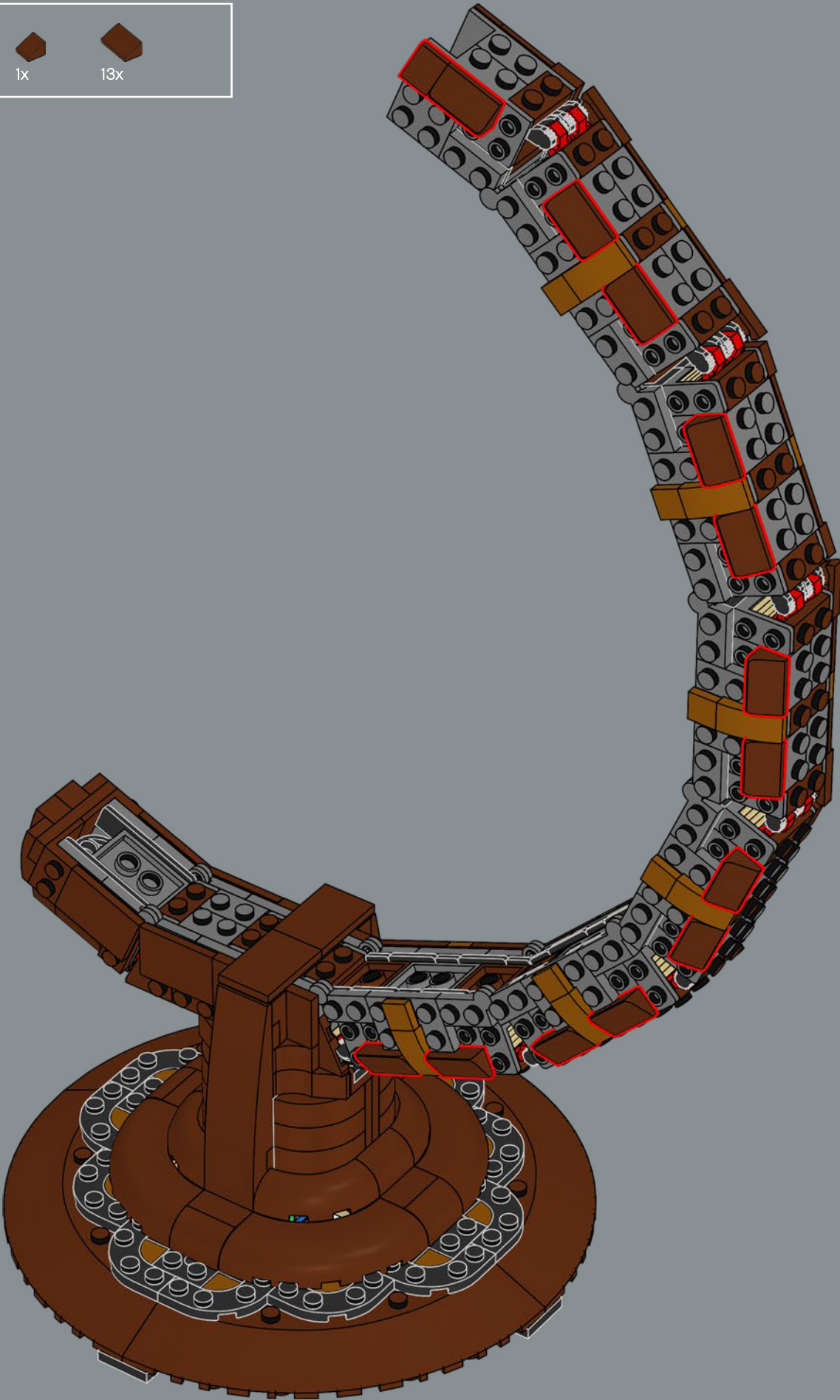



85

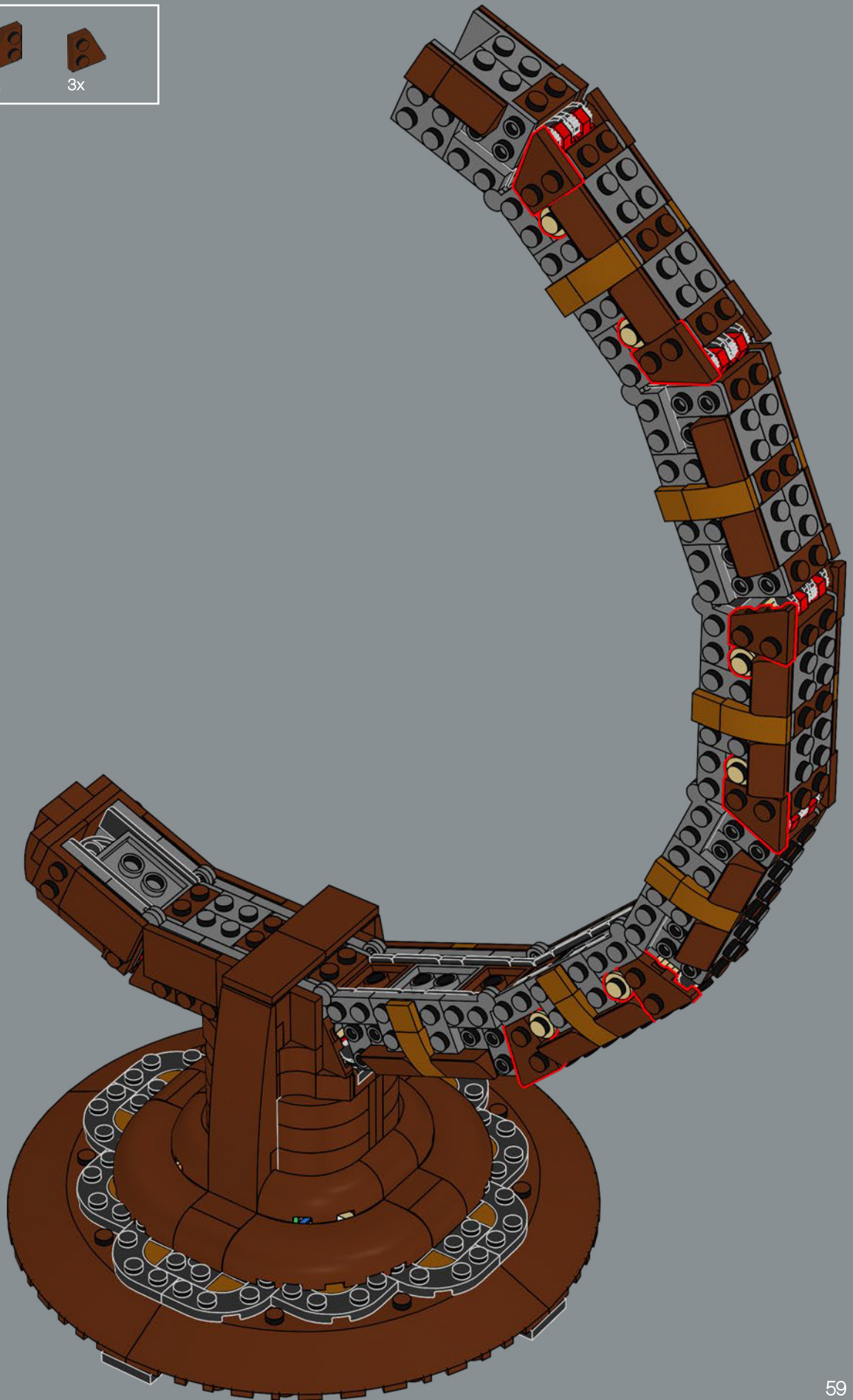



86

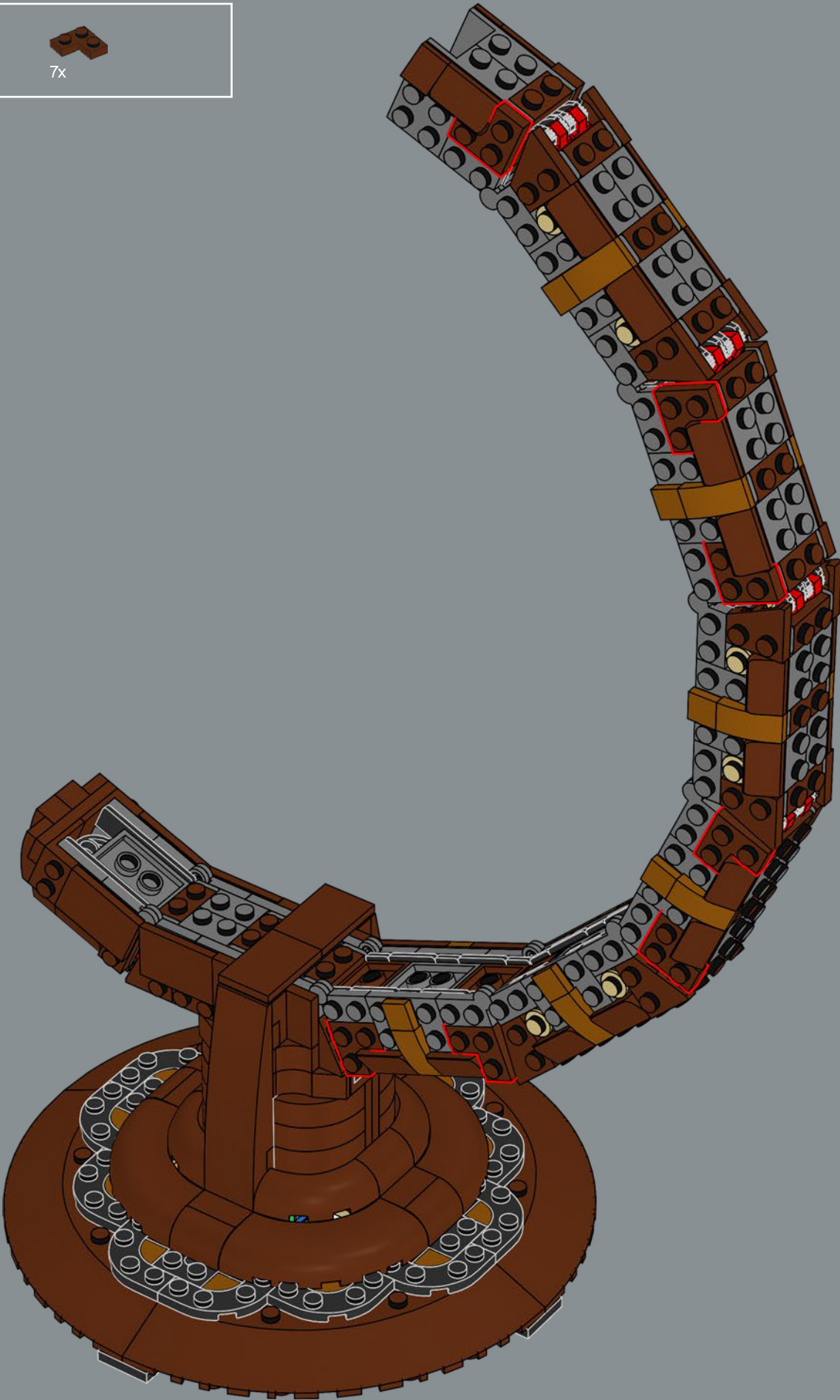



87

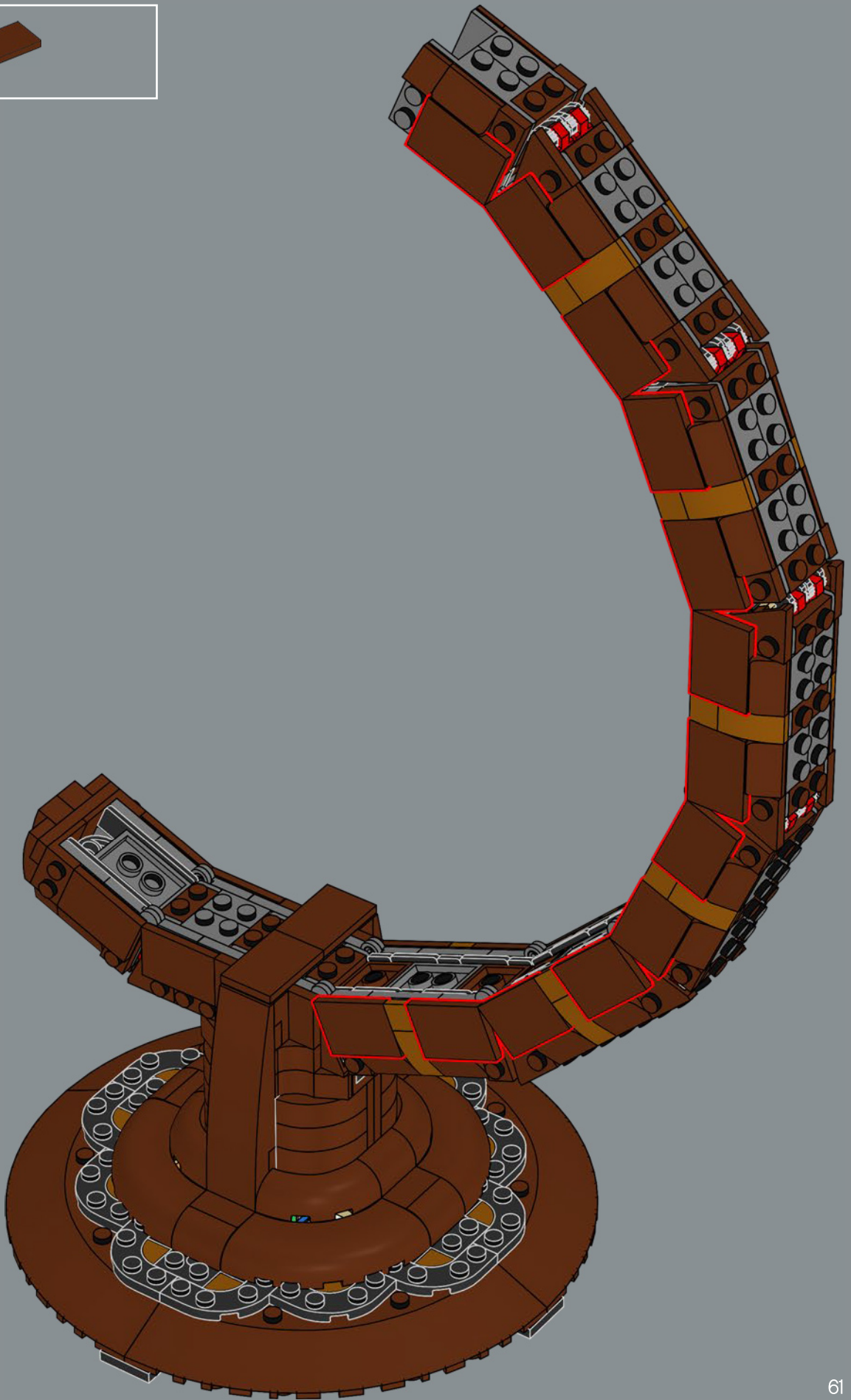

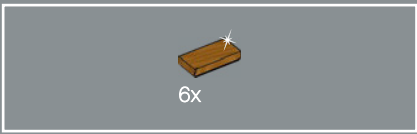

88

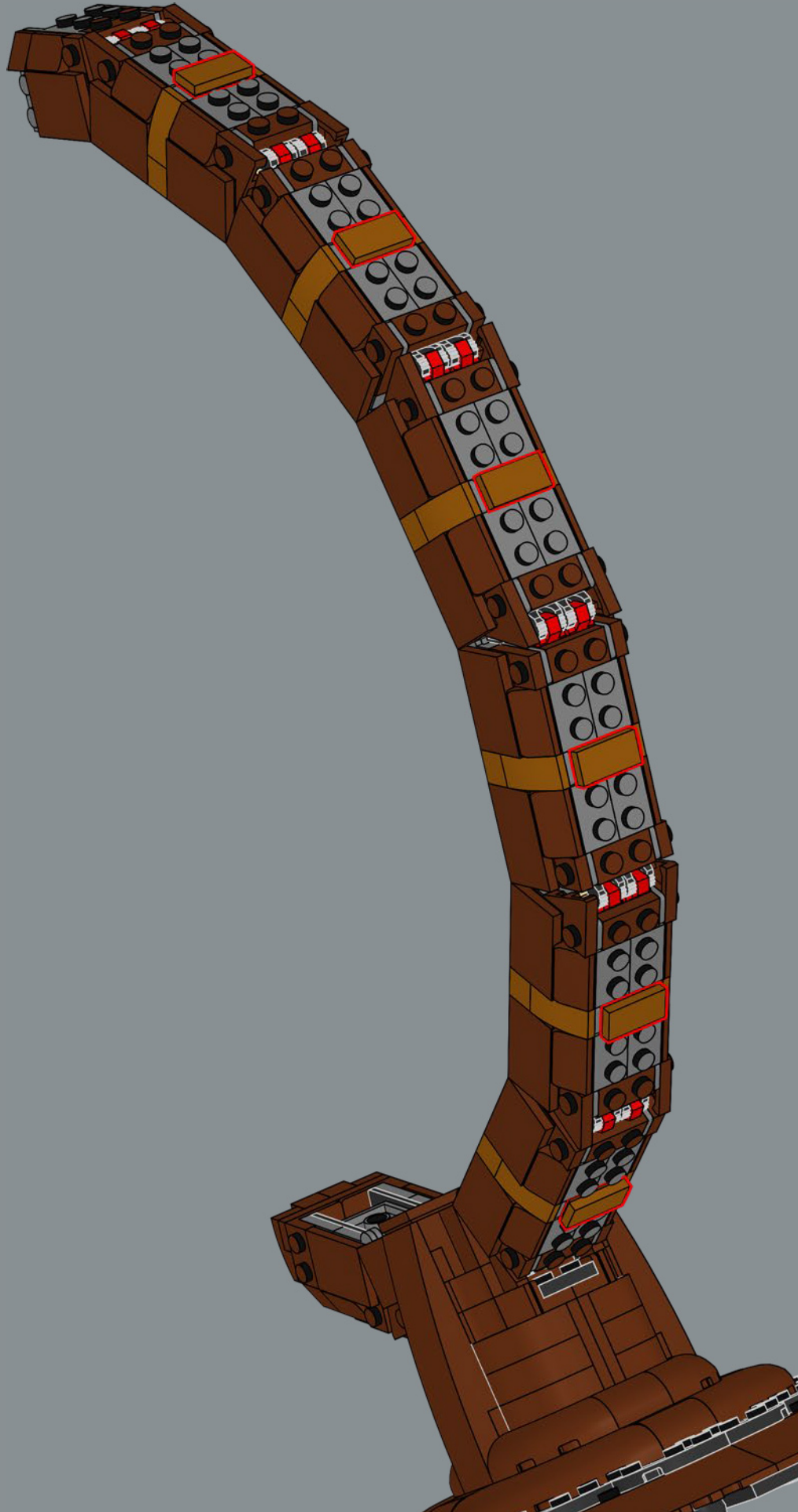

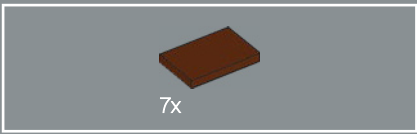

89

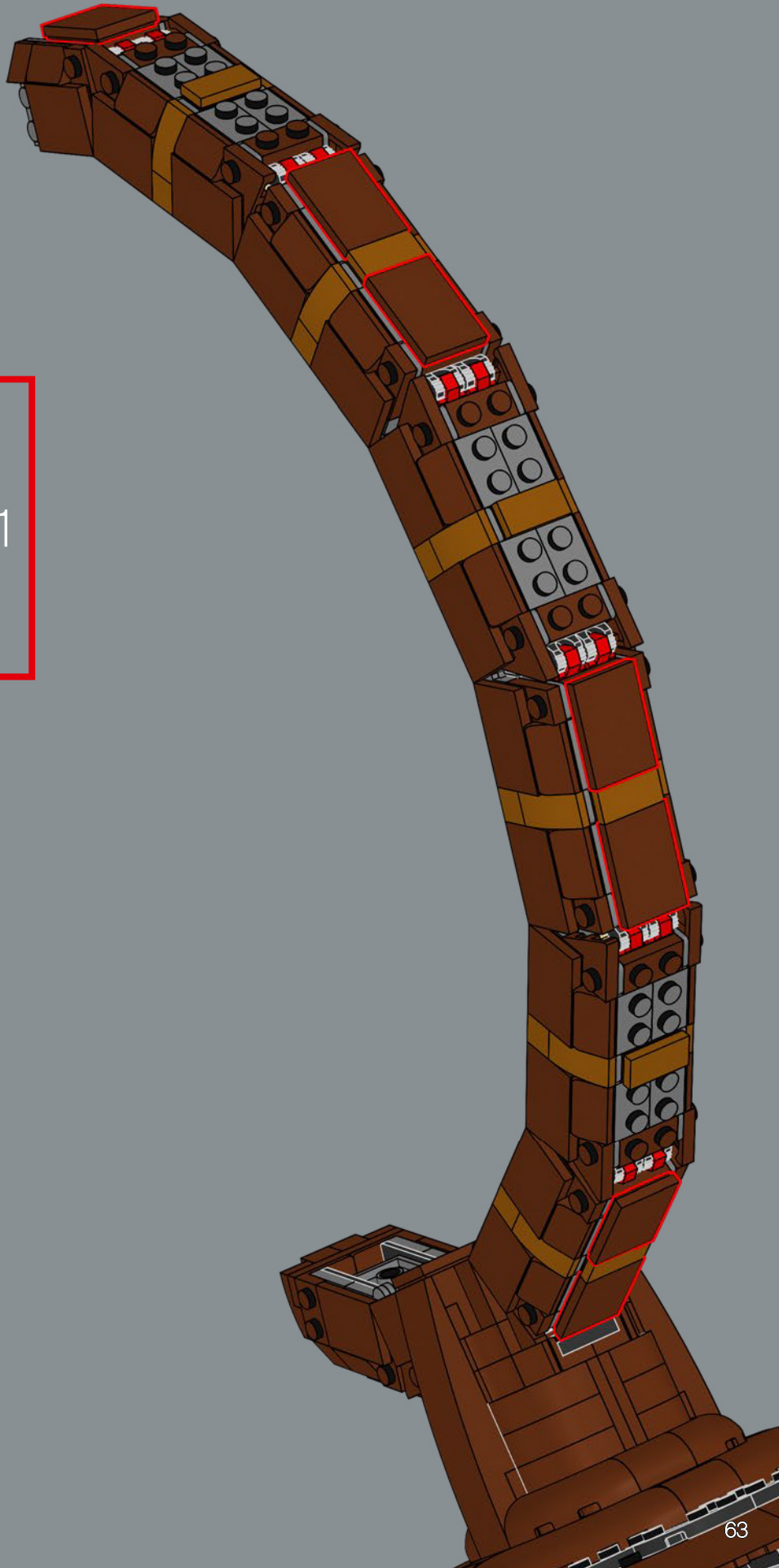
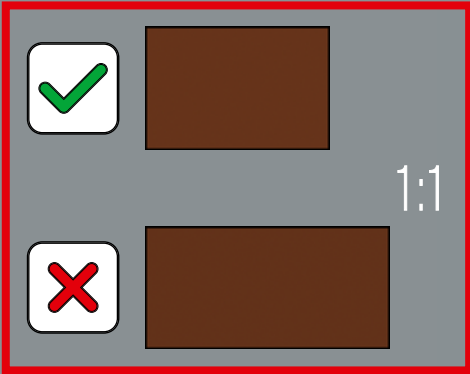



6x

90



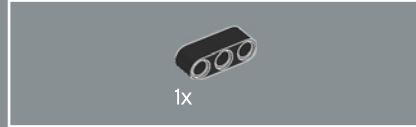
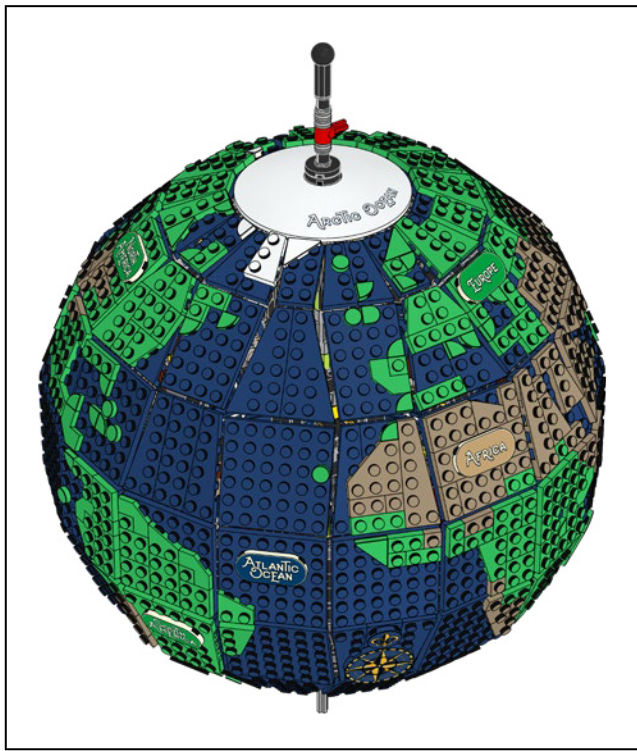
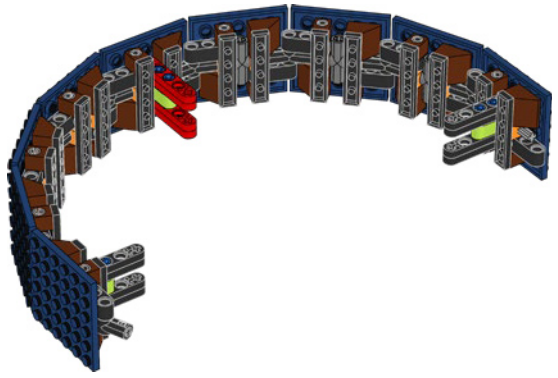

92

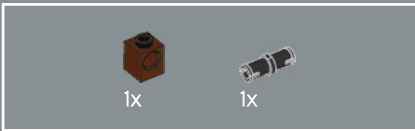
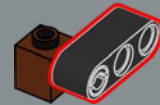

91

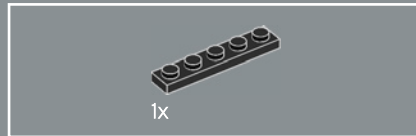

93

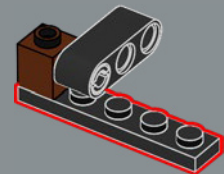
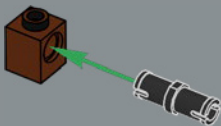

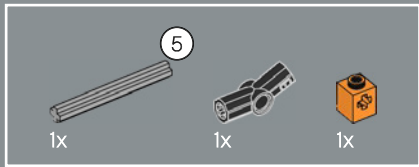

94

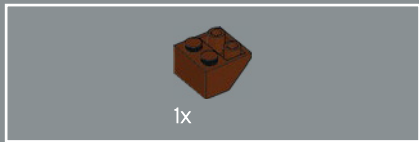
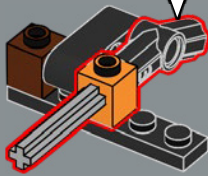
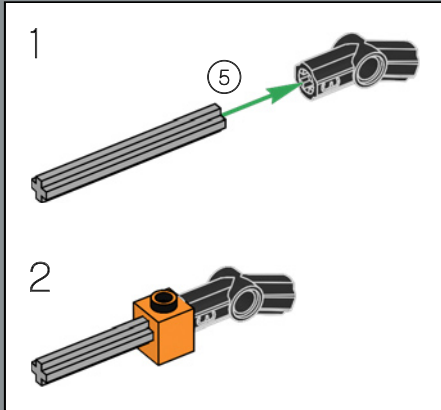

95

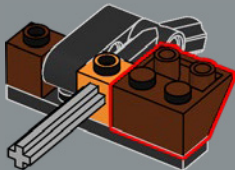

96

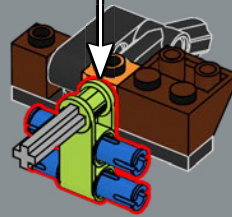
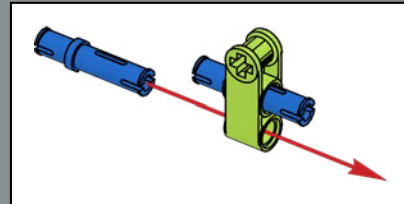

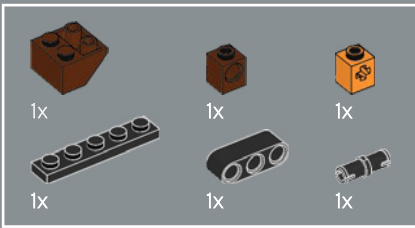

97

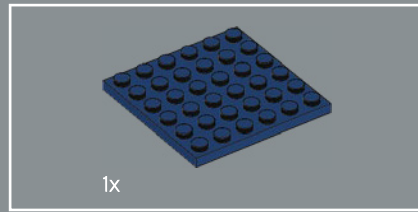
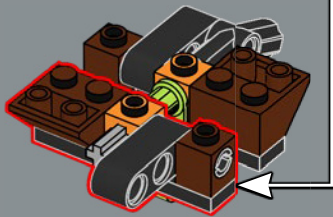
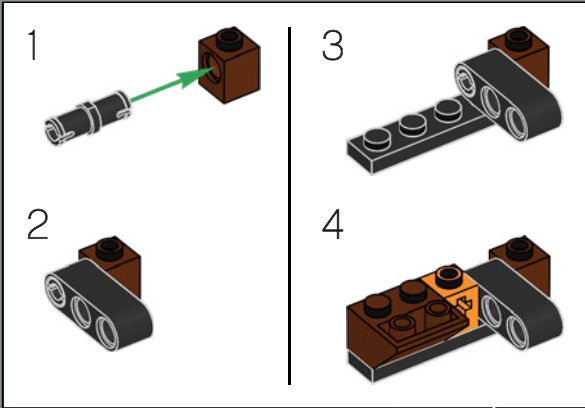

98

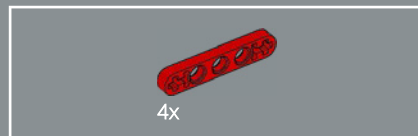
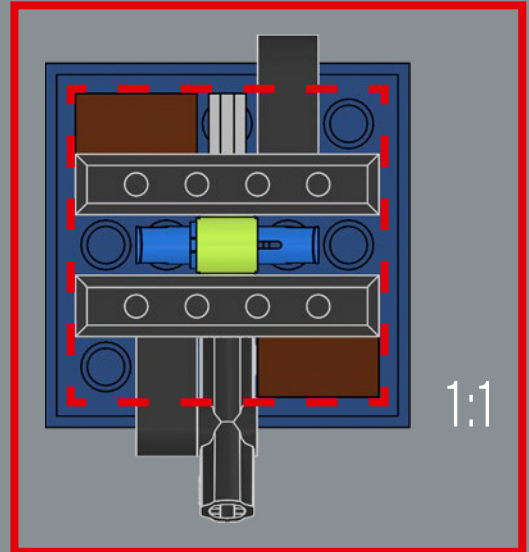
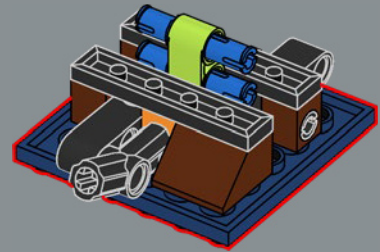

99

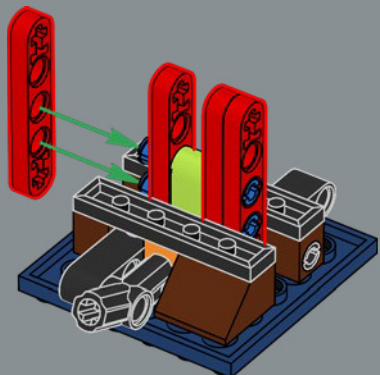

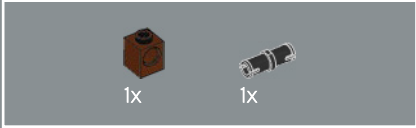
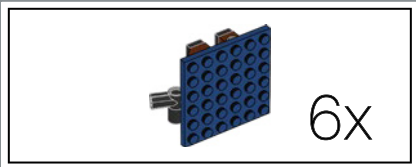

100

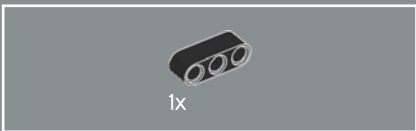
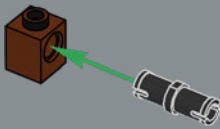

101

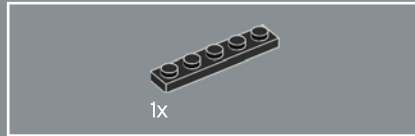
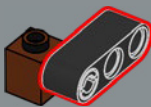

102

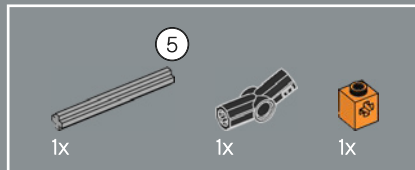
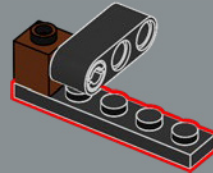

103

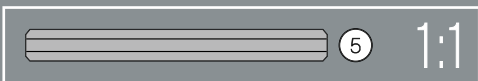
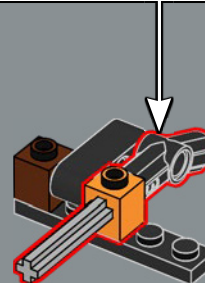
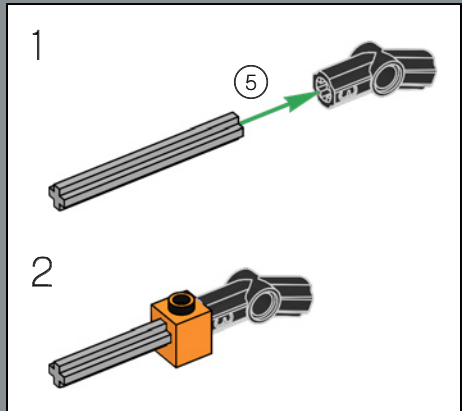

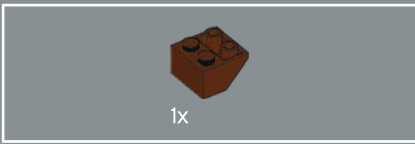

104

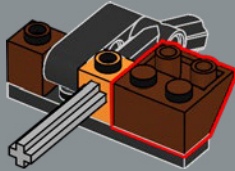

105

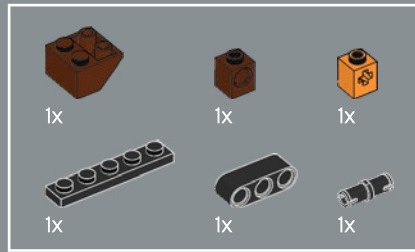
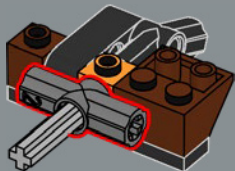

106

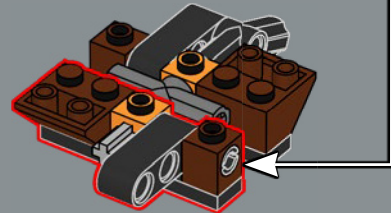
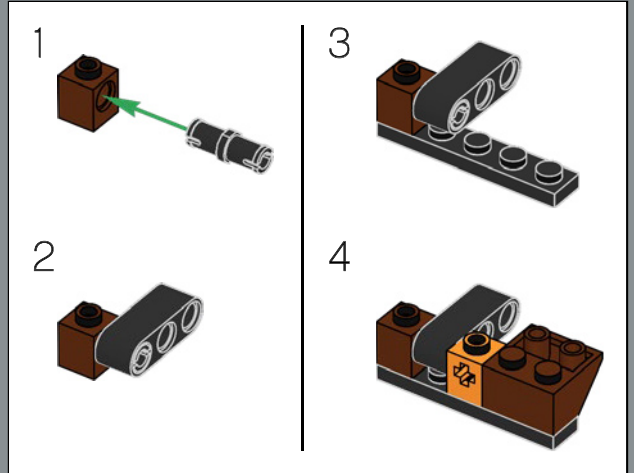

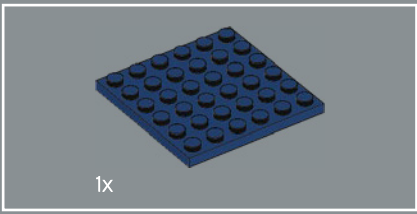

107

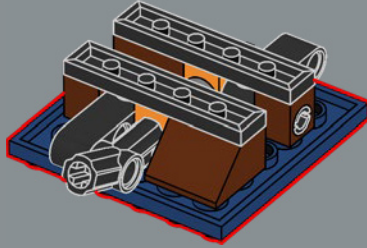

6x

108

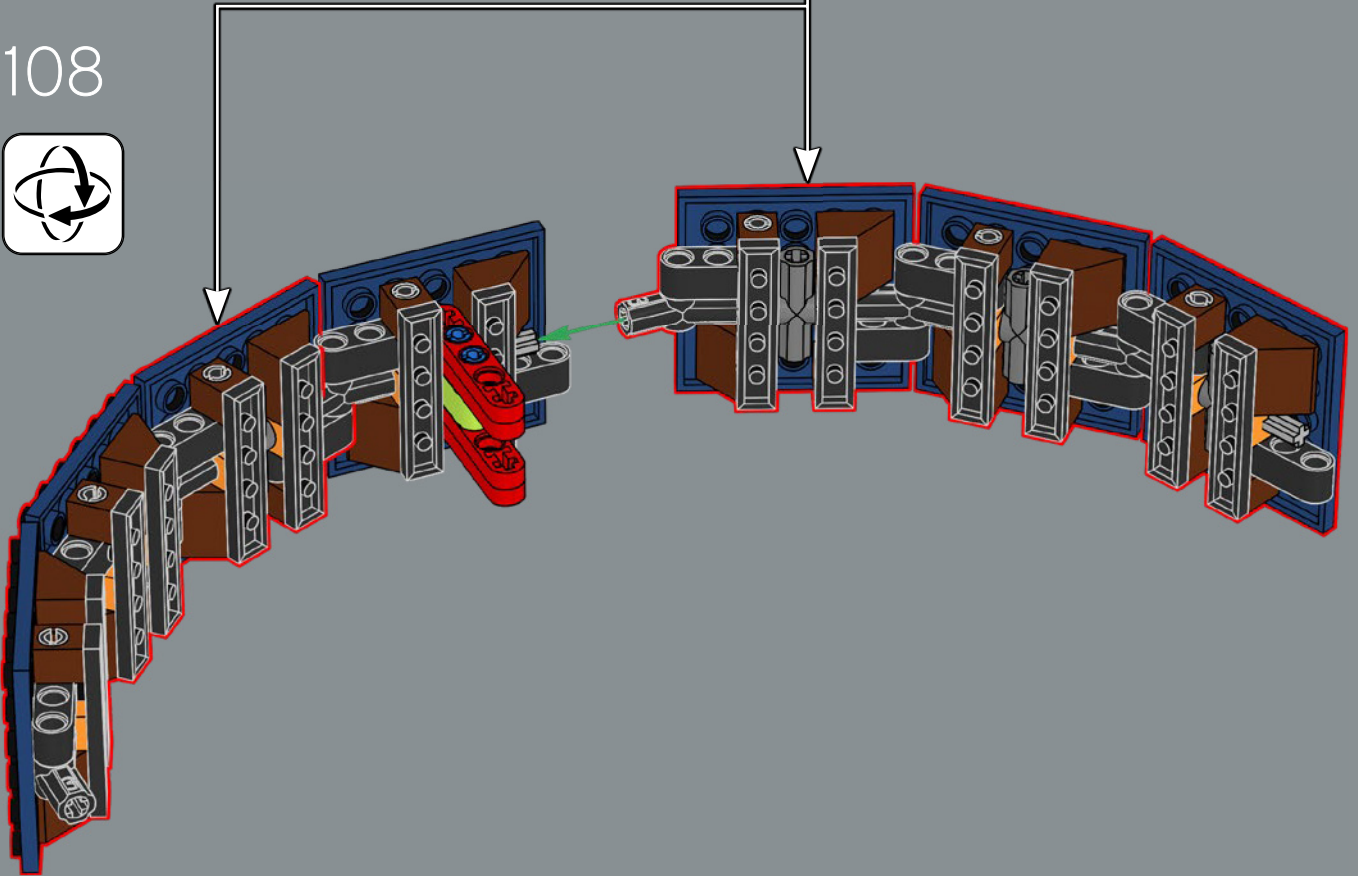

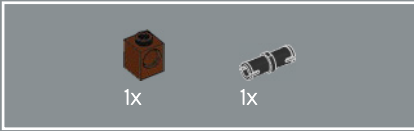
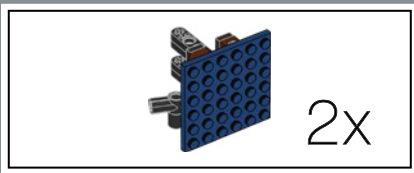

109

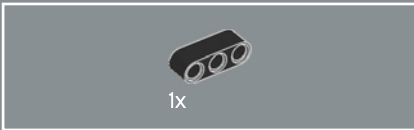
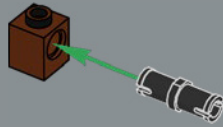

110

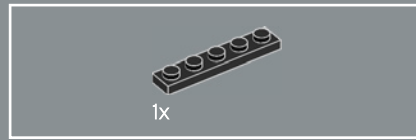
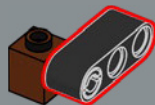

111

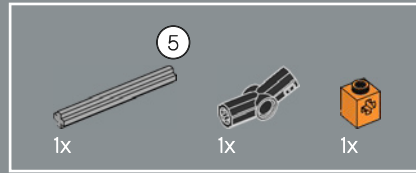
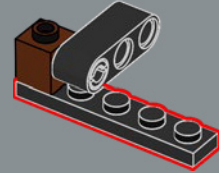

112

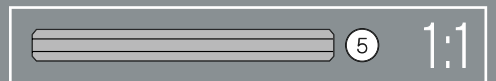
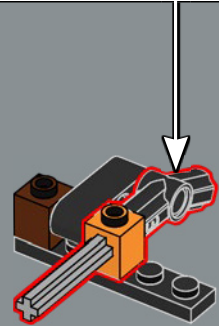
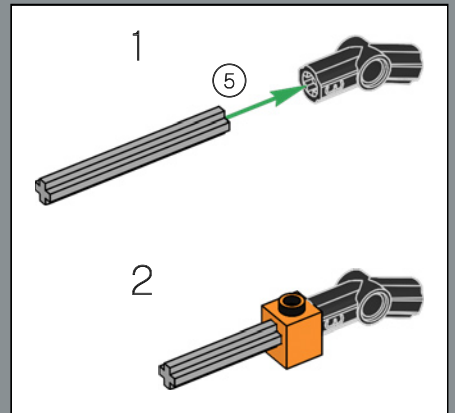

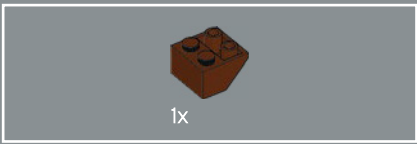

113

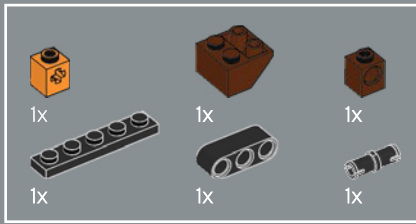
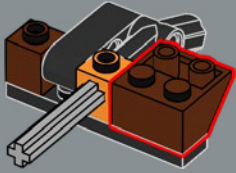

115

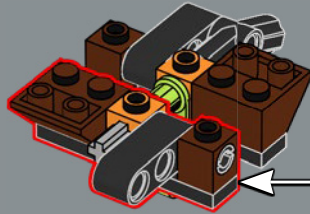
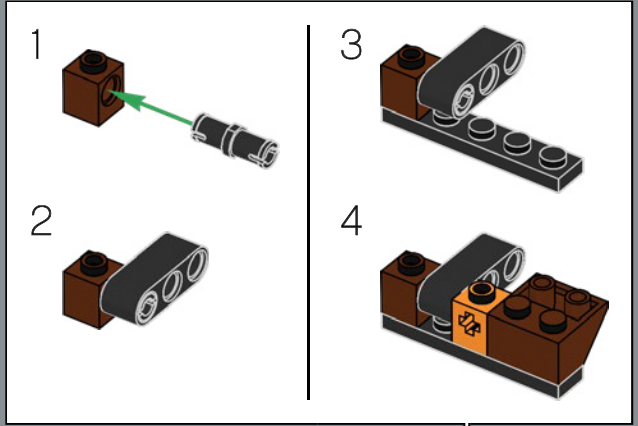

114

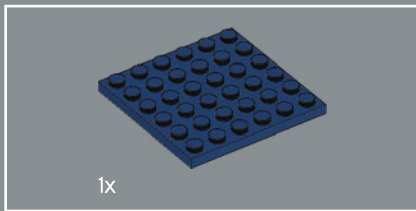
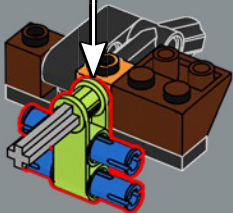
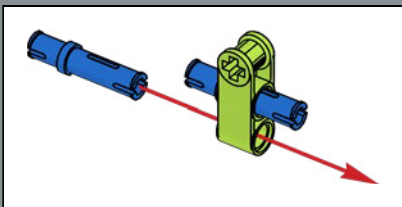

116

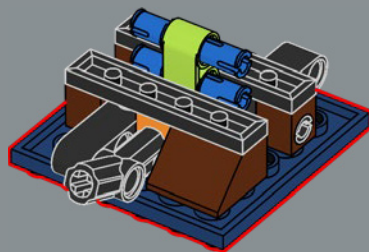



117

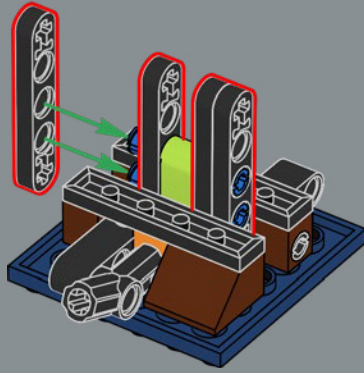

2x

118

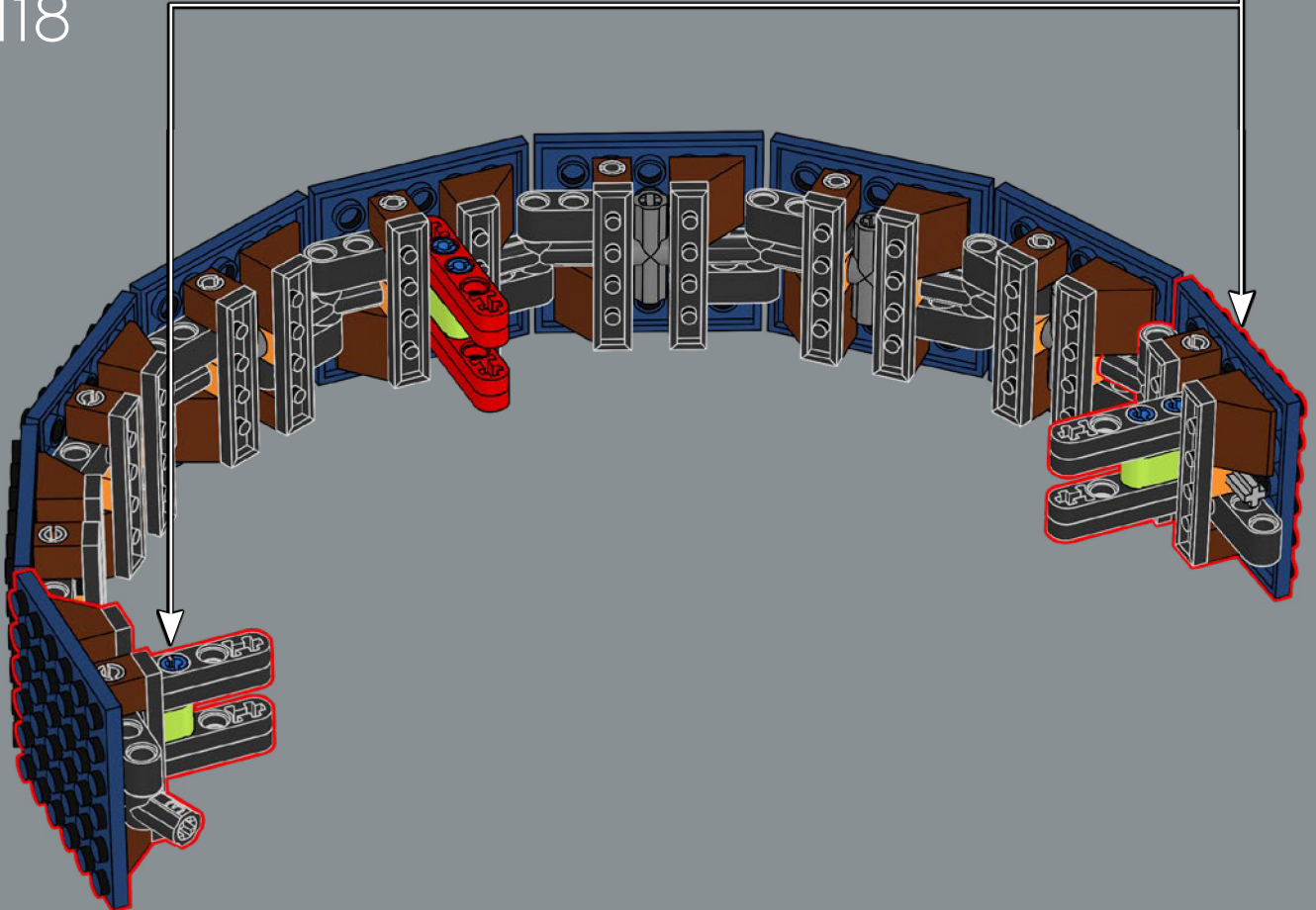

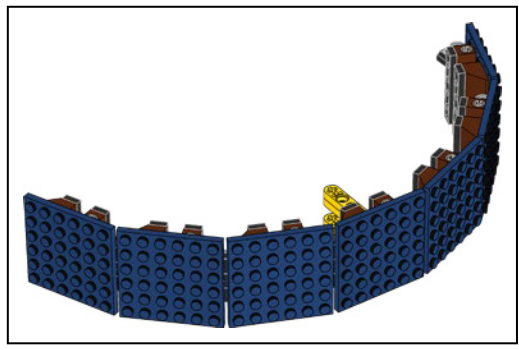
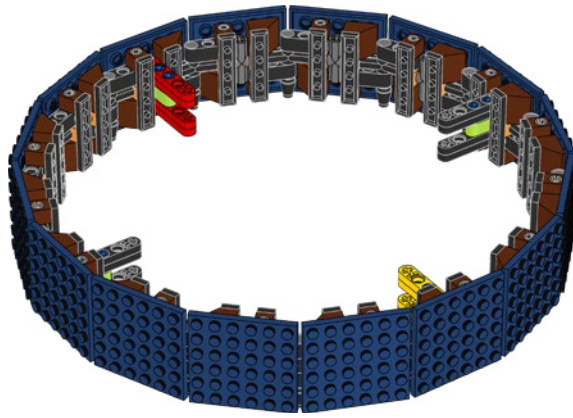

1x



1x

119

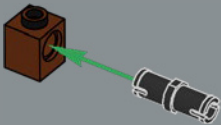

1x

120

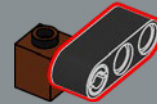

1x

121

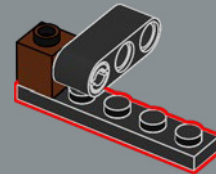

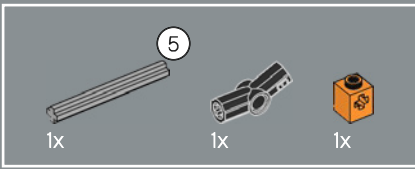

122

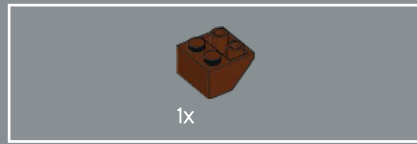
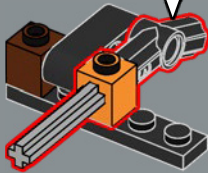
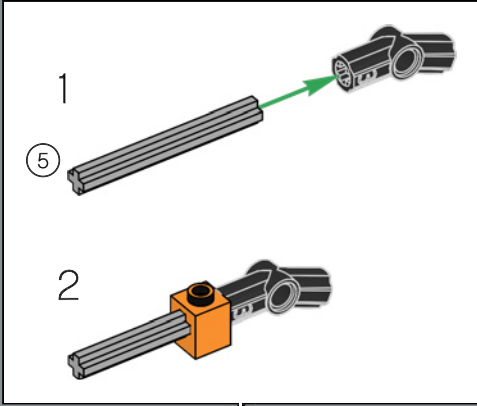

123

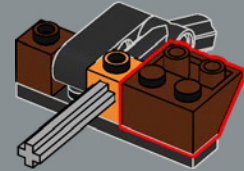

124

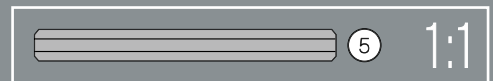
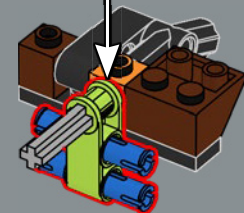
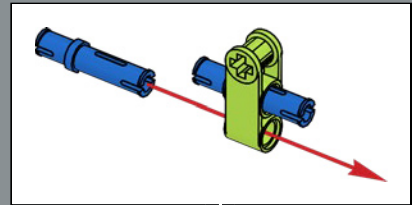

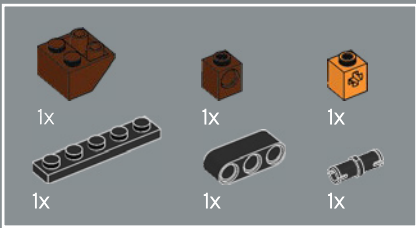

125

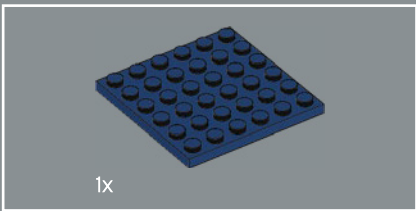
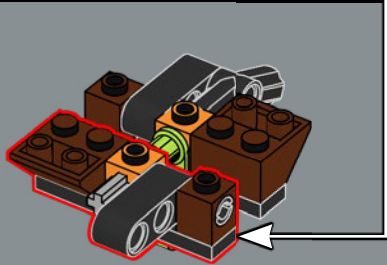
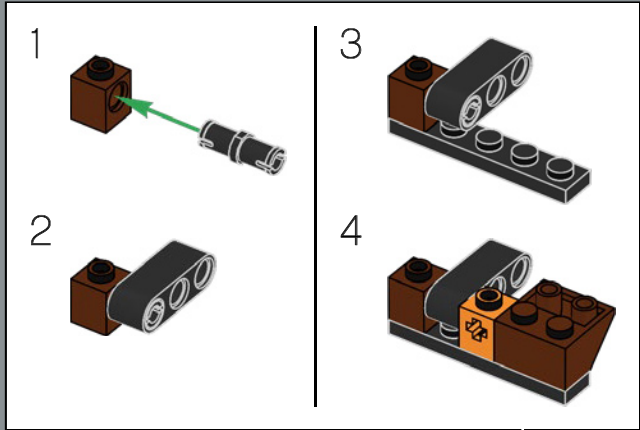

126

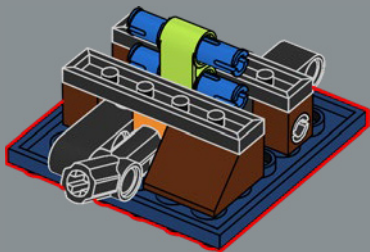

127

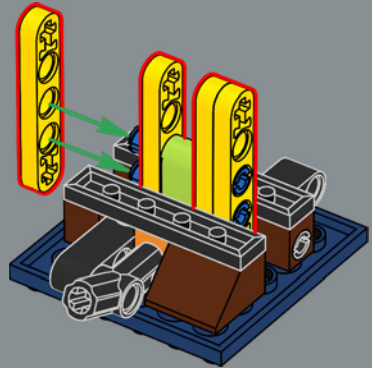

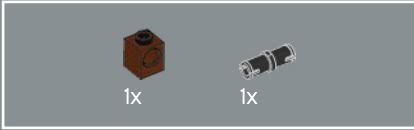
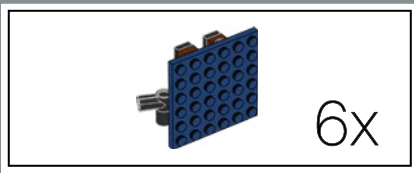

128

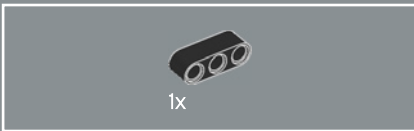
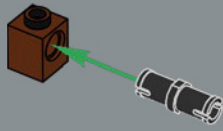

129

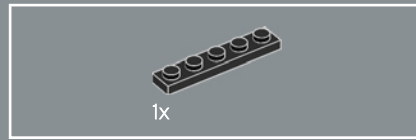
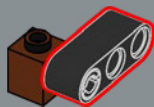

130

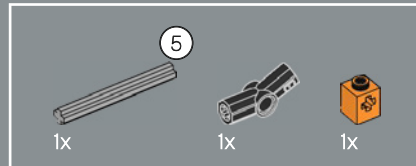
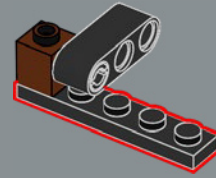

131

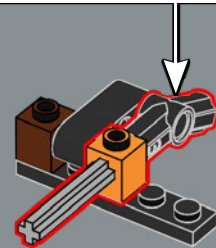
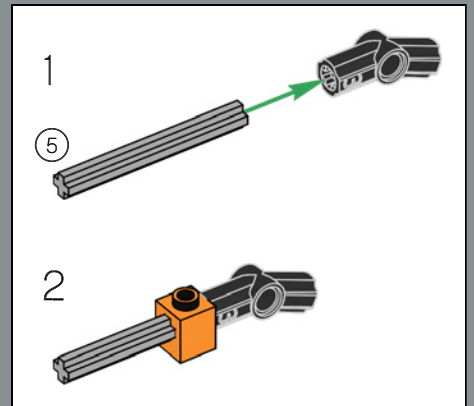

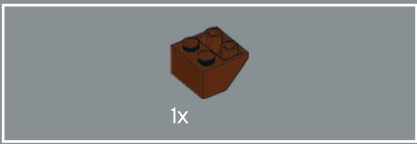

132

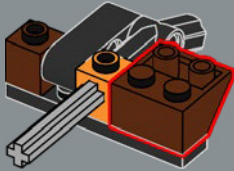

133

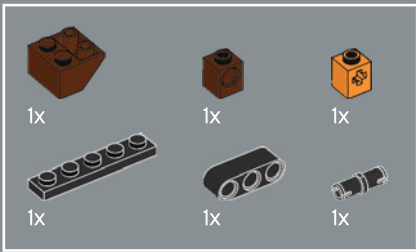
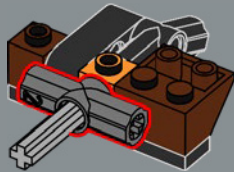

134

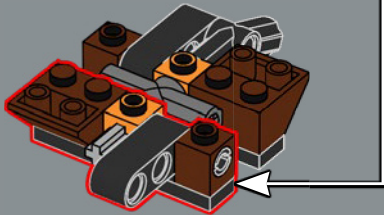
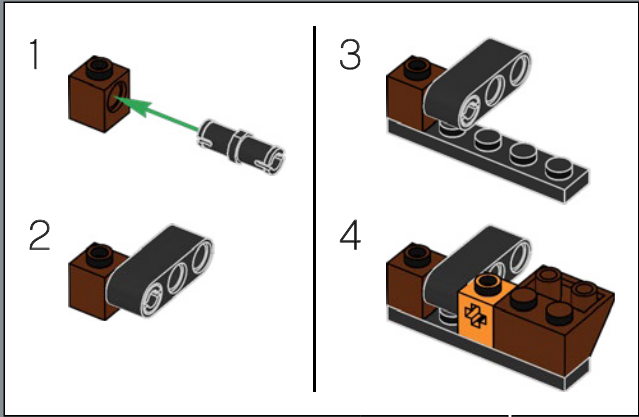

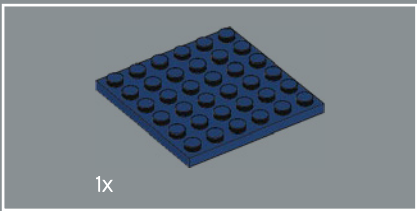

135

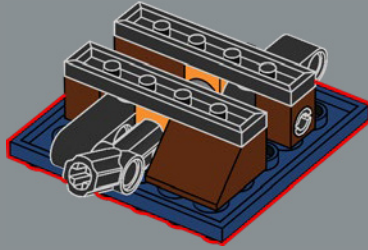

6x

136

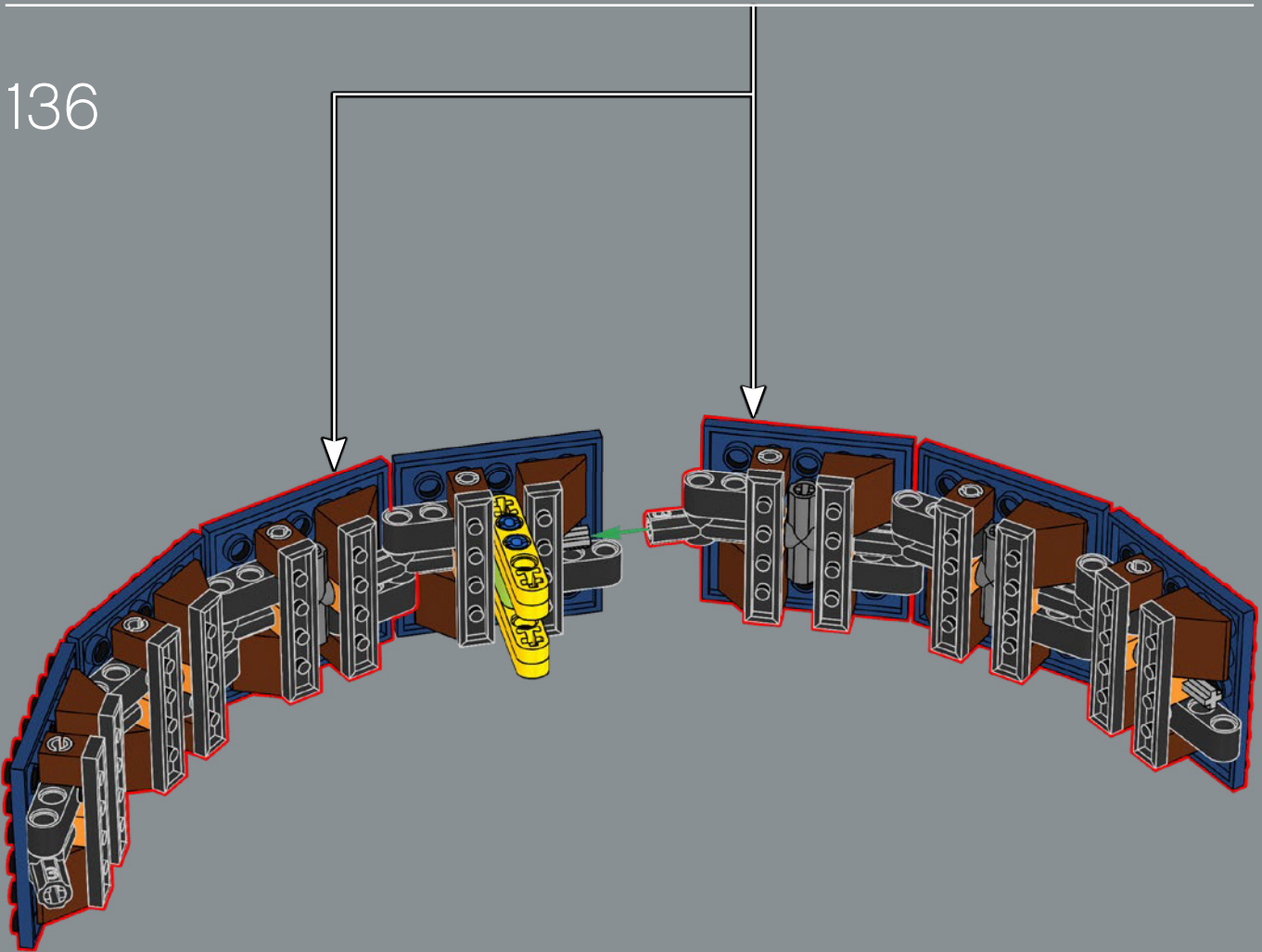

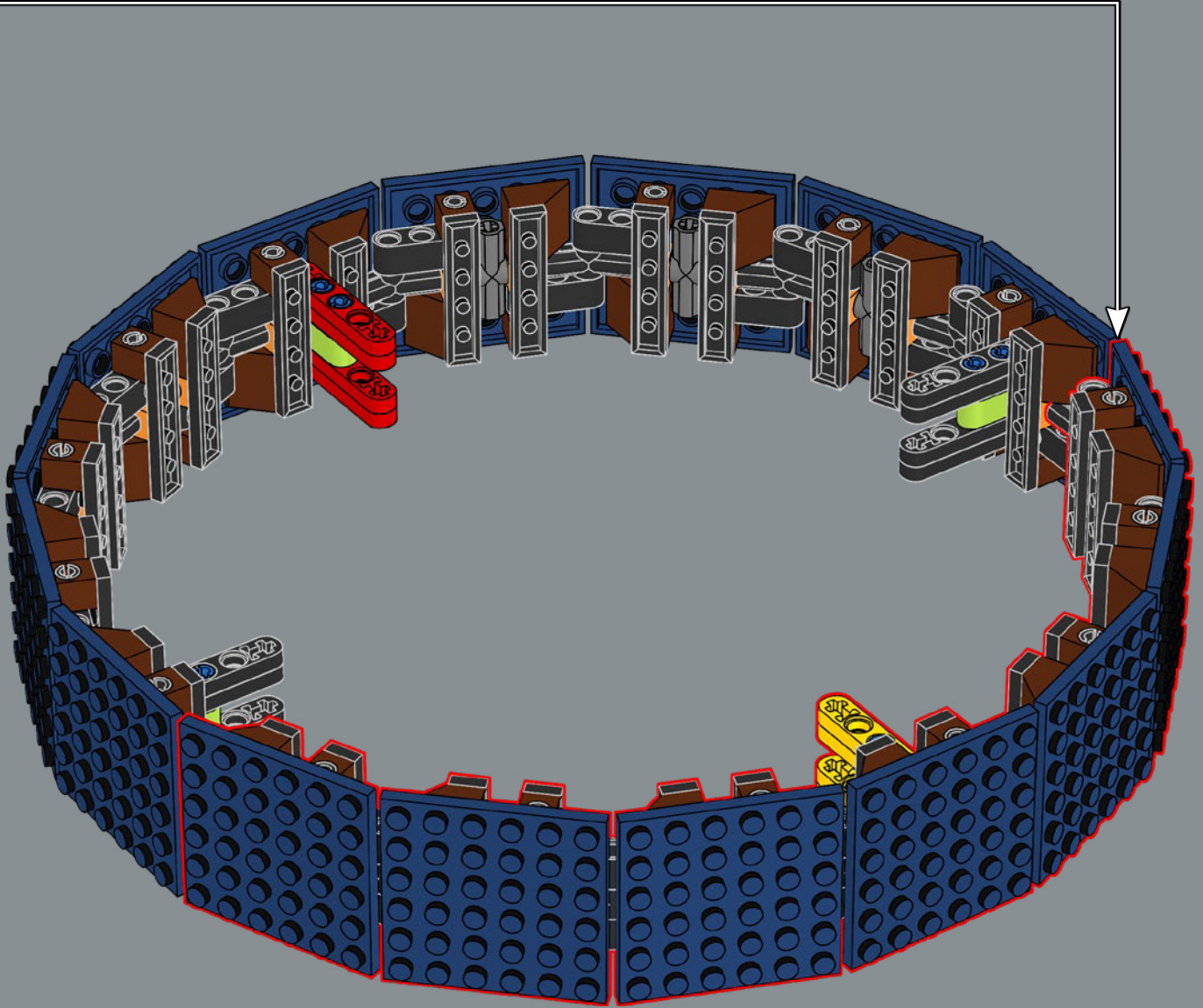

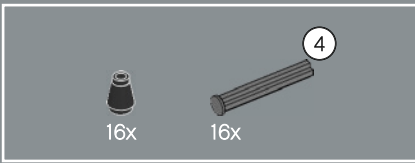

138

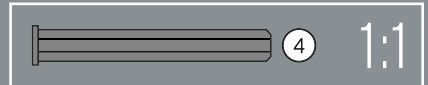
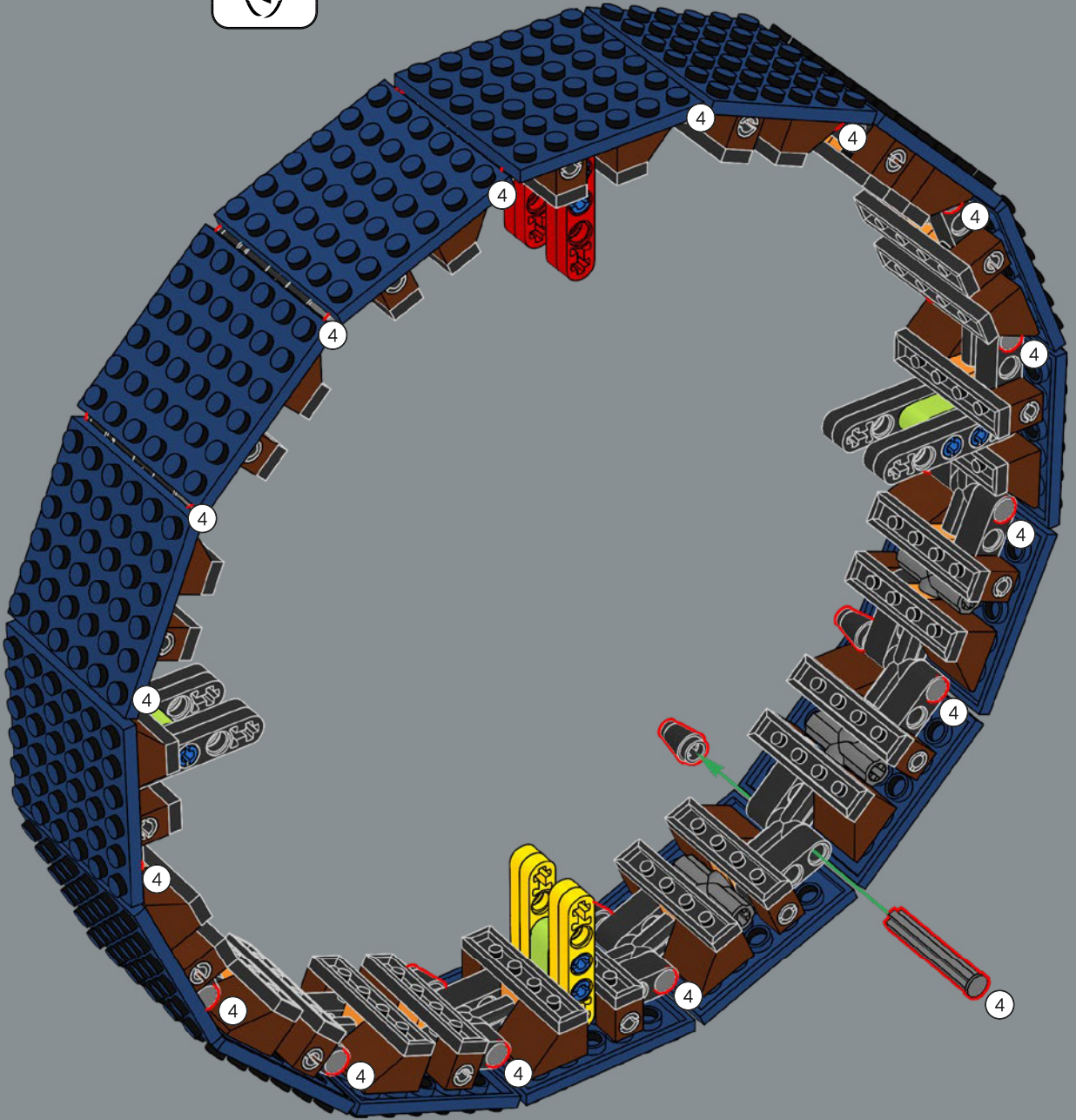

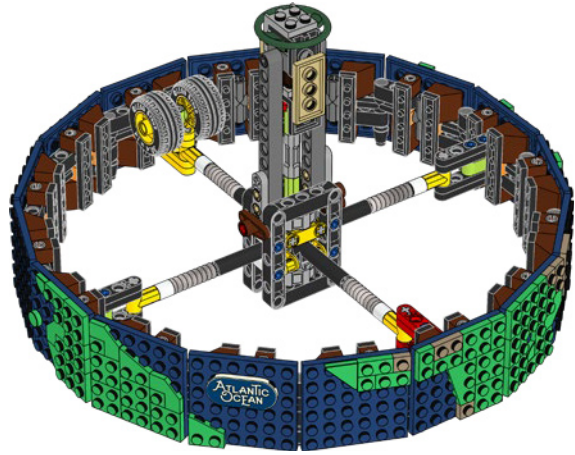

1x



3x



1x

139

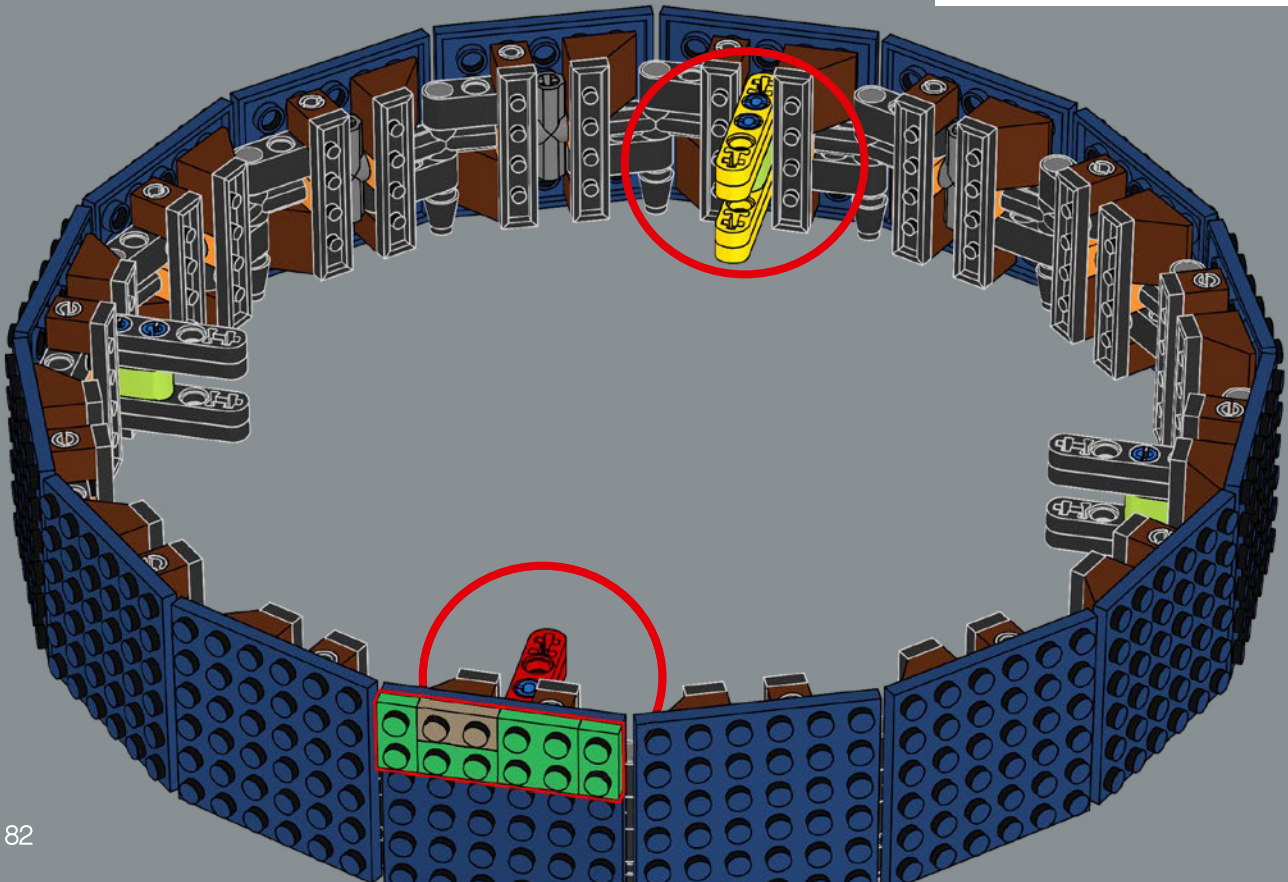

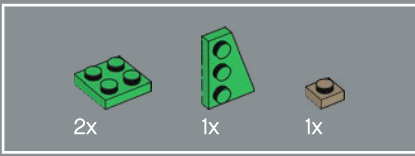

140

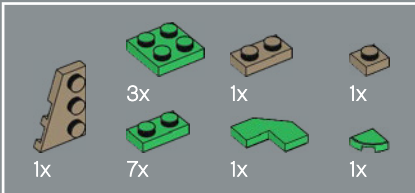
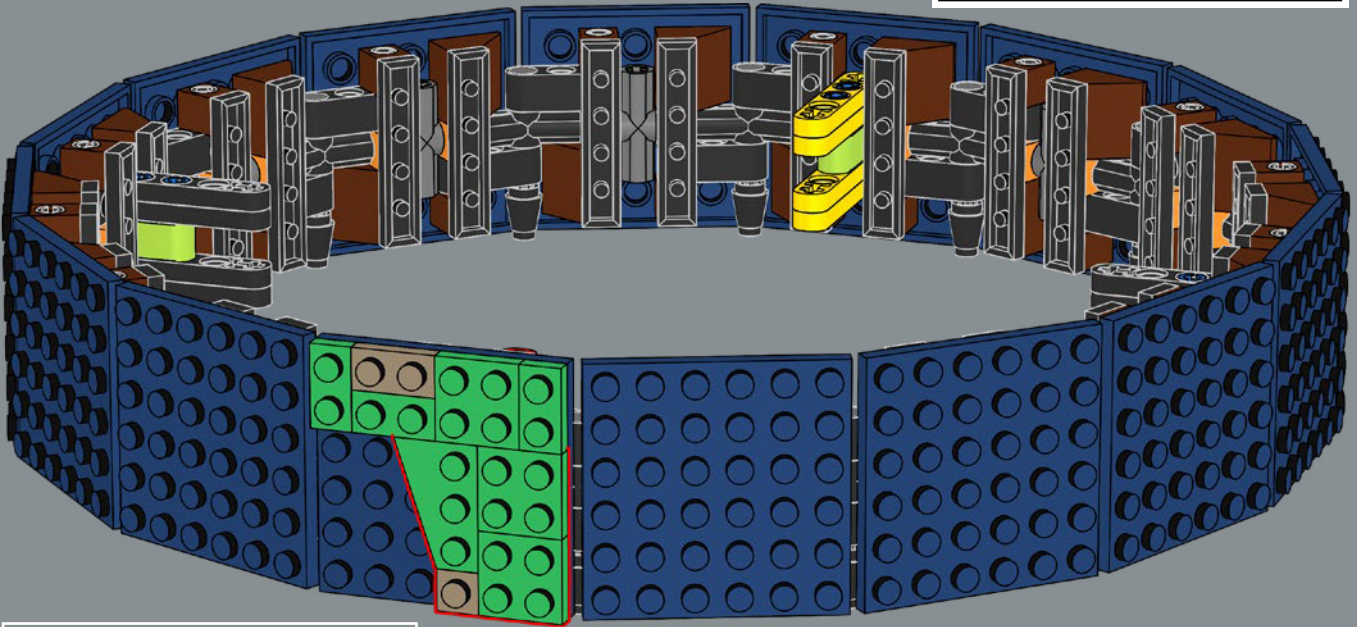

141

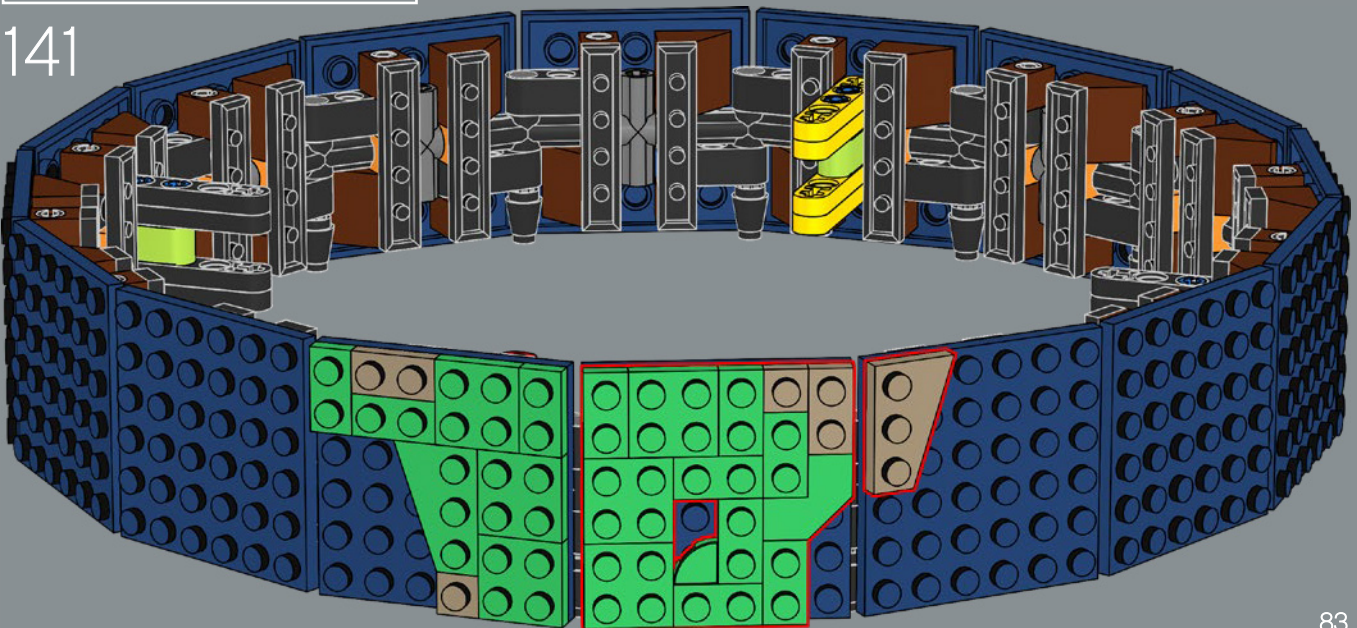



142

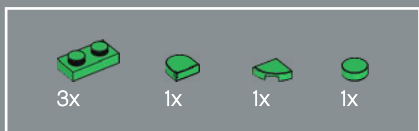
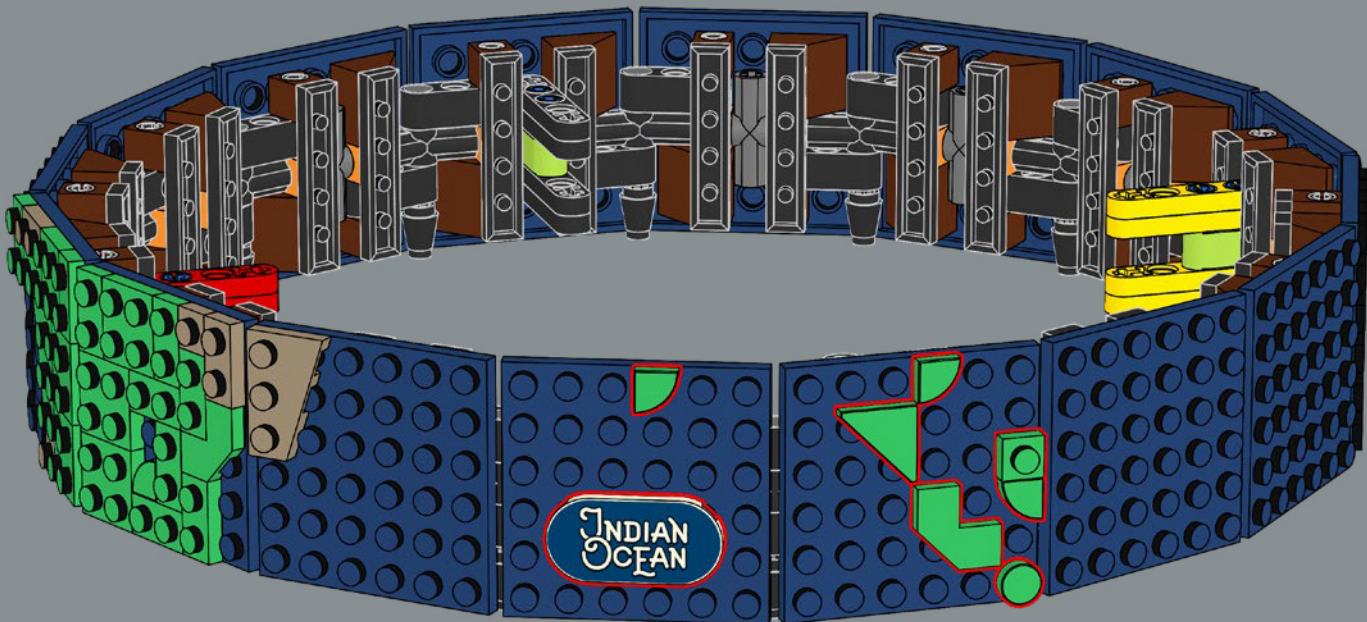
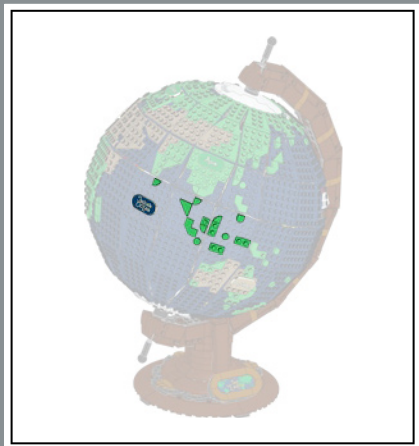

143

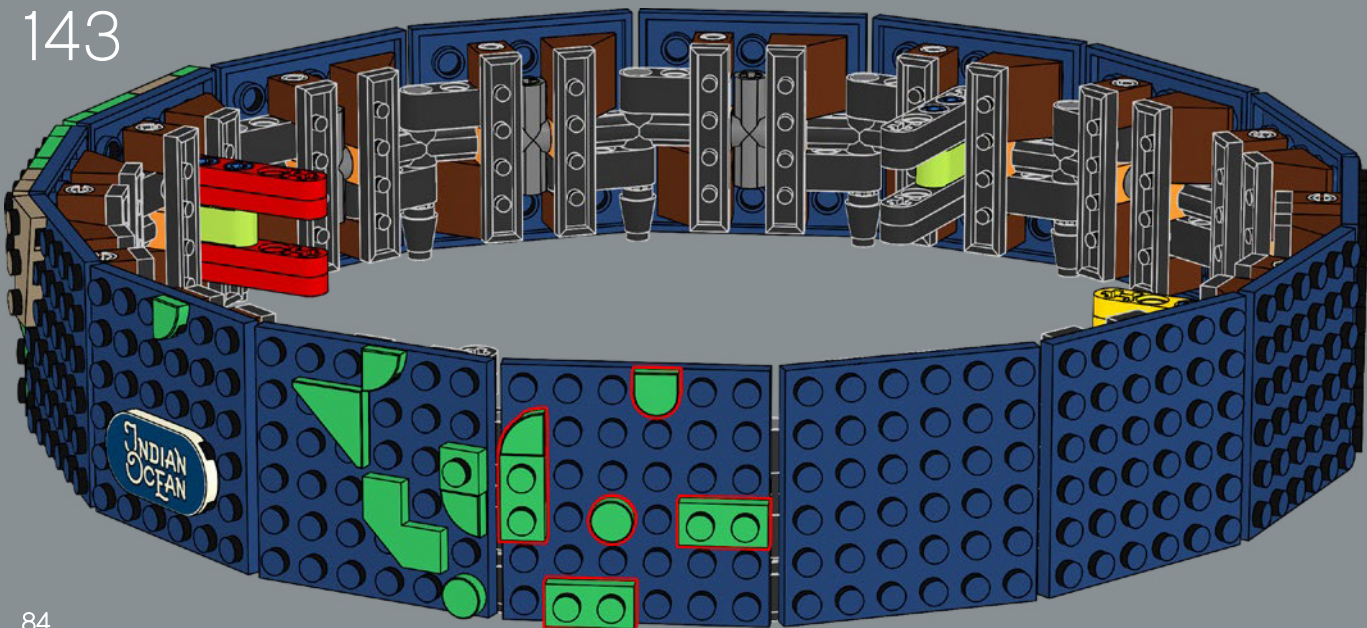

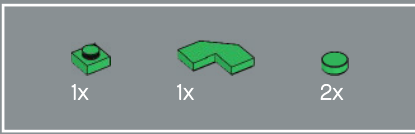

144

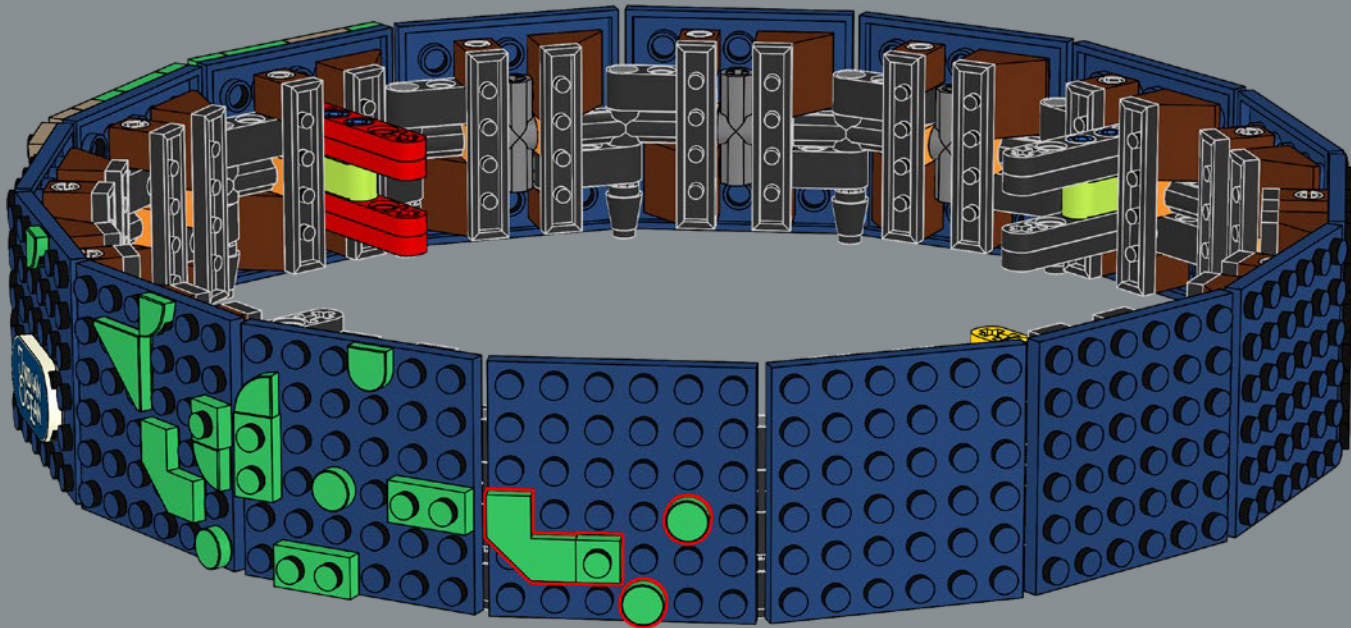

145

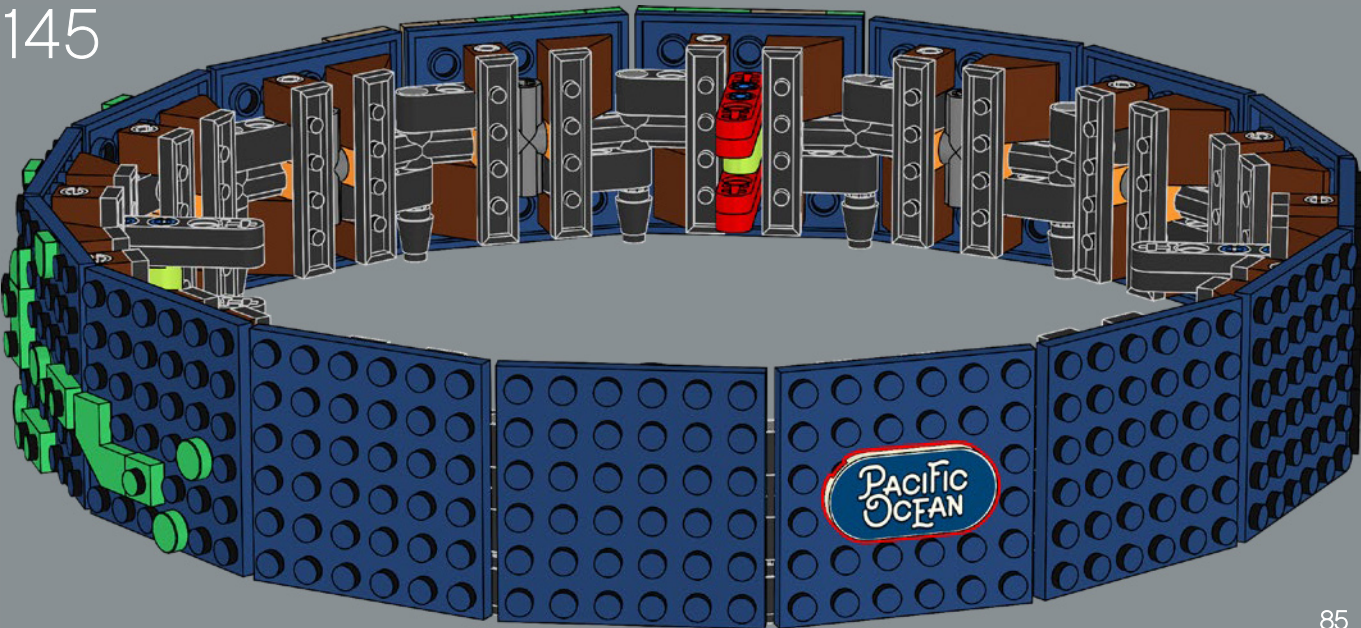

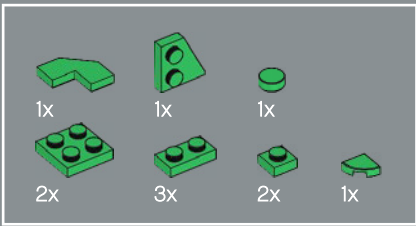

146

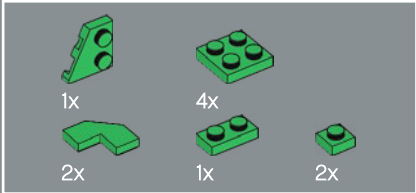
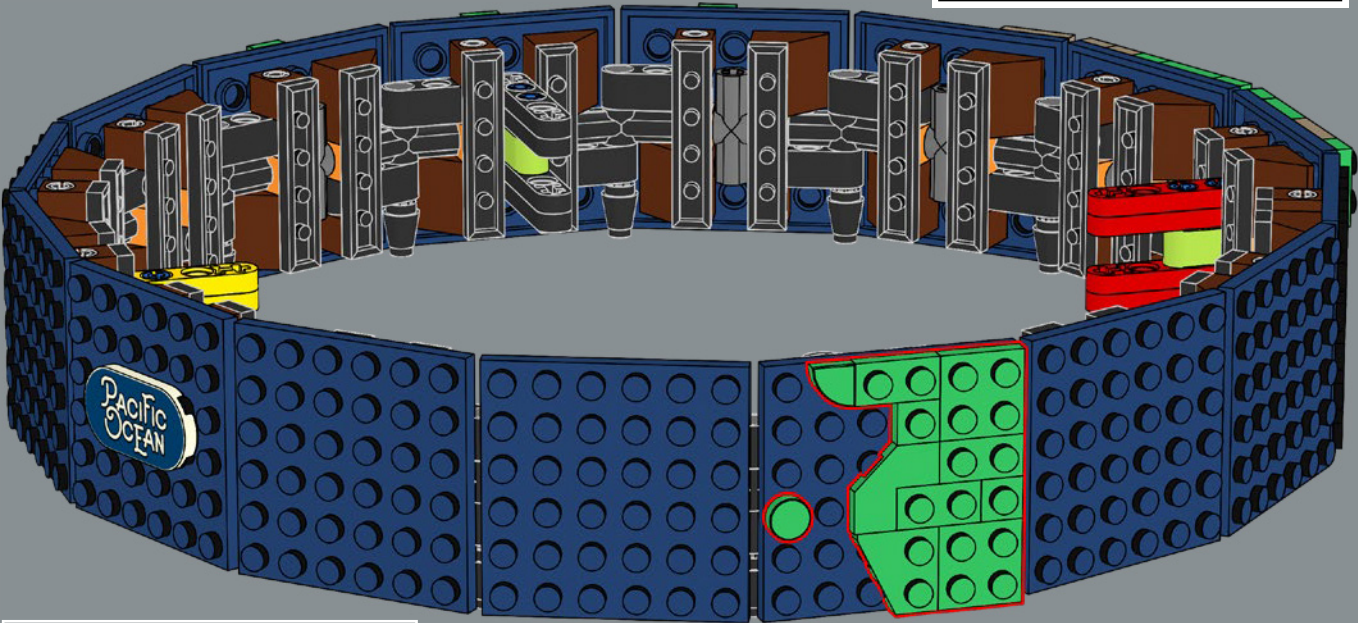

147

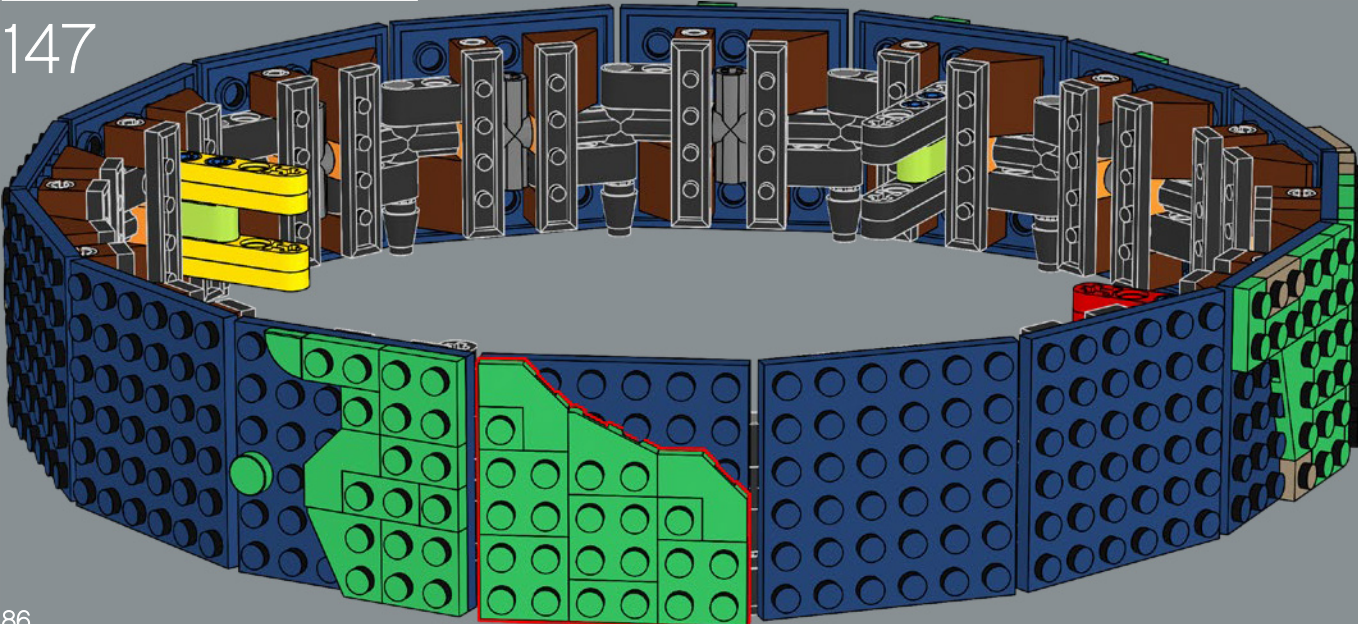

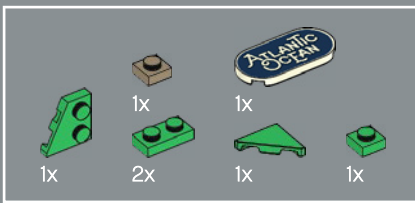

148

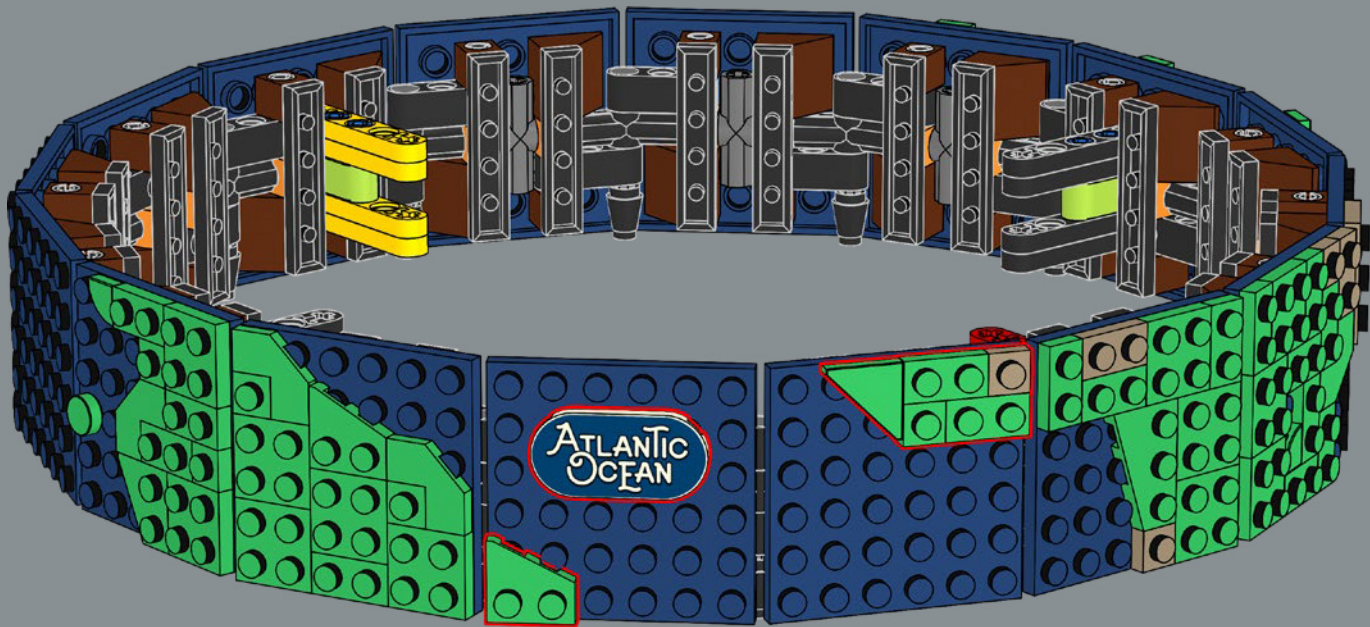

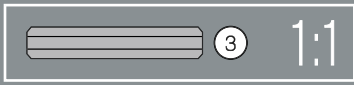
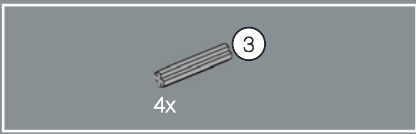

149

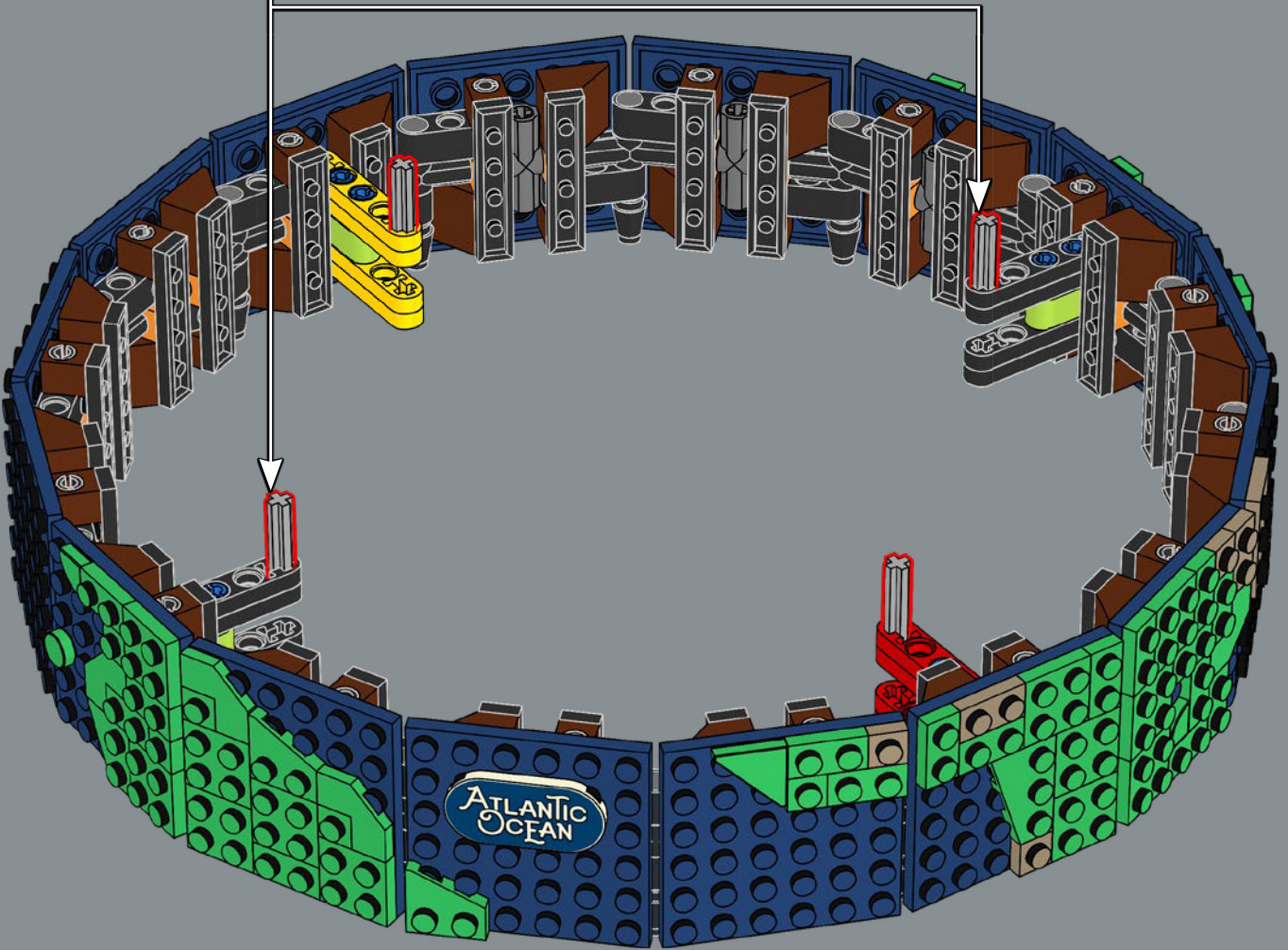
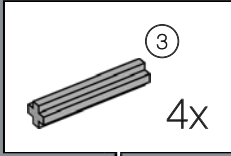

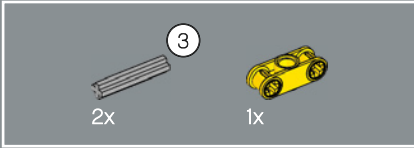
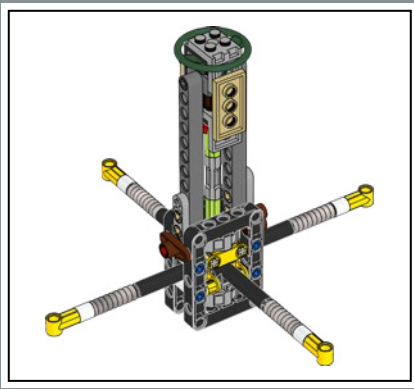

150

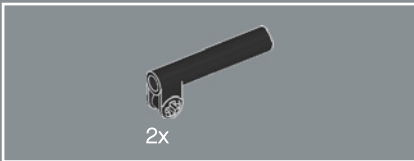
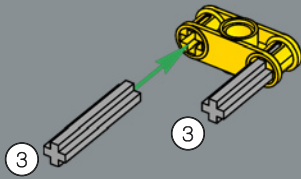

151

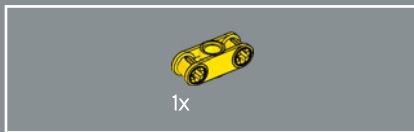
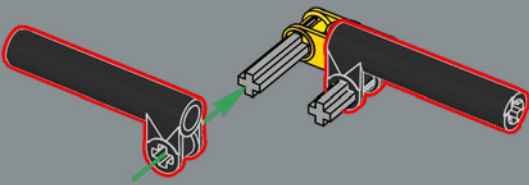

152

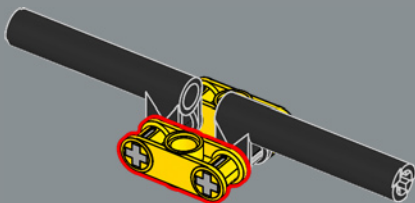

153

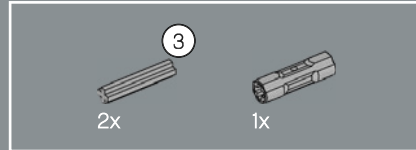
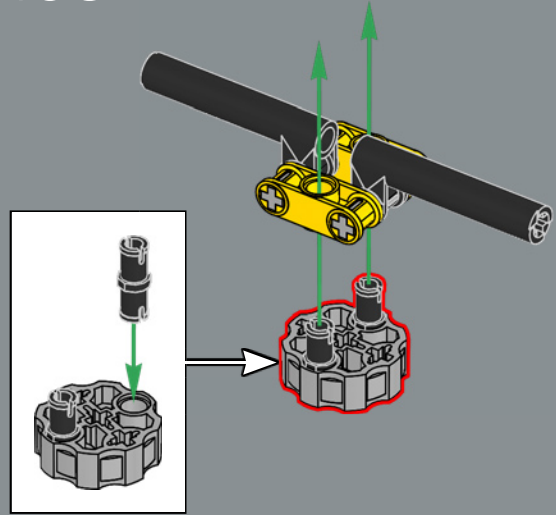

154

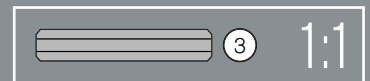
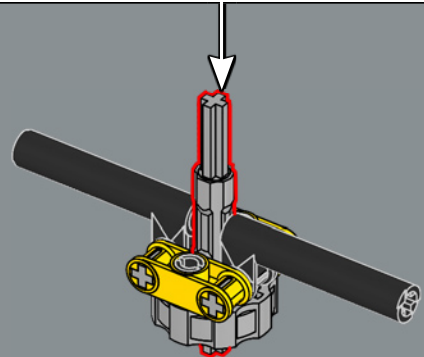
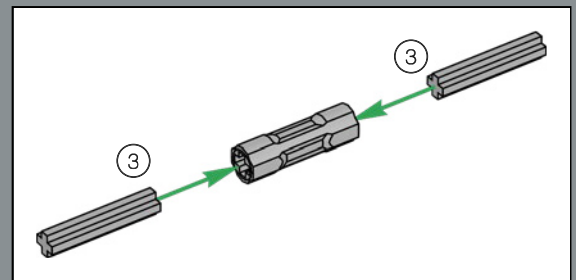

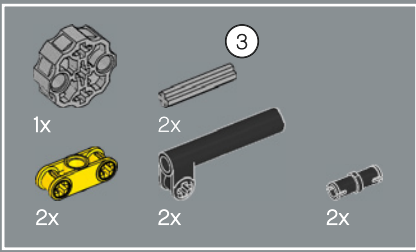

155

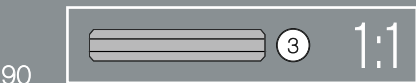
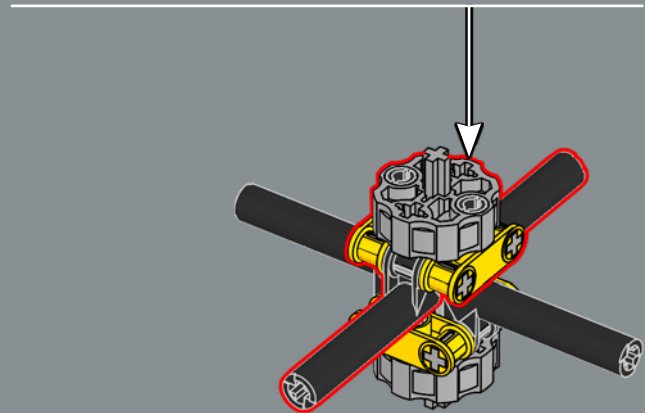
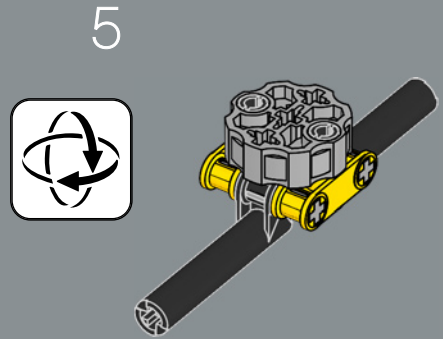
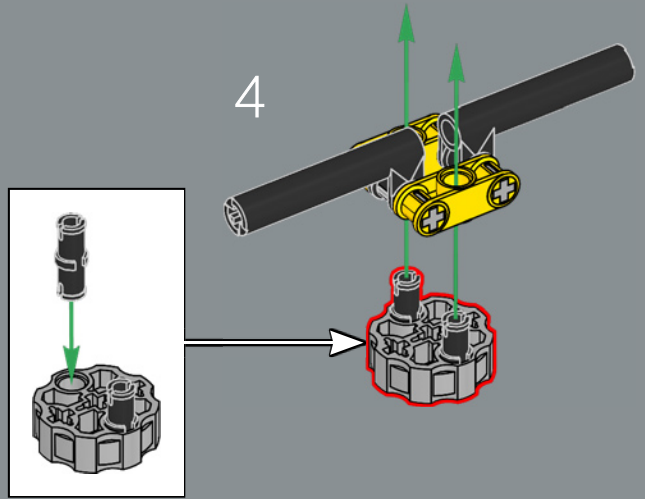
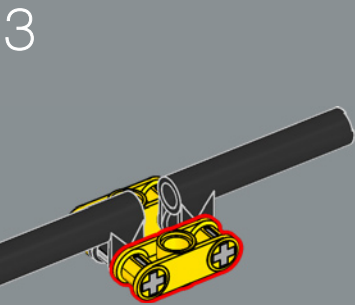
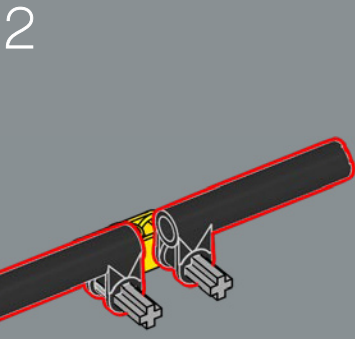
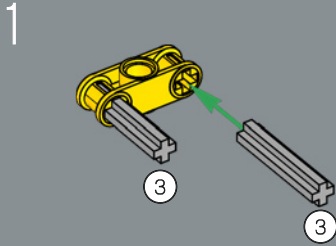

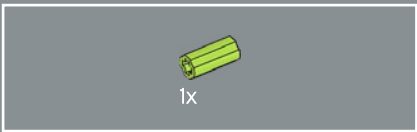

156

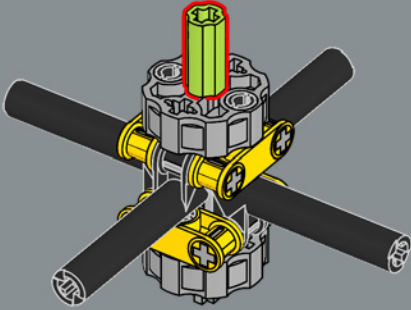

157

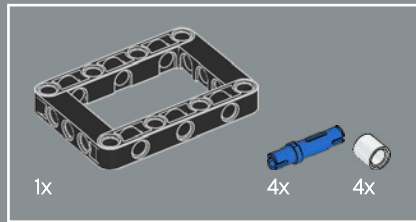
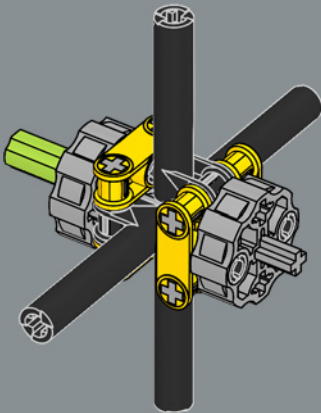

158

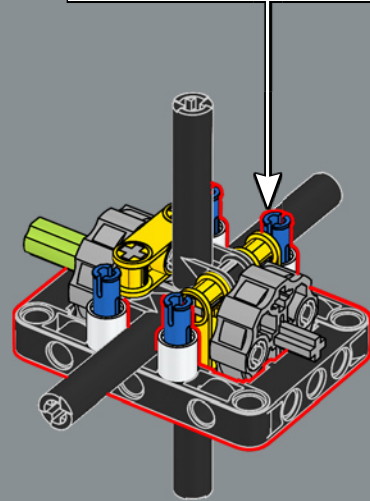
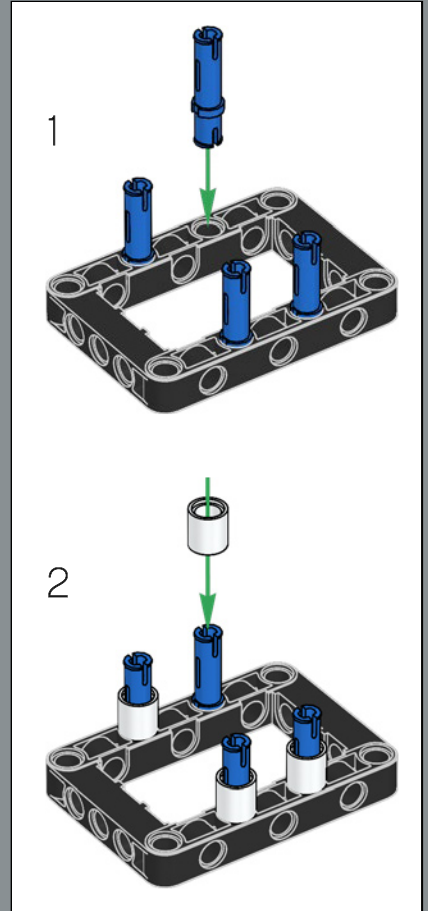

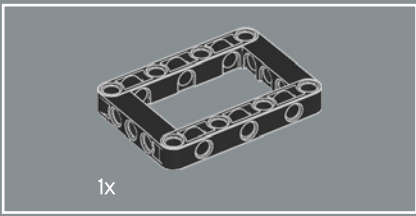

159

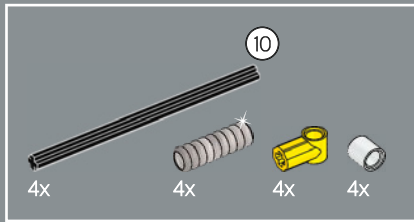

160

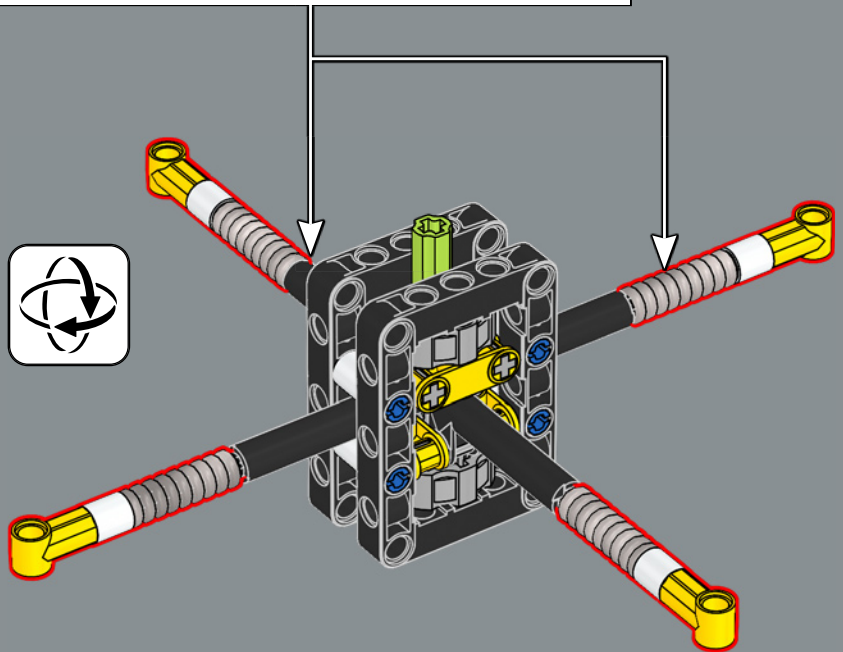
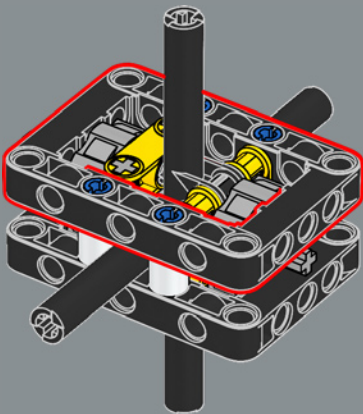
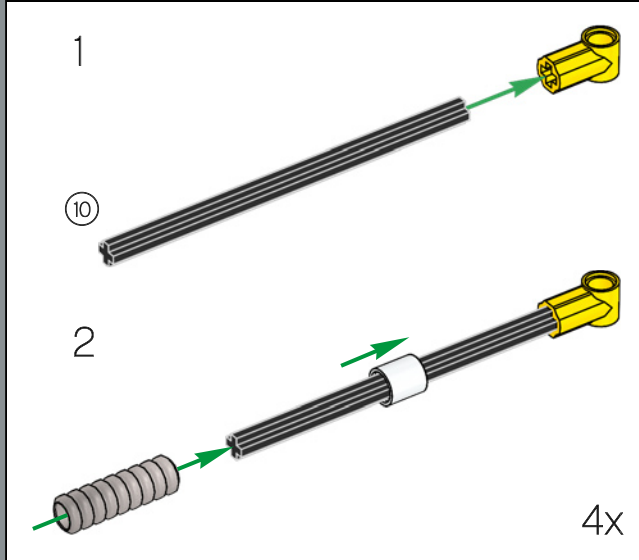

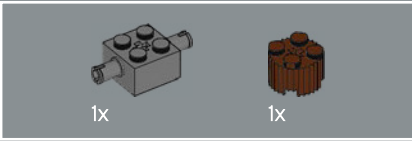
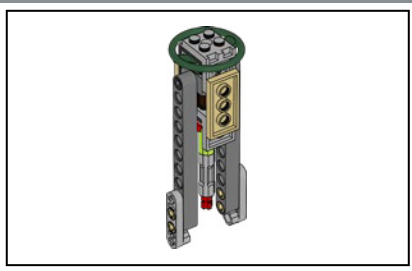

161

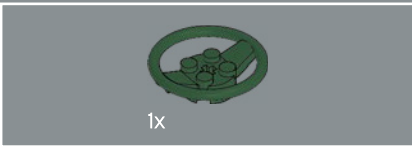
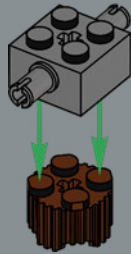

162

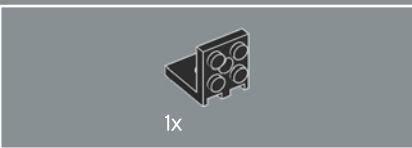
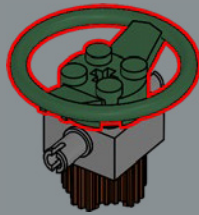

163

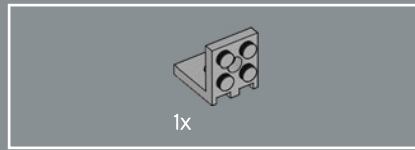
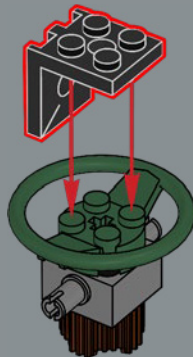

164

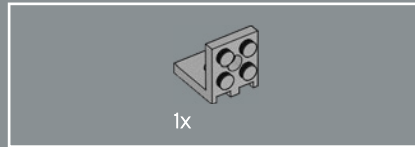
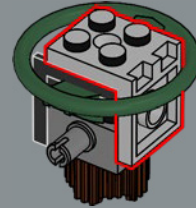

165

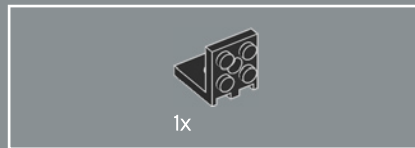
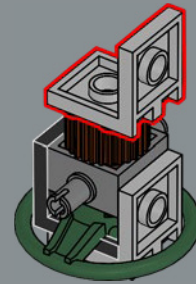

166

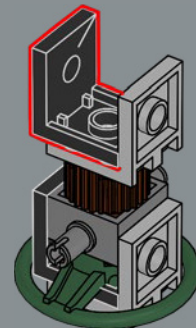



167

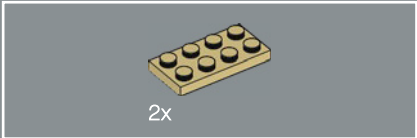
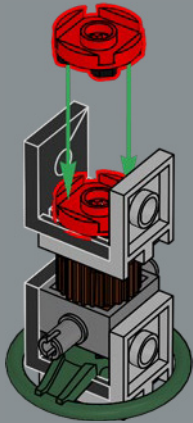

168

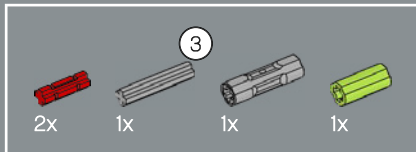
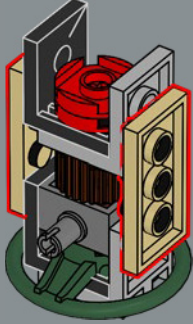

169

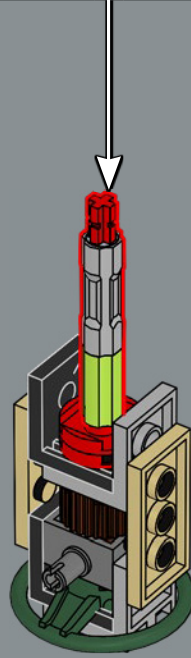
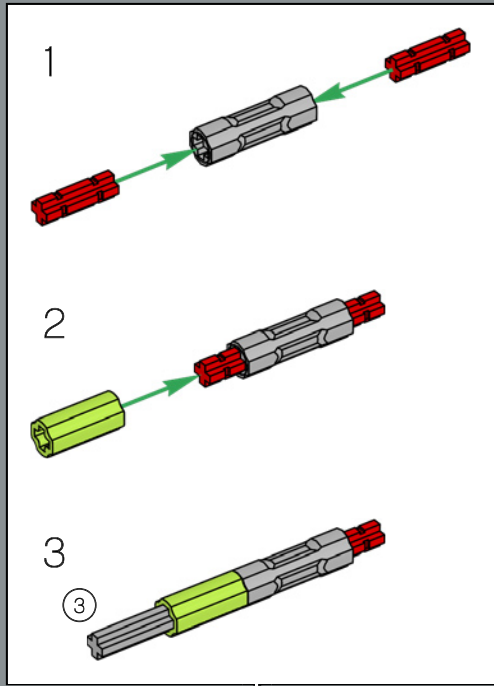

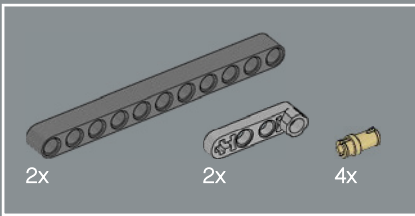

170

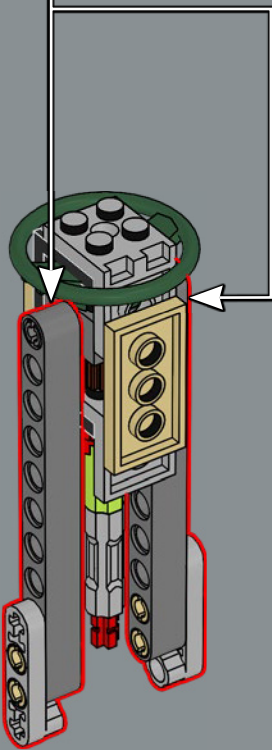
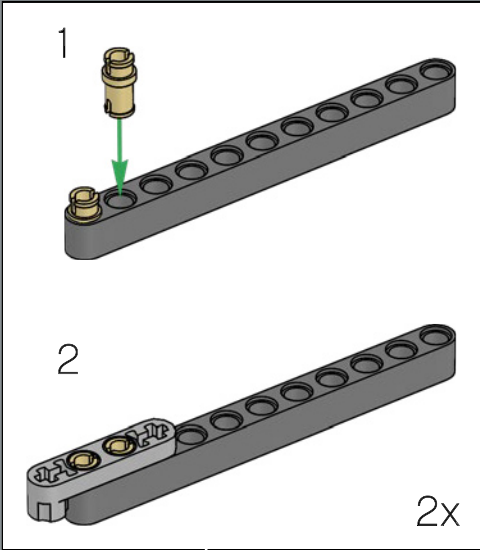

171

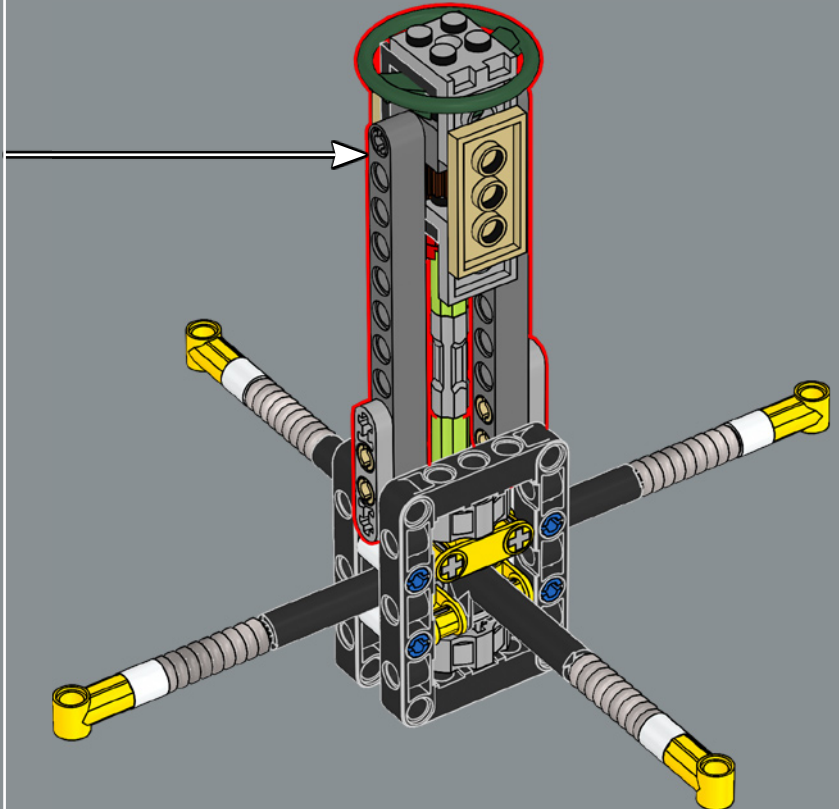

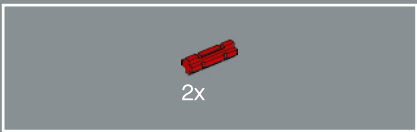

172

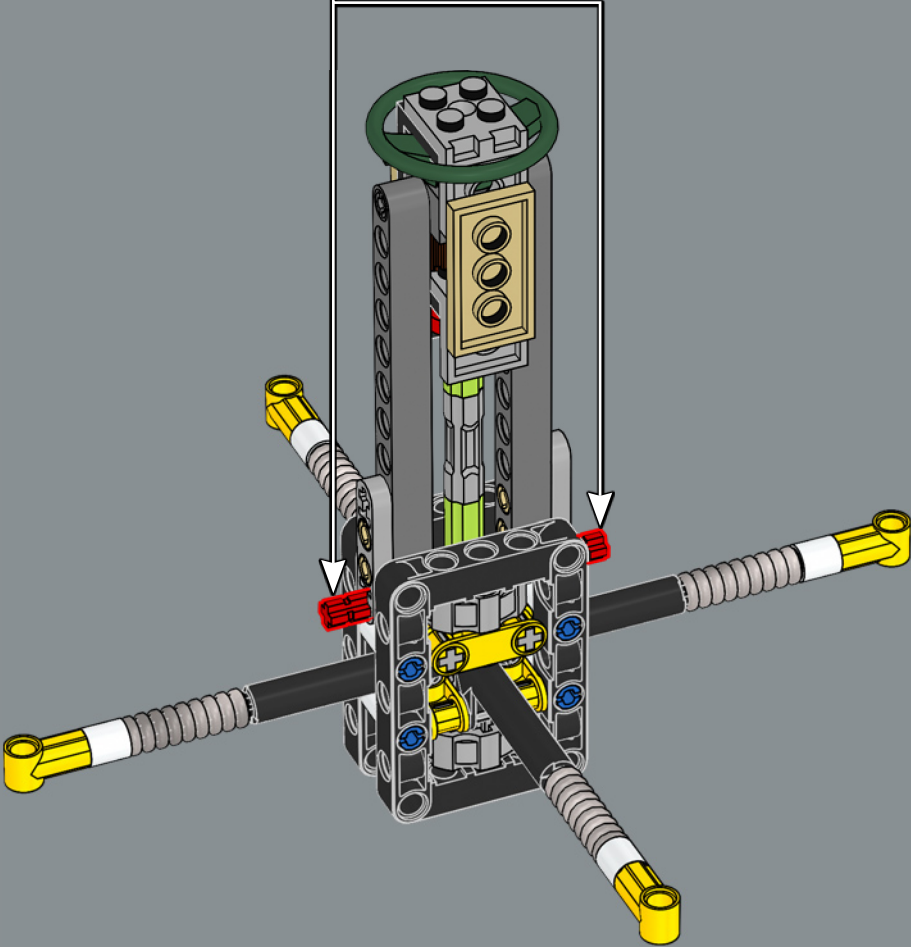
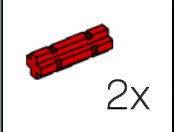



173

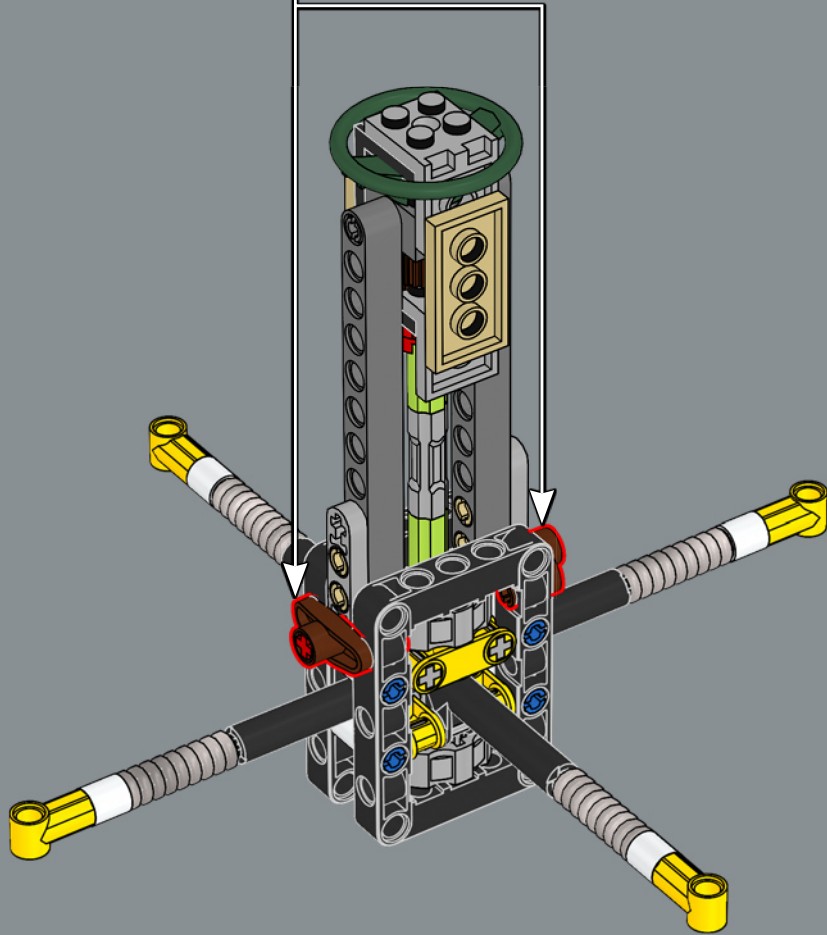
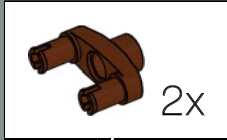

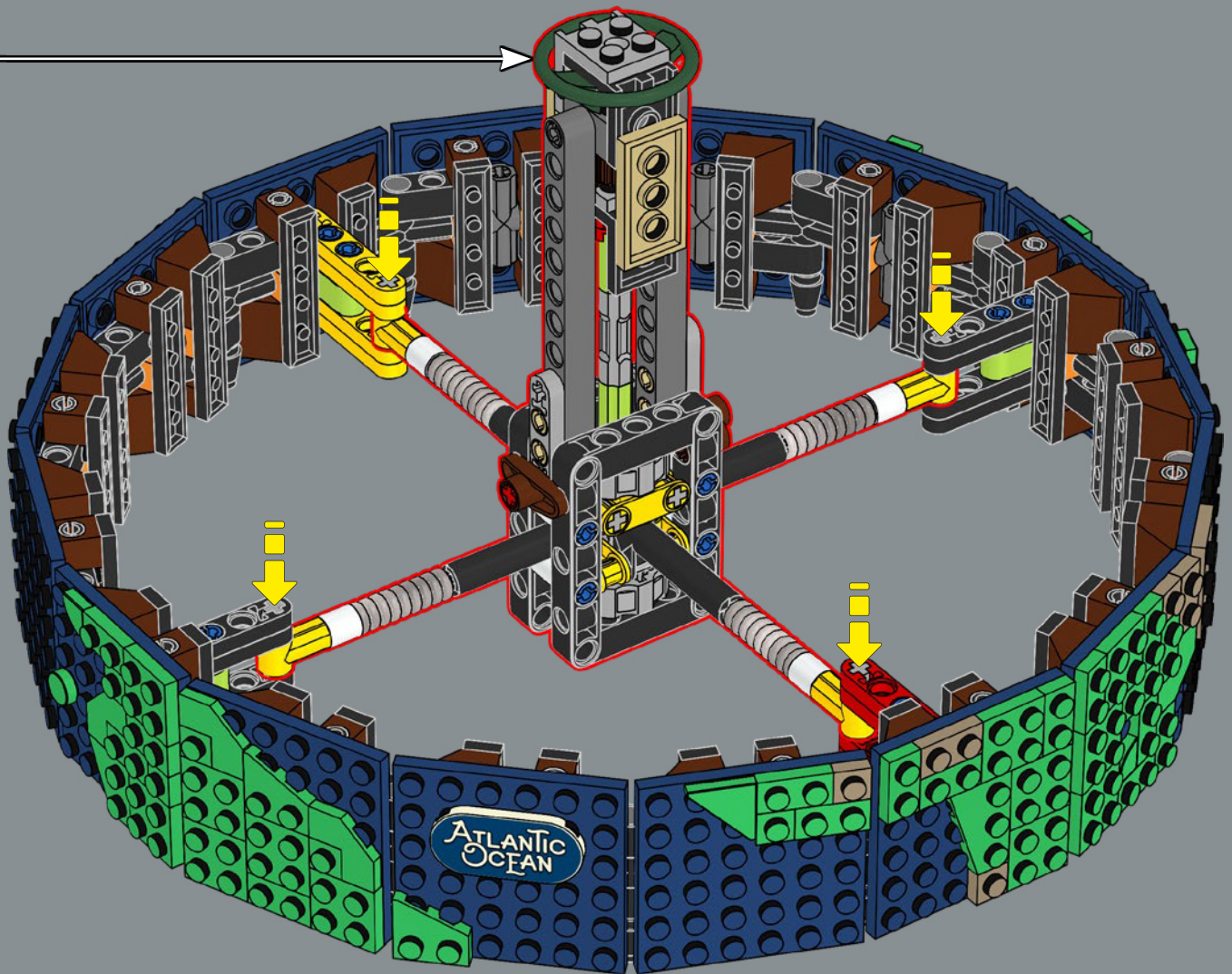



175

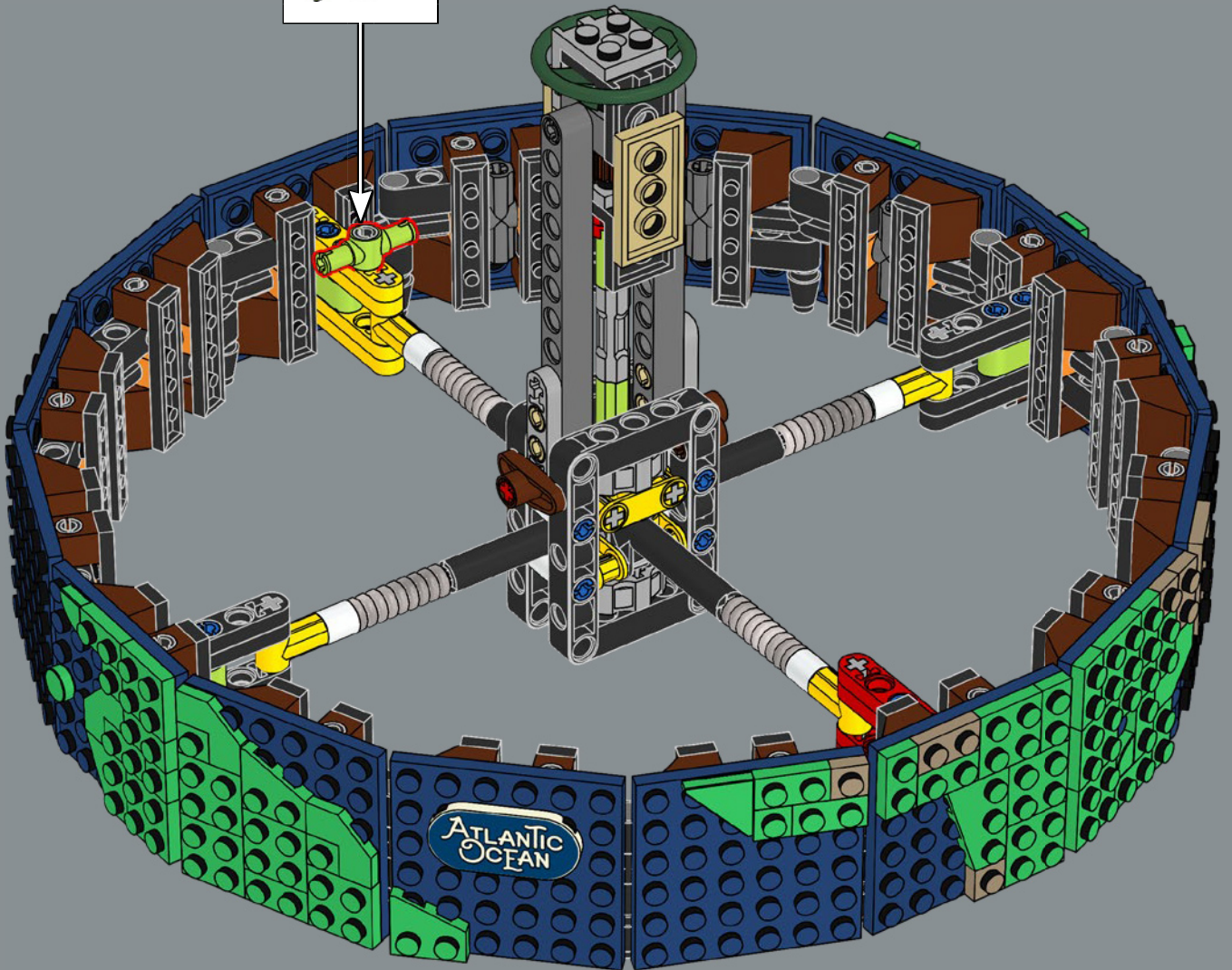
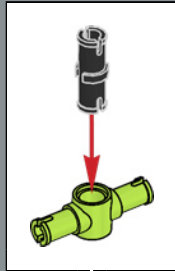



176

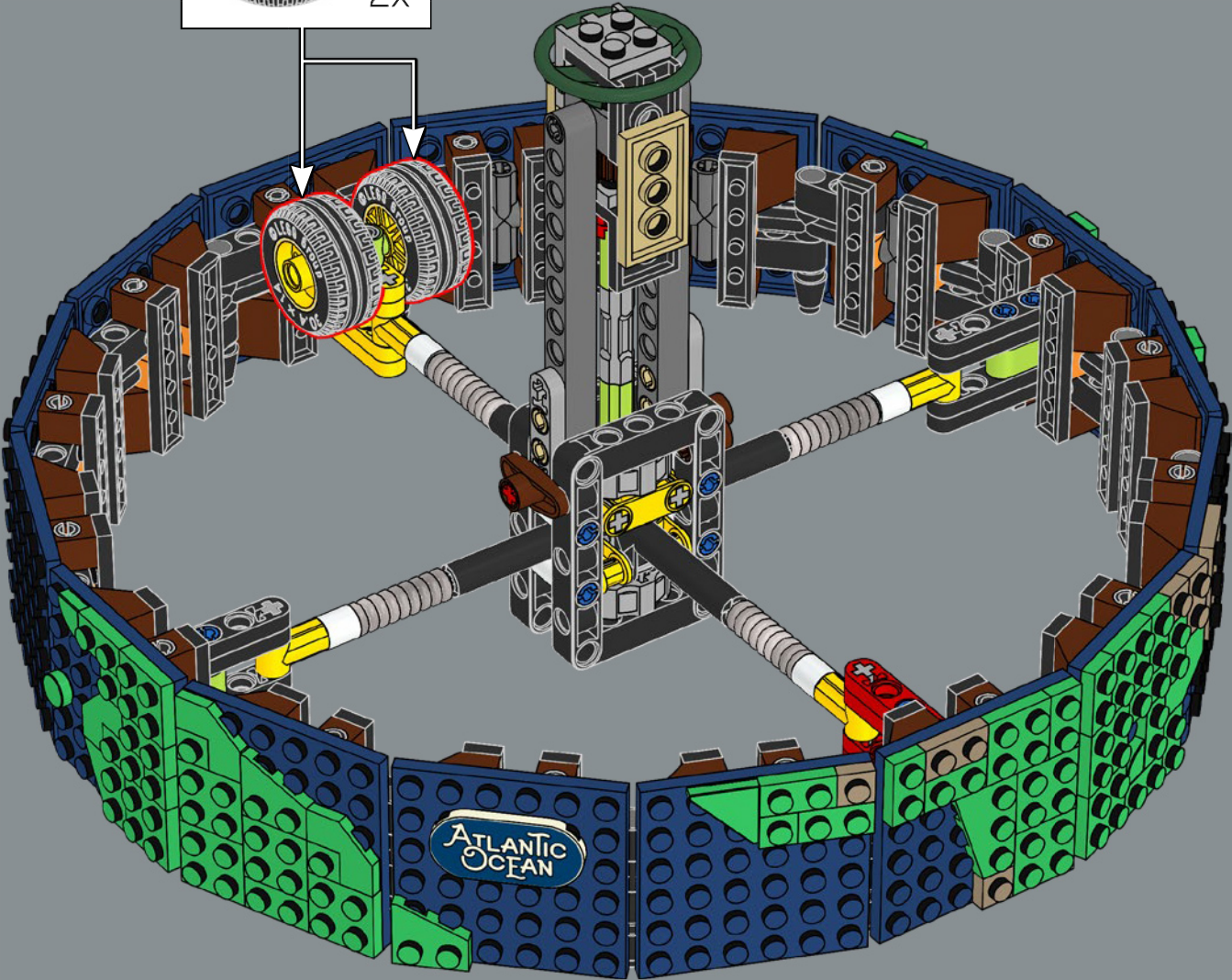
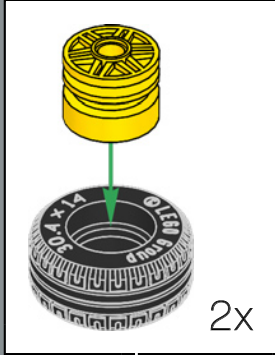

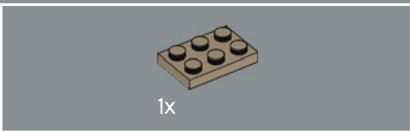
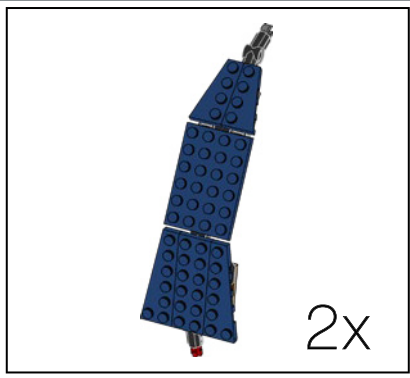
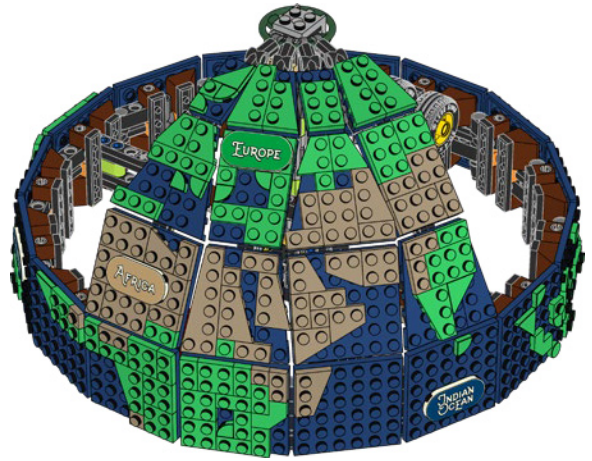

177

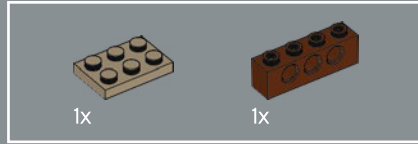

178

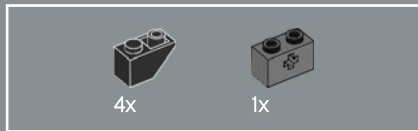
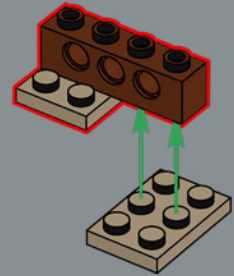

179

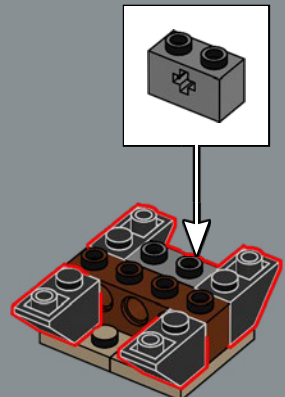

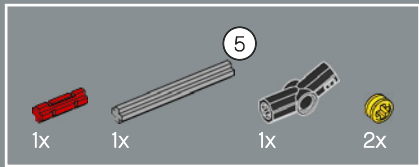

180

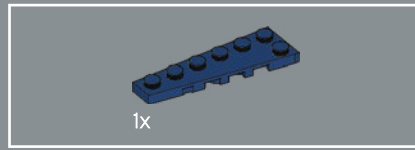
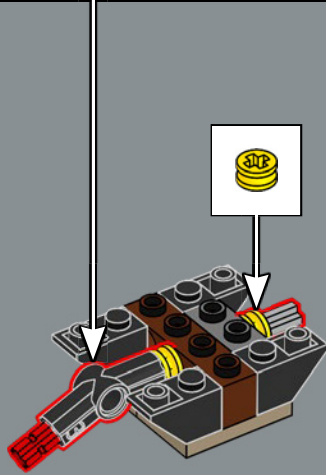
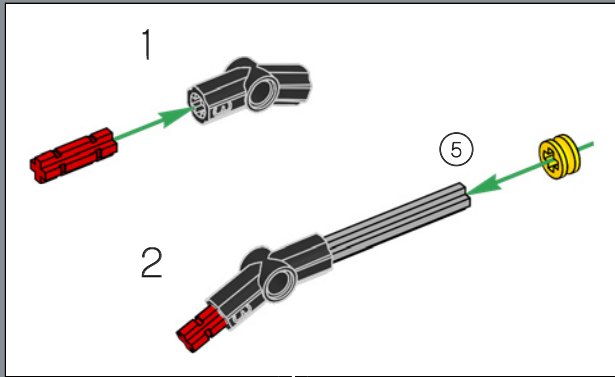

181

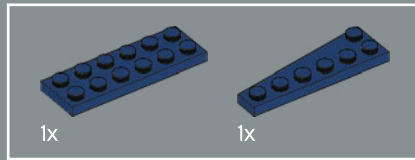
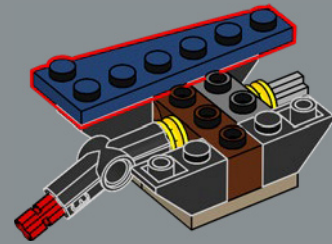

182

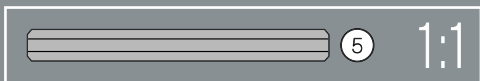
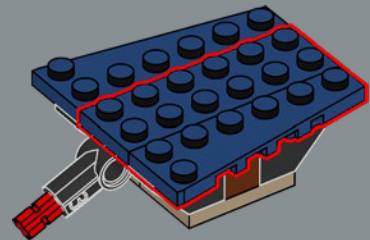

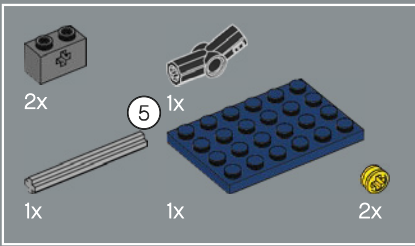

183

1

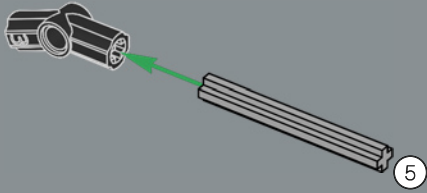

2

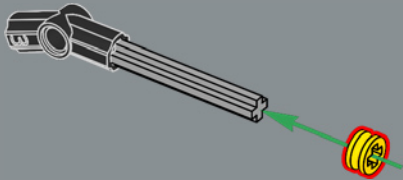

3

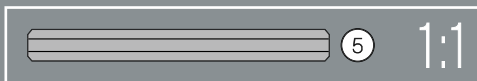
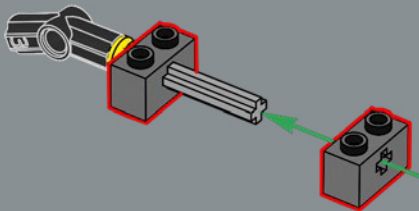

4

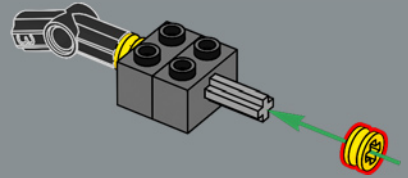

5

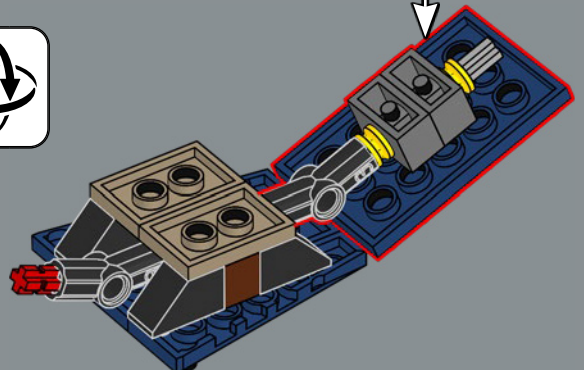
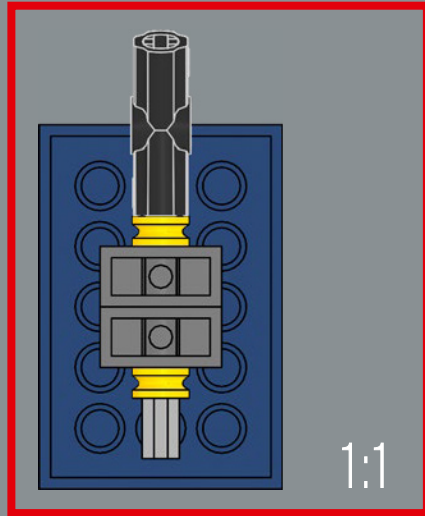
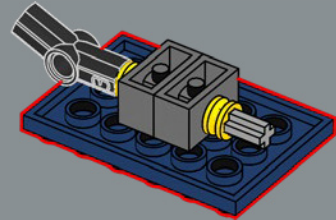

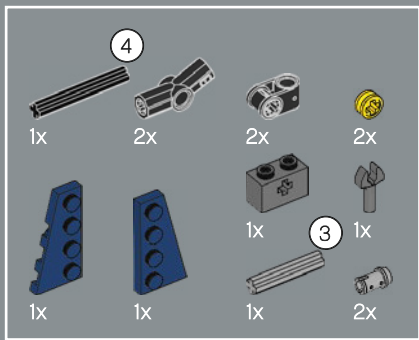

184

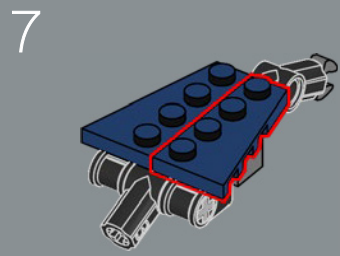
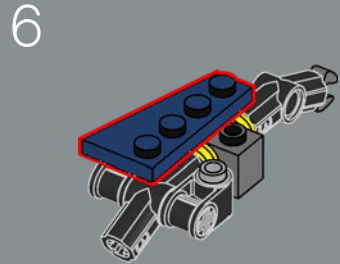
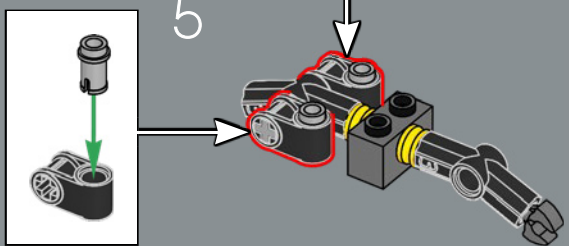
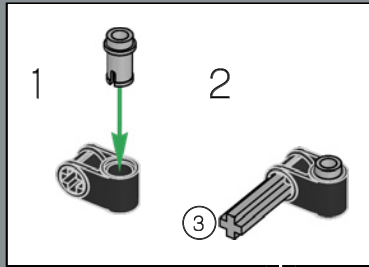
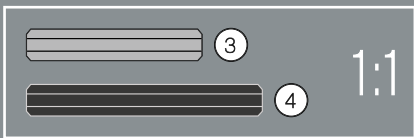
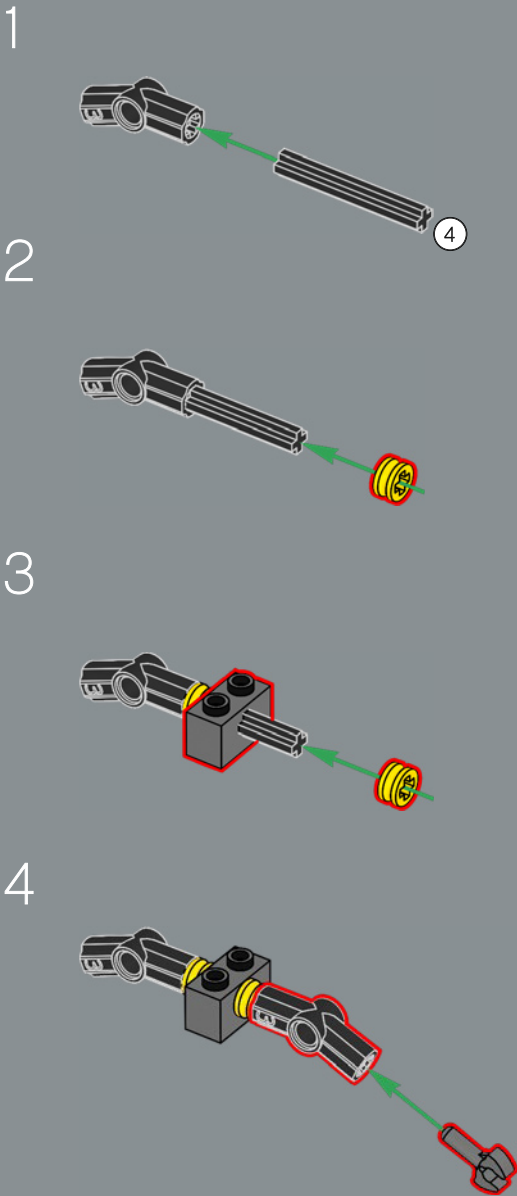

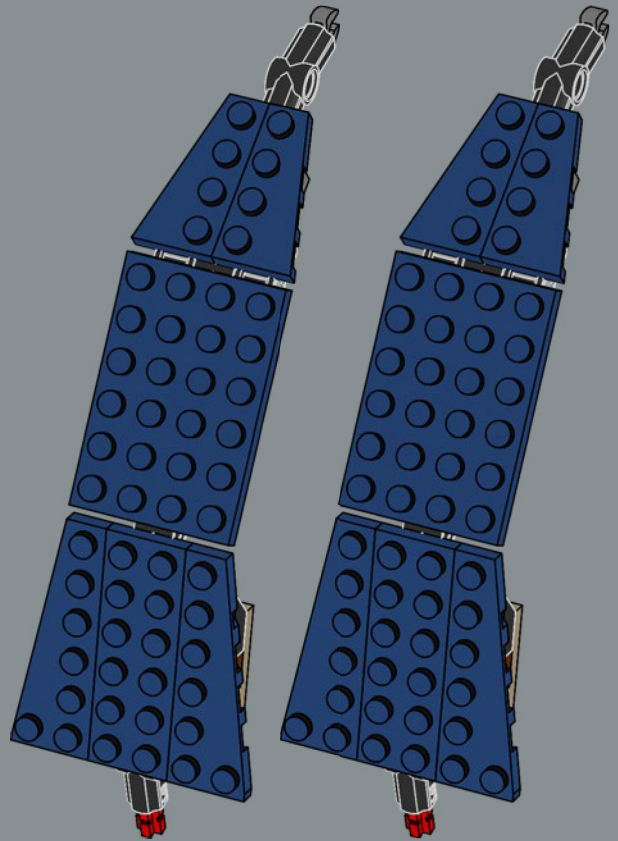
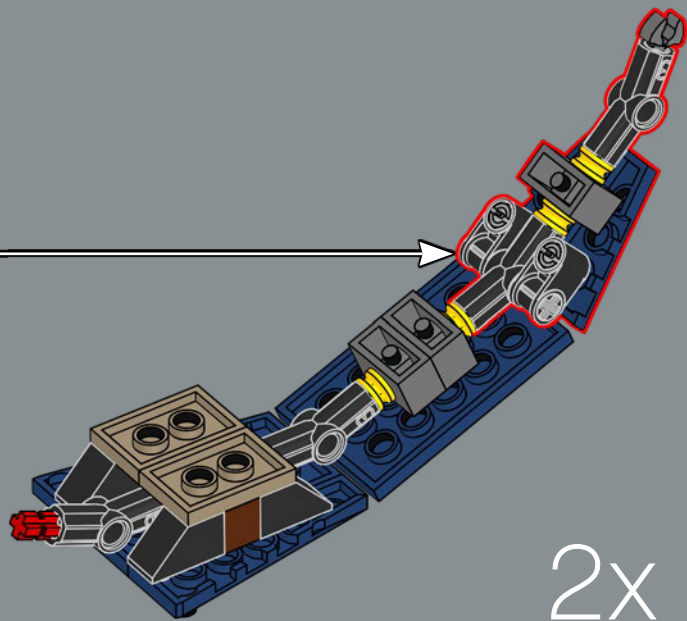

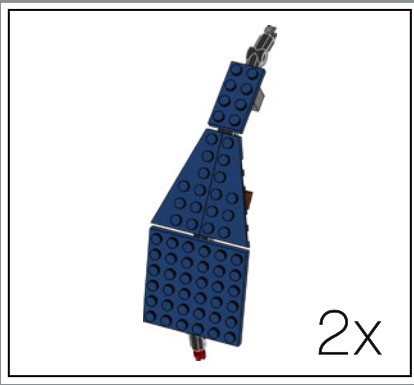

2x

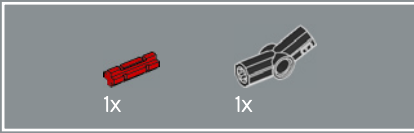

1x

1x

185

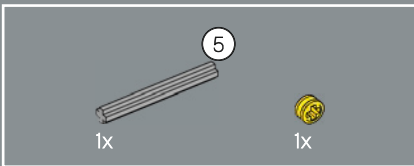
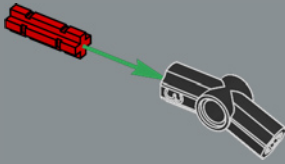

1x

1x

186

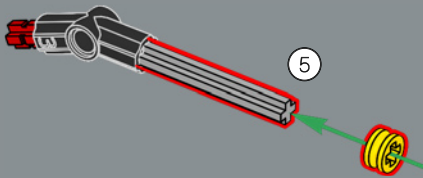

5

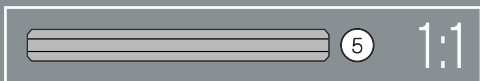

5

1:1

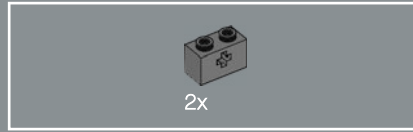

2x

187

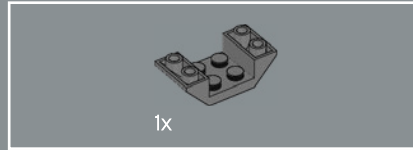
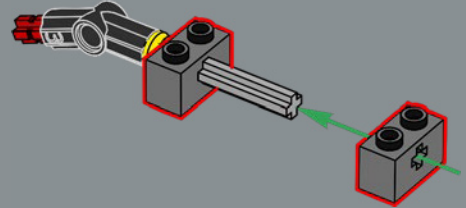

1x

188

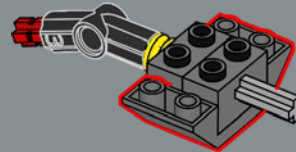

1x

189

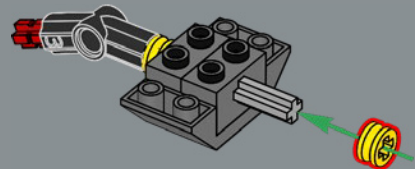

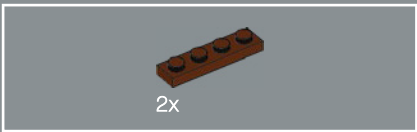

2x

190

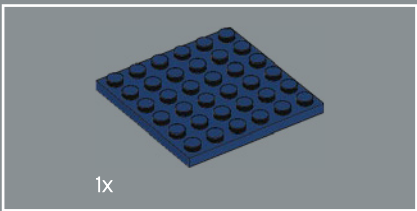
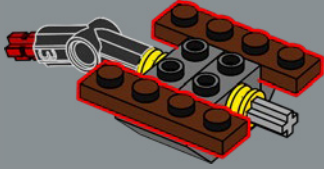

1x

191

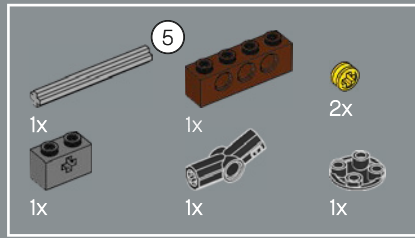
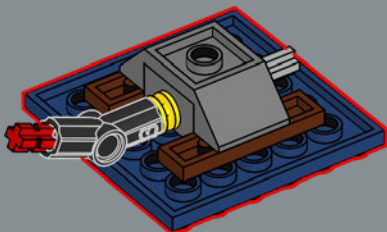

5

1x

1x

2x

1x

1x

1x

192

1

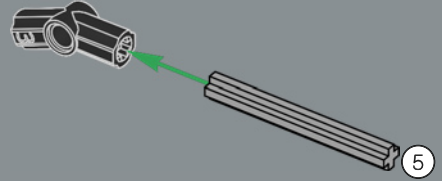

2

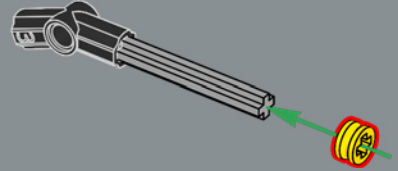

3

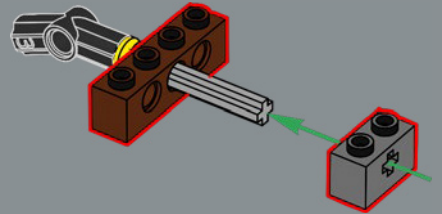

4

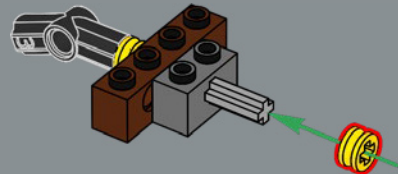

5

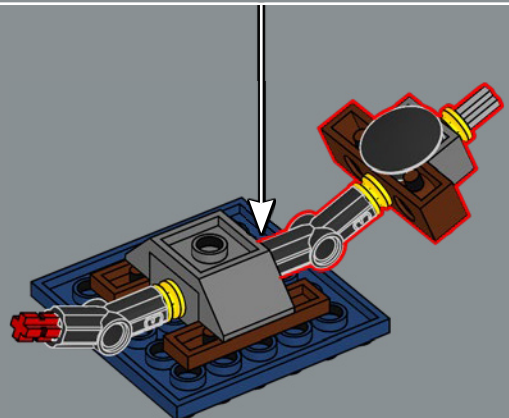
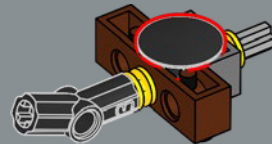

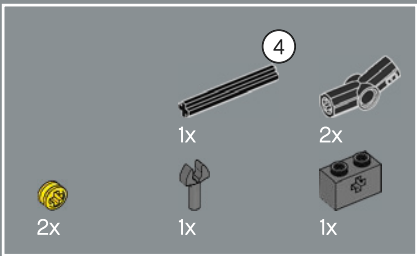

193

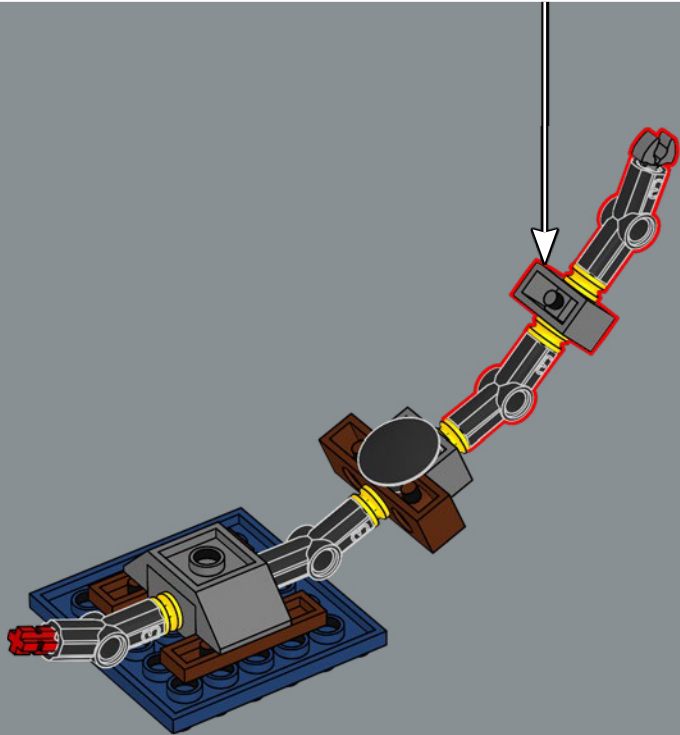
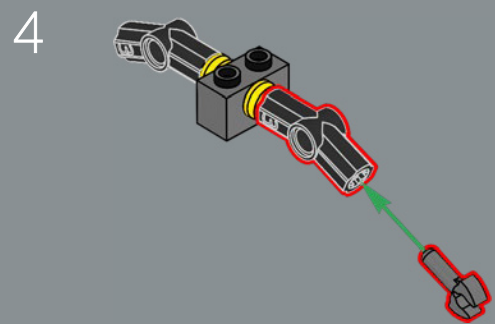
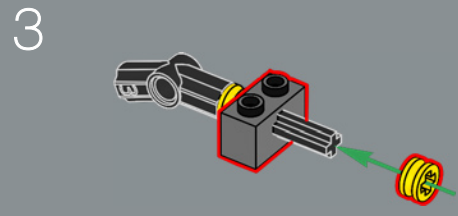
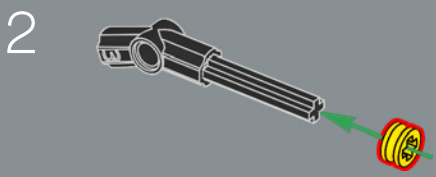
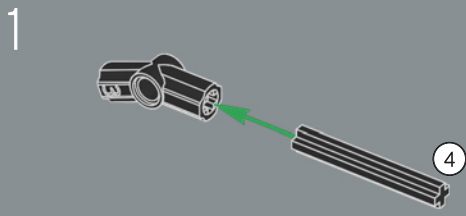

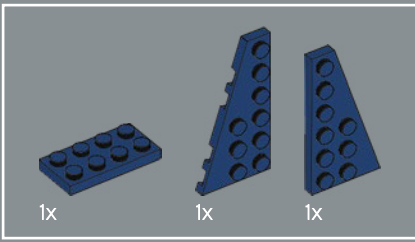

194

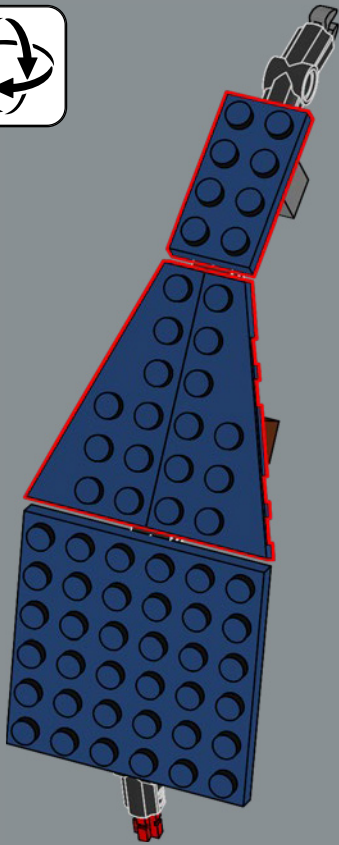

2x

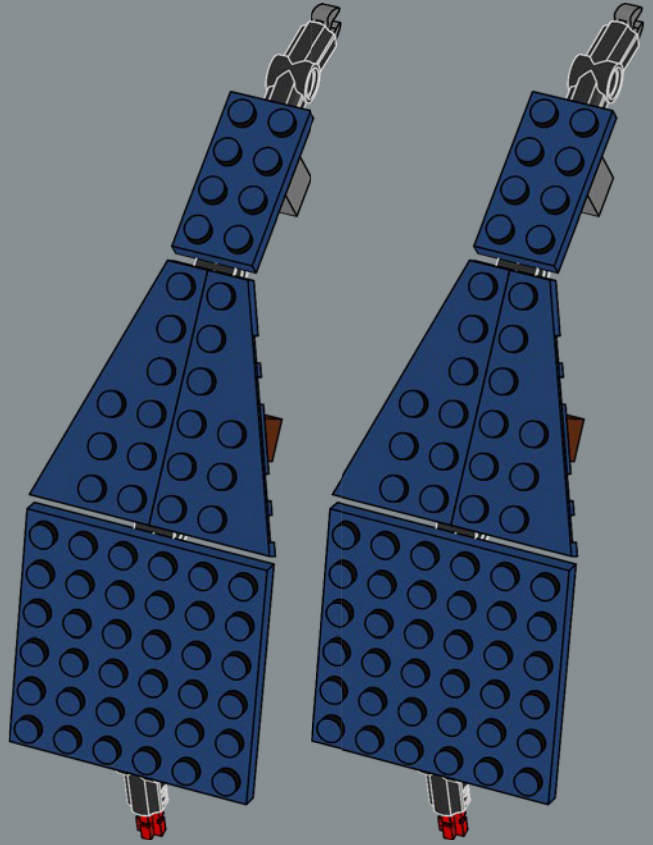

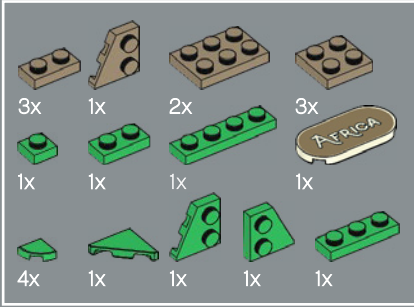
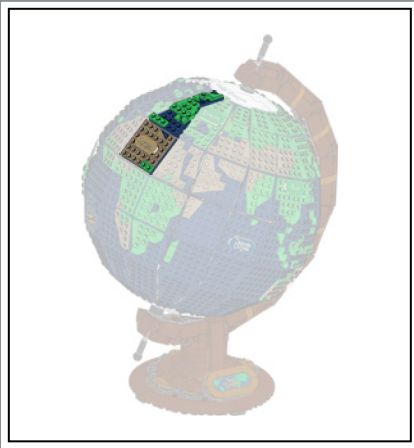

195

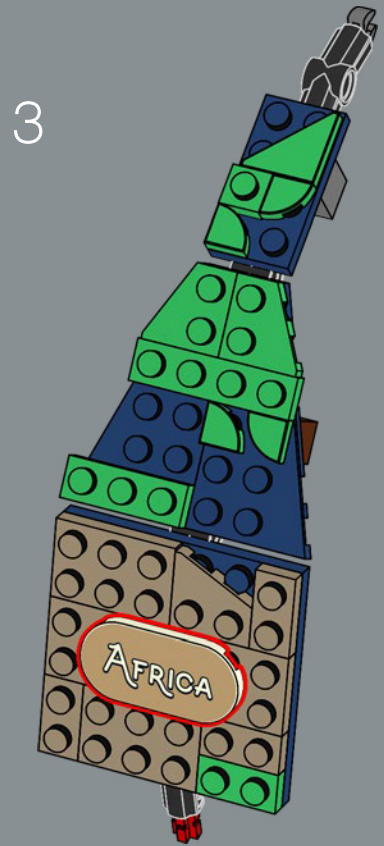
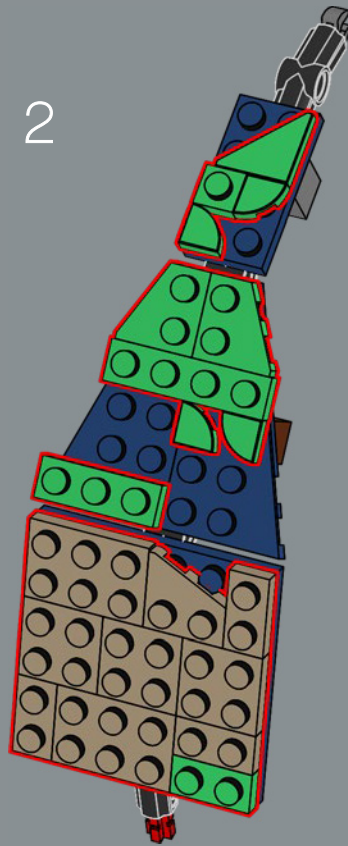
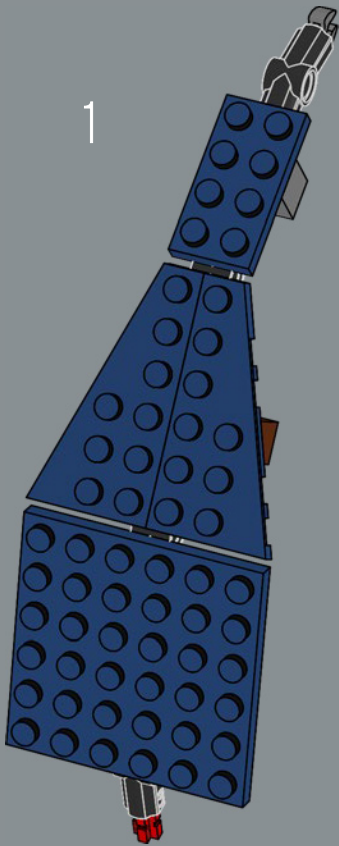

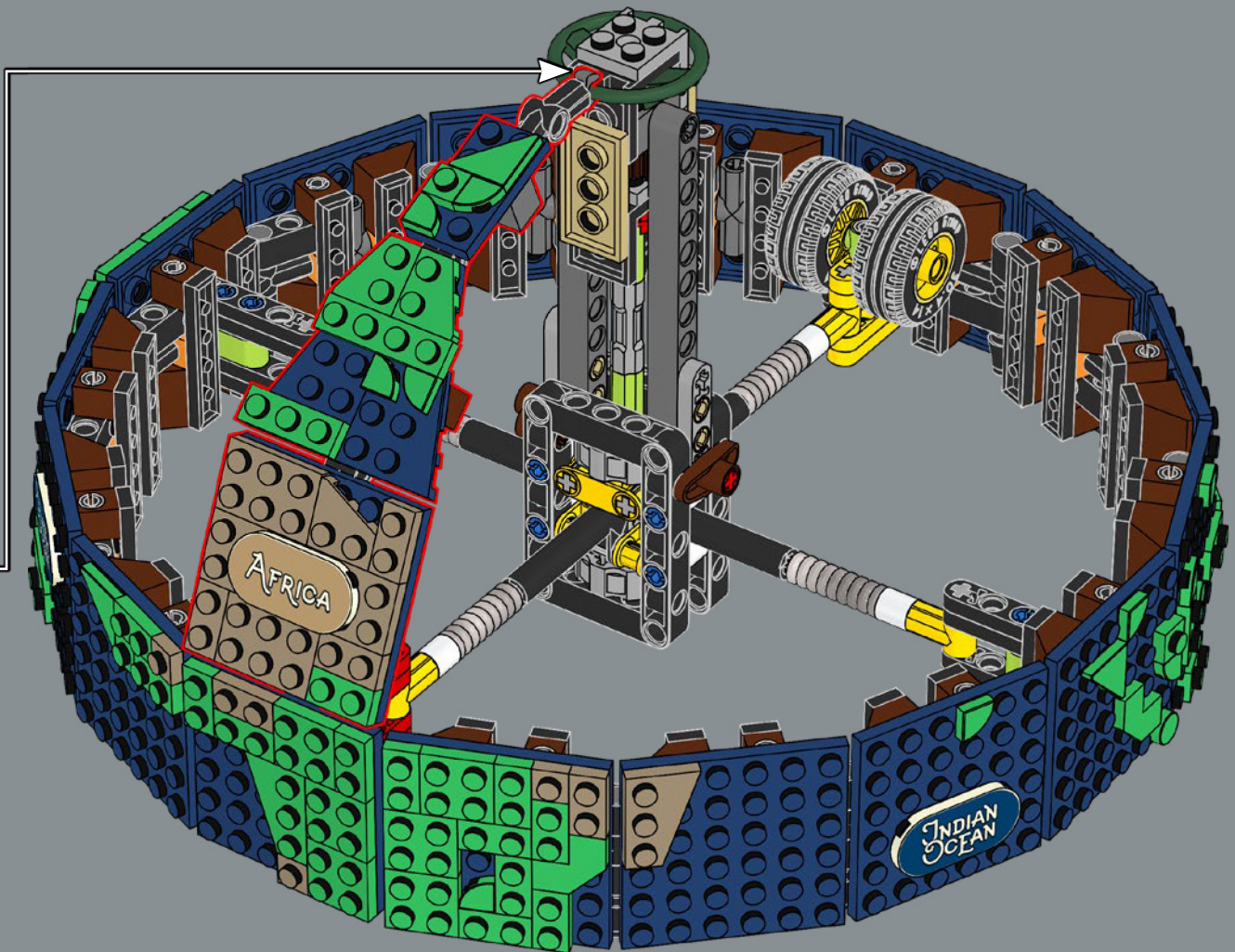

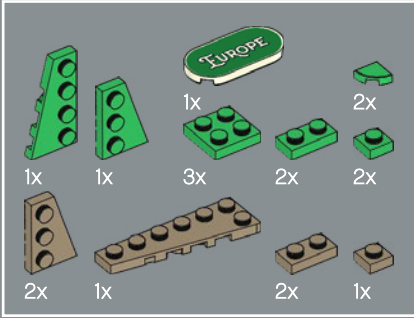

196

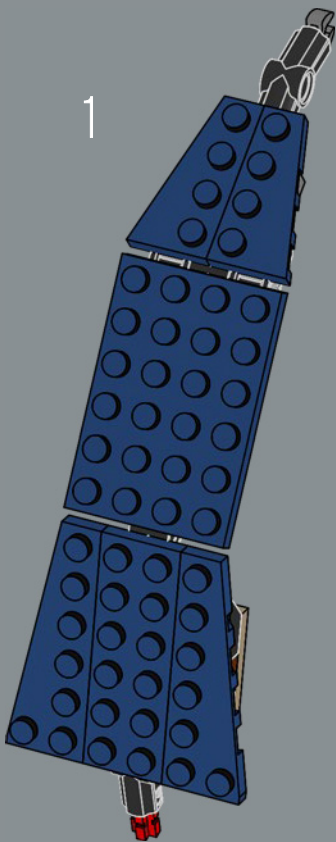

1

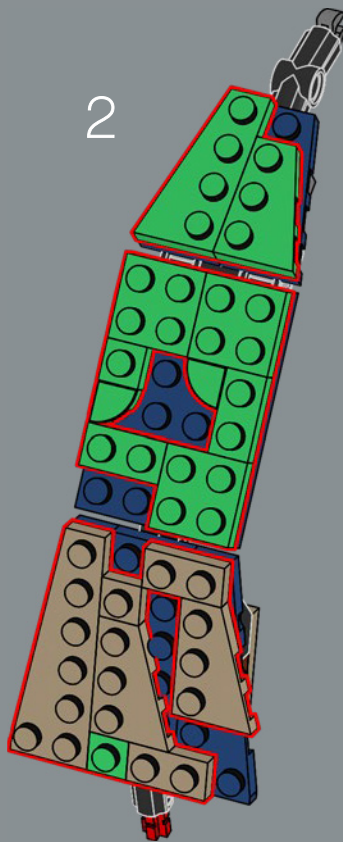

2

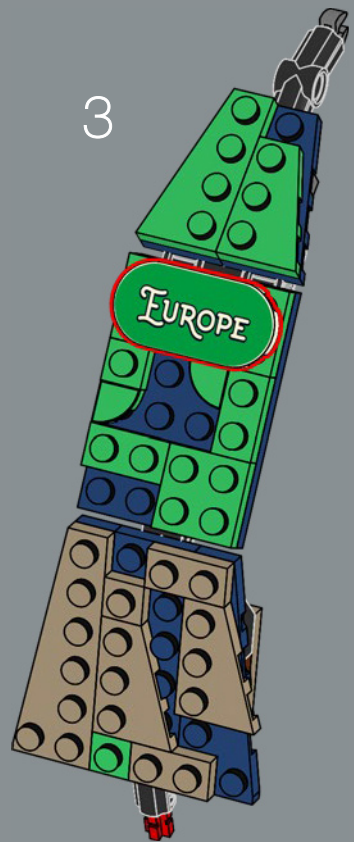

3

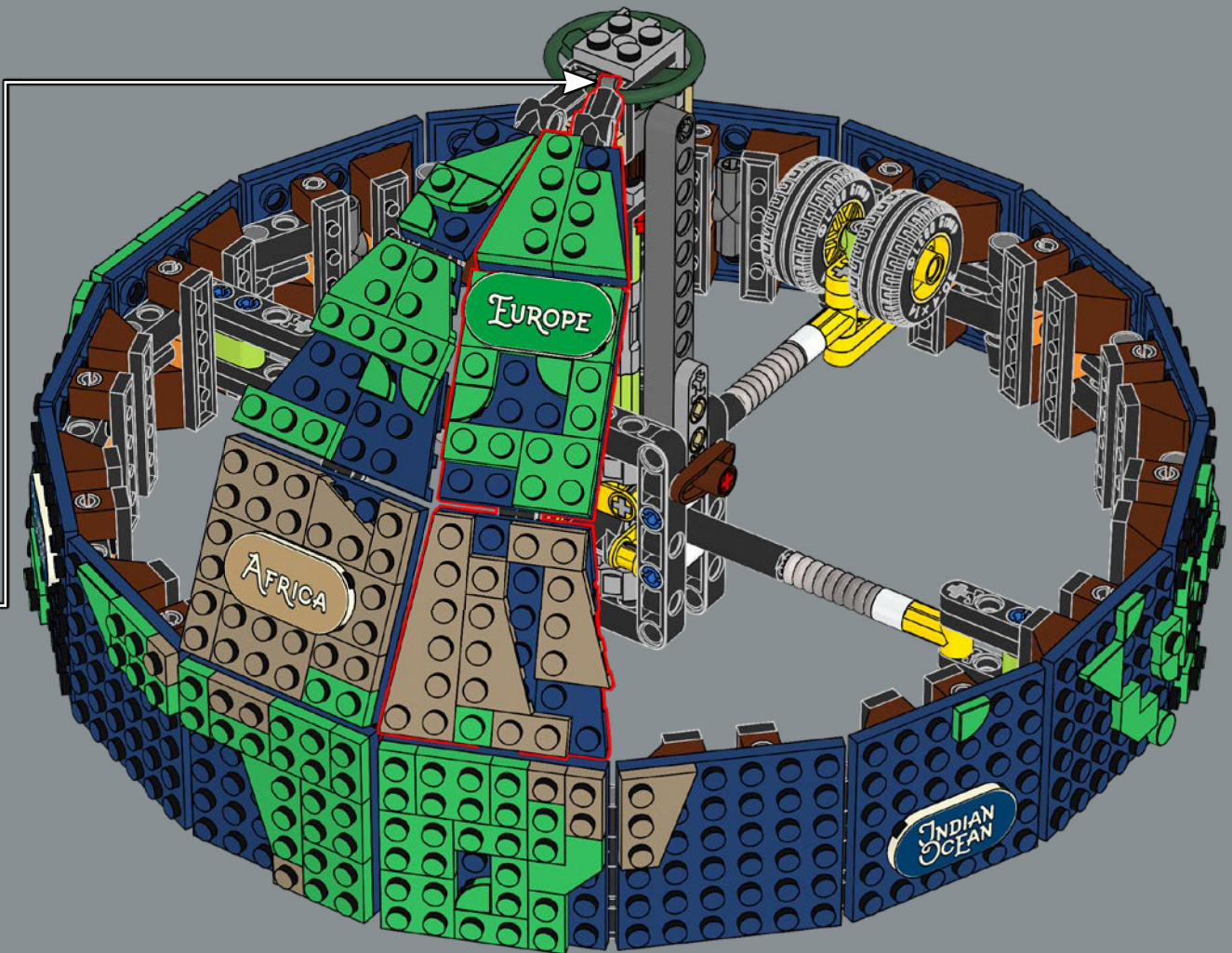

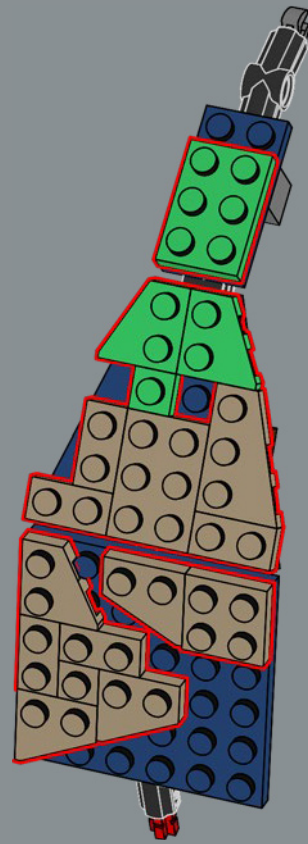
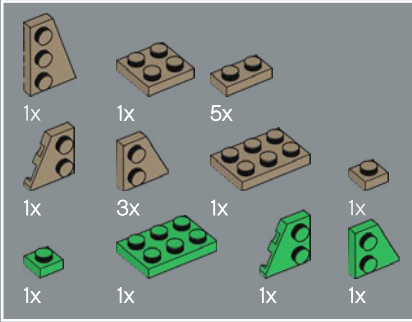
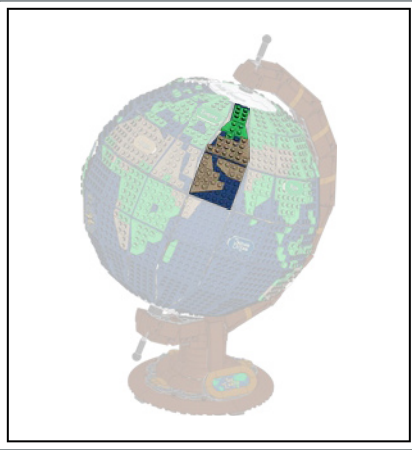

197

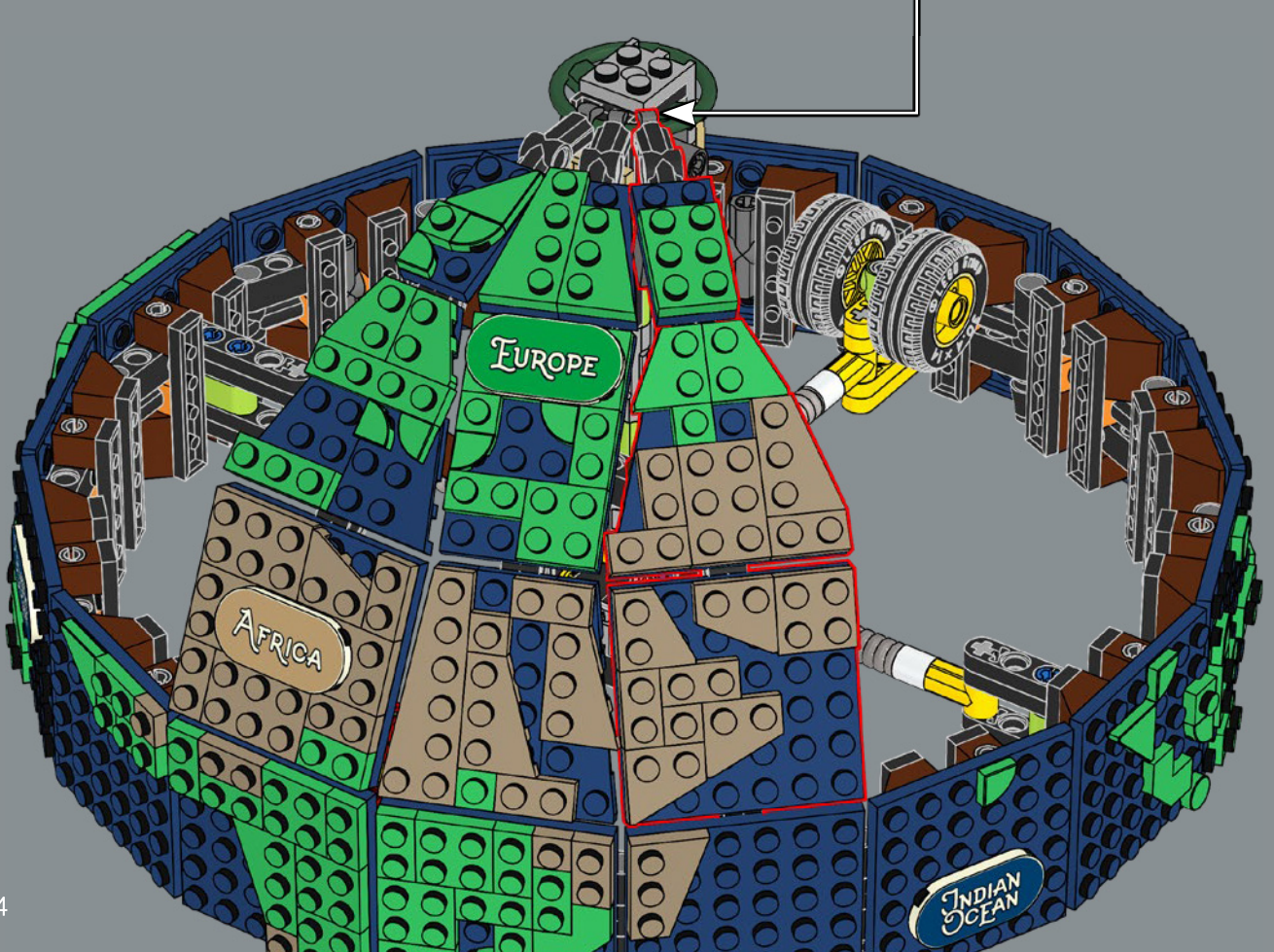

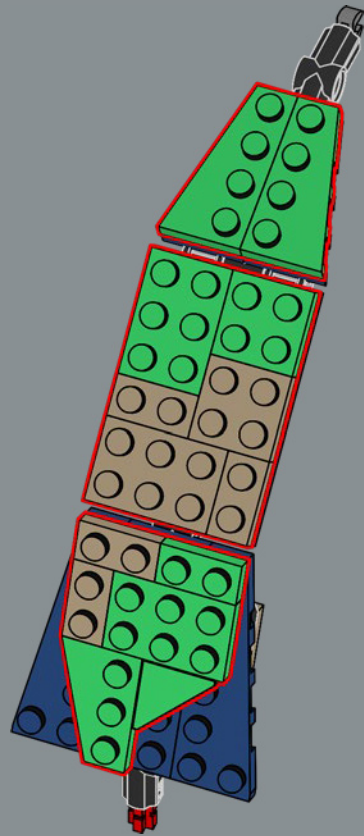
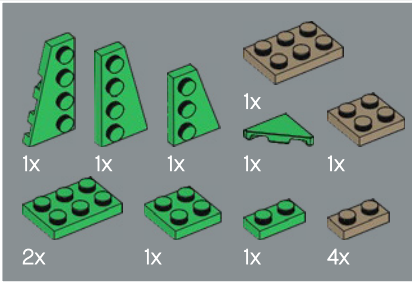
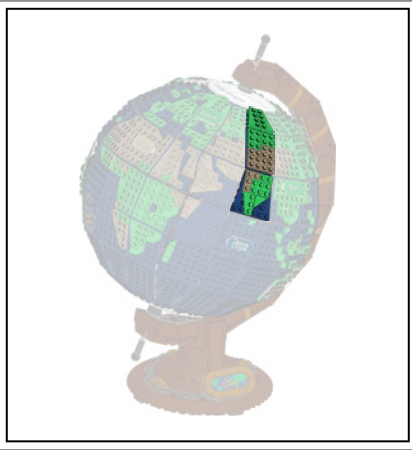

198



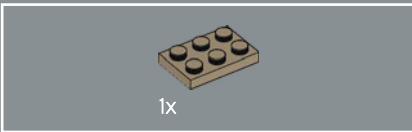
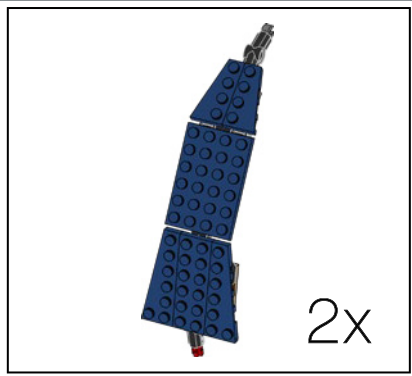
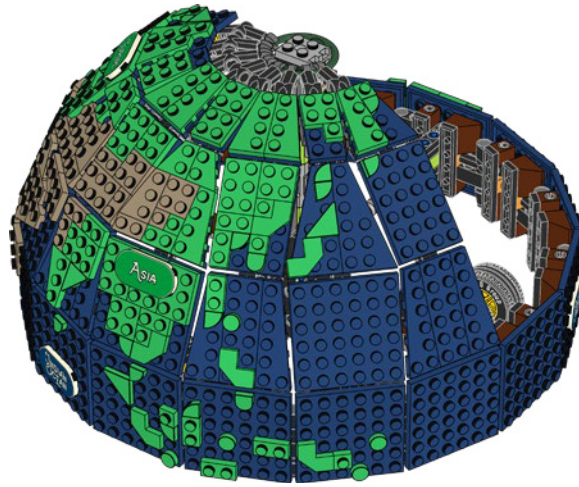

199

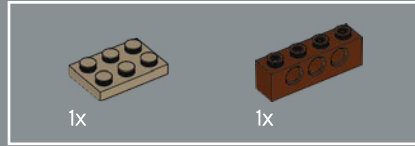

200

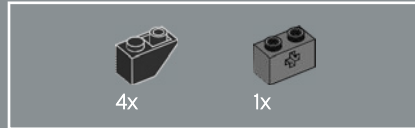
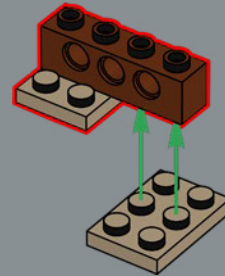

201

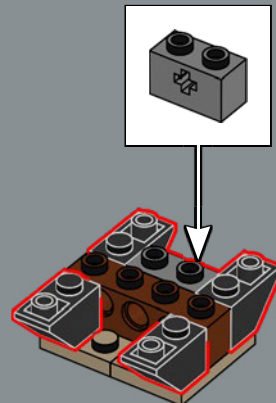

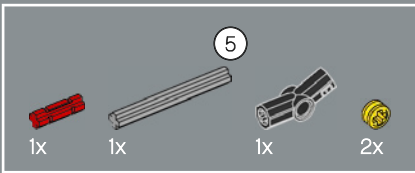

202

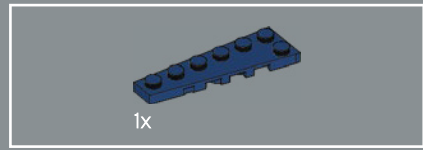
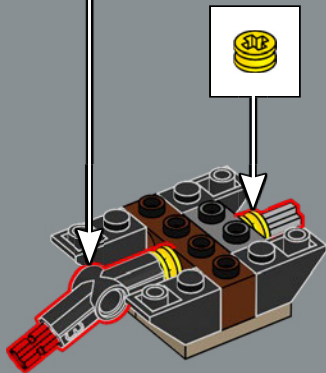
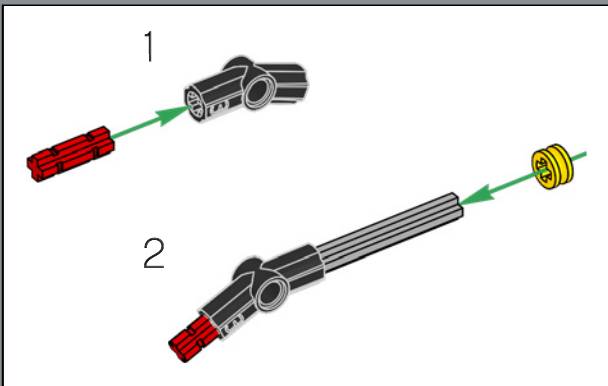

203

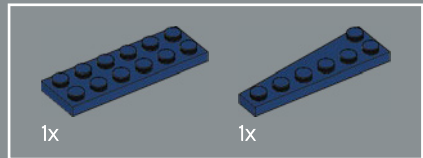
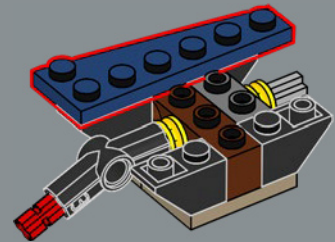

204

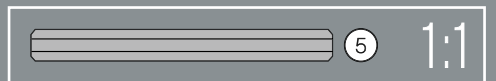
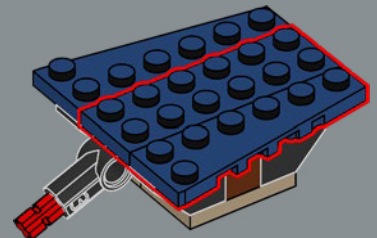

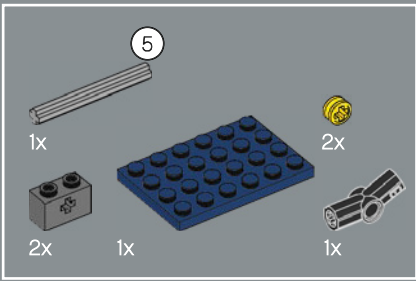

205

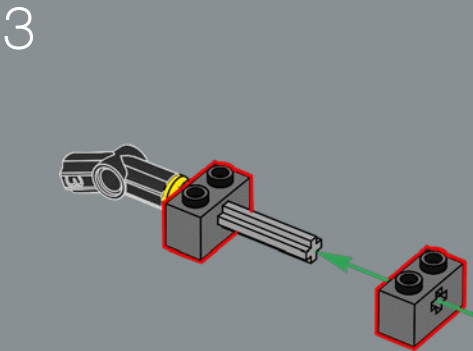
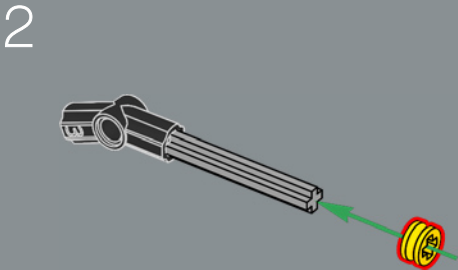
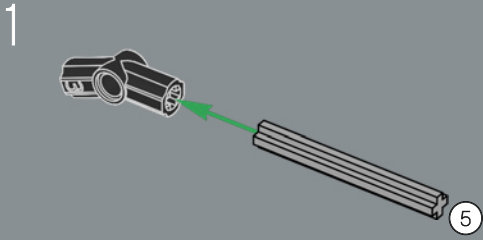

4

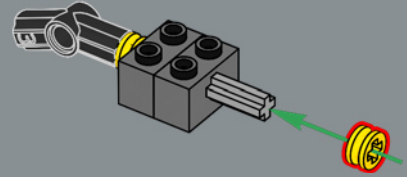

5

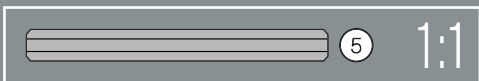
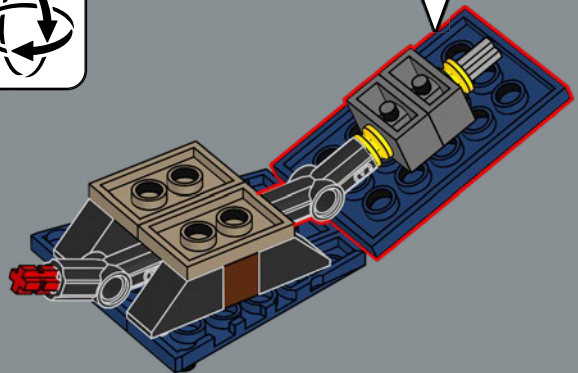
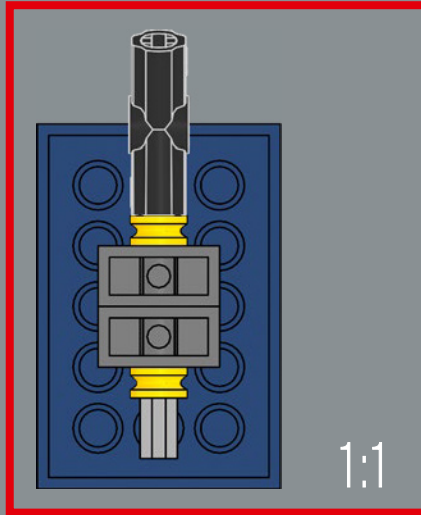
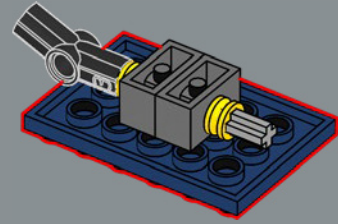

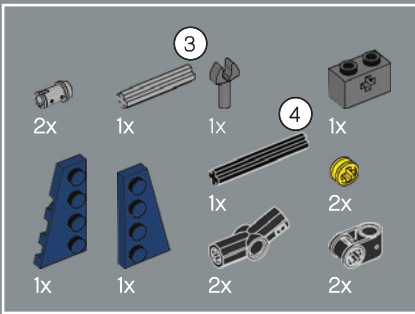

206

1

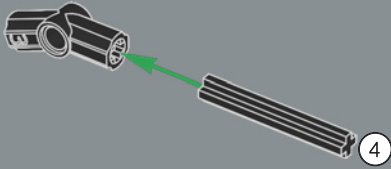

2

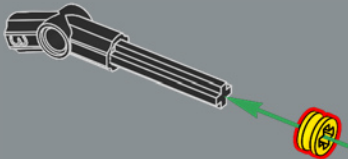

3

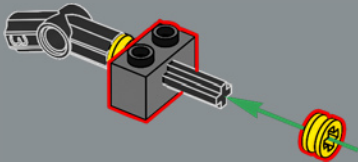

4

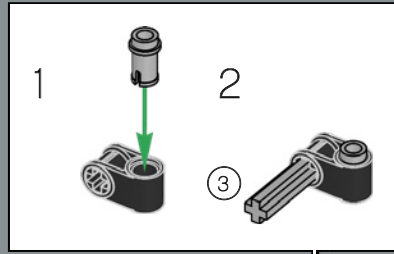
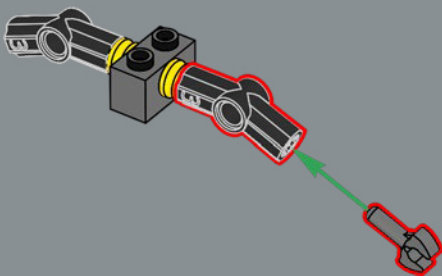

5

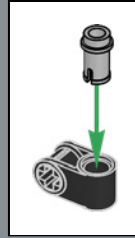

6

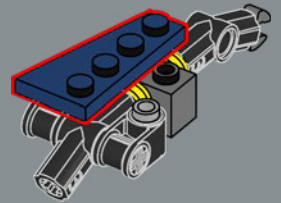

7

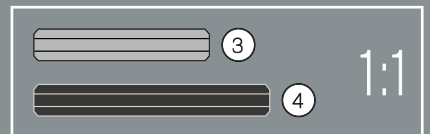
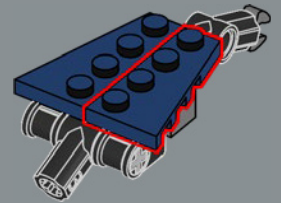

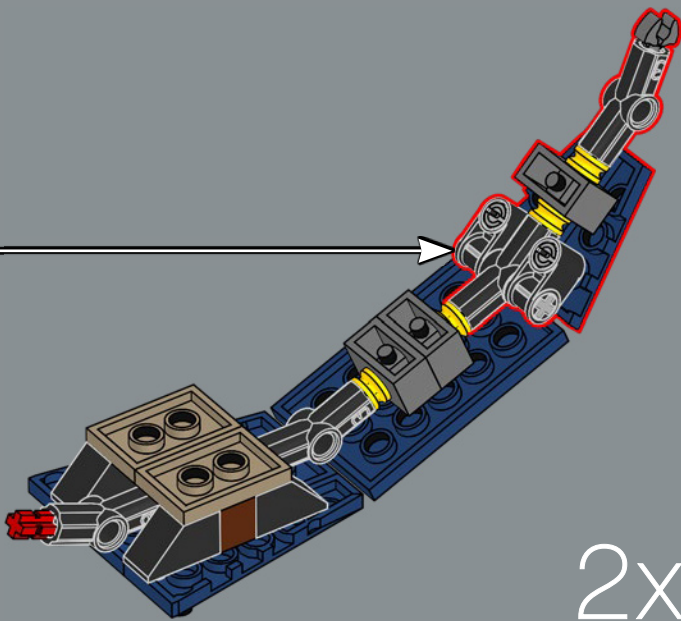

2x

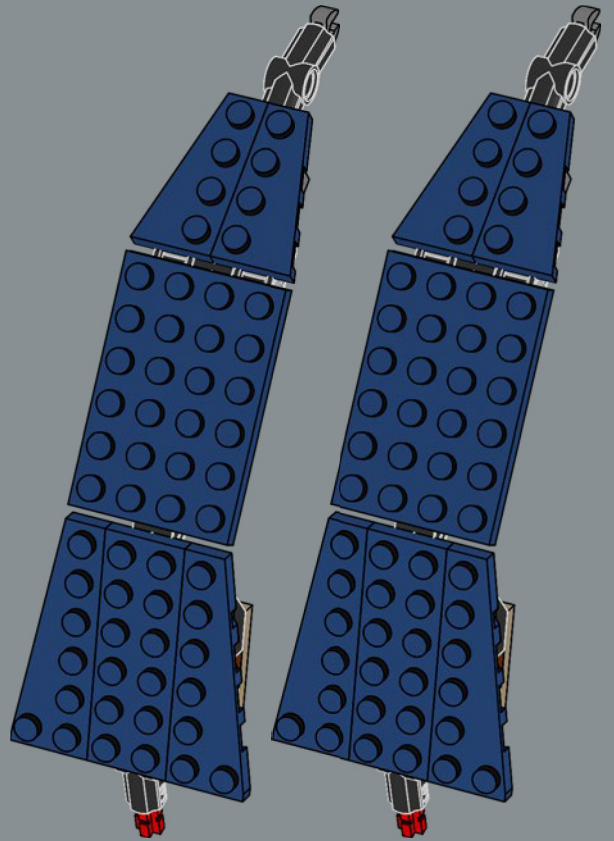

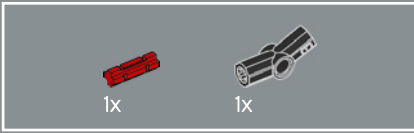
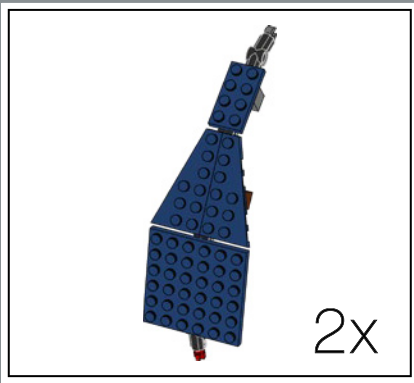

207

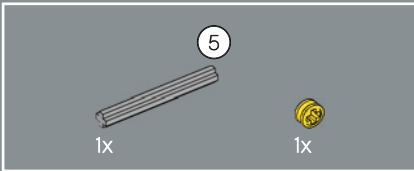
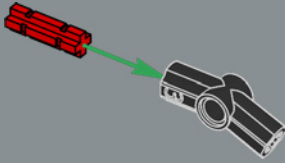

208

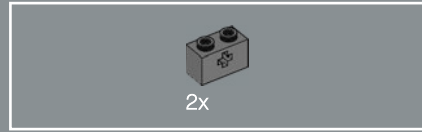
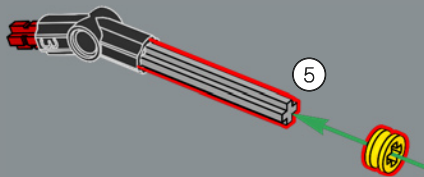

209

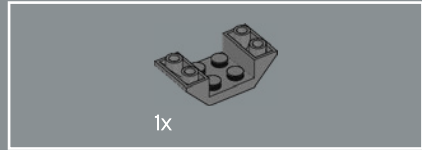
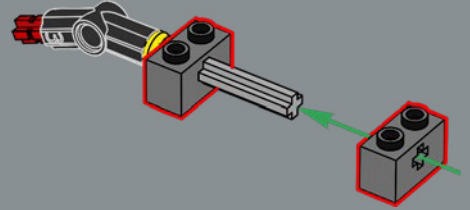

210

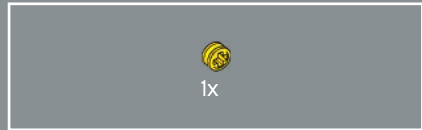
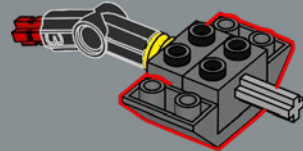

211

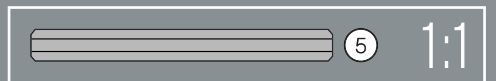
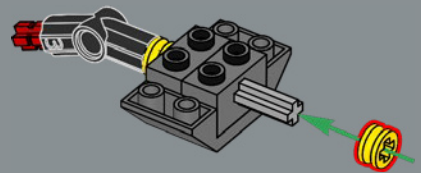

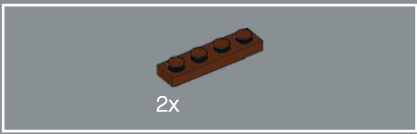

212

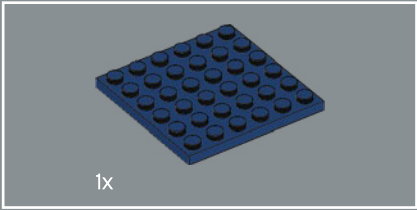
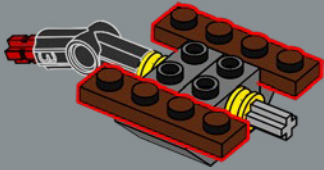

213

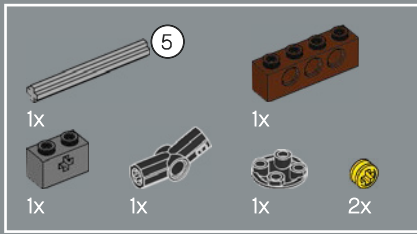
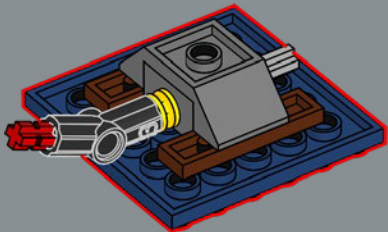

214

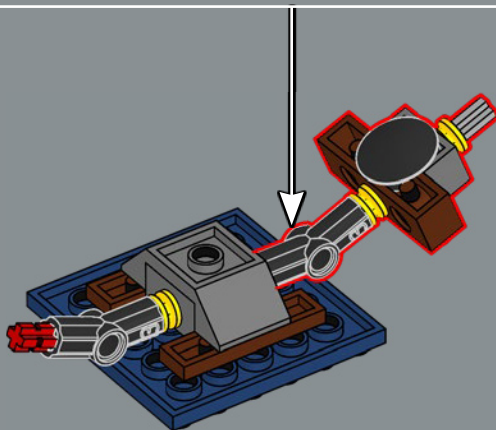
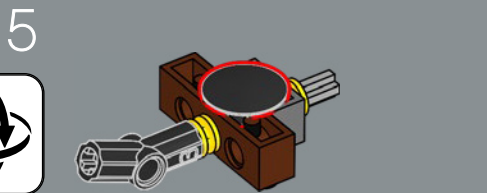
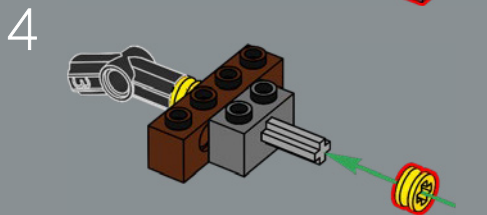
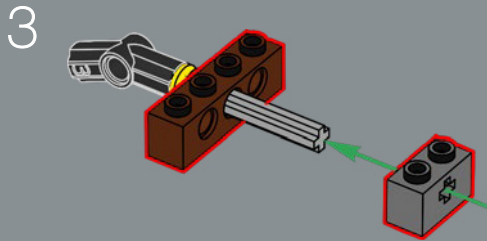
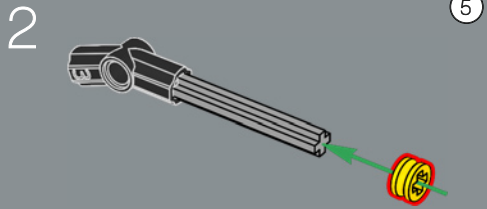
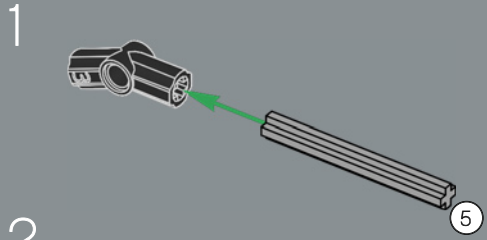

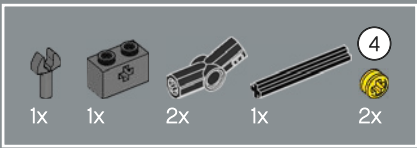

215

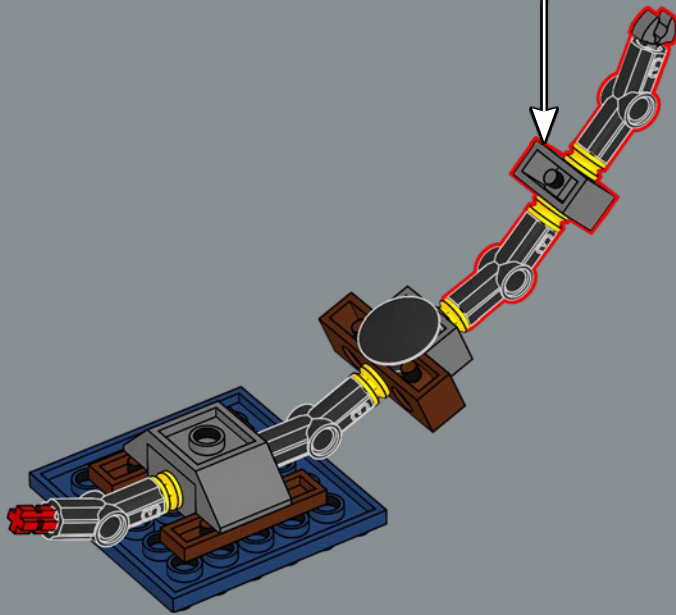
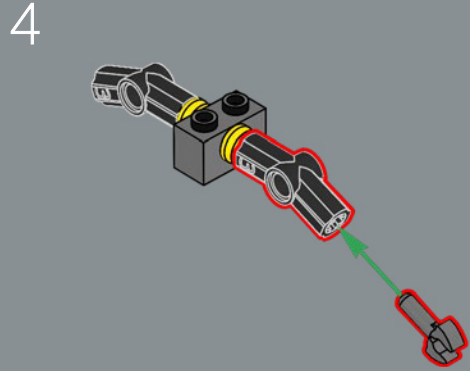
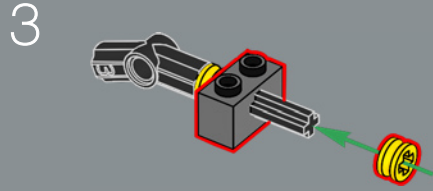
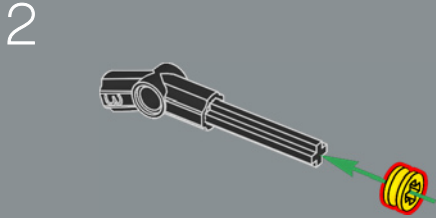
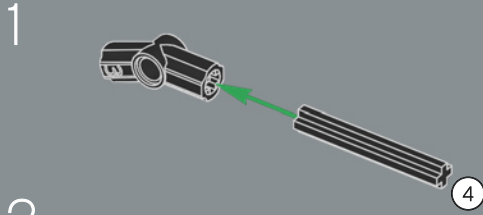

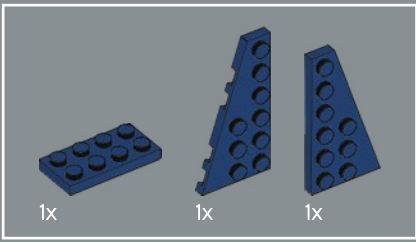

216

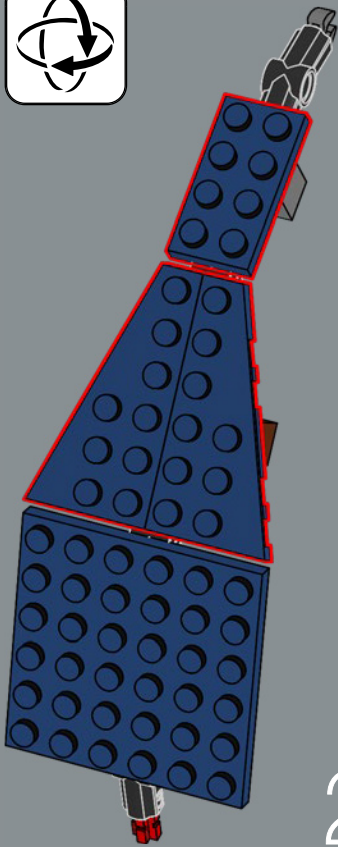

2x

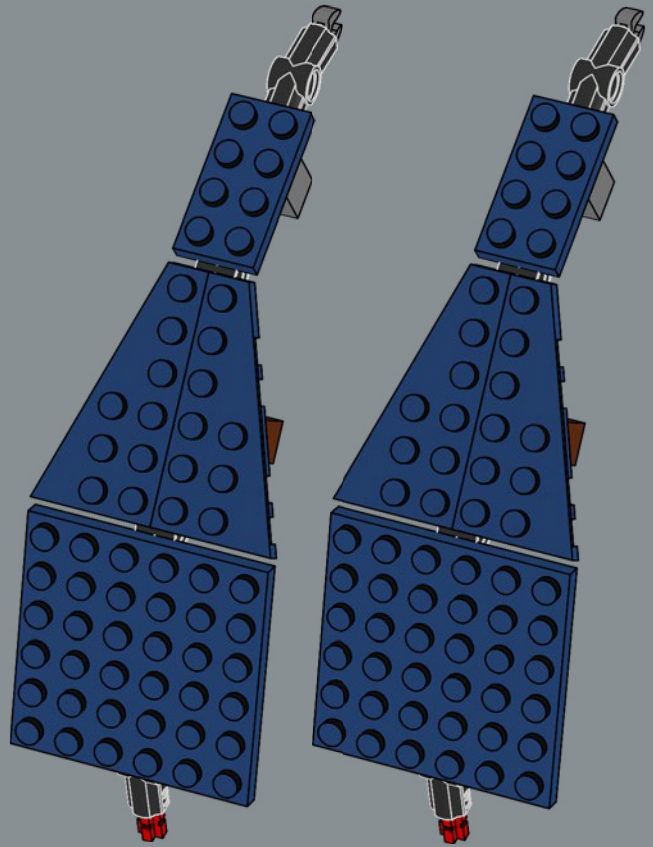

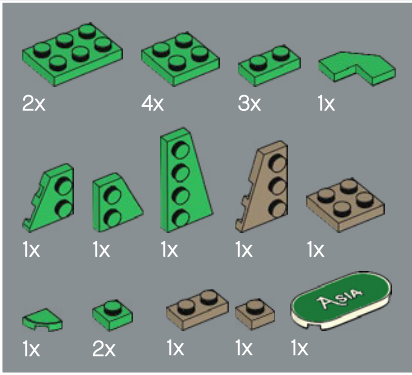
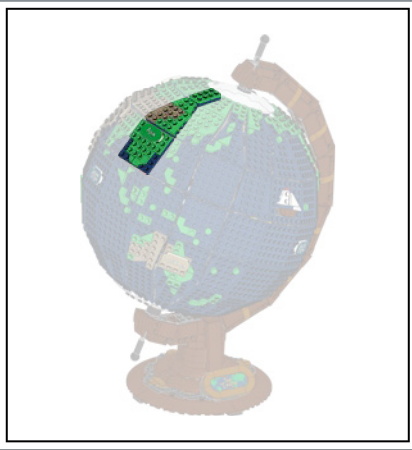

217

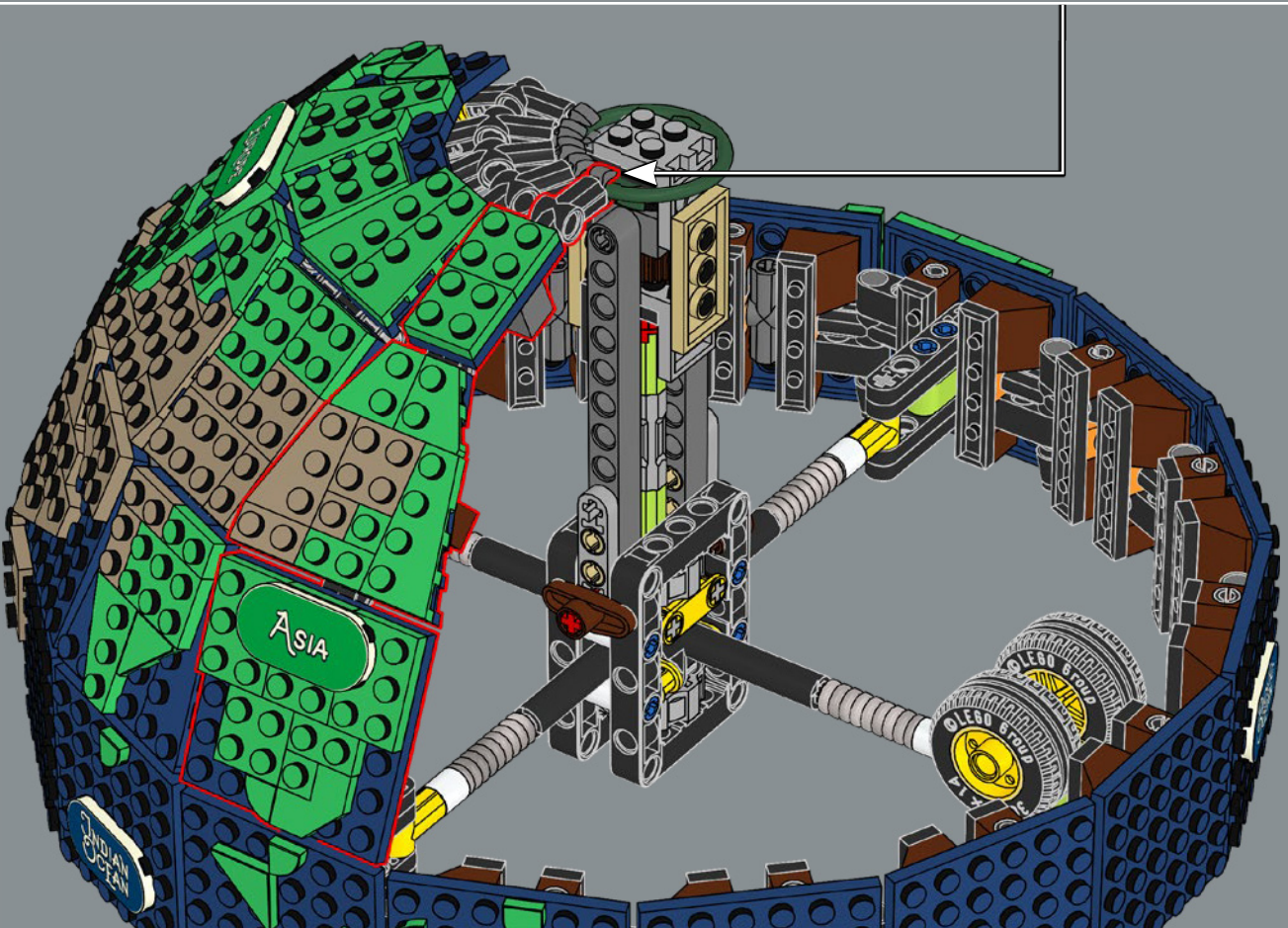
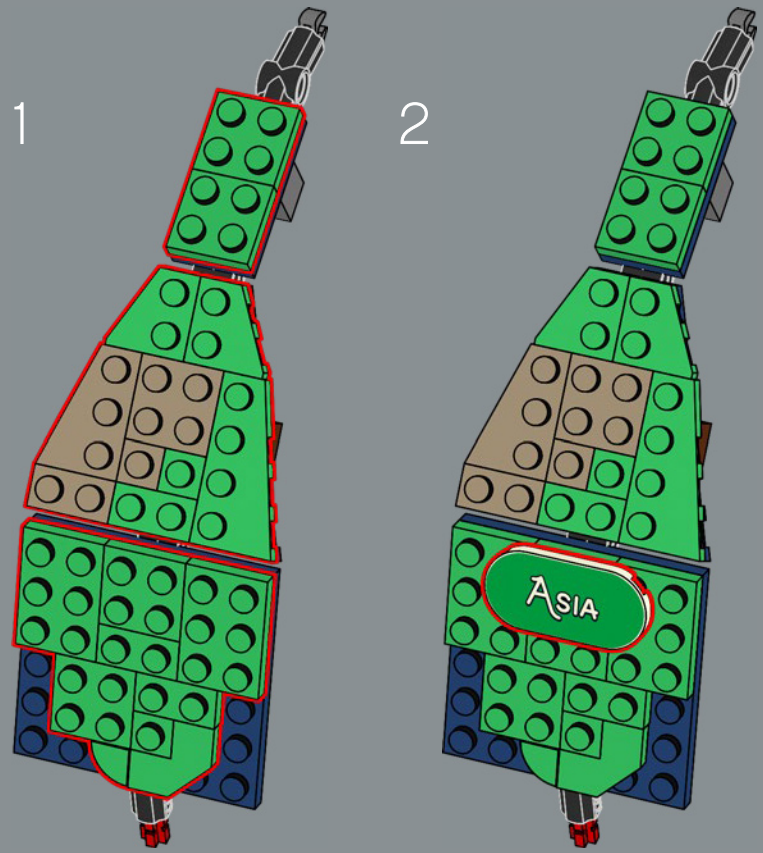

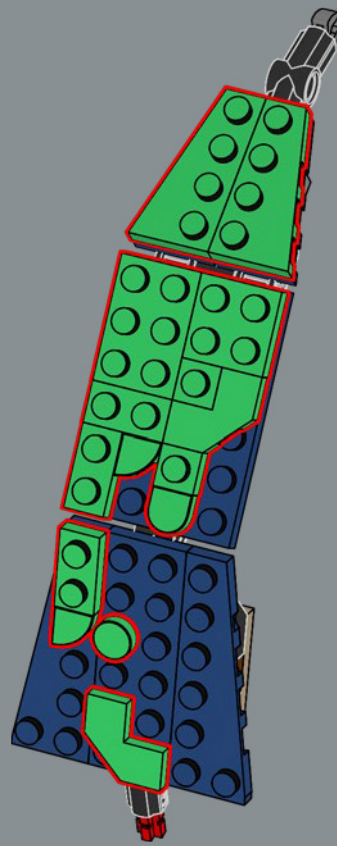
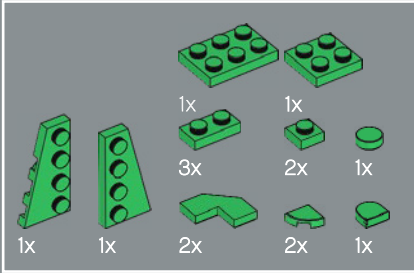
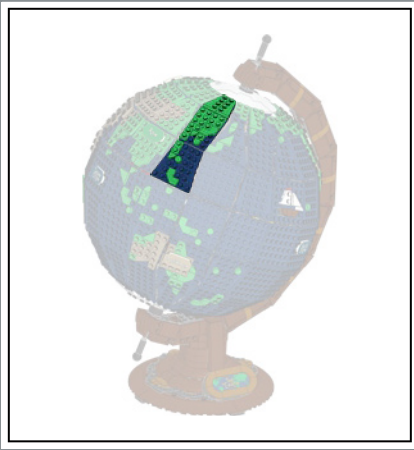

218

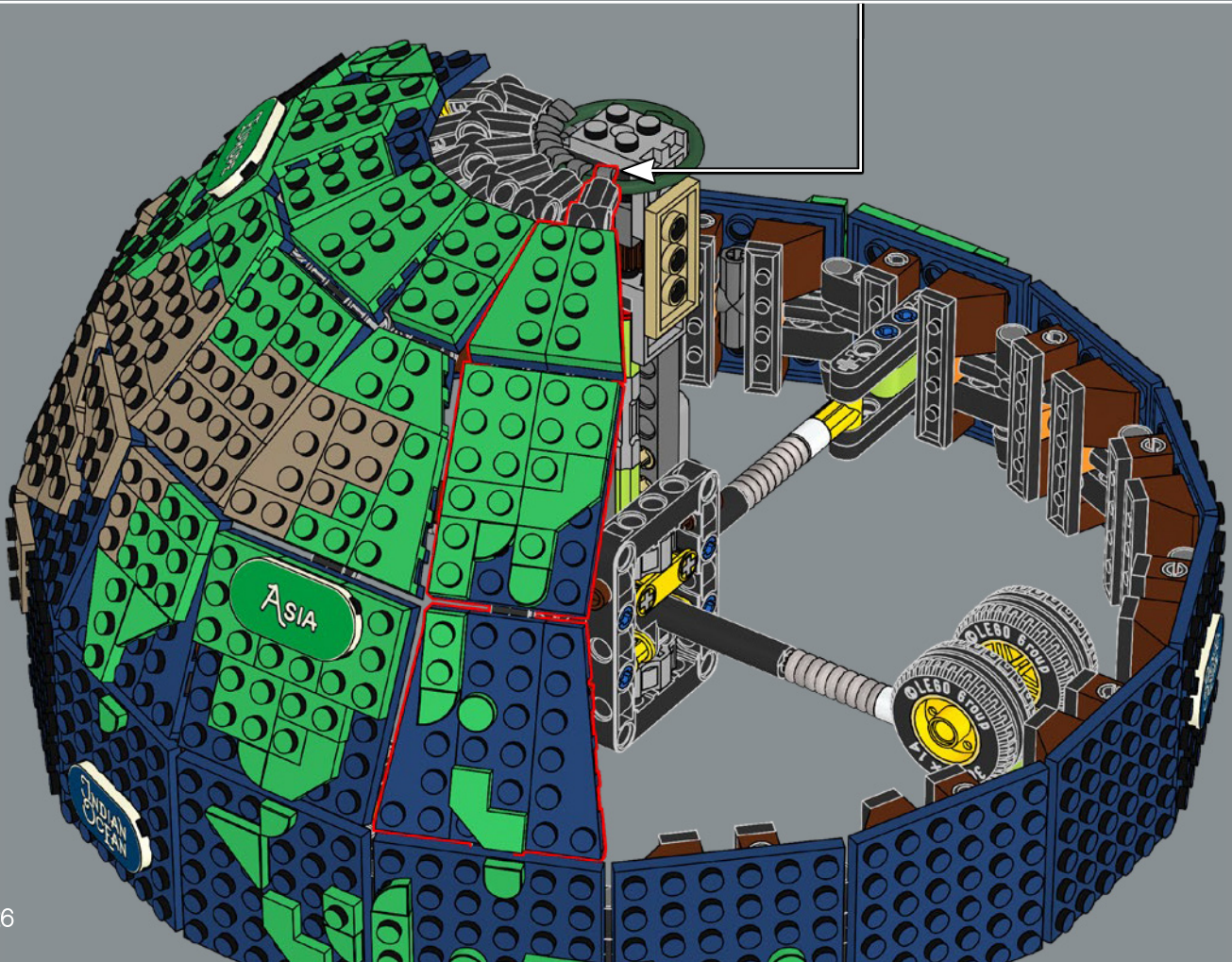

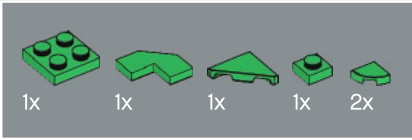
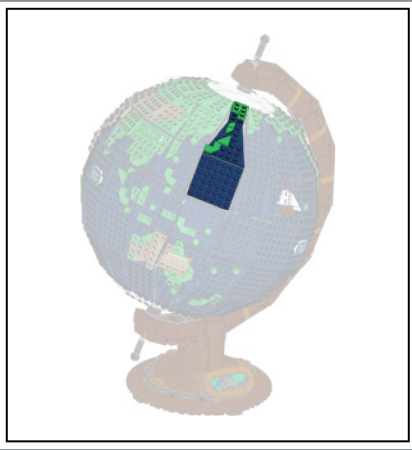

219

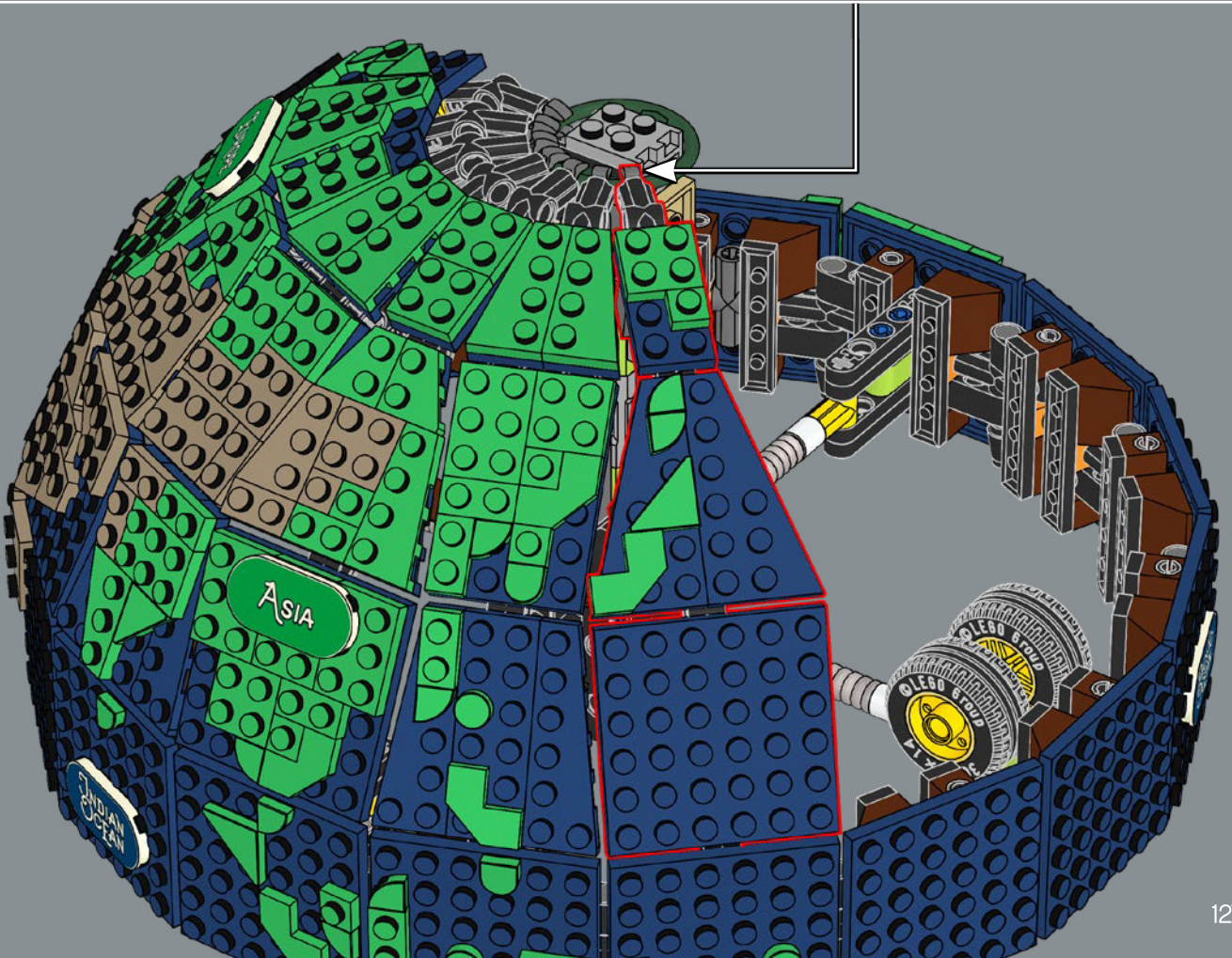
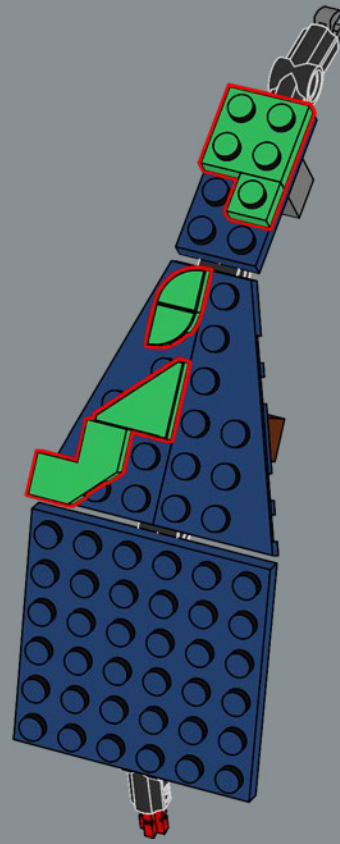

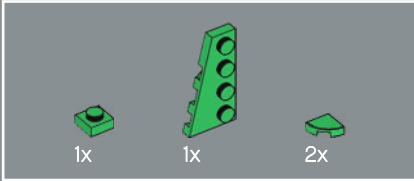
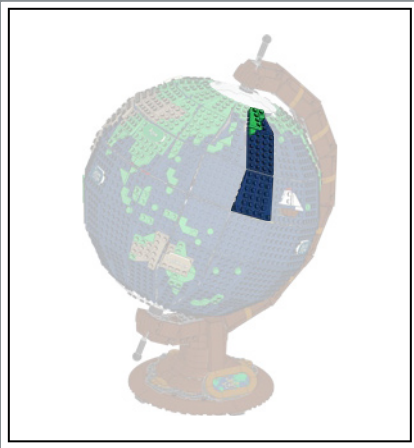

220

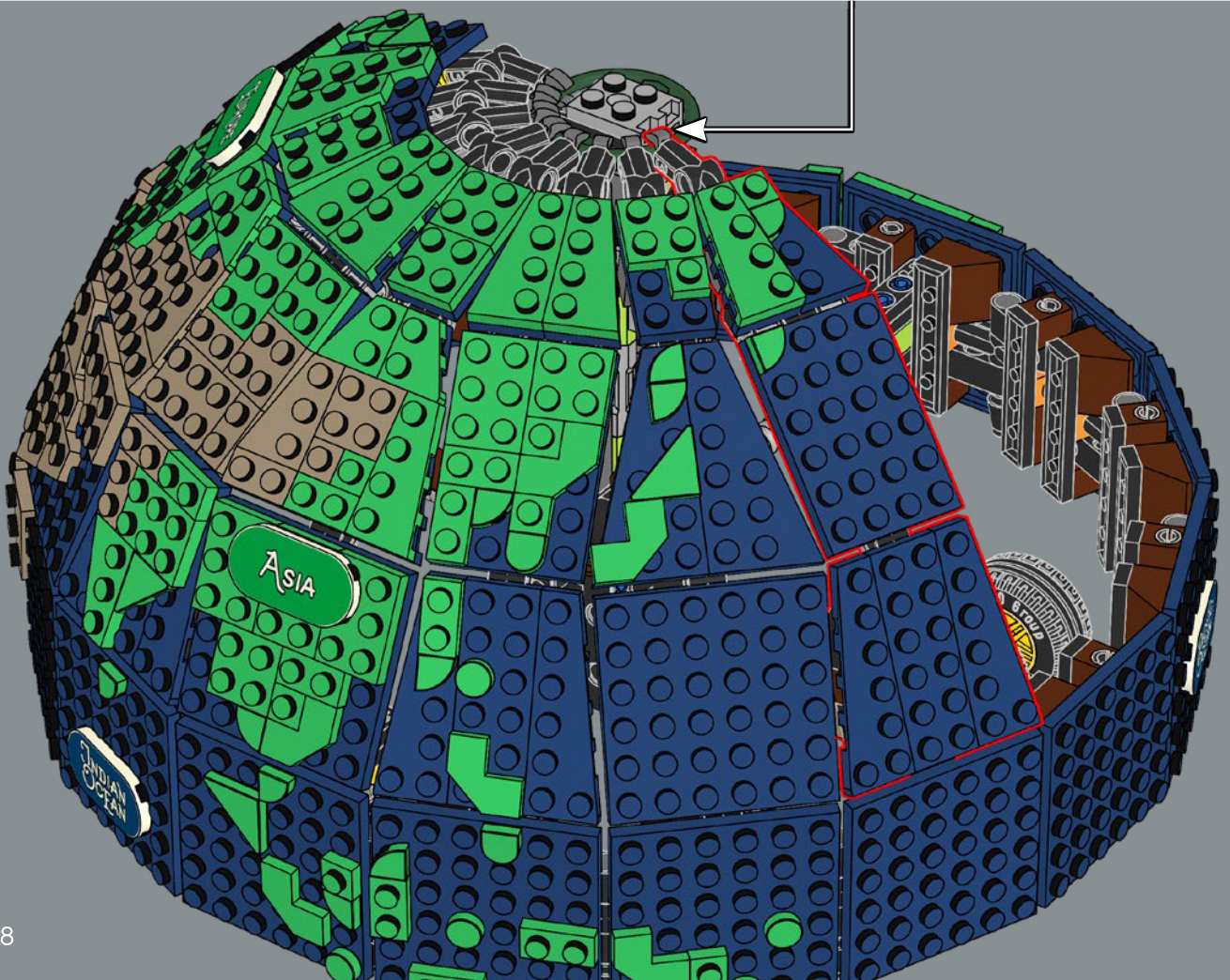
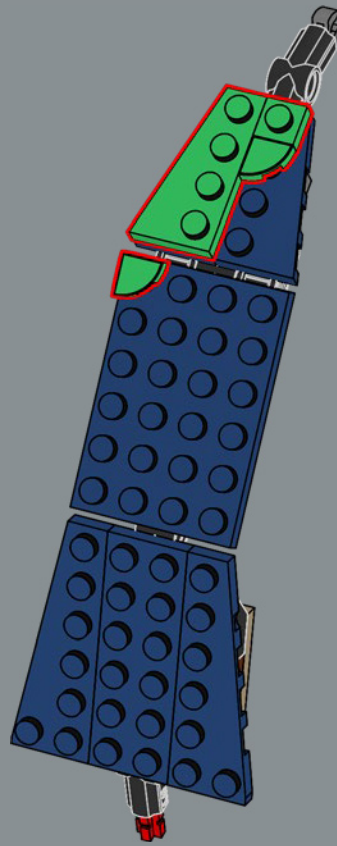

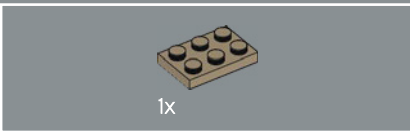
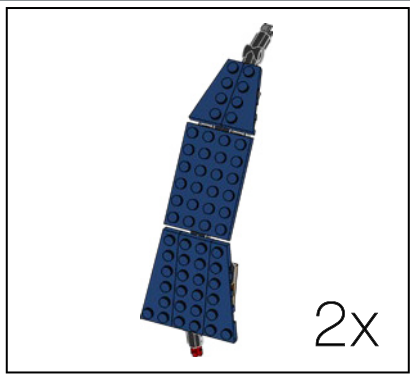
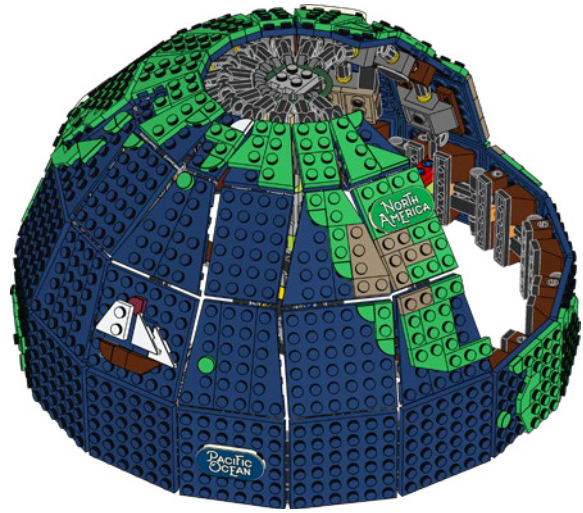

221

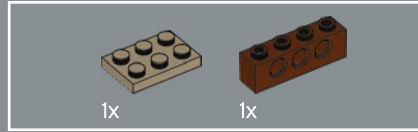

222

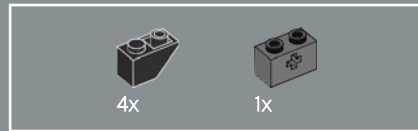
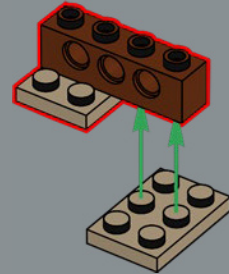

223

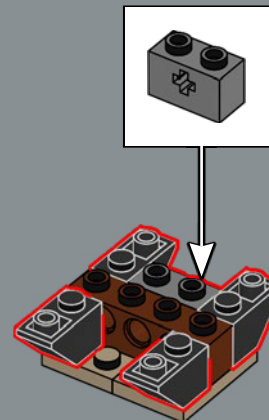

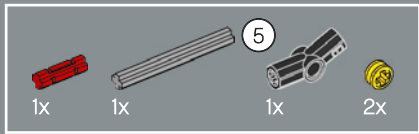

224

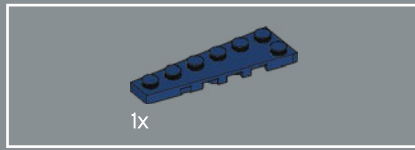
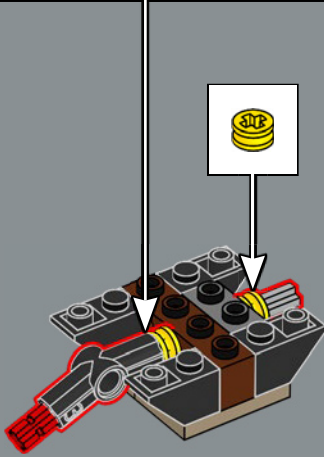
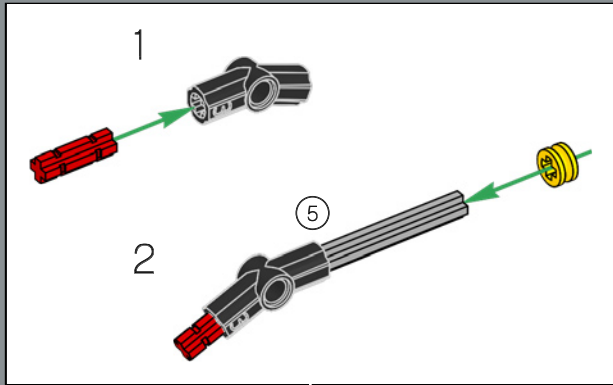

225

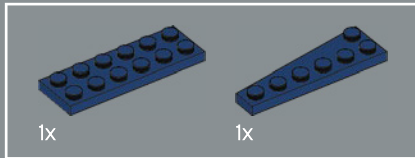
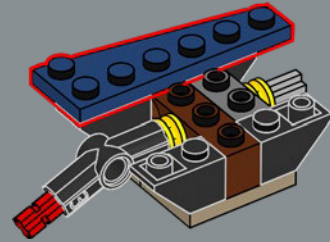

226

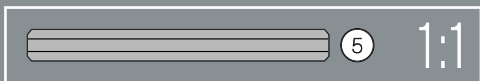
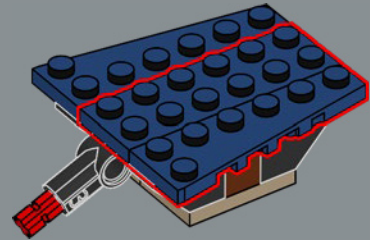

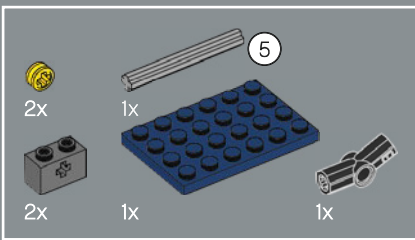

227

1

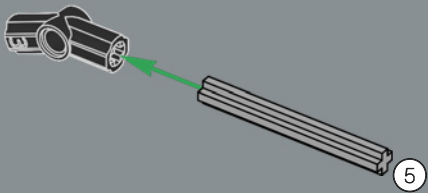

2

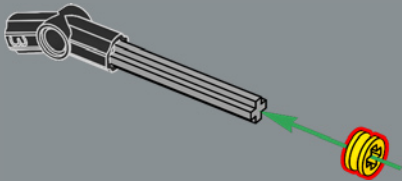

3

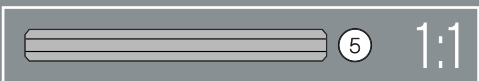
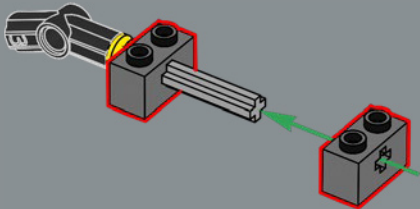

4

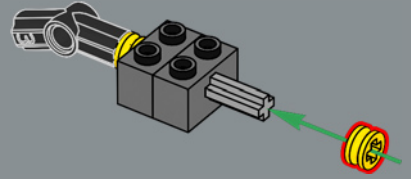

5

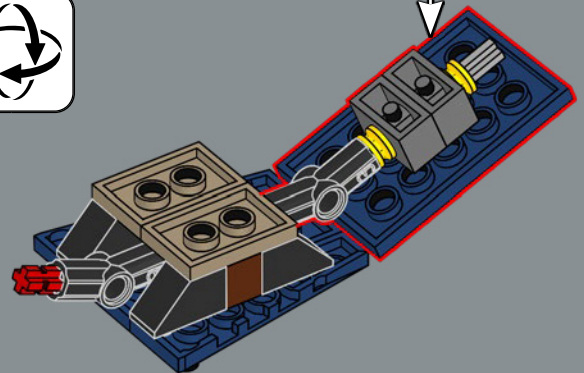
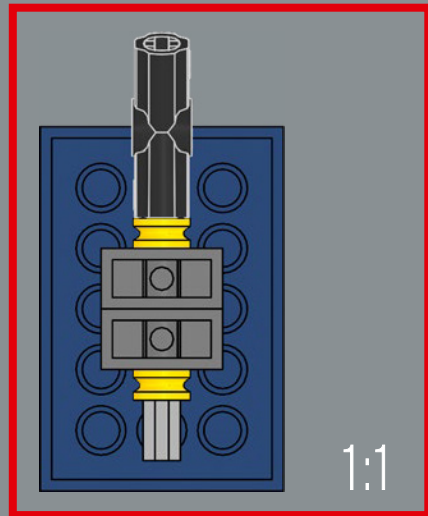
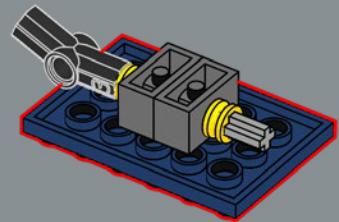

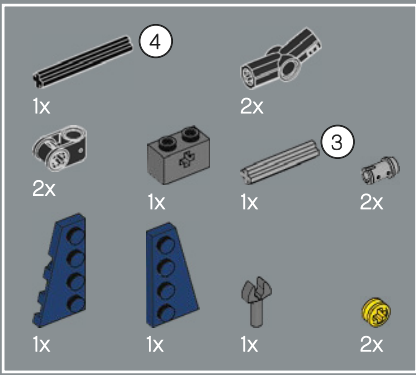

228

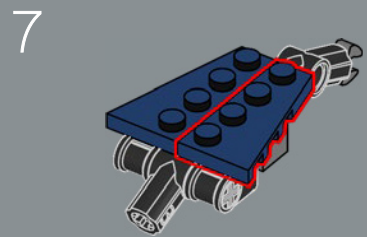
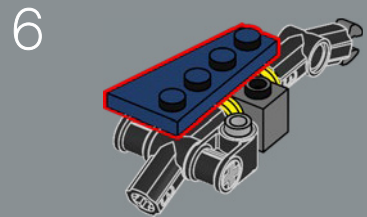
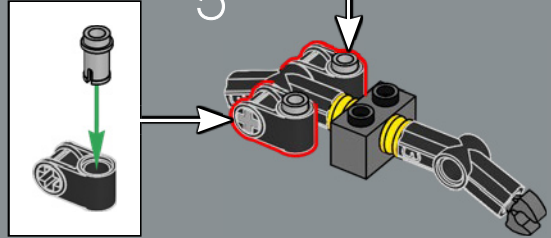
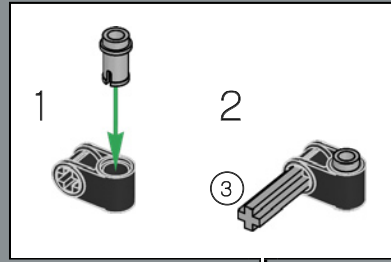
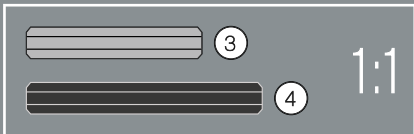
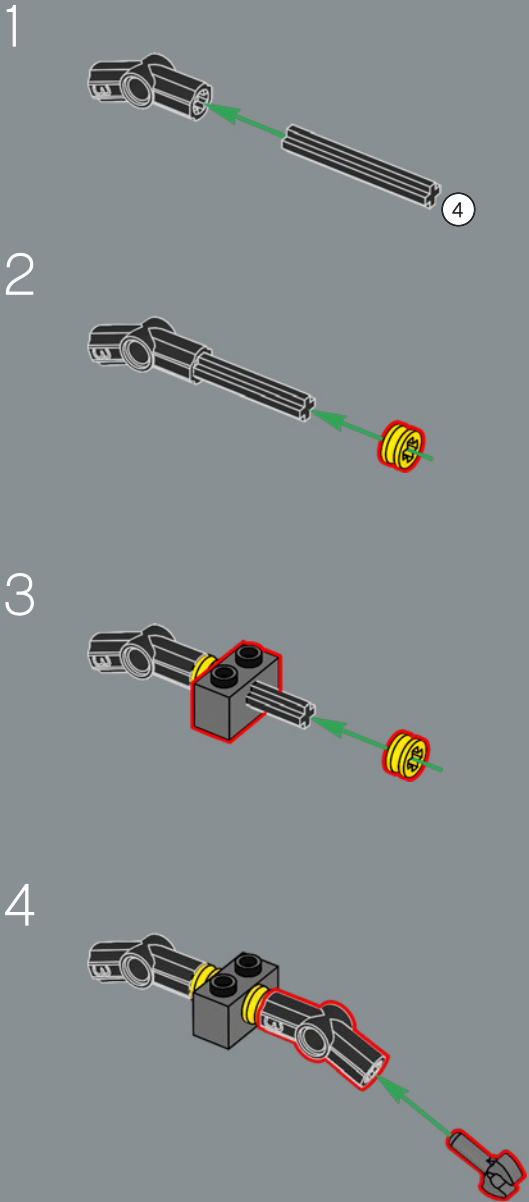

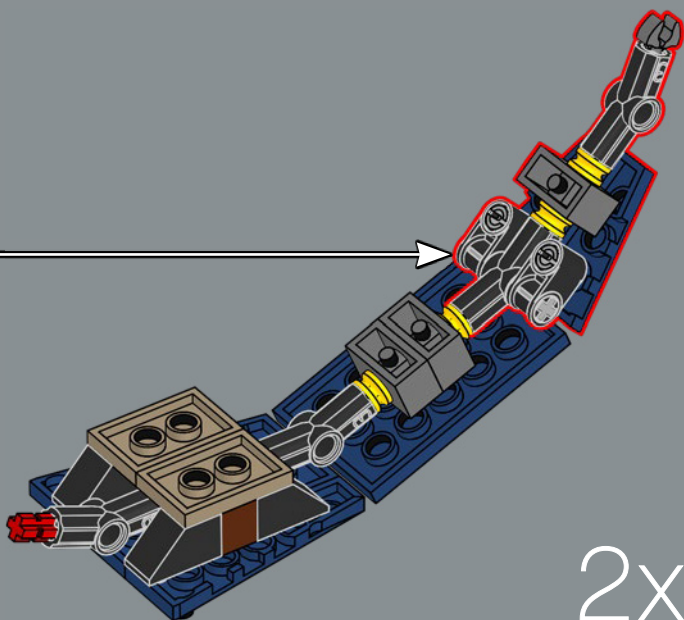
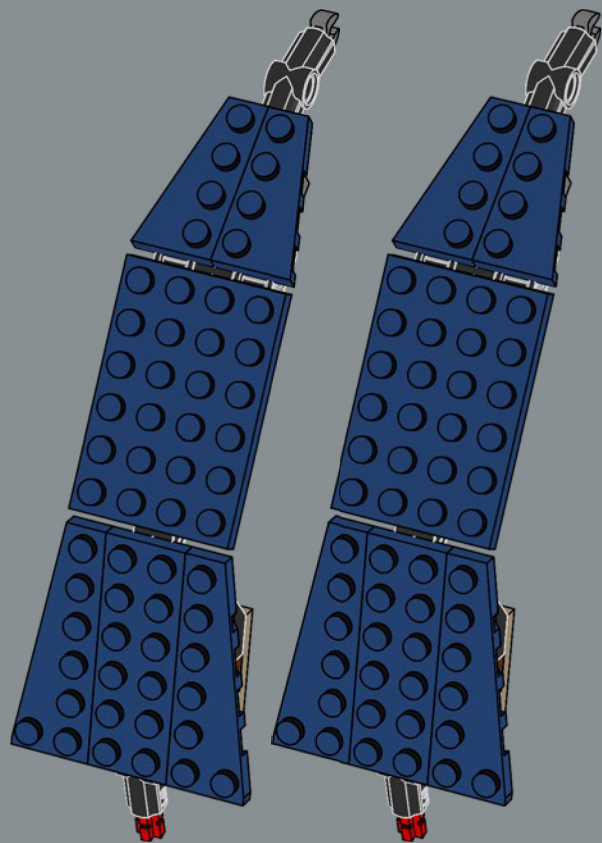

2x

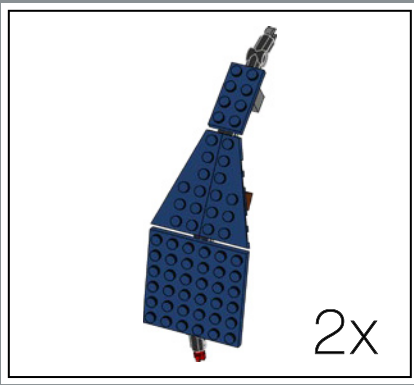

2x

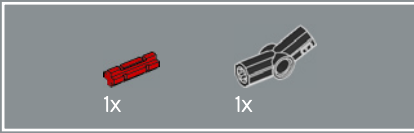

1x

1x

229

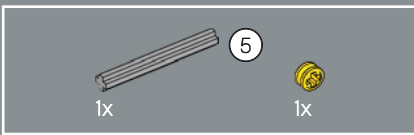
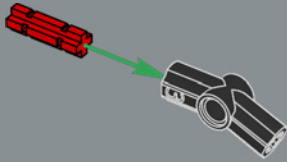

1x

1x

5

230

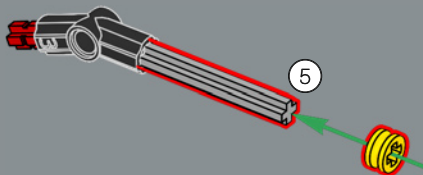

5

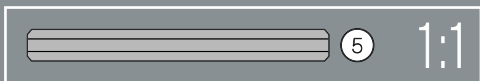

1x

5 1:1

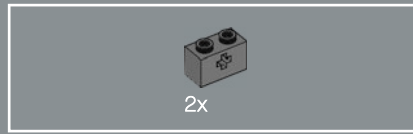

2x

231

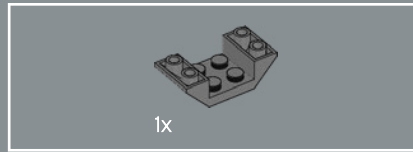
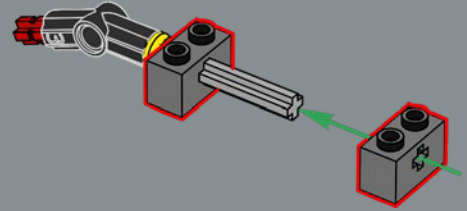

1x

232

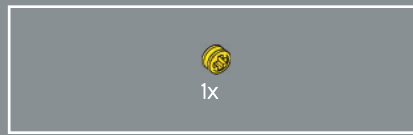
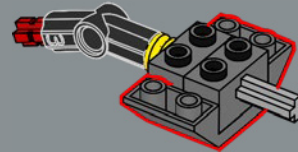

1x

233

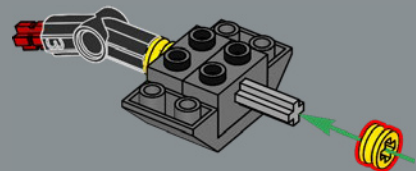



234

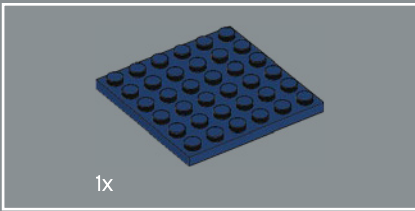
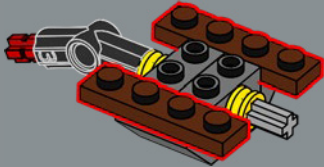

235

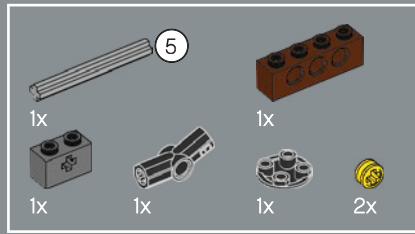
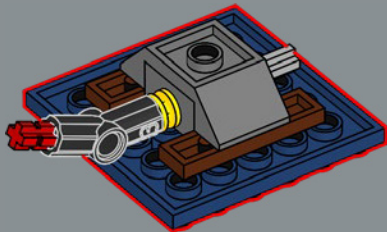

236

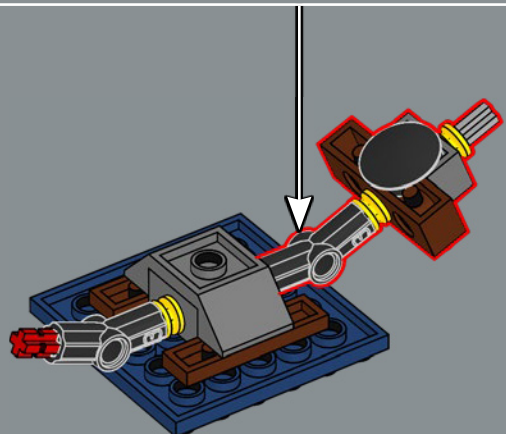
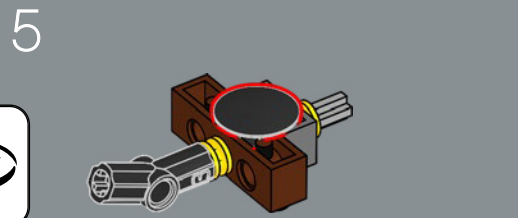
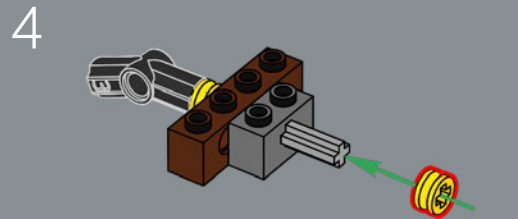
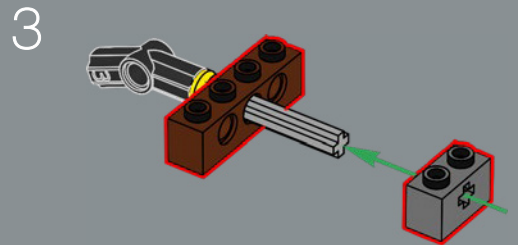
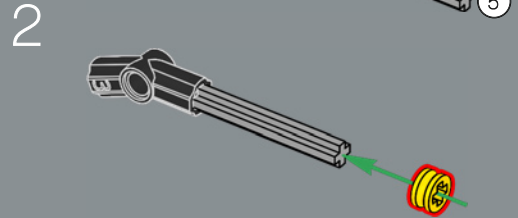
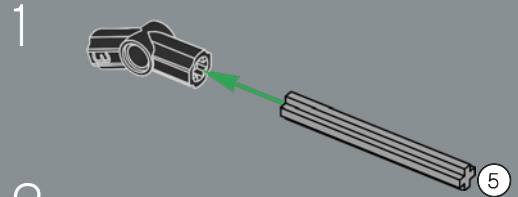

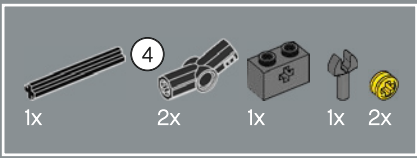

237

1

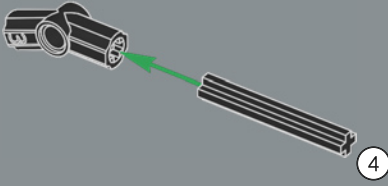

2

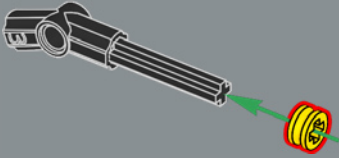

3

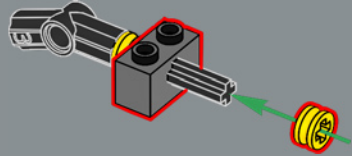

4

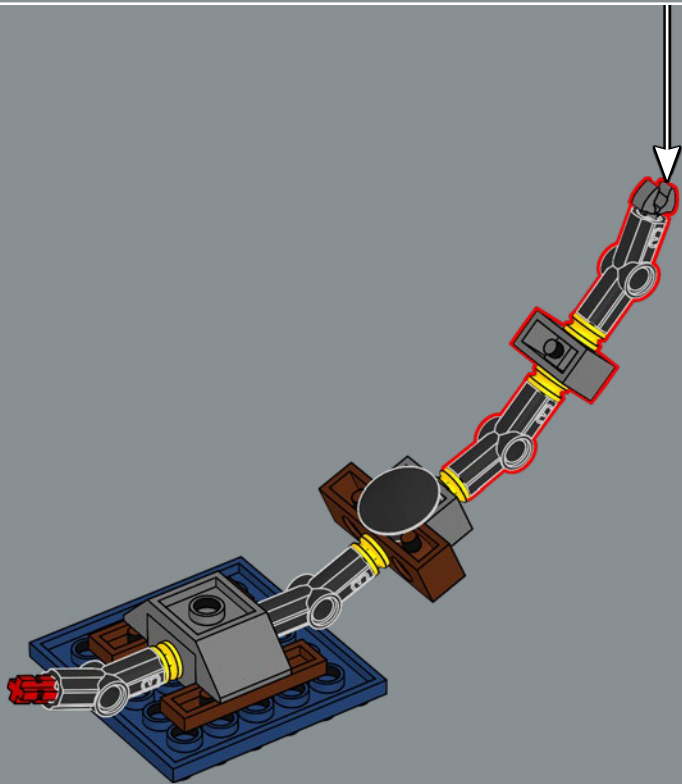
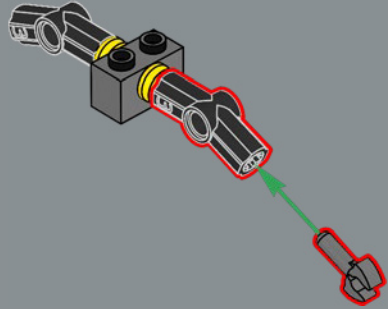

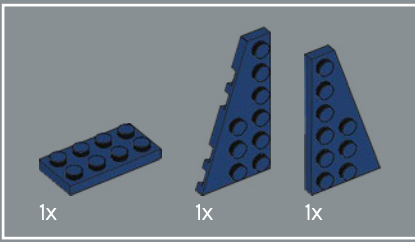

238

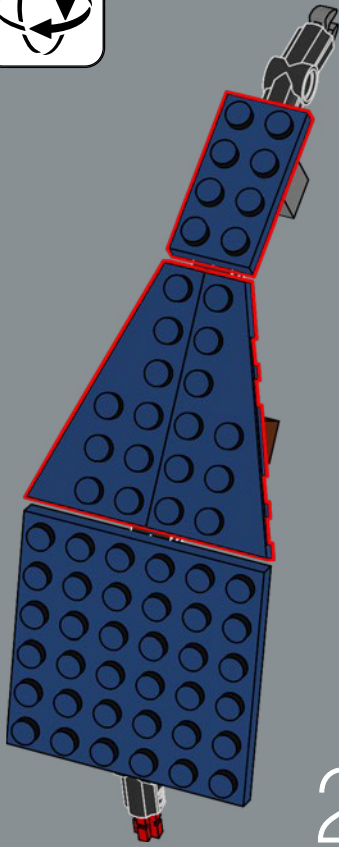

2x

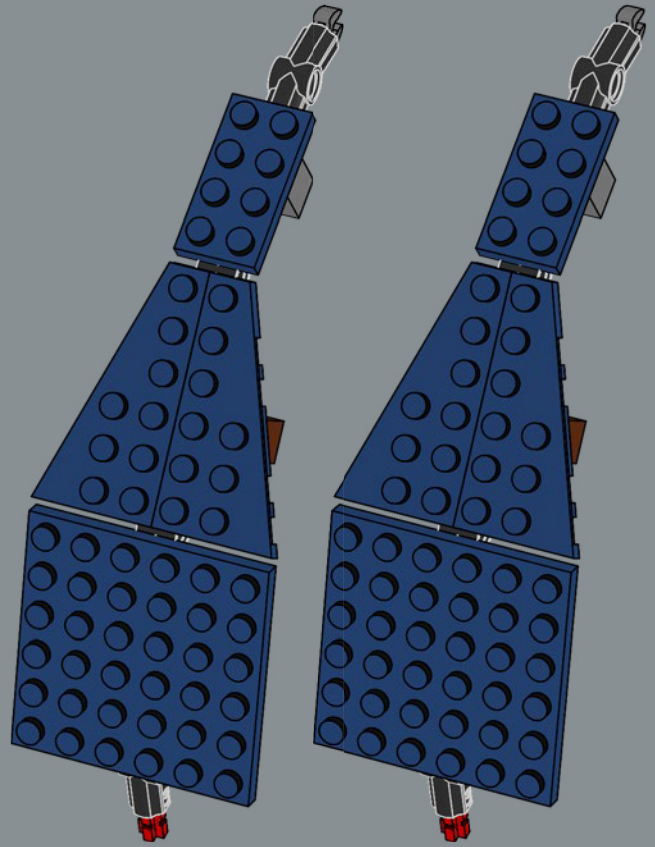

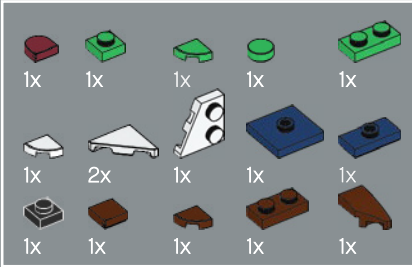
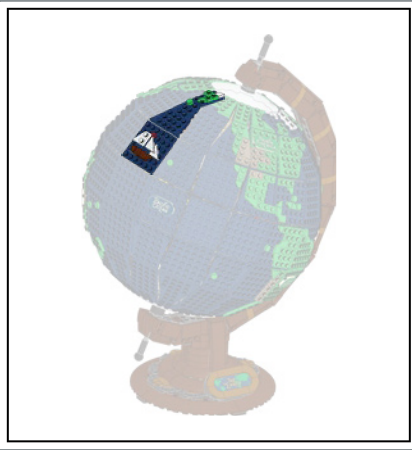

239

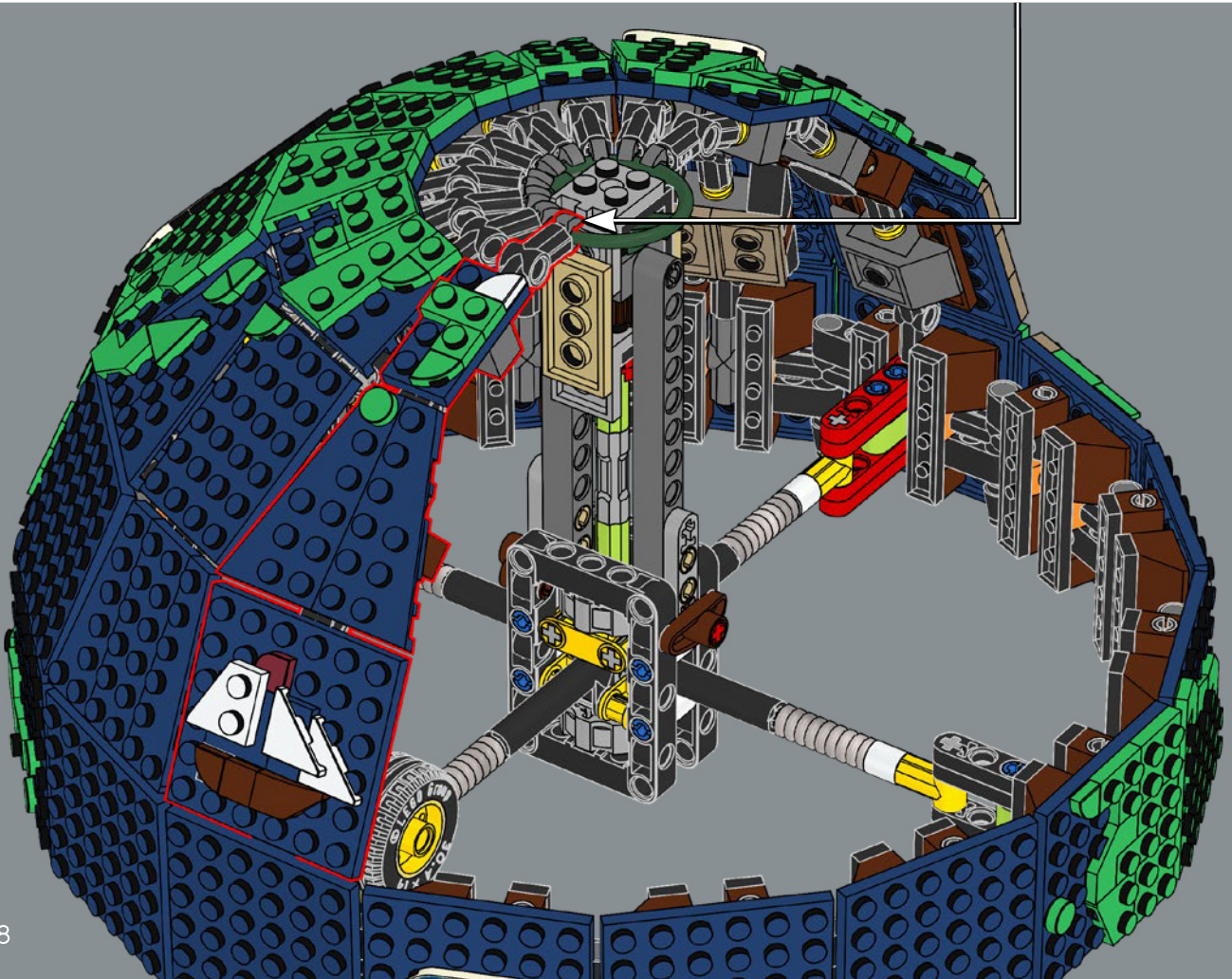
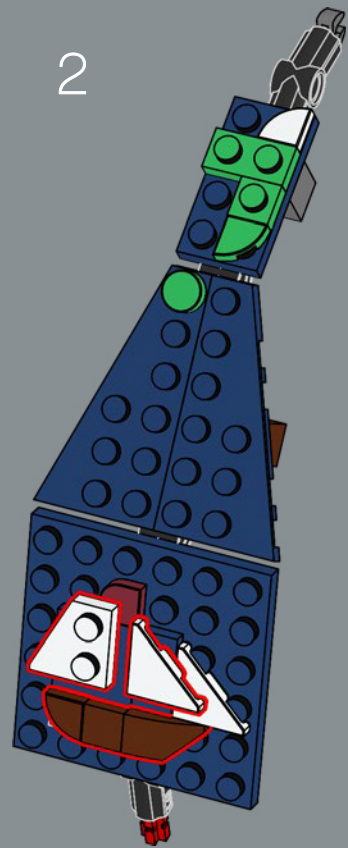
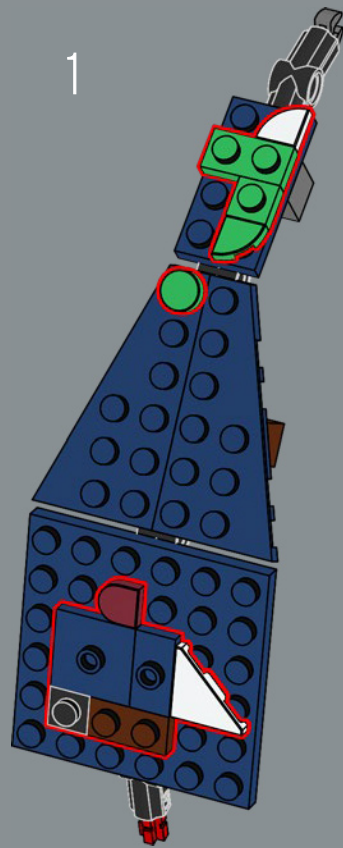

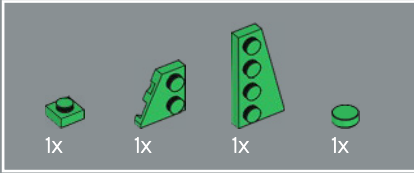
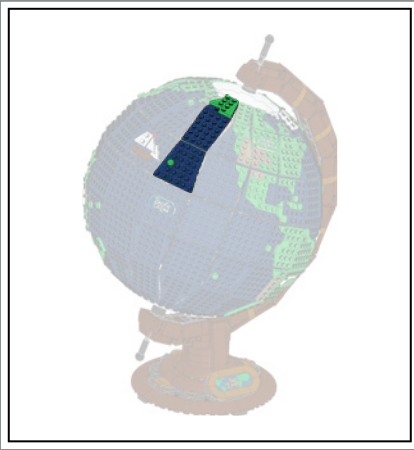

240

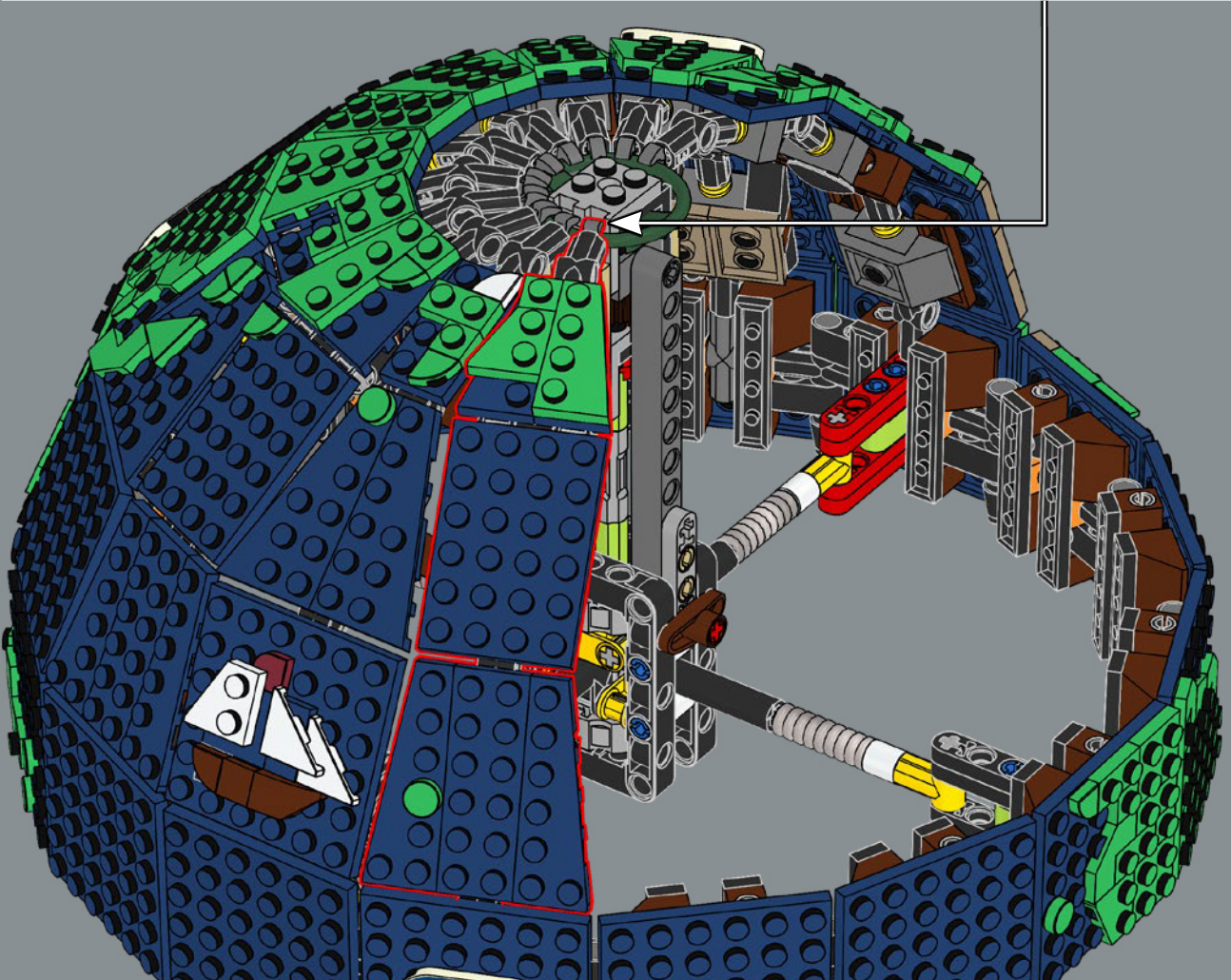

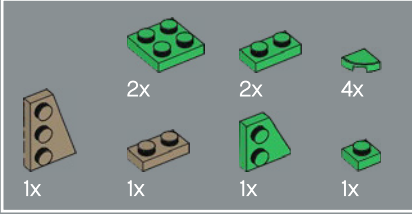
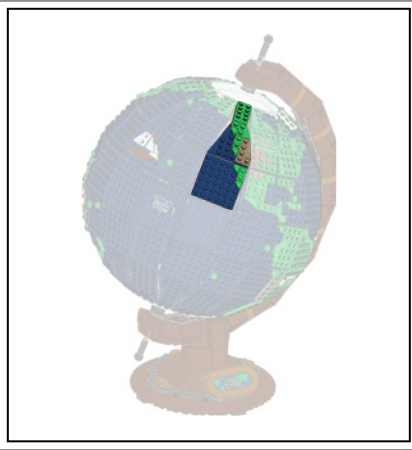

241

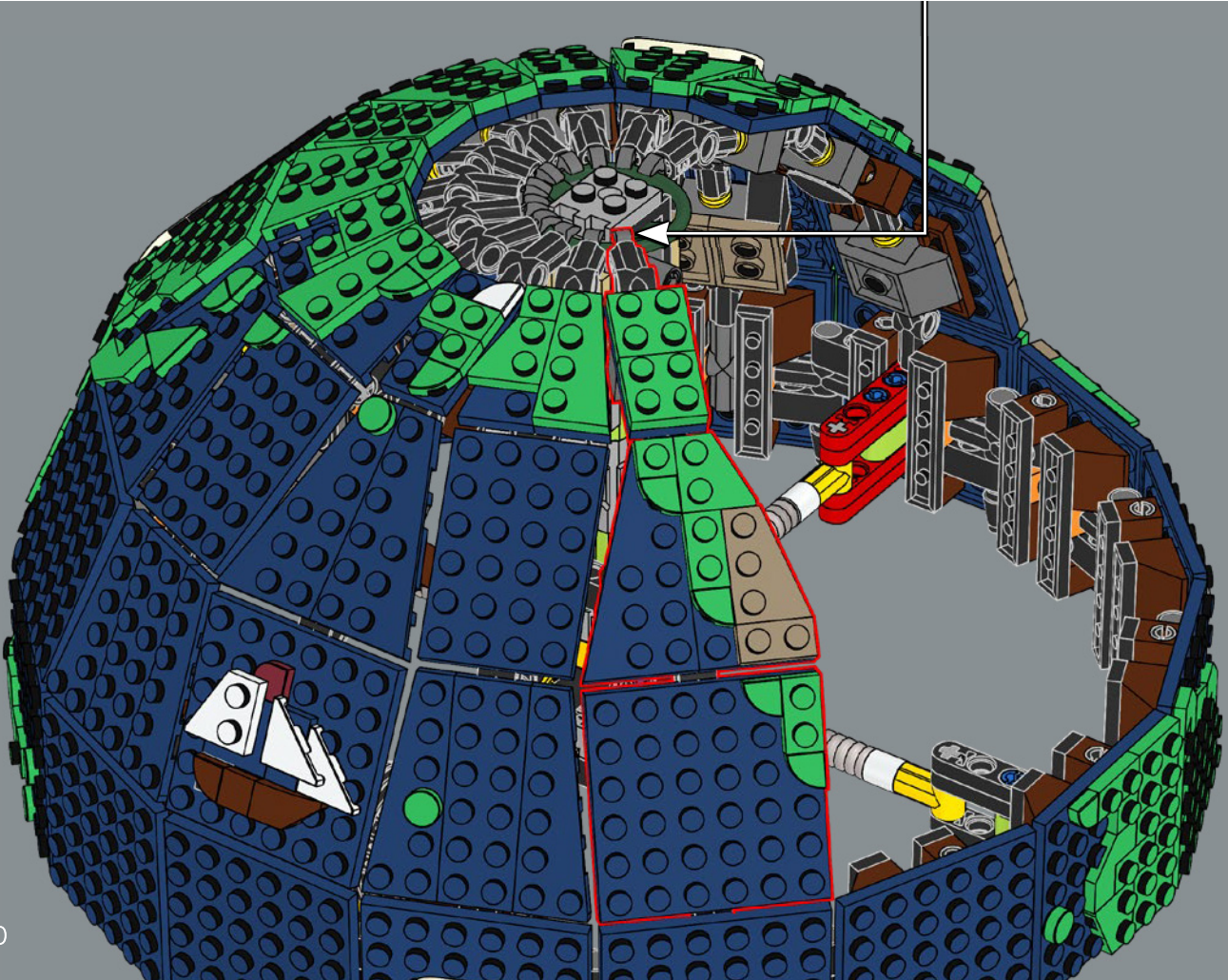
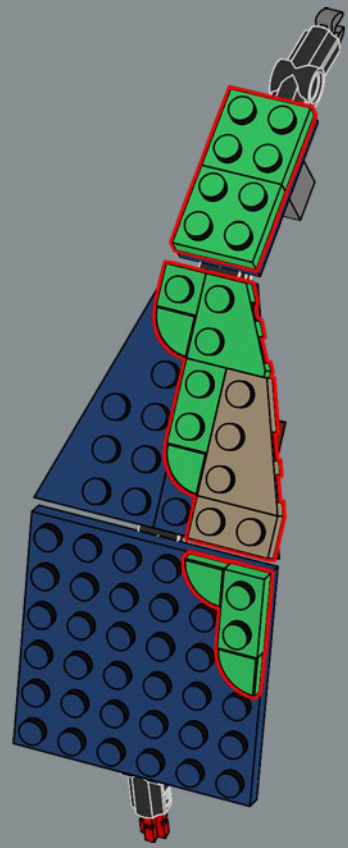

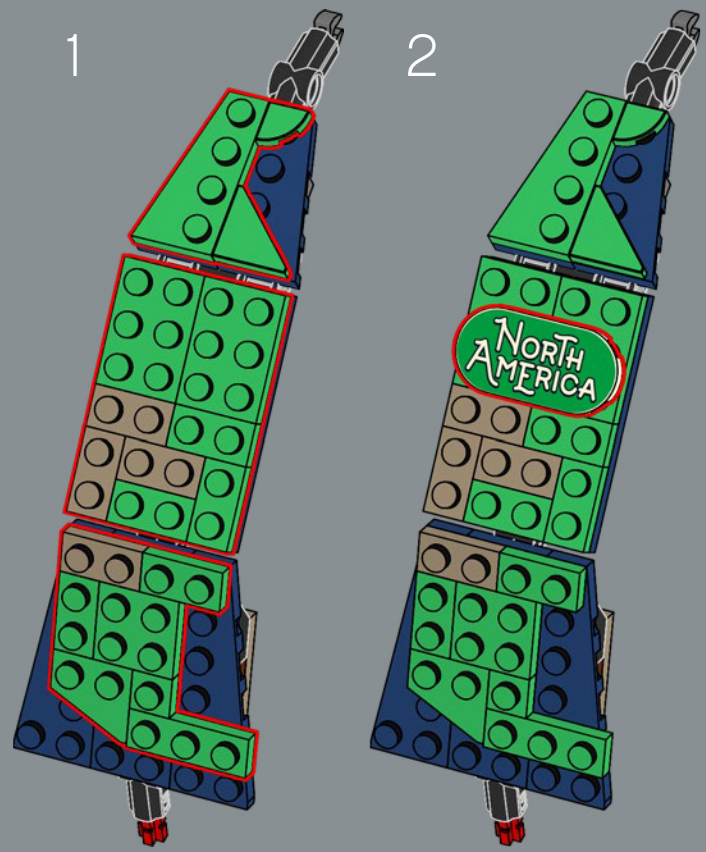
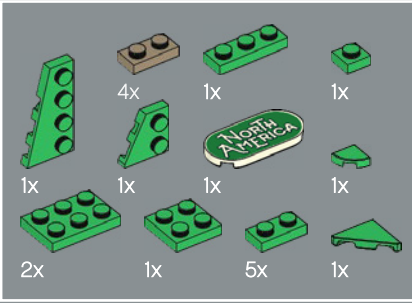
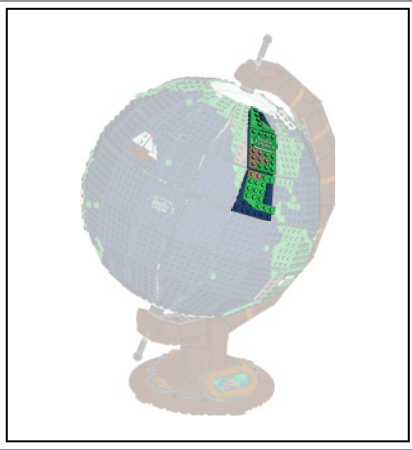

242

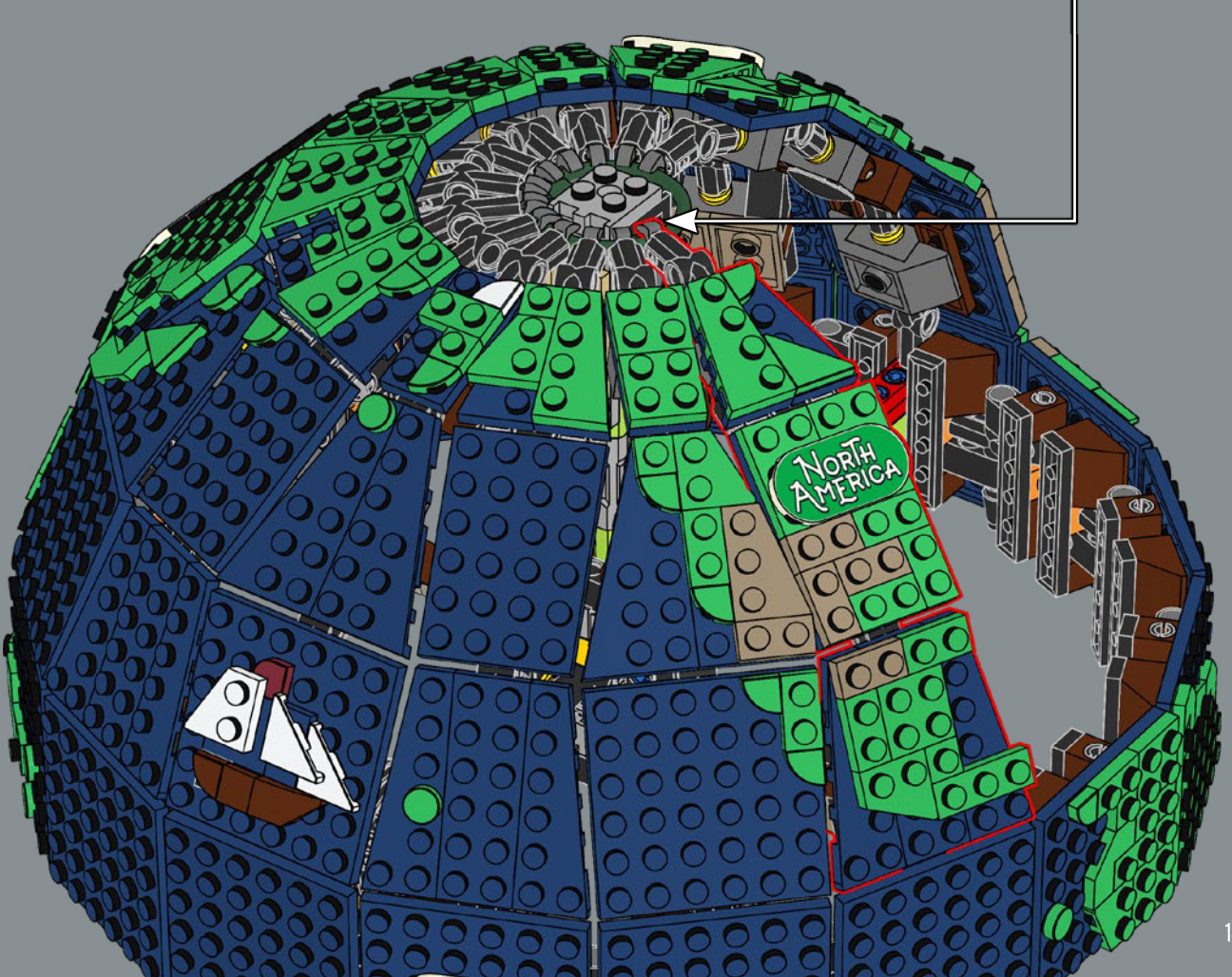

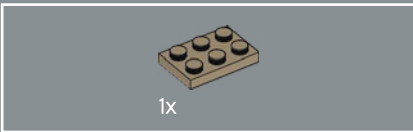
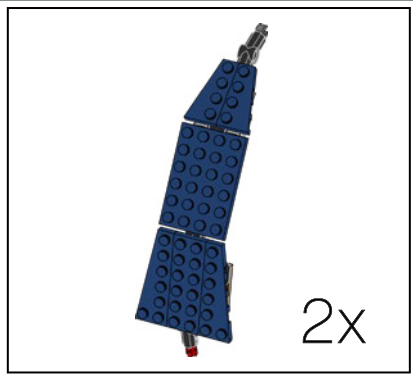
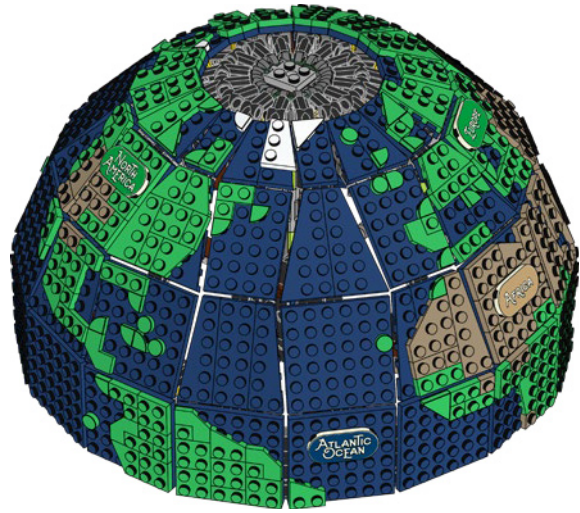

243



244

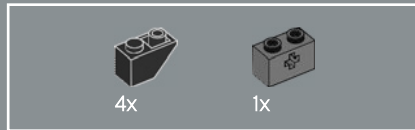
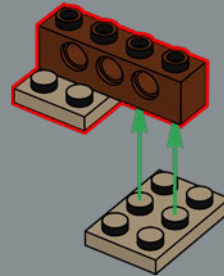

245

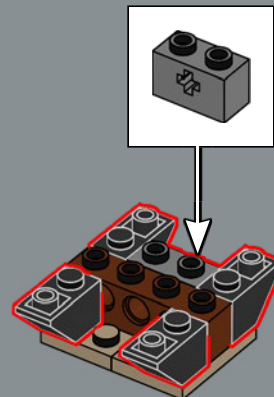

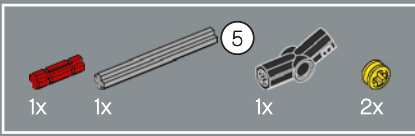

246

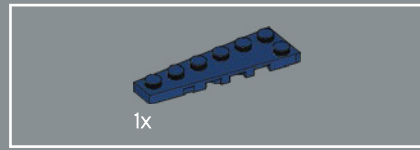
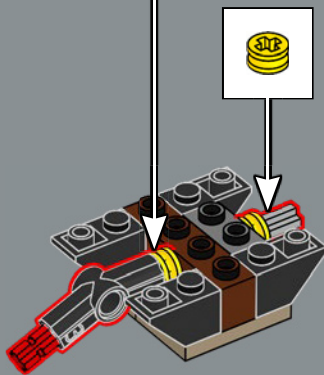
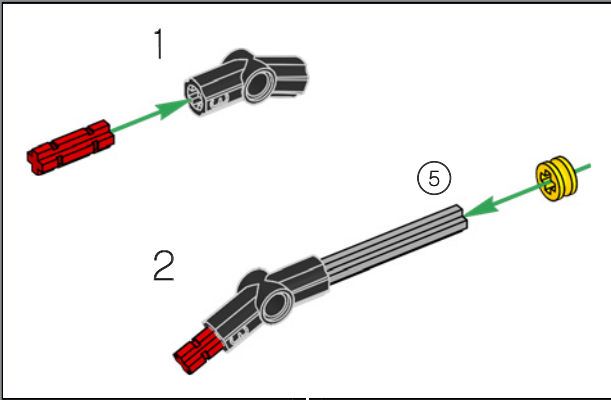

247

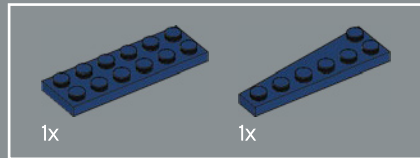
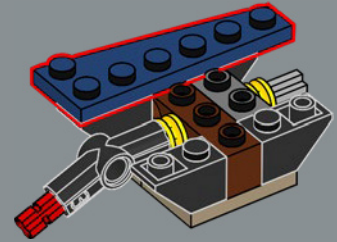

248

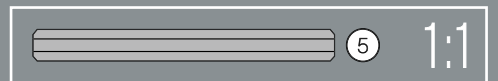
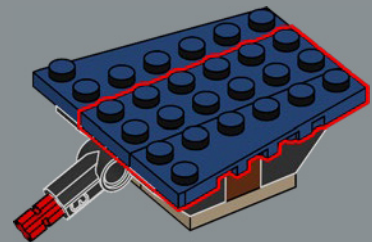

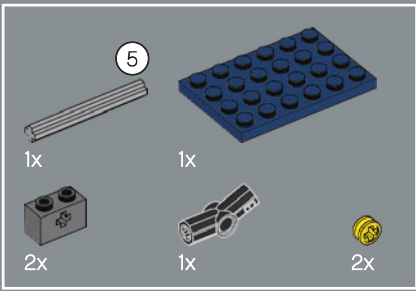

249

1

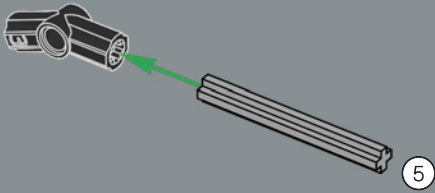

2

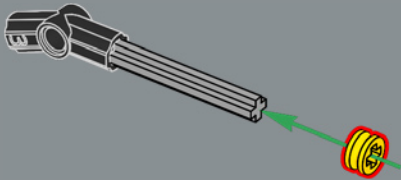

3

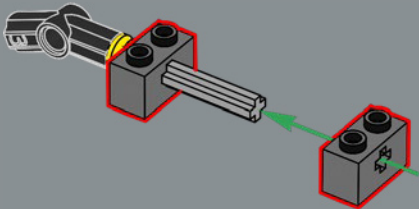

4

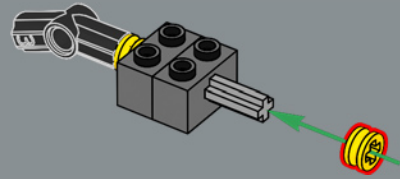

5

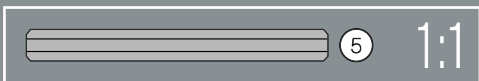
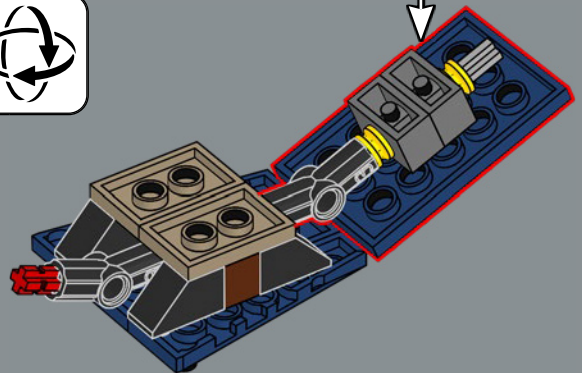
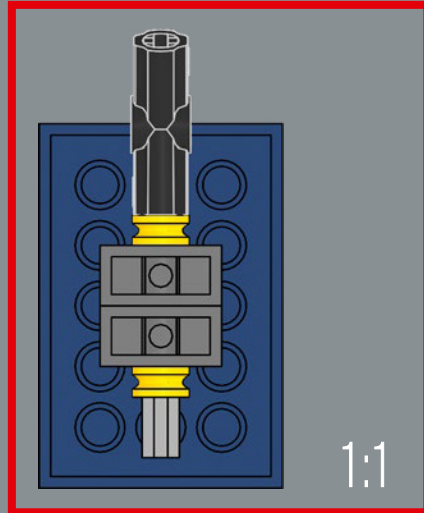
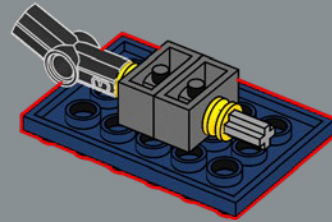

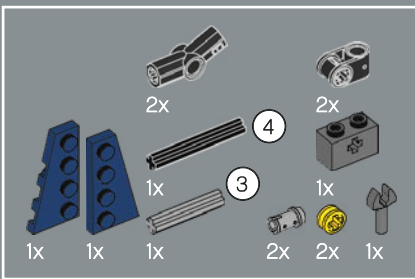

250

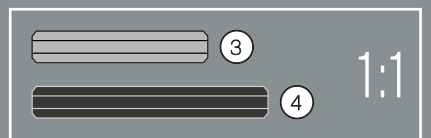
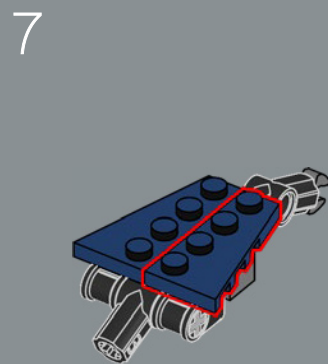
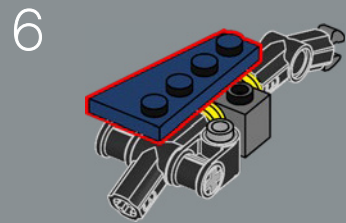
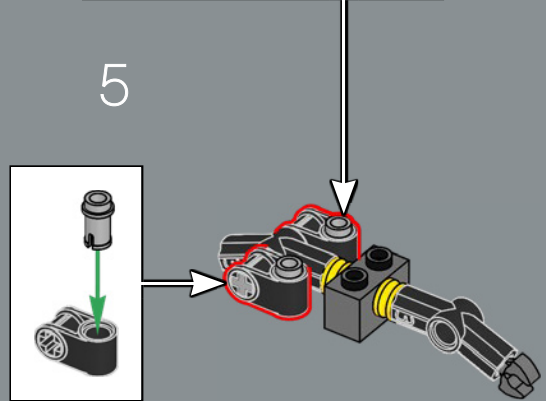
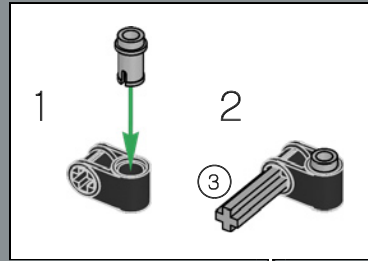
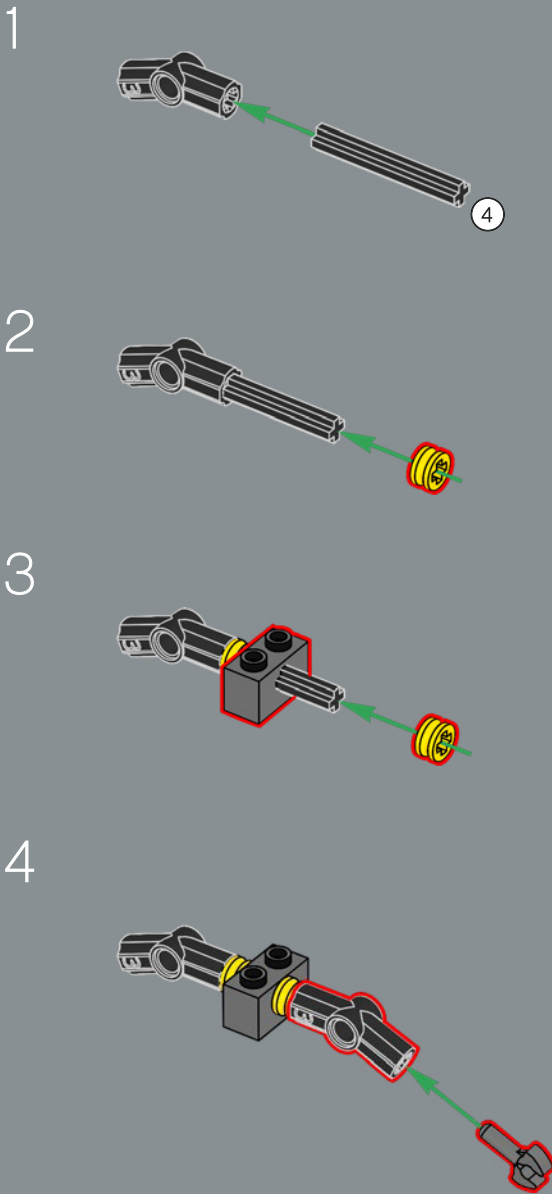

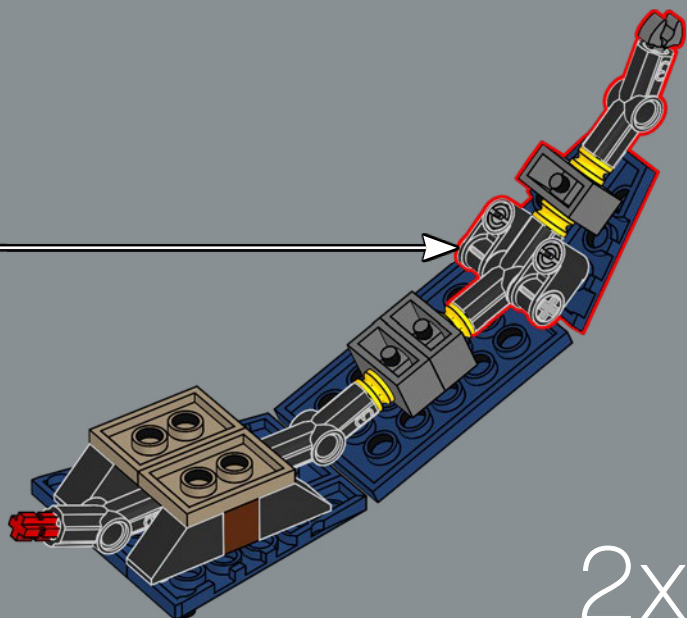

2x

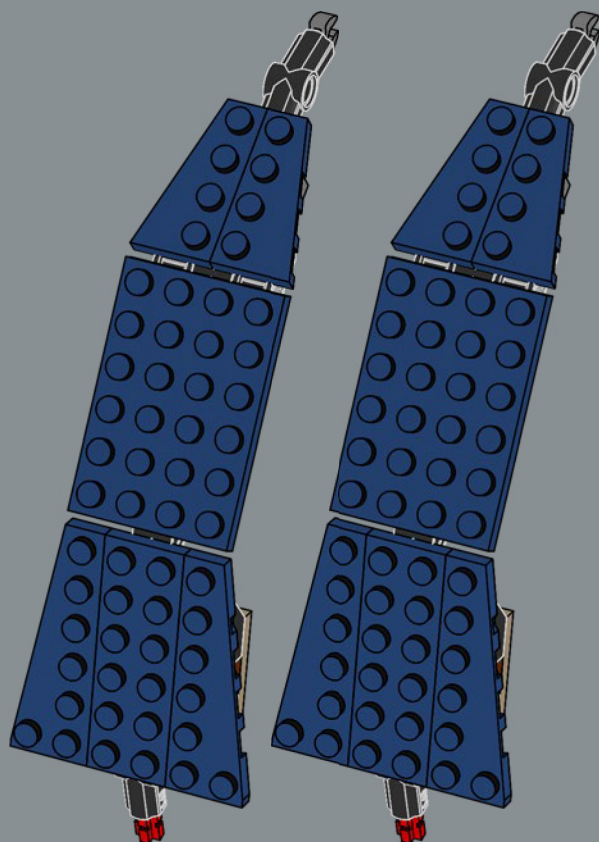

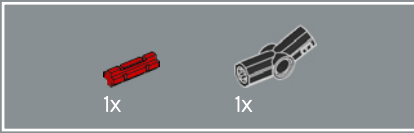
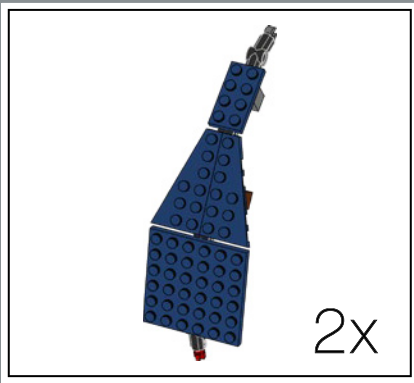

251

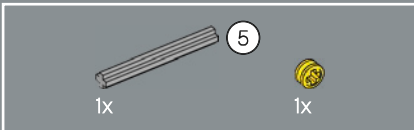
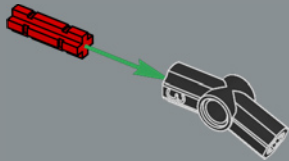

252

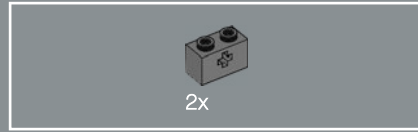
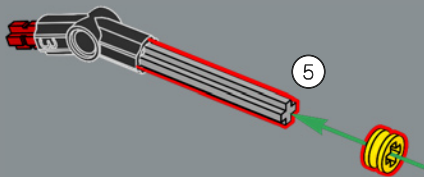

253

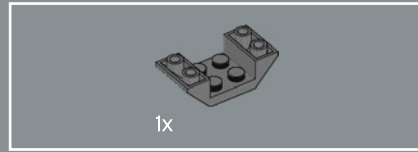
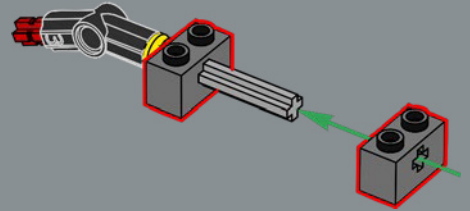

254

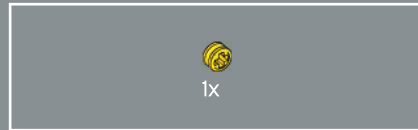
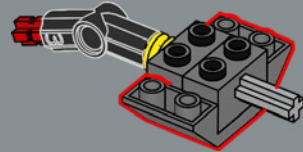

255

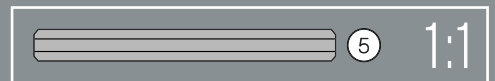
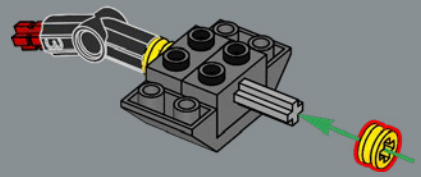

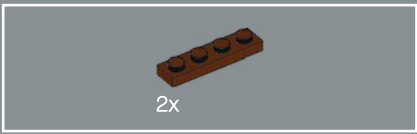

2x

256

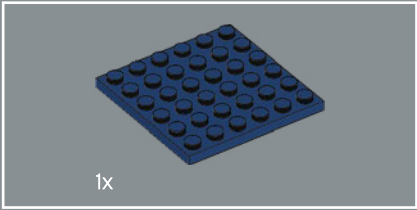
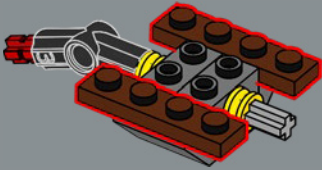

1x

257

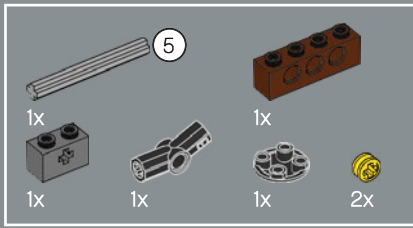
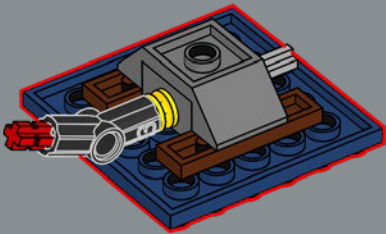

258

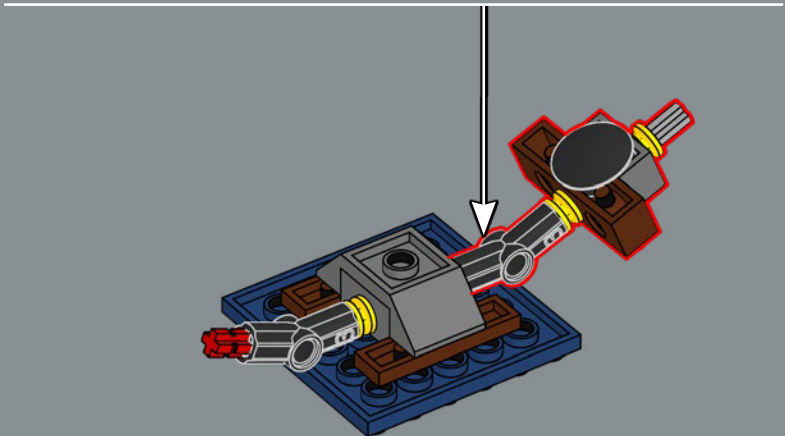
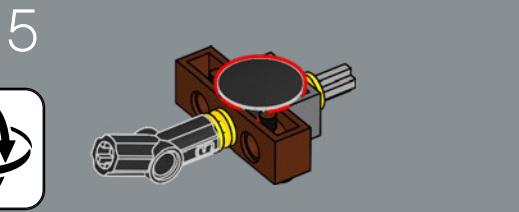
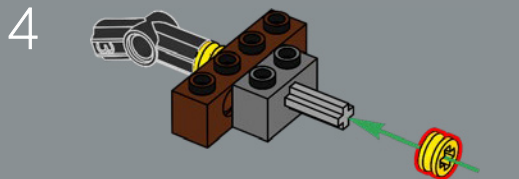
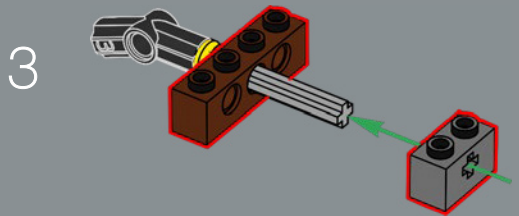
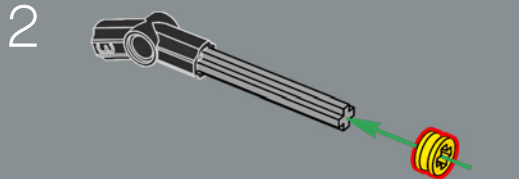
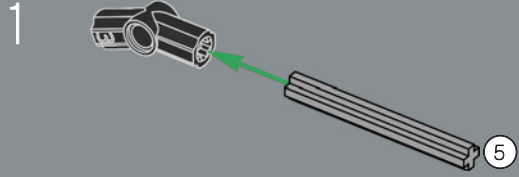



259

1

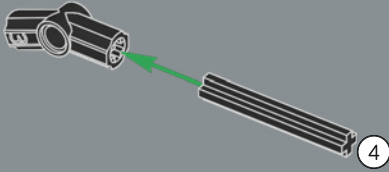

2

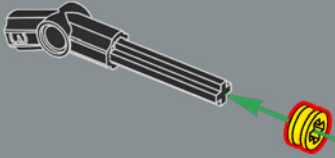

3

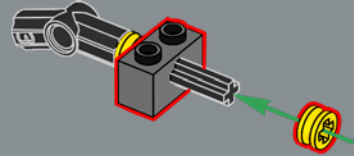

4

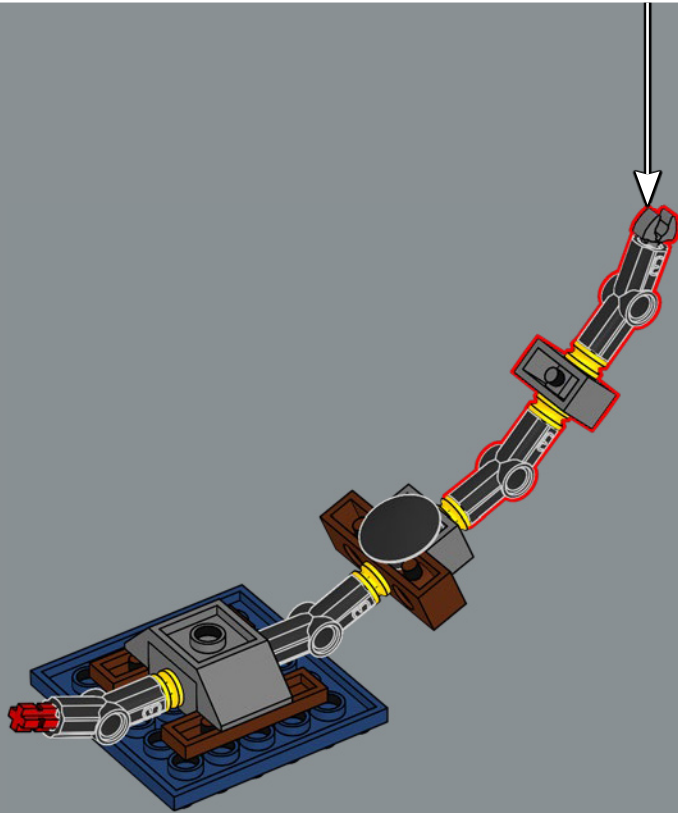
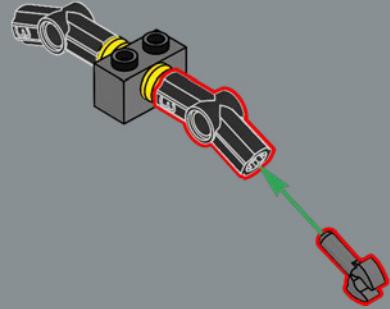

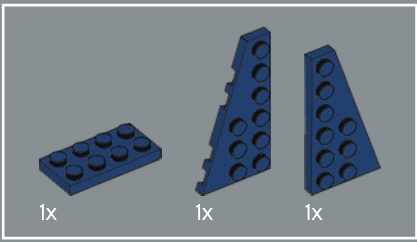

260

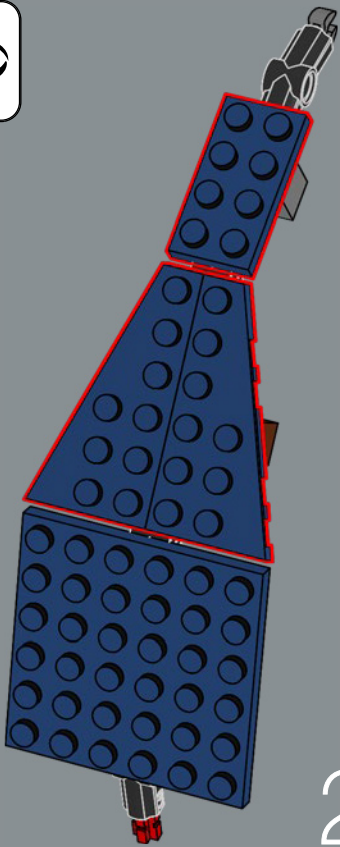

2x

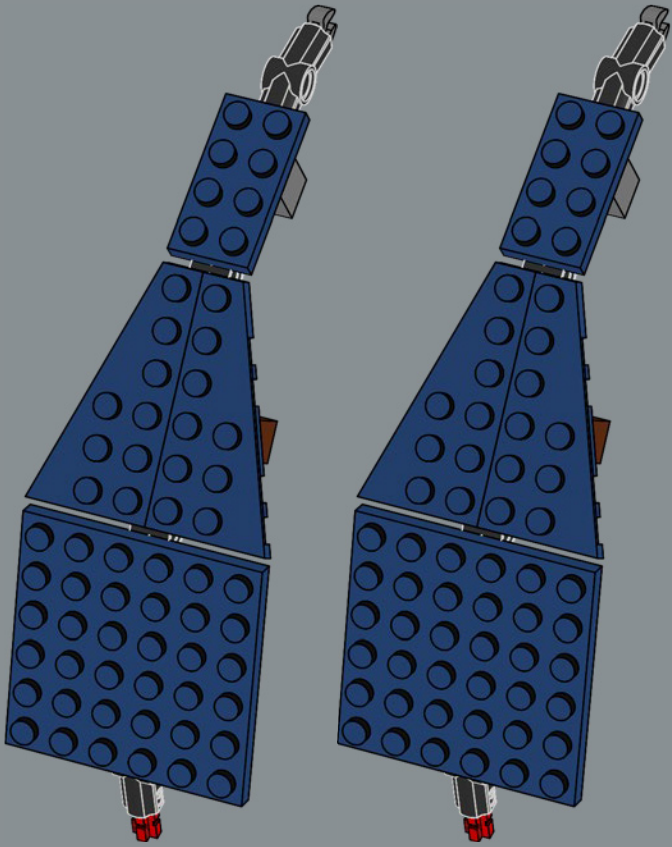

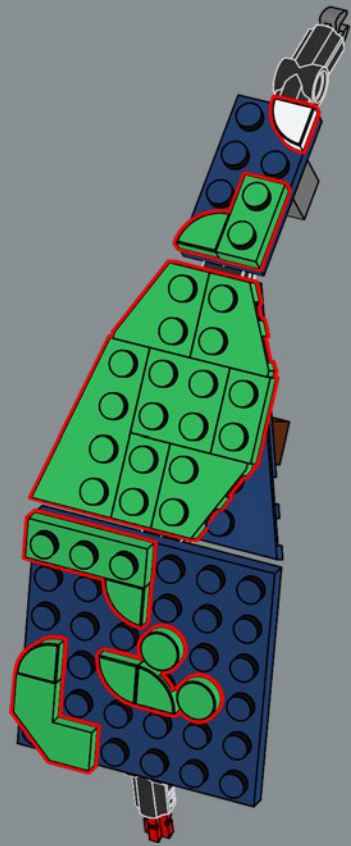
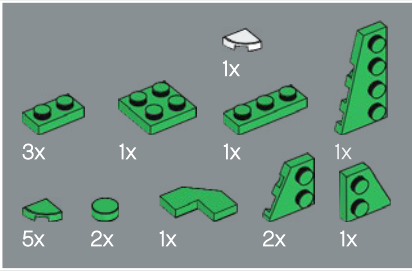

261

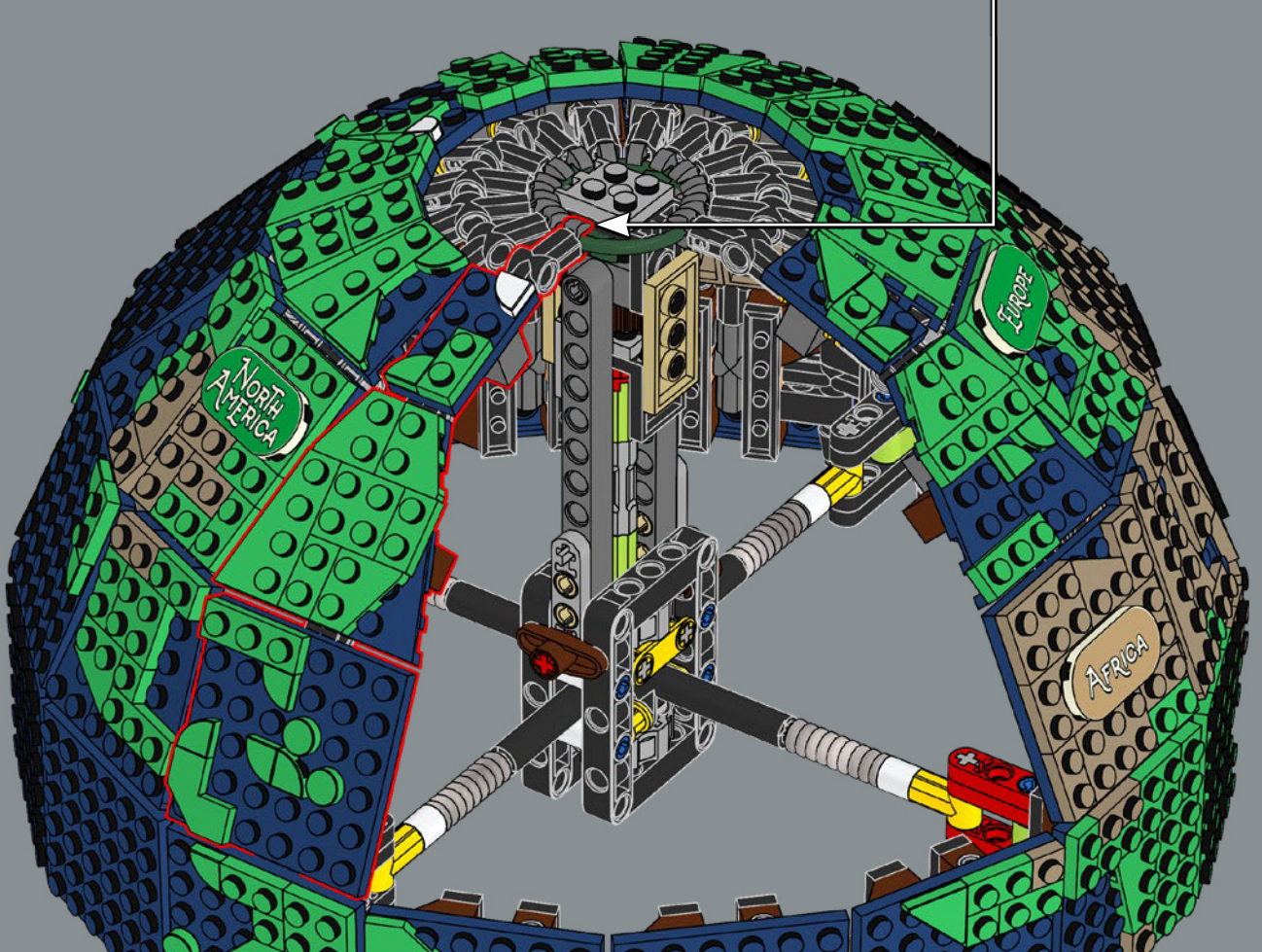

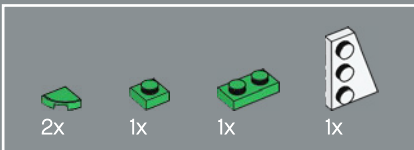

262

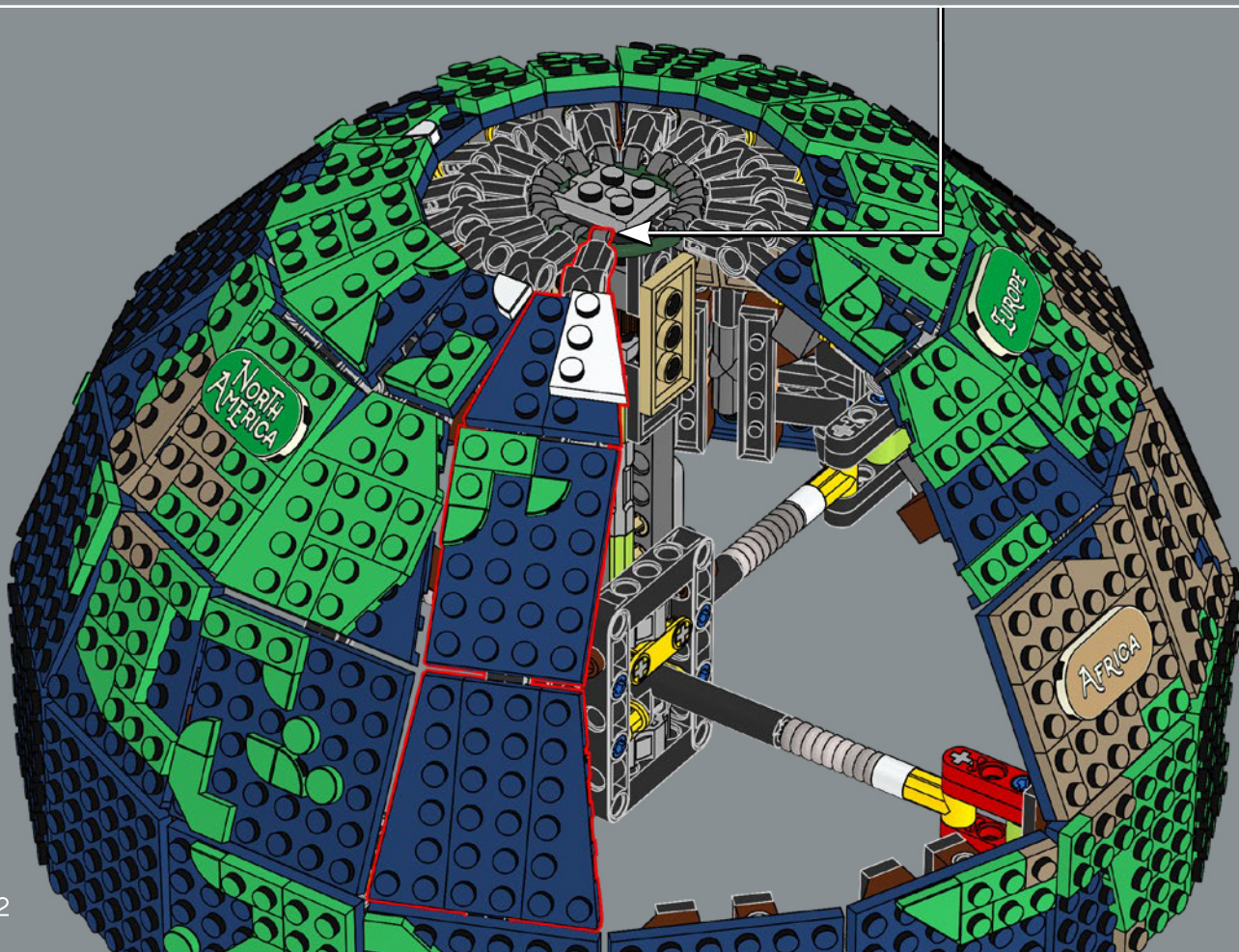
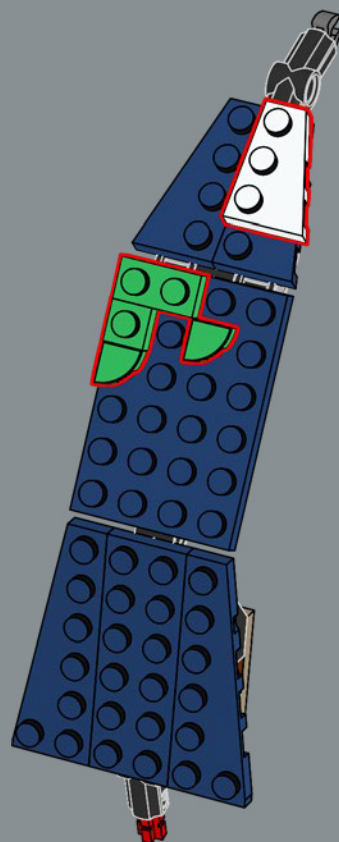



263

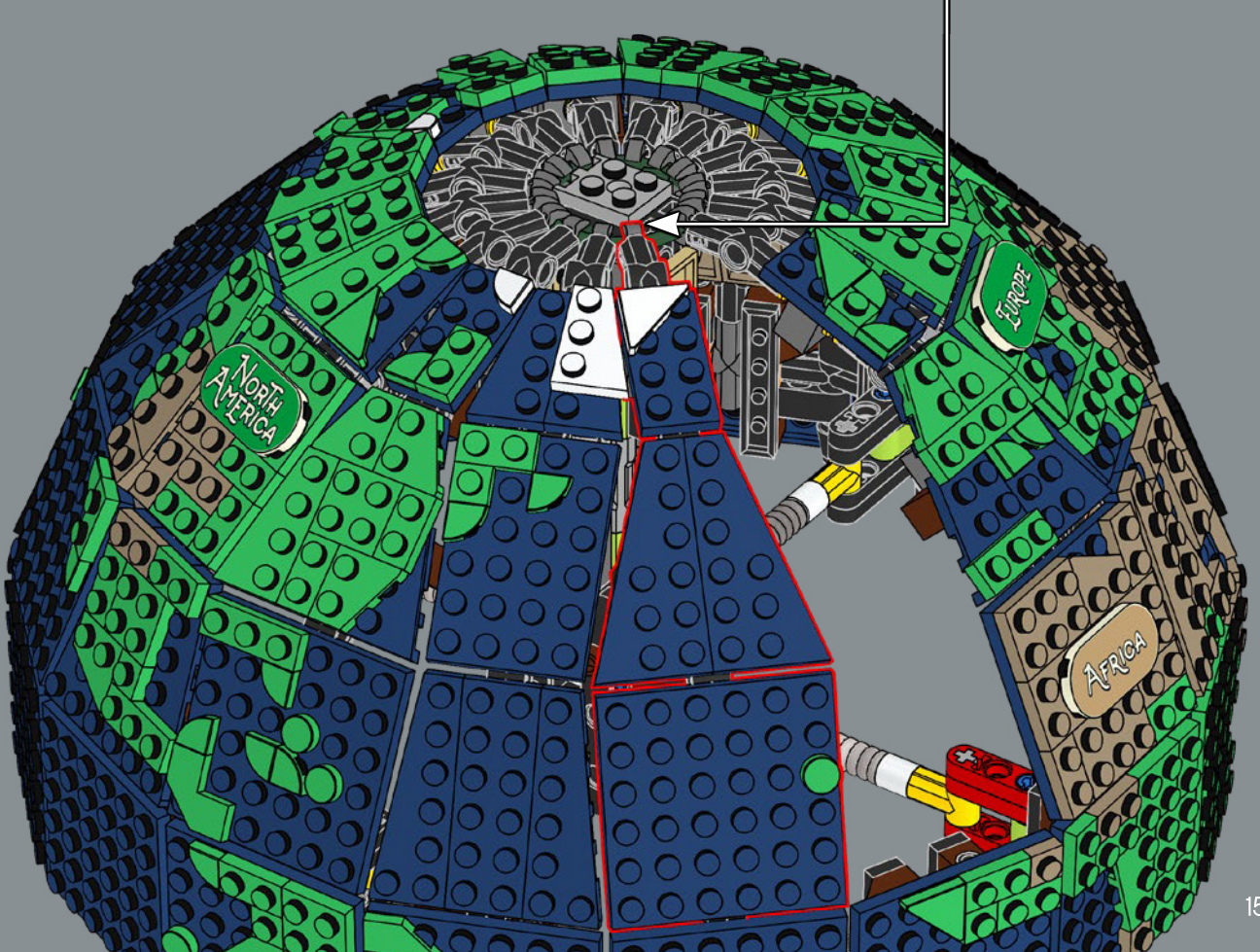
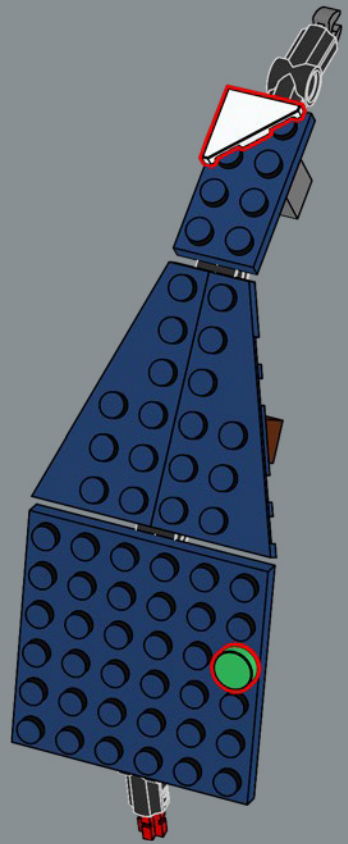

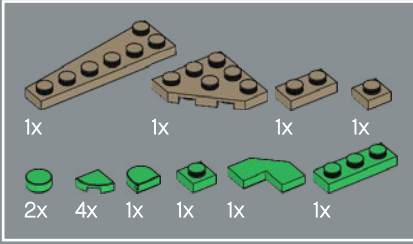
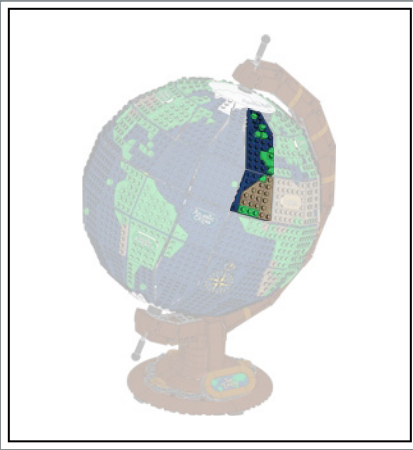

264

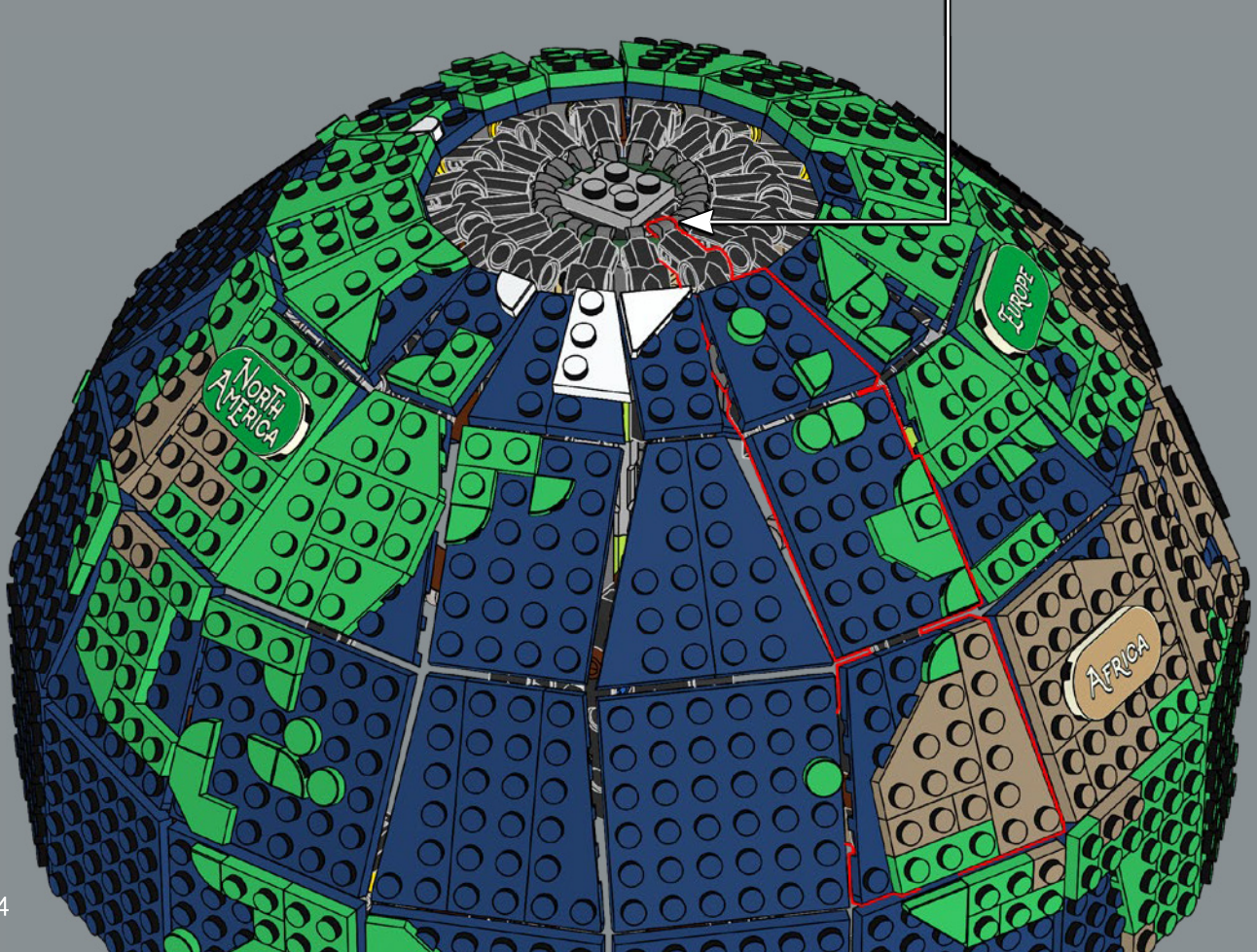
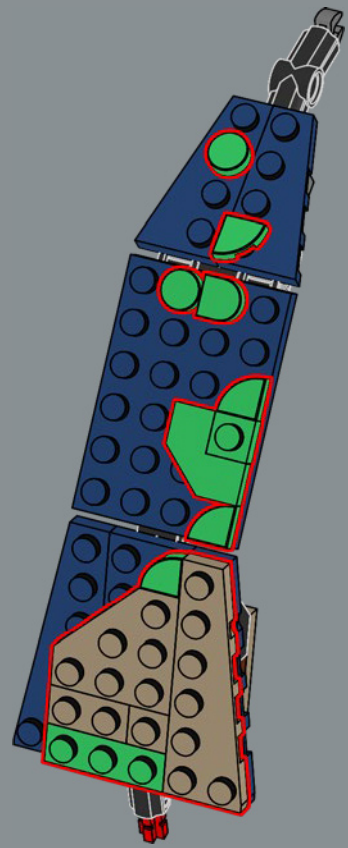

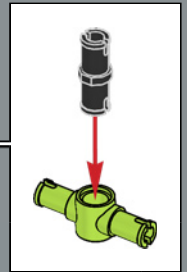
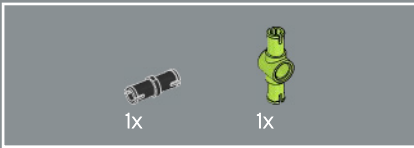

265

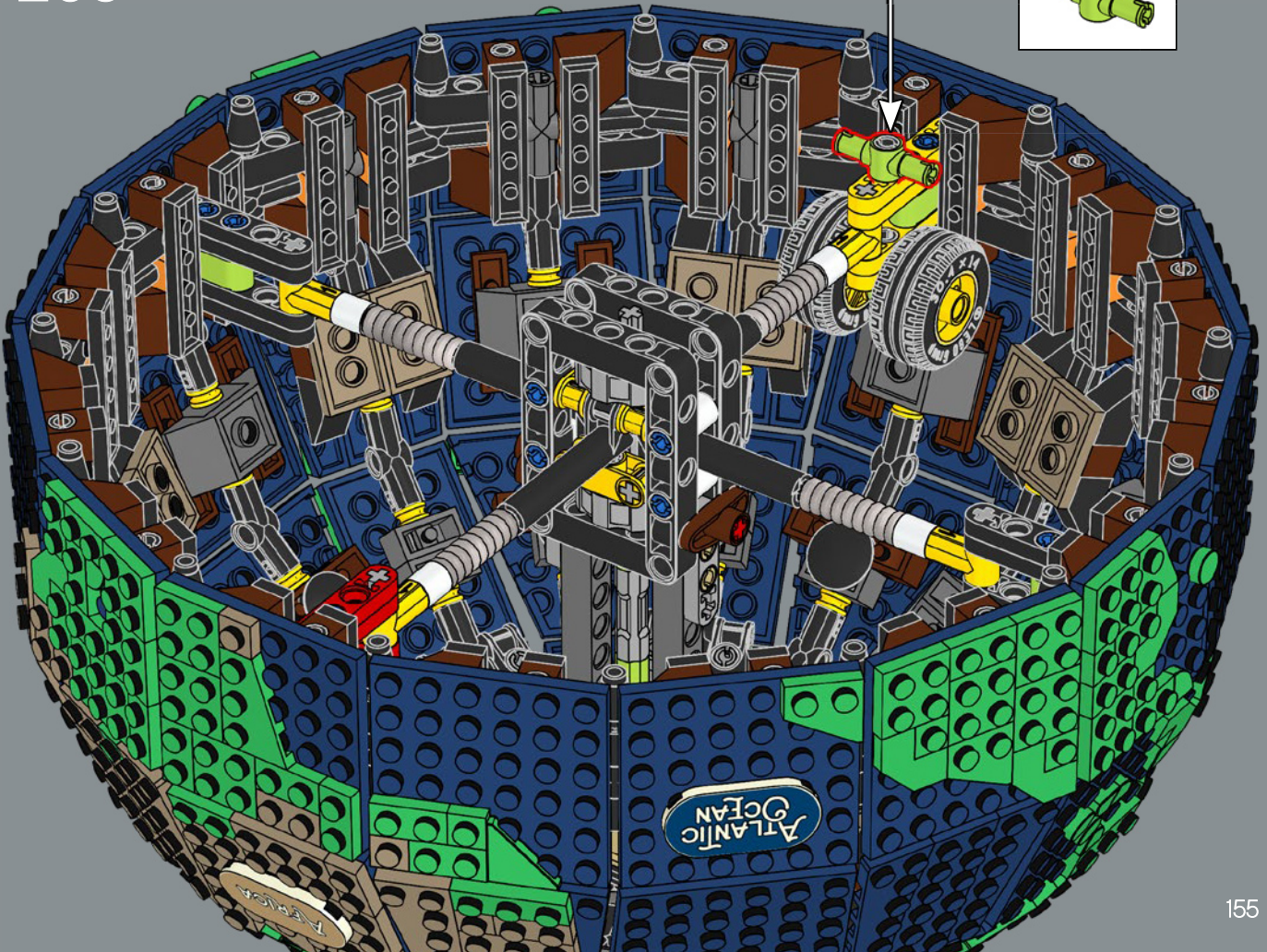



266

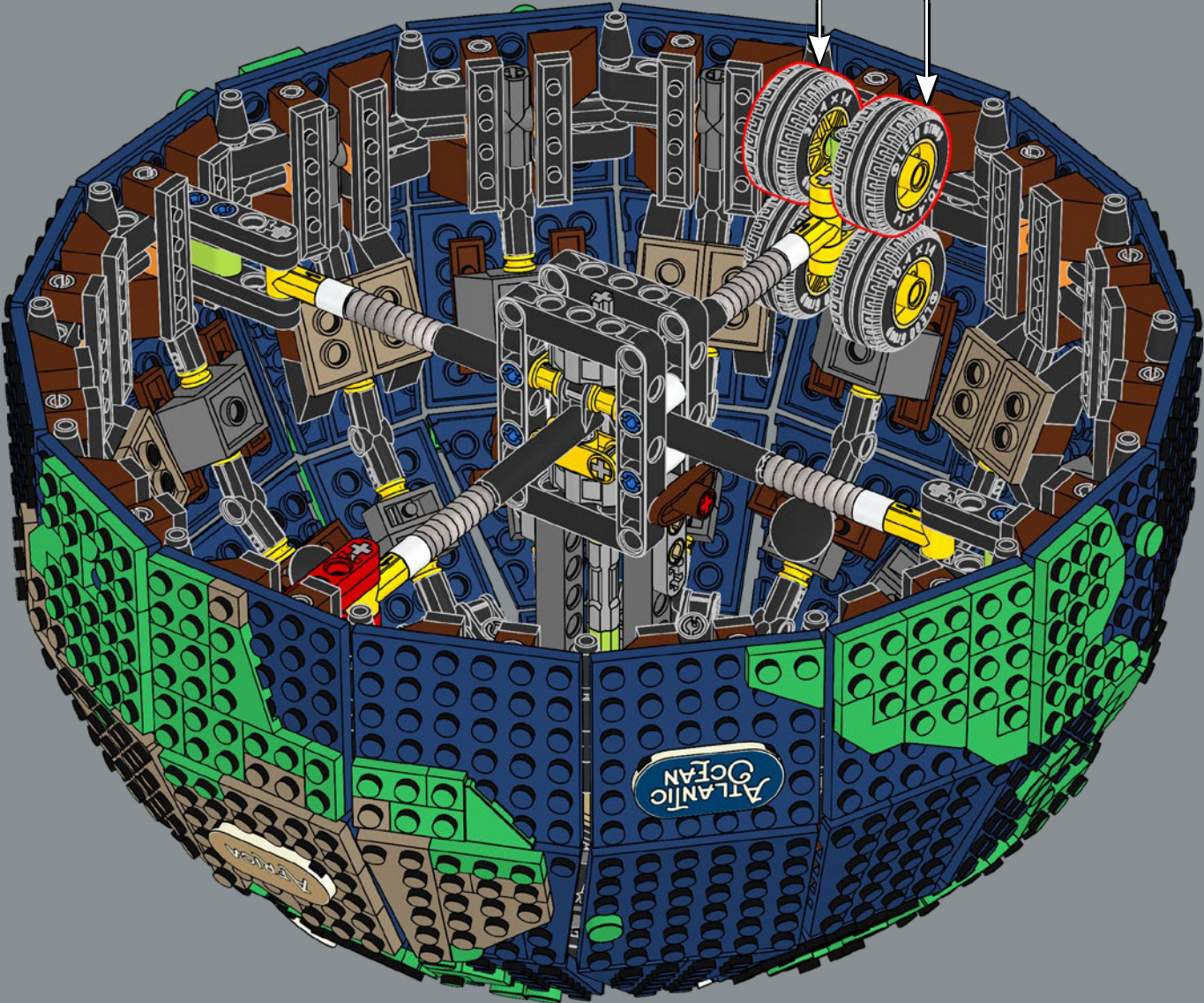
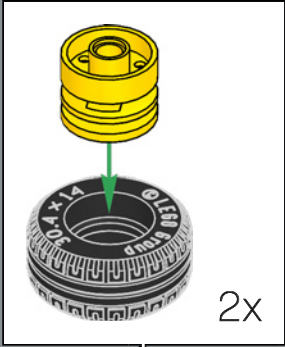

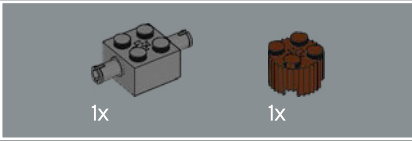
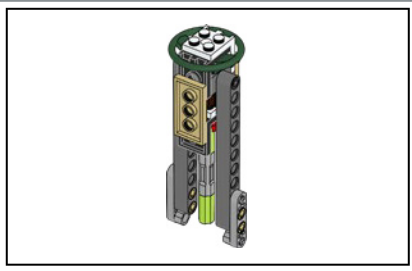

267

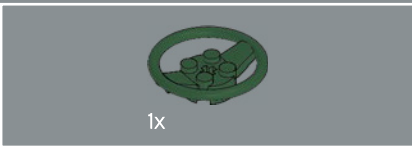
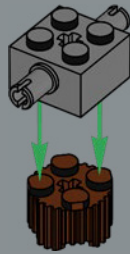

268

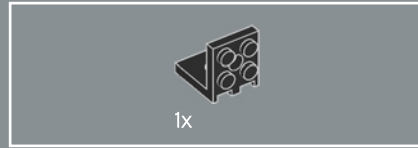
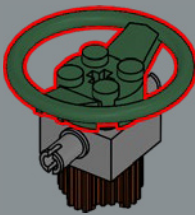

269

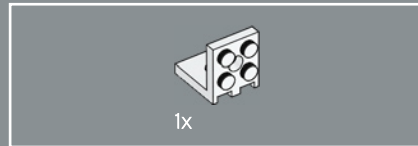
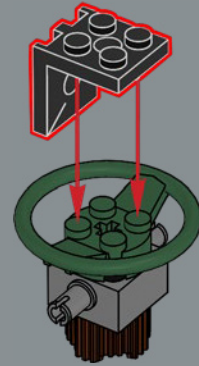

270

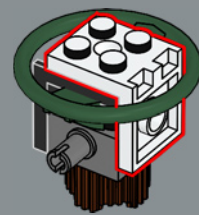

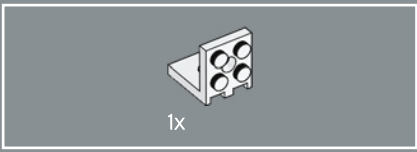

271

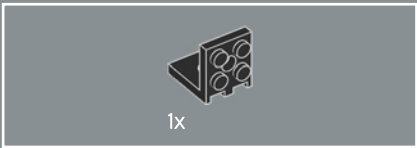
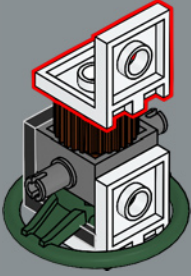

272

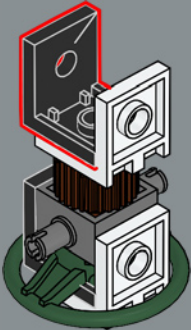

273

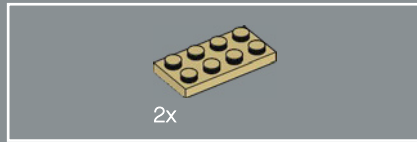
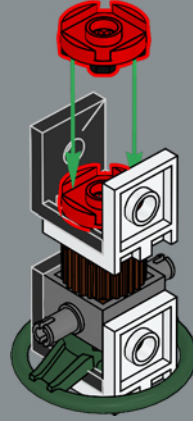

274

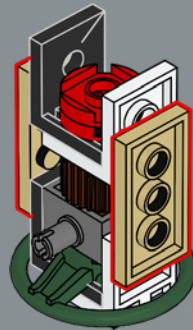

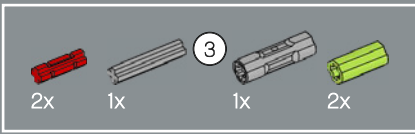

275

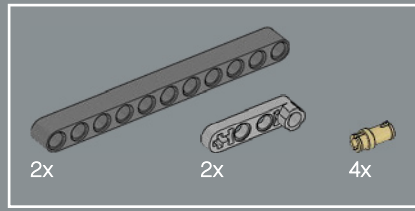
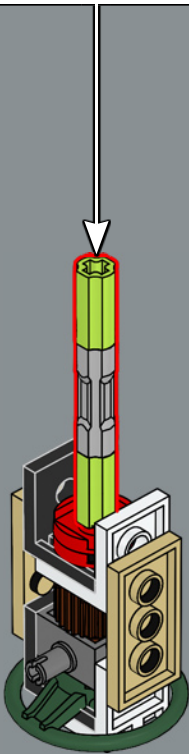
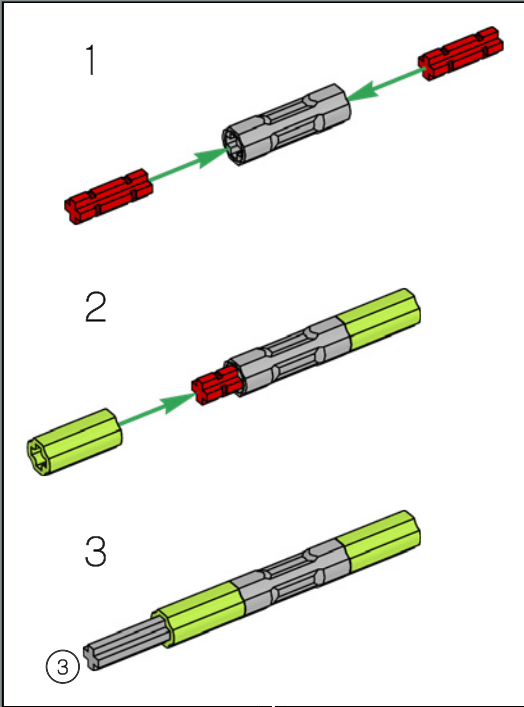

276

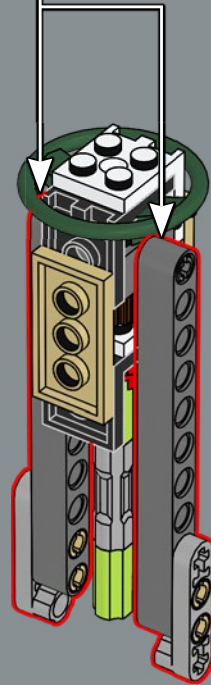
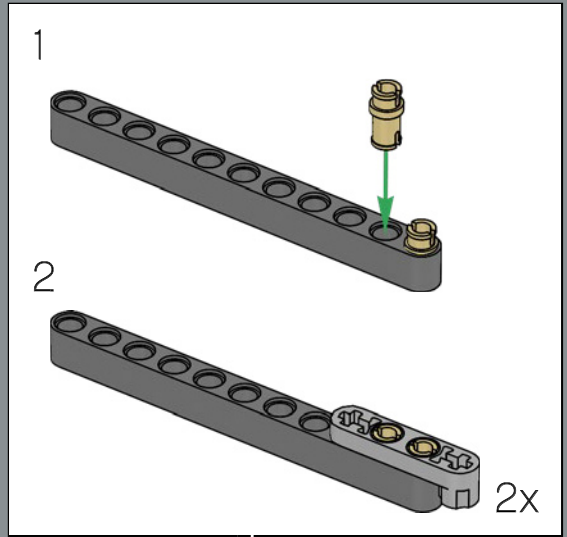

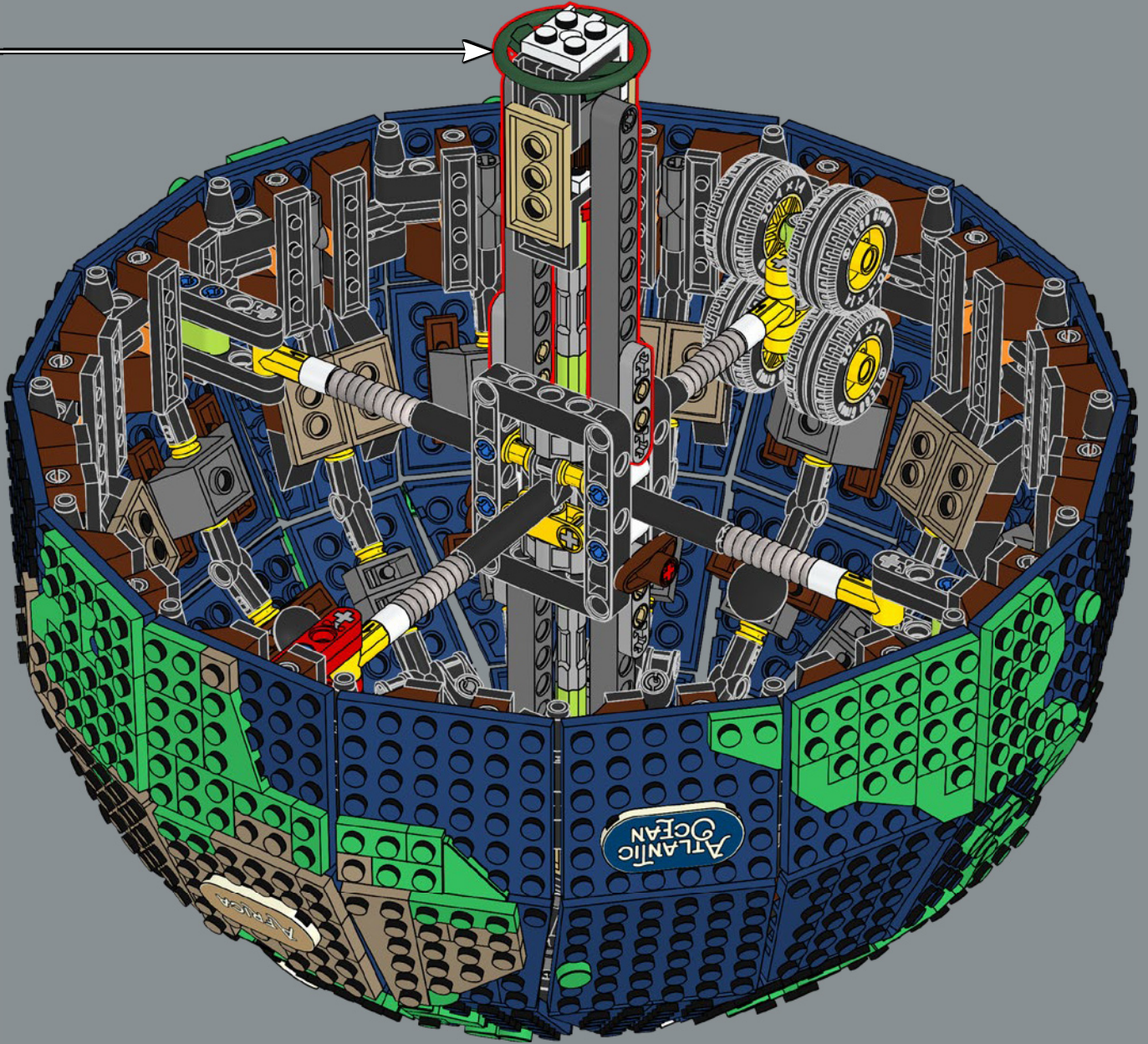

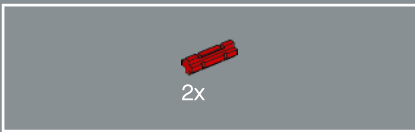

278

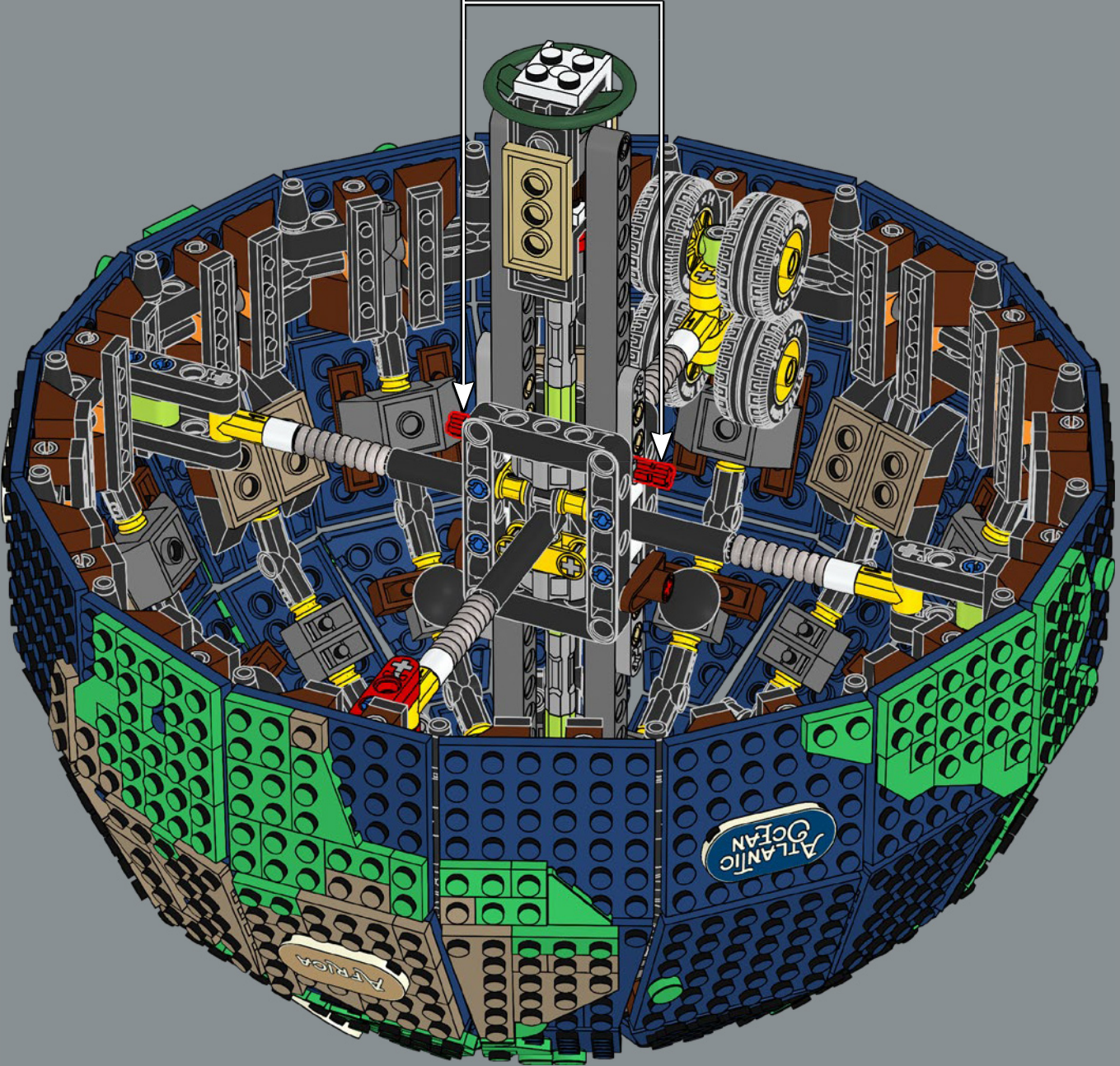



279

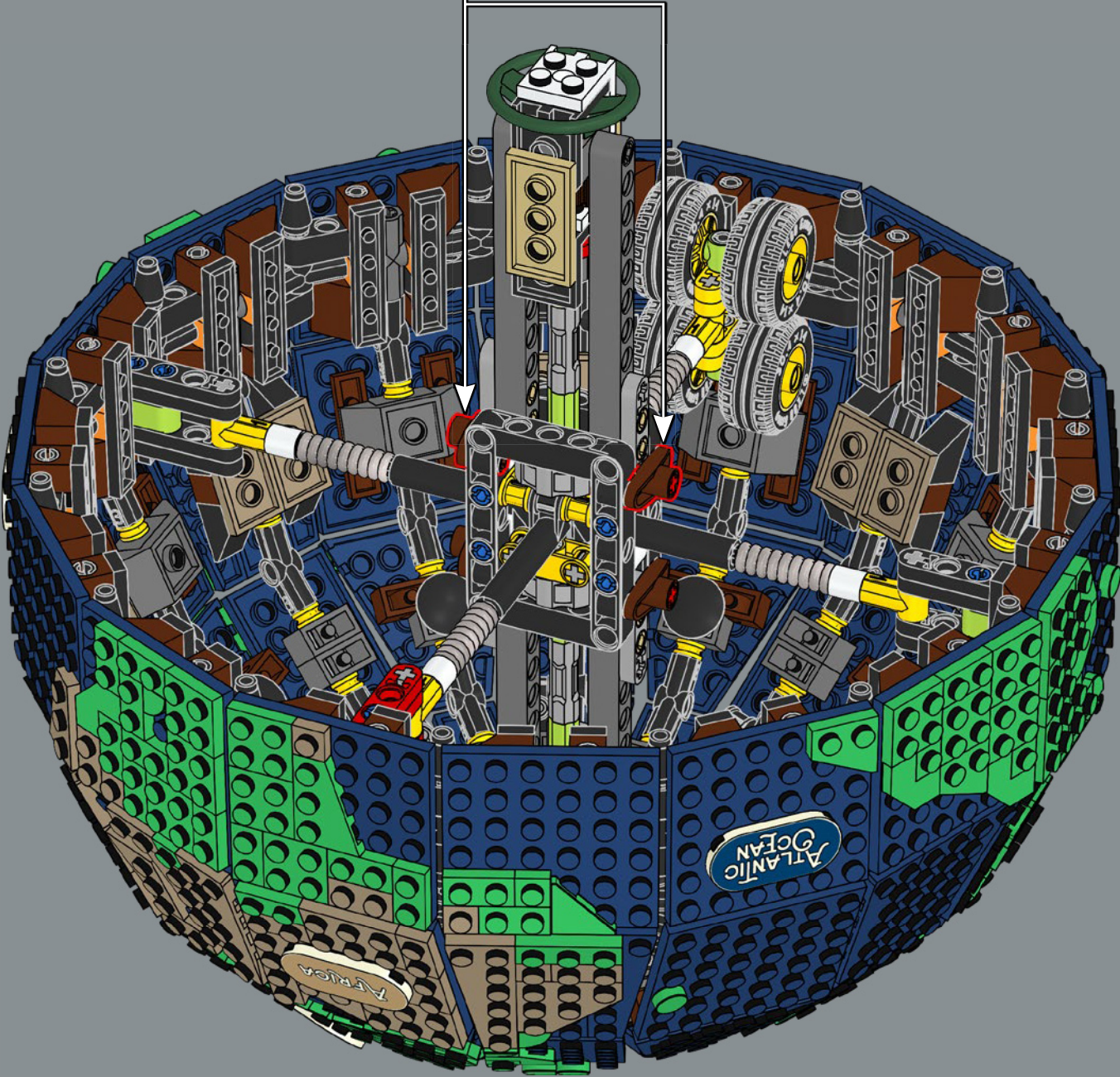

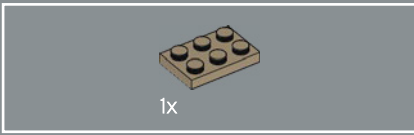
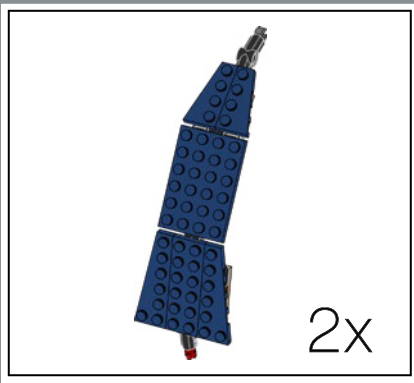

280

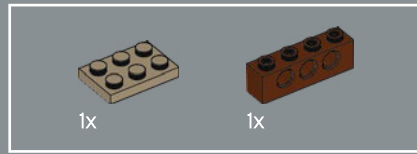

281

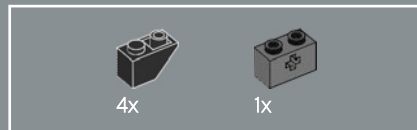
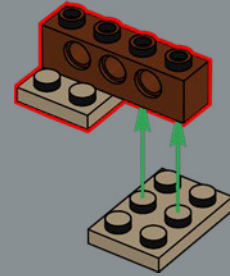

282

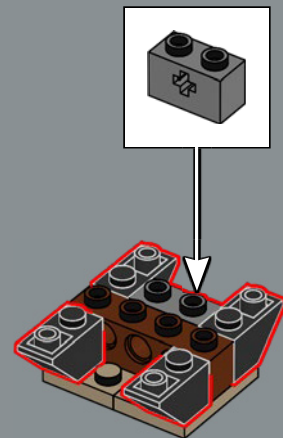

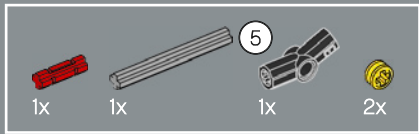

283

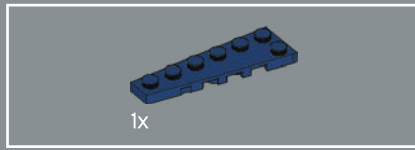
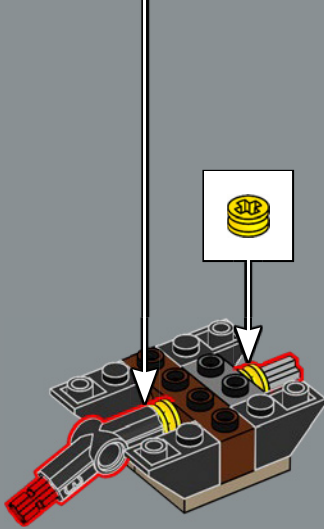
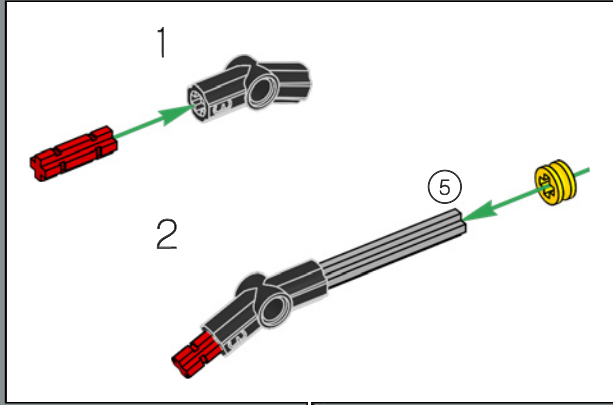

284

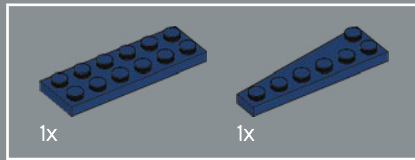
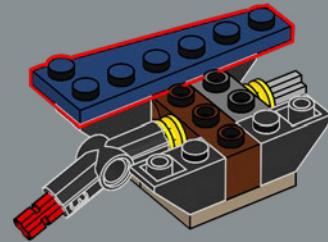

285

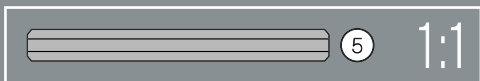
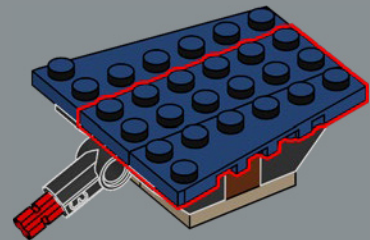

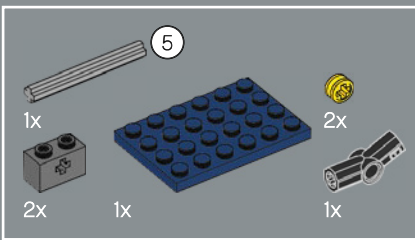

286

1

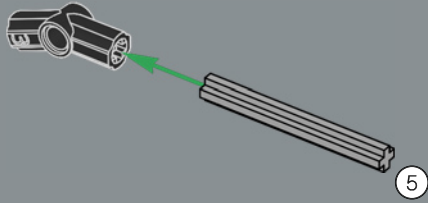

2

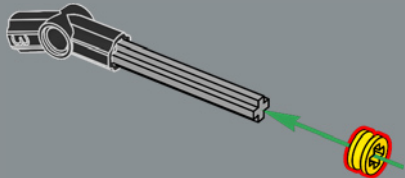

3

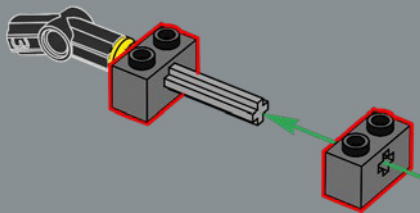

4

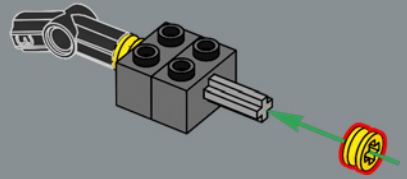

5

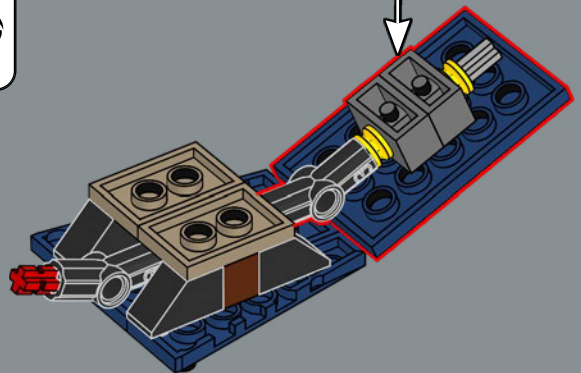
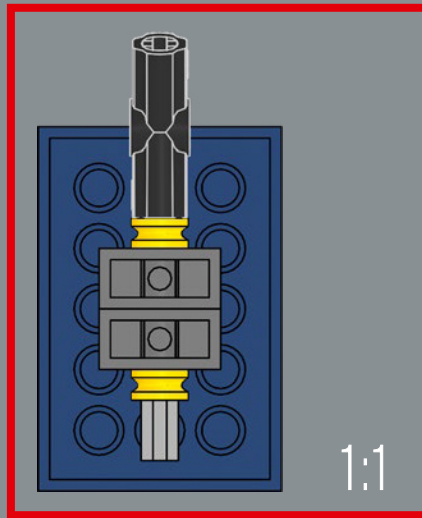
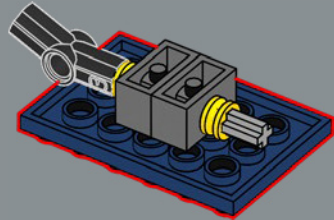

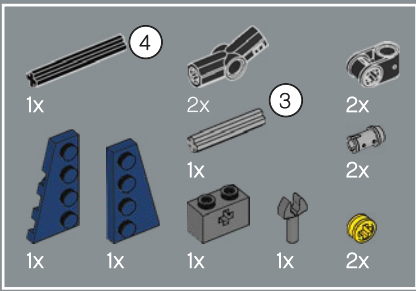

287

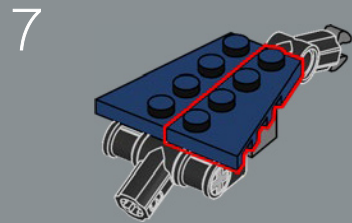
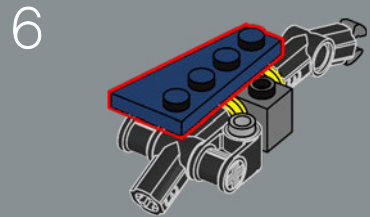
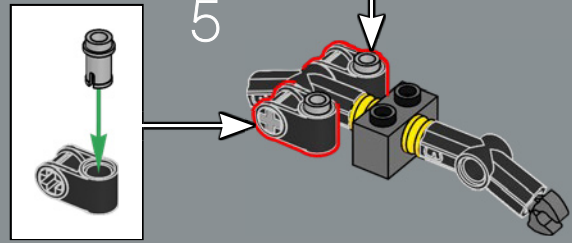
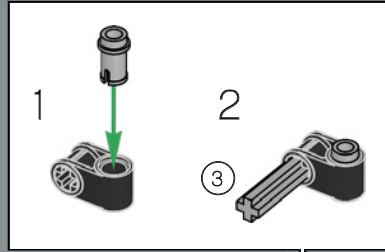
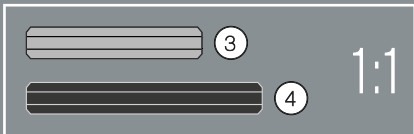
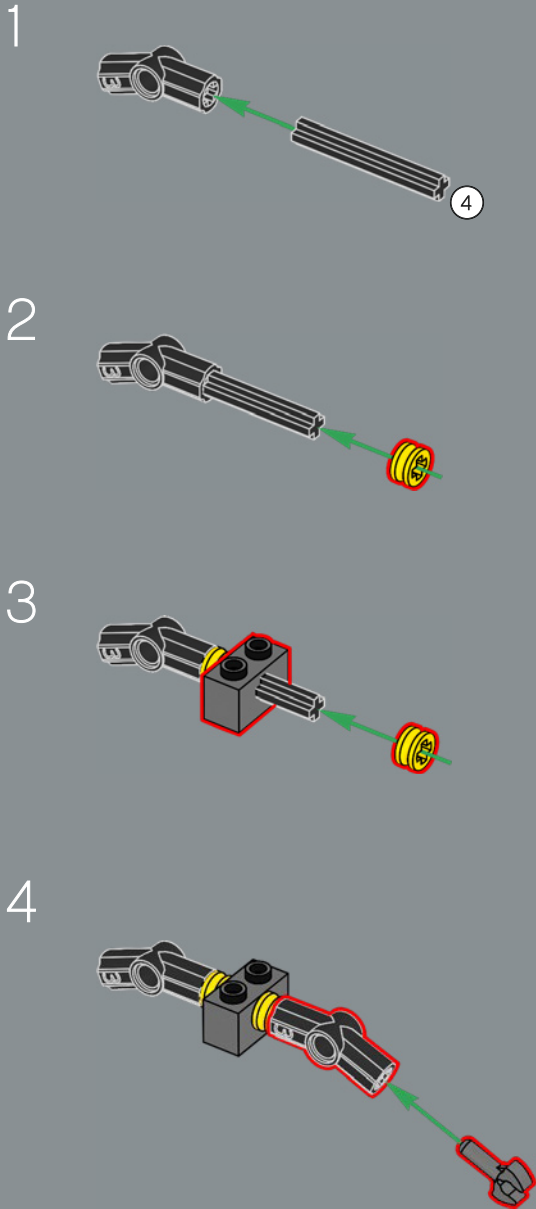

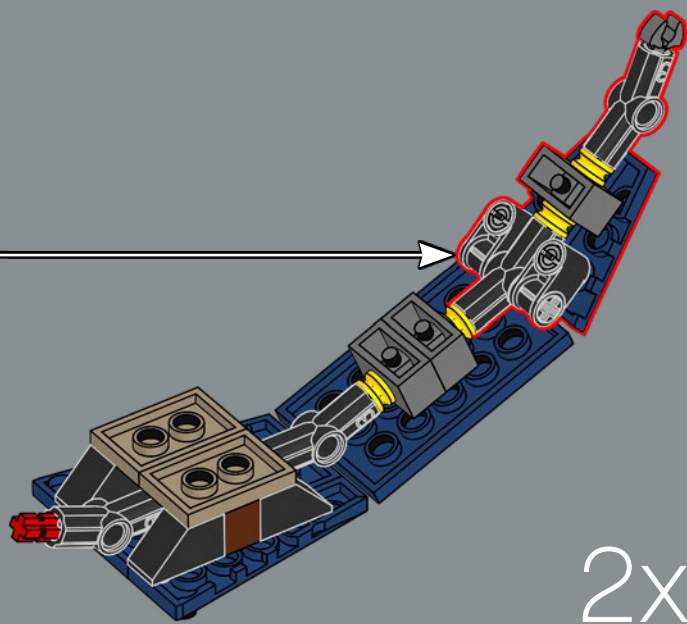

2x

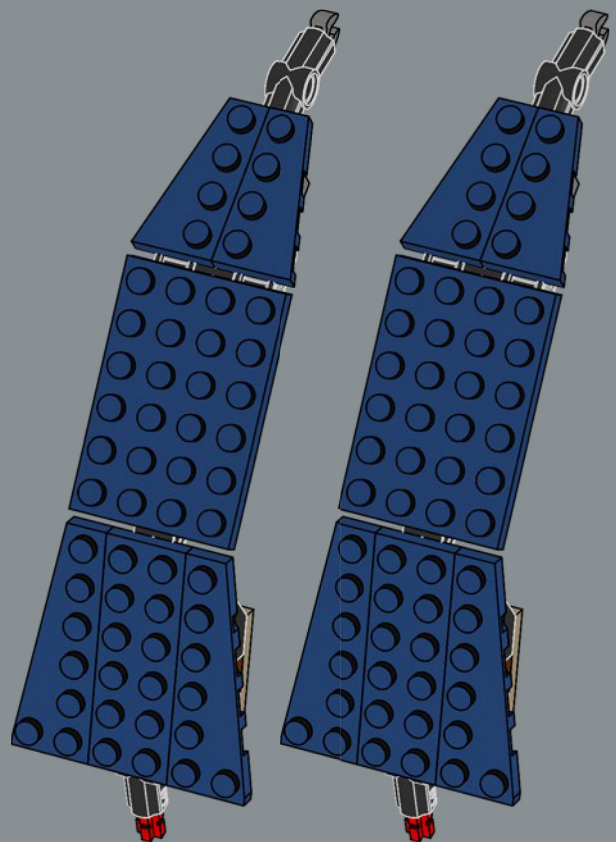

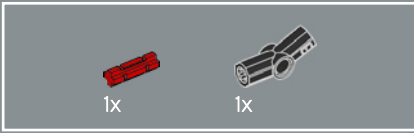
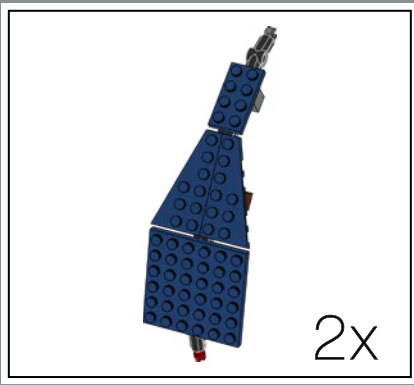

288

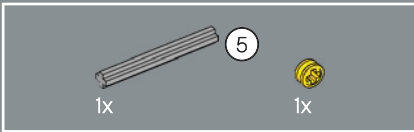
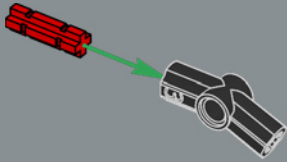

289

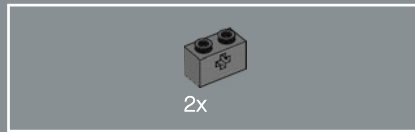
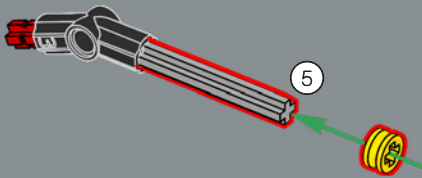

290

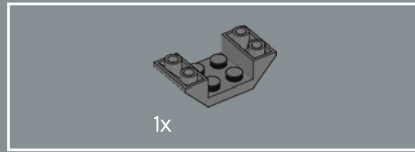
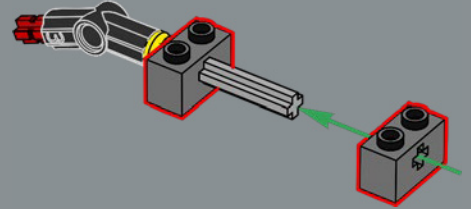

291

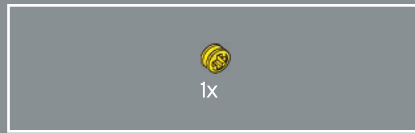
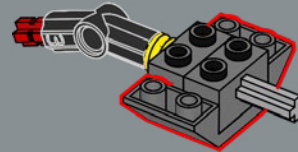

292

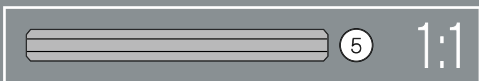
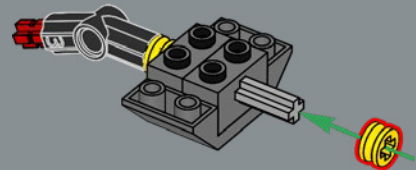



293

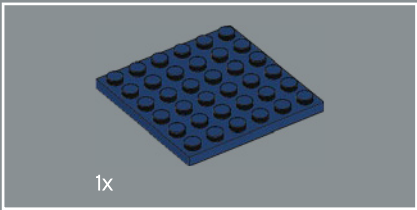
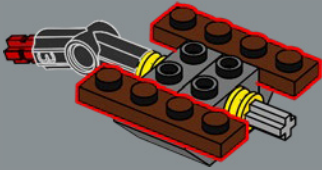

294

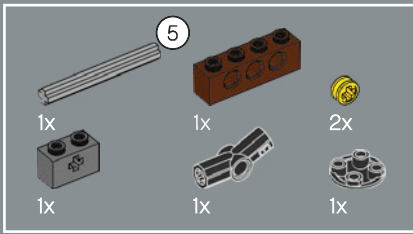
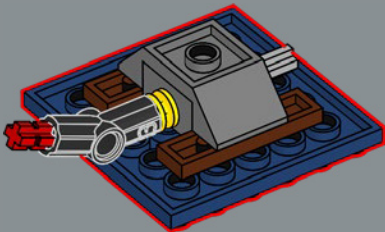

295

1

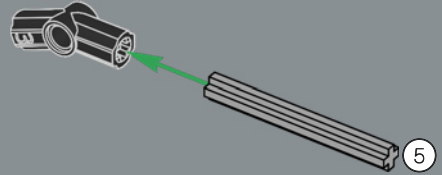

2

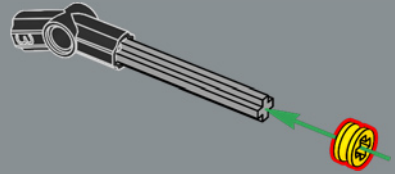

3

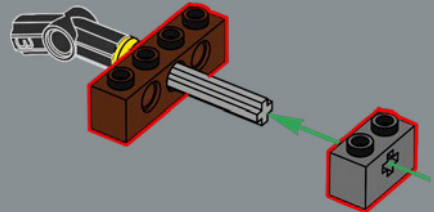

4

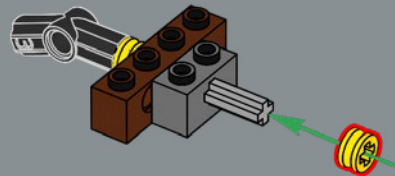

5

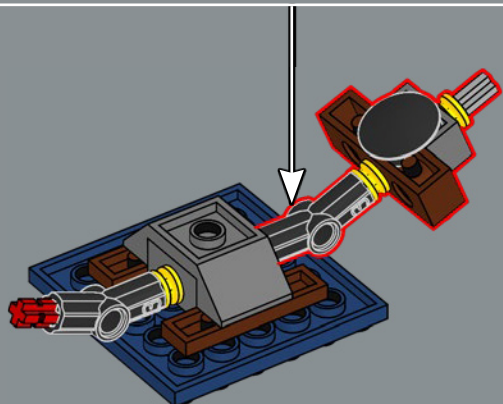
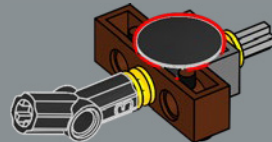

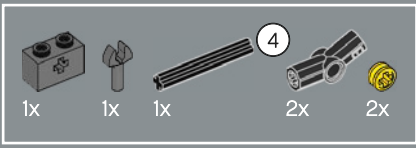

296

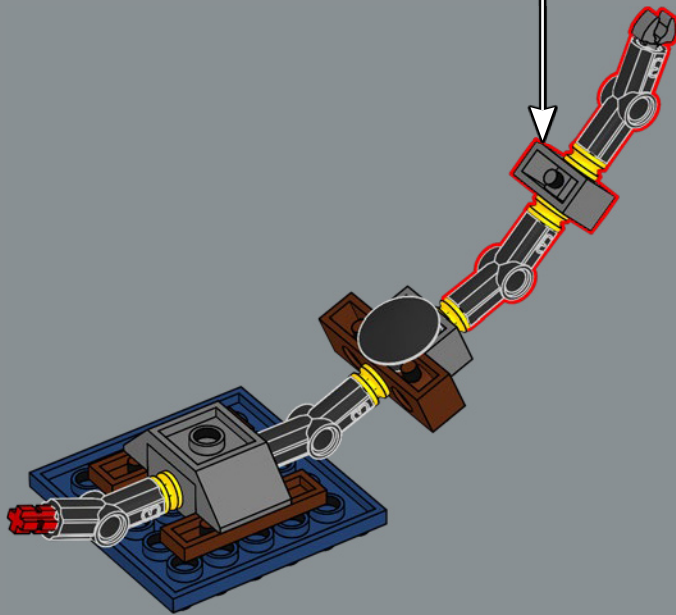
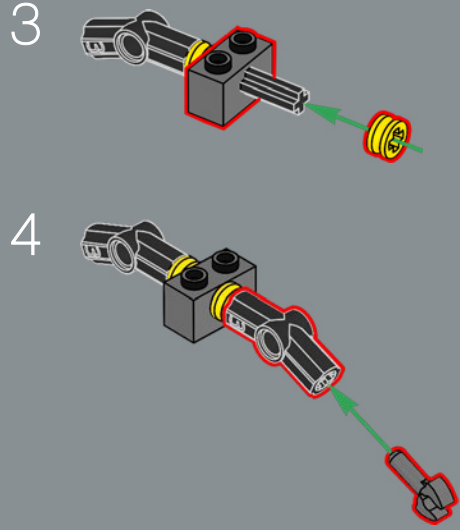
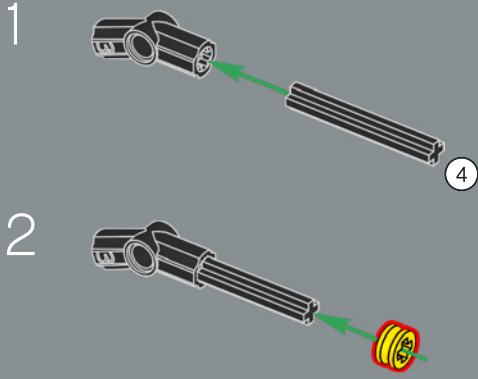

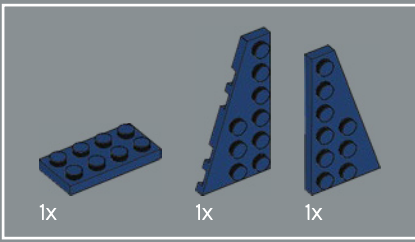

297

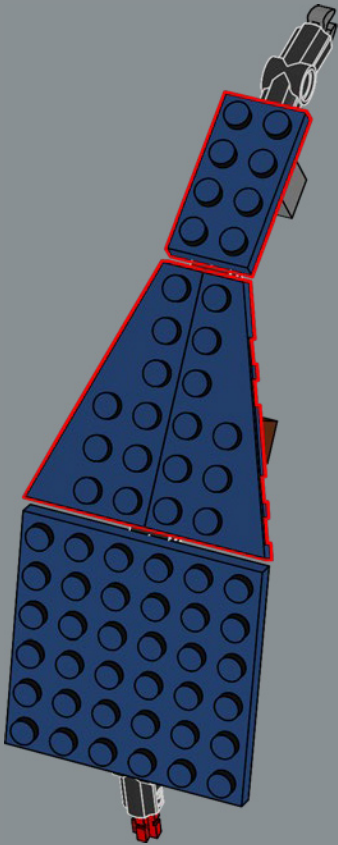

2x

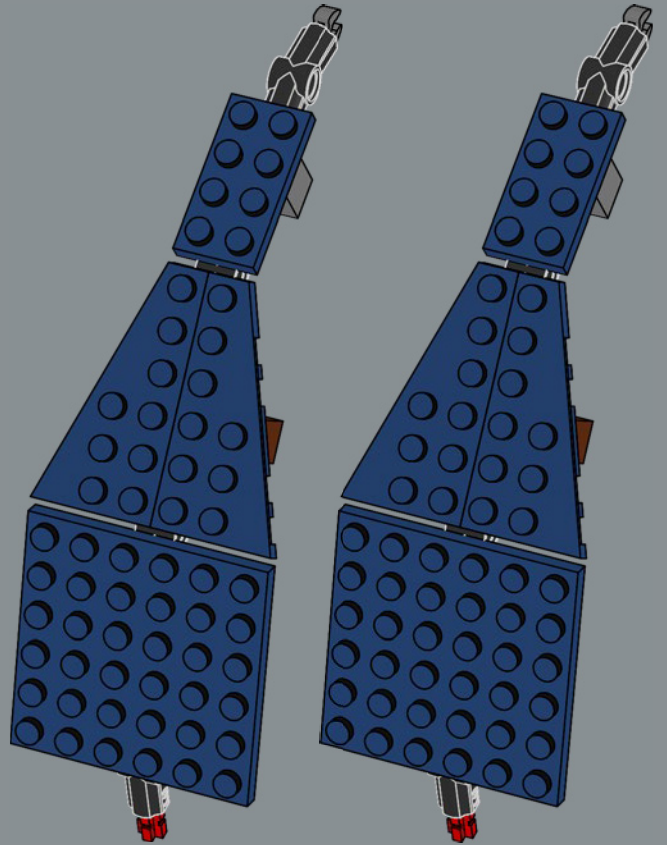

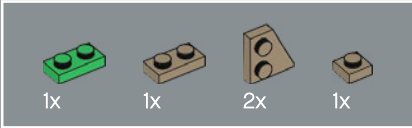

298

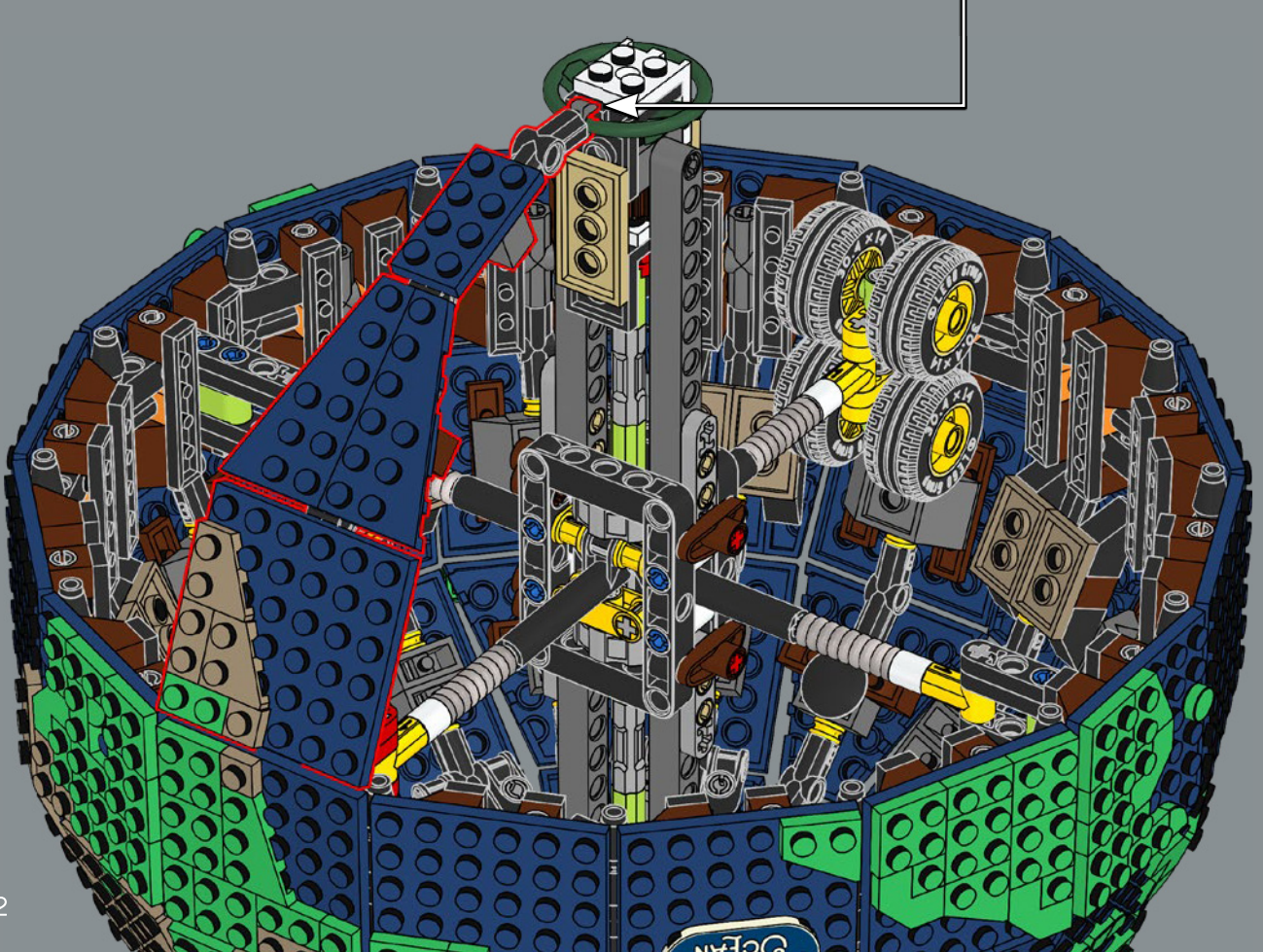
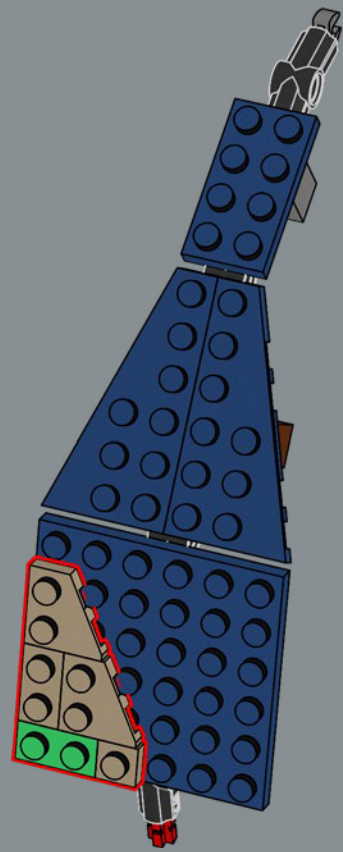

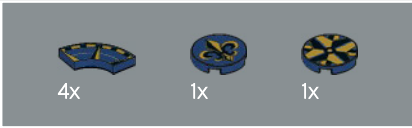

299

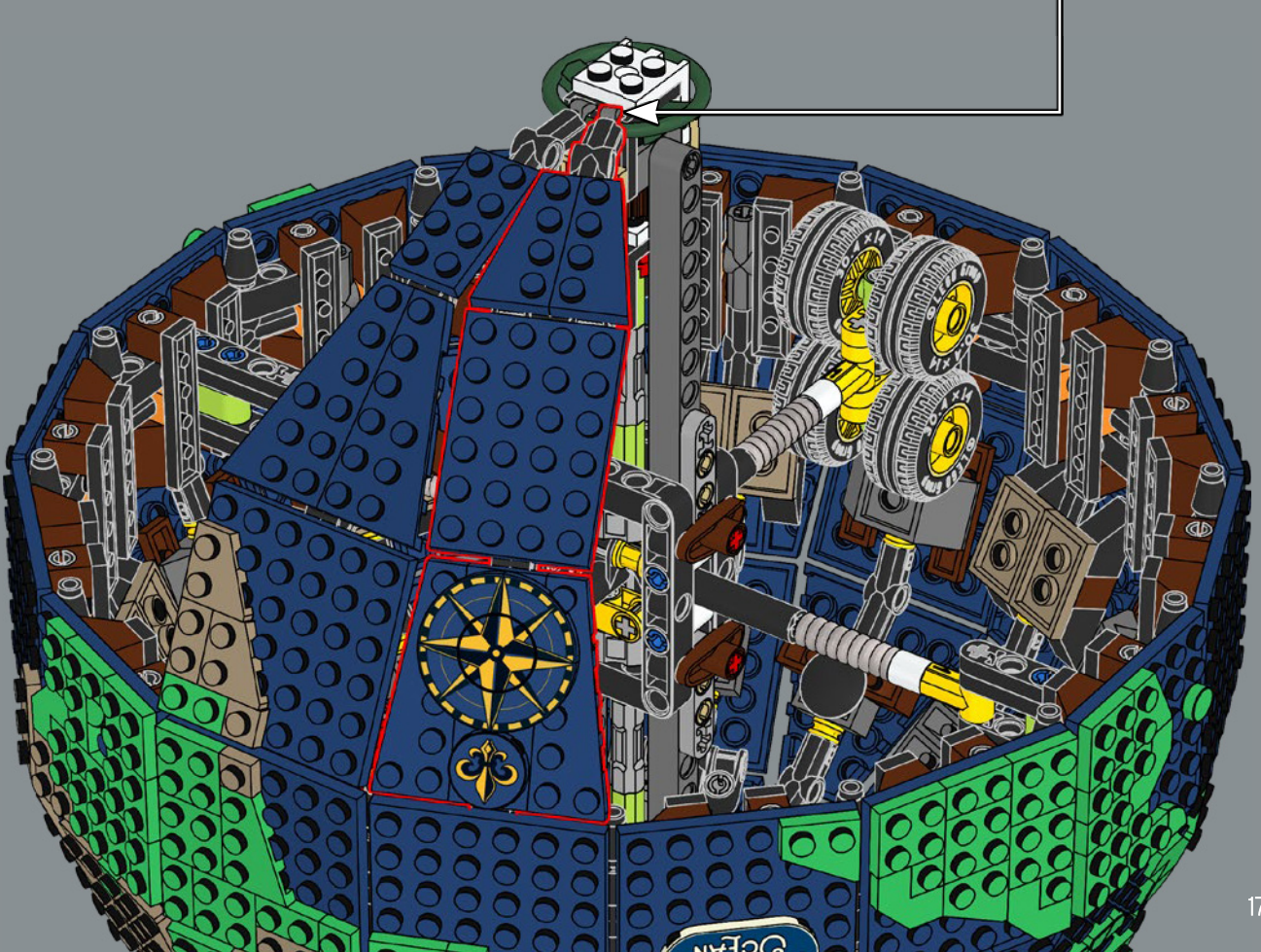
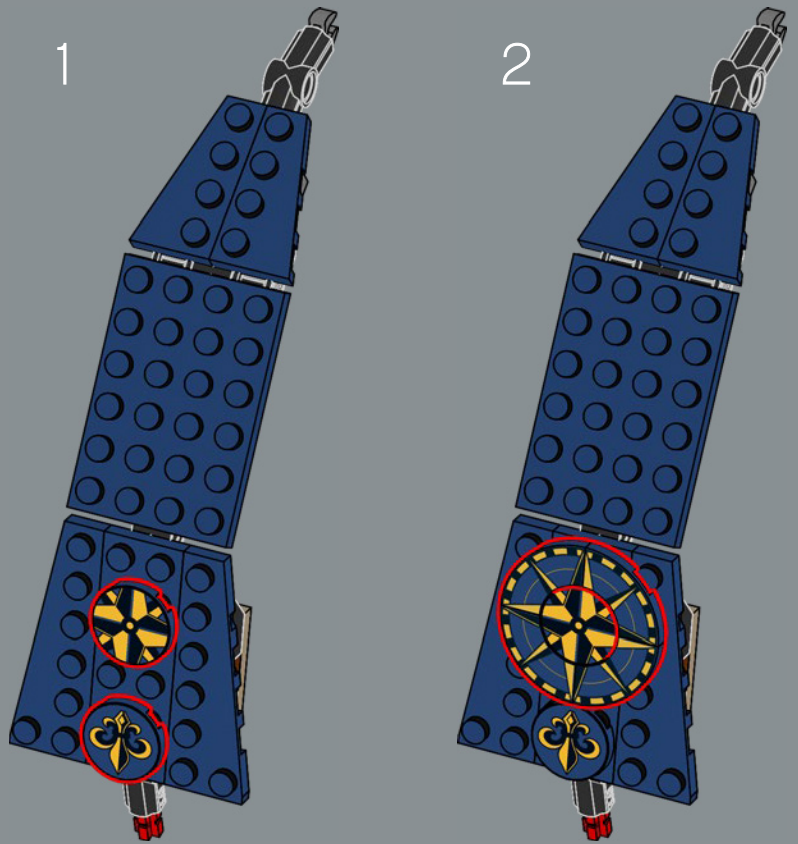

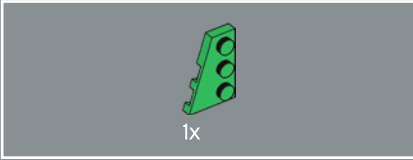

300

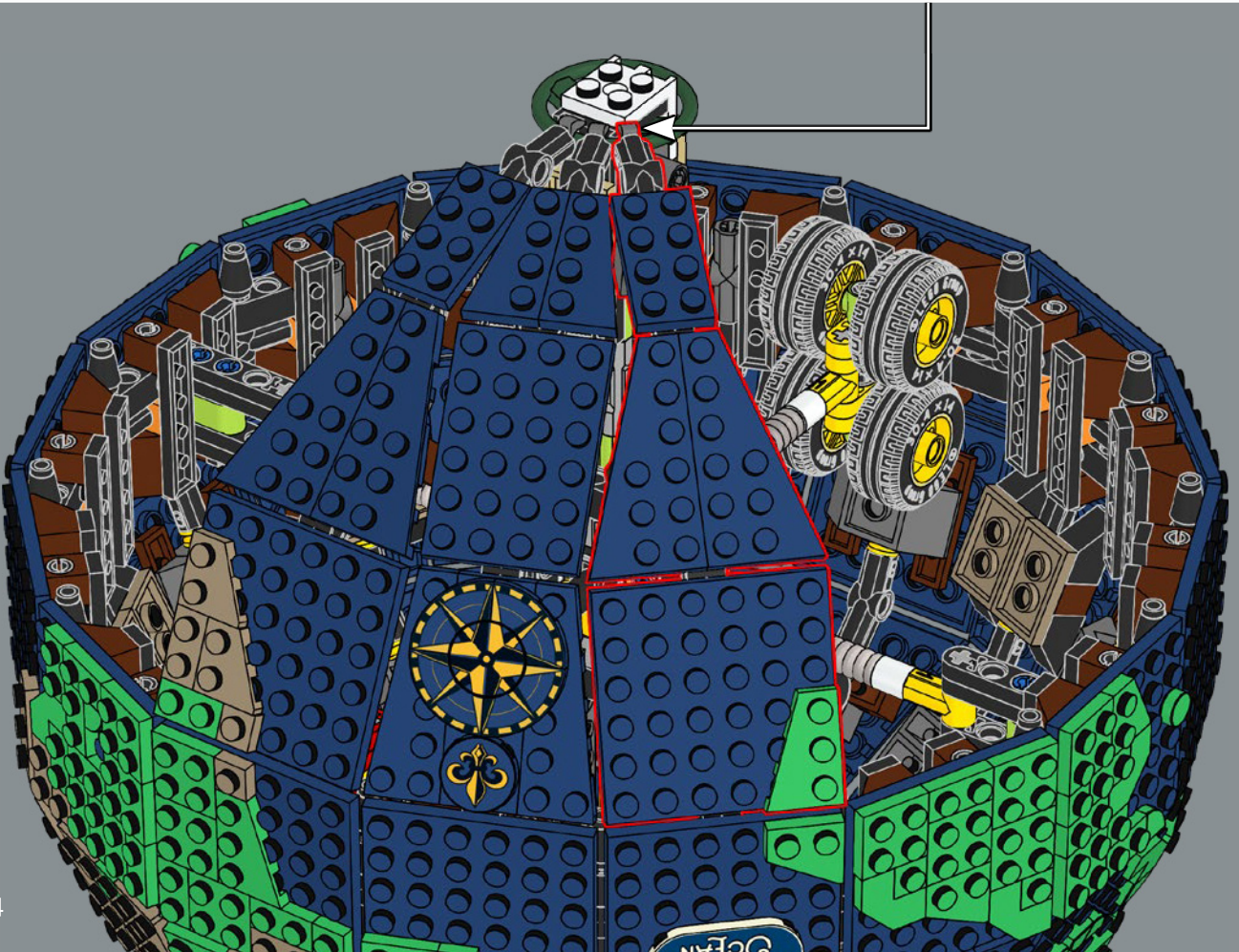
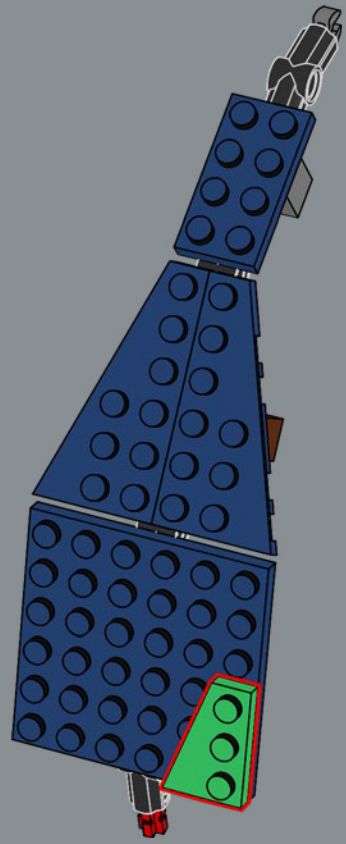

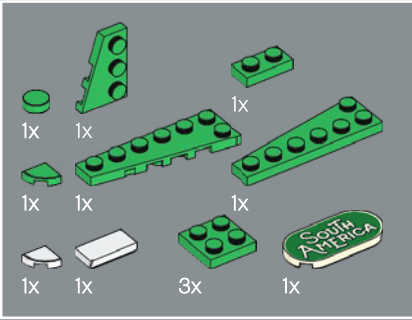

301

1

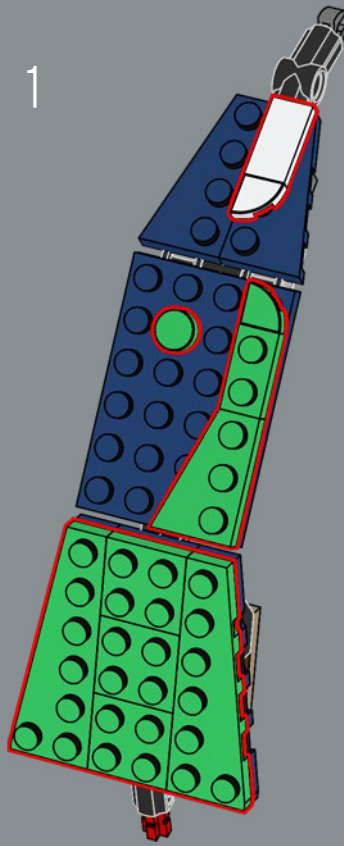

2

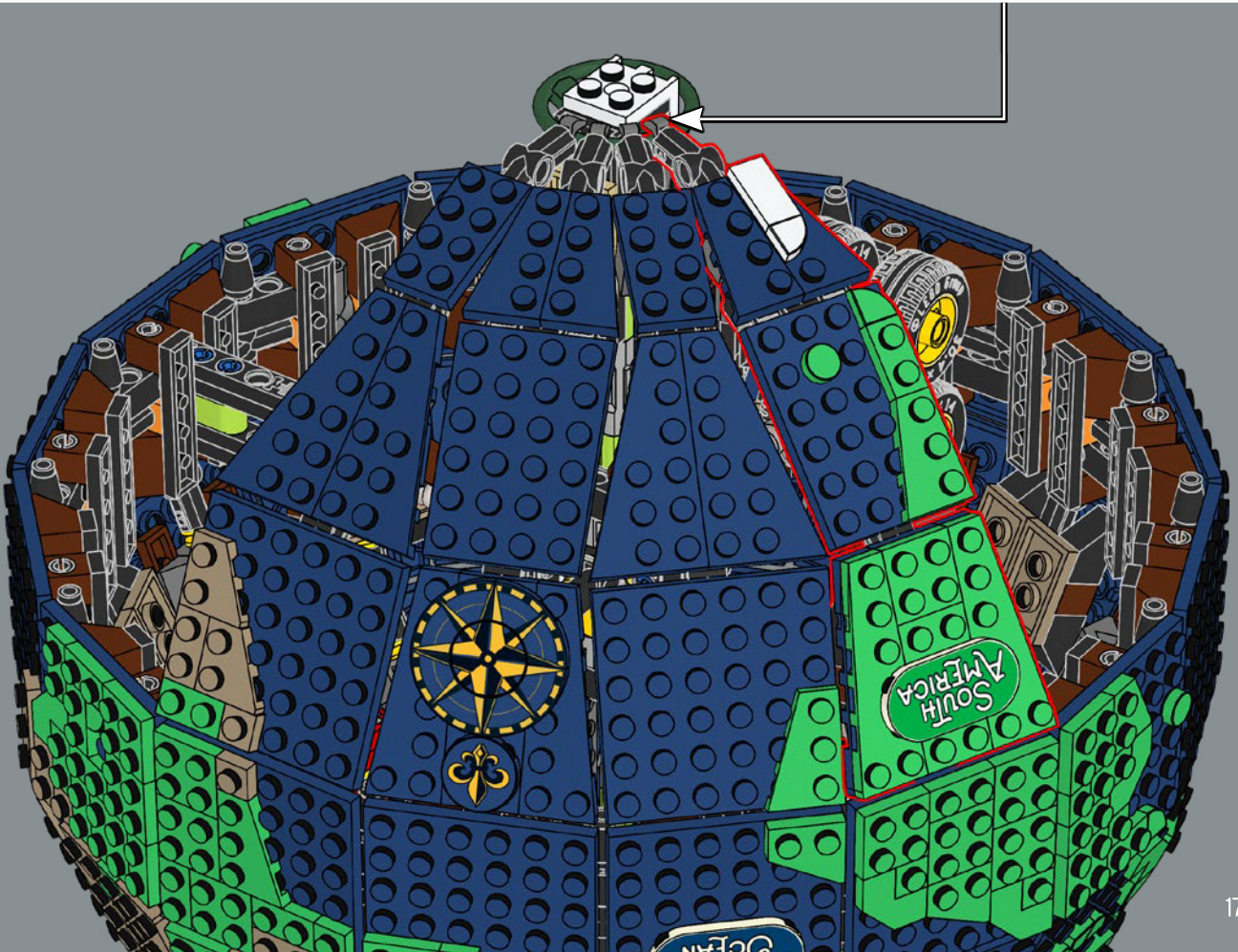
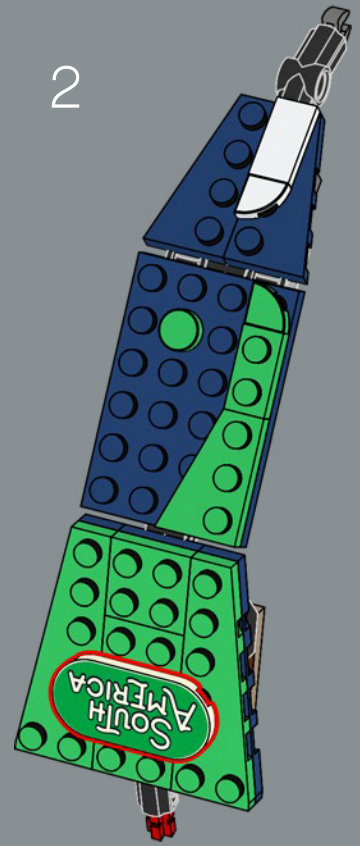

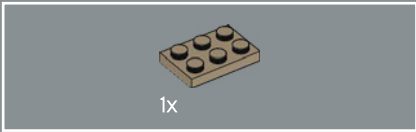
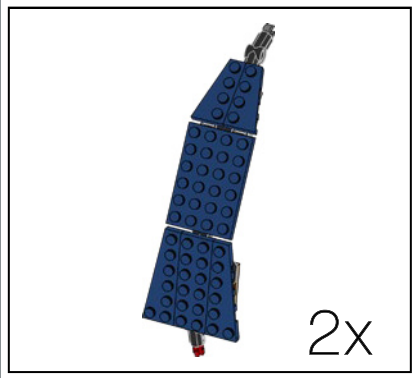
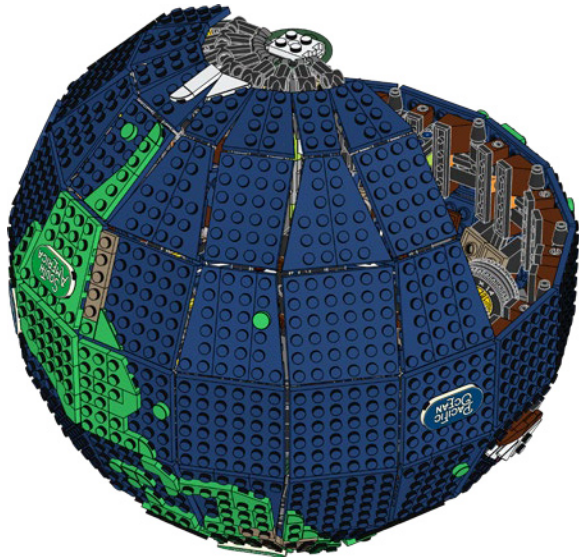

302

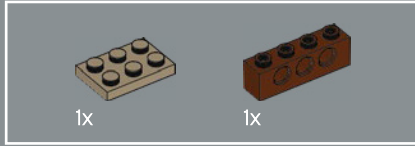

303

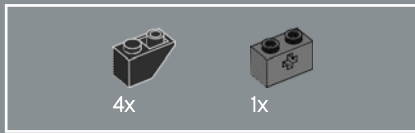
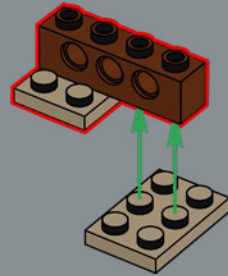

304

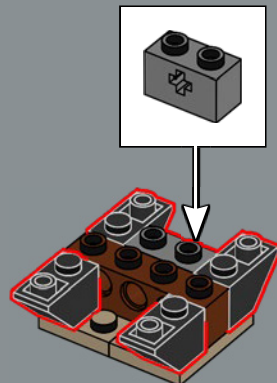

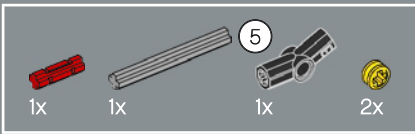

305

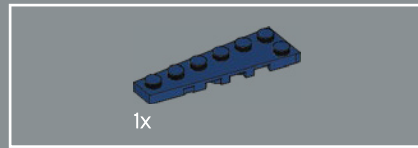
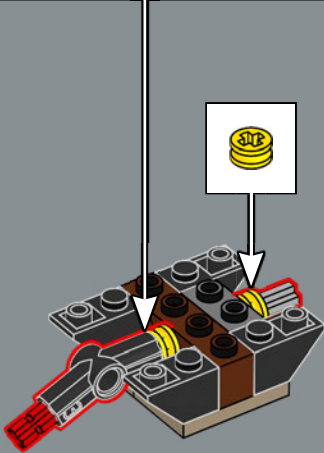
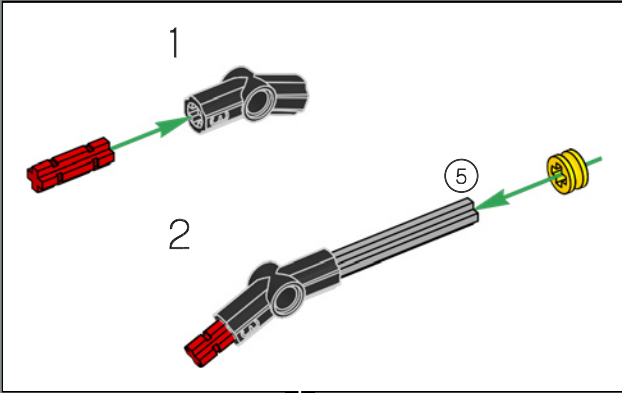

306

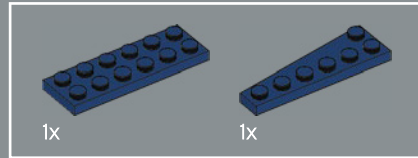
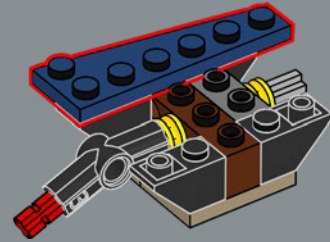

307

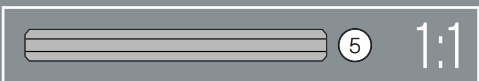
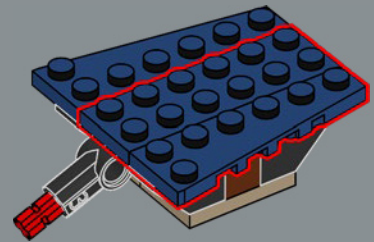

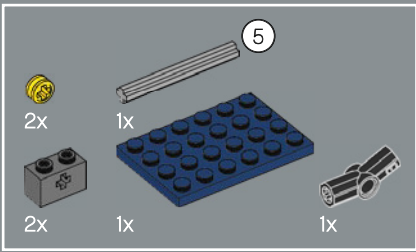

308

1

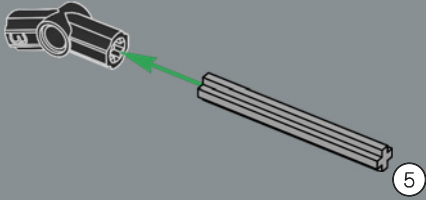

2

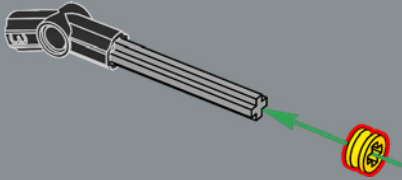

3

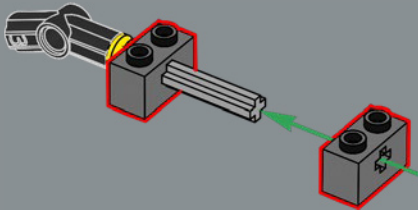

4

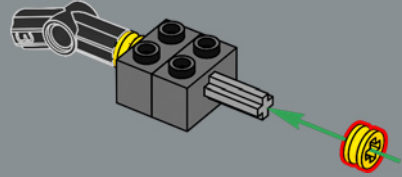

5

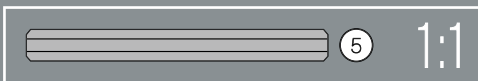
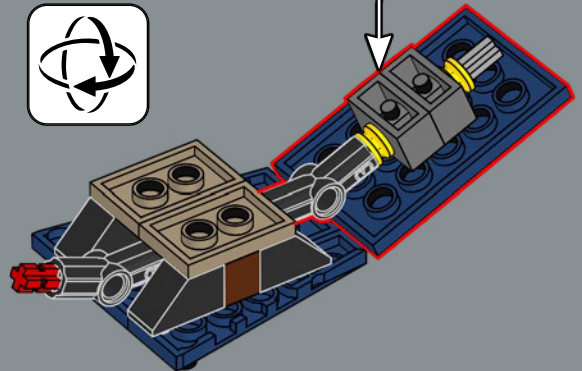
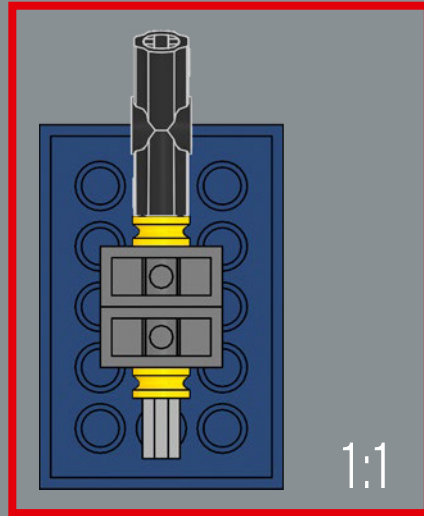
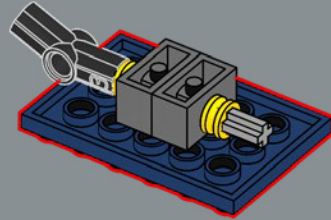

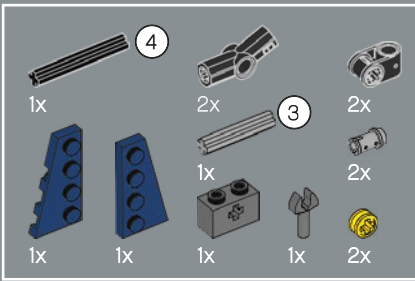

309

1

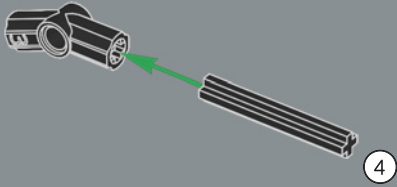

2

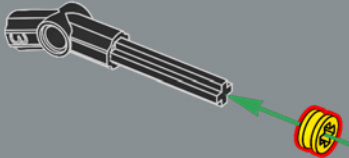

3

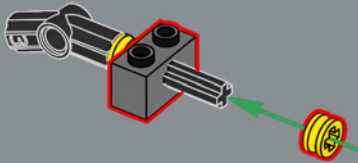

4

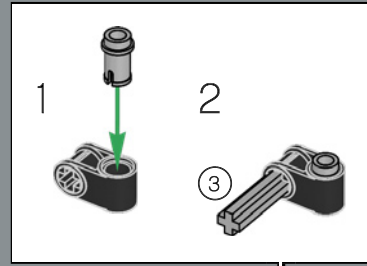
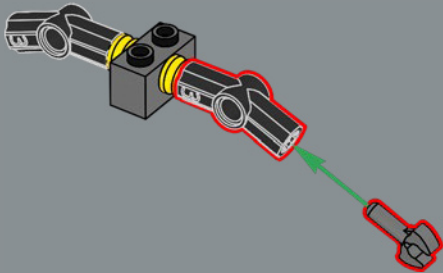

5

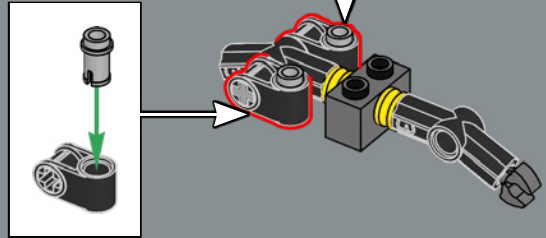

6

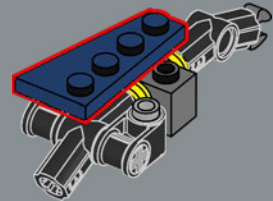

7

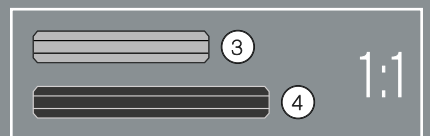
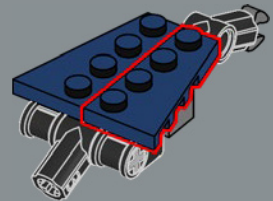

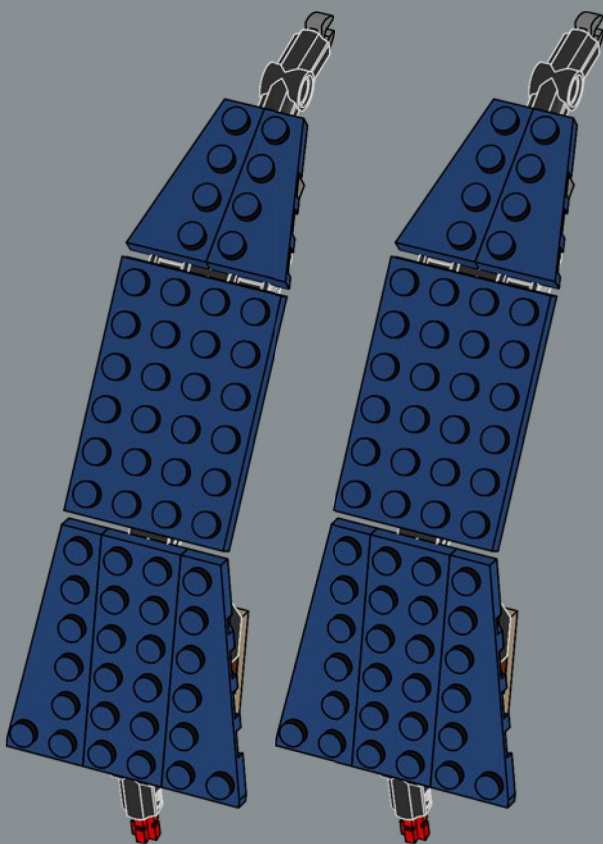
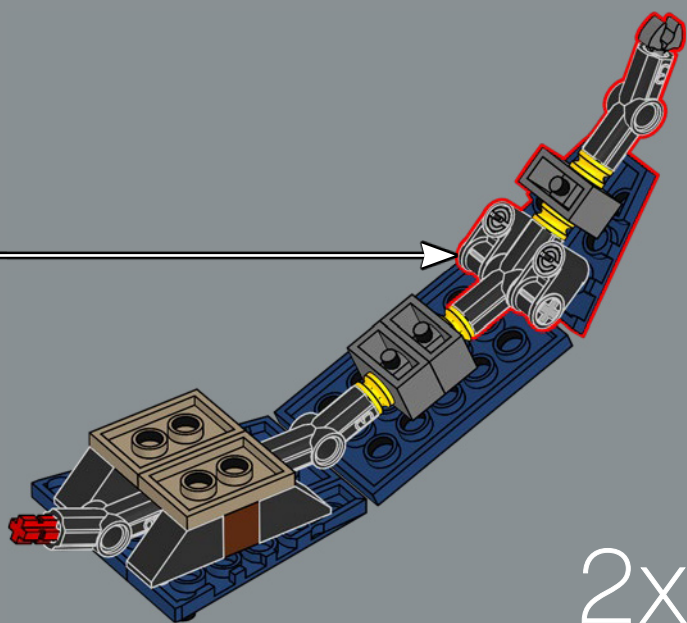

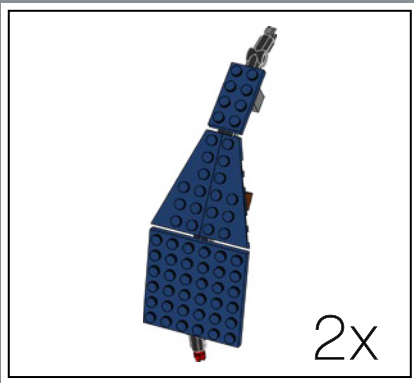

2x

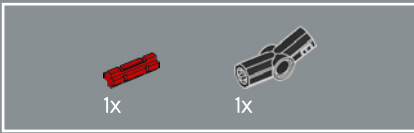

1x

1x

310

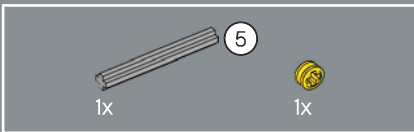
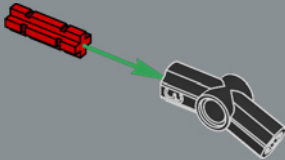

1x

1x

311

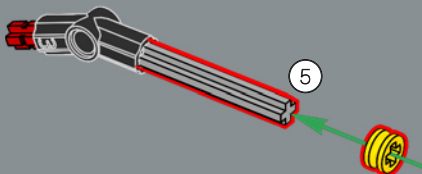

5

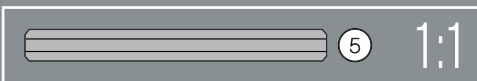

5

1:1

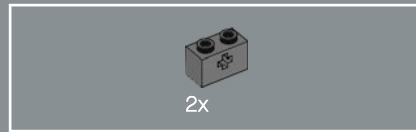

2x

312

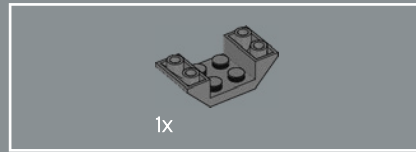
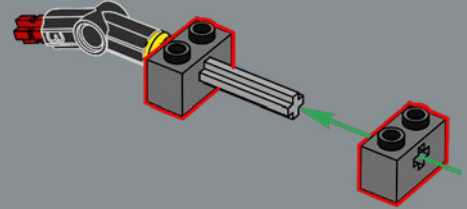

1x

313

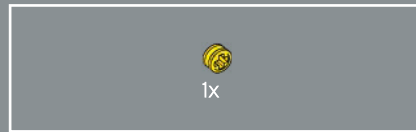
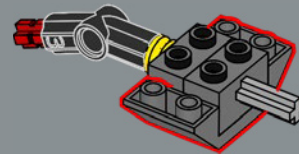

1x

314

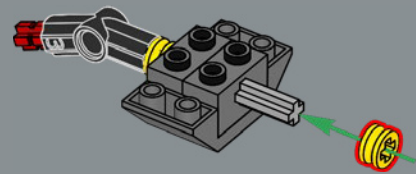

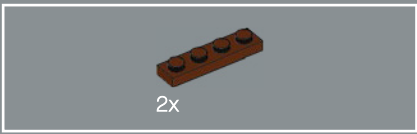

315

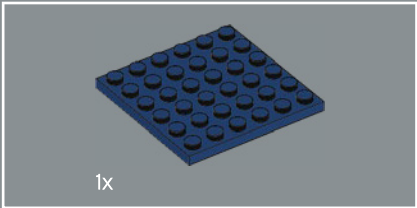
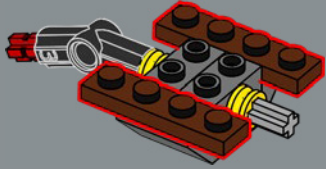

316

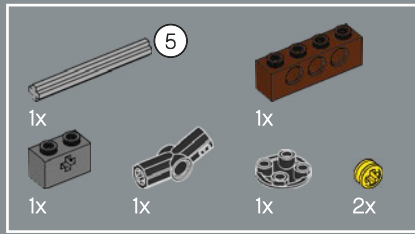
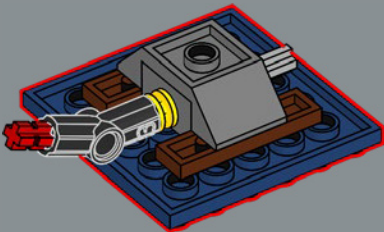

317

1

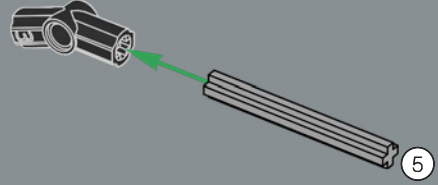

2

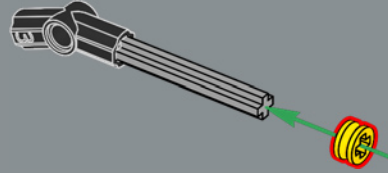

3

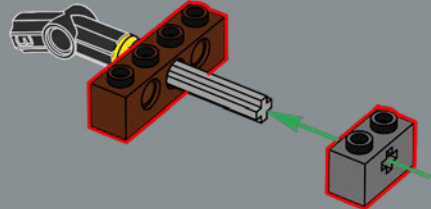

4

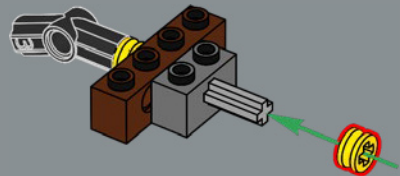

5

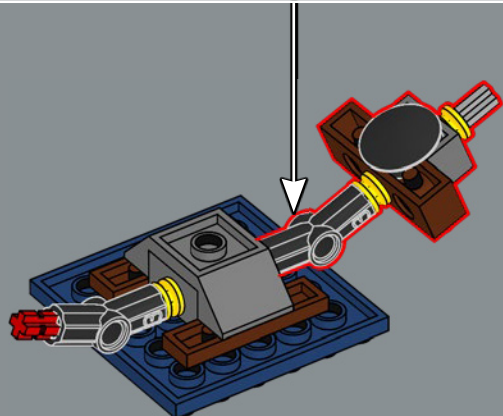

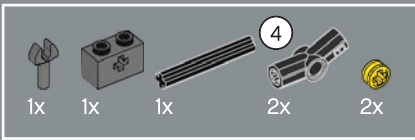

318

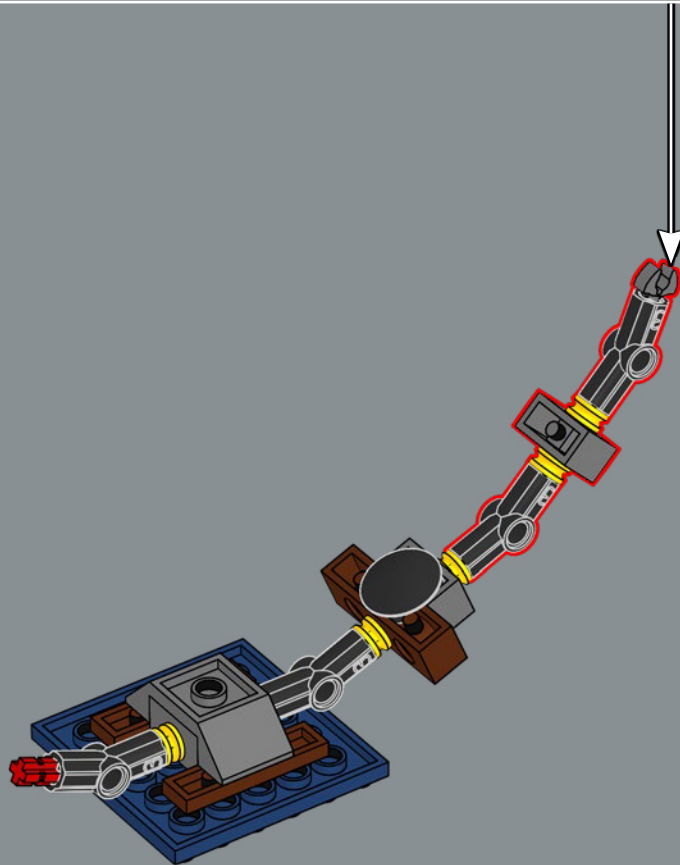
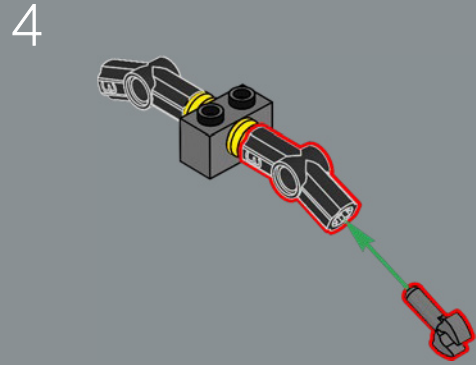
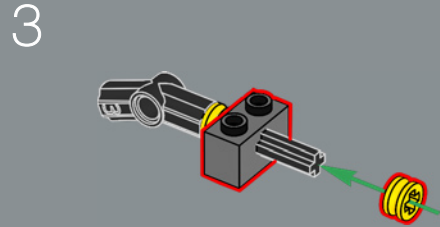
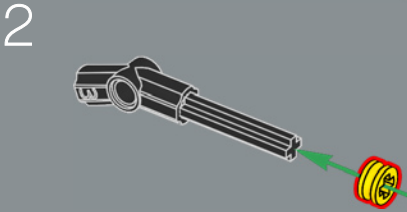
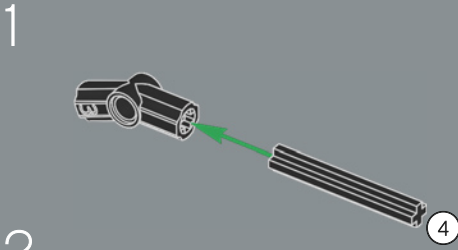

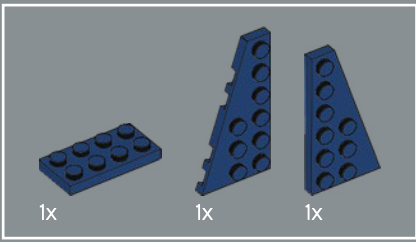

319

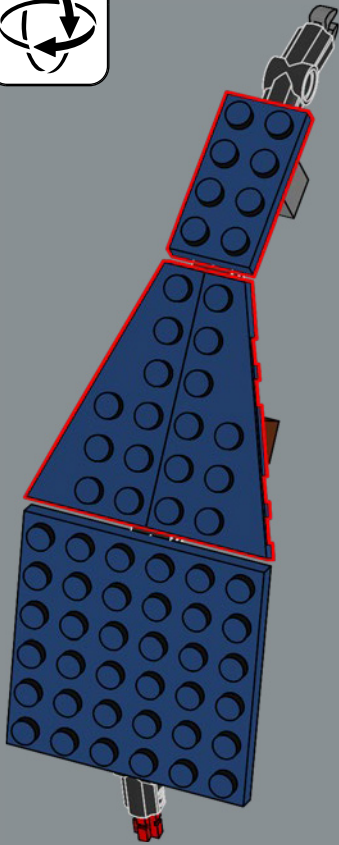

2x

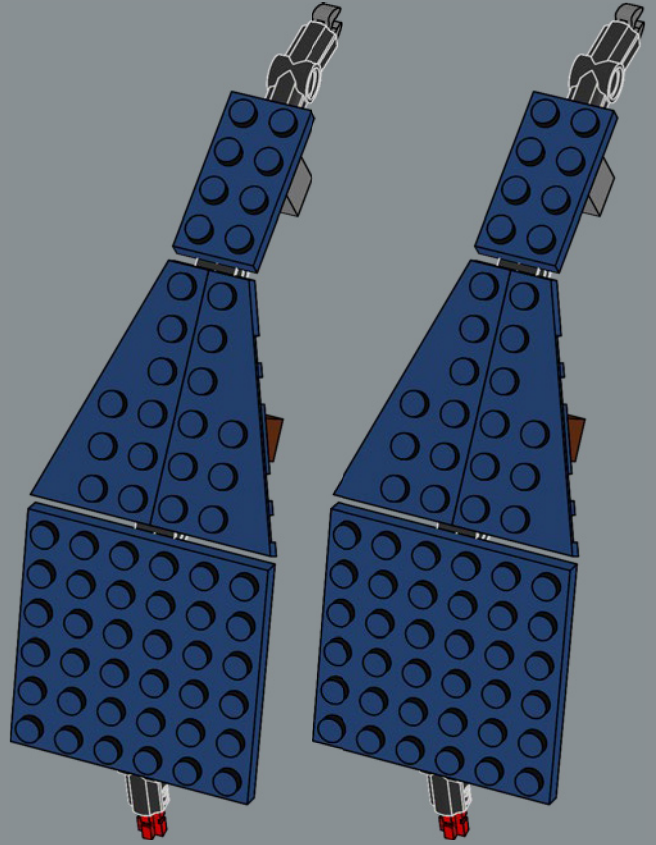

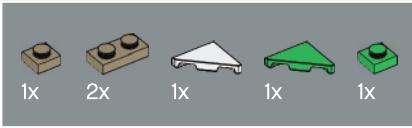
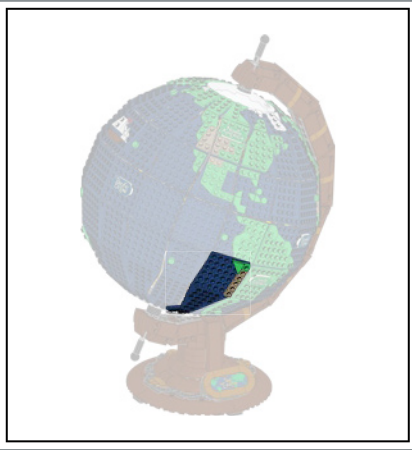

320

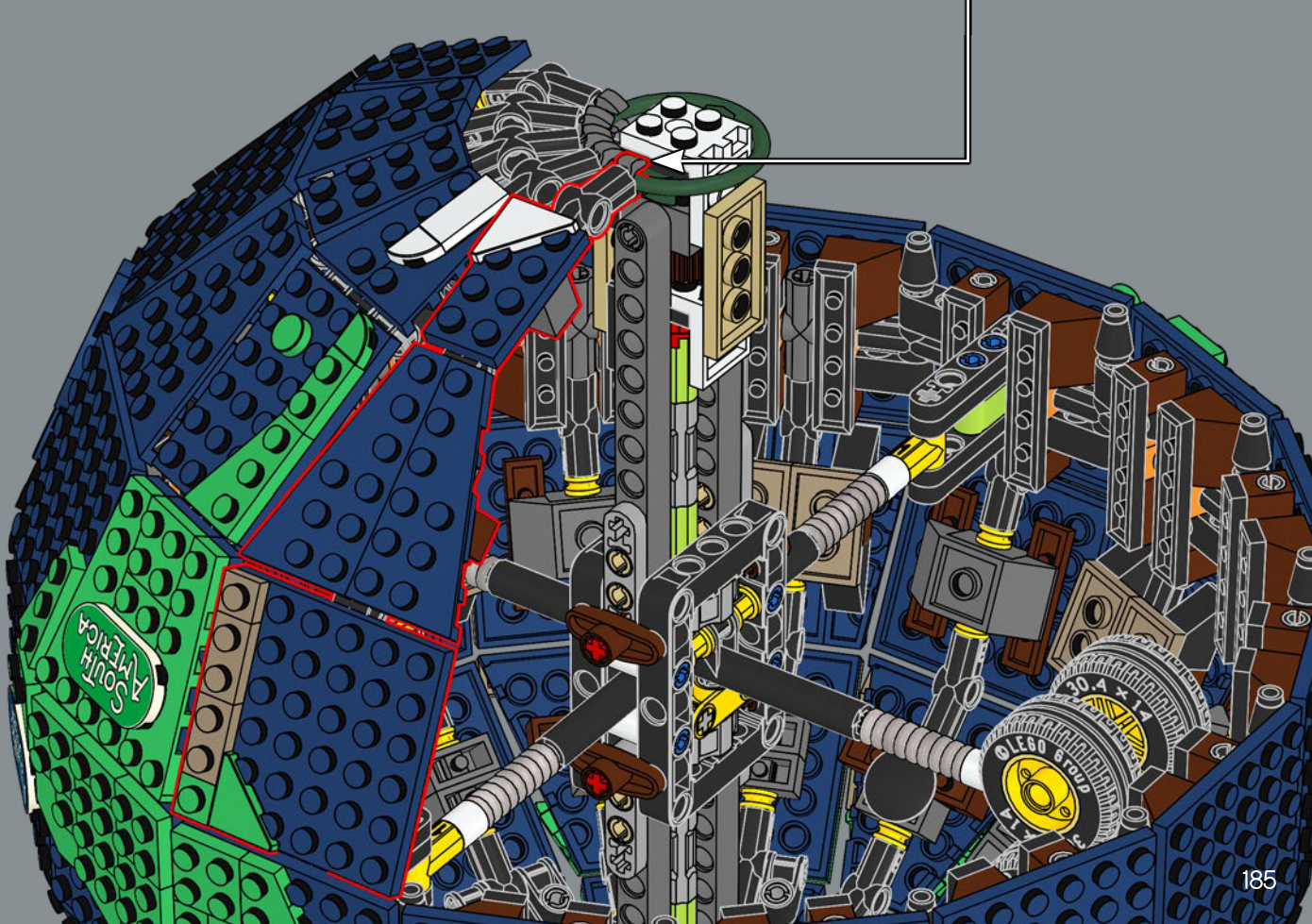
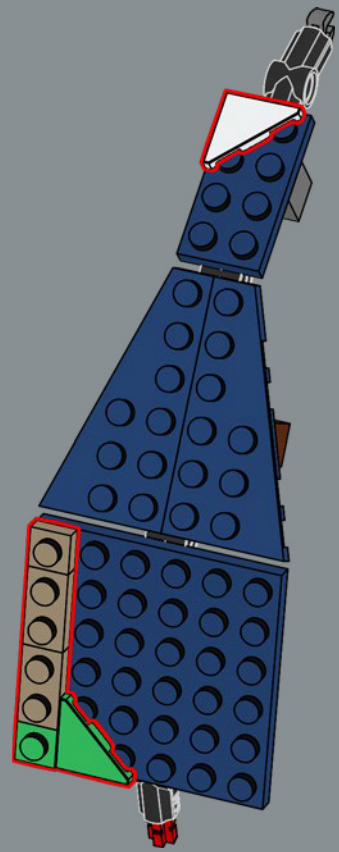



321

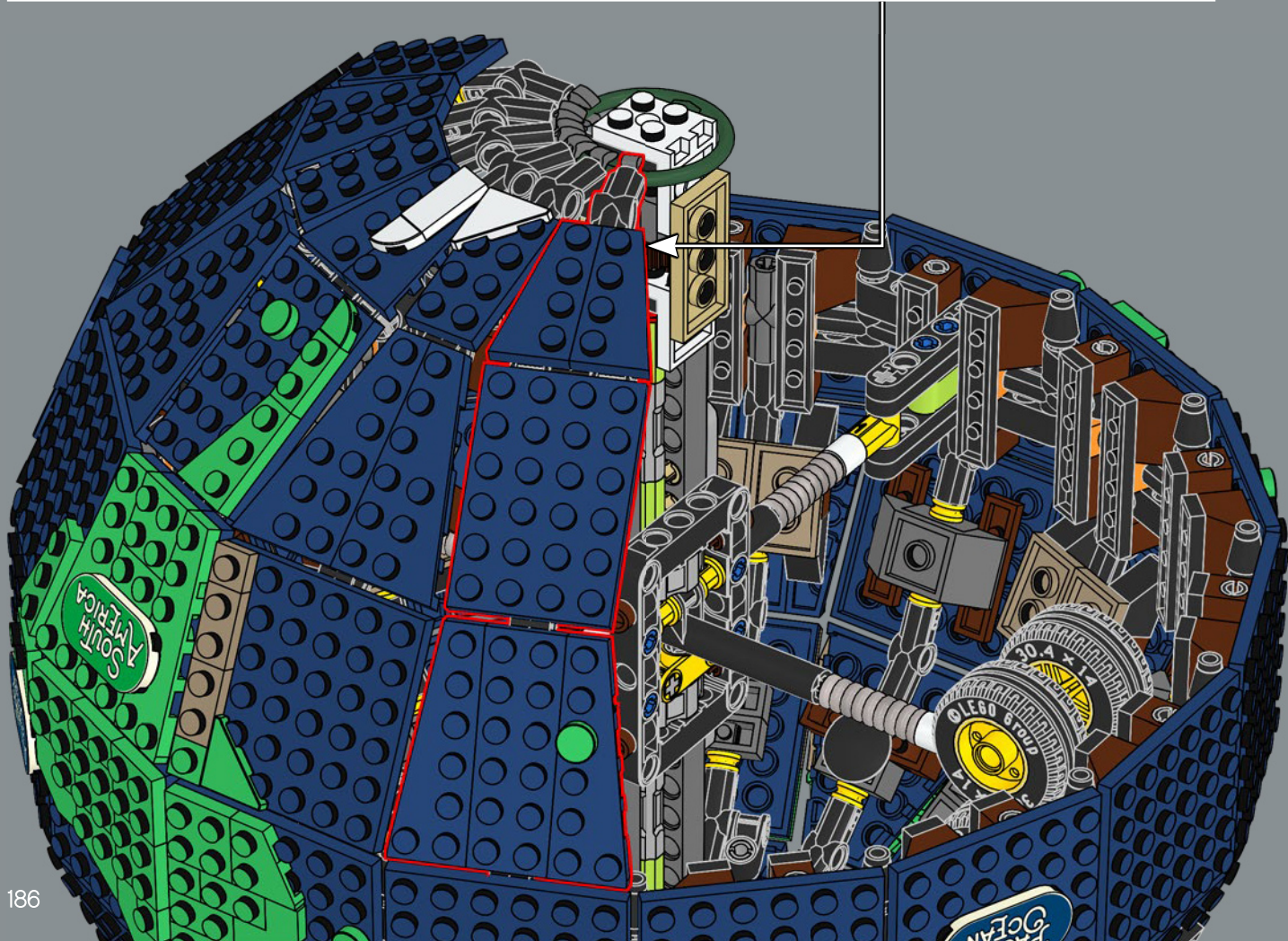
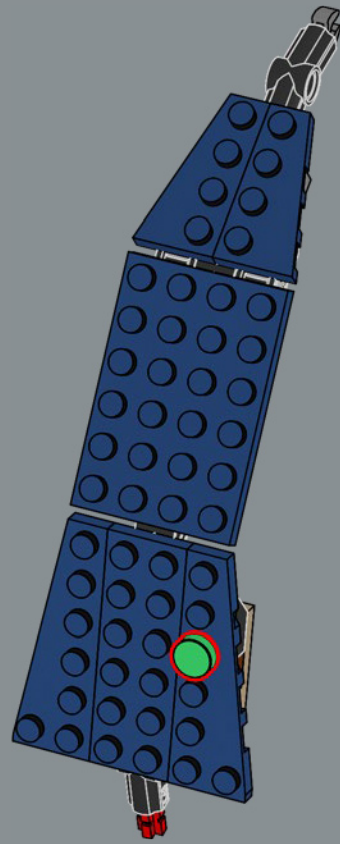



322

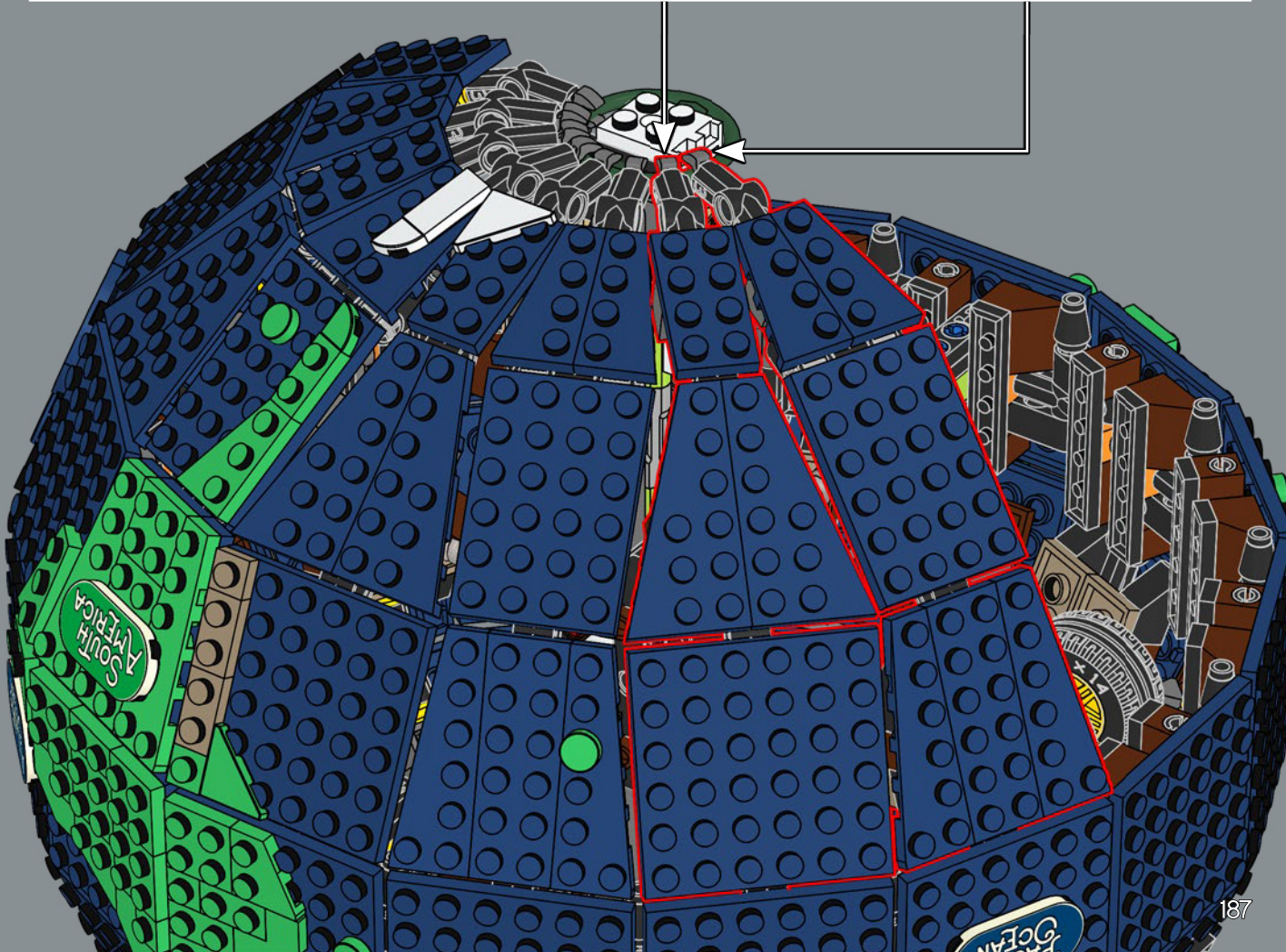
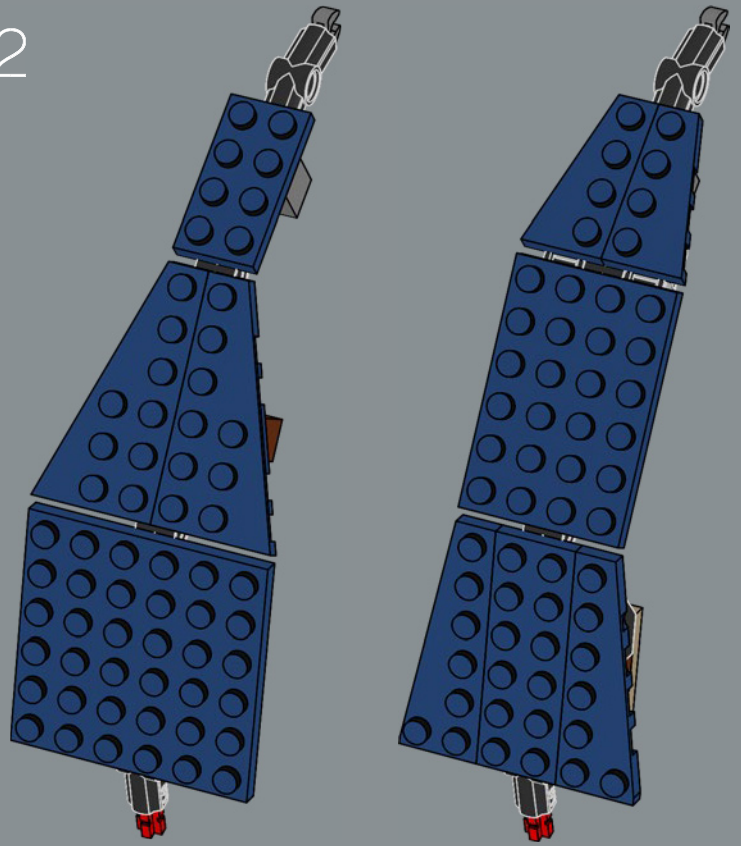

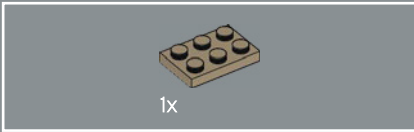
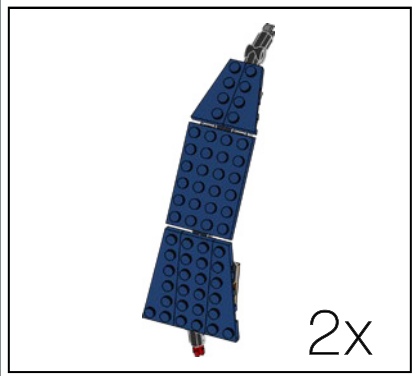
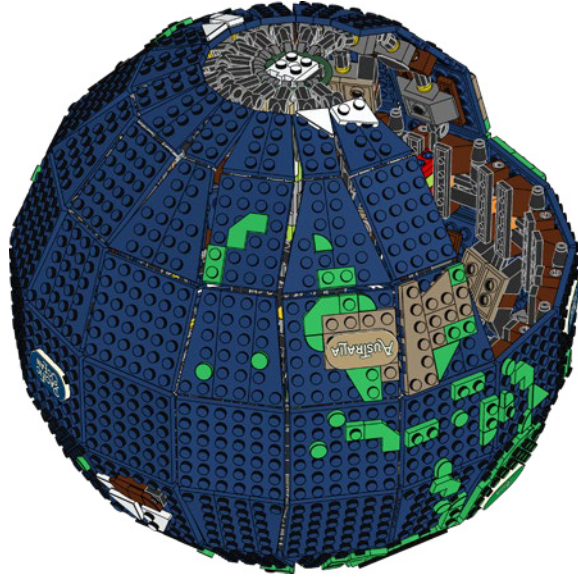

323

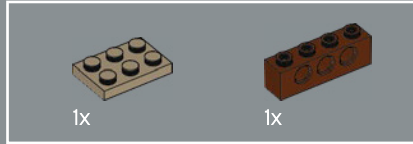

324

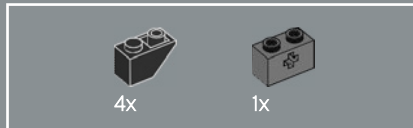
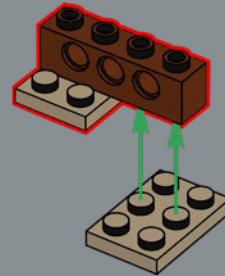

325

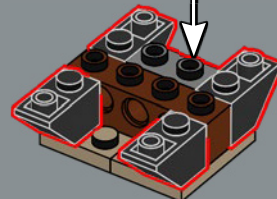
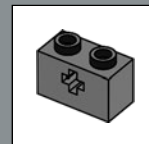

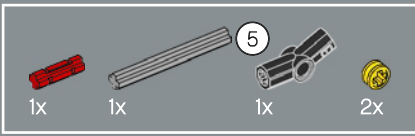

326

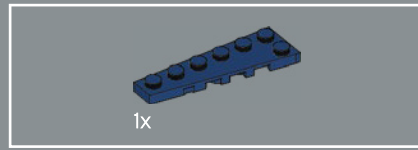
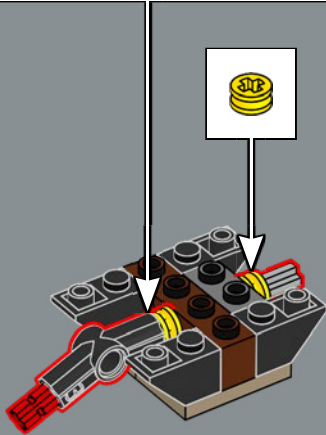
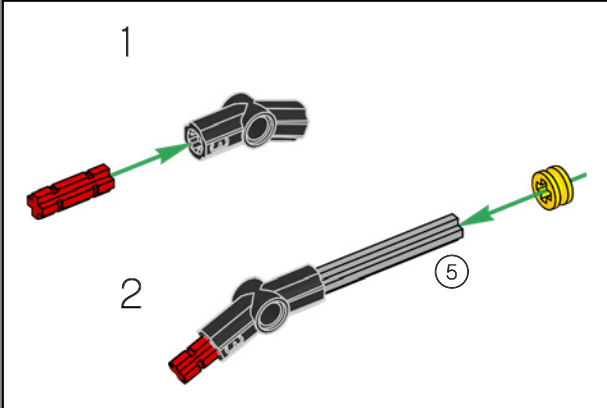

327

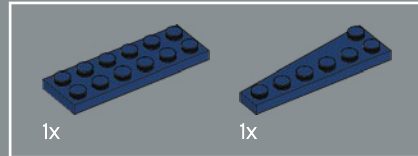
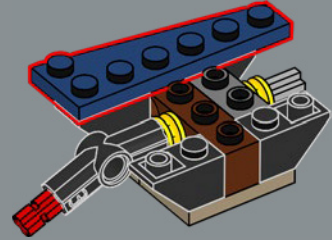

328

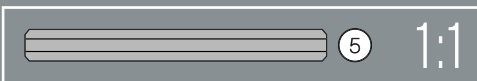
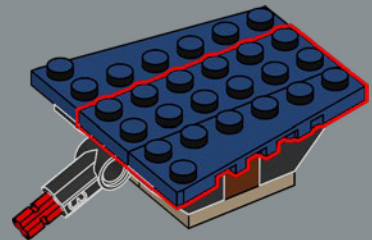

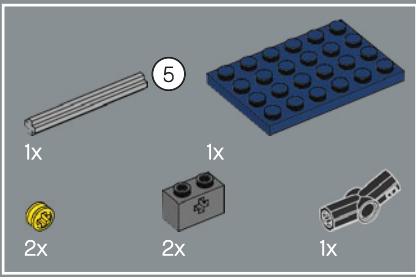

329

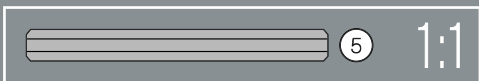
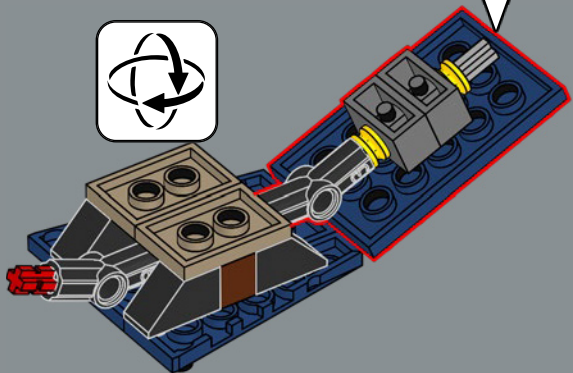
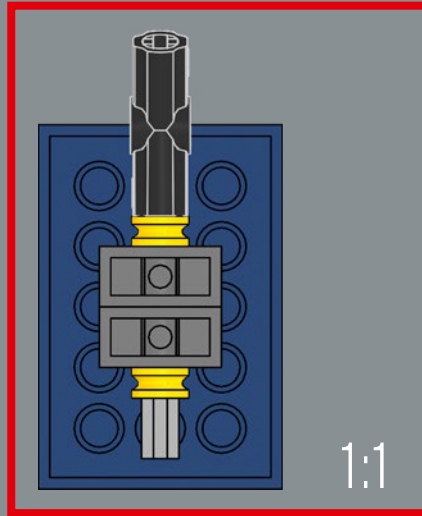
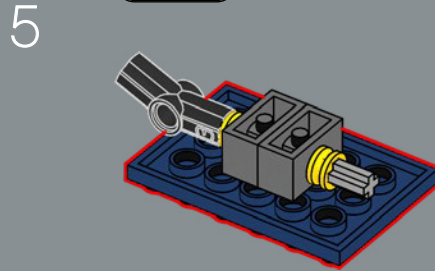
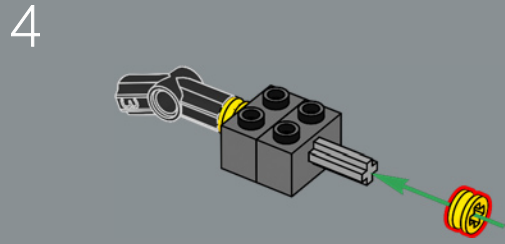
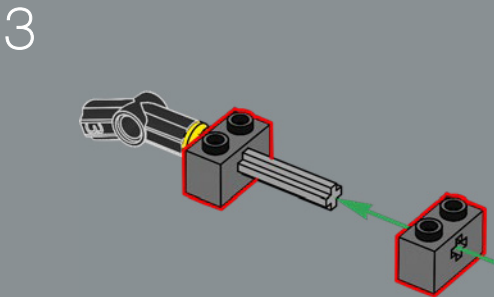
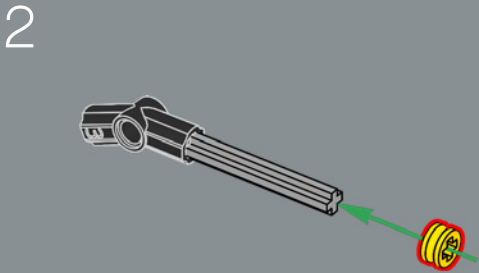
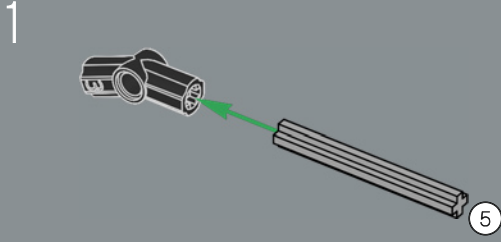

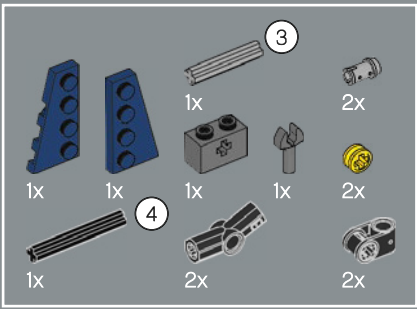

330

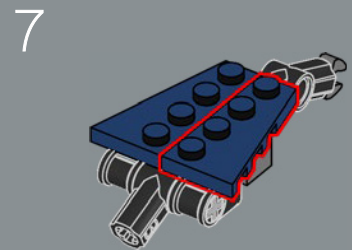
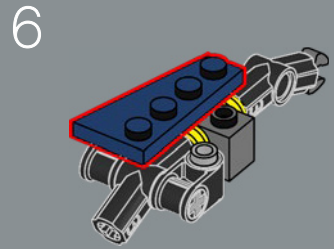
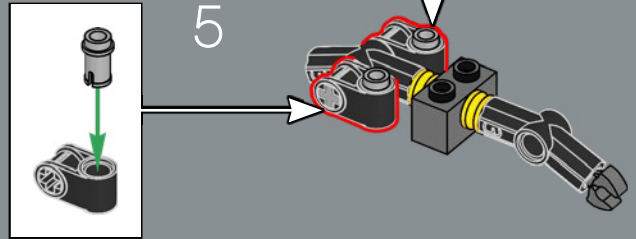
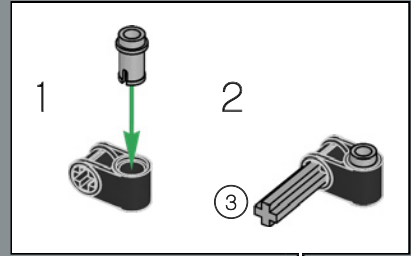
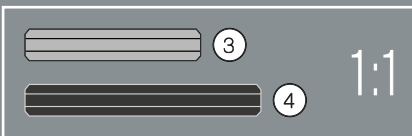
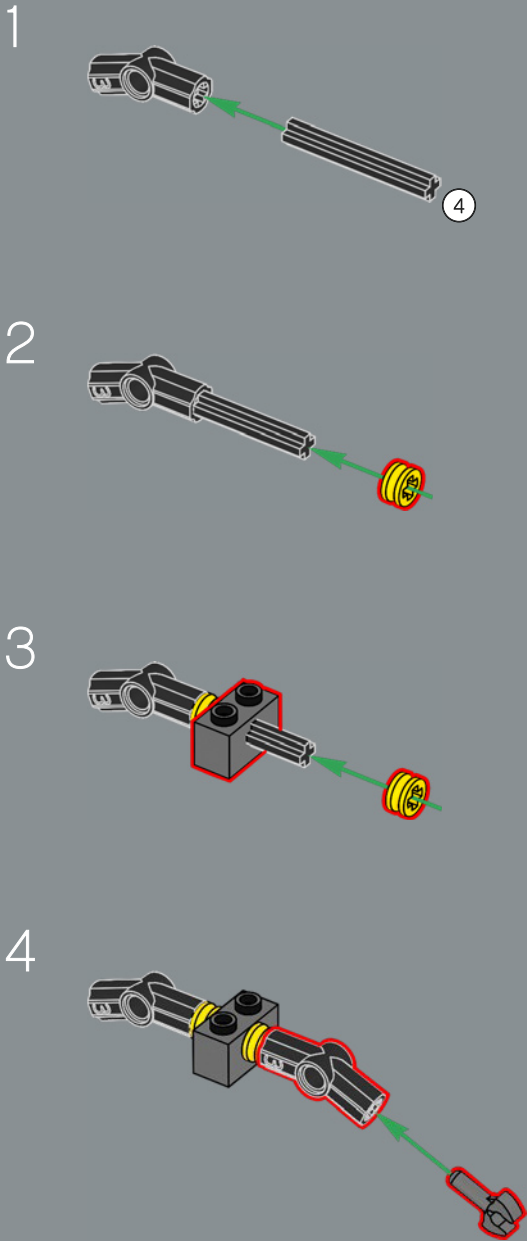

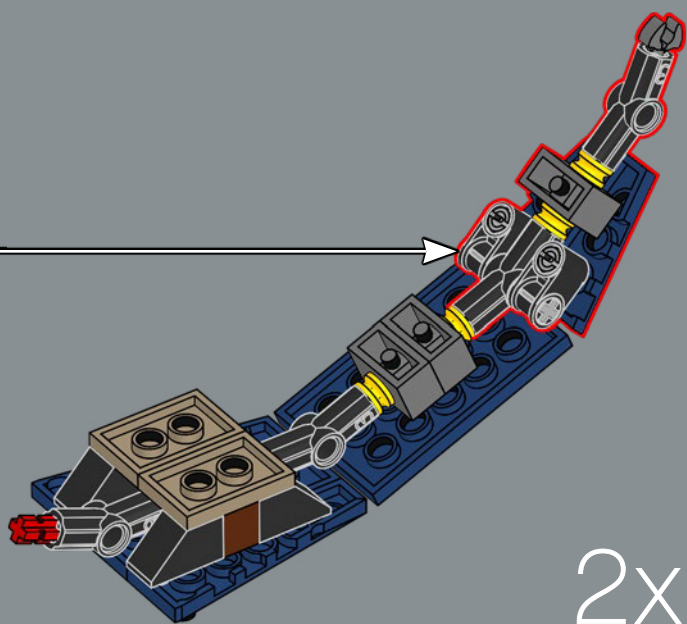

2x

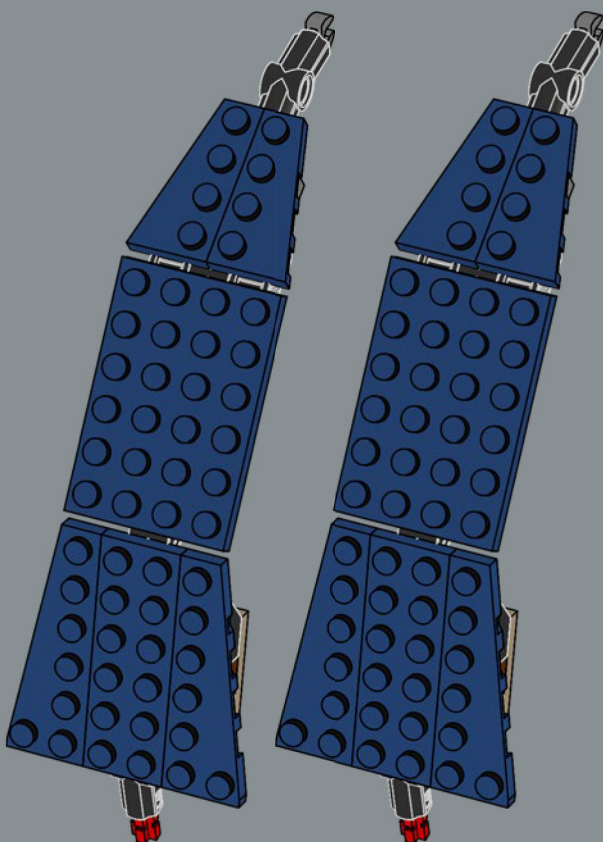

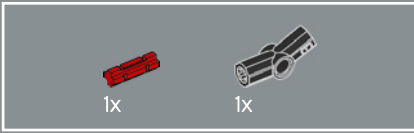
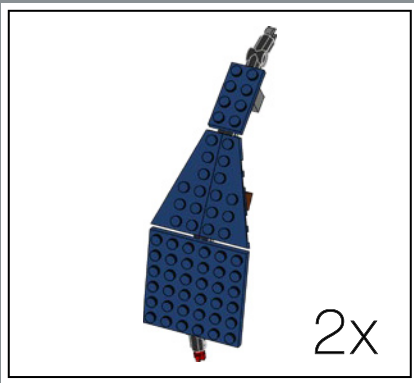

331

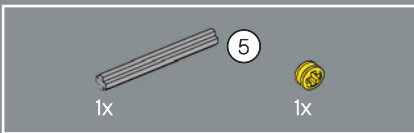
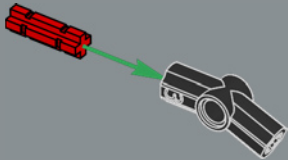

332

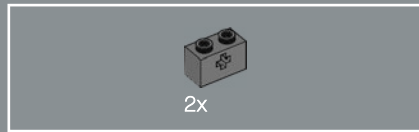
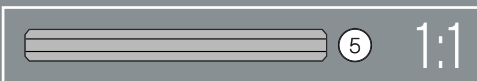
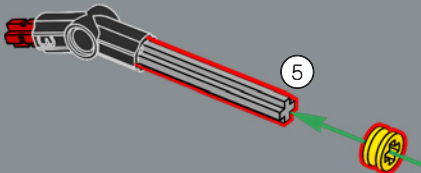

333

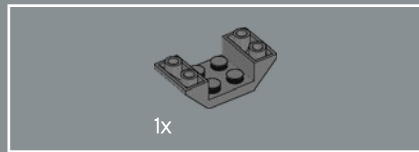
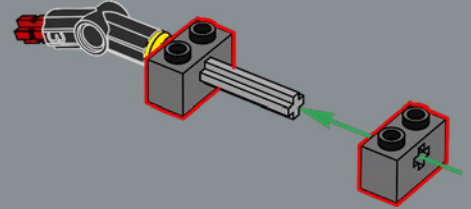

334

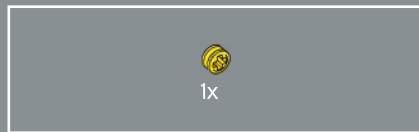
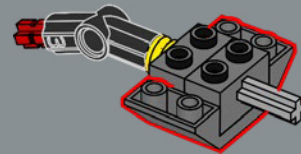

335

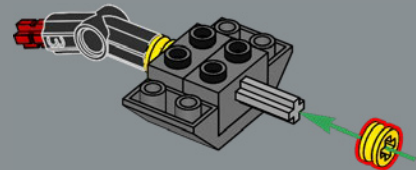

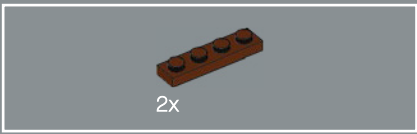

2x

336

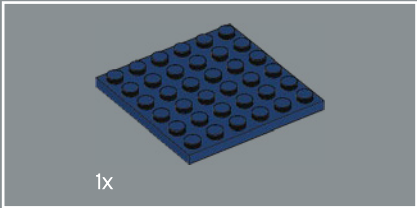
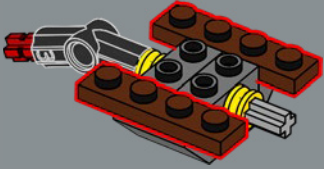

1x

337

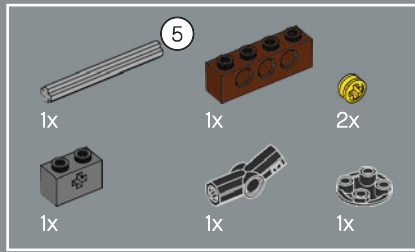
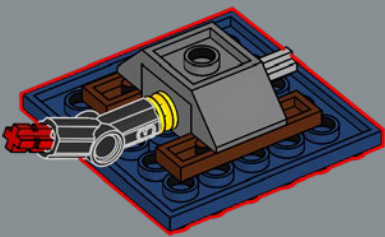

1x

1x

2x

1x

1x

1x

338

1

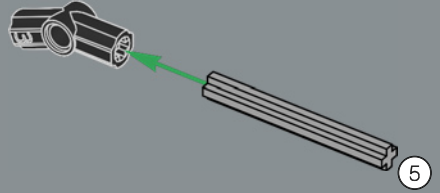

2

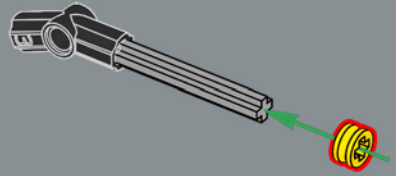

3

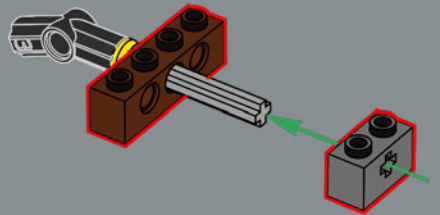

4

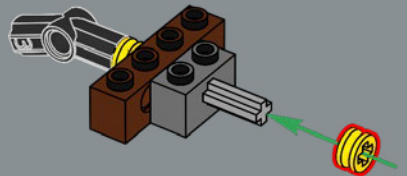

5

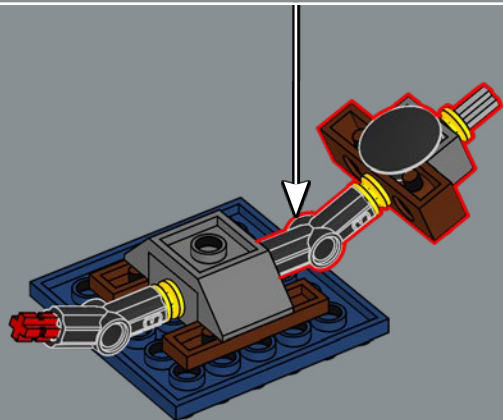
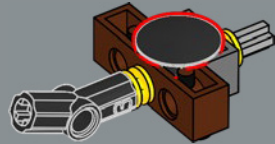

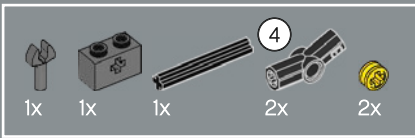

339

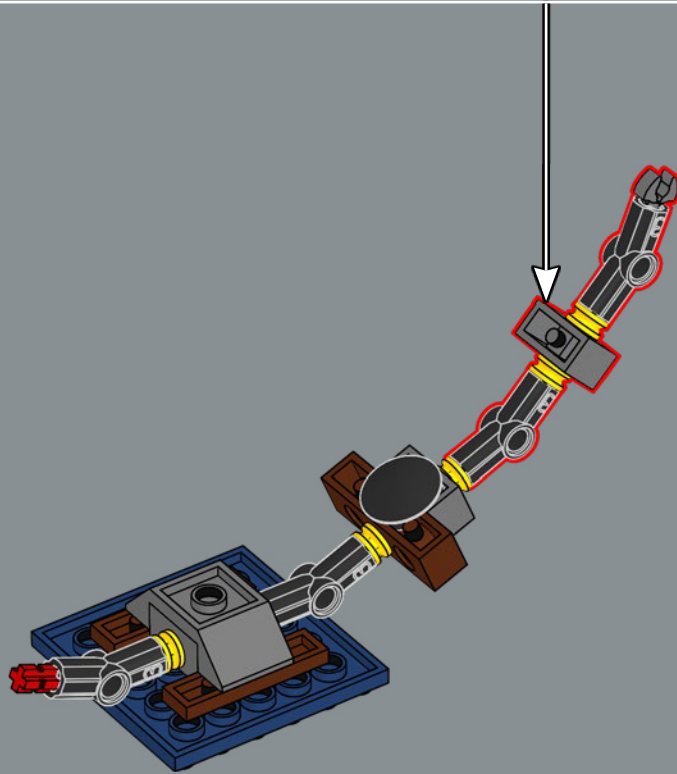
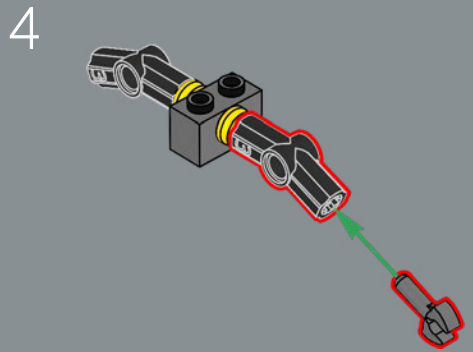
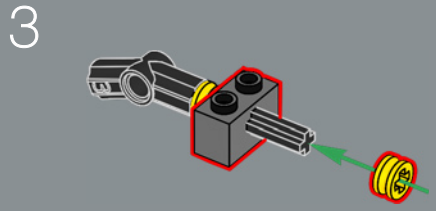
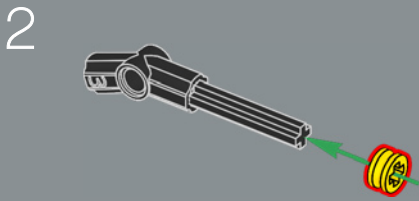
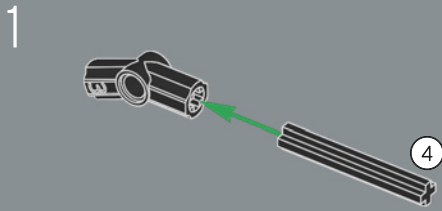

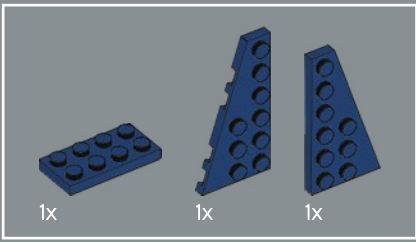

340

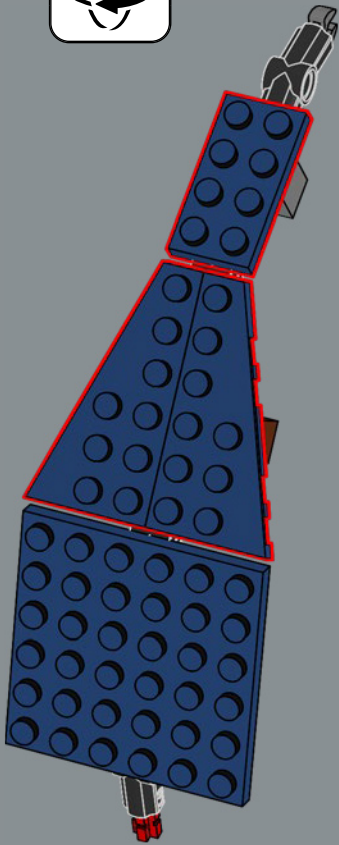

2x

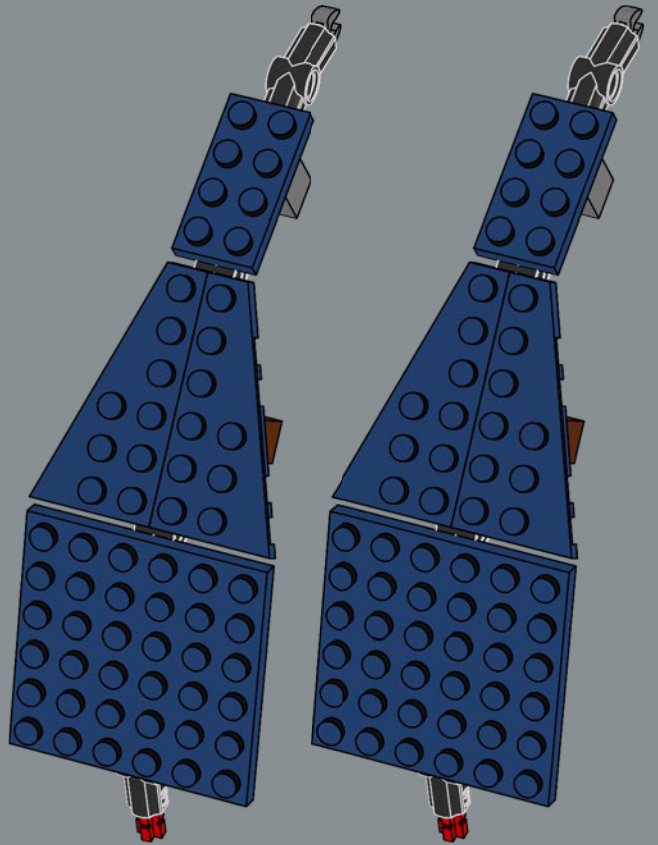

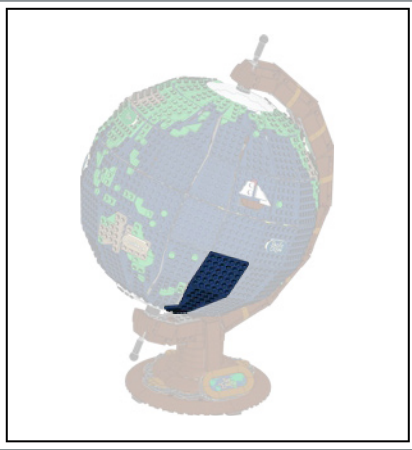

341

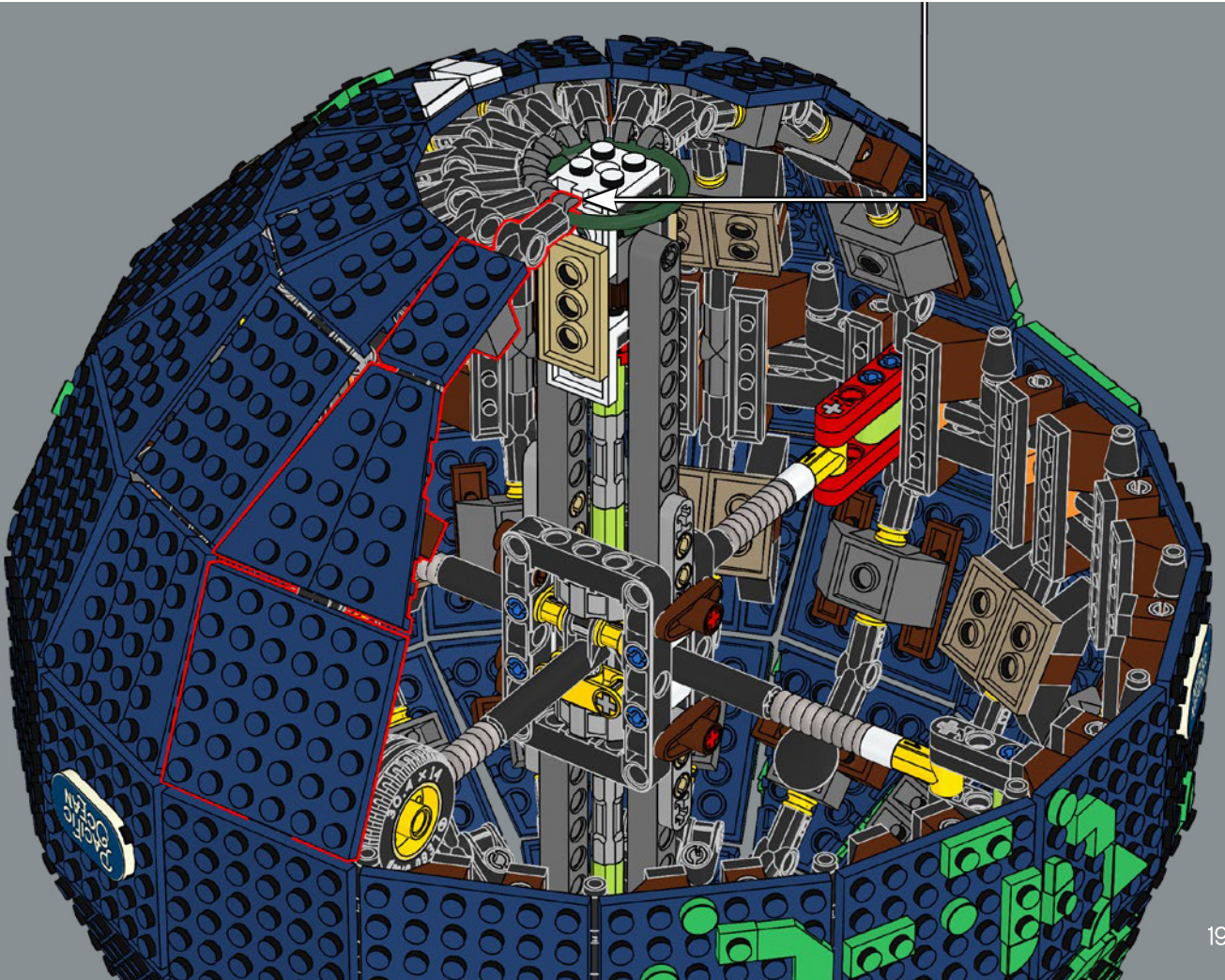
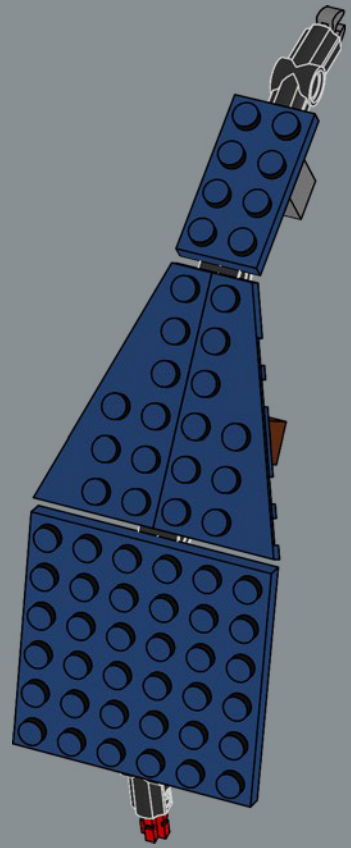

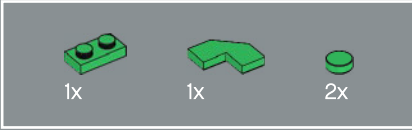

342

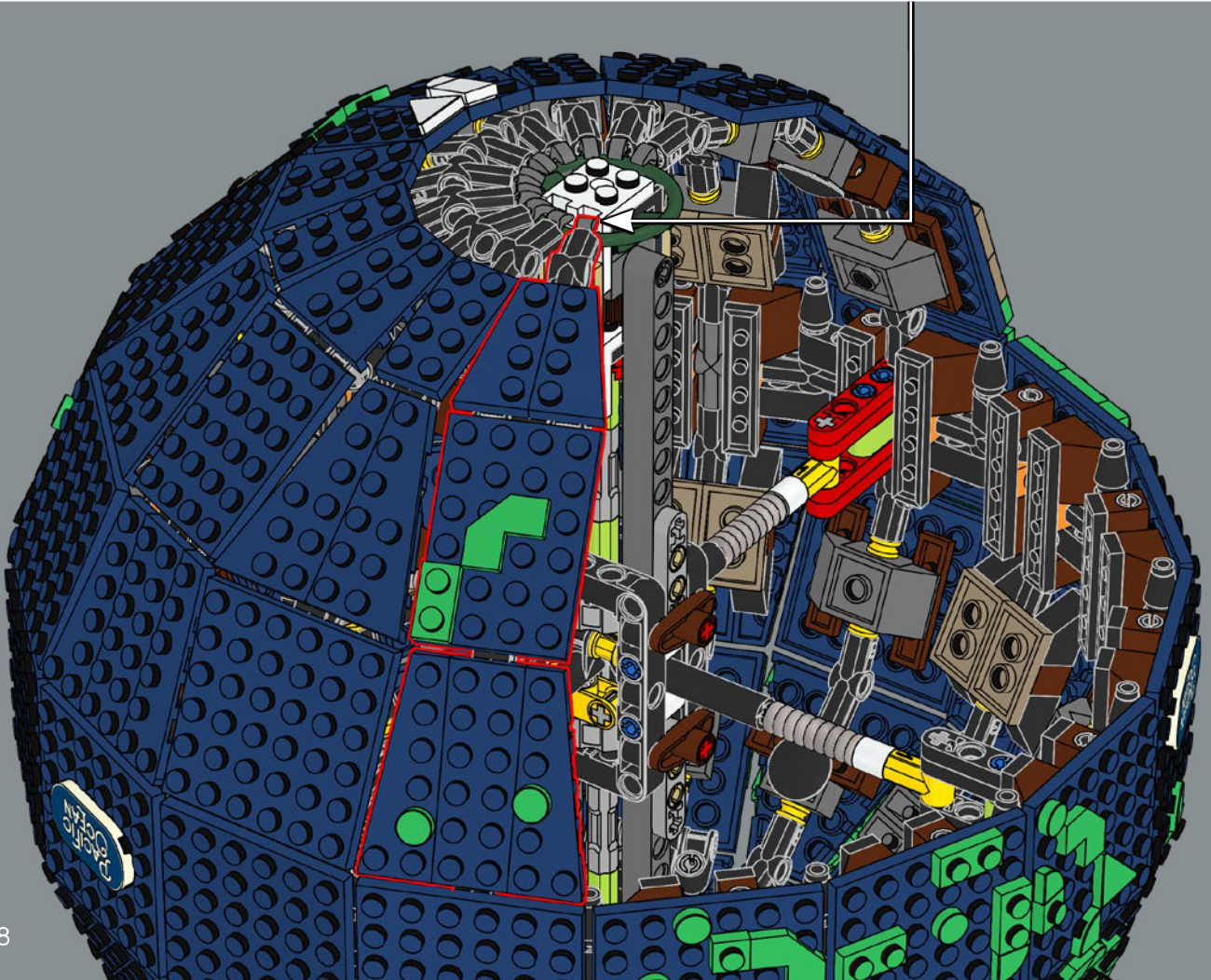
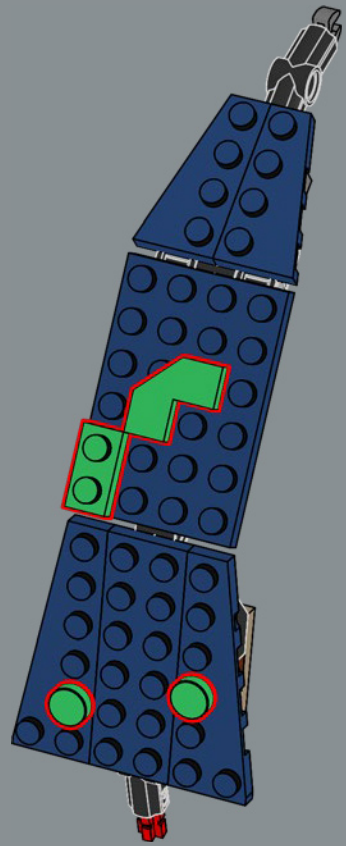

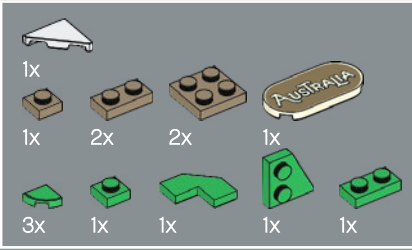
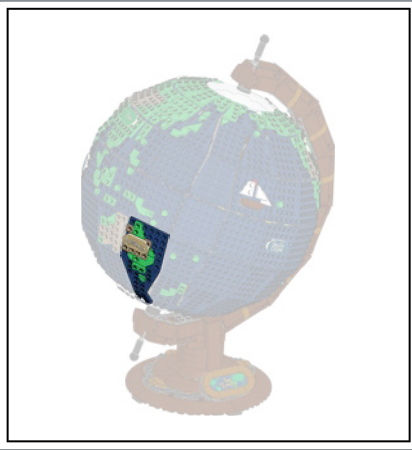

343

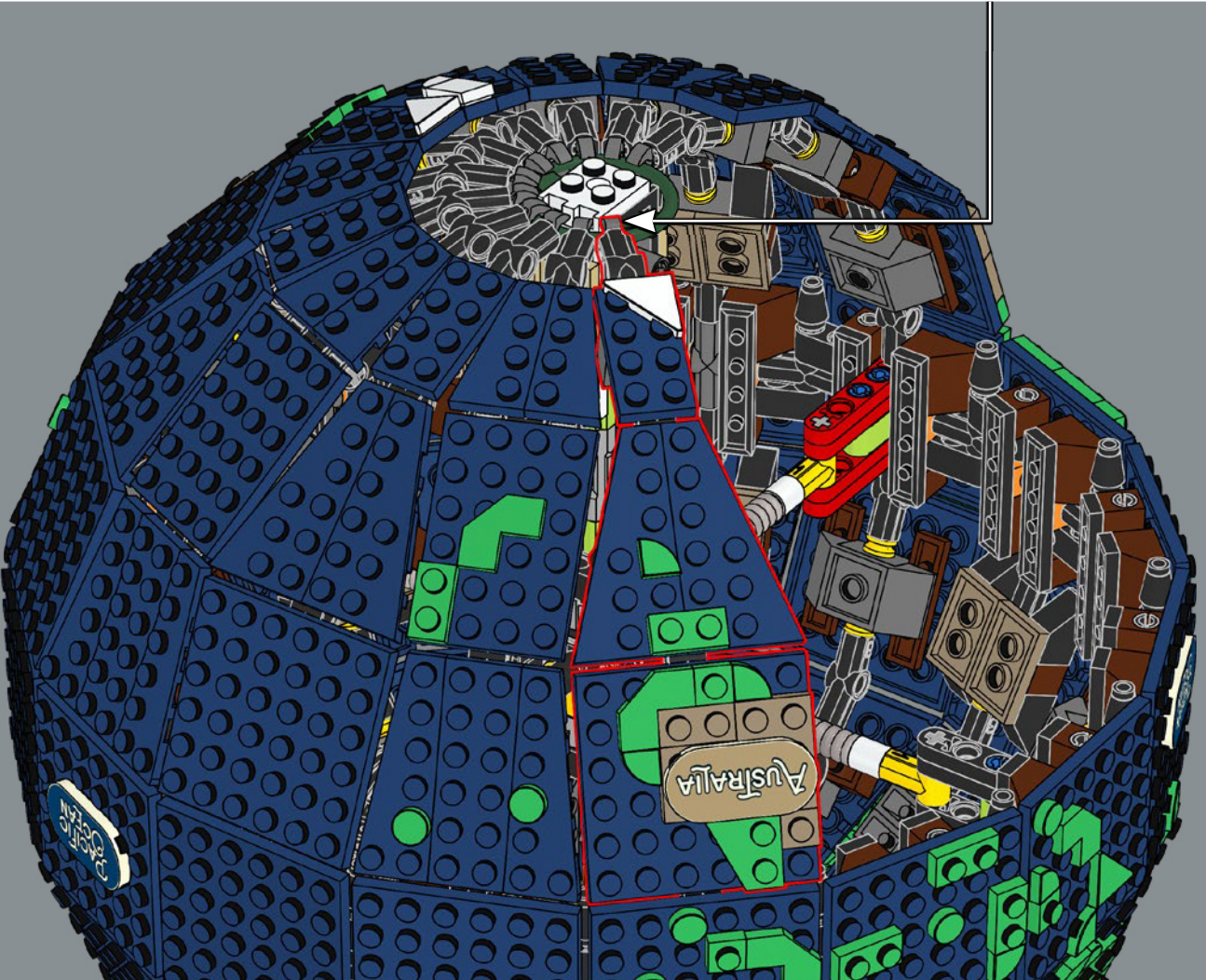
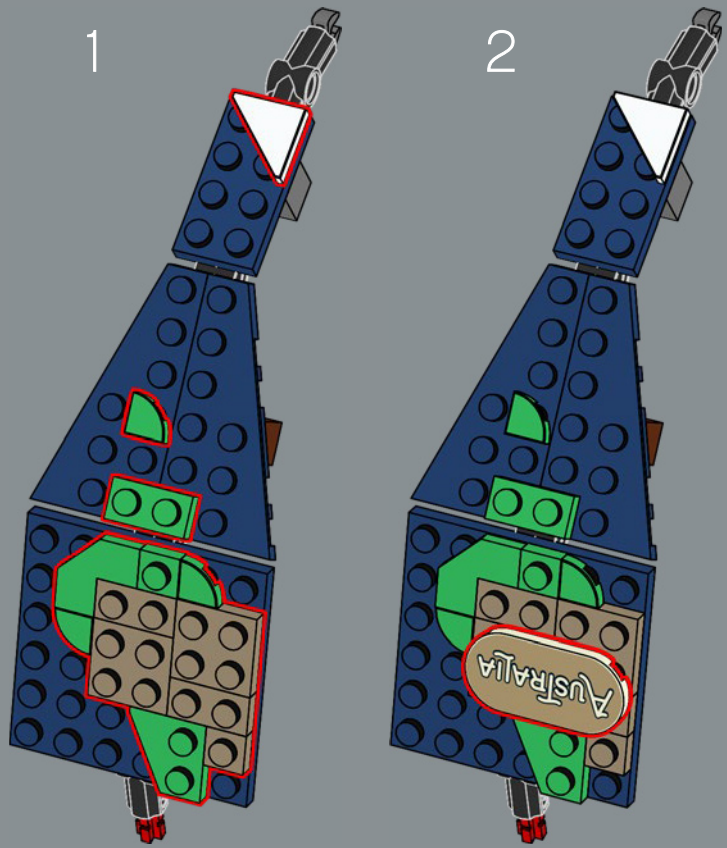

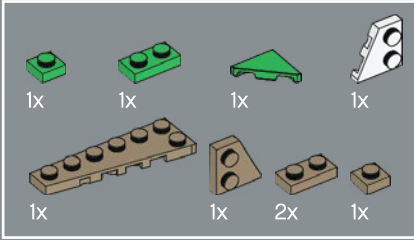
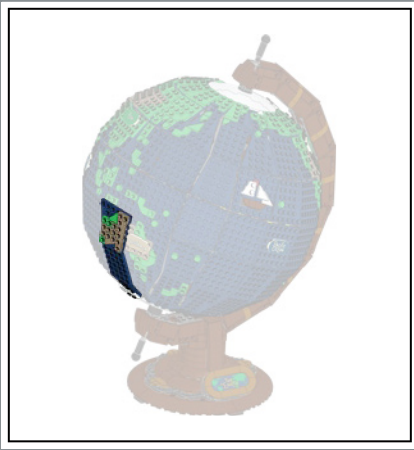

344

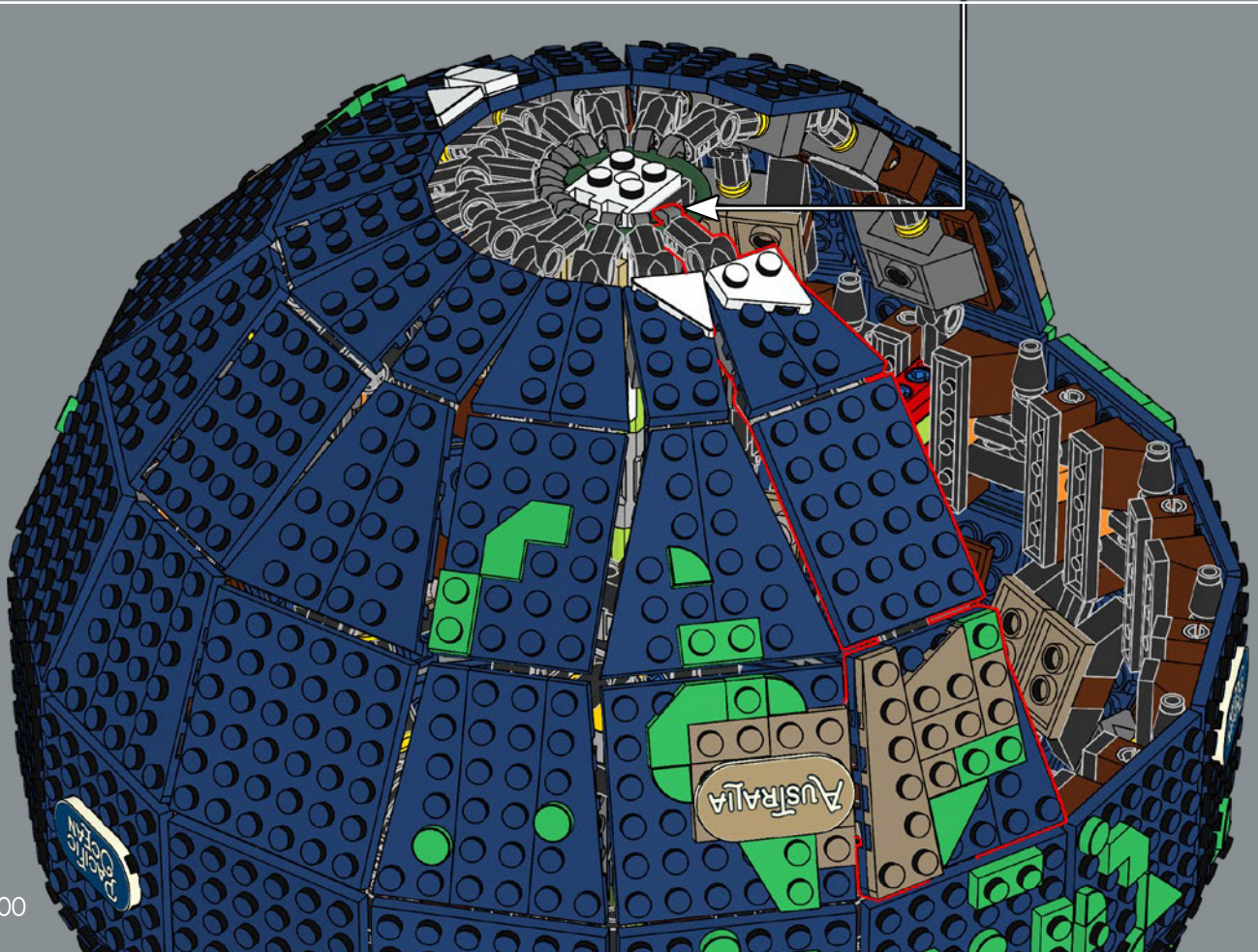
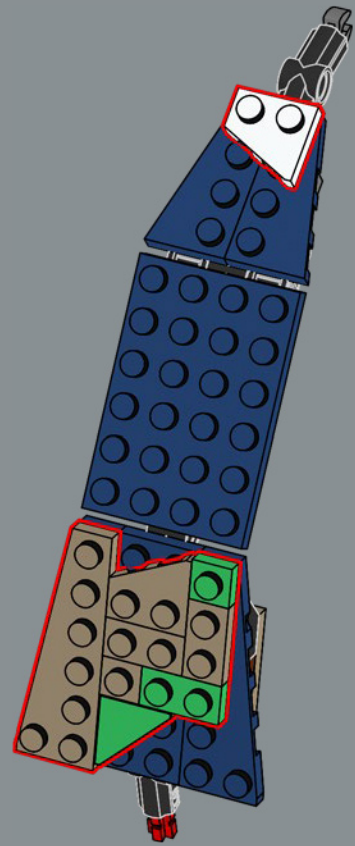

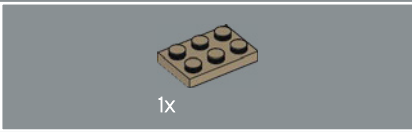
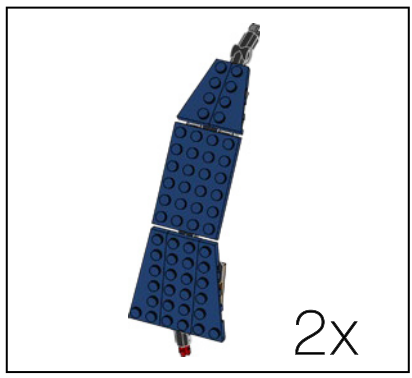
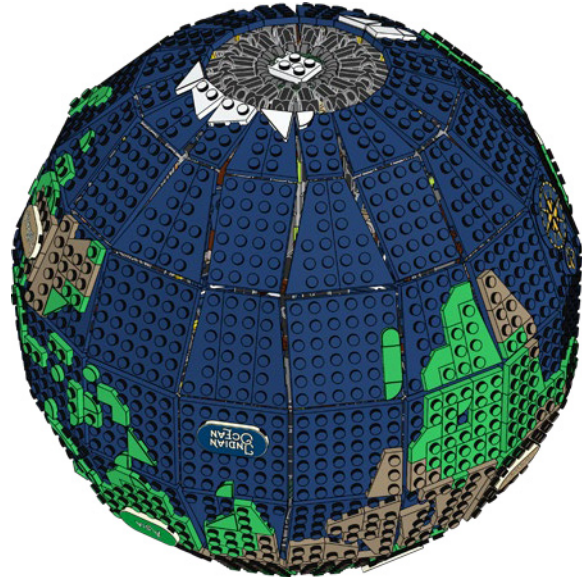

345



346

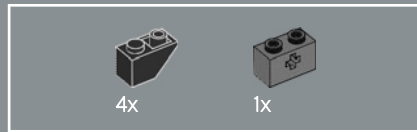
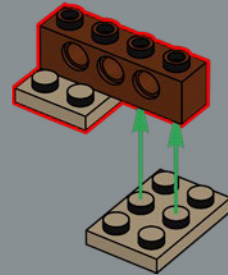

347

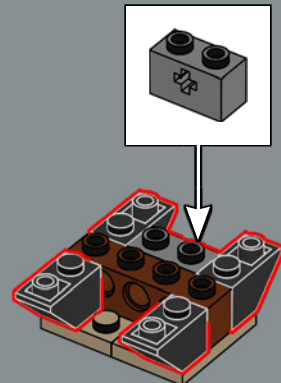

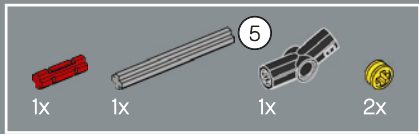

348

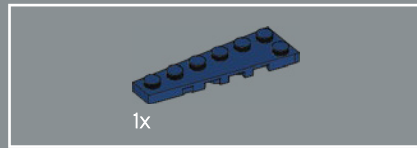
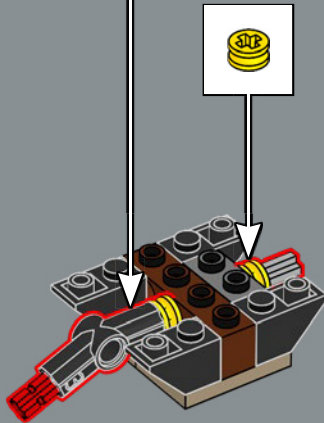
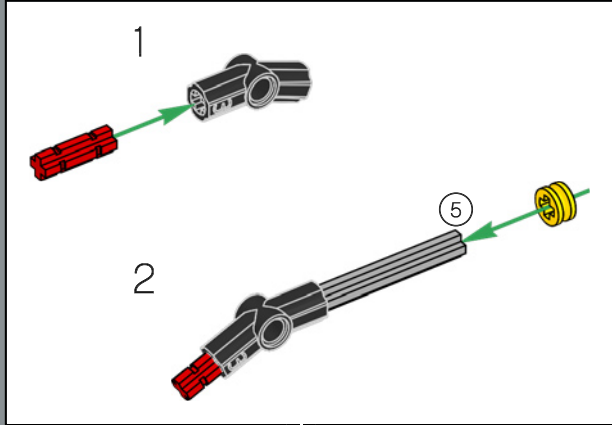

349

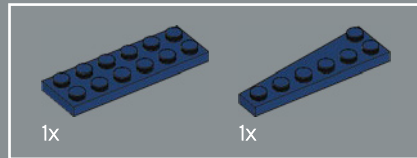
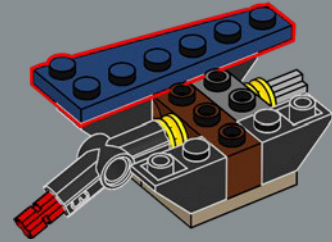

350

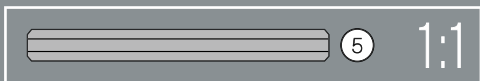
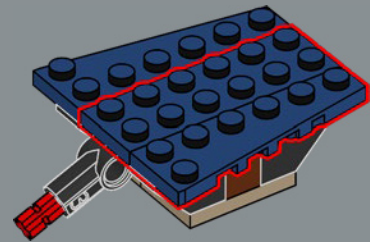

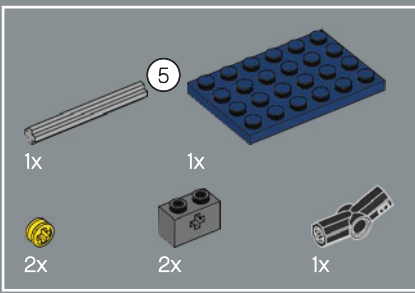

351

1

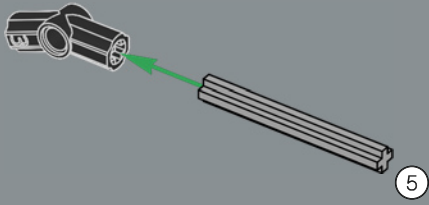

2

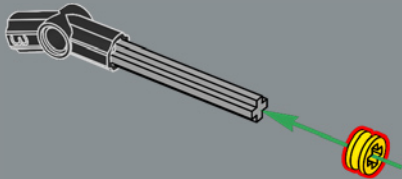

3

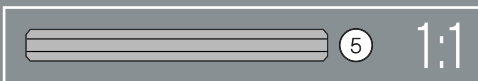
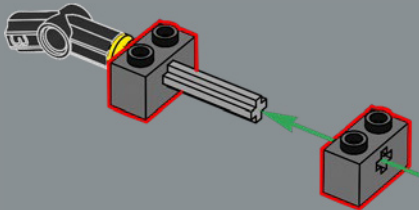

4

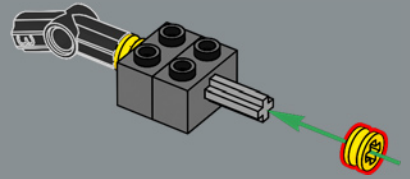

5

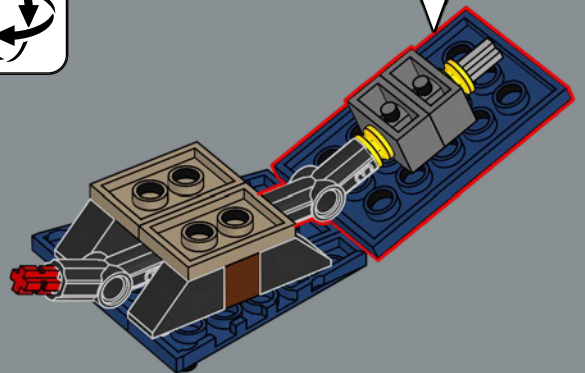
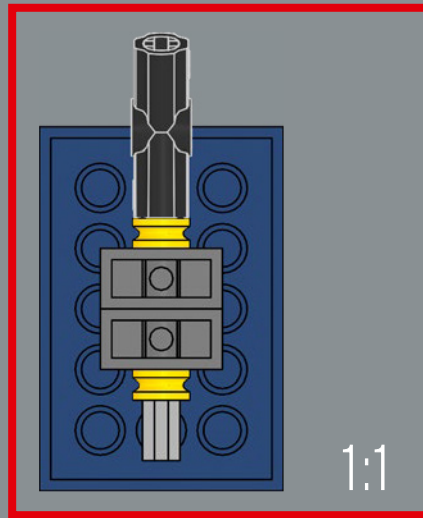
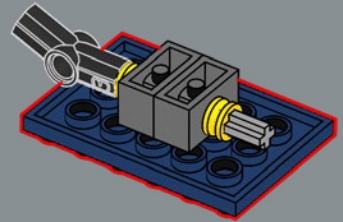

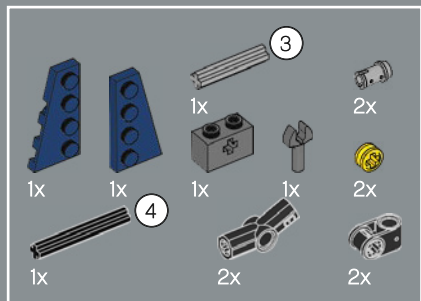

352

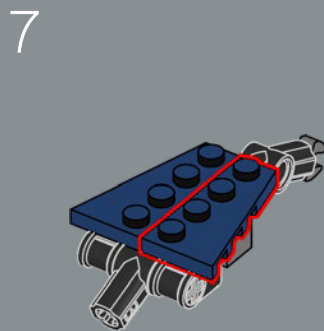
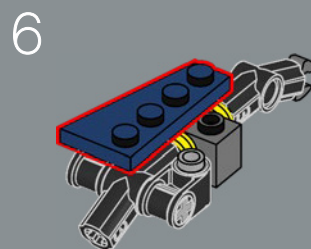
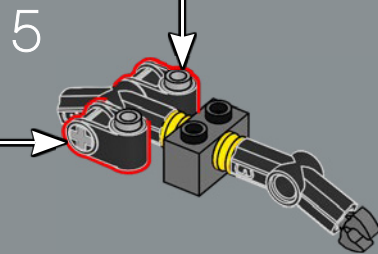
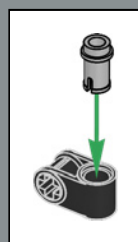
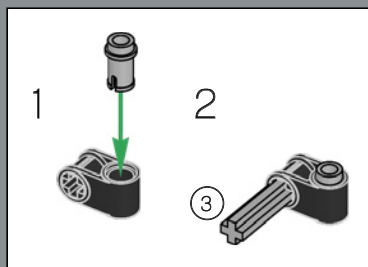
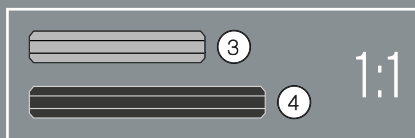
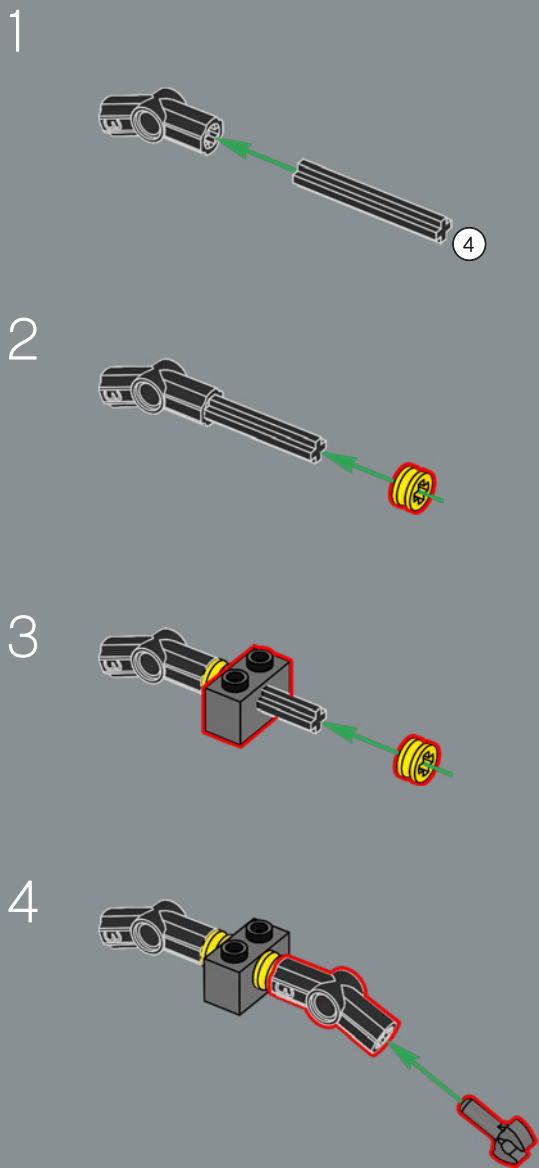

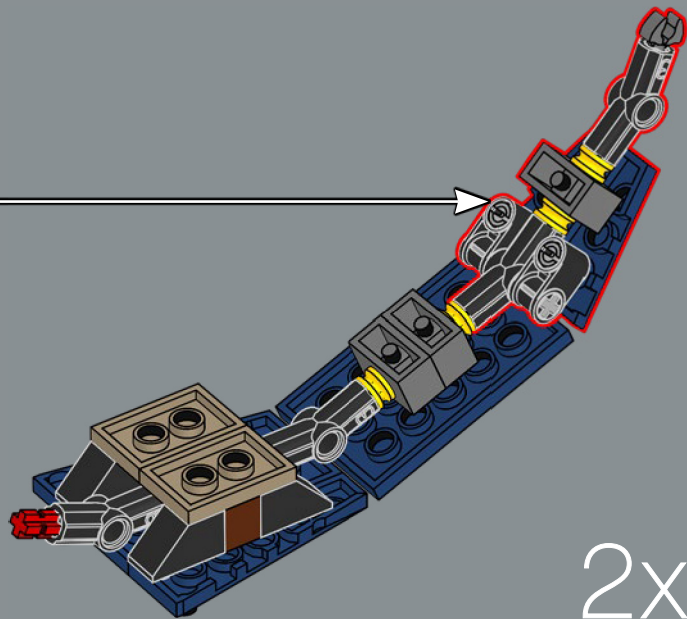

2x

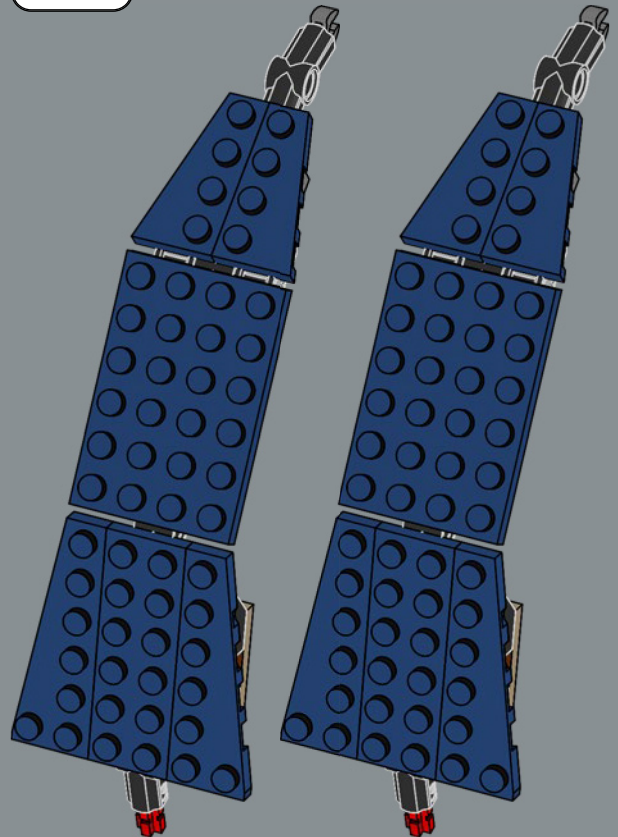

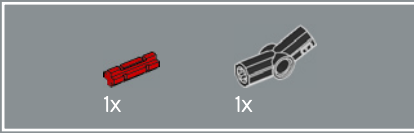
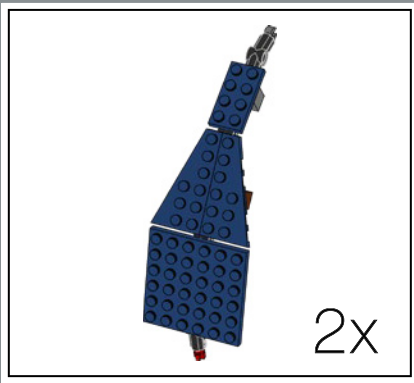

353

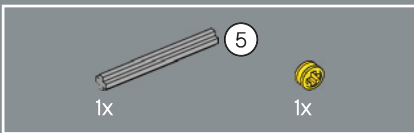
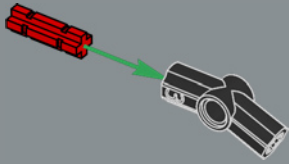

354

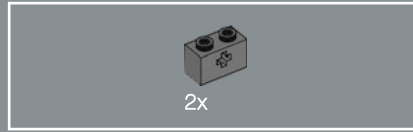
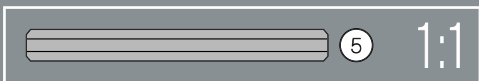
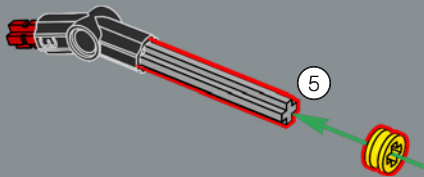

355

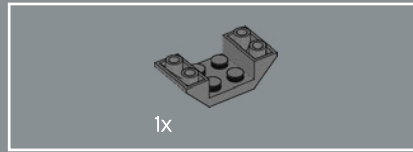
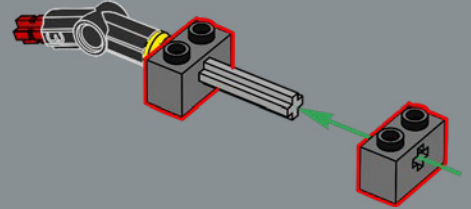

356

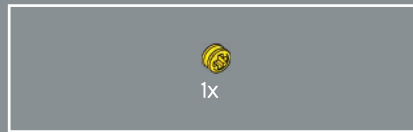
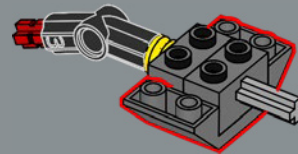

357

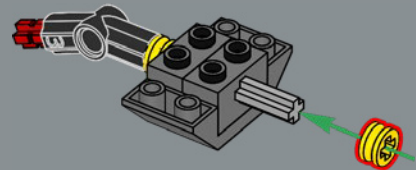

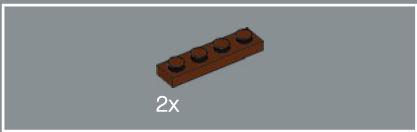

2x

358

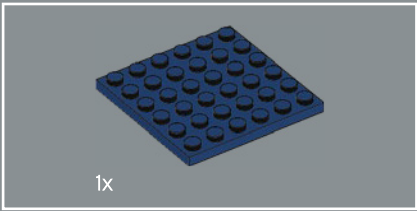
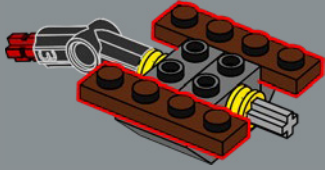

1x

359

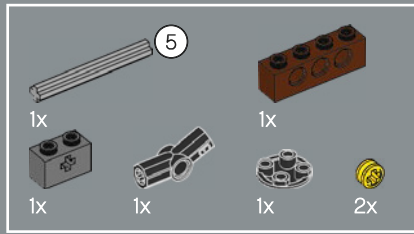
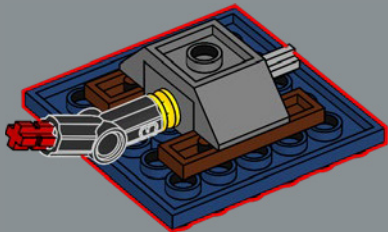

360

1

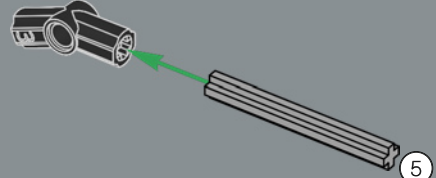

2

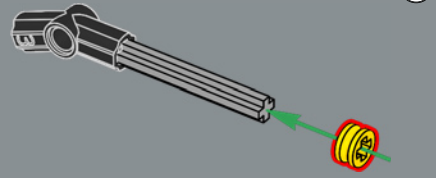

3

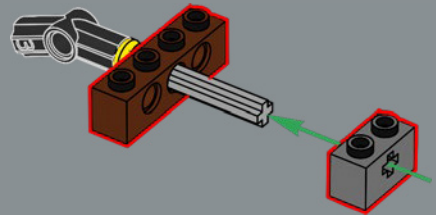

4

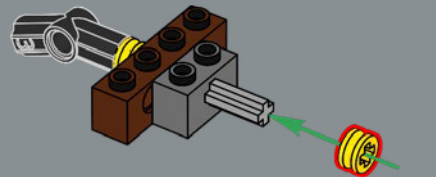

5

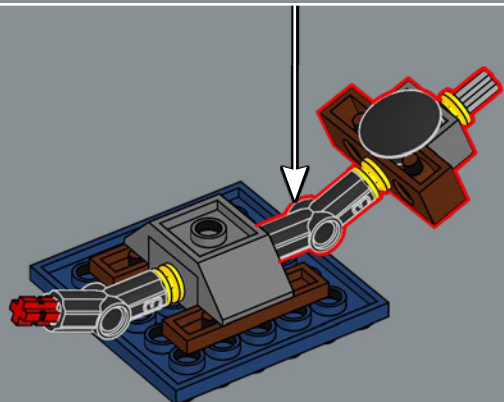
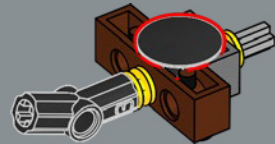

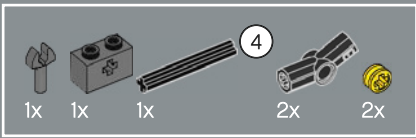

361

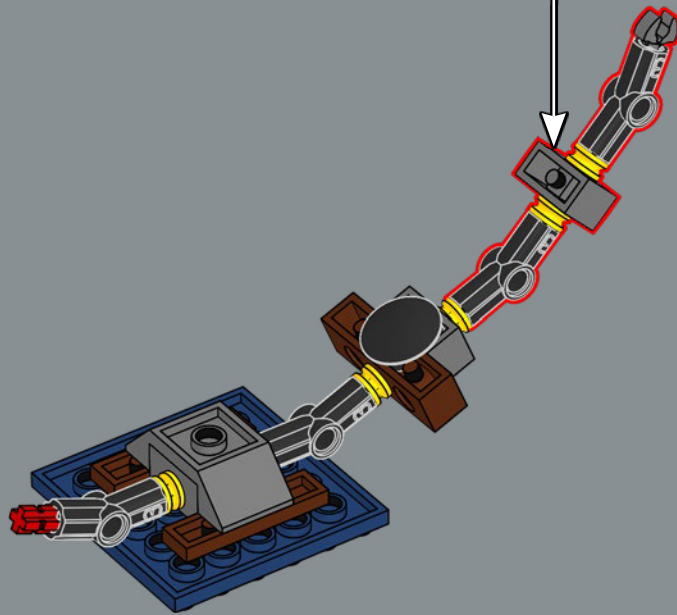
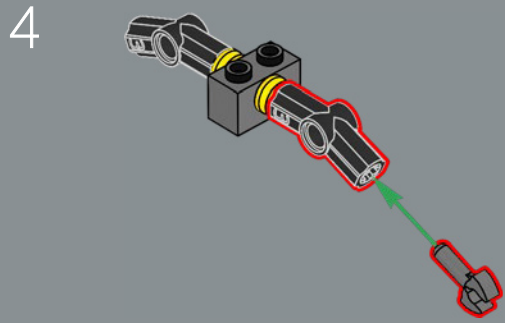
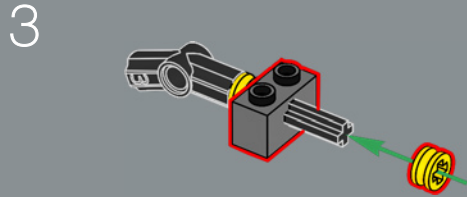
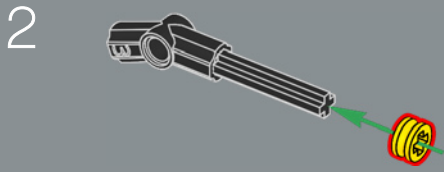
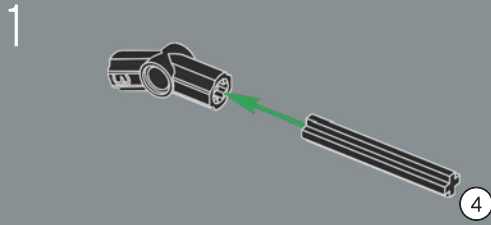

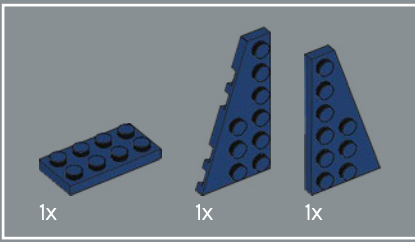

362

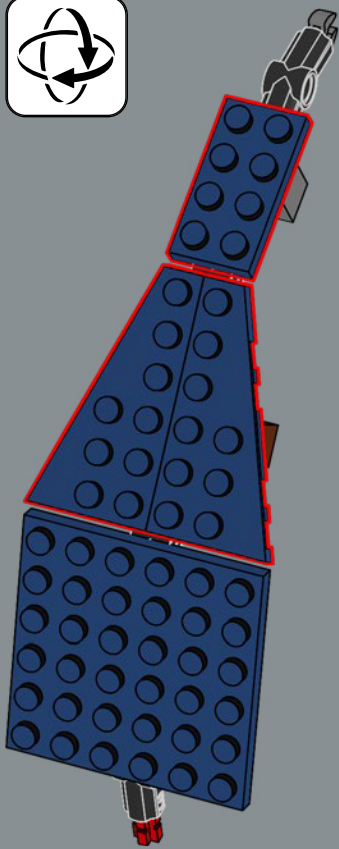

2x

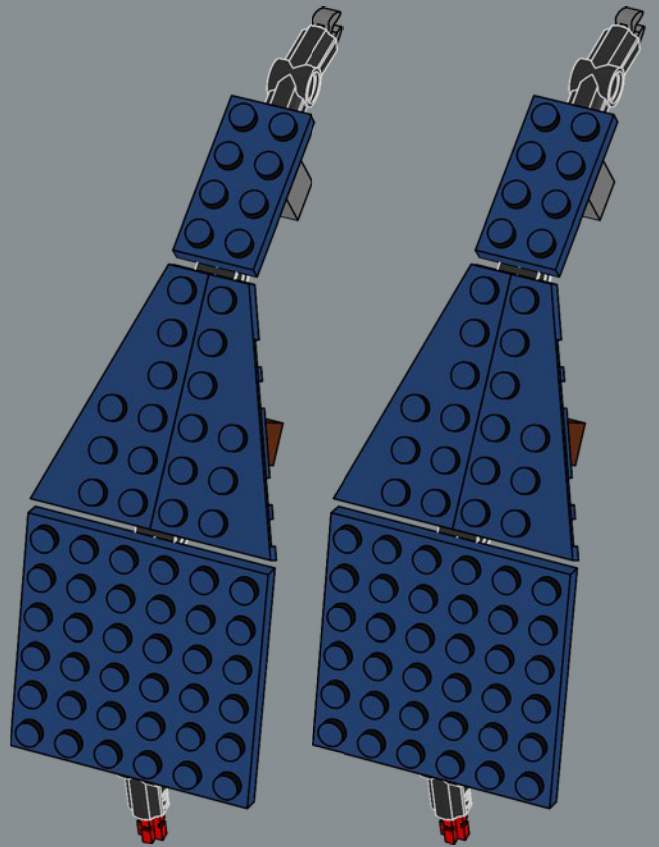

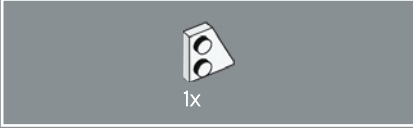
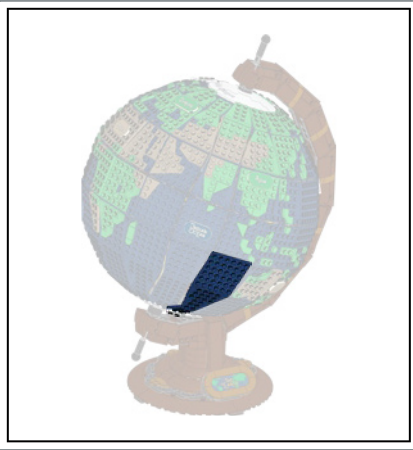

363

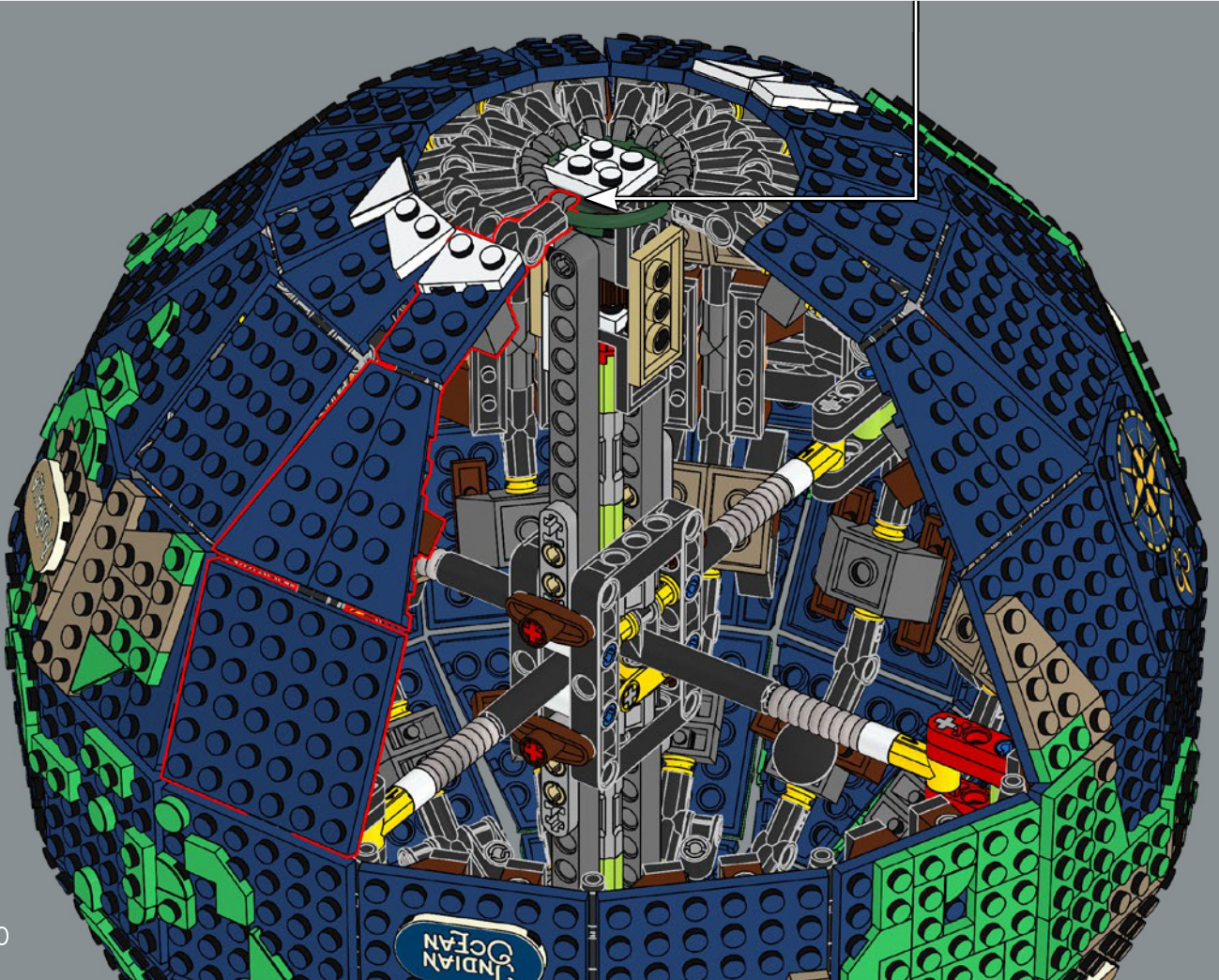
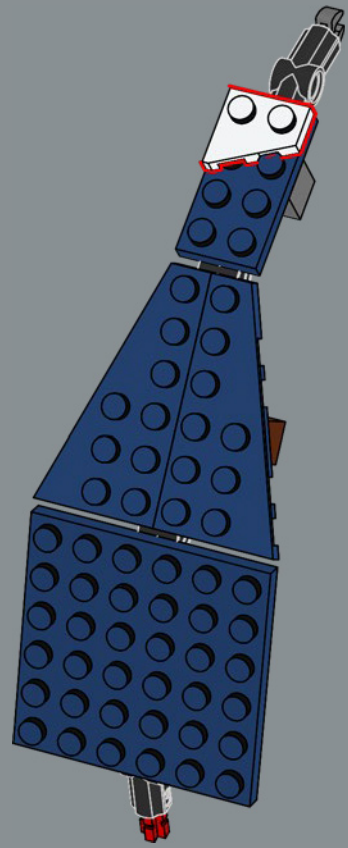

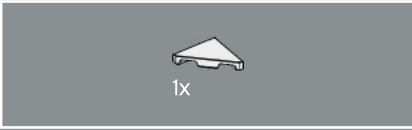

364

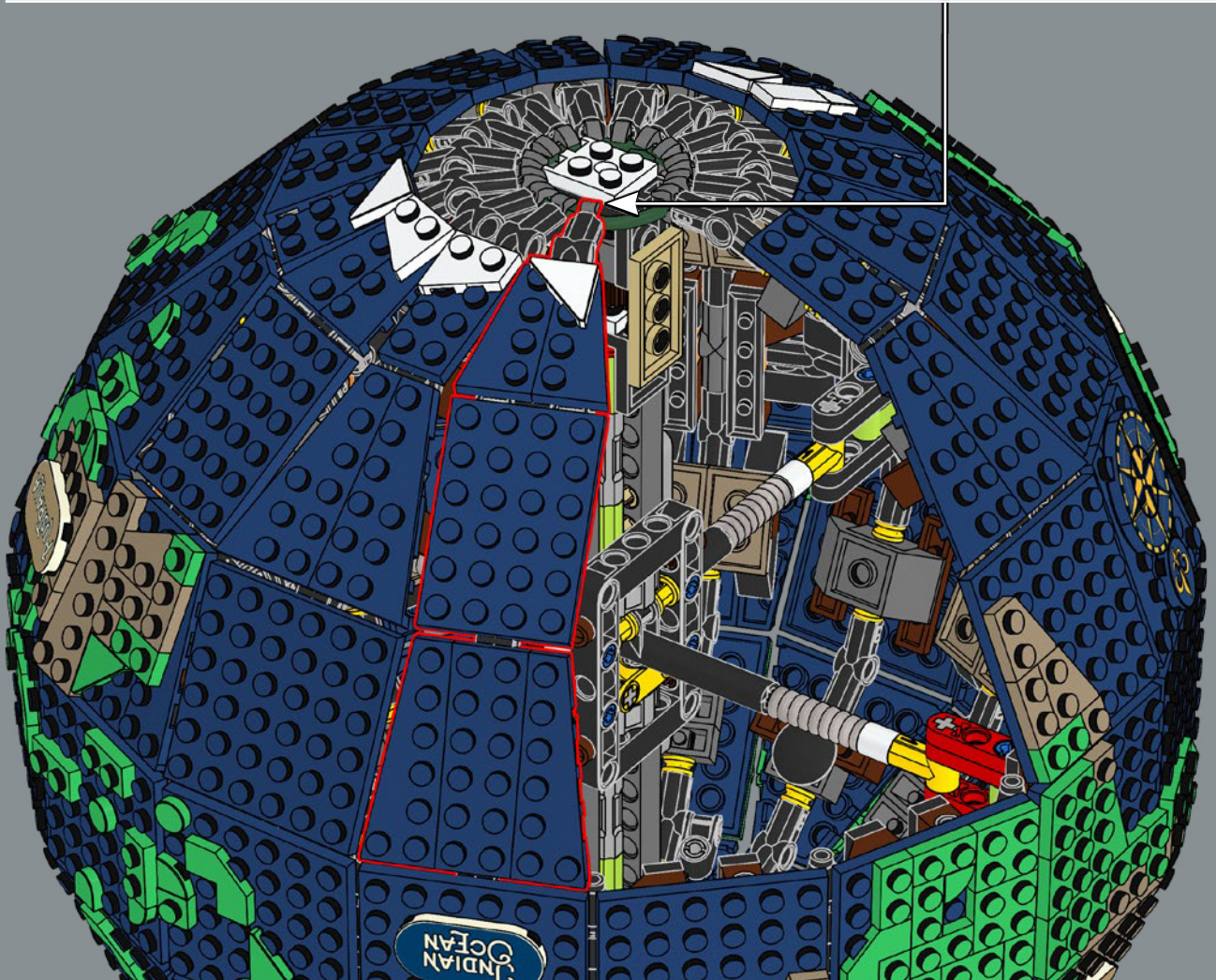
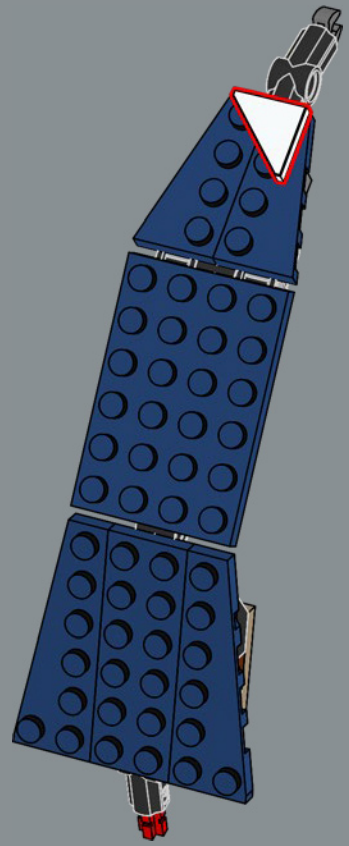

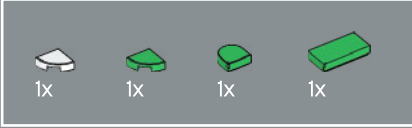

365

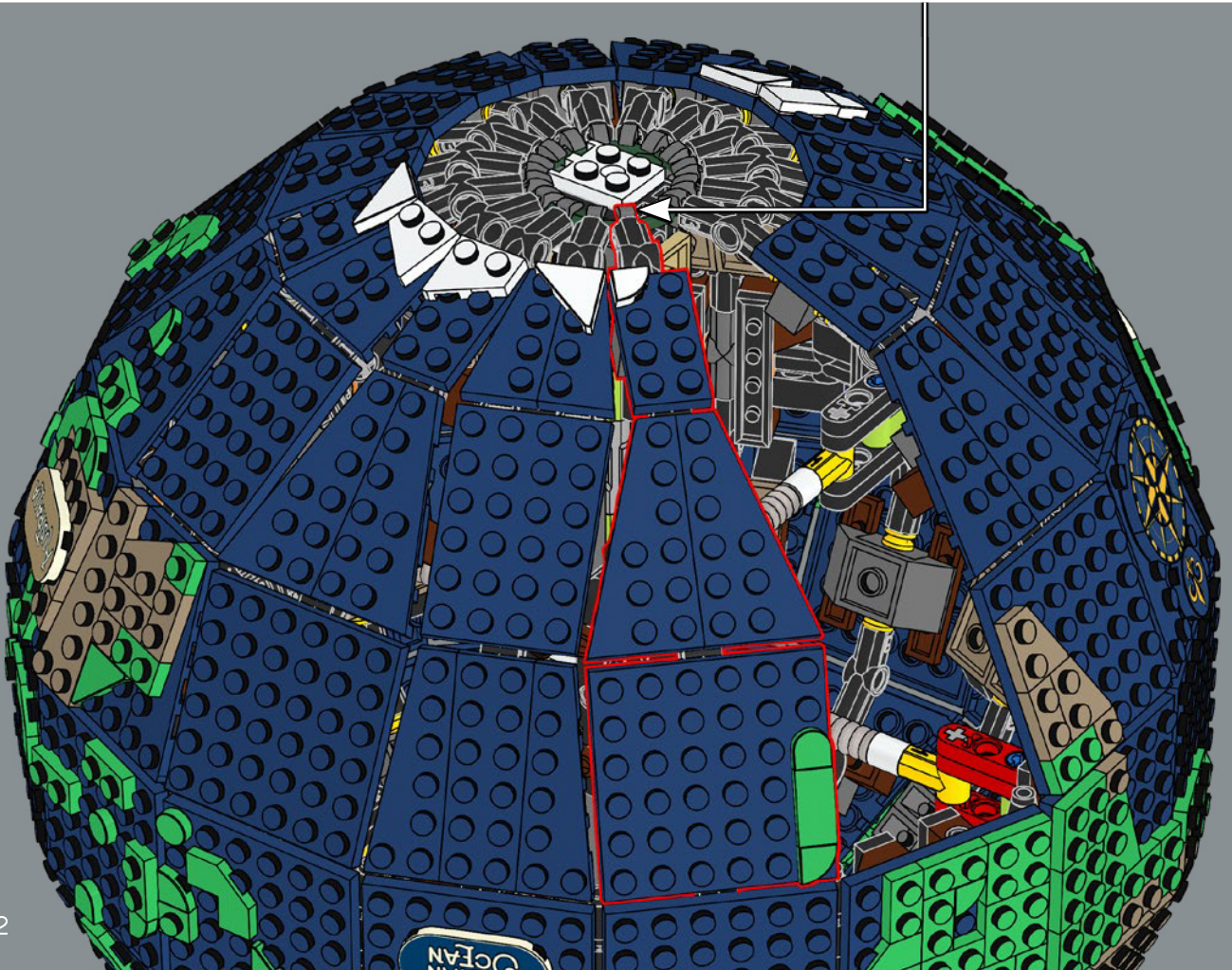
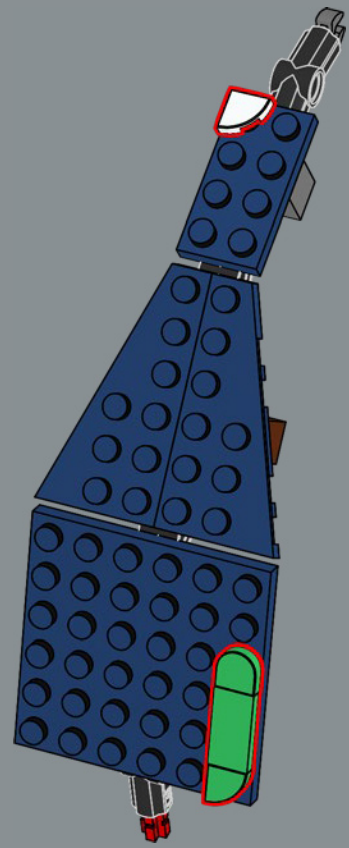

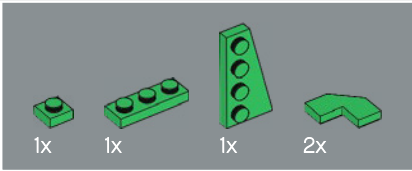

366

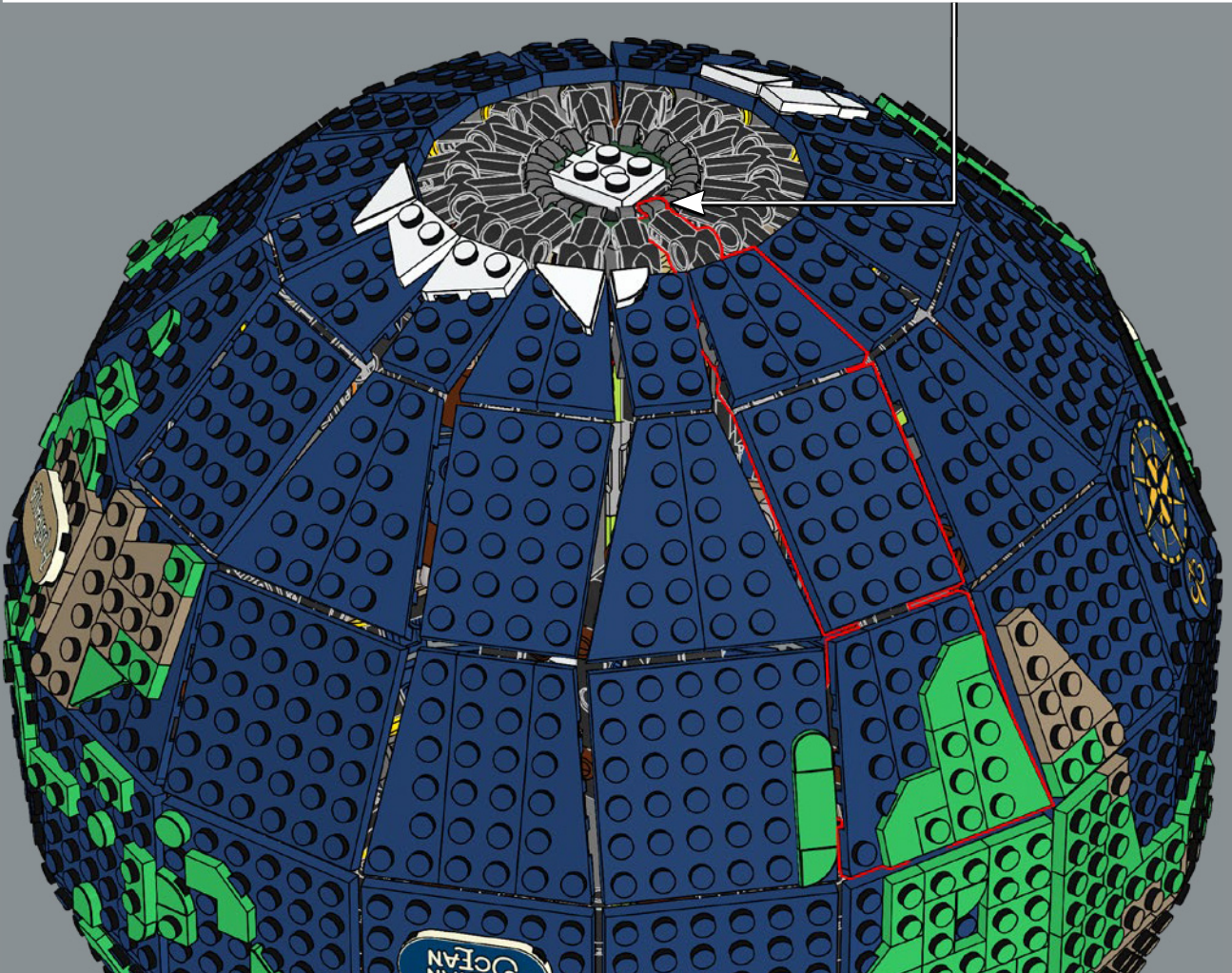
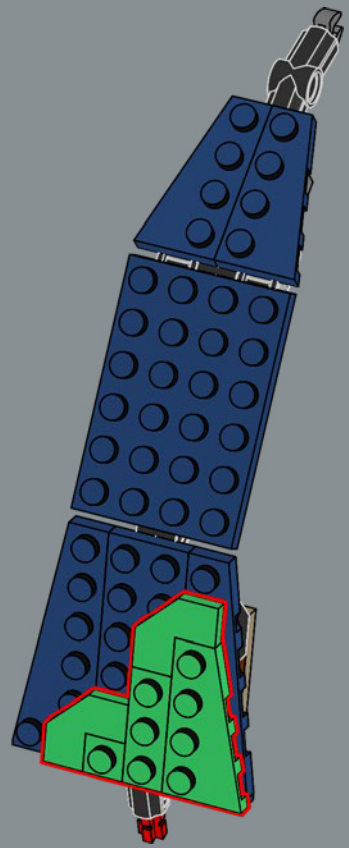

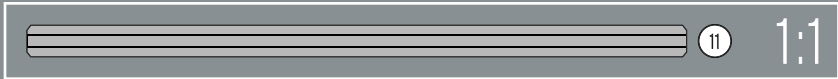
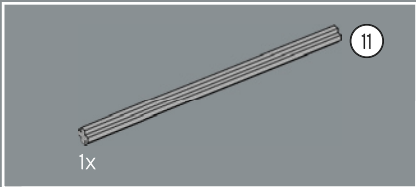
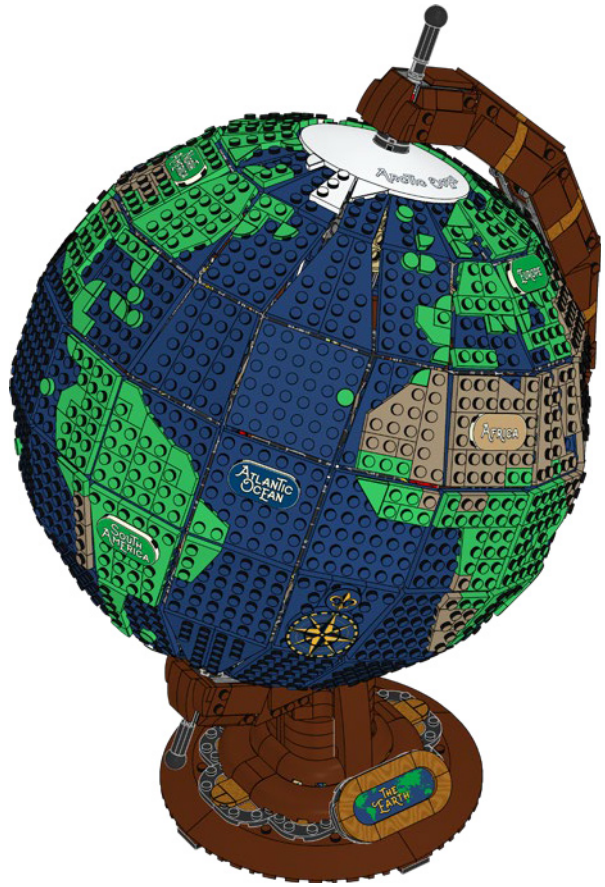

367

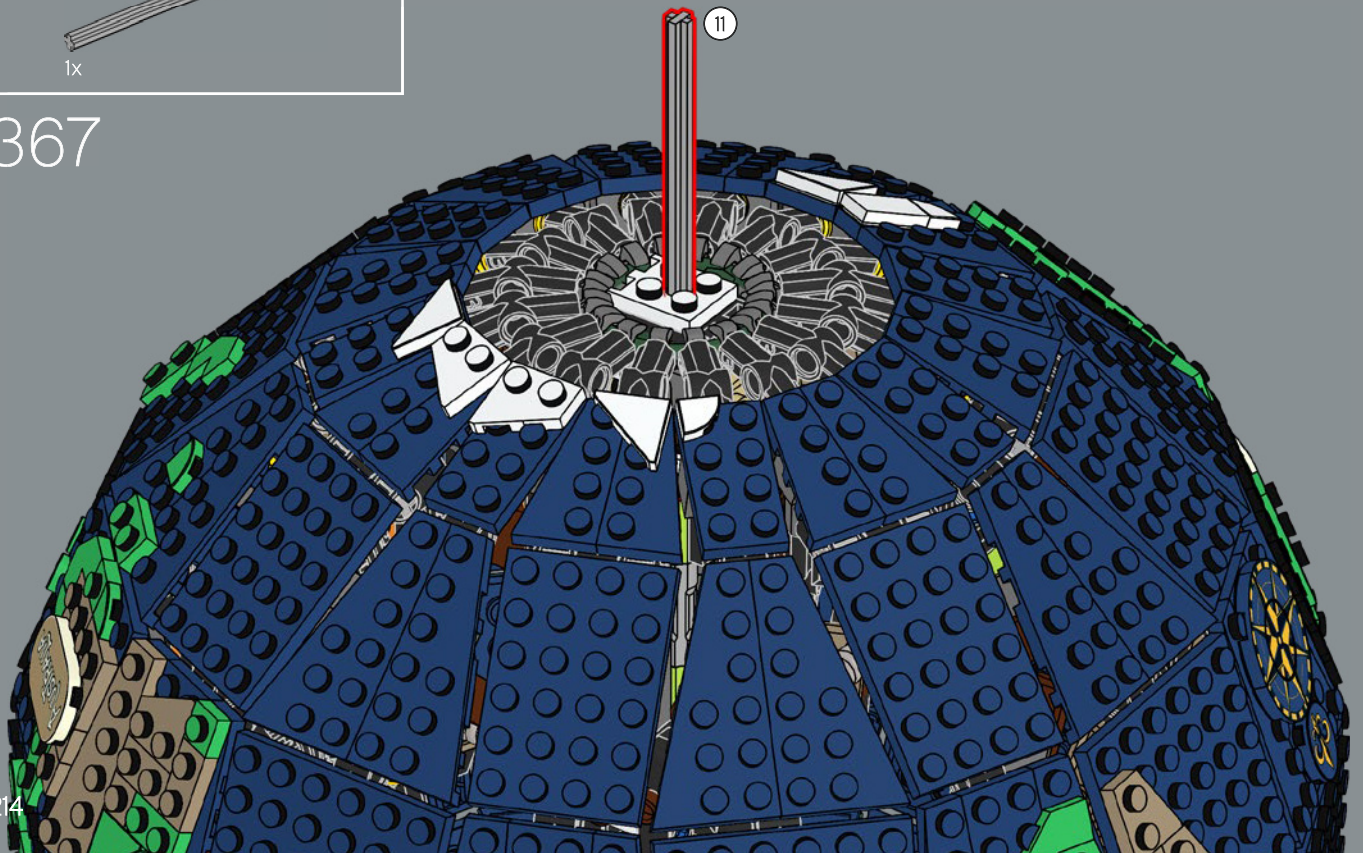

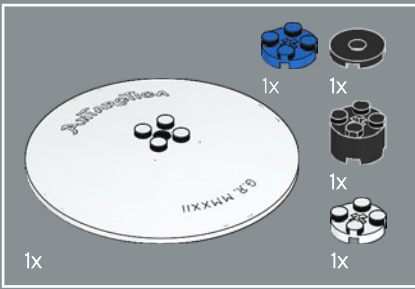

368

1



2

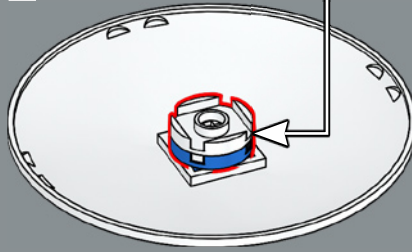

3

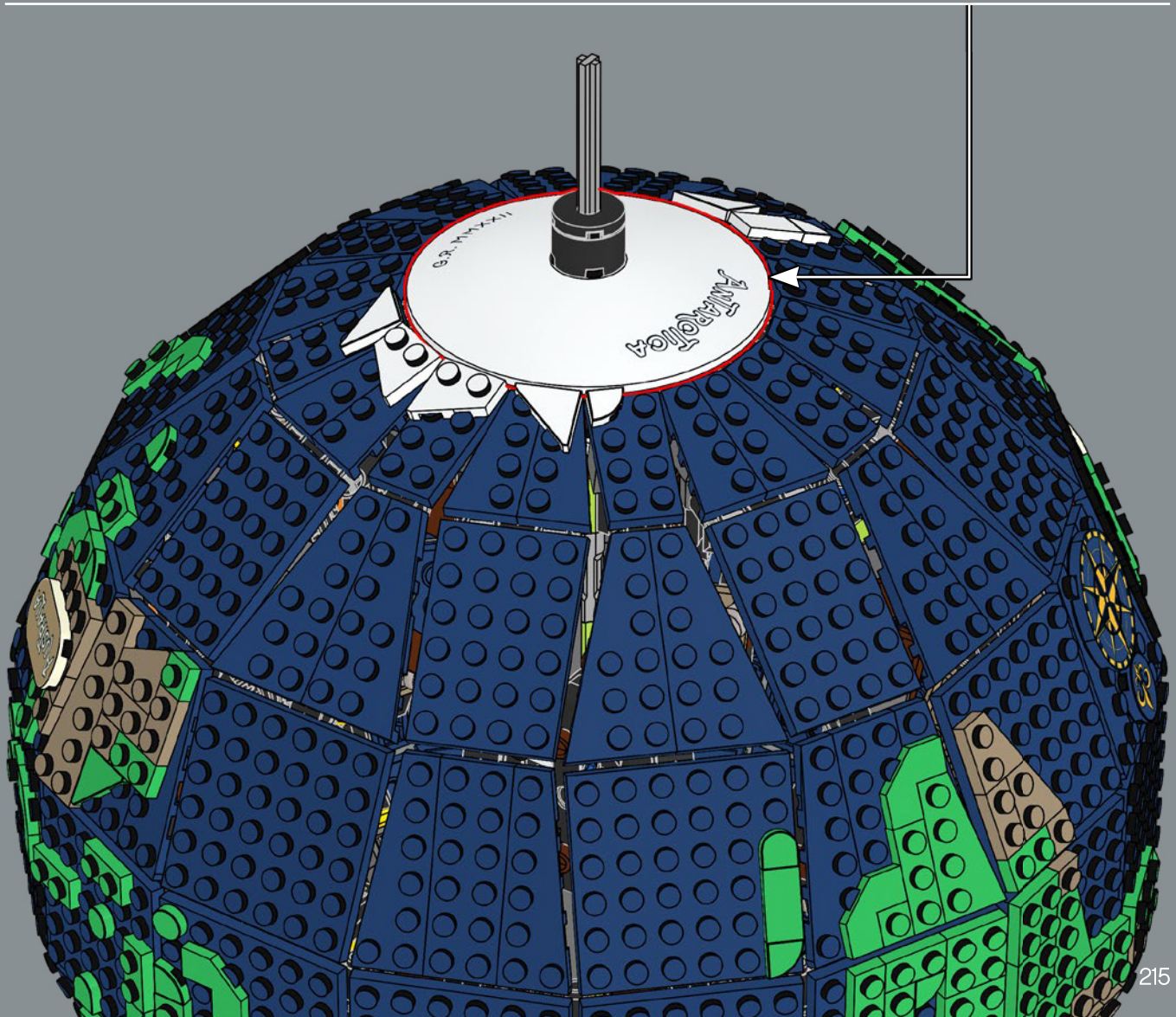
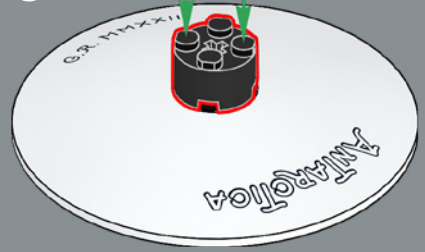

2x

369

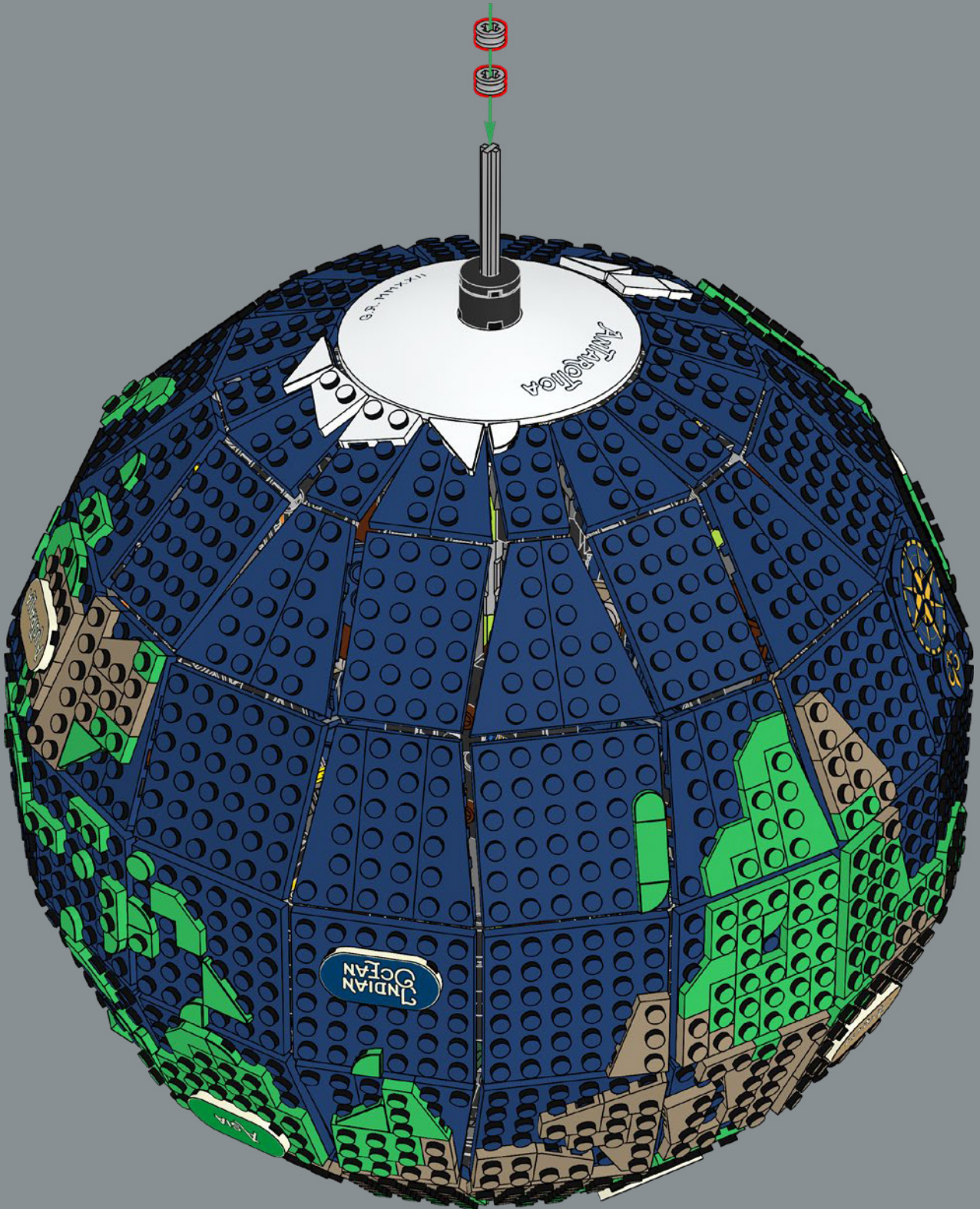

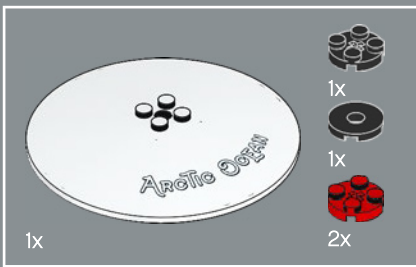

370

1



2

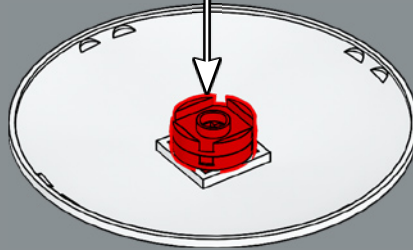

3

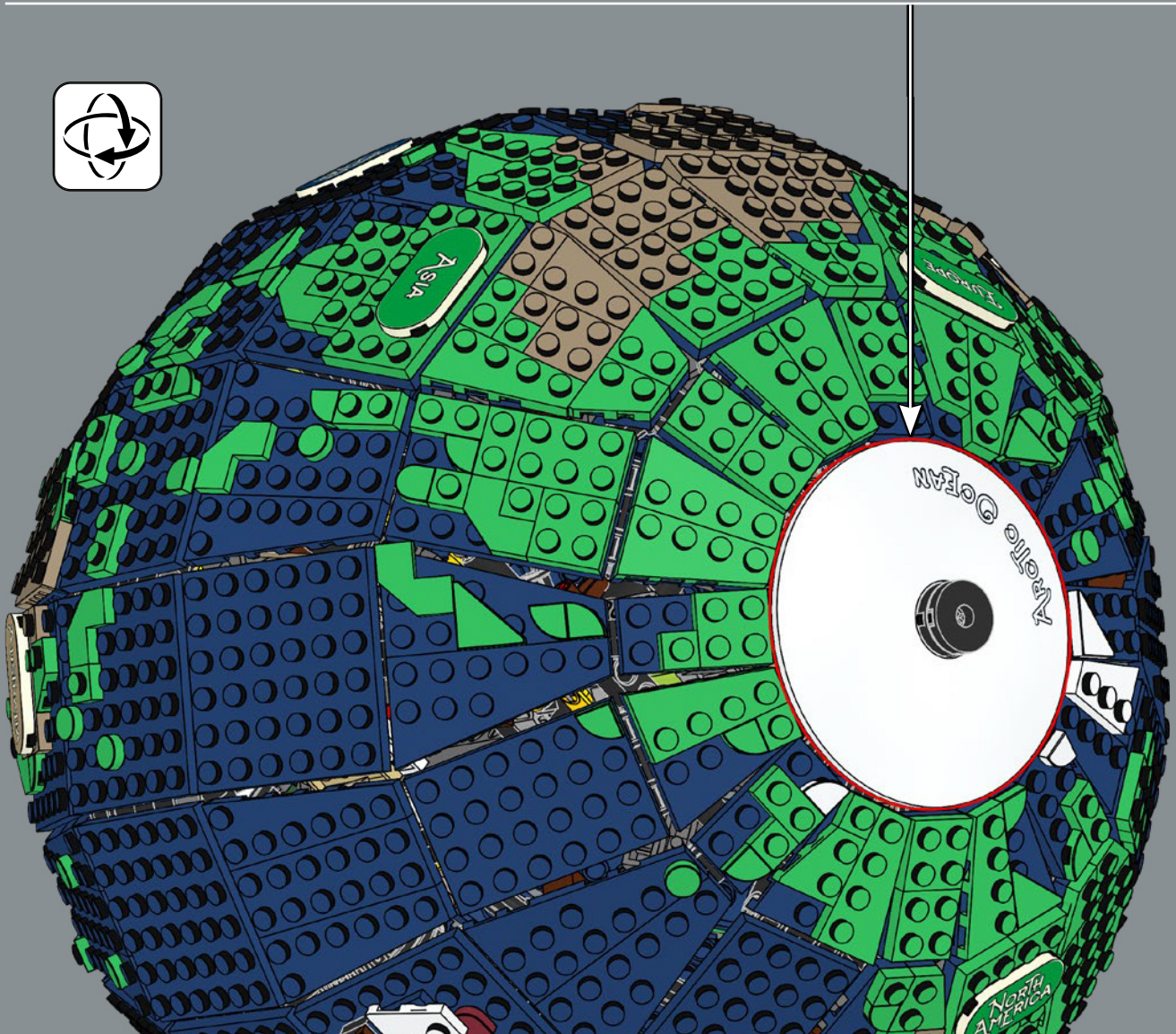
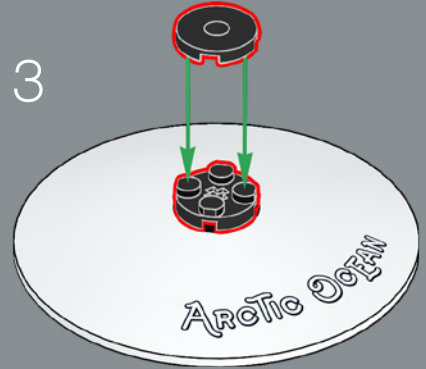

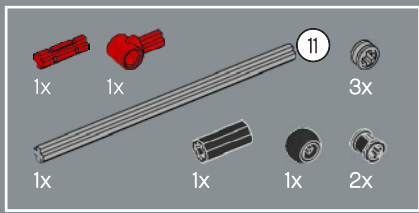

371

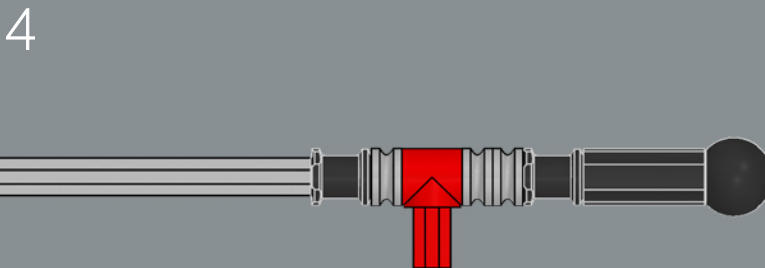
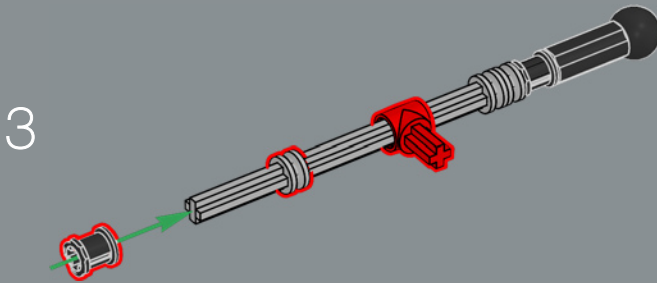
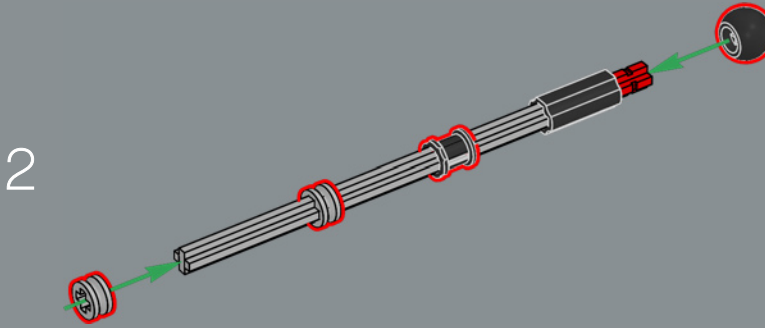
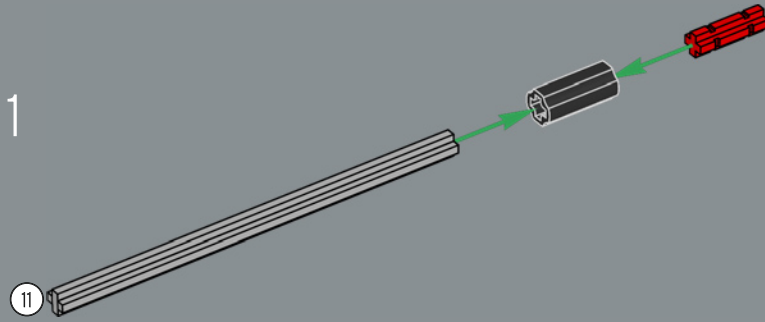

1:1

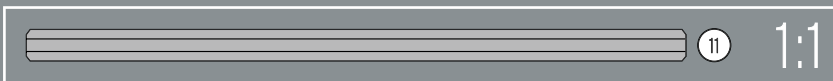

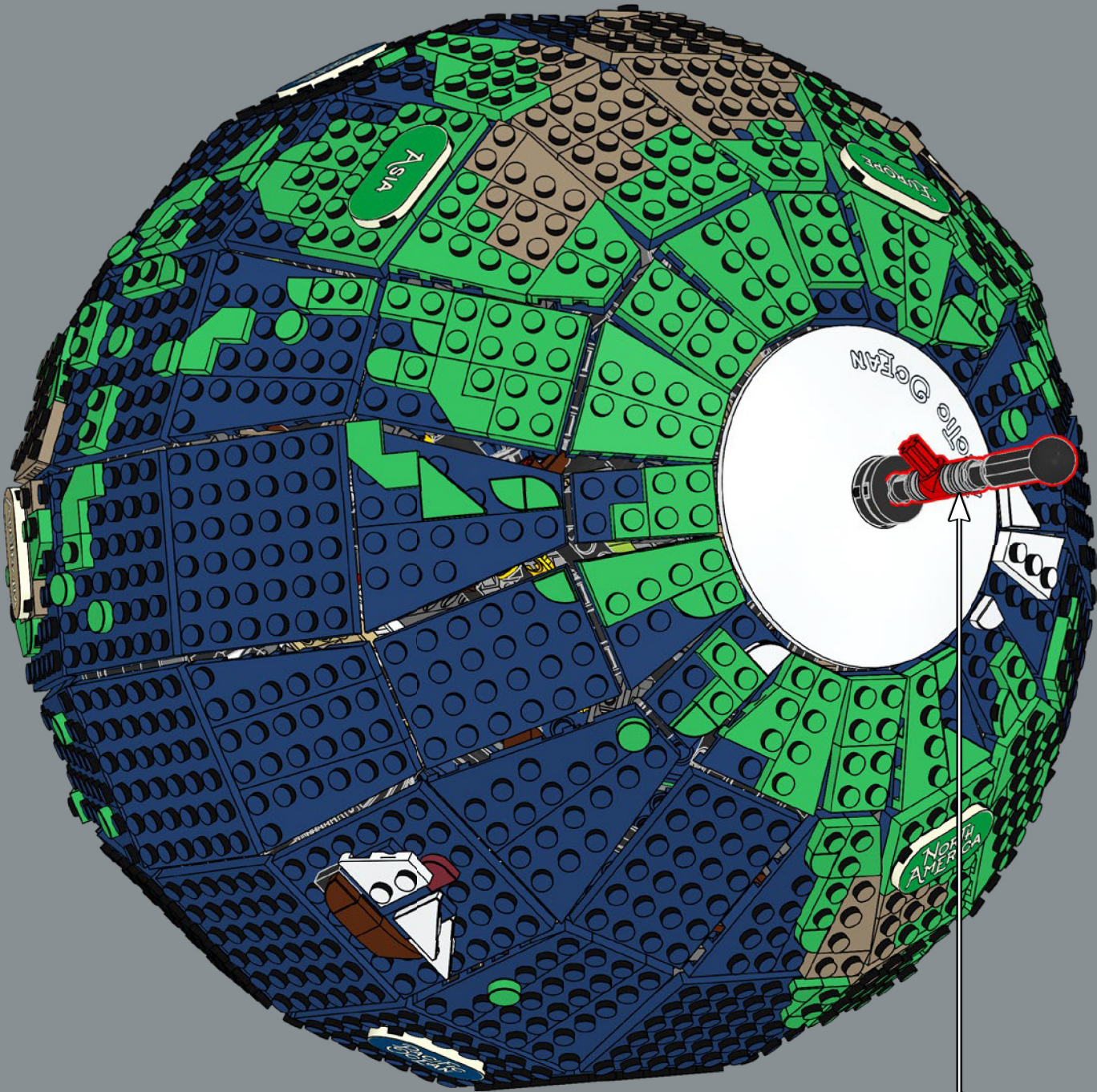

372

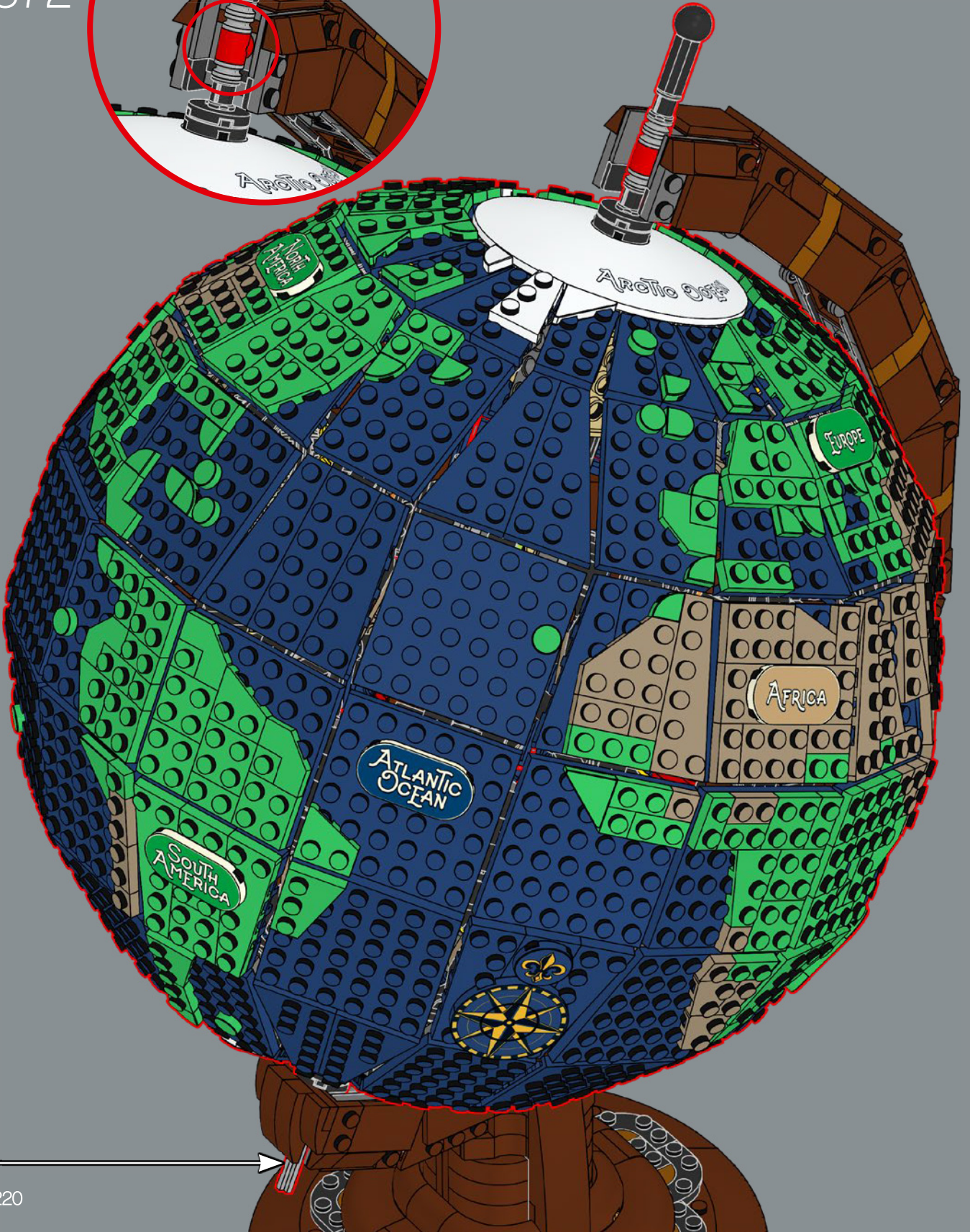
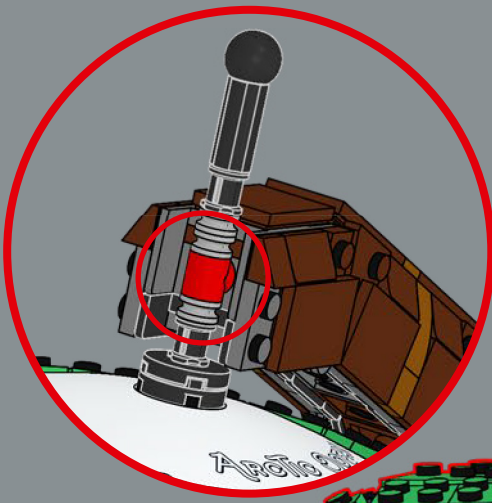



373

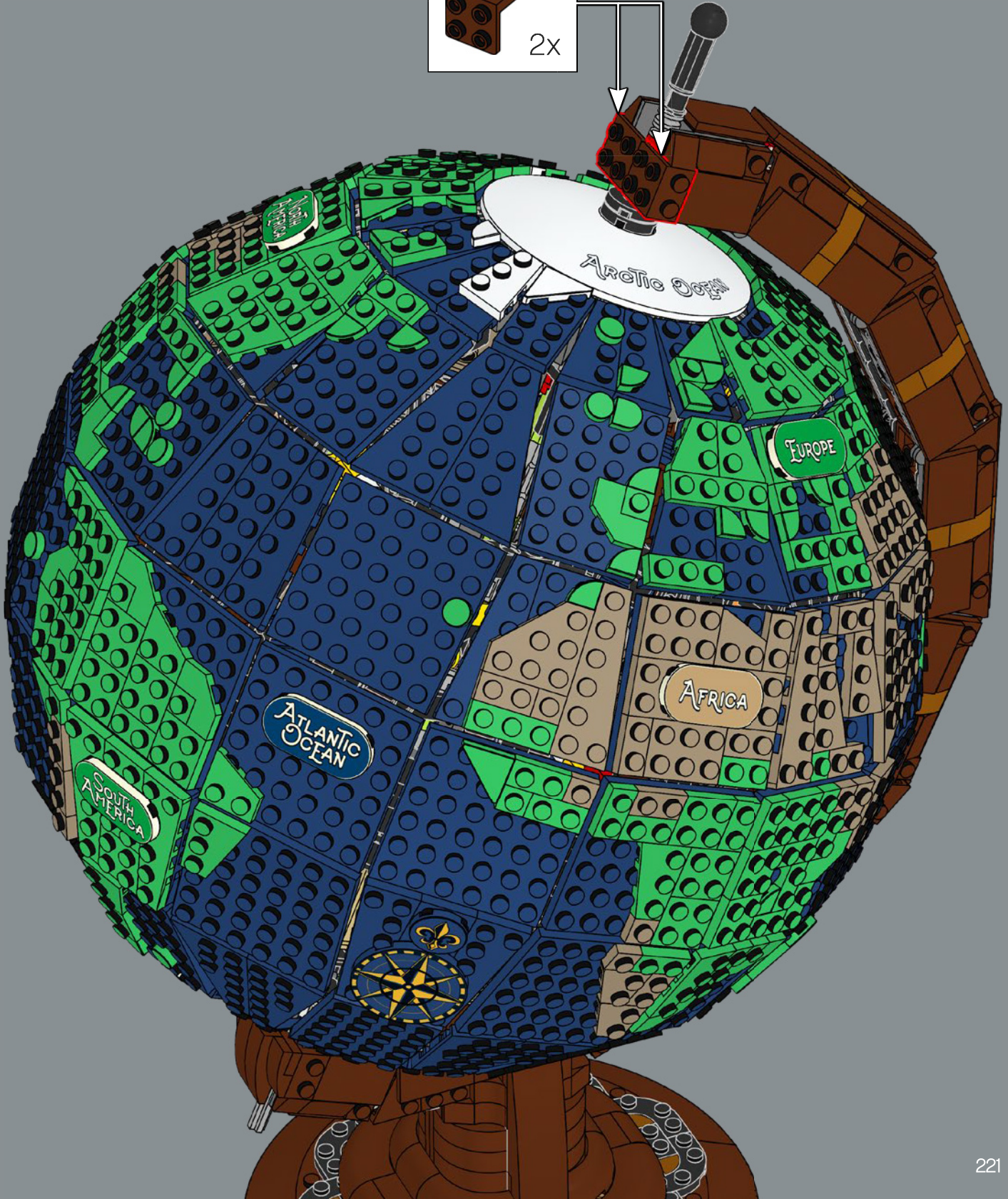
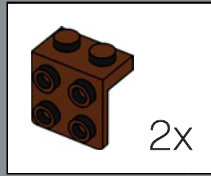

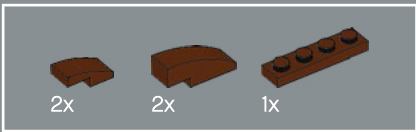

374

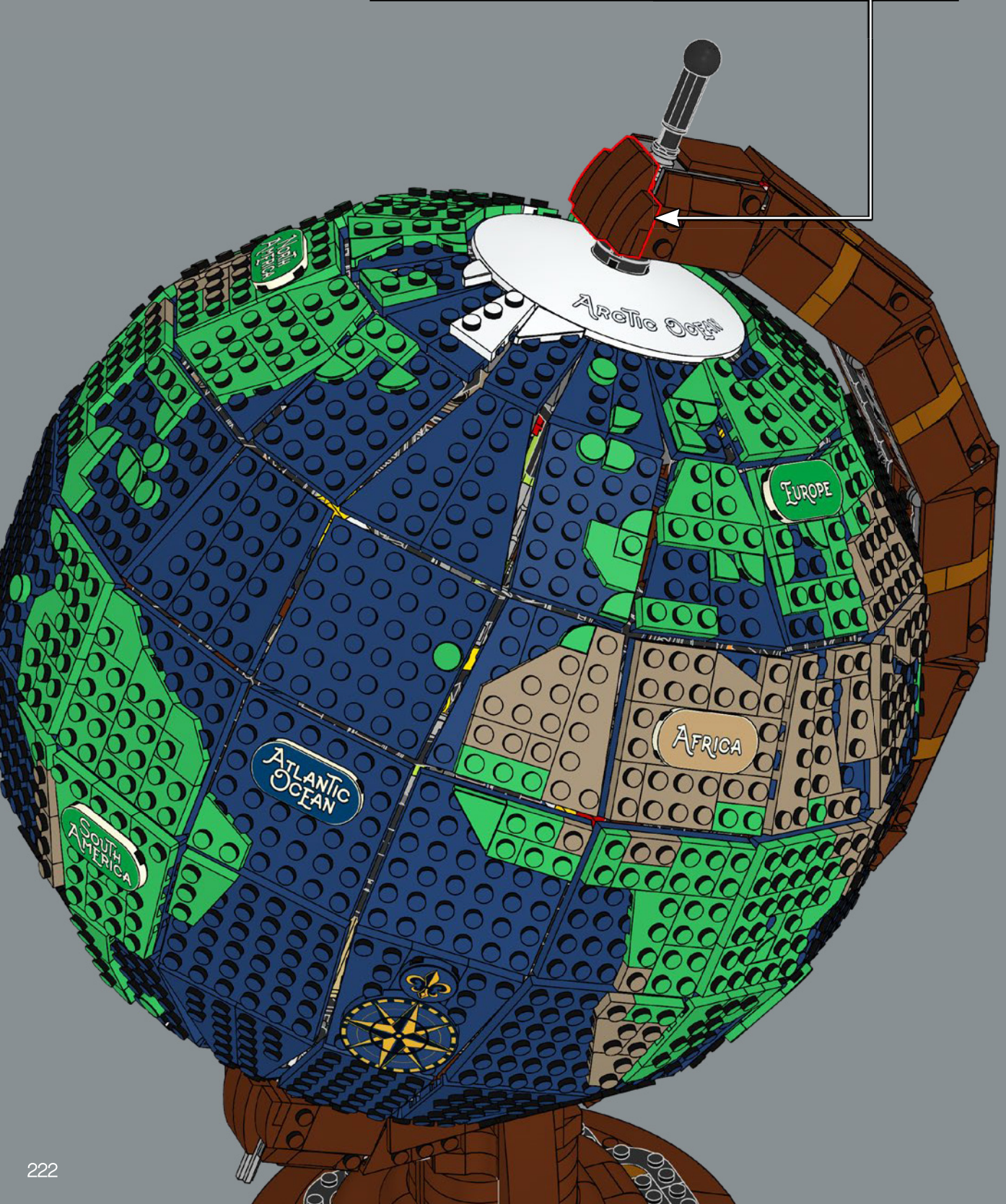
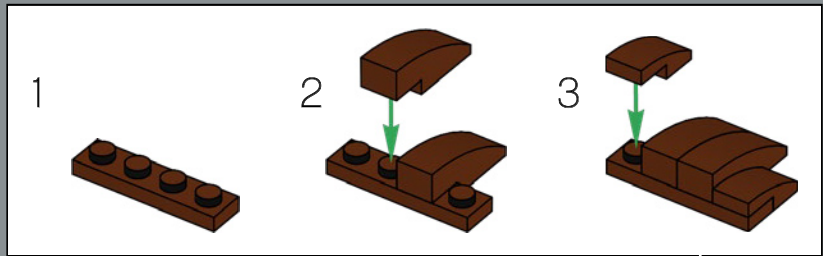

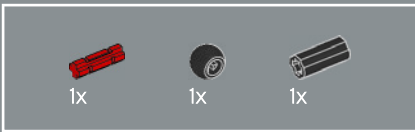

375

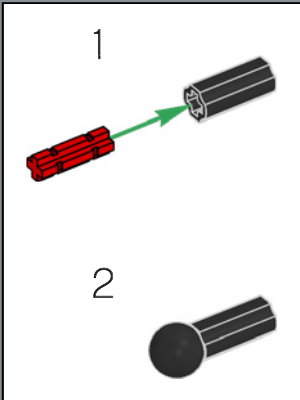
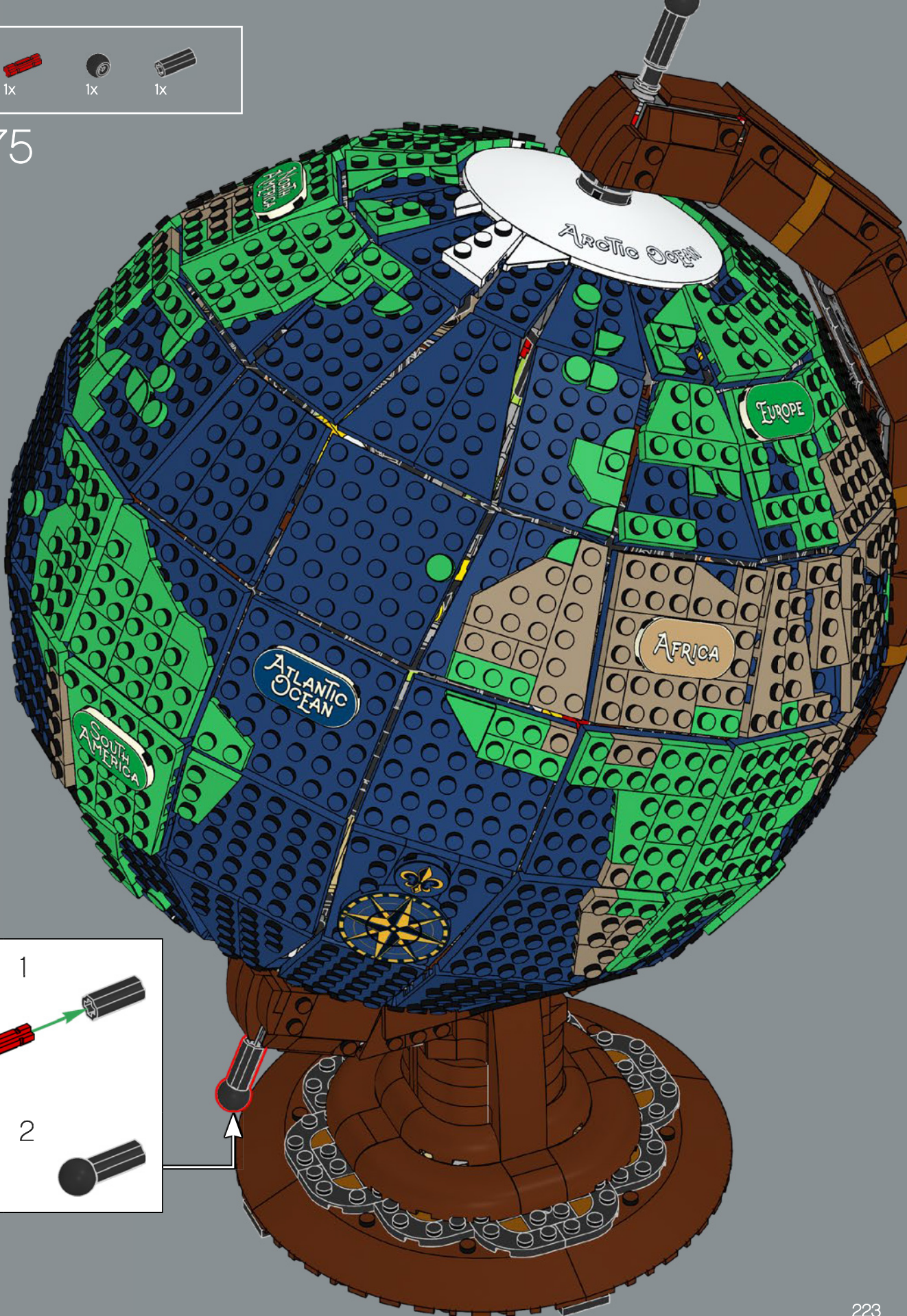

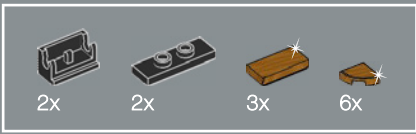

376

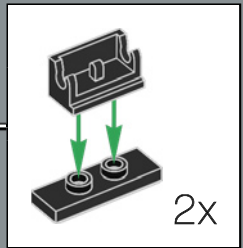
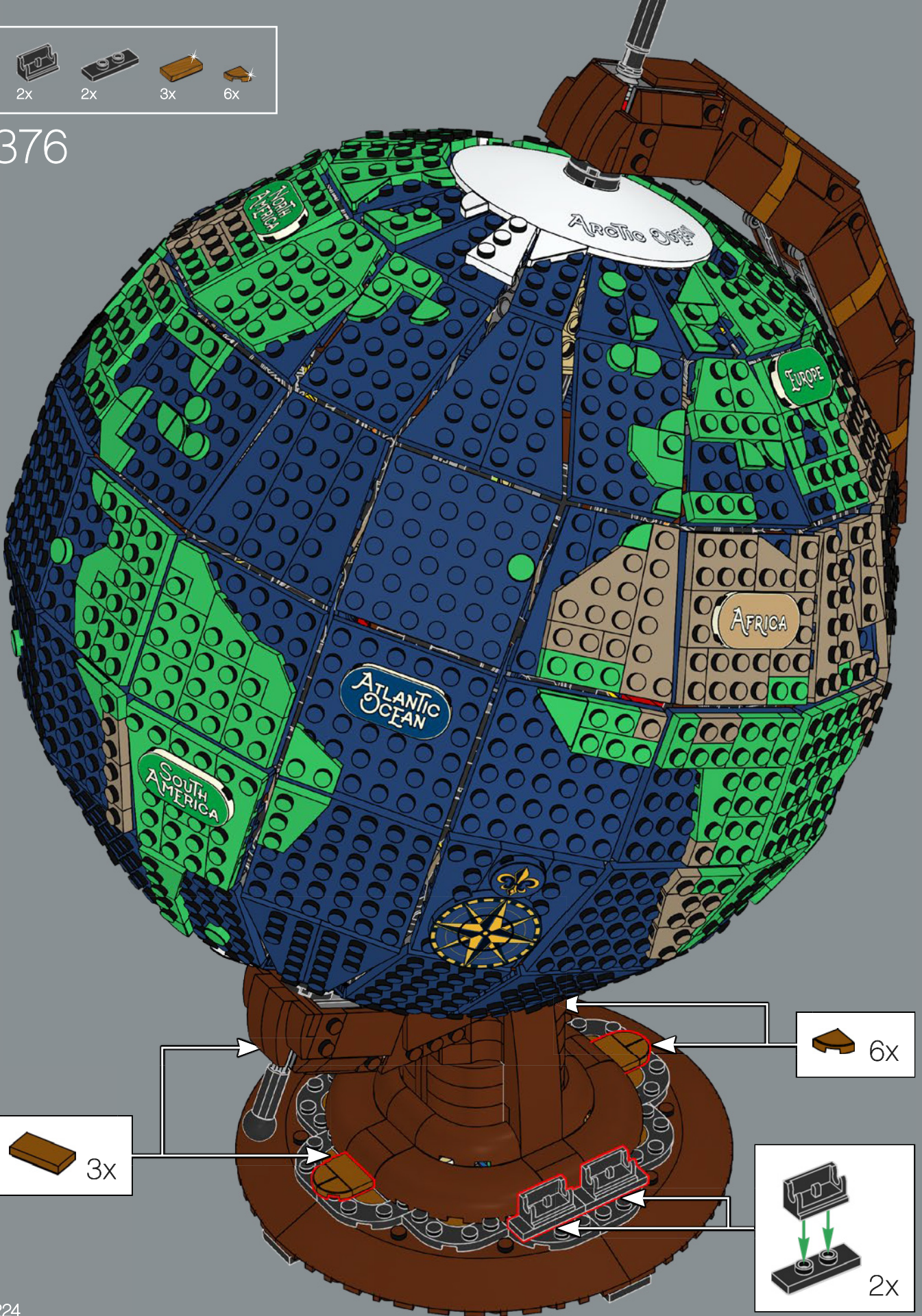

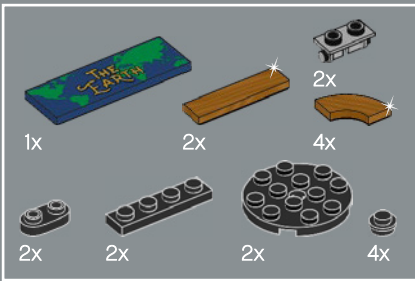

377

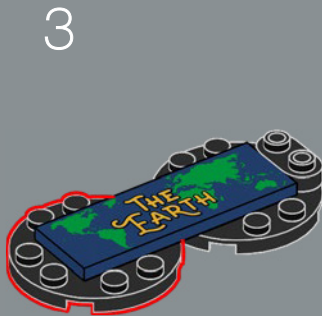
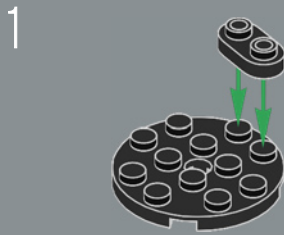

4



5



6

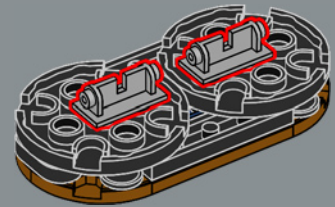

7

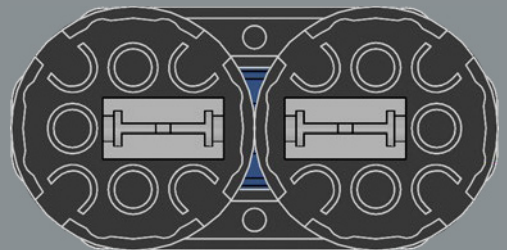

1:1

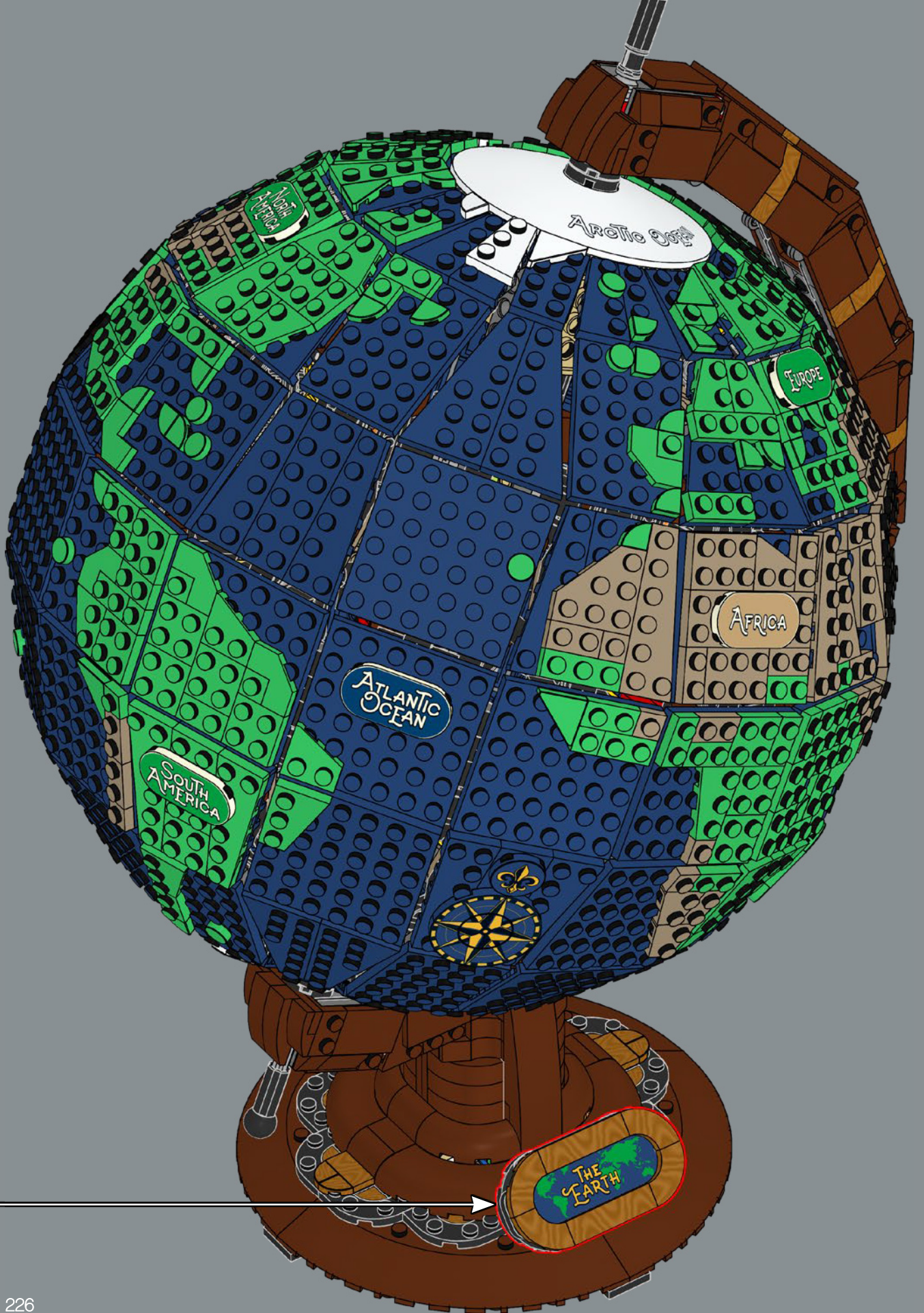



FEEDBACK AND WIN

FEEDBACK AND WIN

Your feedback will help shape the future development of this product series.

Please visit:

FEEDBACK UND GEWINNEN

Dein Feedback trägt zur Weiterentwicklung dieser Produktreihe bei.

Geh auf:

COMMENTEZ ET GAGNEZ

Vos commentaires nous aideront à concevoir les futurs produits de cette gamme.

Rendez-vous sur :

COMENTA Y GANA

Tu opinión nos ayudará a dar forma al desarrollo de esta serie de productos en el futuro.

Visita:

反馈有奖

您的反馈将有助于我们在今后改进本系列产品。

请访问：

[LEGO.com/productfeedback](https://www.lego.com/productfeedback)

By completing, you will automatically enter a drawing to win a LEGO® set.

Terms & Conditions apply.

Durch Ausfüllen nimmst du automatisch an der Verlosung eines LEGO® Preises teil.

Es gelten die Teilnahmebedingungen.

En envoyant vos commentaires, vous serez automatiquement inscrit(e) à un tirage au sort qui vous permettra de remporter un prix LEGO®.

Offre soumise à conditions.

Al contestar, participarás automáticamente en el sorteo y podrás ganar un set LEGO®.

Sujeto a Términos y Condiciones.

完成我们的反馈调查,即可自动进入抽奖环节,赢取乐高®套装。

适用《条款和条件》。



IDEAS

GATHER SUPPORT
OBTIENS DE L'APPUI
OBTÉN APOYOS

SHARE YOUR IDEA
PARTAGE TON IDÉE
COMPARTE TU IDEA

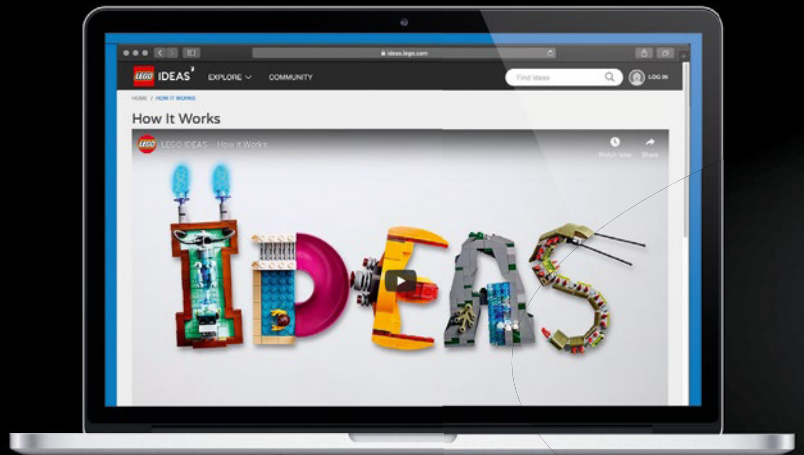
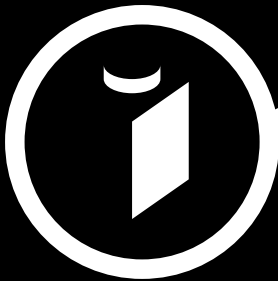
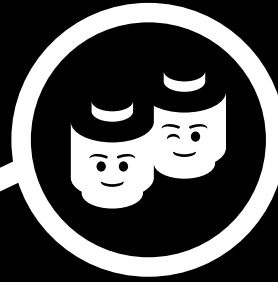

NEW LEGO® PRODUCT
NOUVEAU PRODUIT LEGO®
NUEVO PRODUCTO LEGO®

LEGO® REVIEW
EXAMEN LEGO®
REVISIÓN DE LEGO®



ideas.LEGO.com

© 20th Century Studios.

FENDER, STRATOCASTER, ESQUIRE, TELECASTER, PRECISION BASS, PRINCETON, and the distinctive headstock shapes commonly found on Fender guitars are trademarks of Fender Musical Instruments Corporation and/or its affiliates.

©SEGA. All rights reserved. SEGA is registered in the U.S. Patent and Trademark Office. SEGA and SONIC THE HEDGEHOG are either registered trademarks or trademarks of SEGA CORPORATION.

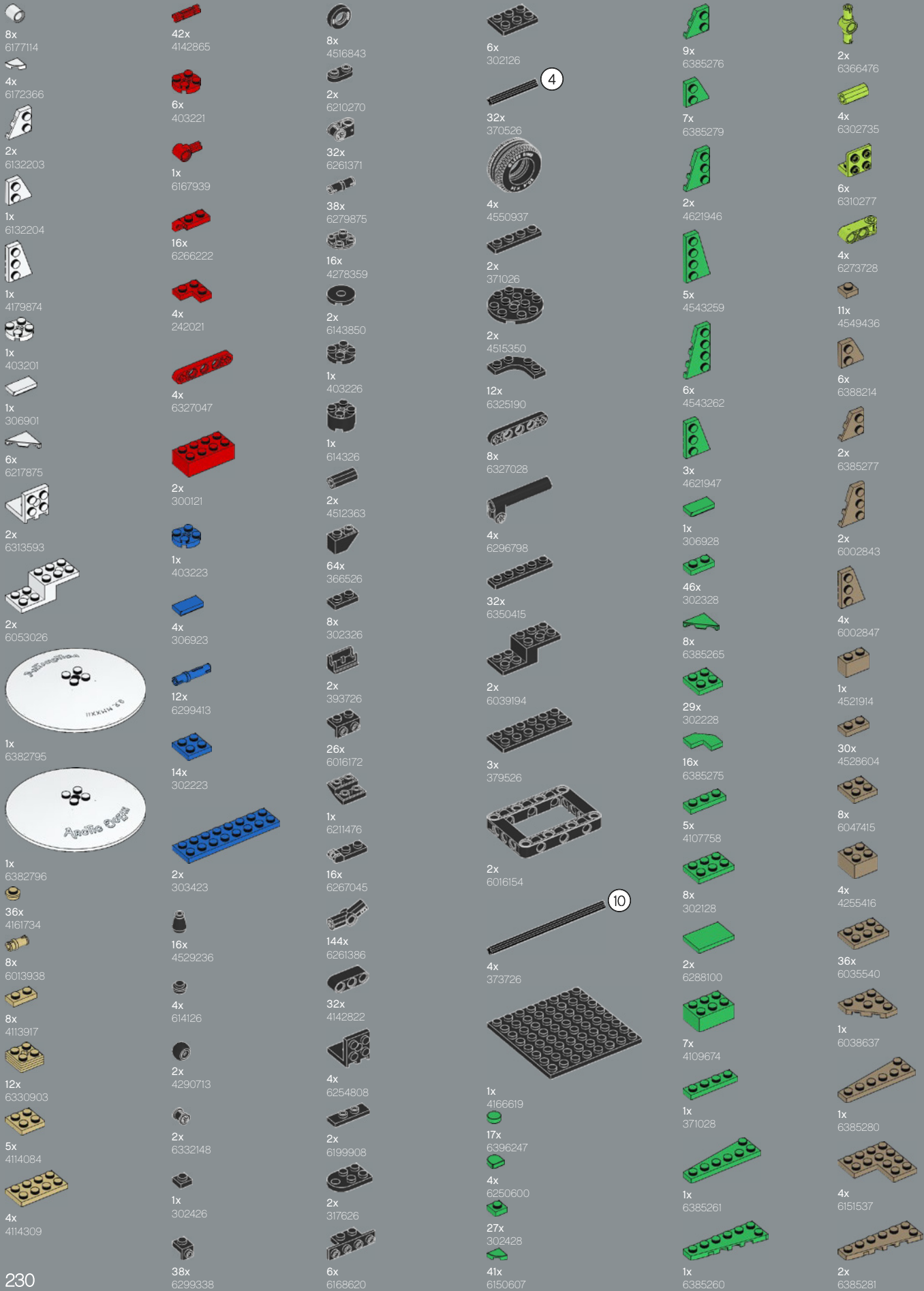

16x 4529954
16x 4502091
1x 6391278
1x 6382799
1x 6092588
16x 6253880
16x 6253881
1x 6389696
4x 6382797
16x 4667595
16x 6385259
16x 6385253
1x 6382794
16x 6097420
16x 6037887
32x 6106692

1x 6322997
8x 4504376
1x 4211288
32x 4620075
1x 6149677
8x 6385262
8x 6385263
1x 6290396
4x 6385278
28x 6035291
2x 6036503
6x 6311210
8x 6365885
41x 4211150
2x 4211151
4x 6069984
4x 6117976
6x 6174856
4x 6323704
12x 4216695
6x 6196221

1x 4211210
32x 4211221
16x 4211257
2x 6146301
16x 6299939
4x 4211152
4x 6325975
4x 6385251
40x 6311441
2x 4211189
32x 4267994
34x 4211190
6x 4579690
1x 4211247
4x 6385252
2x 6309010
5x 6271165
32x 4211483

32x 6278155
42x 6336390
129x 6178919
28x 6117972
4x 4211094
12x 6271876
2x 4211133
4x 6118932
21x 4211043
2x 4211024
16x 6083620
16x 6102774
16x 4211076
8x 4211056
2x 4210678
4x 4603472

2x 4211470
28x 4211815
2x 6186129
3x 6273212
2x 6254807
2x 6347992
4x 6331574
4x 4211395
80x 4211639
2x 6178172
2x 6329283
1x 6254100

12x 6264167
18x 6251591
12x 6294532
9x 6265247
4x 6294524
2x 6332155
32x 6339309
15x 4125278
192x 6271167
4x 6329889
4x 6109681
4x 6276974
4x 6371963

8x 4538126
2x 6313599
4x 6116017
Pacific Fleet
1x 6392551
Pacific Fleet
1x 6392553
1x 6350033
1x 6350034
1x 6350039
1x 6361434
1x 6361435
1x 6361436
1x 6361437

Customer Service
Kundenservice
Service Consommateurs
Servicio Al Consumidor
LEGO.com/service or dial



: 00800 5346 5555
: 1-800-422-5346



