



21061





LEGO.com/sustainable-packaging



FR
DONNEZ
OU
RECYCLEZ



ASSOCIATION

OU



MAGASIN

OU



DÉCHÈTERIE

Adresses sur quefairedemesdechets.fr



BUILDER



Apple and the Apple logo are trademarks of Apple Inc., registered in the U.S. and other countries and regions. App Store is a service mark of Apple Inc. Google Play and the Google Play logo are trademarks of Google LLC. Tencent and the Tencent logo are trademarks of Tencent Inc.

LEGO.com/devicecheck



LEGO® Builder



巴黎圣母院

☁ “很难想象没有雄伟庄严的巴黎圣母院的情形。几个世纪以来，这座壮观的地标建筑经受住了风雨、革命和毁灭性破坏的洗礼，依然是巴黎最受欢迎的旅游景点之一。当你看到它无限的辉煌时，可能会想知道建筑师、石匠和建筑工人是如何创造出这样一座历史建筑的。它从近 900 年前开始动工，建造过程持续几个世纪。受到这些能工巧匠们的精妙技术的启发，我们着手将这座宏伟的建筑及其复杂的细节转化'成一款乐高®模型。”

“这些说明将引导你完成拼搭过程，每块积木的位置都经过精心考量，以与原始大教堂的特定建筑元素相对应。每完成一个积木袋，都会看到一个对应于这座大教堂建造过程中特定时间点（1163 年到今天）的模型。”

Rok Žgalin Kobe, 乐高®高级设计师

1163-1182 年

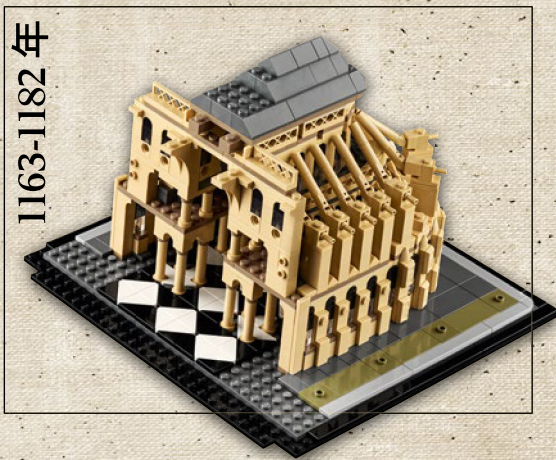

1163-1182 年：大教堂的东侧首先完工，具备了齐全的功能，其余部分在继续建设中。

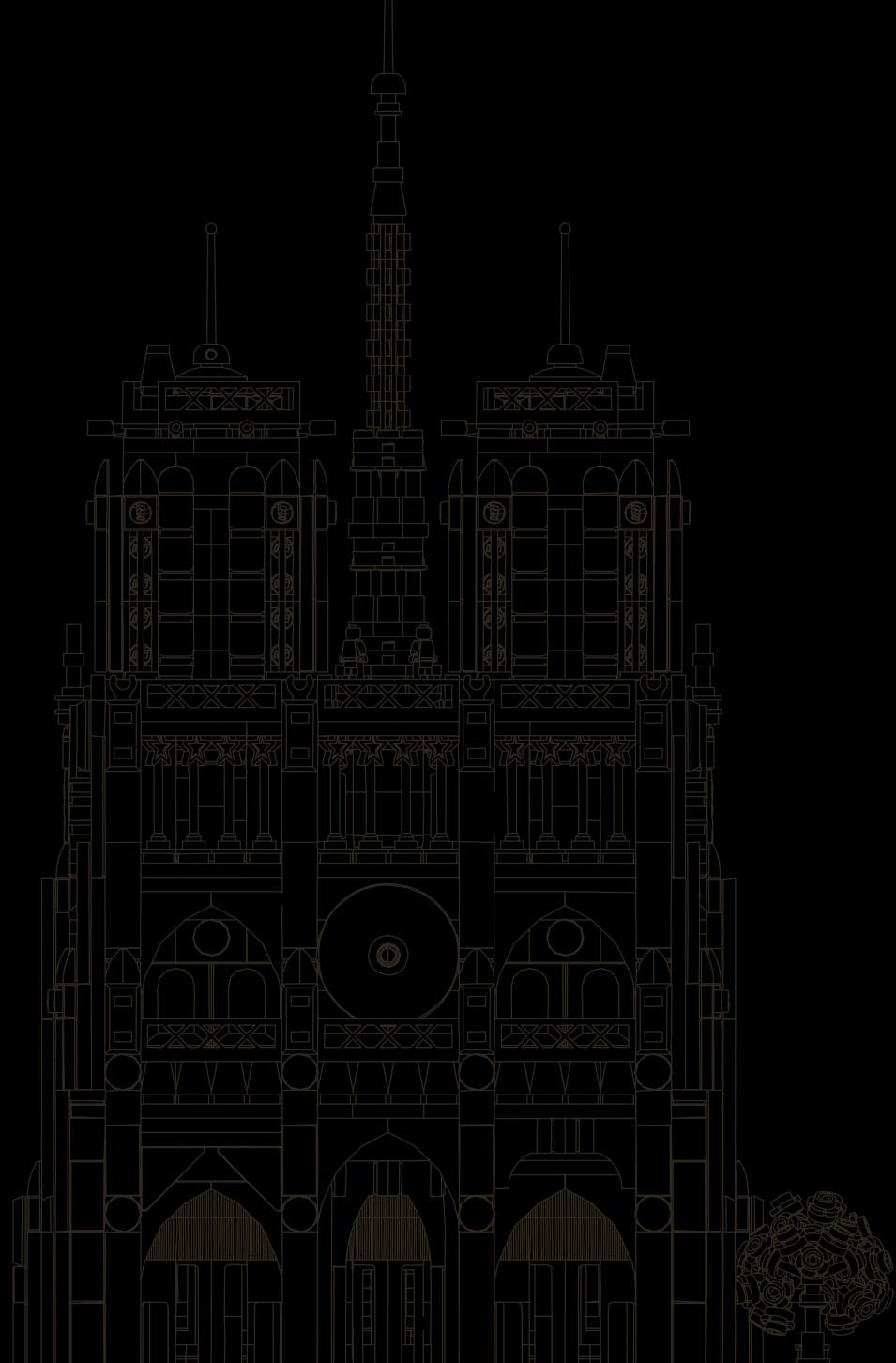

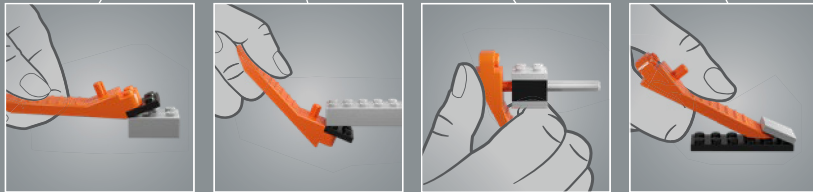
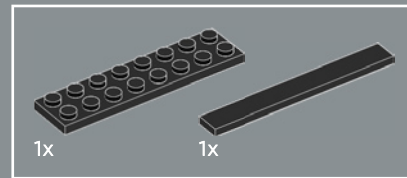
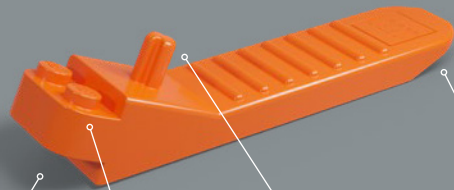

1

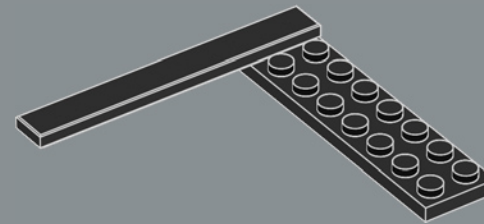

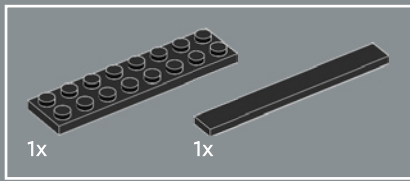

2

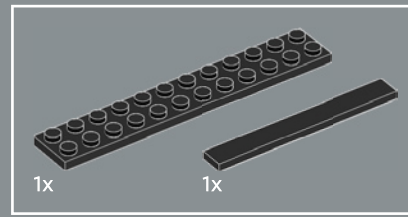
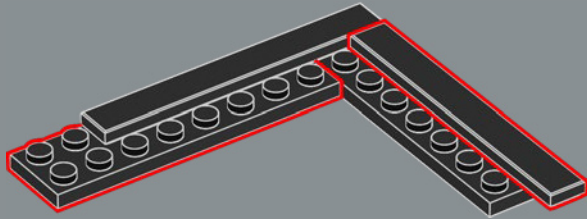

3

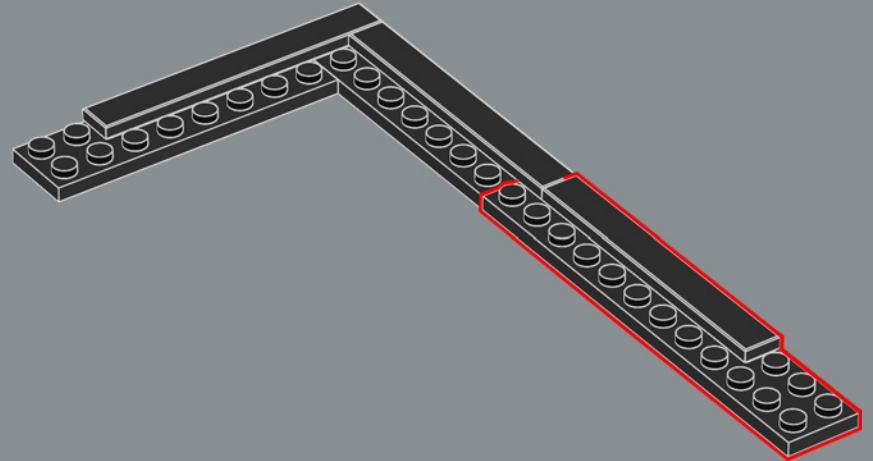

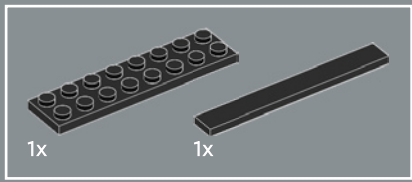

4

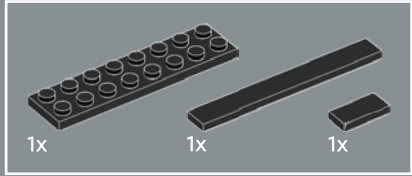
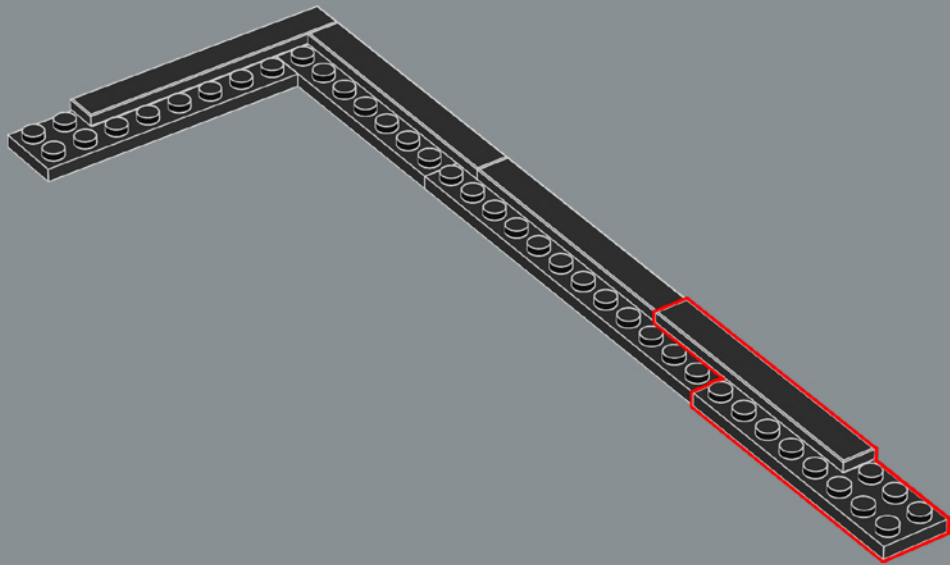

5

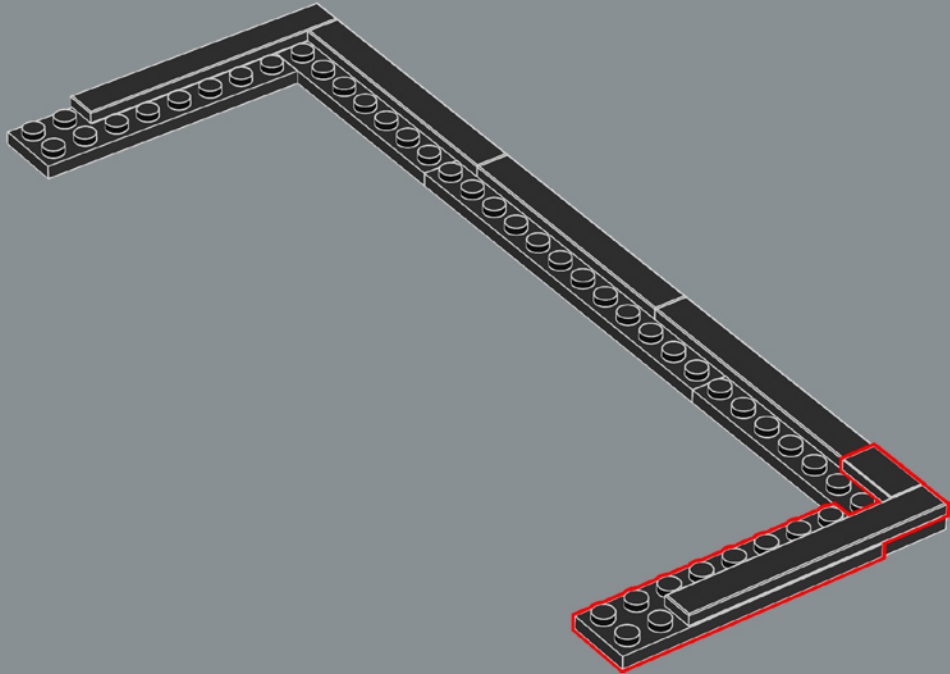

8

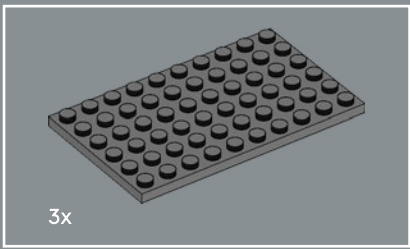

6

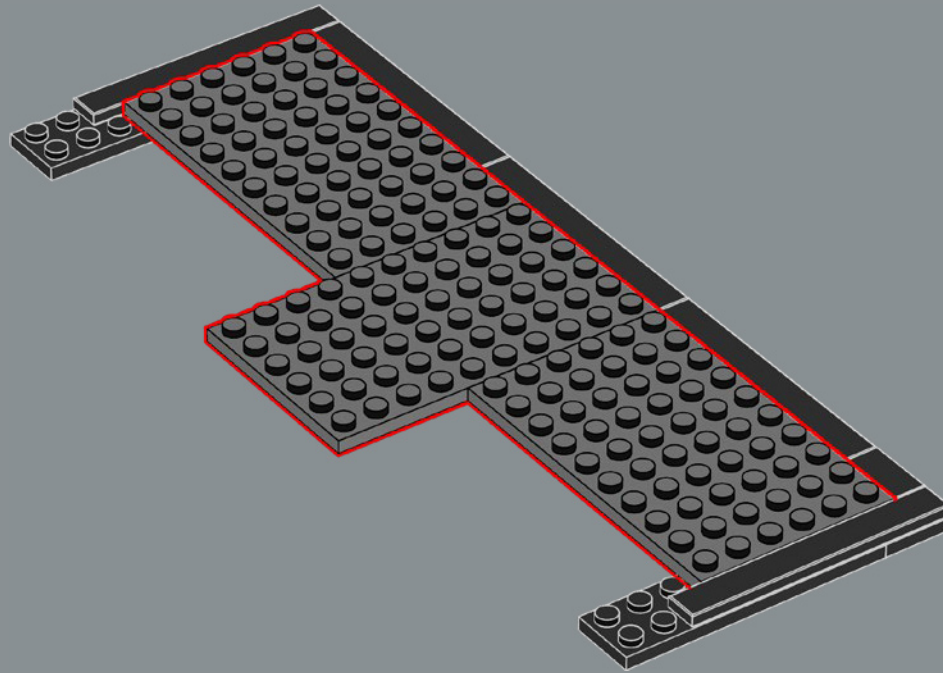

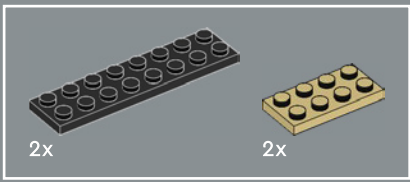

7

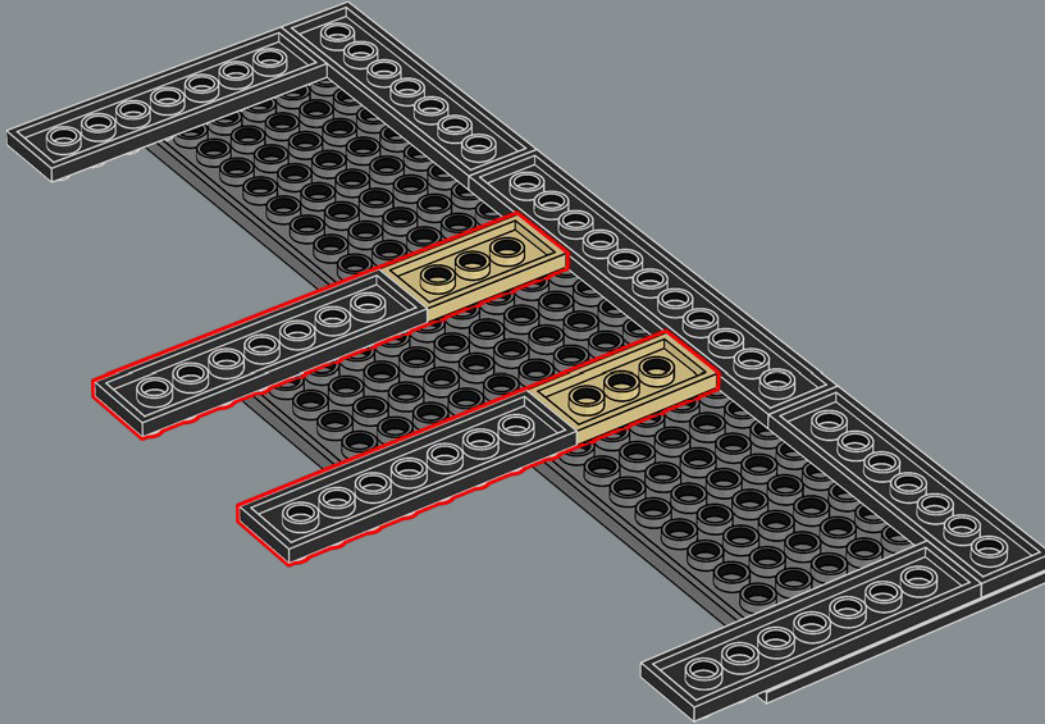

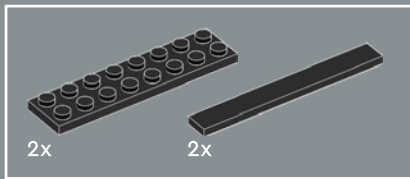

8

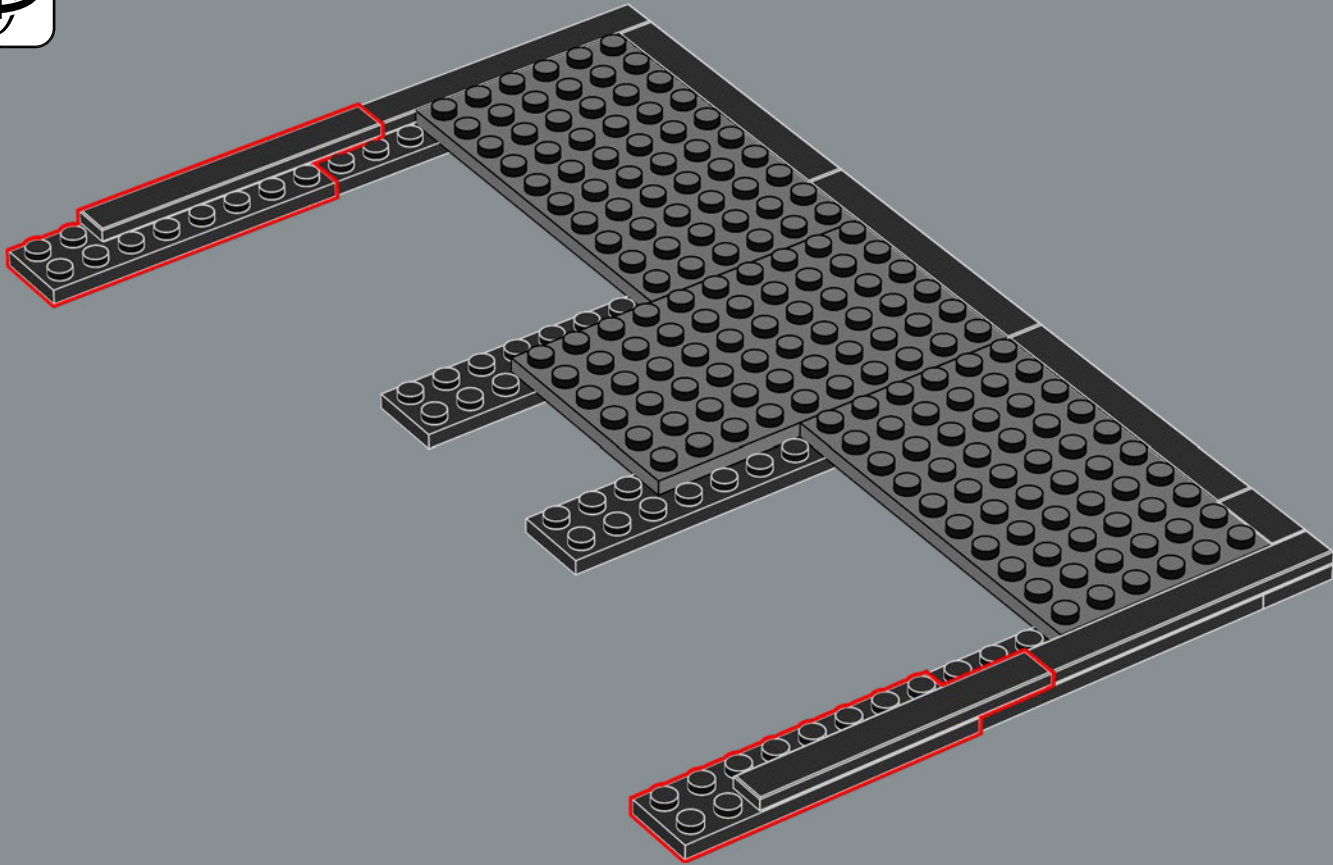

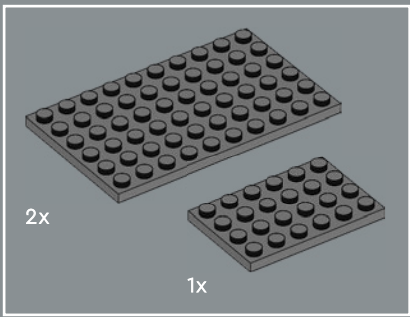

9

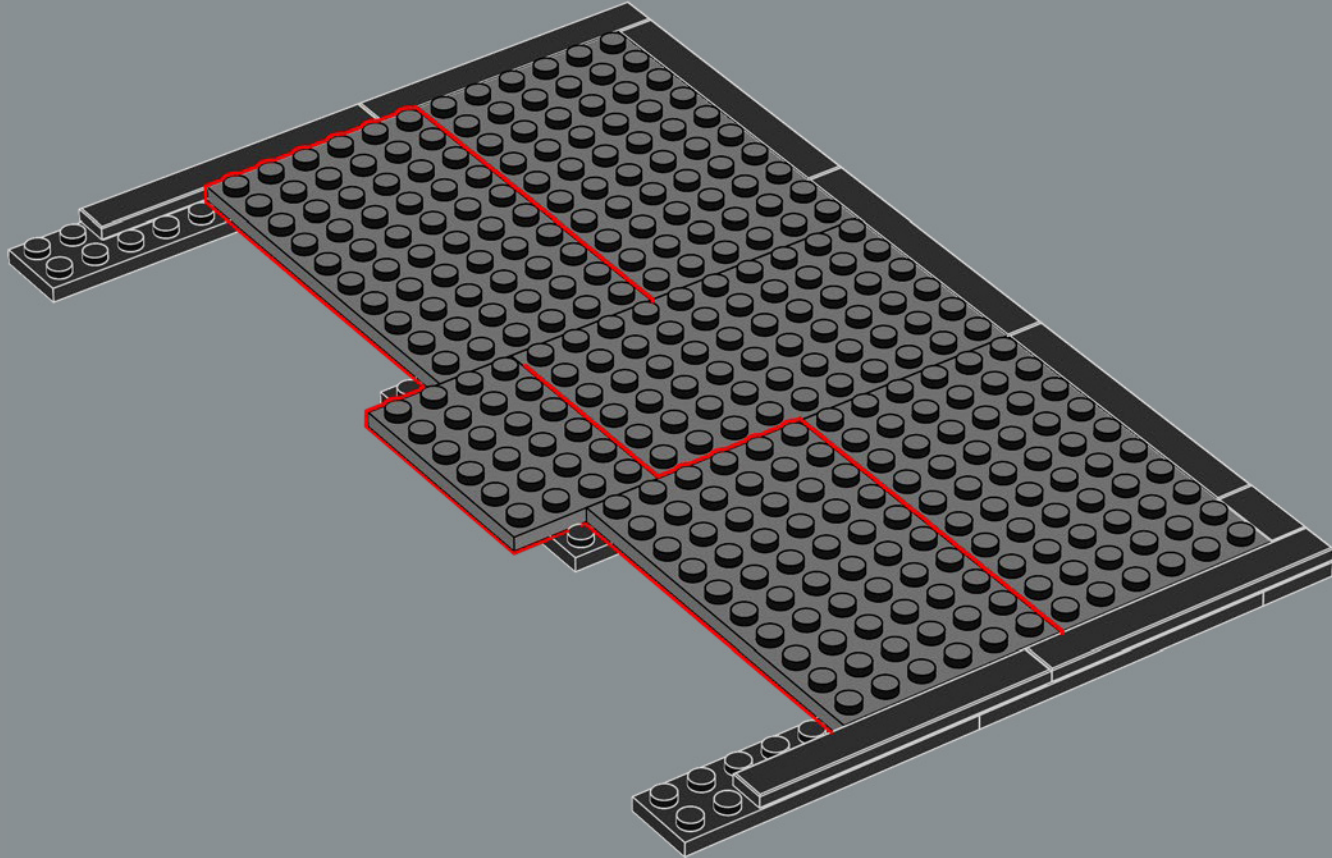

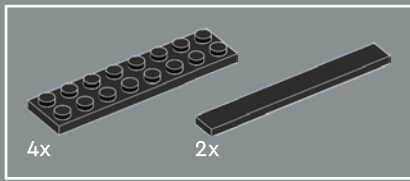

10

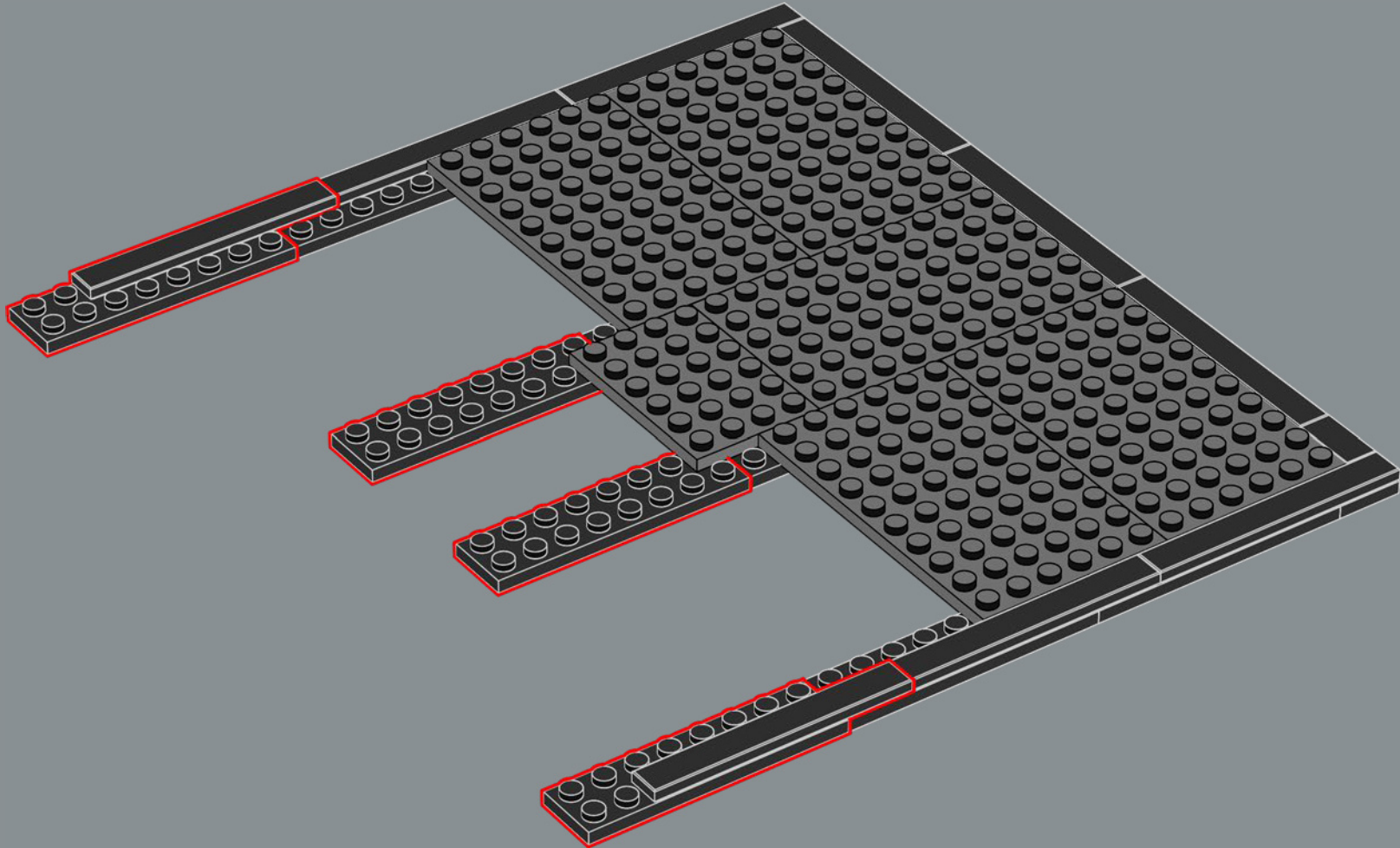

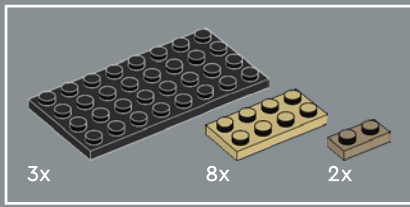

12

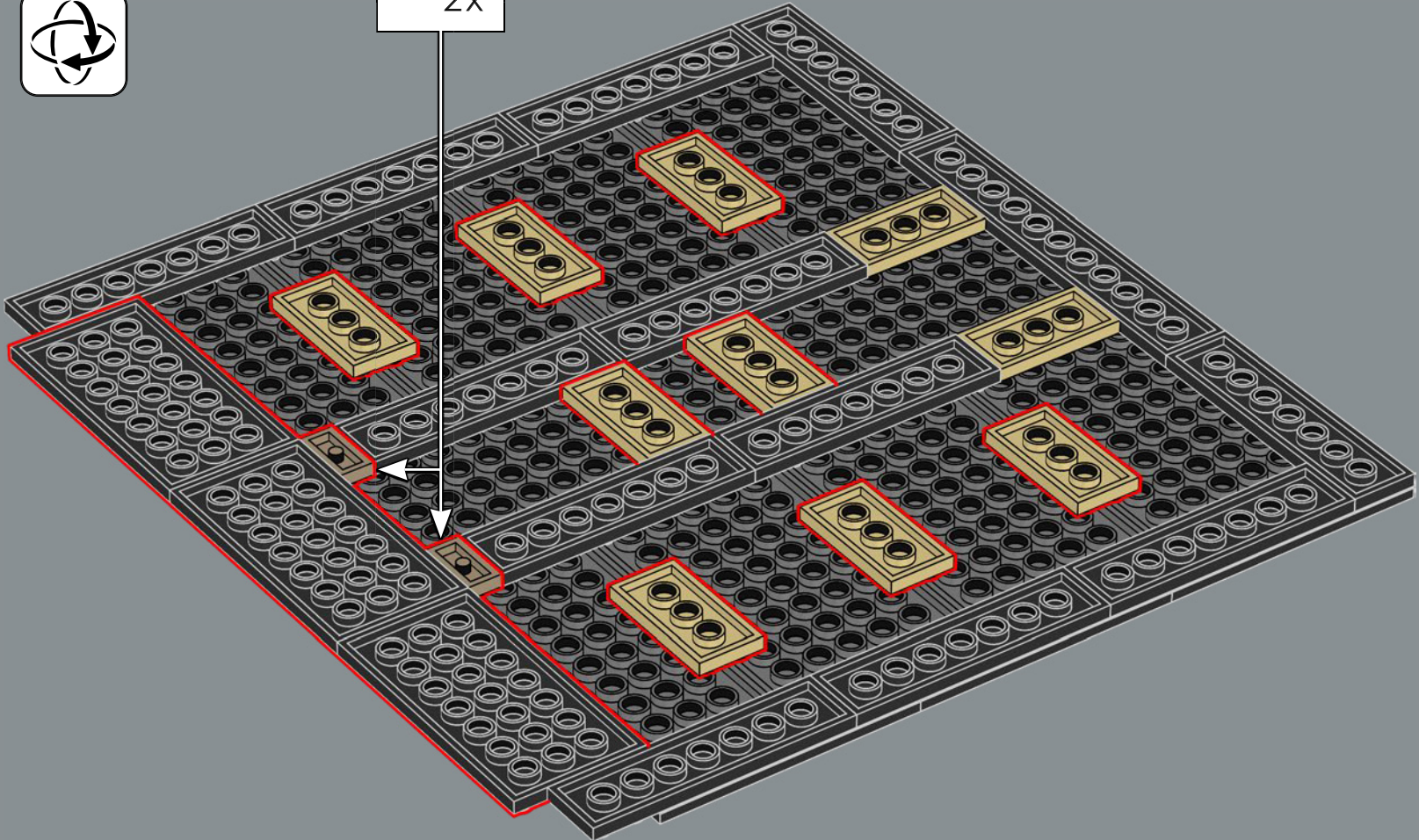
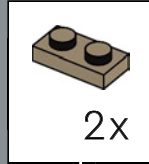

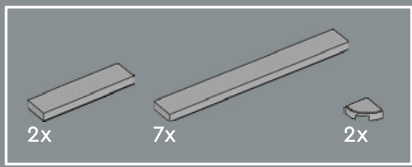

13

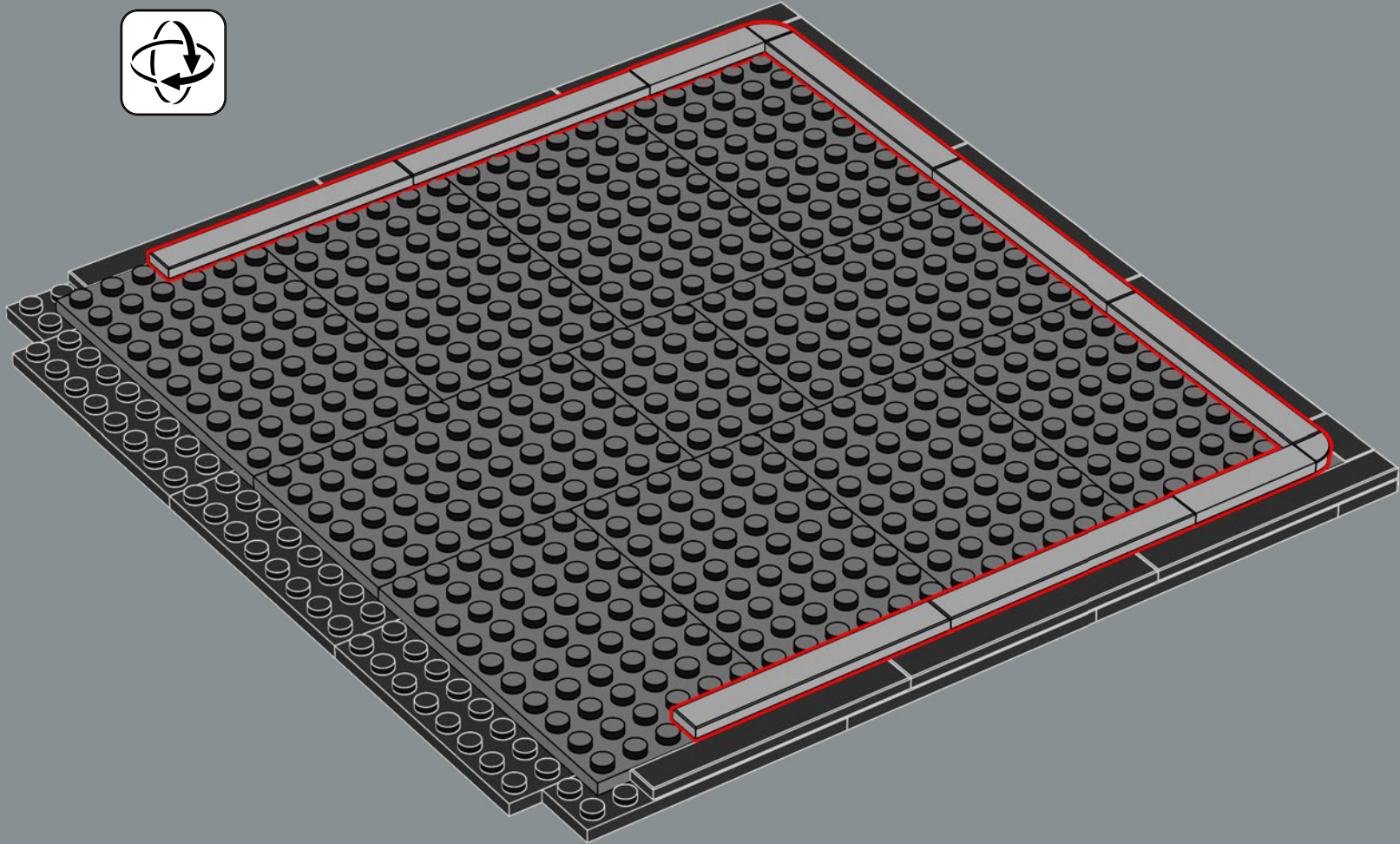

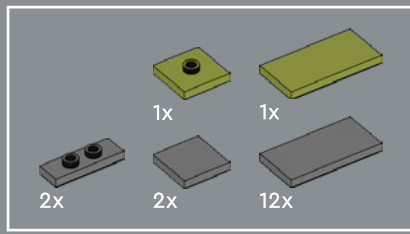

14

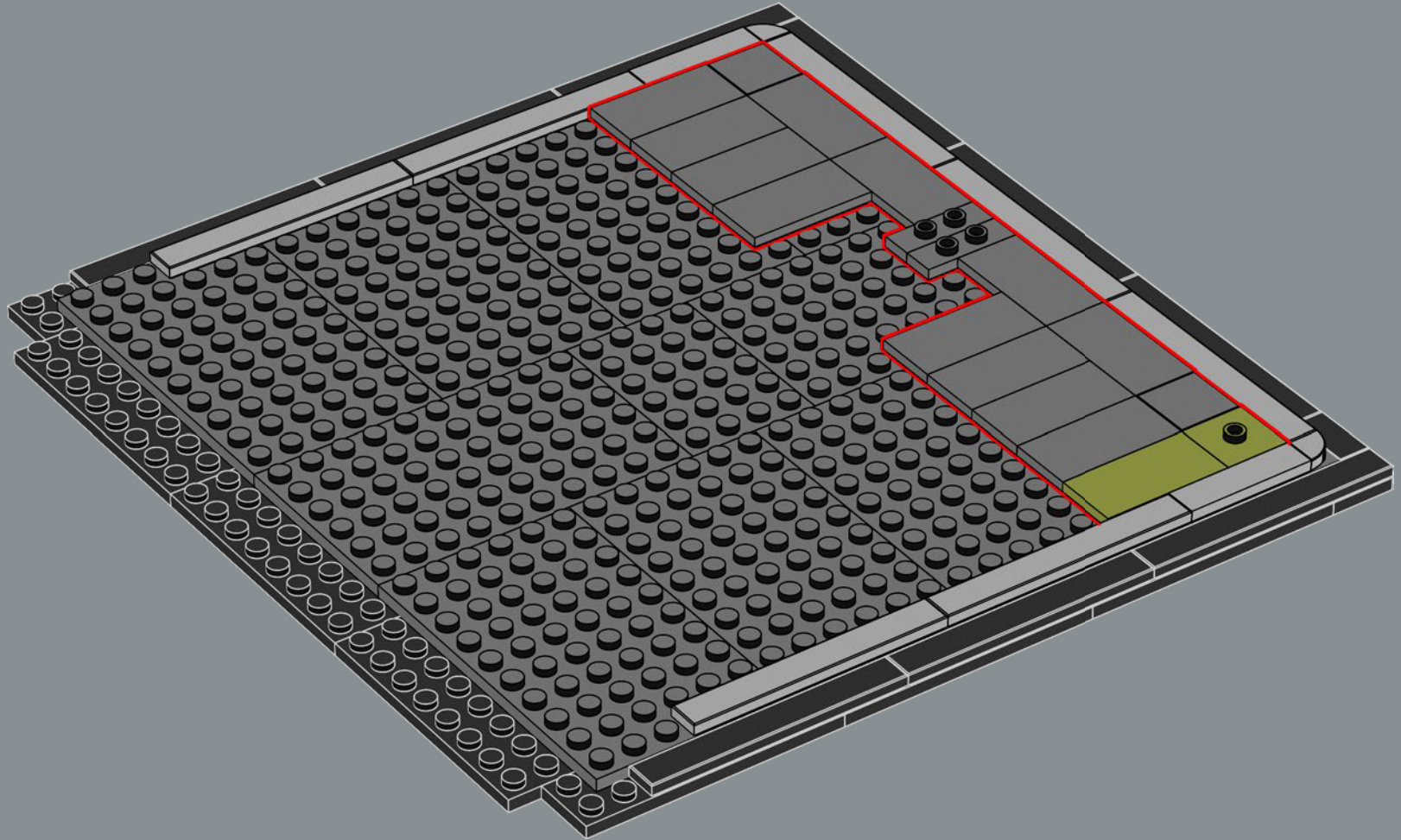

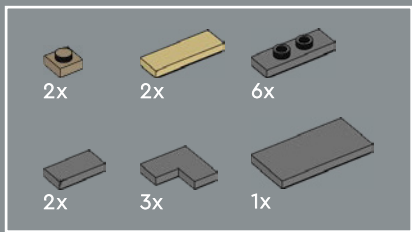

1163 年——完成巴黎圣母院的规划。
亚历山大三世主持巴黎圣母院大教堂正式开工仪式。

15

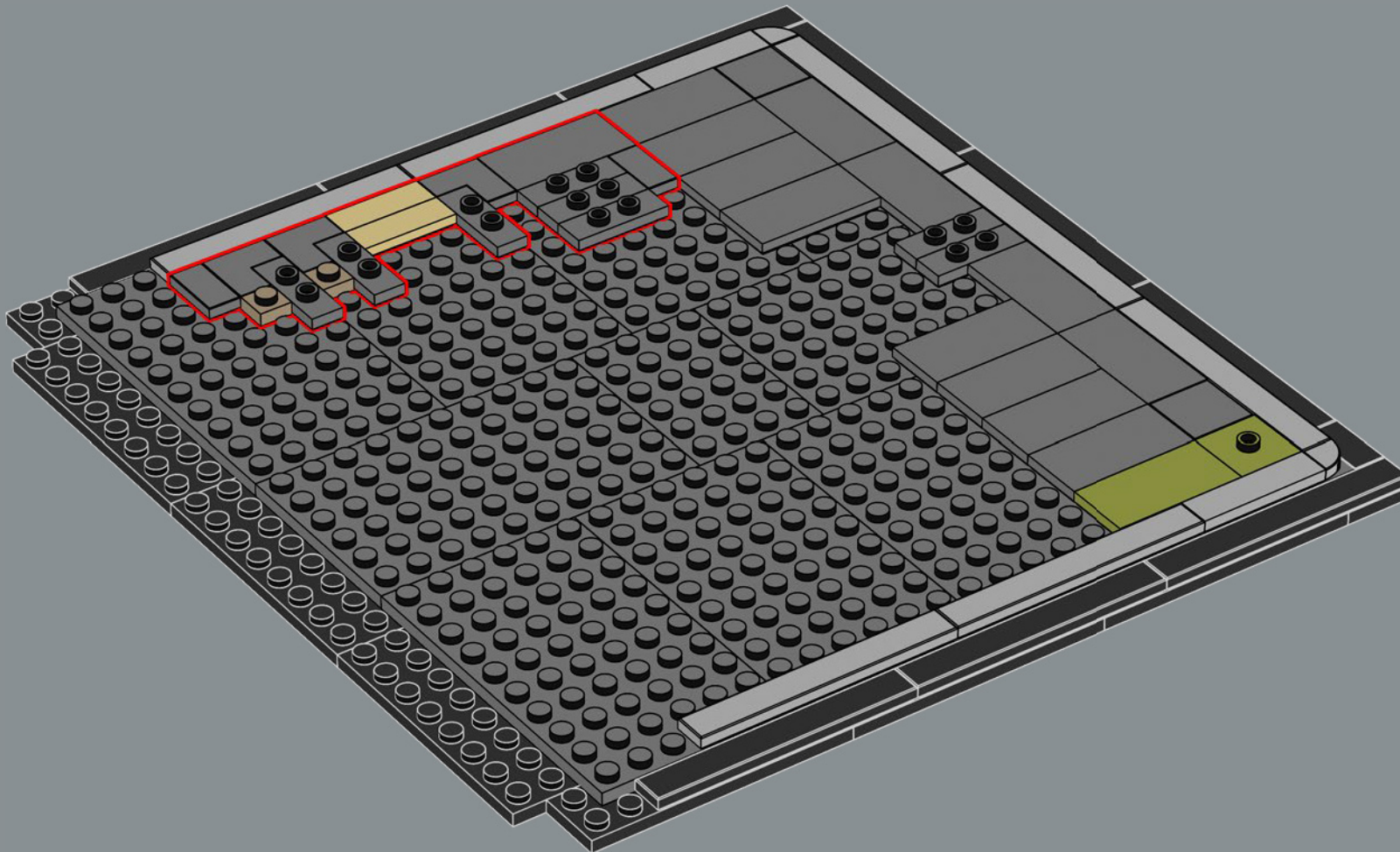

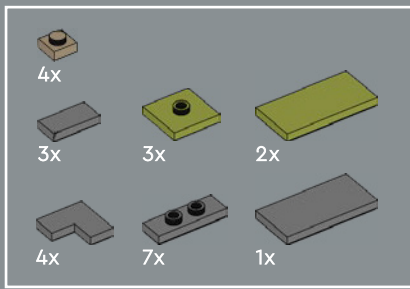

16

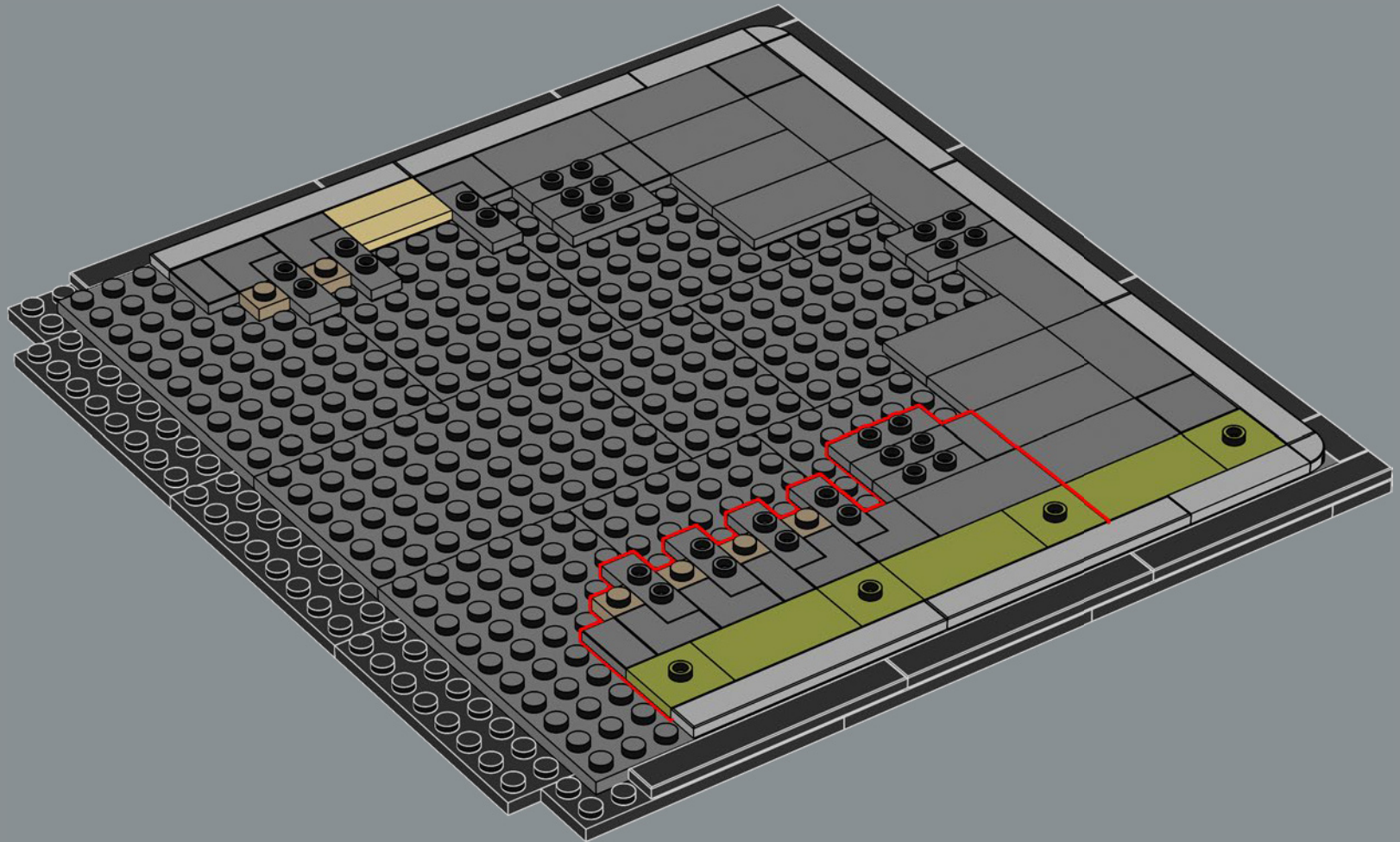



18

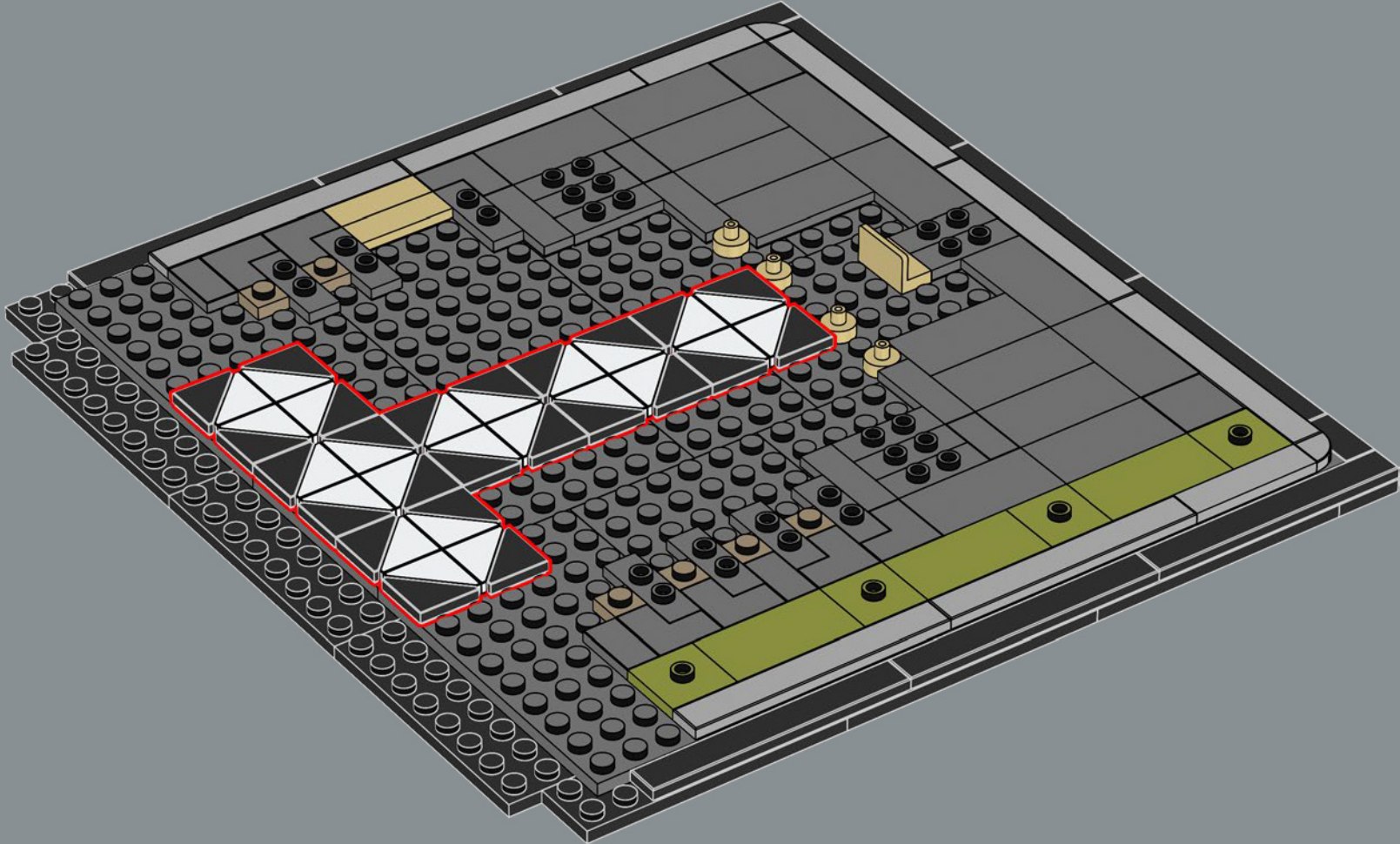



20x

19

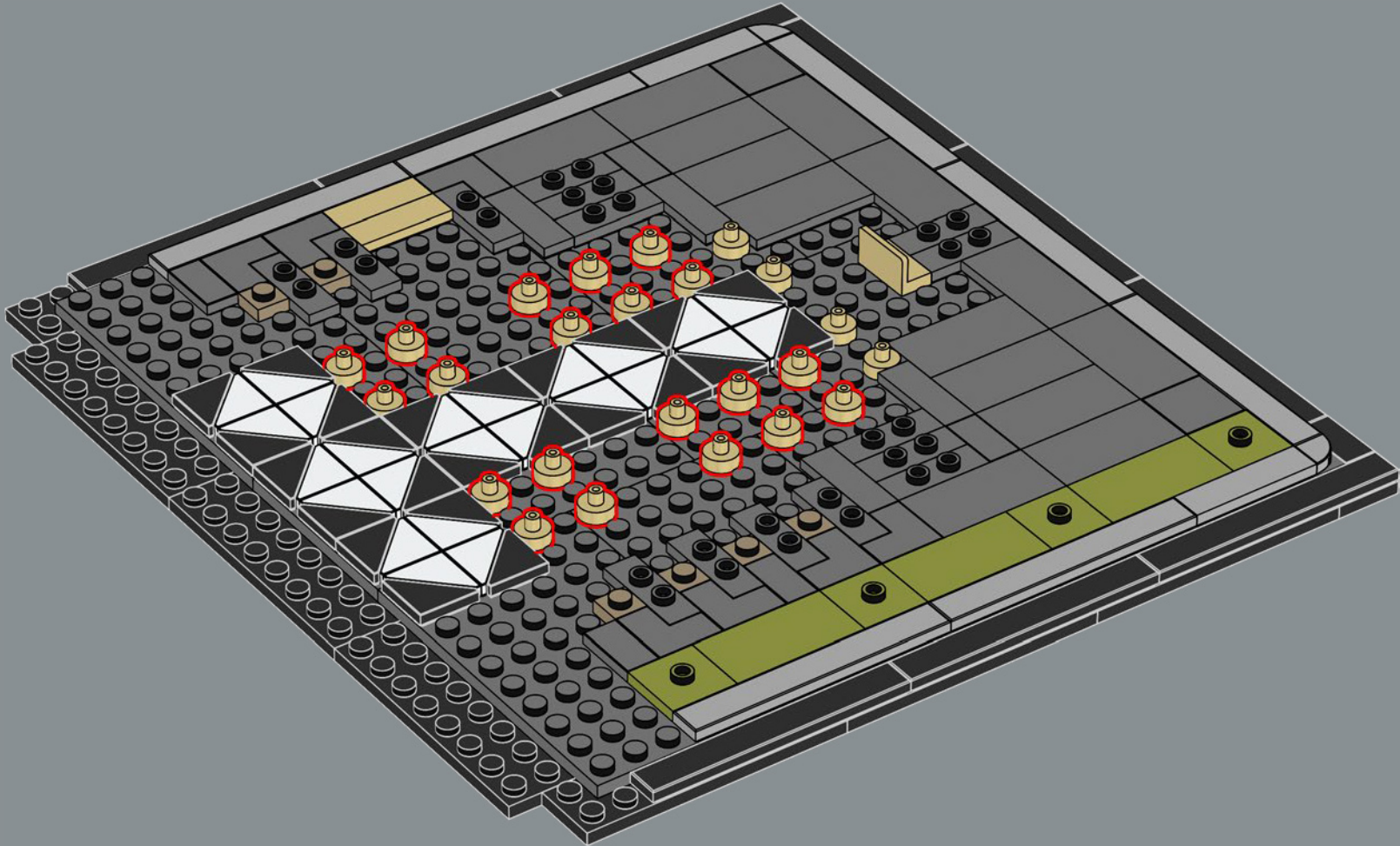

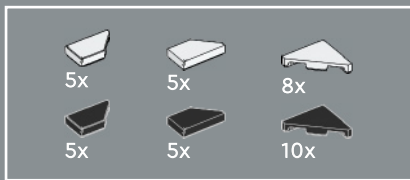

20

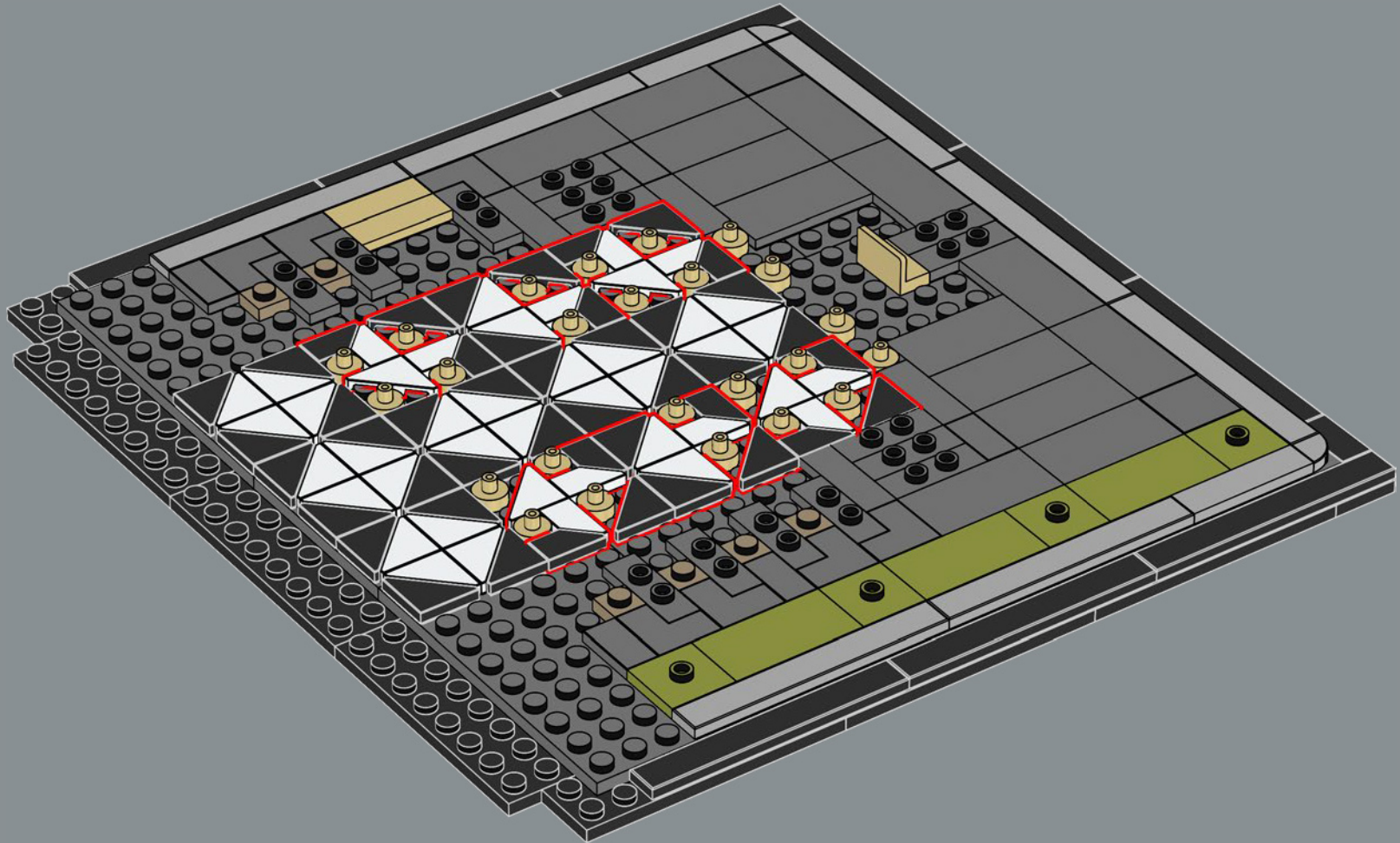

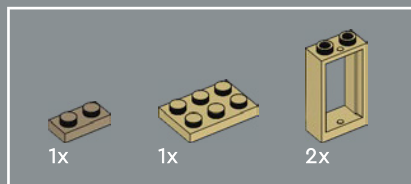

21

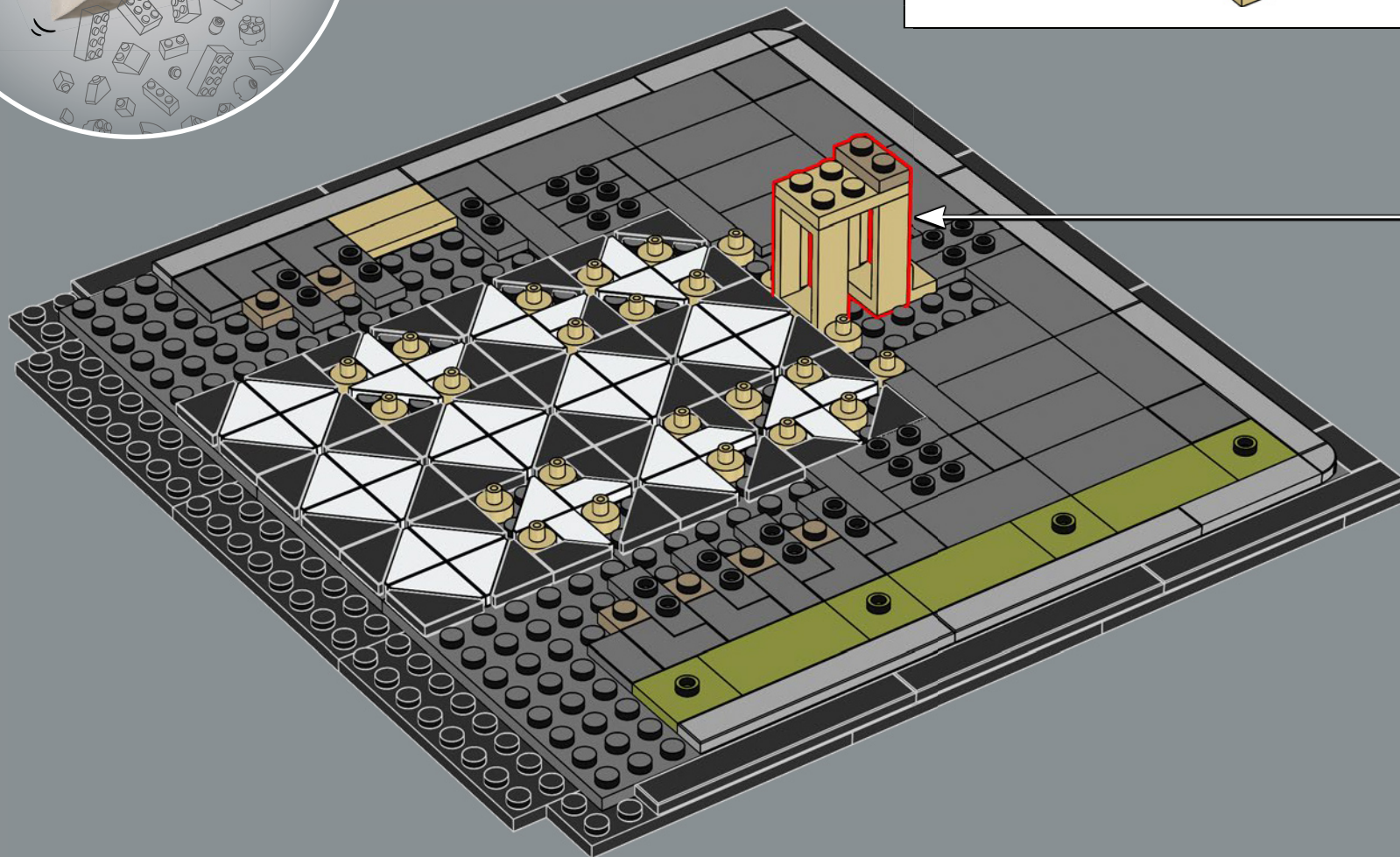
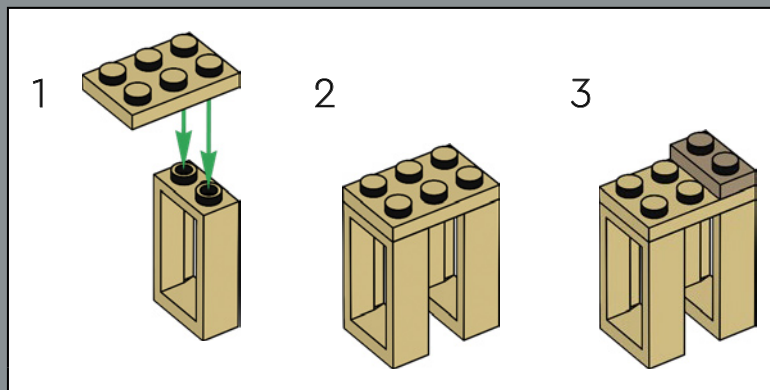

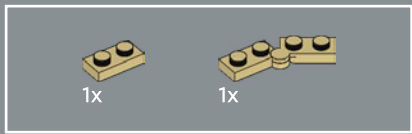

23

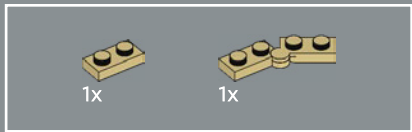
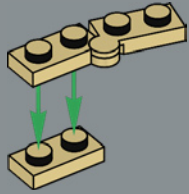

24

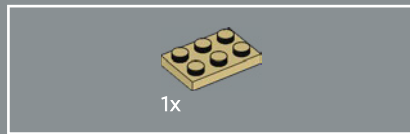
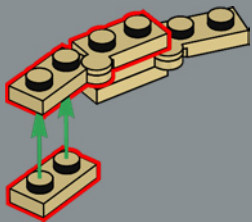

25

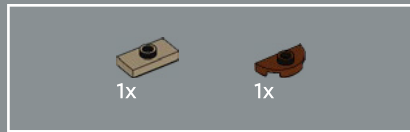
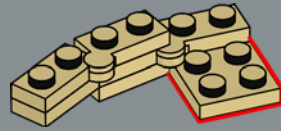

26

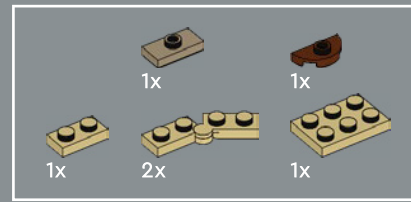
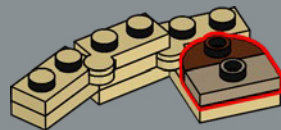

27

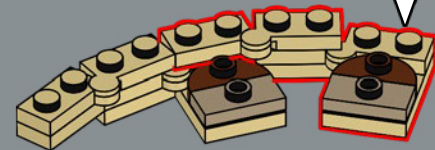
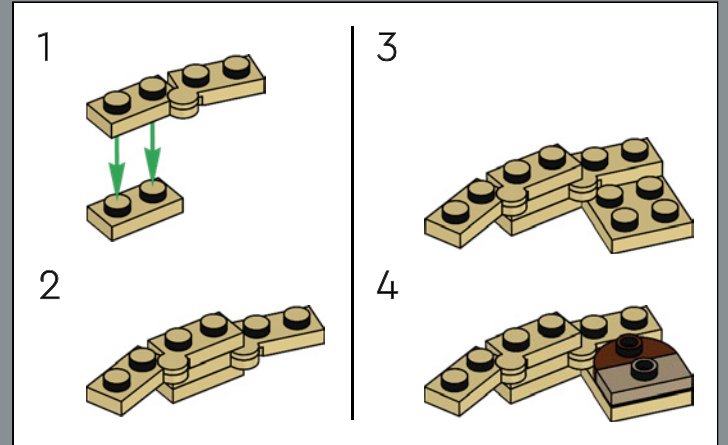

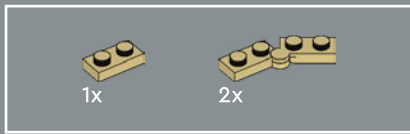

28

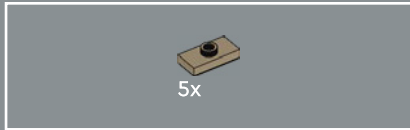
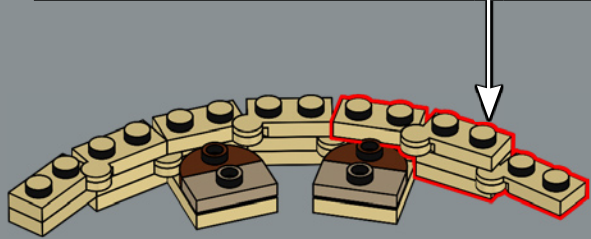
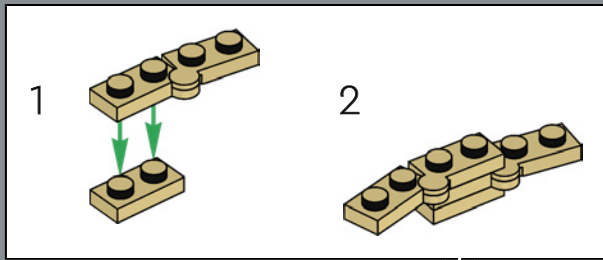

29

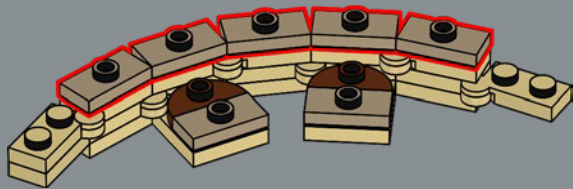

30

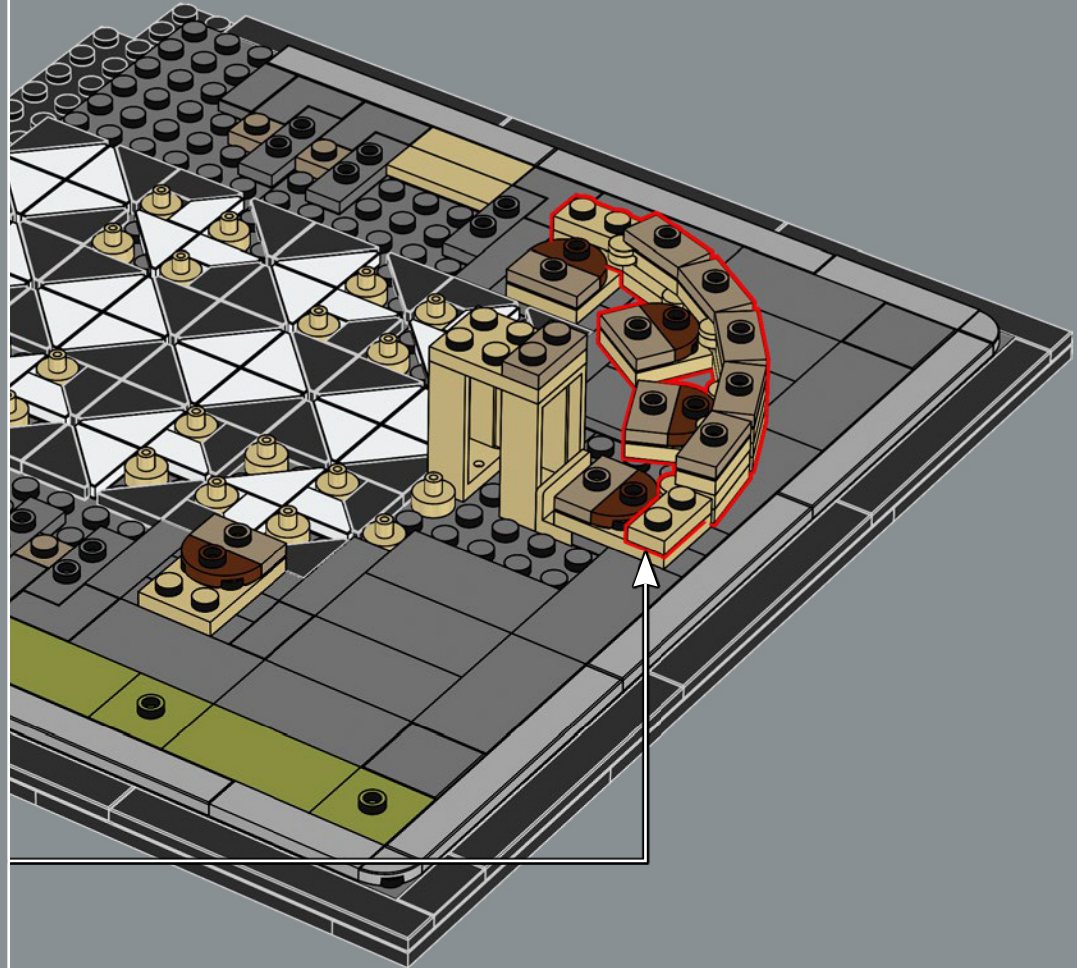

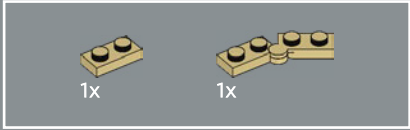
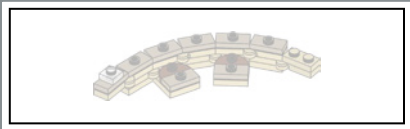

31

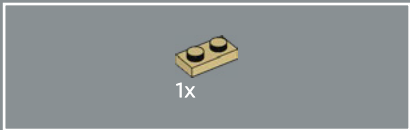
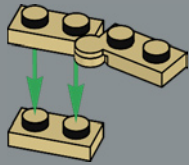

32

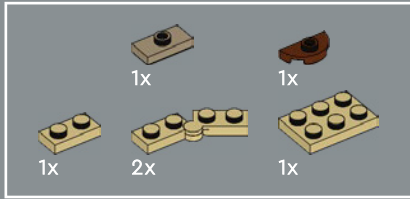

33

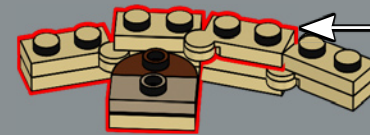
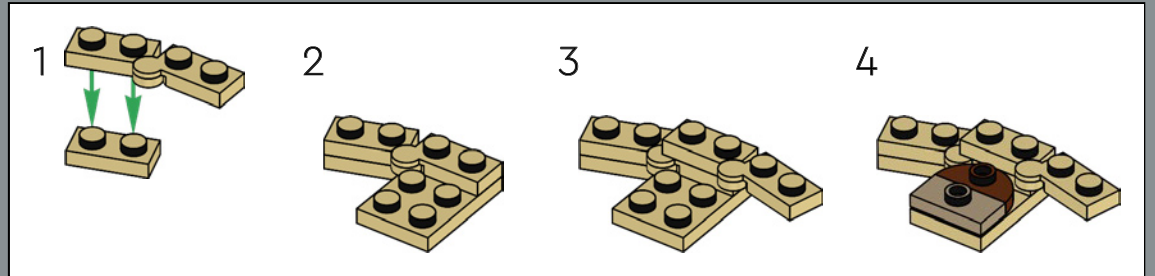

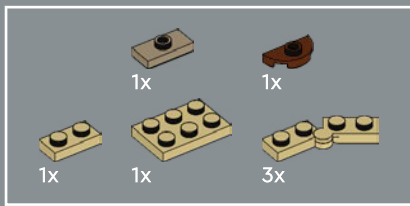

34

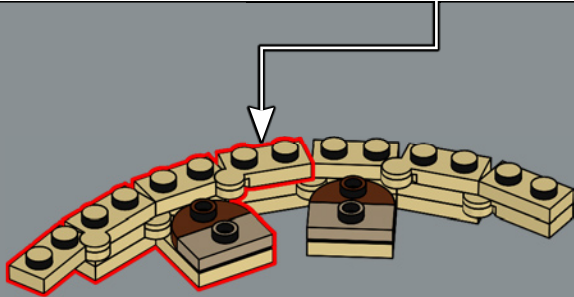
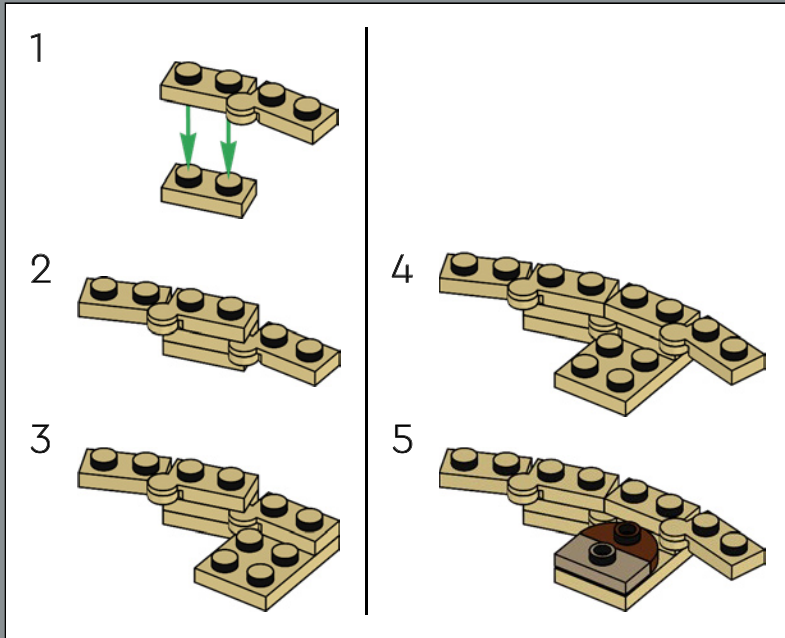

35

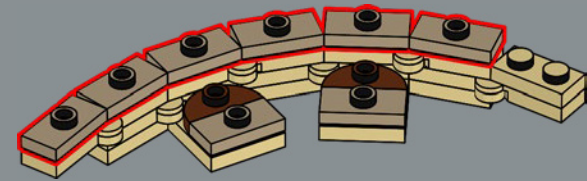

36

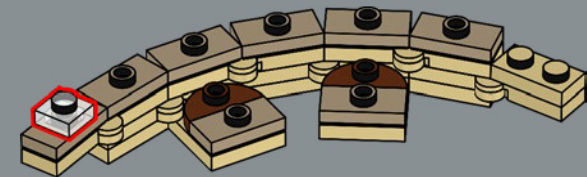

1163 年——平面图的不同部分是由一系列圆圈确定的，
而这些圆圈是由连接到大教堂中心桩子上的不同长度的
绳索构成的。

37

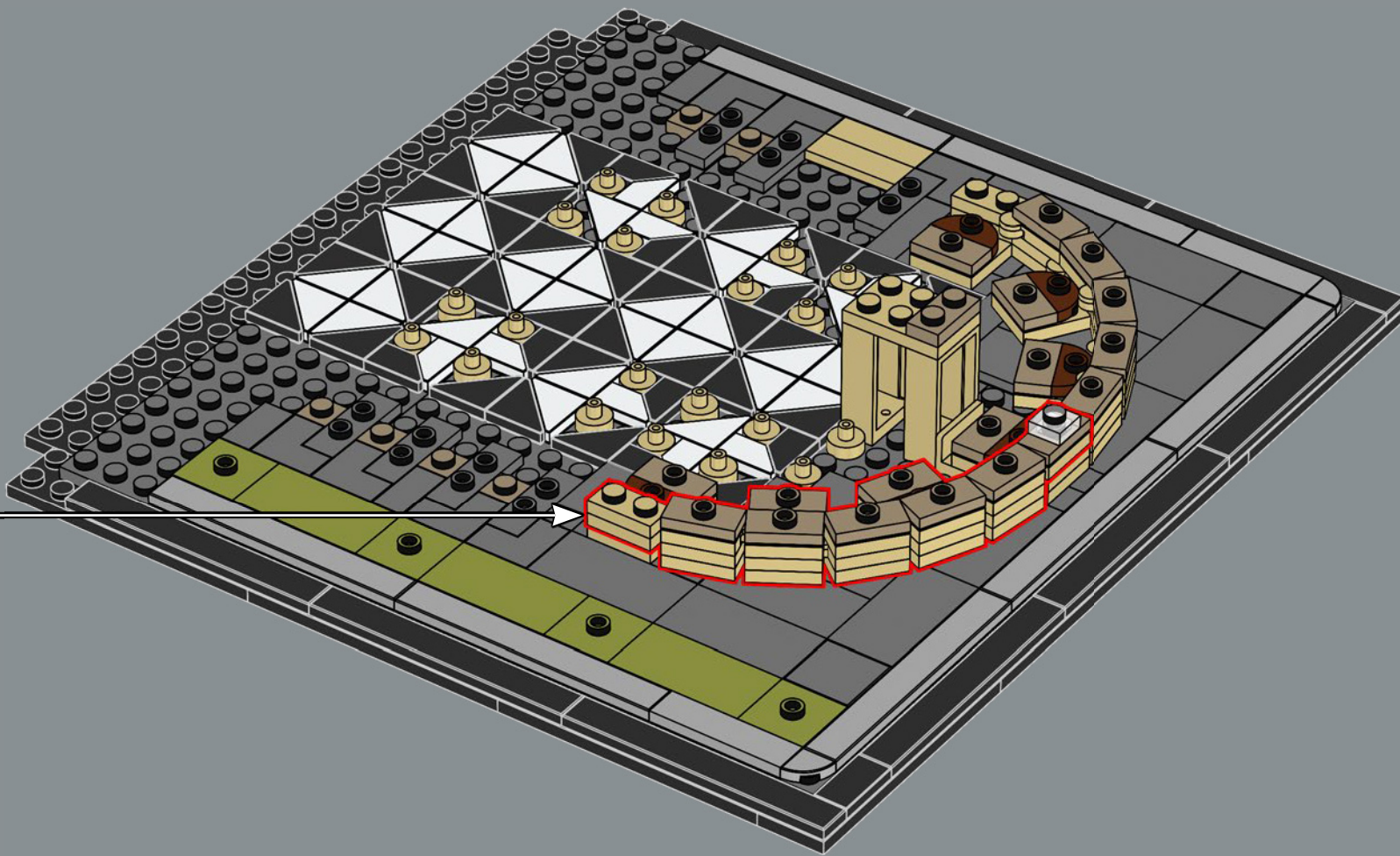

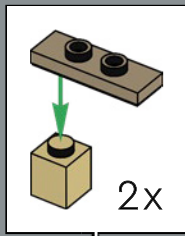
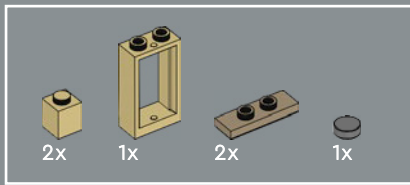

38

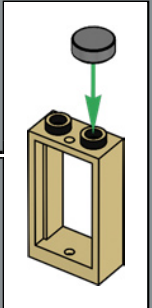
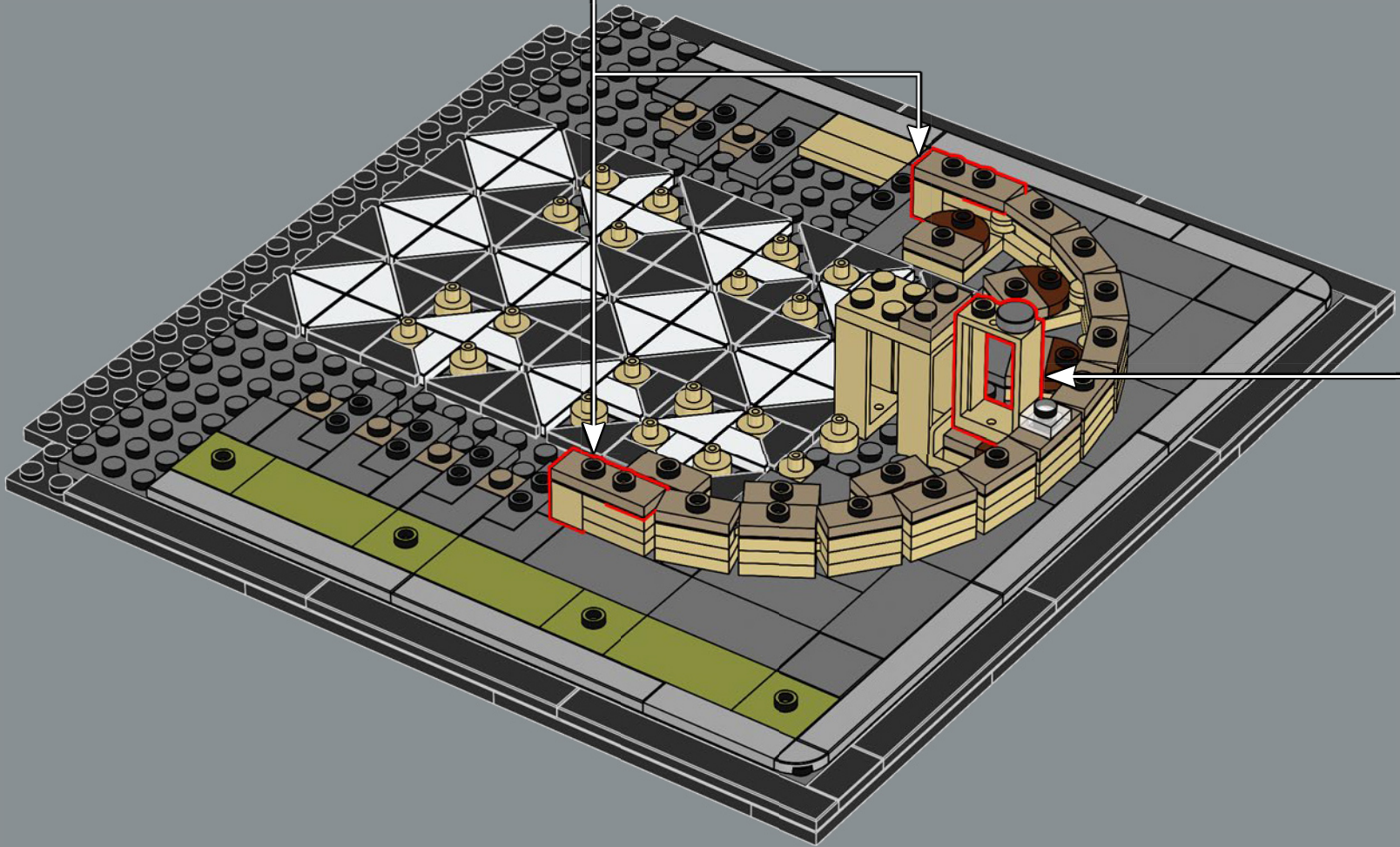

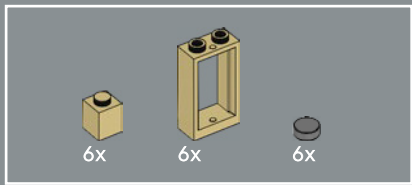

39

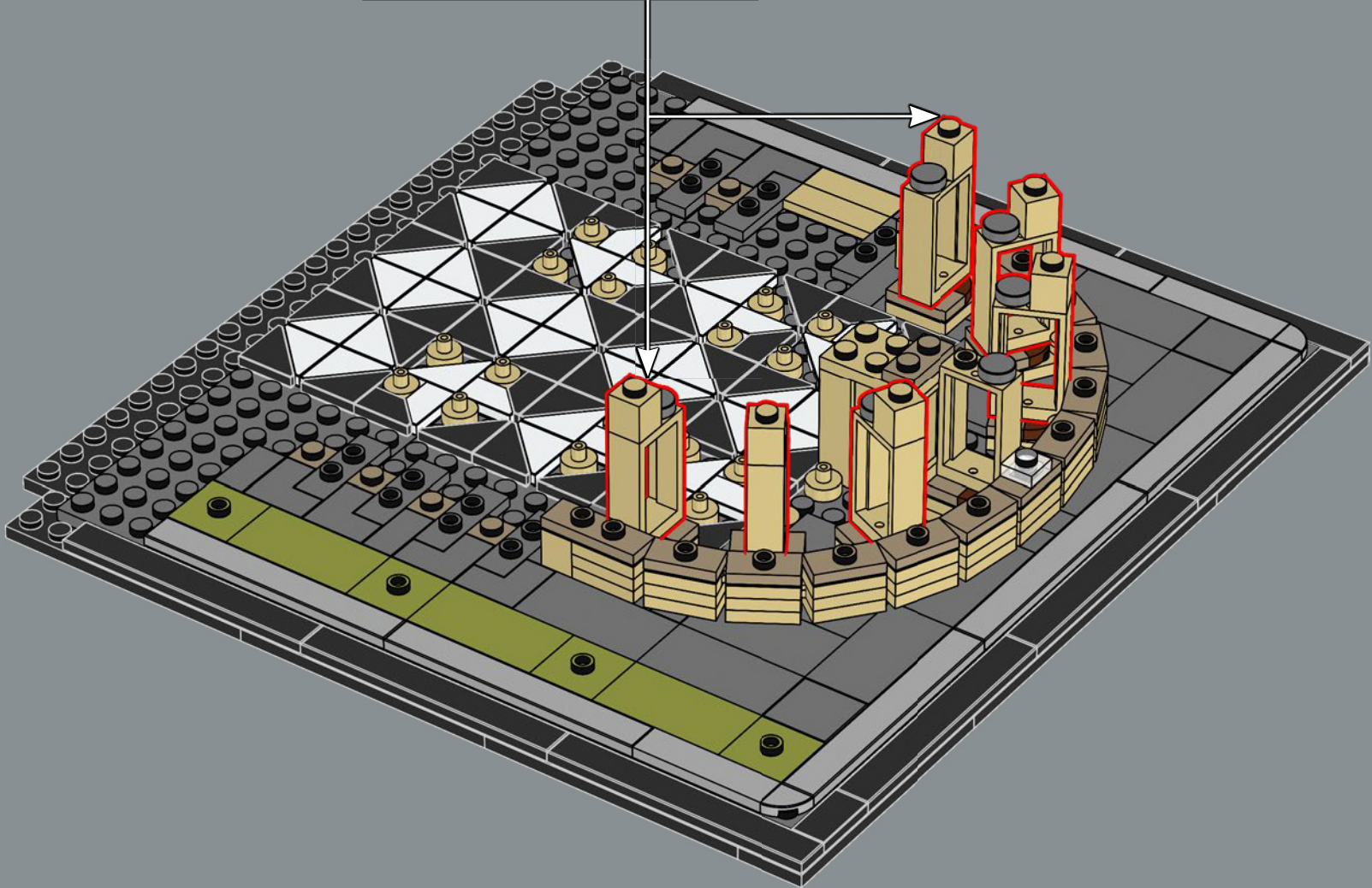
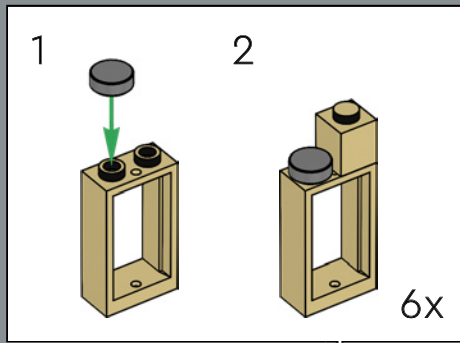



40

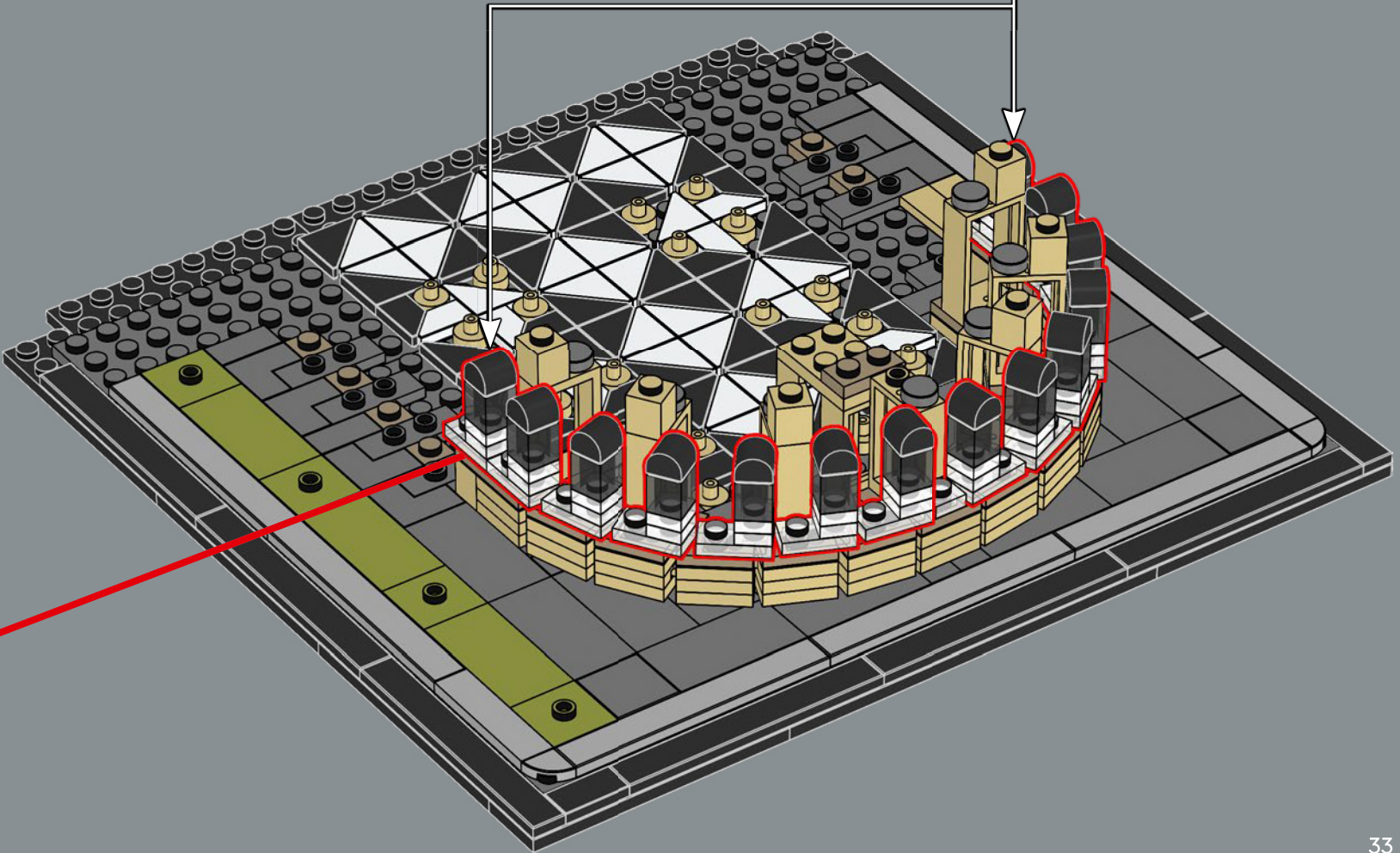
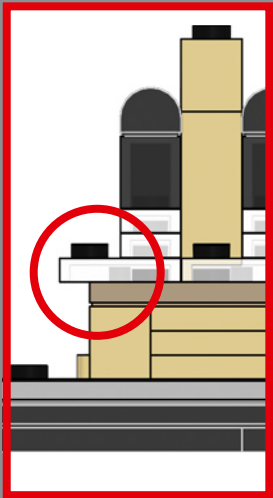
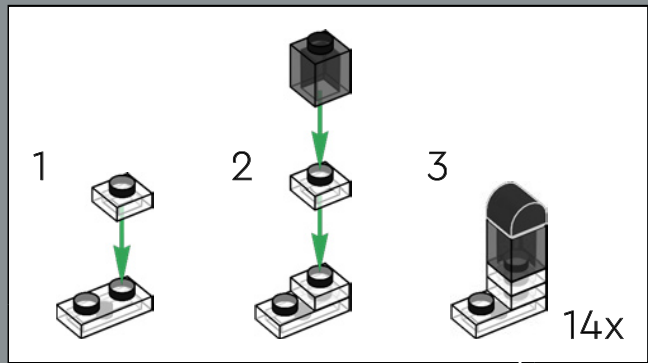

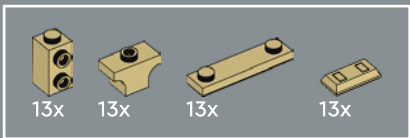

41

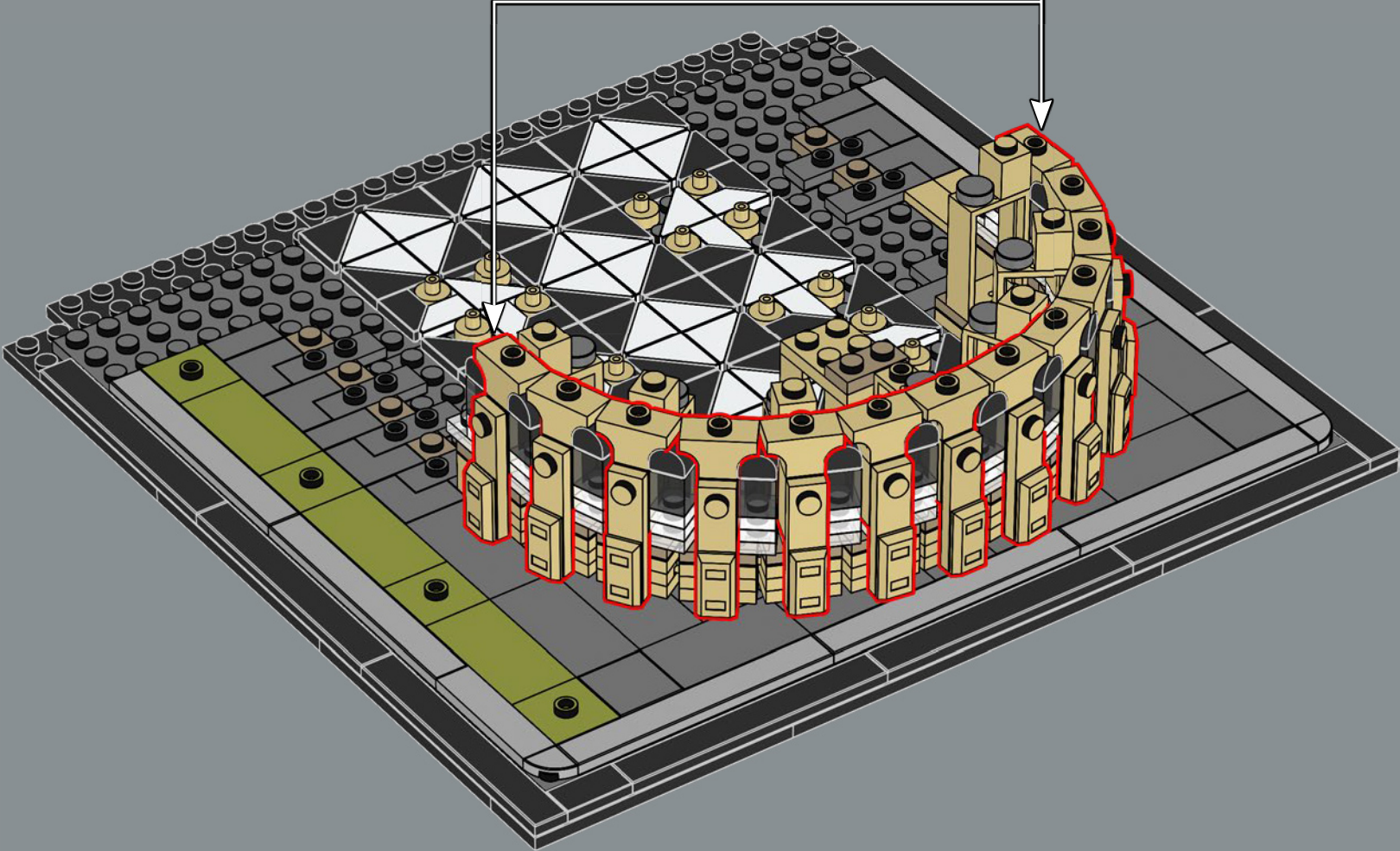
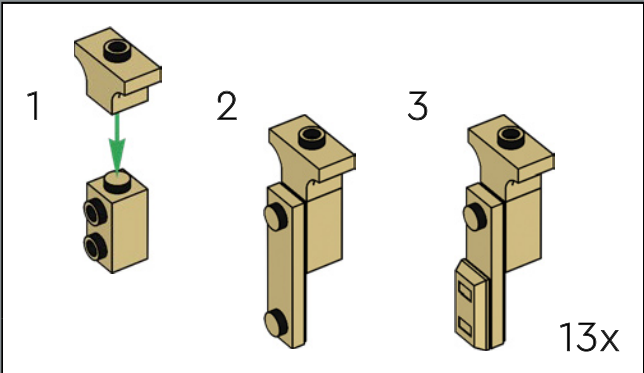

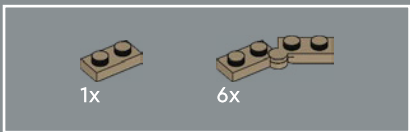

42

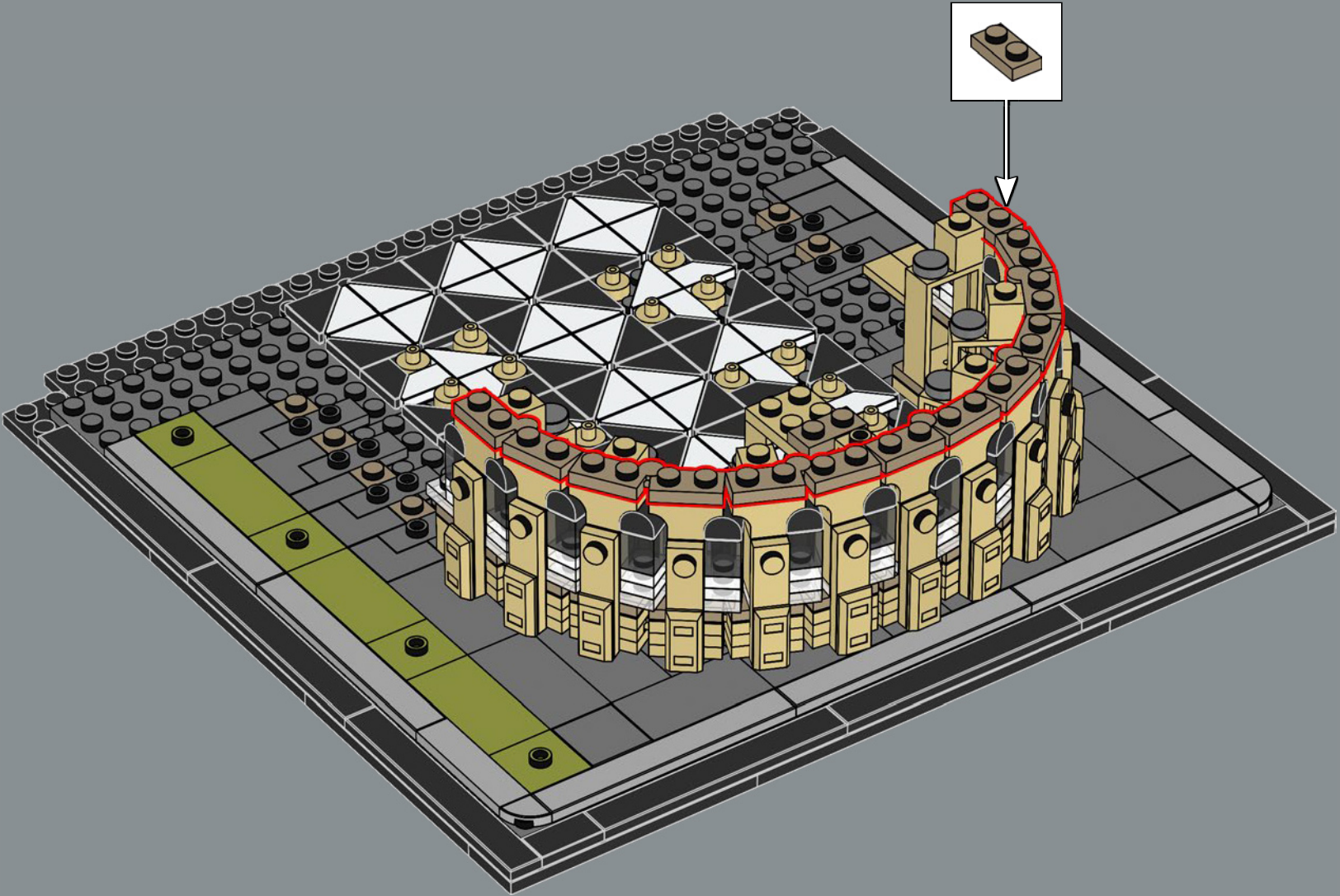

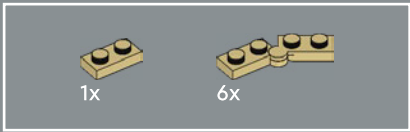

43

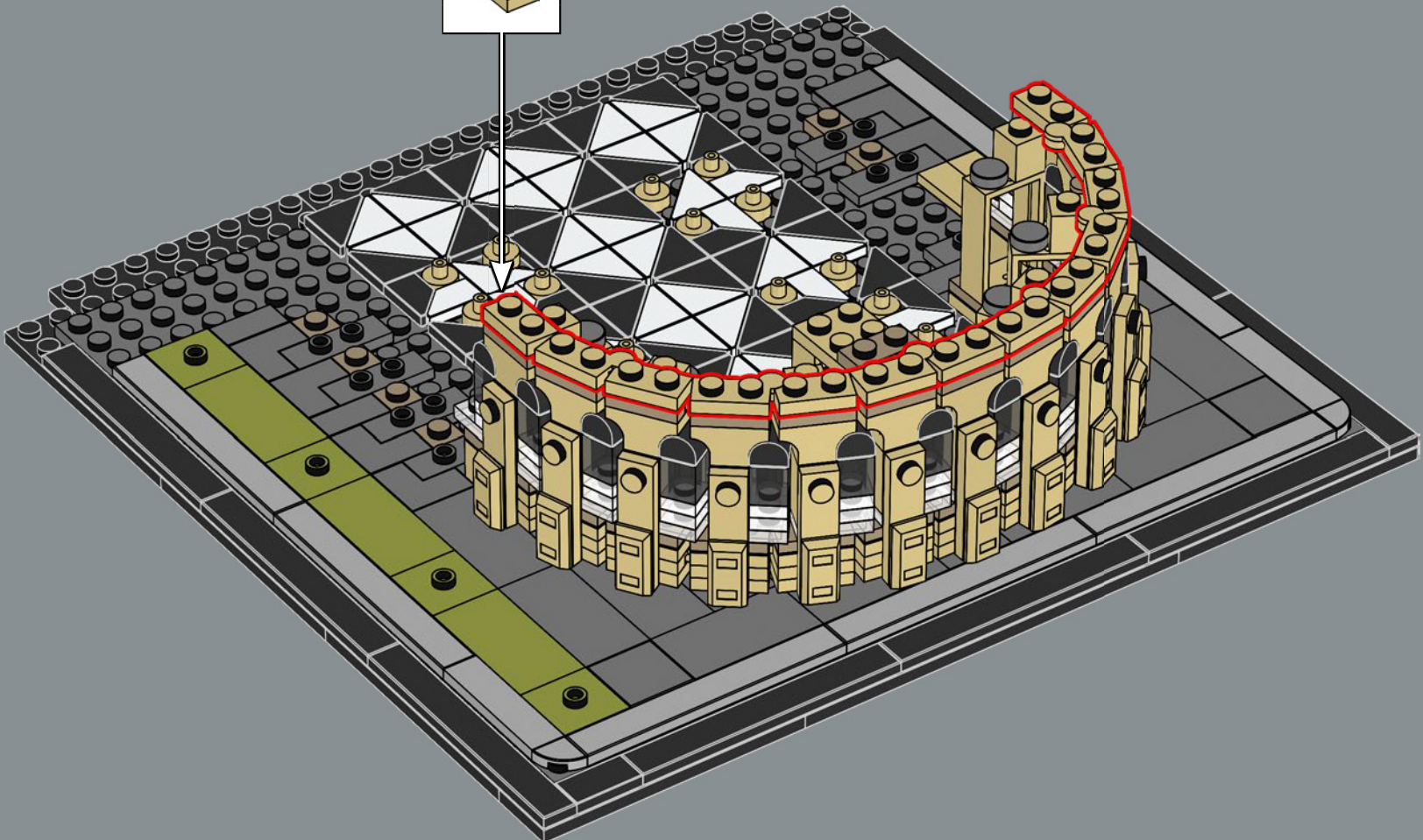
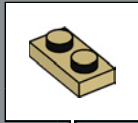

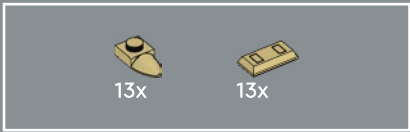

44

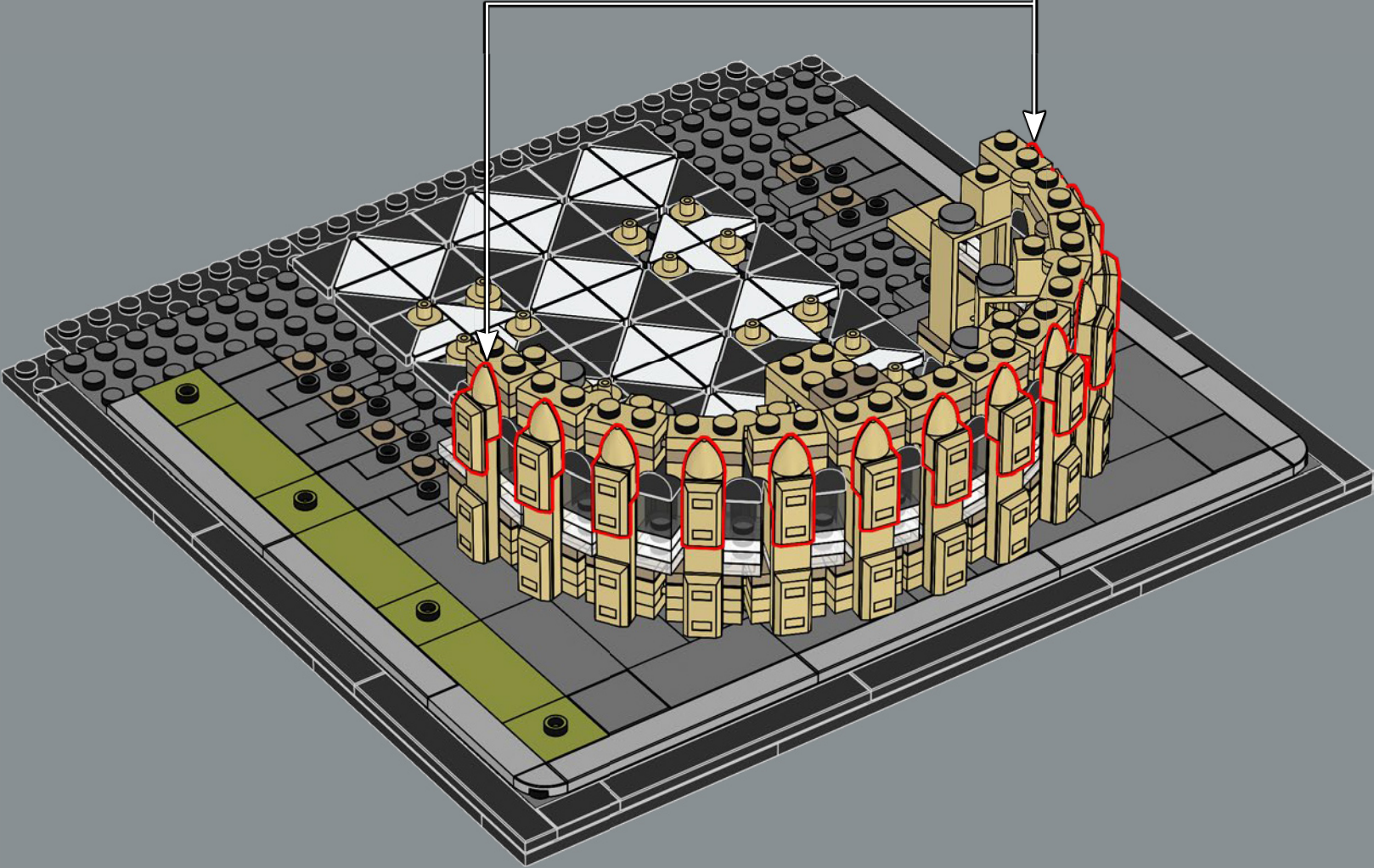
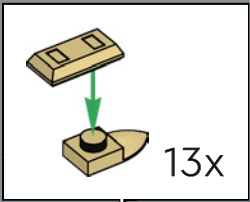

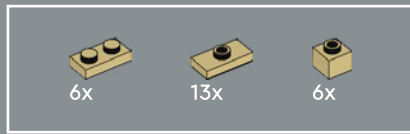

45

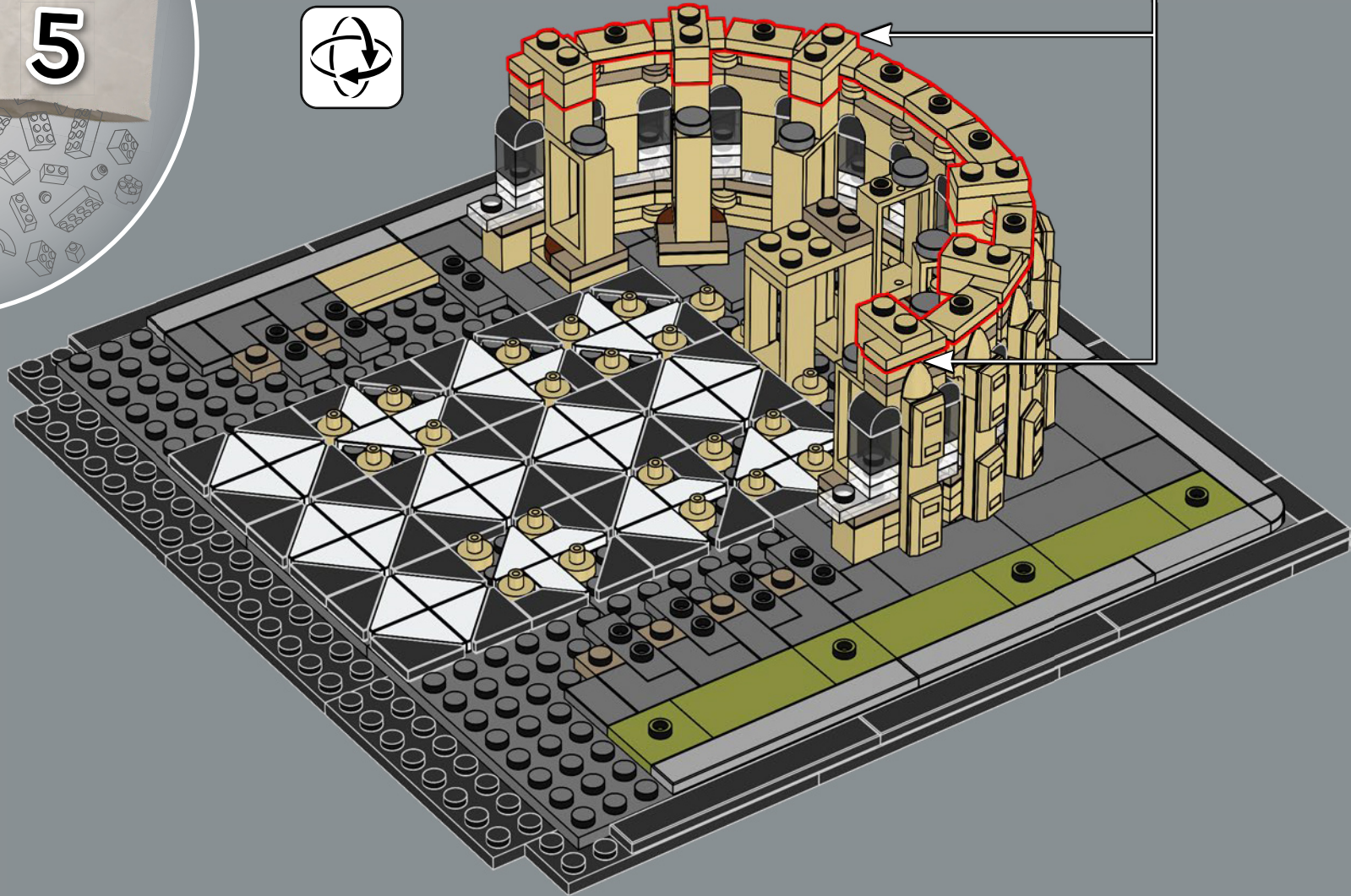
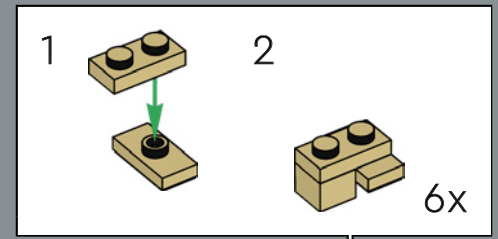



46

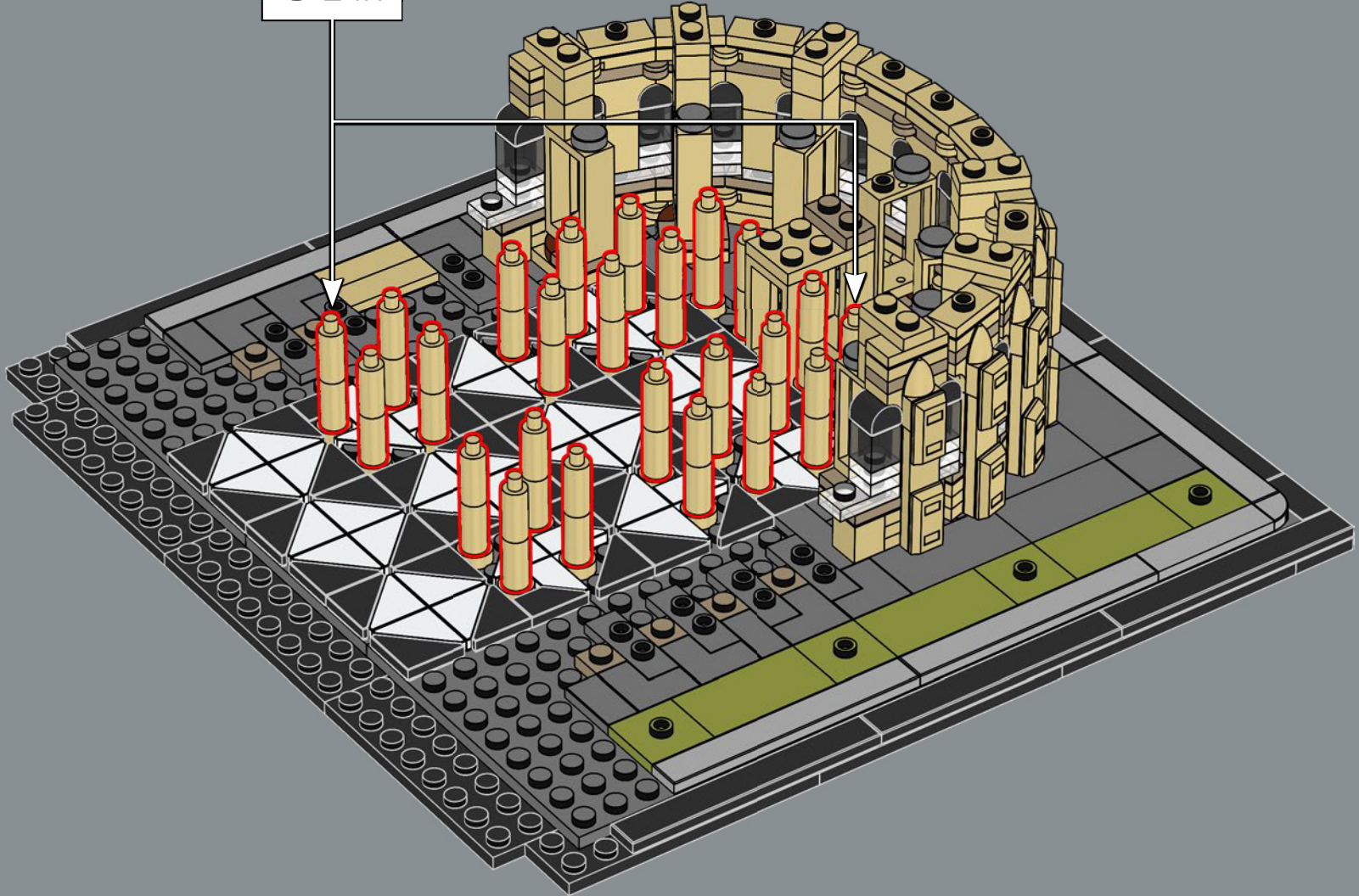
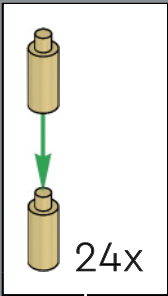

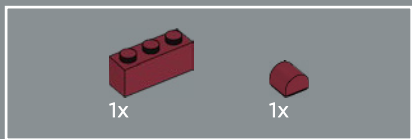

47

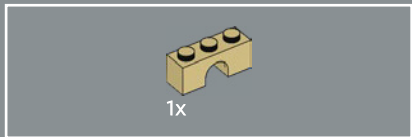
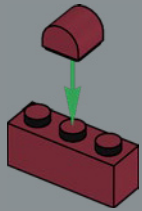

48

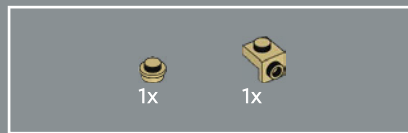
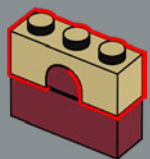

49

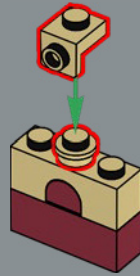

50

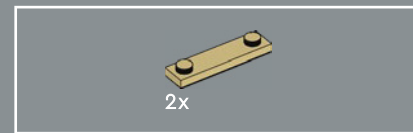
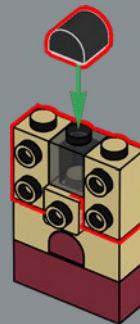

51

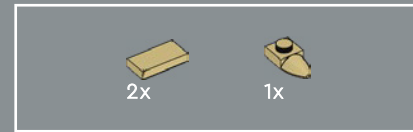
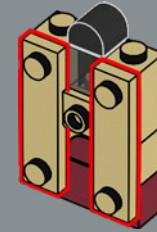

52

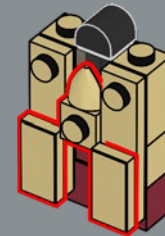

通过一道优雅的门可直接进入唱诗堂，该门户的名字
(红门 The Porte Rouge) 源于其窗格的颜色。
它在 1270 年左右进行了翻新。

53

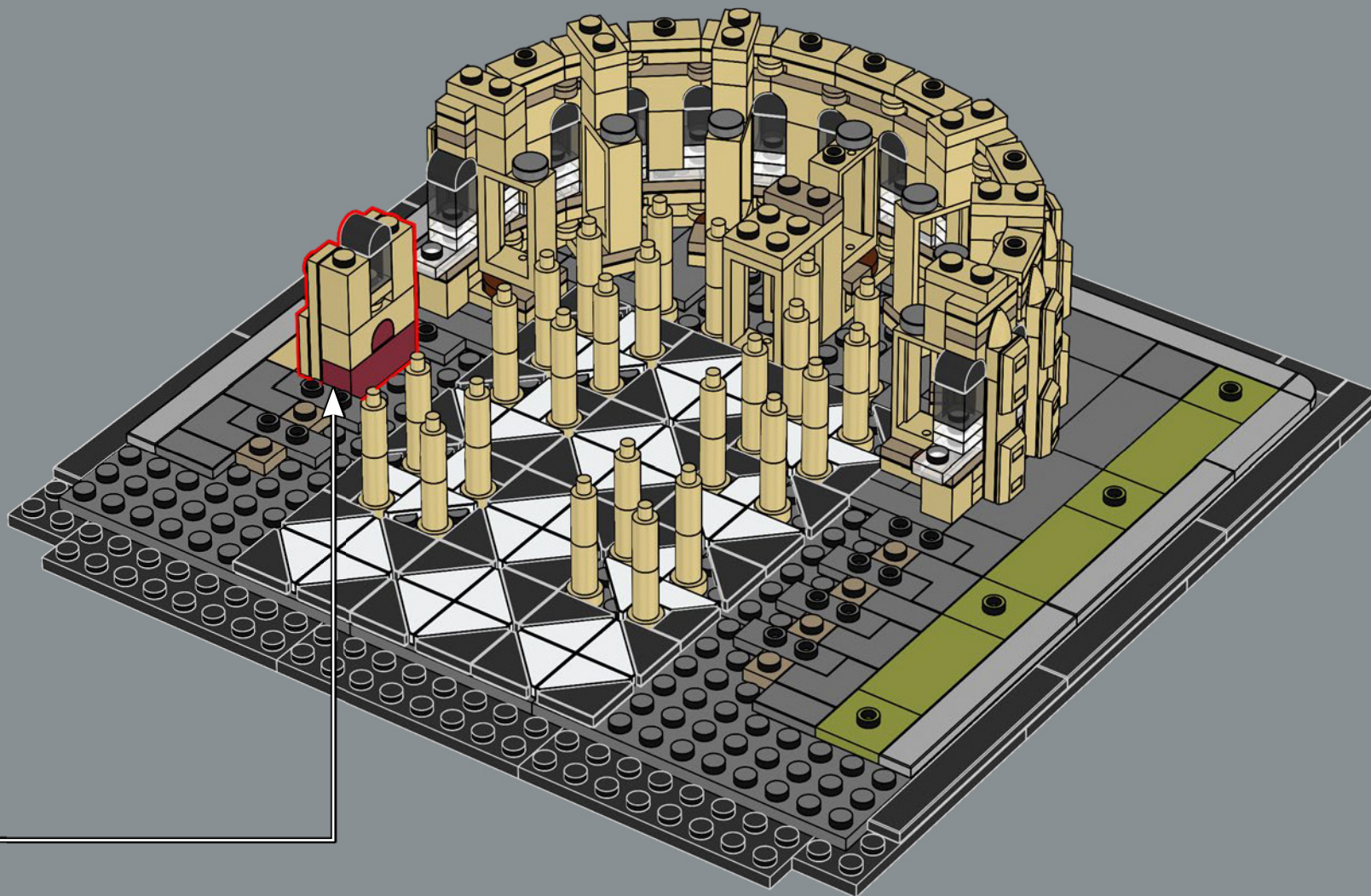

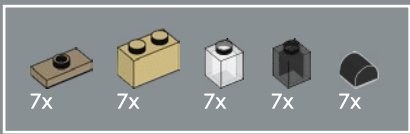

54

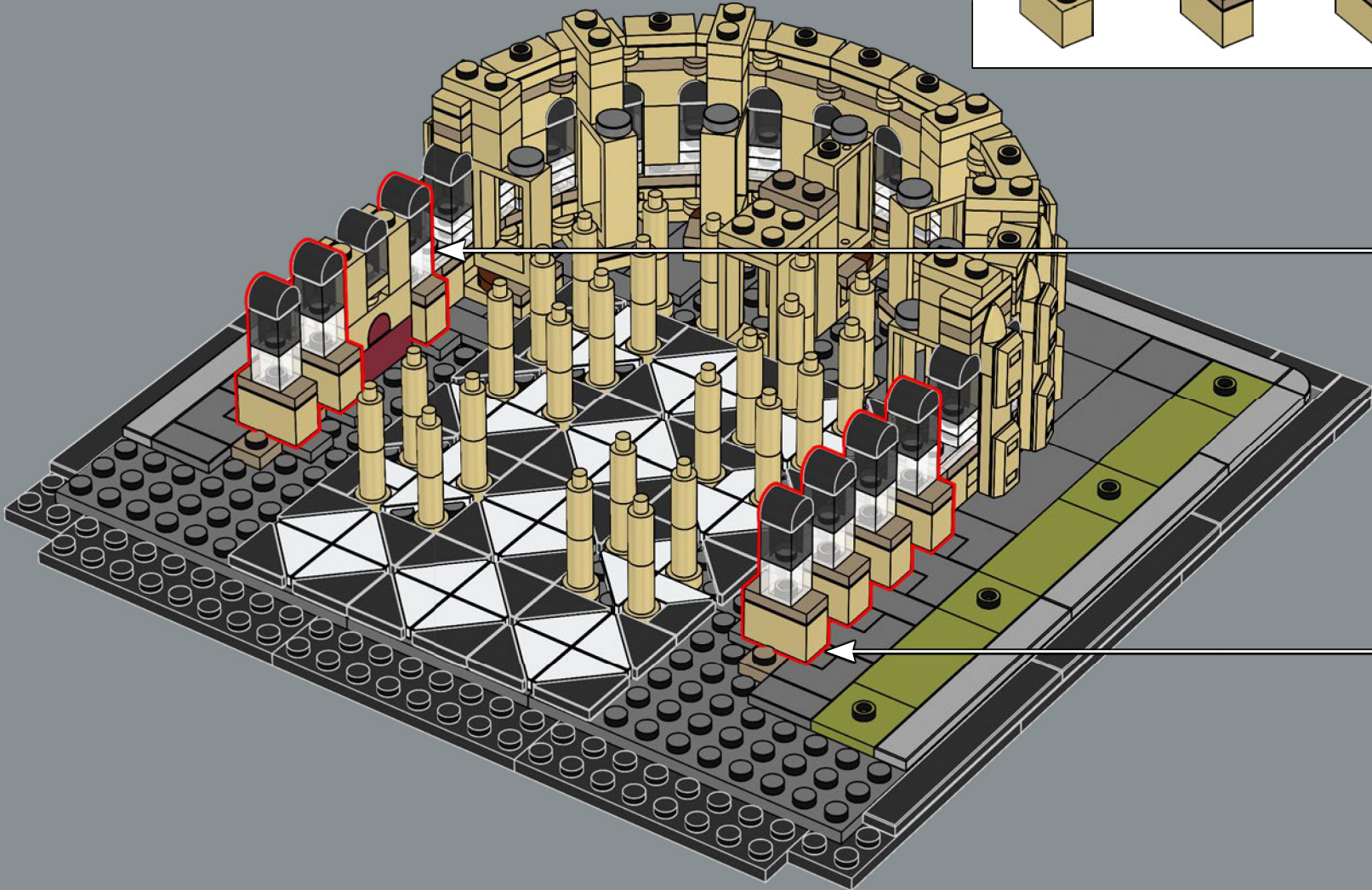
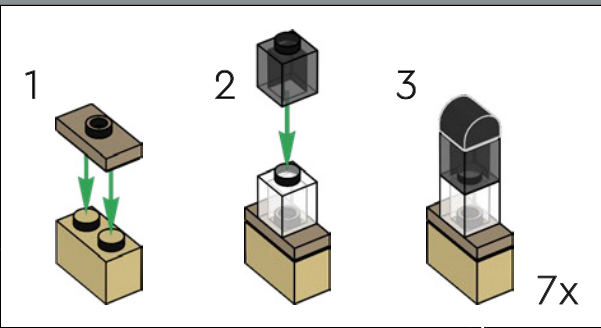

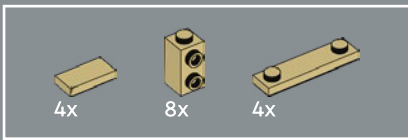

55

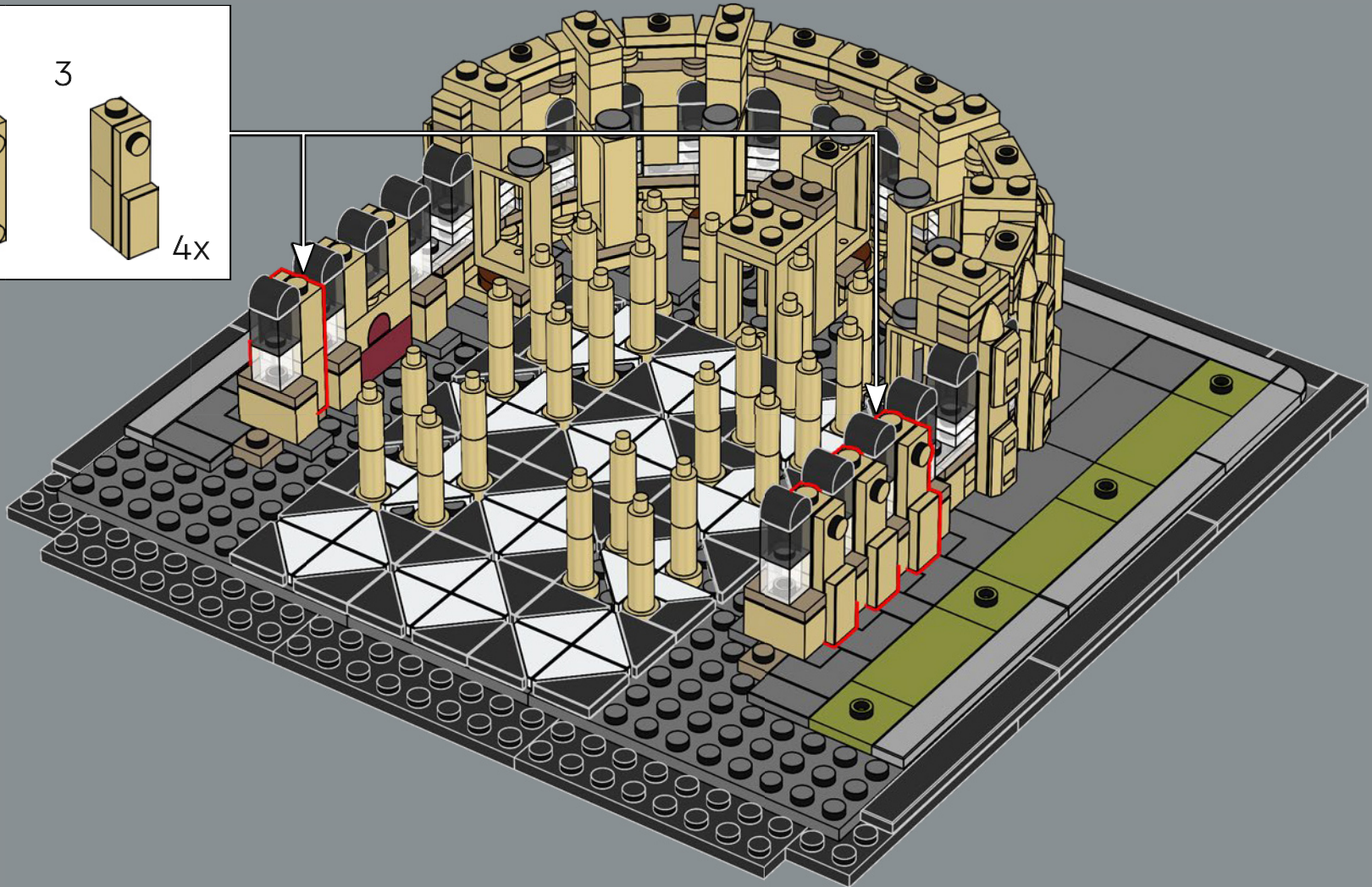
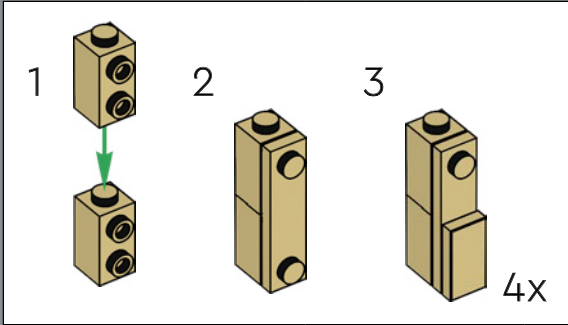

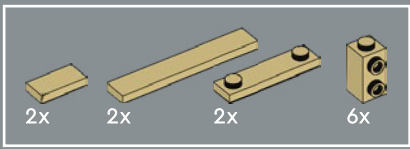

56

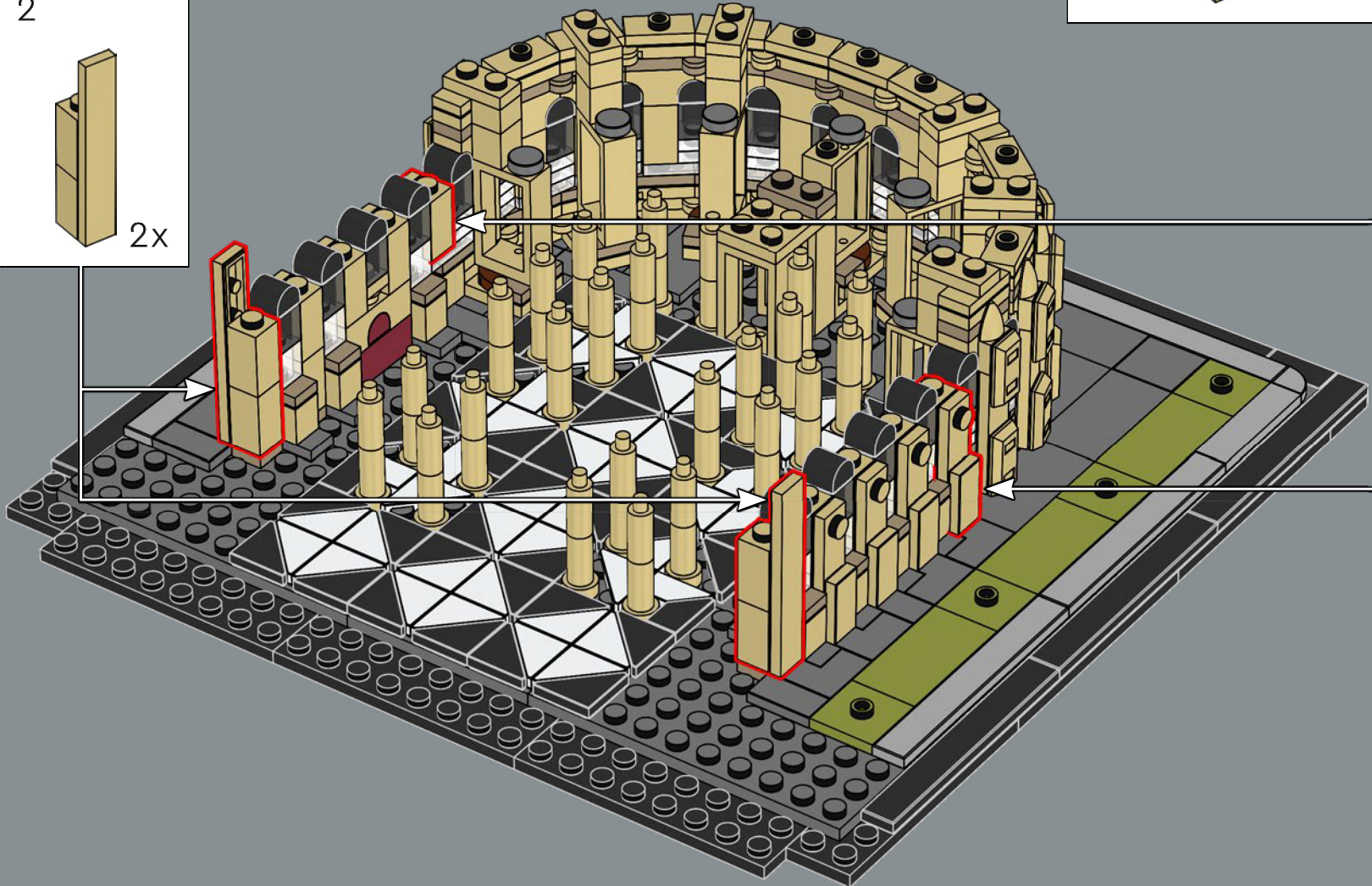
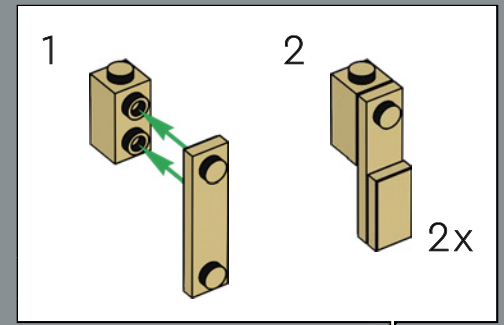
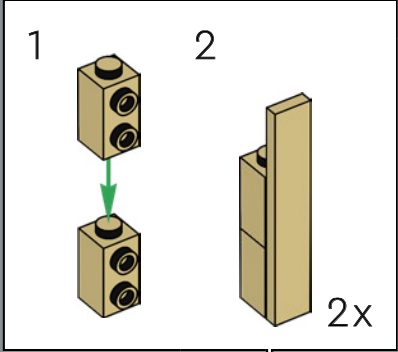

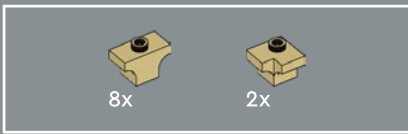

57

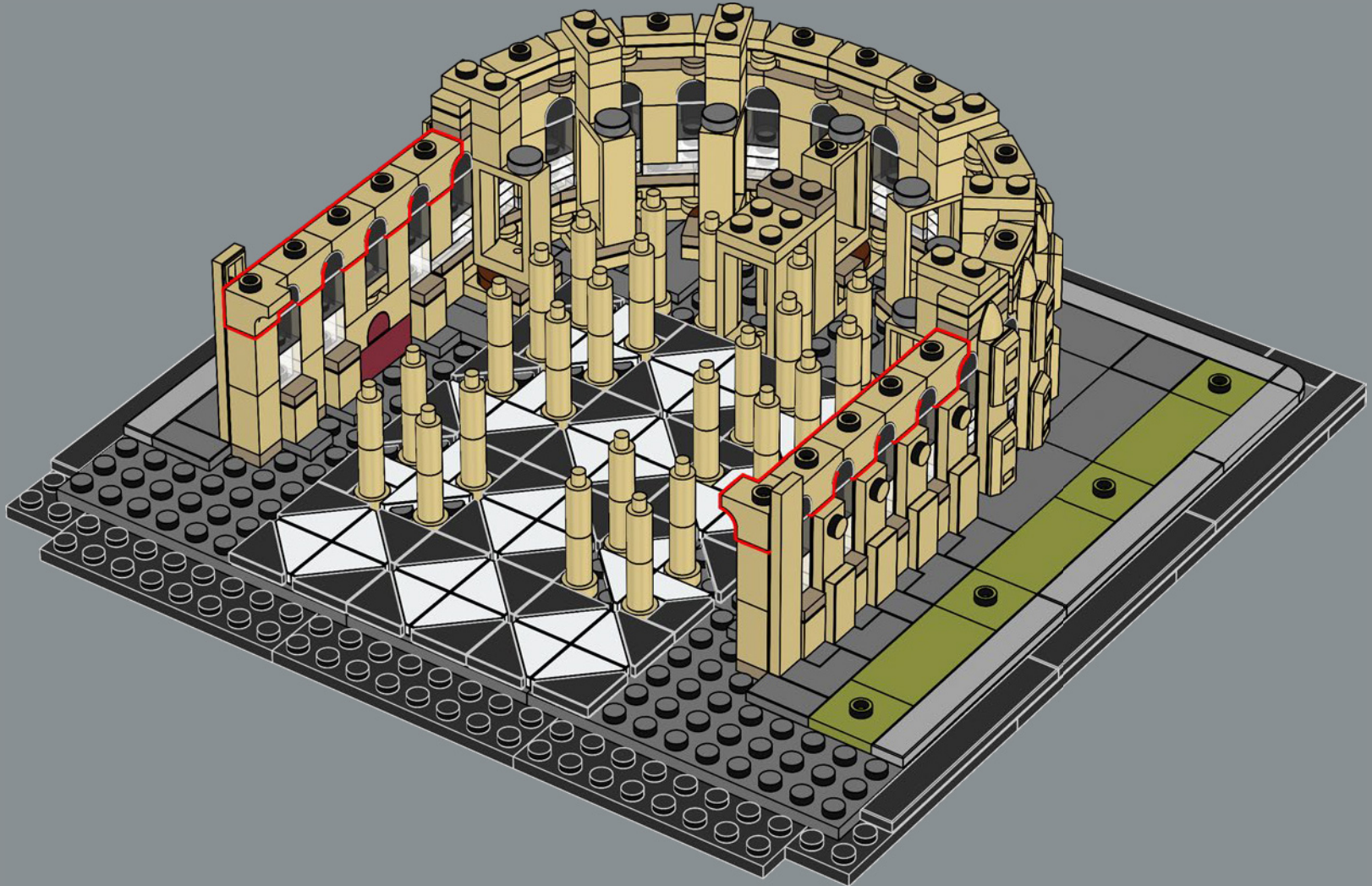

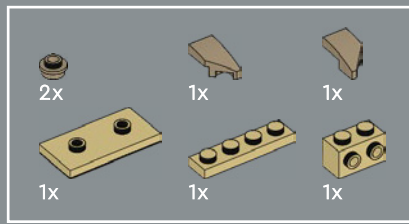

58

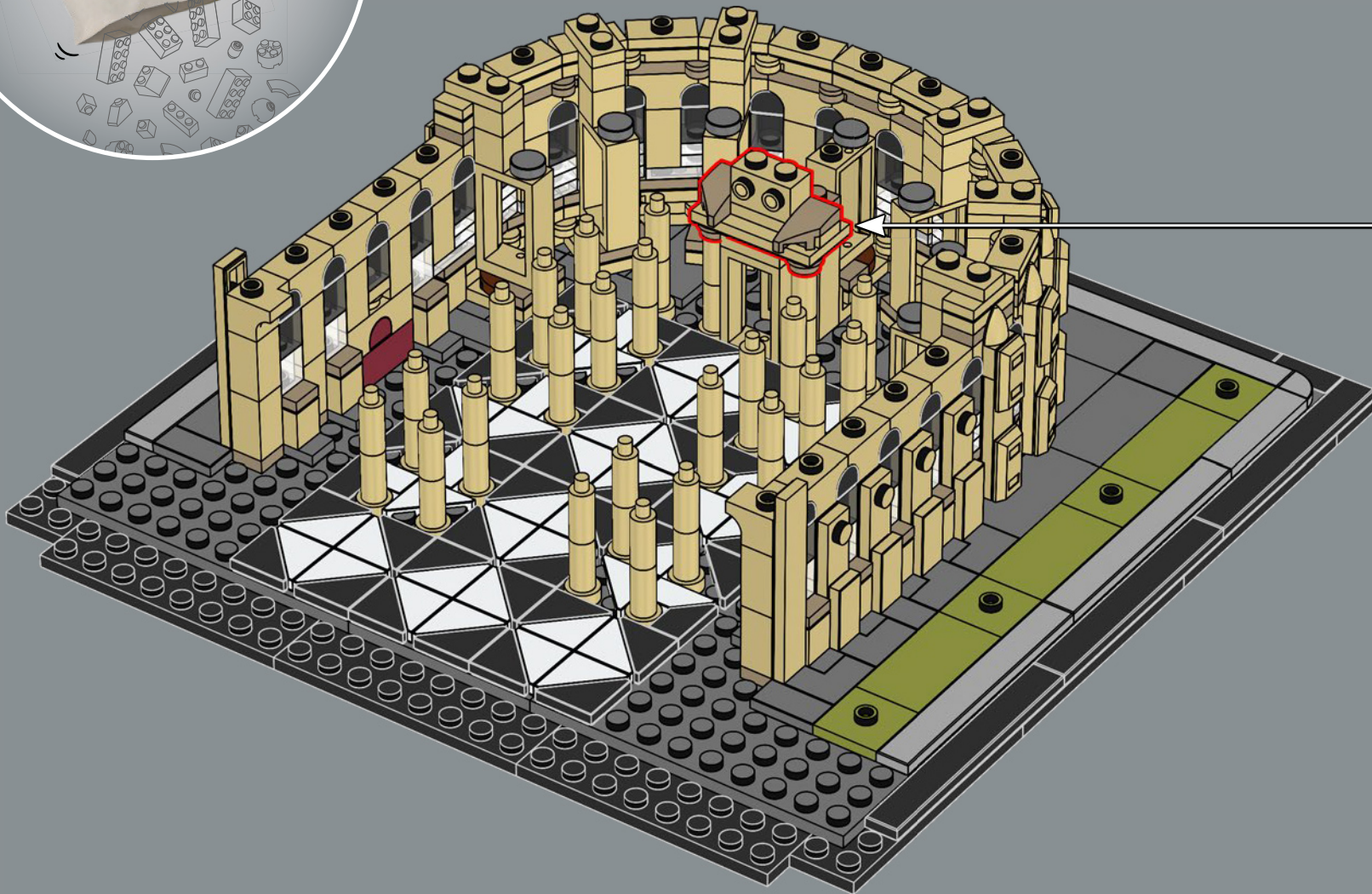
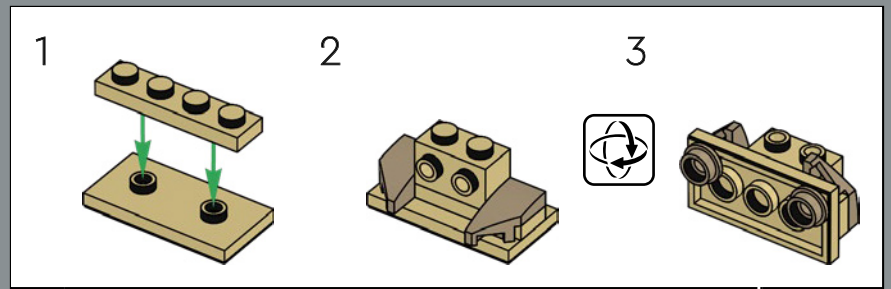

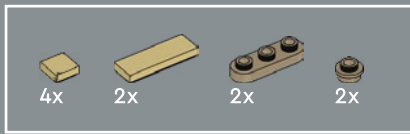

59

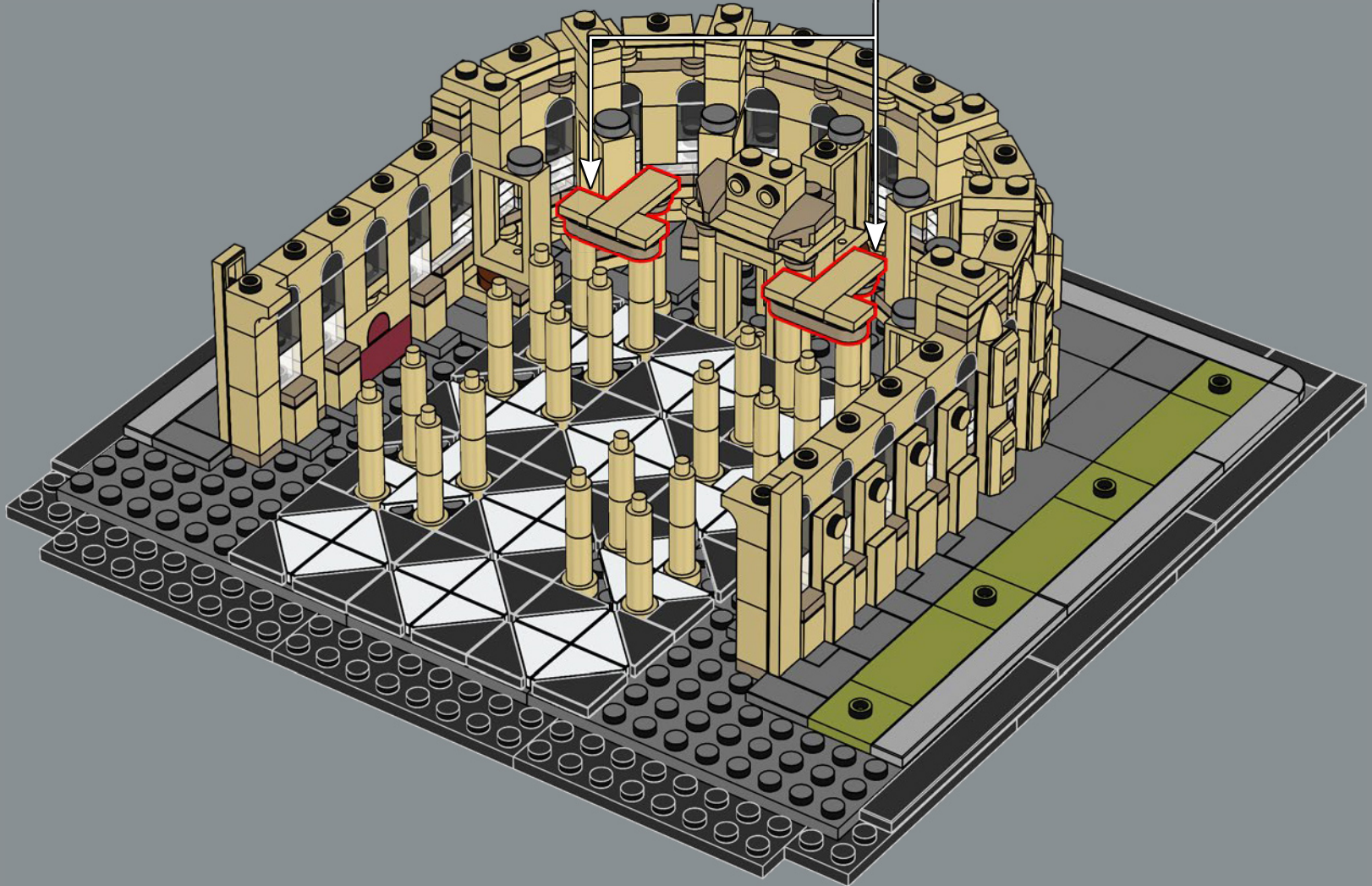
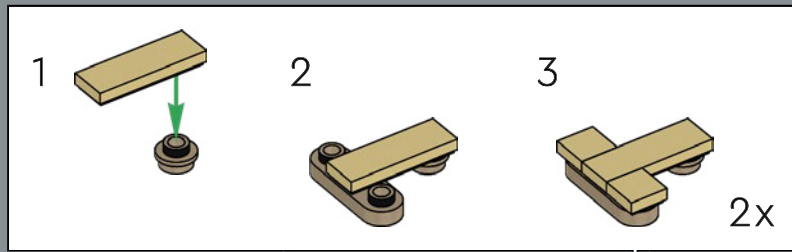

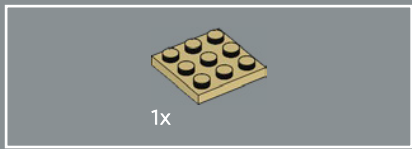

1x

60

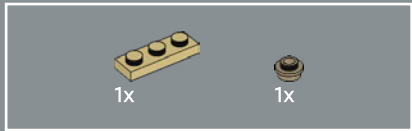

1x

1x

61

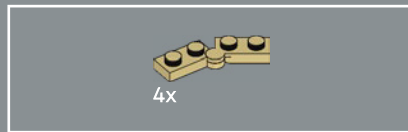
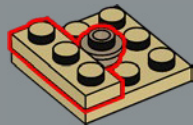

4x

62

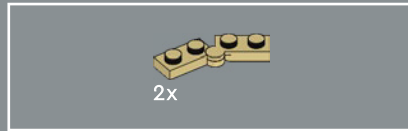
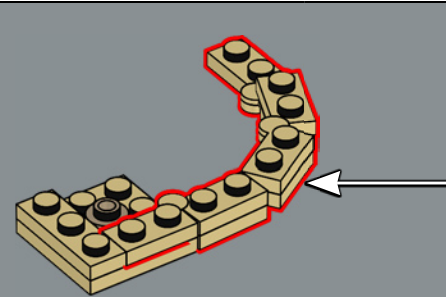
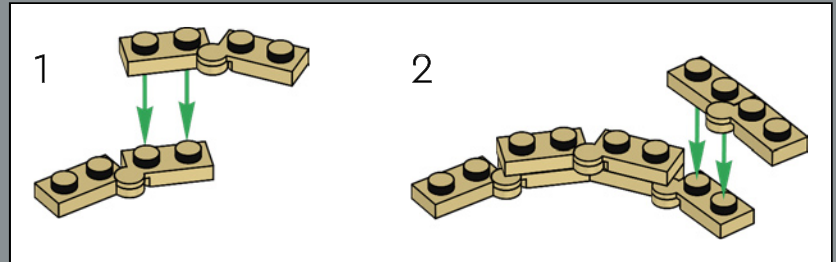

2x

63

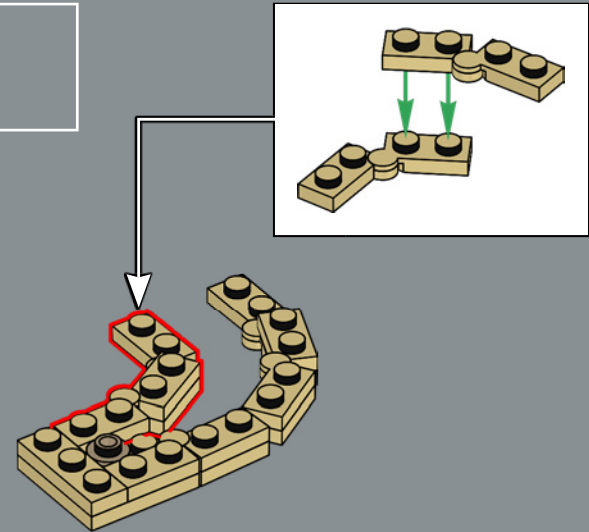



64

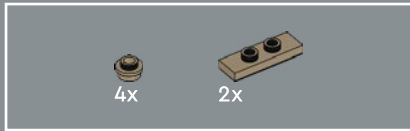
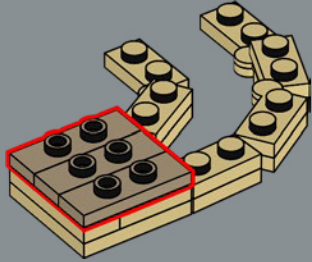

65

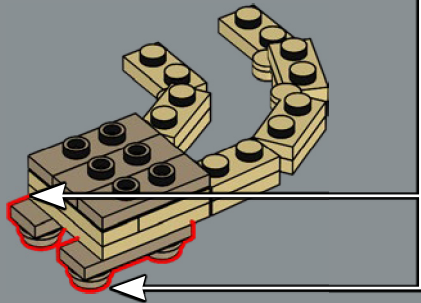
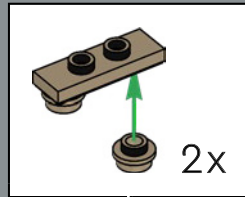

66

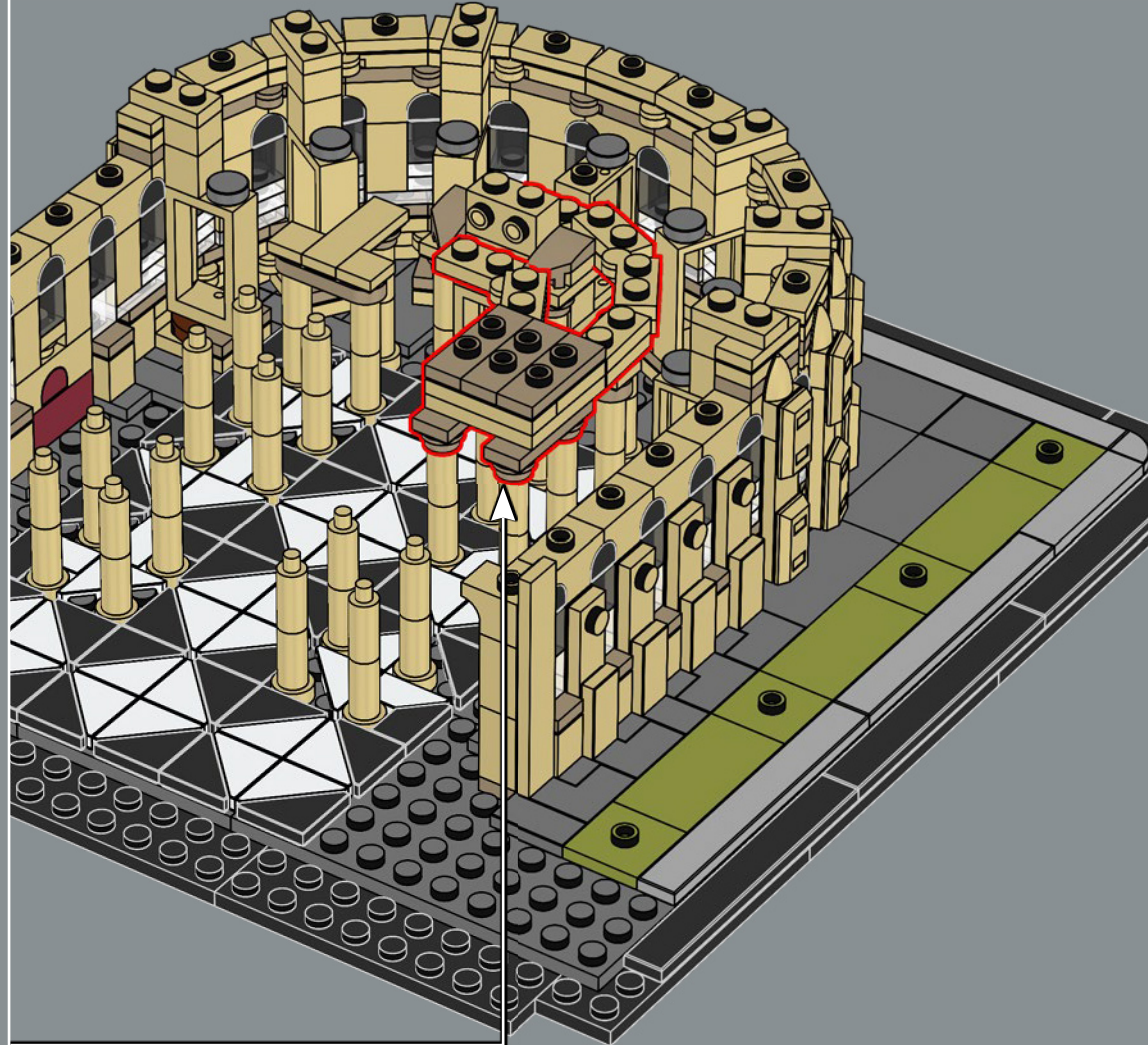

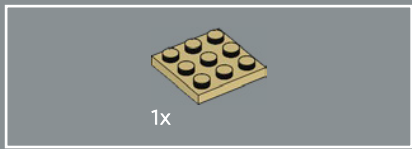

67

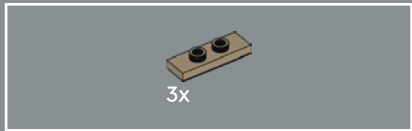

68

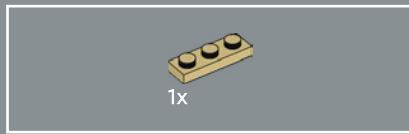
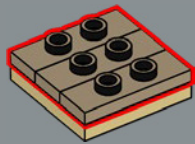

69

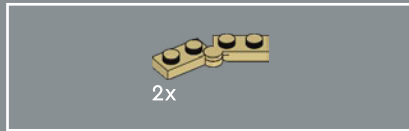
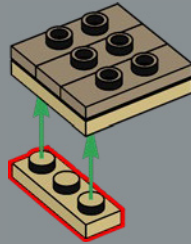

70

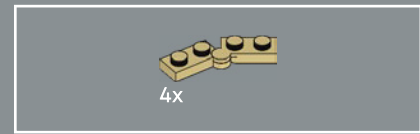
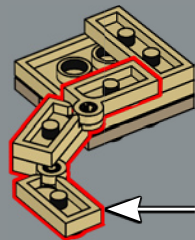
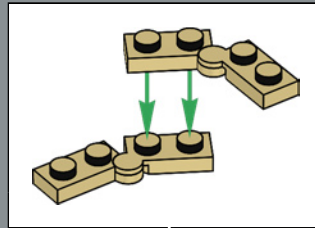

71

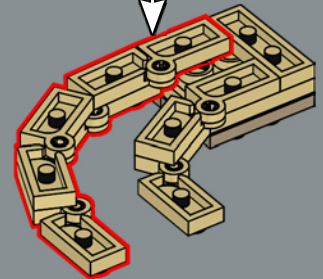
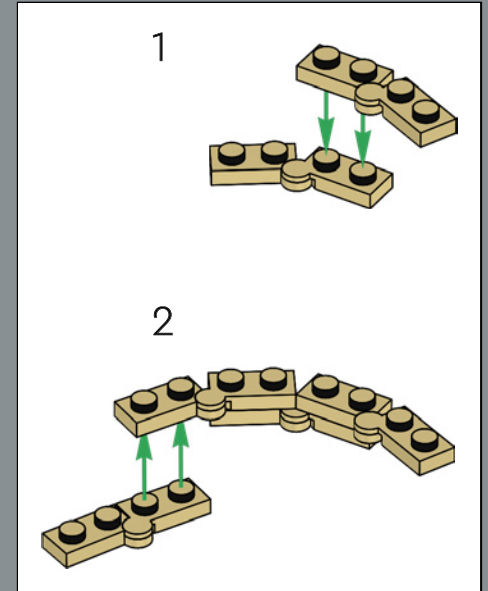

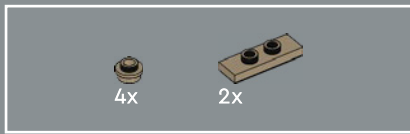

72

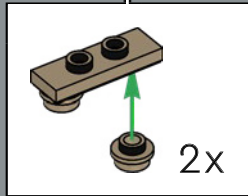
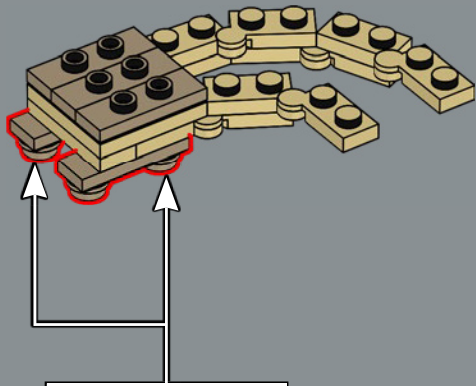

73

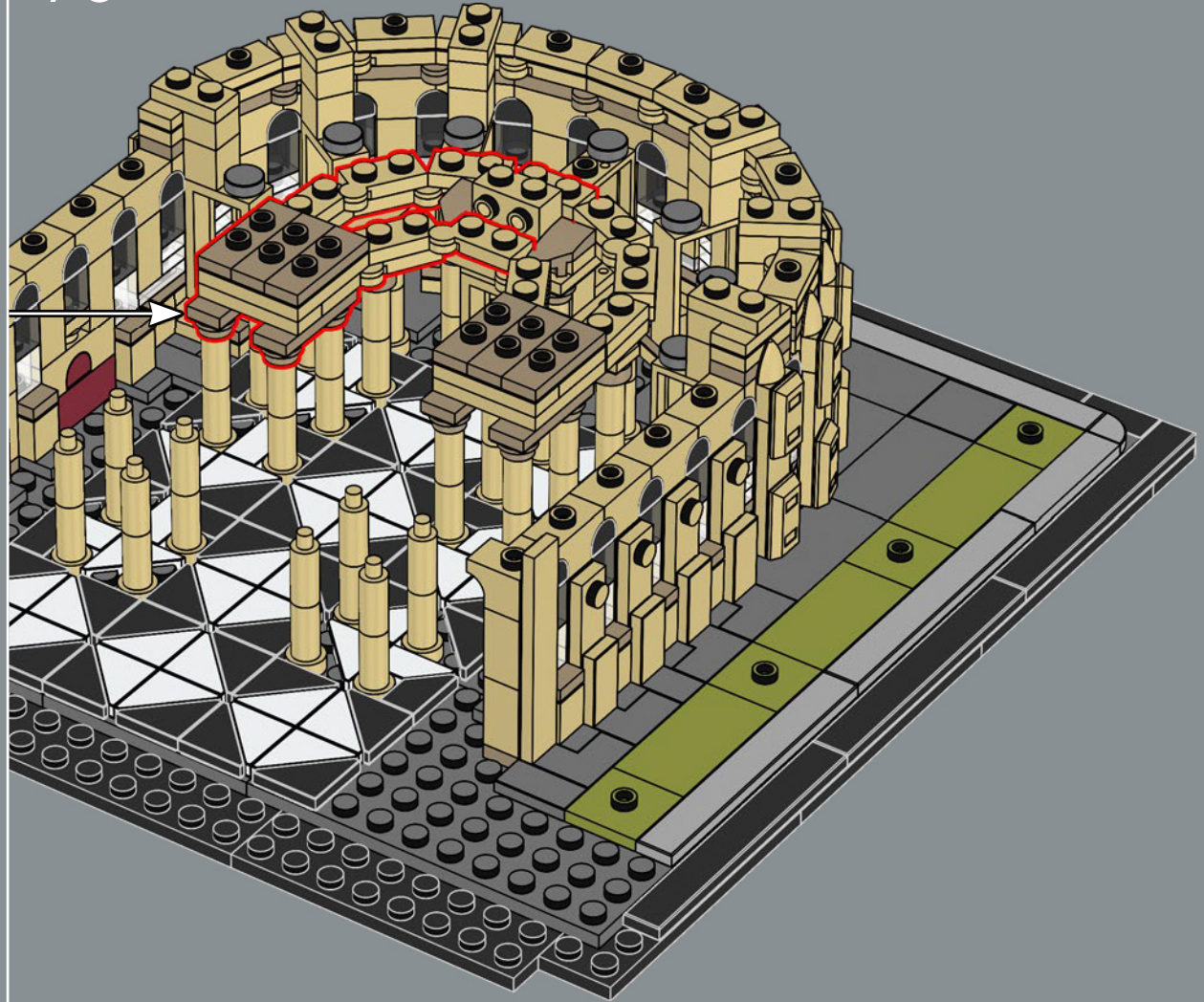

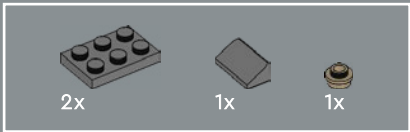

74

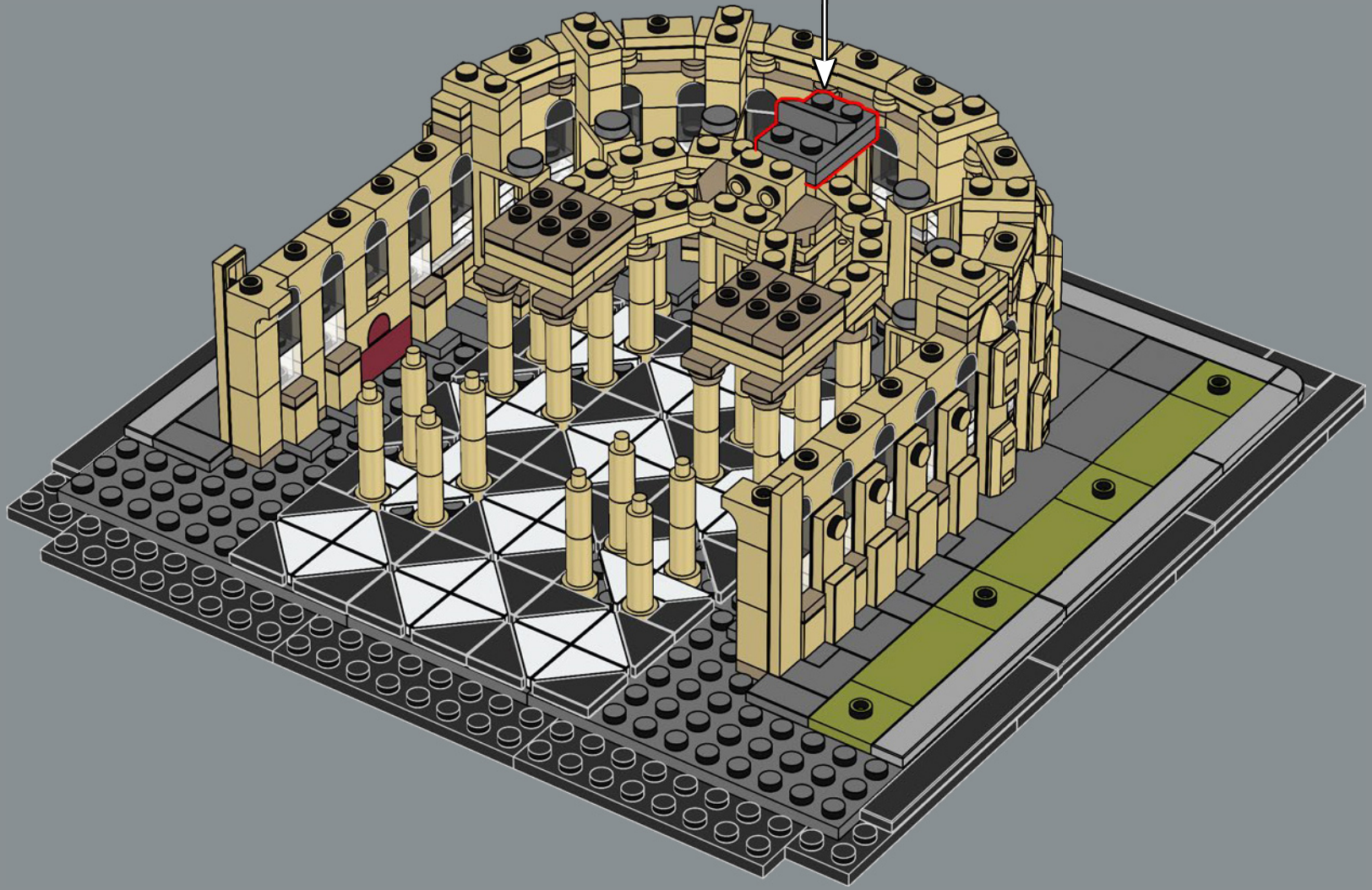
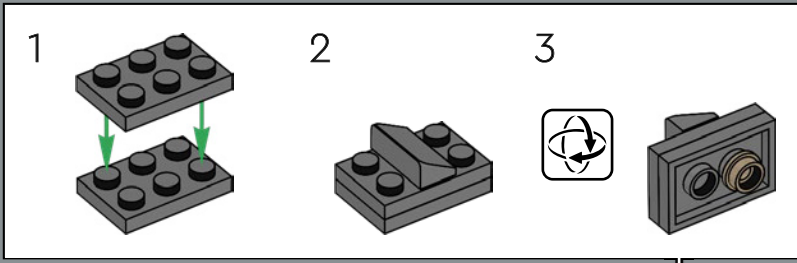

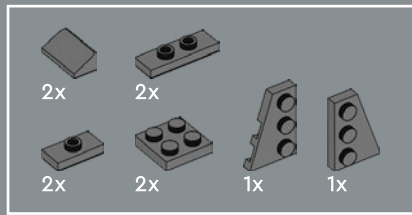

75

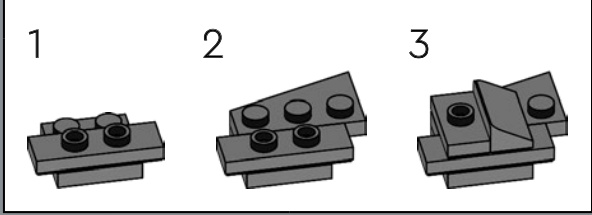
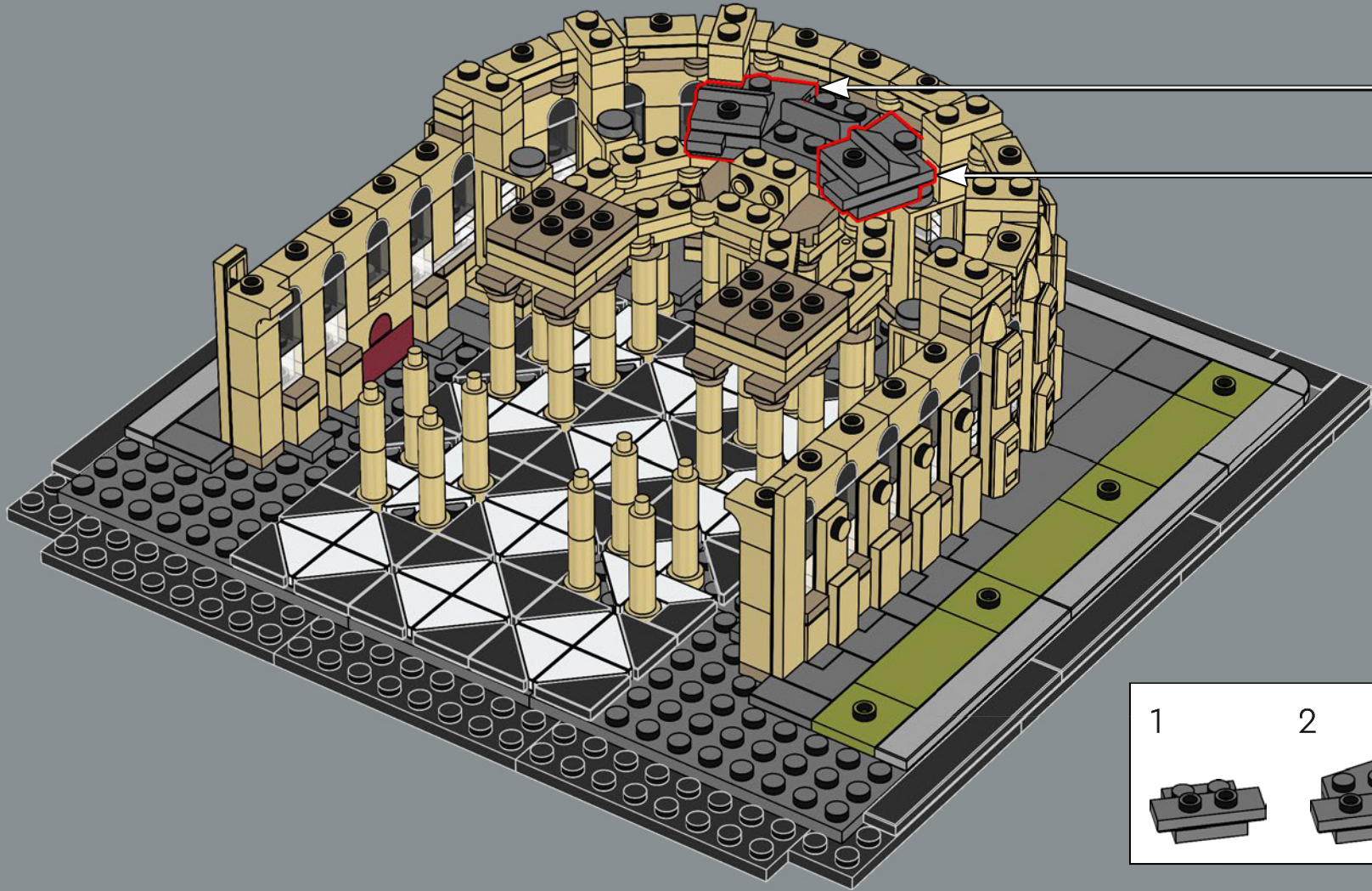
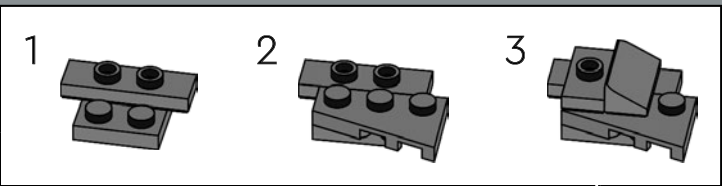

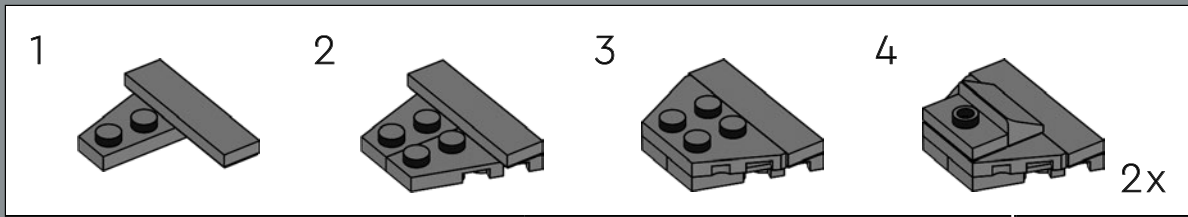
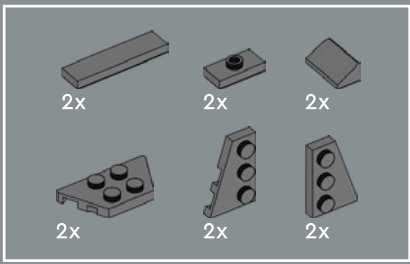

76

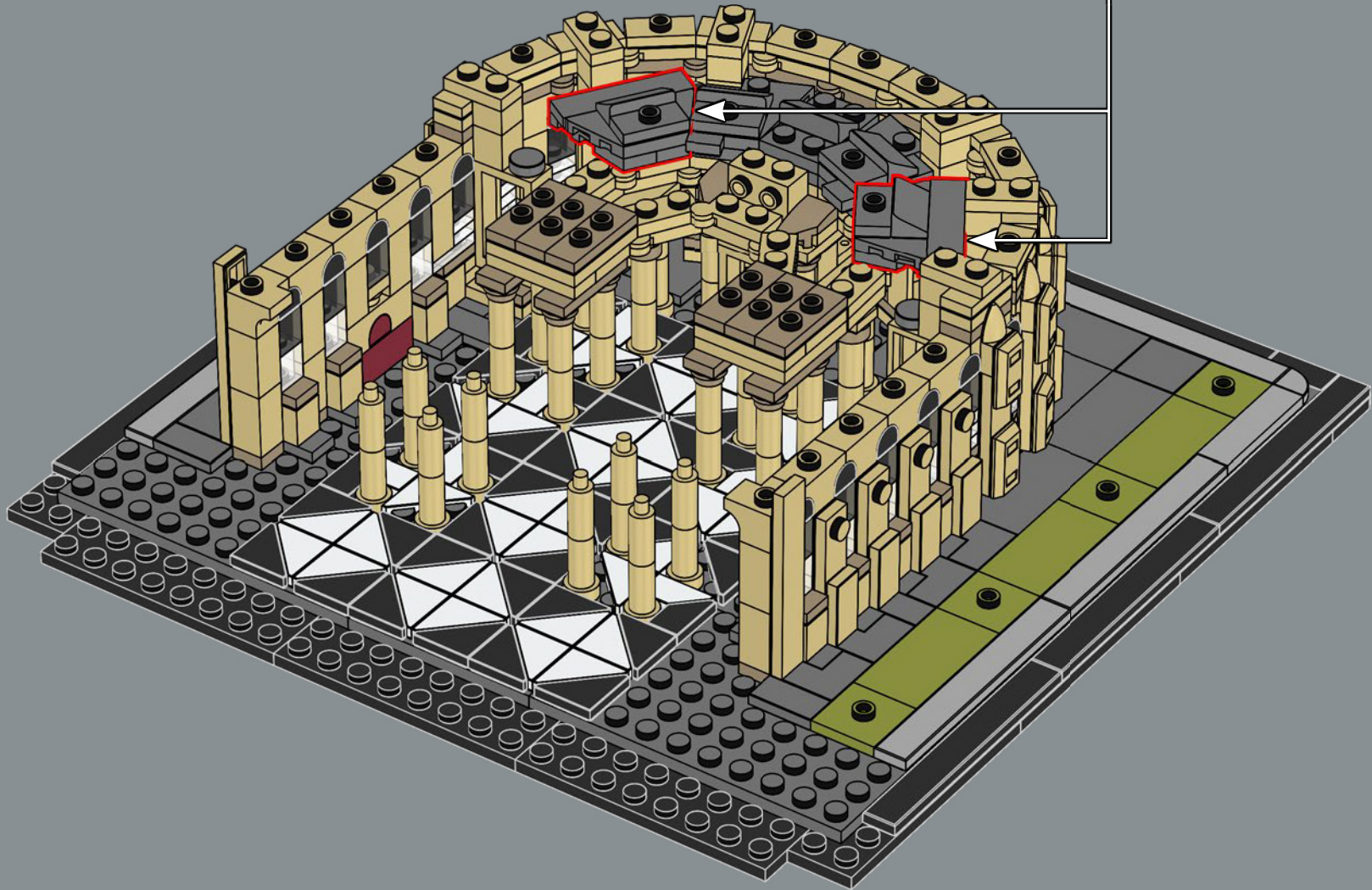

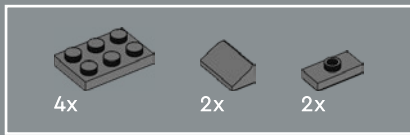

77

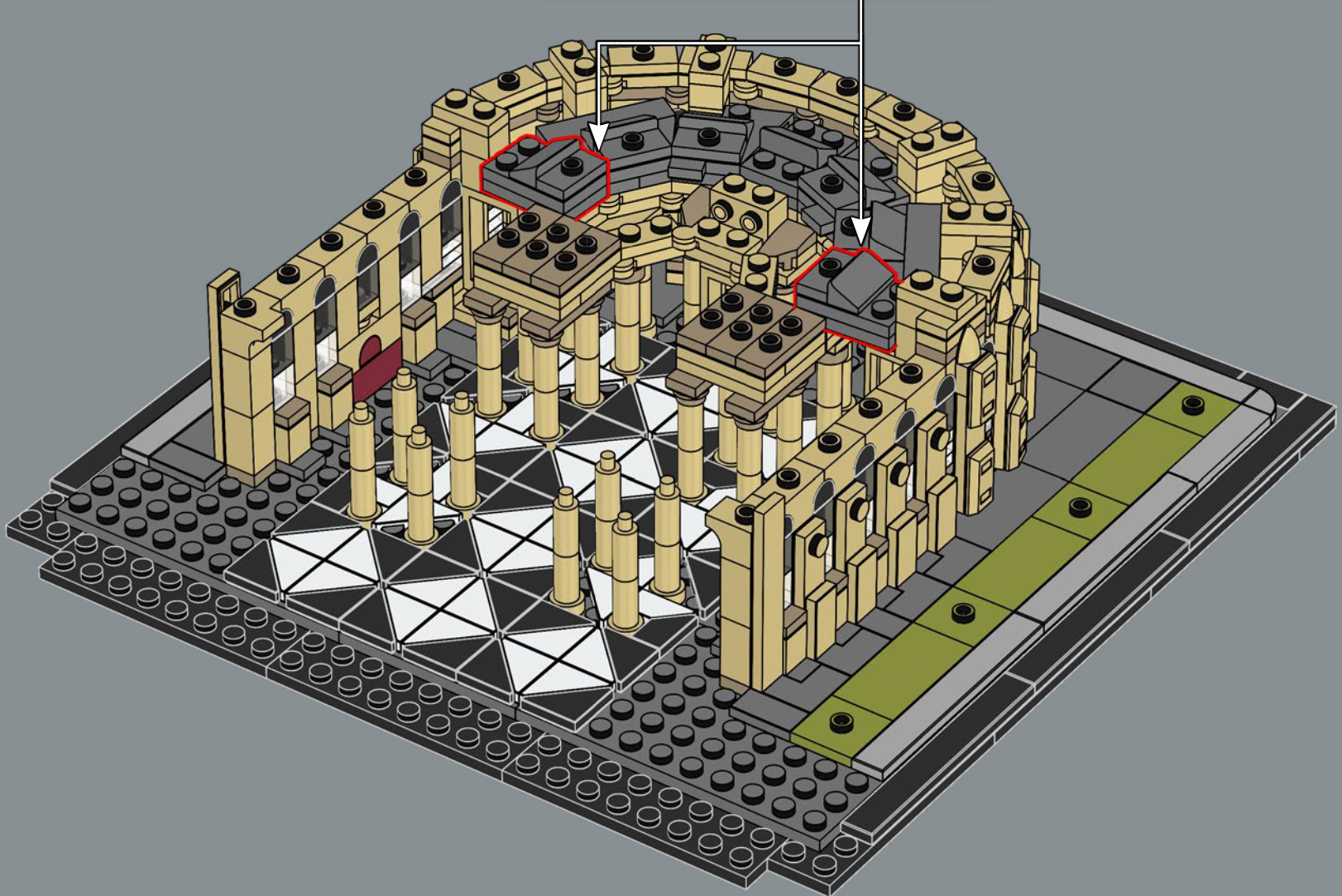
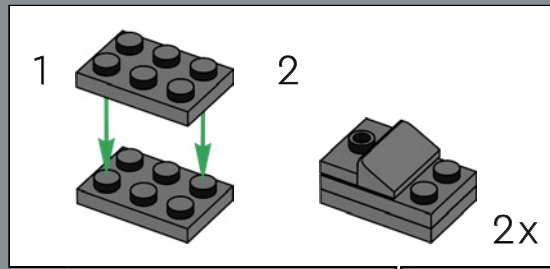



78

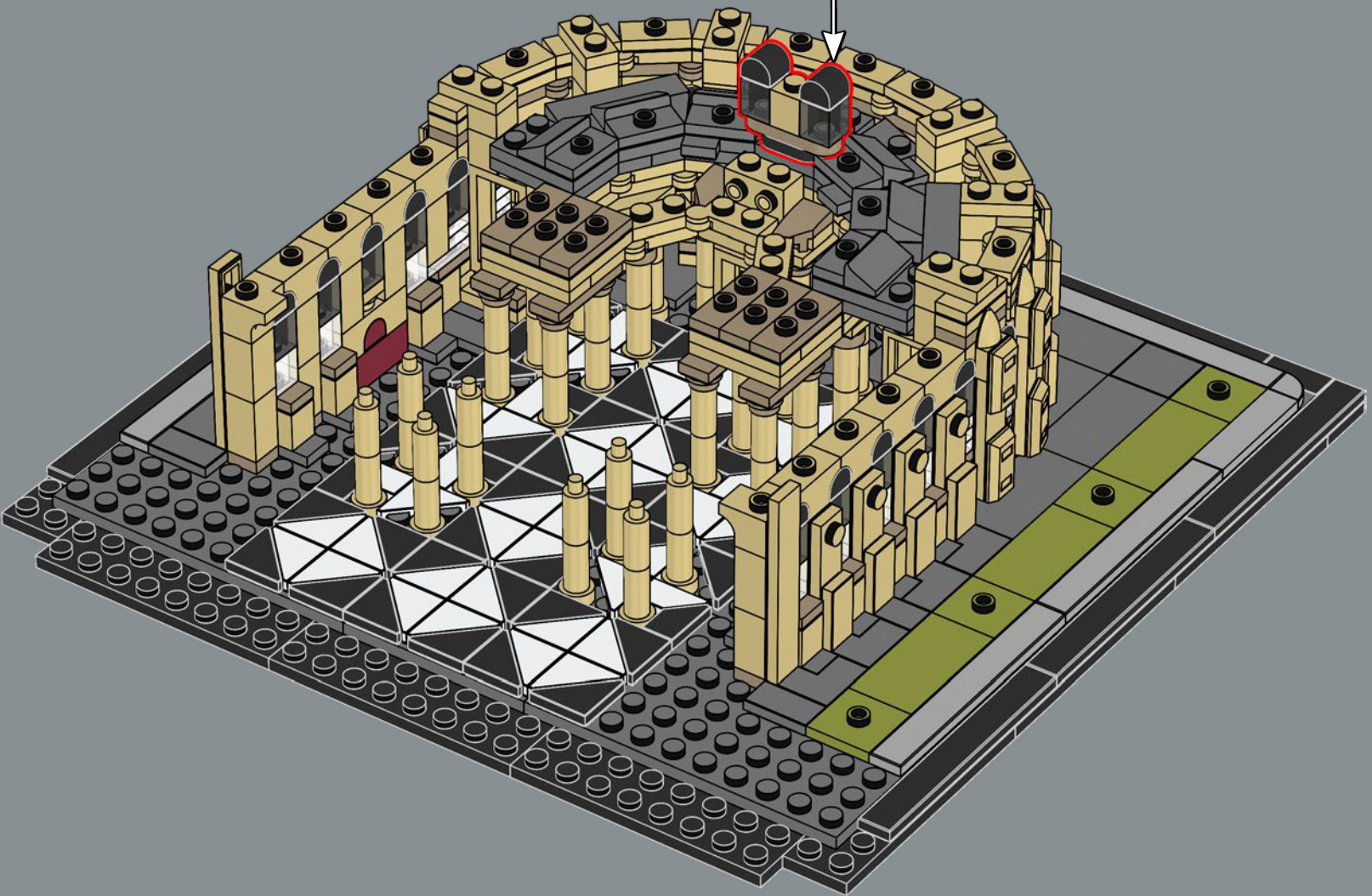
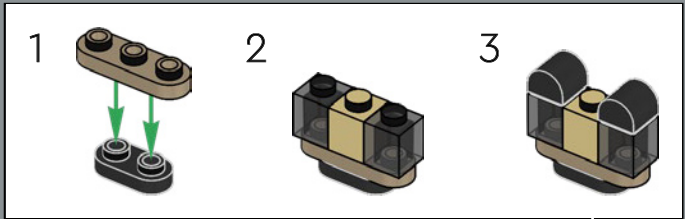



79

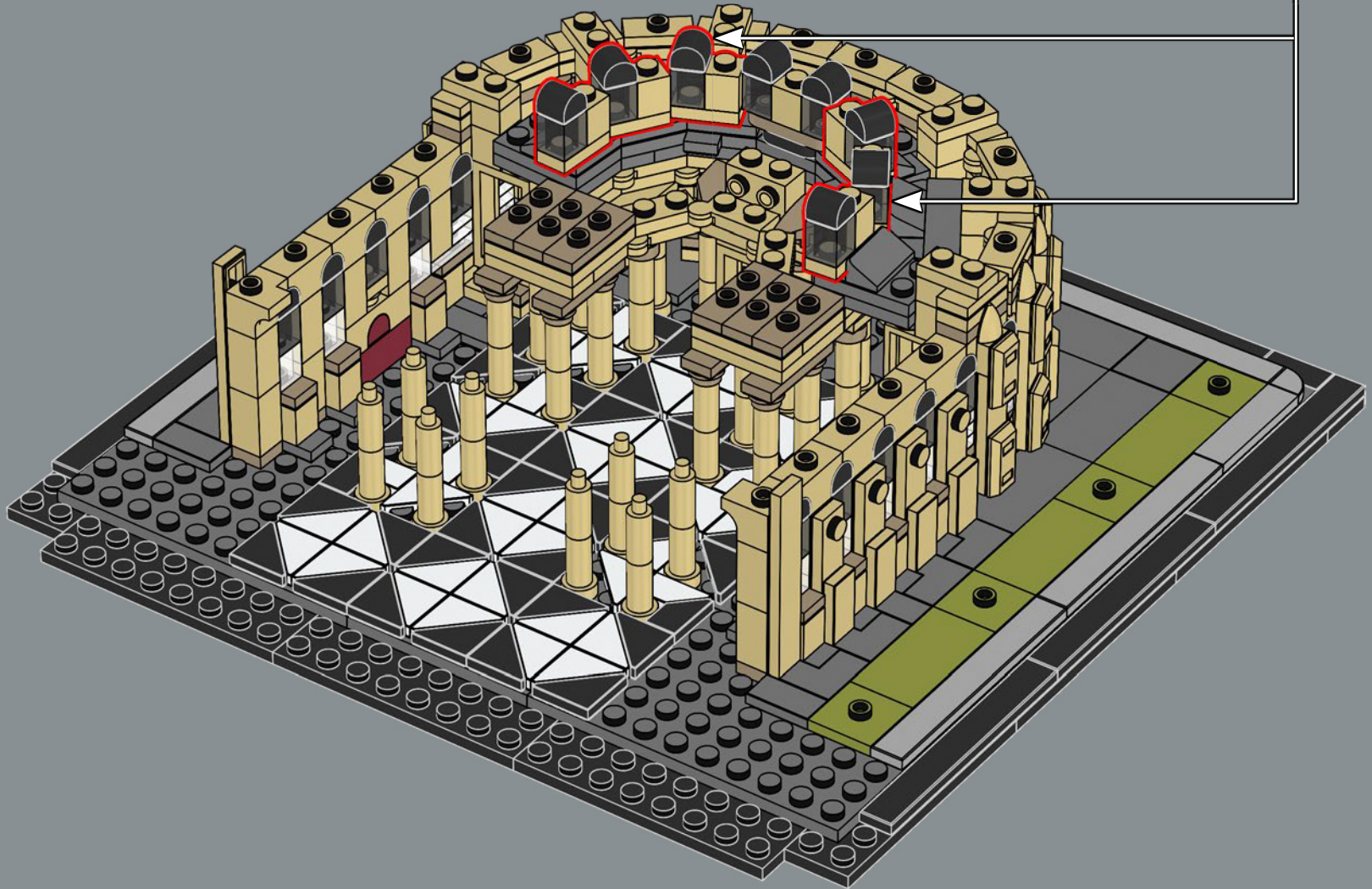
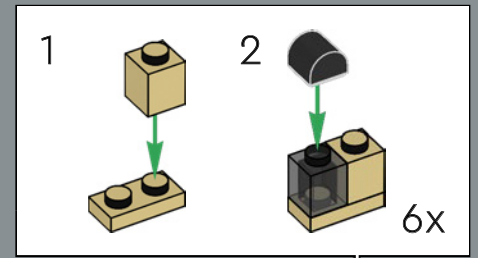



7x

80

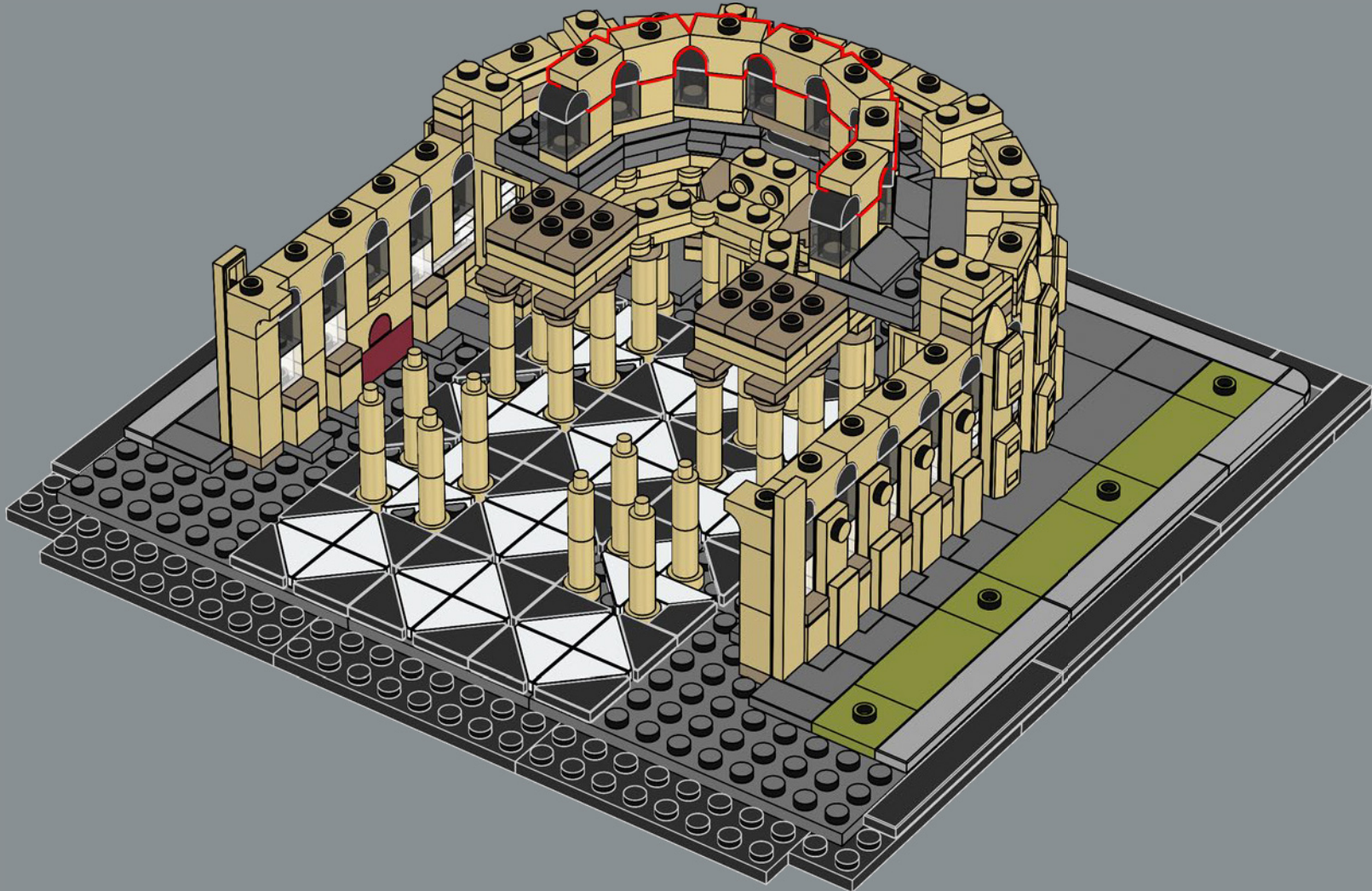

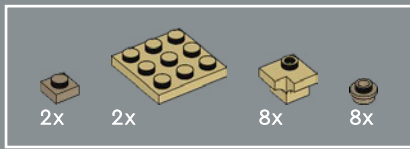

81

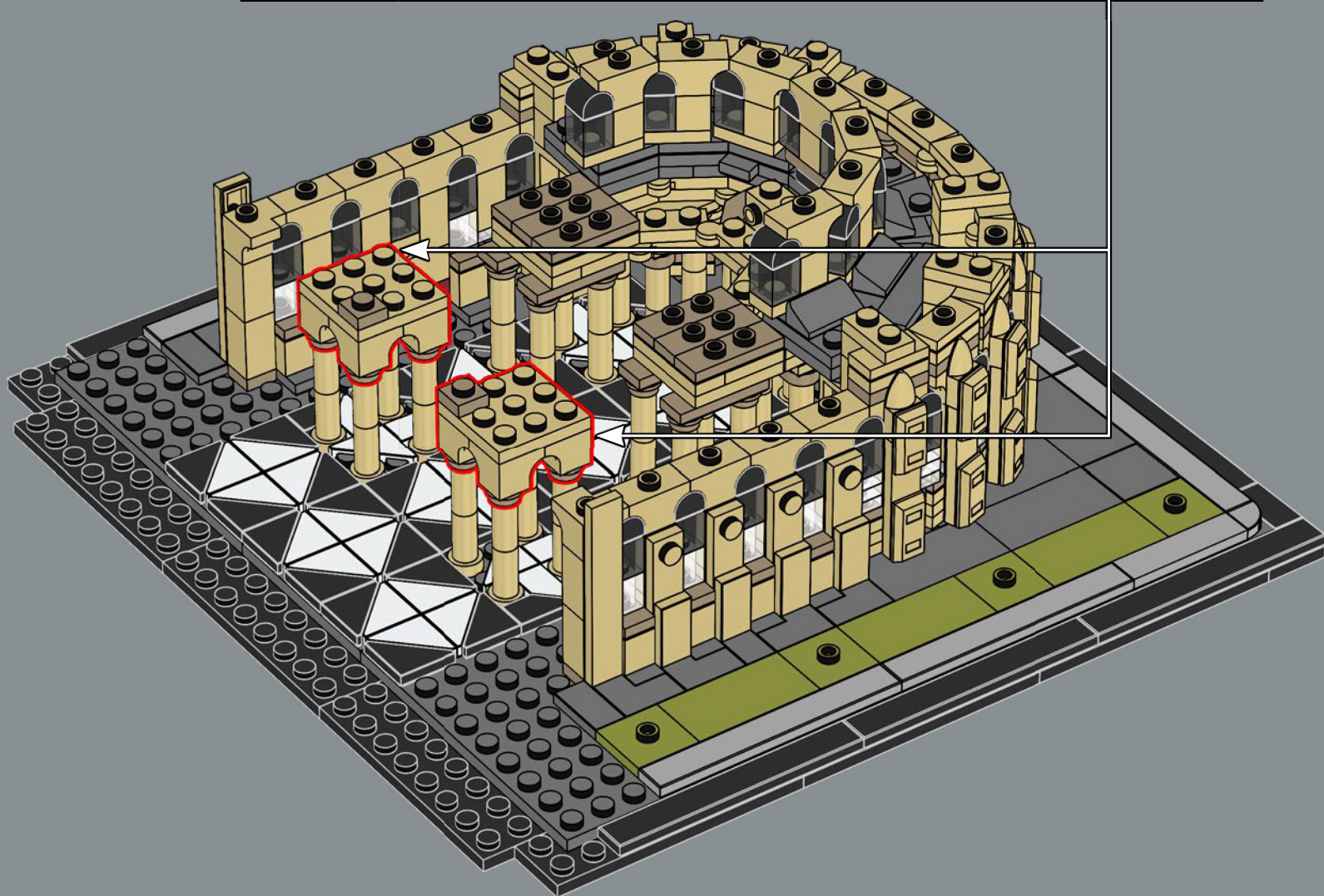
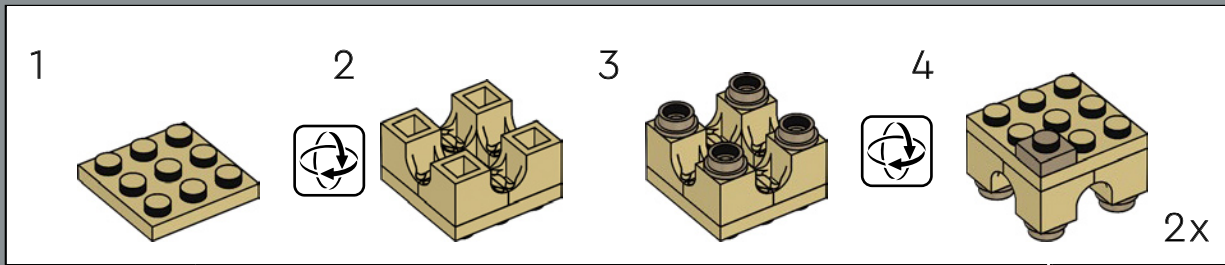

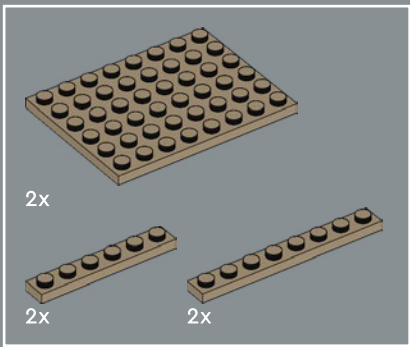

82

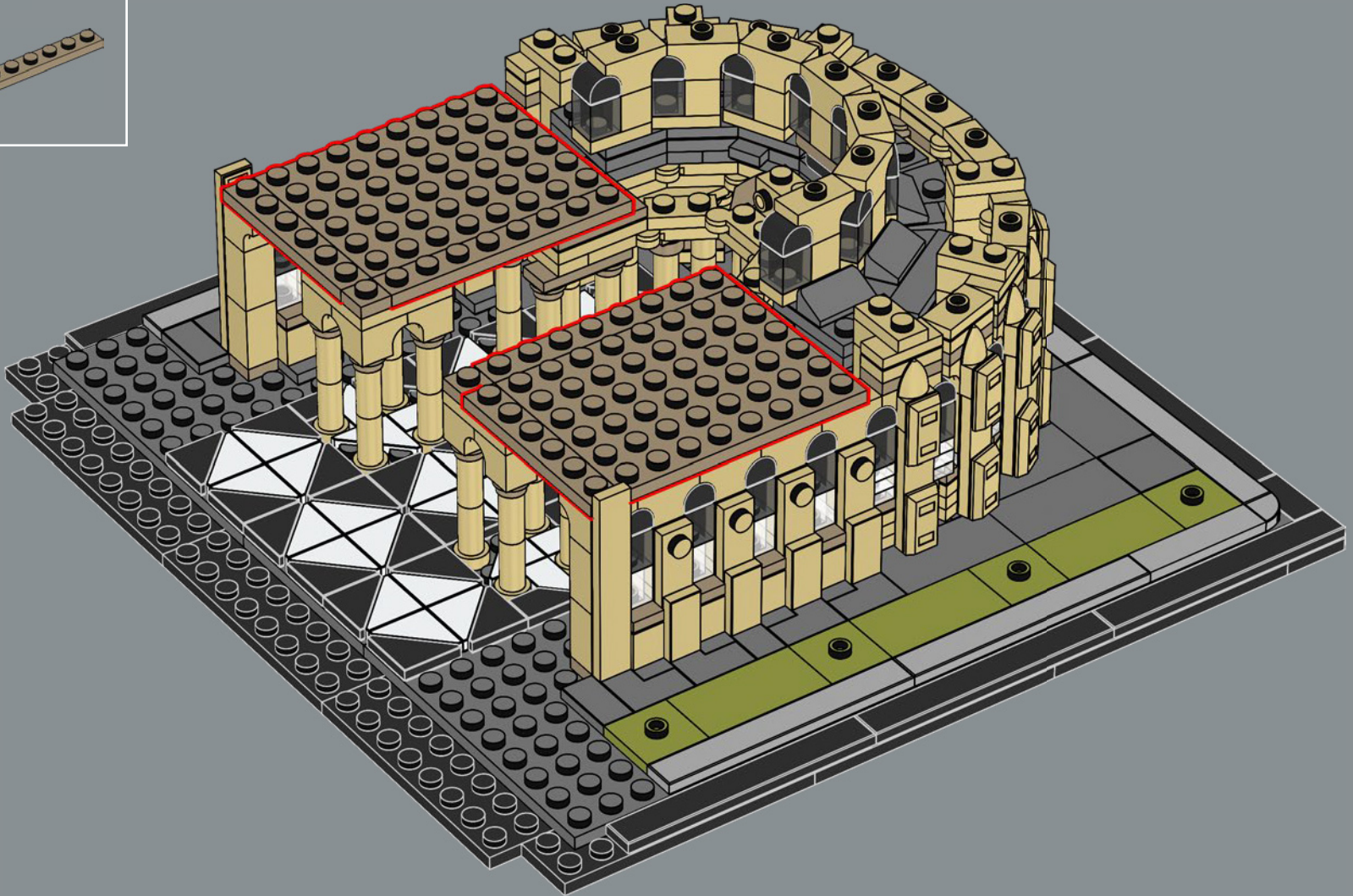



83

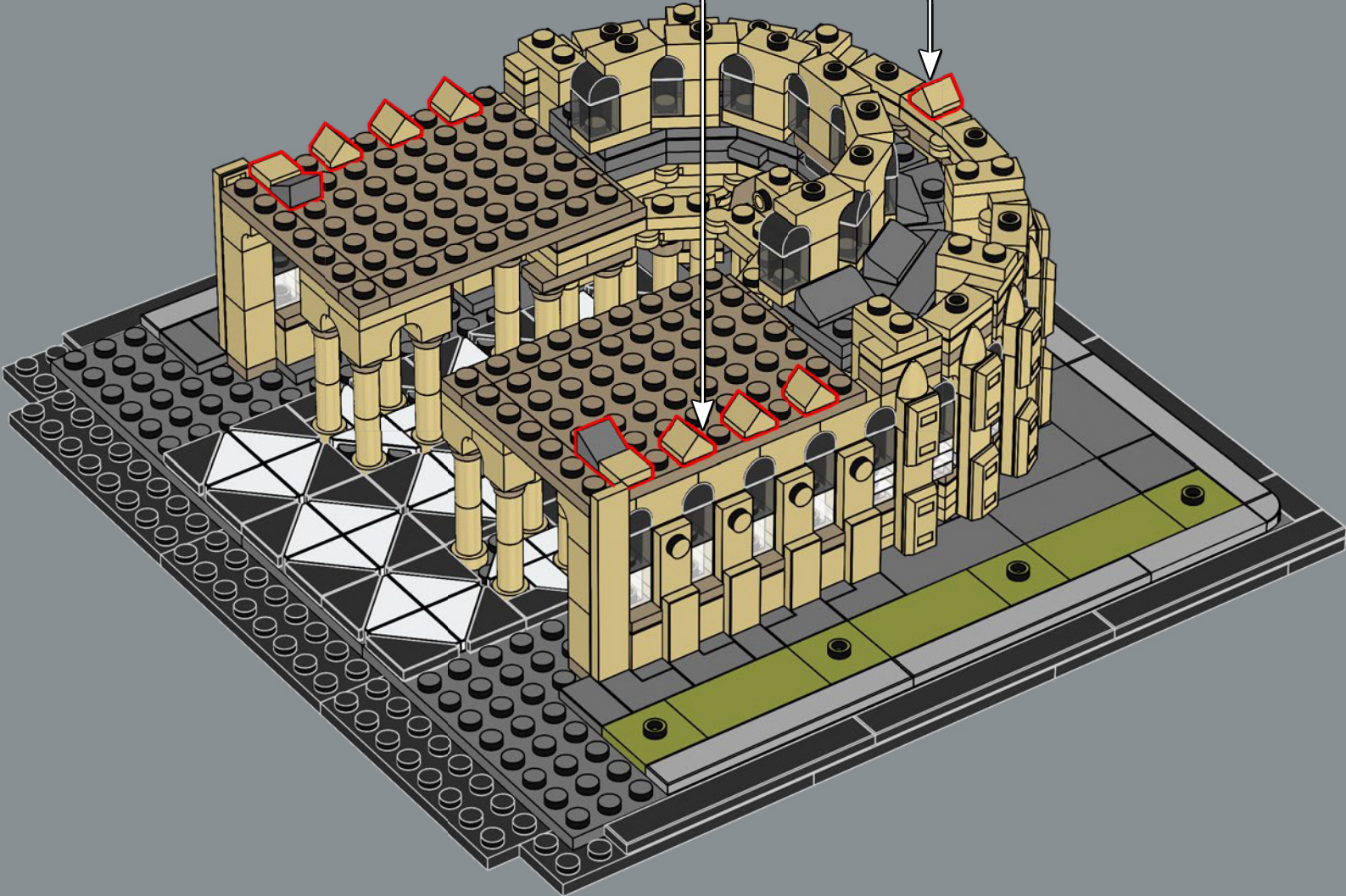

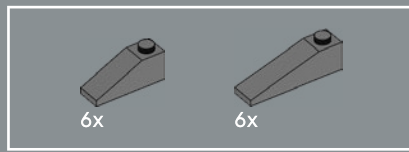

84

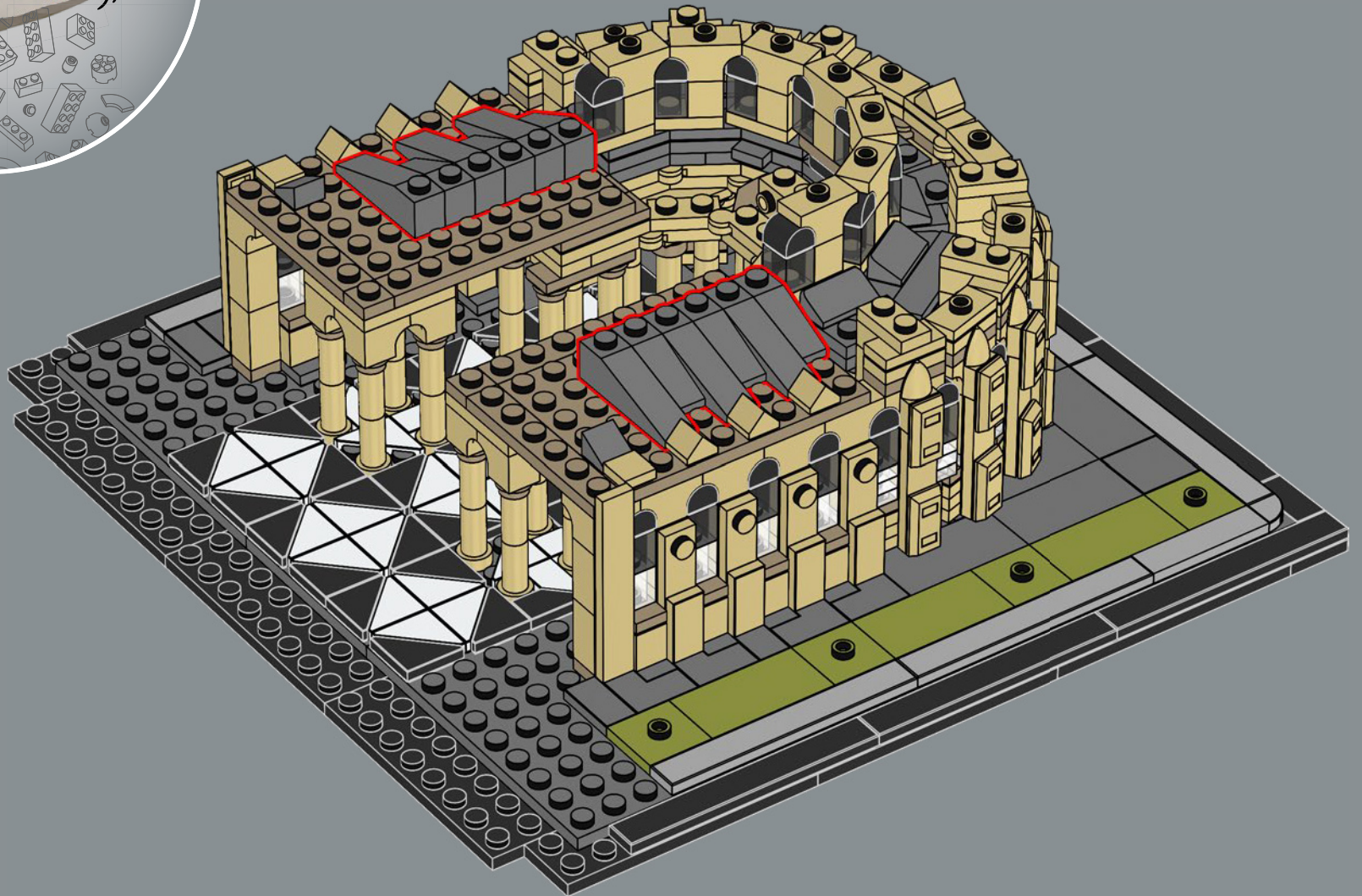

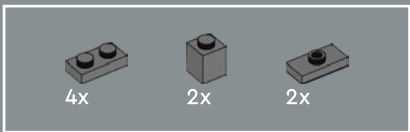

85

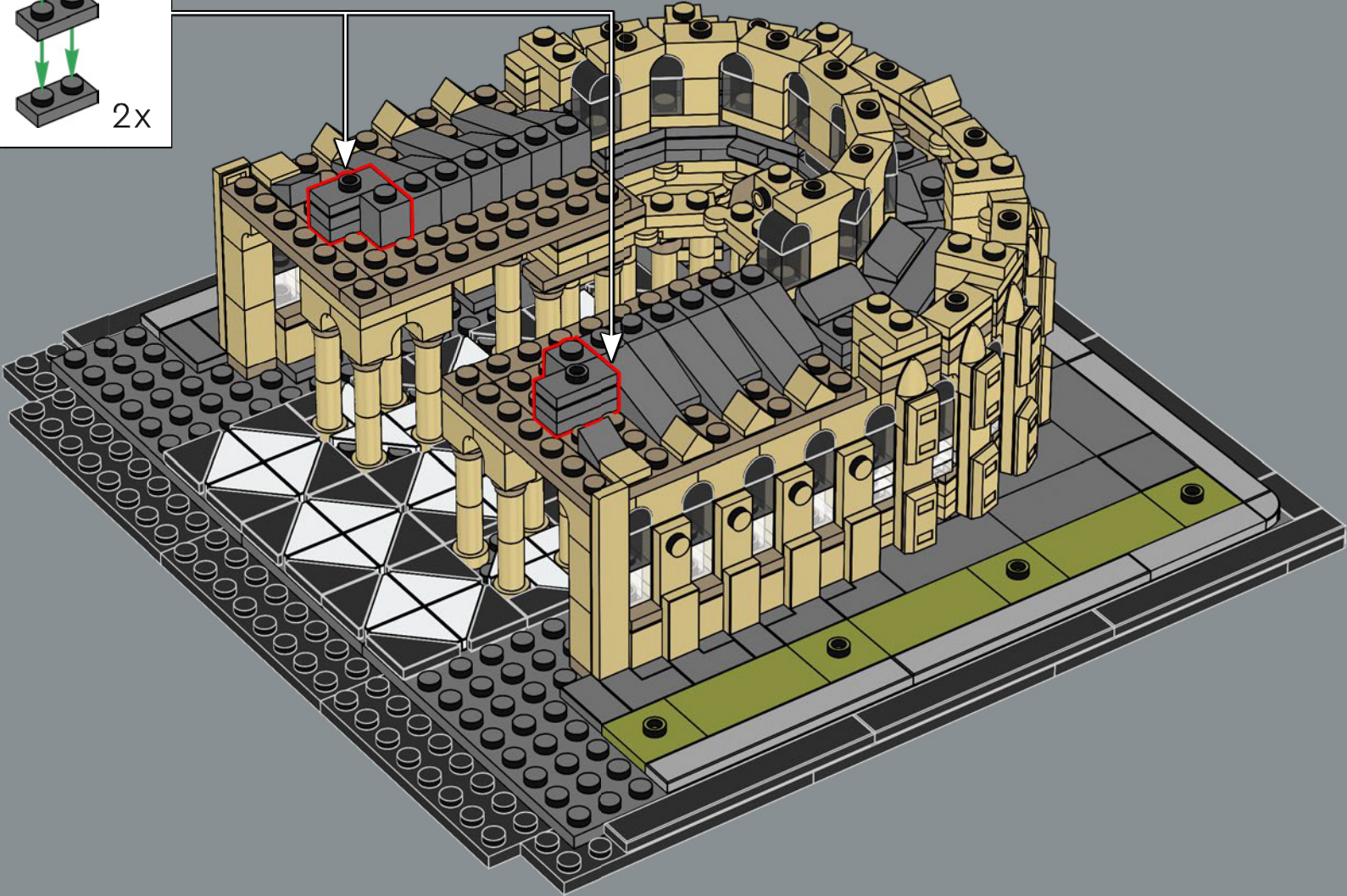
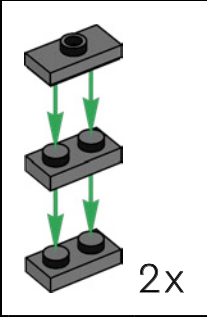



12x

86

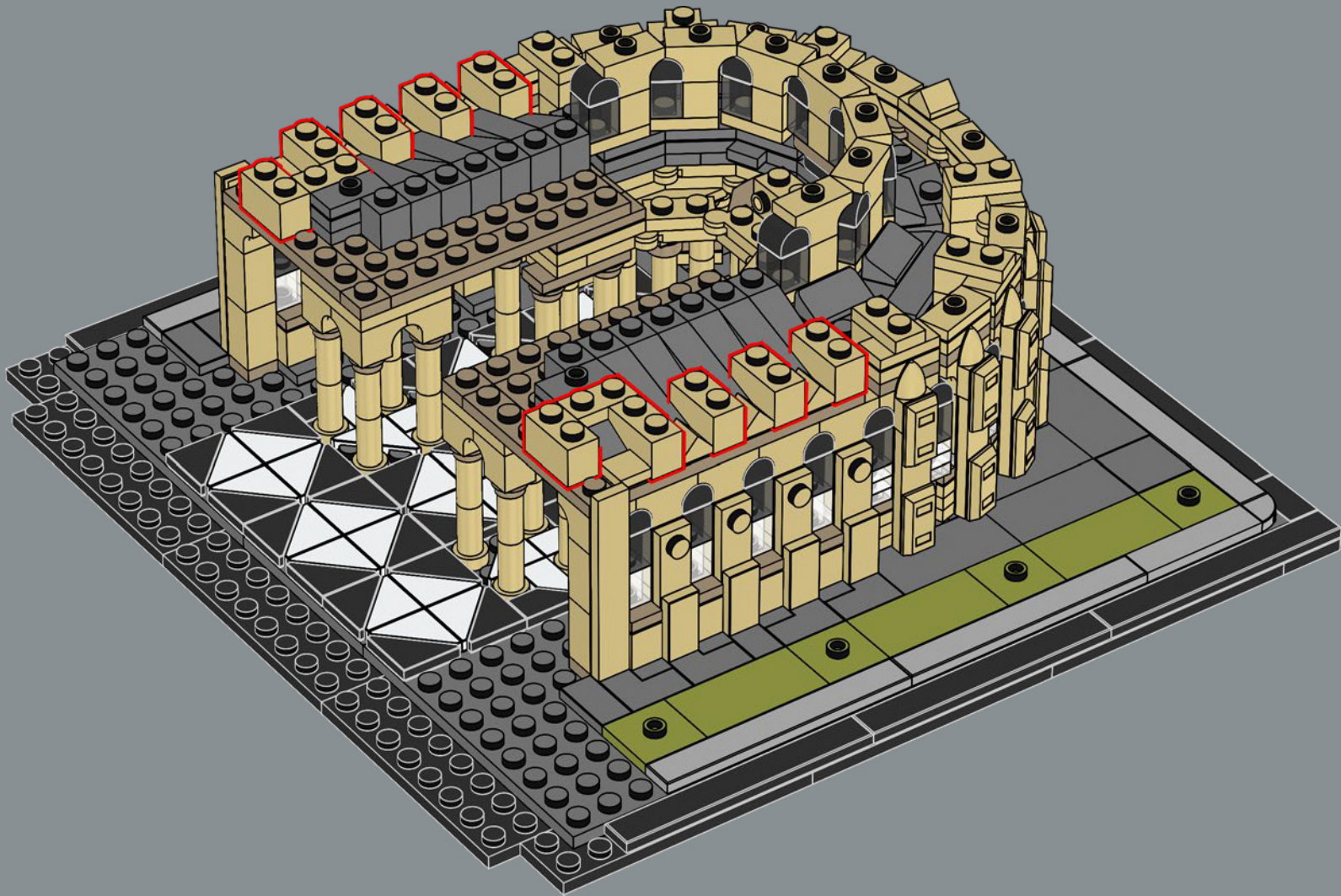

- 
8x
- 
8x
- 
2x
- 
14x
- 
8x

87

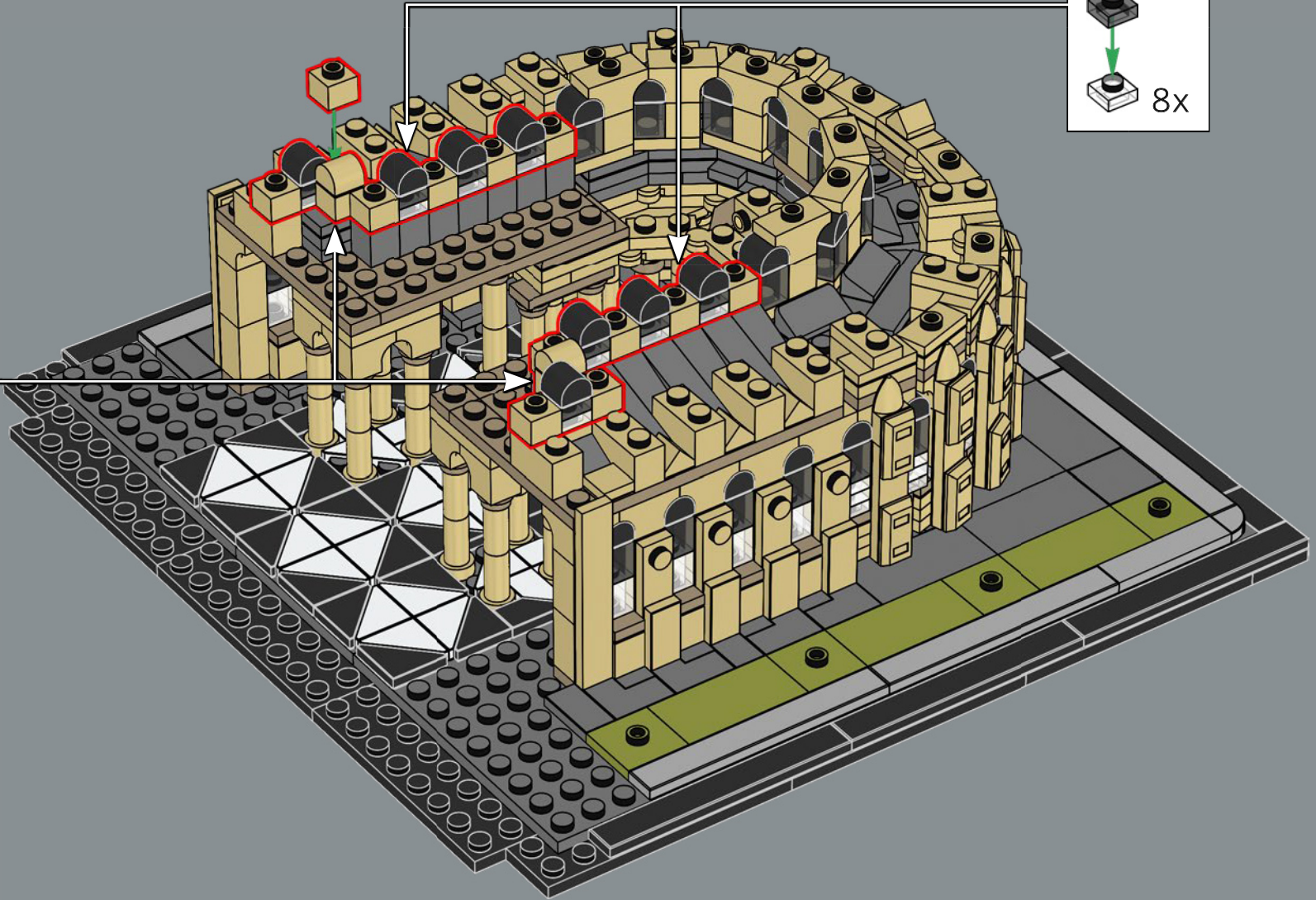
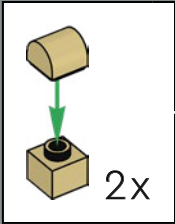
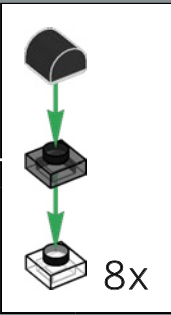

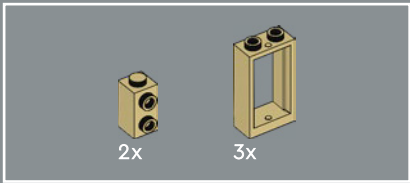

88

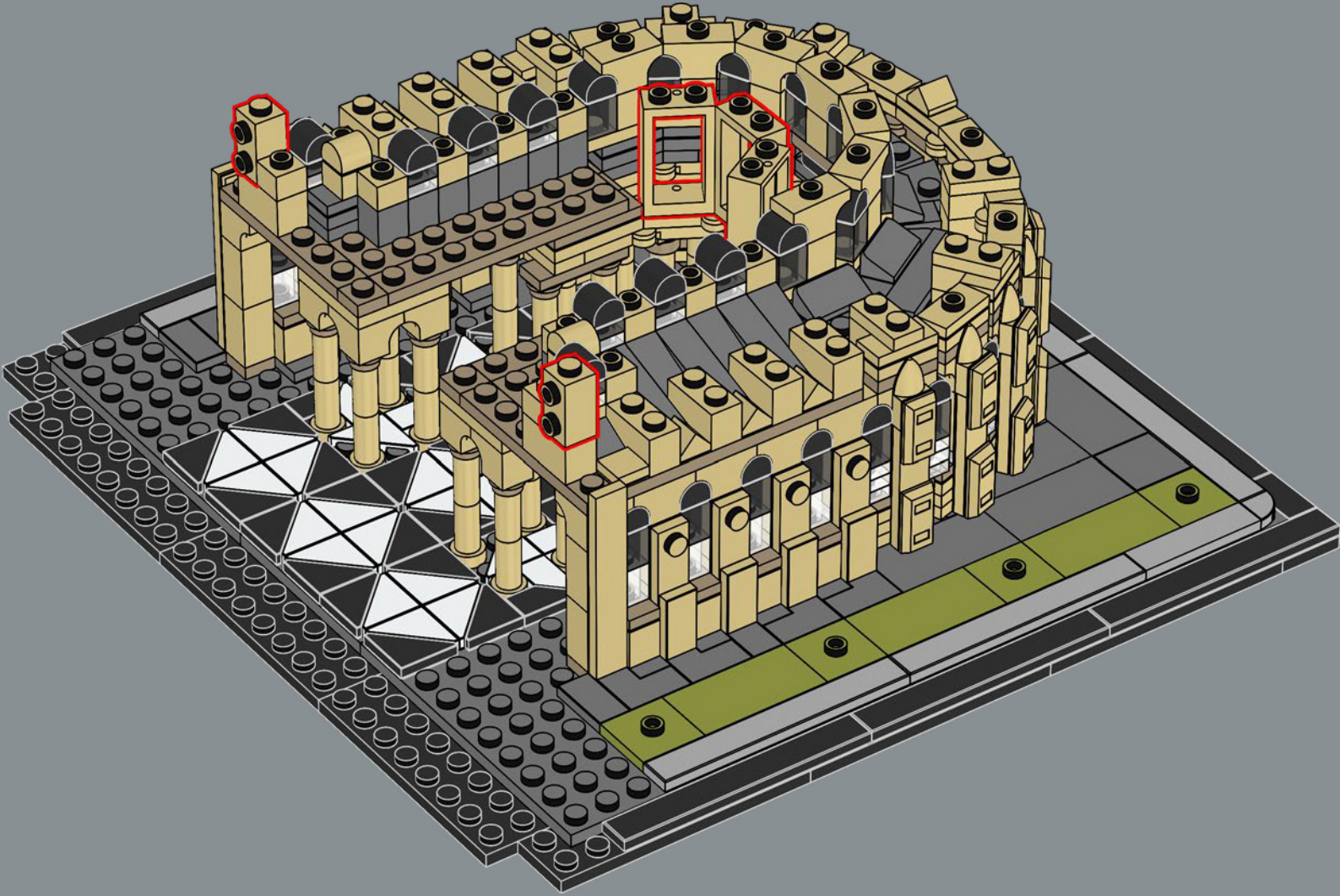

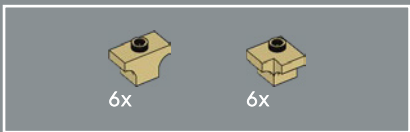

89

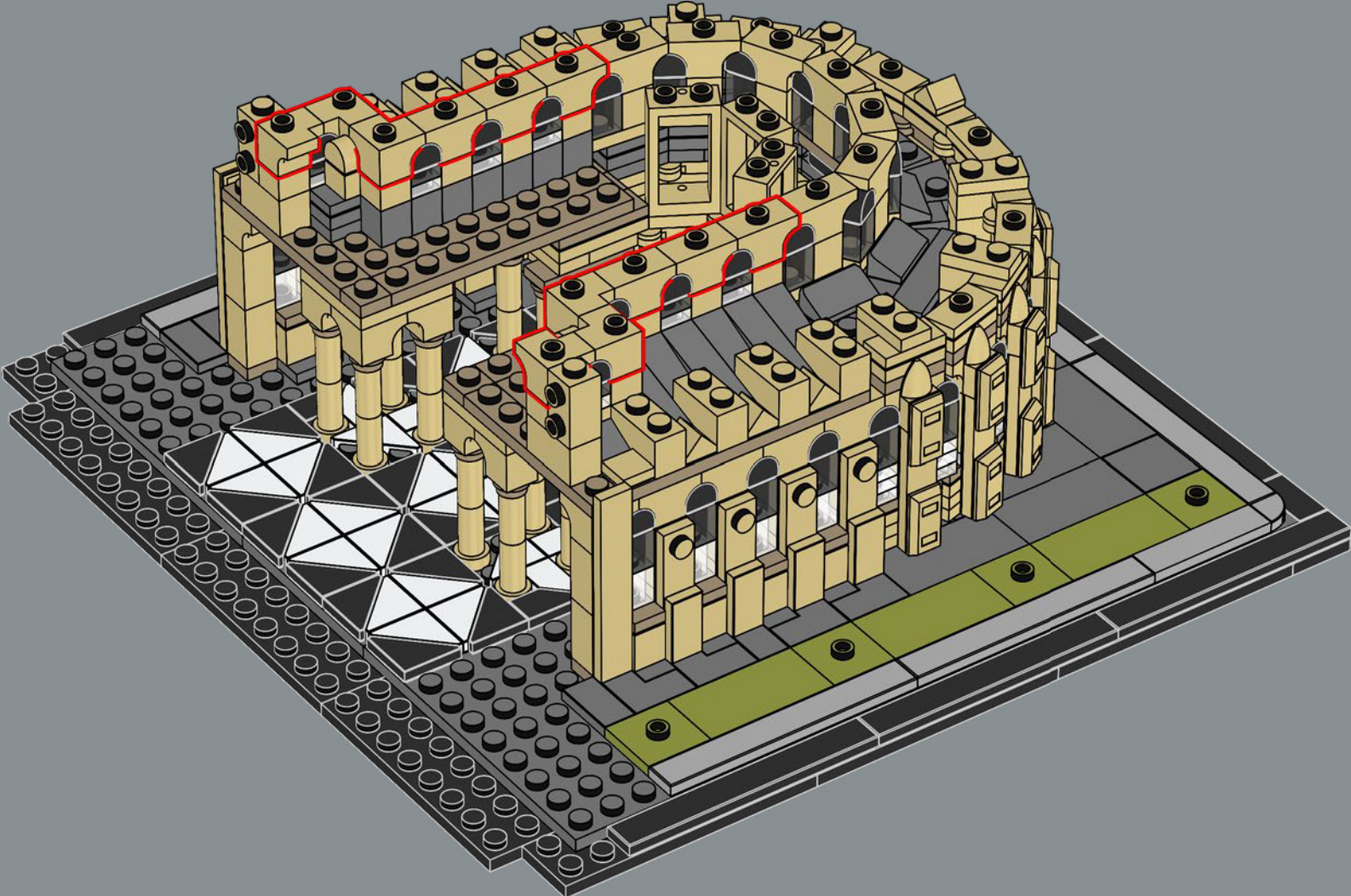

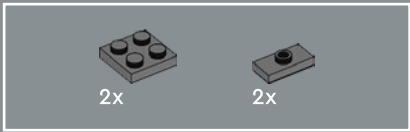

90

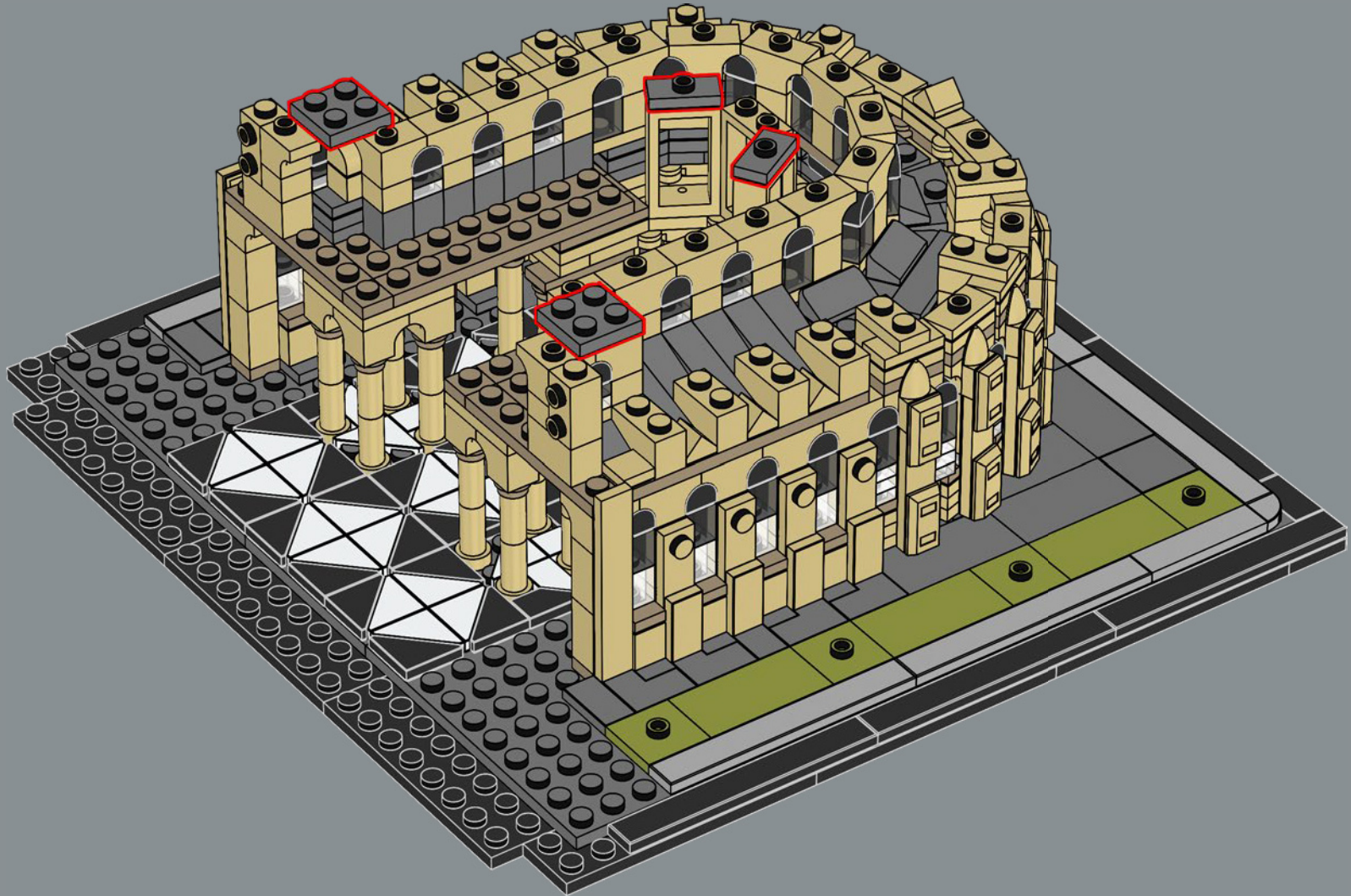



91

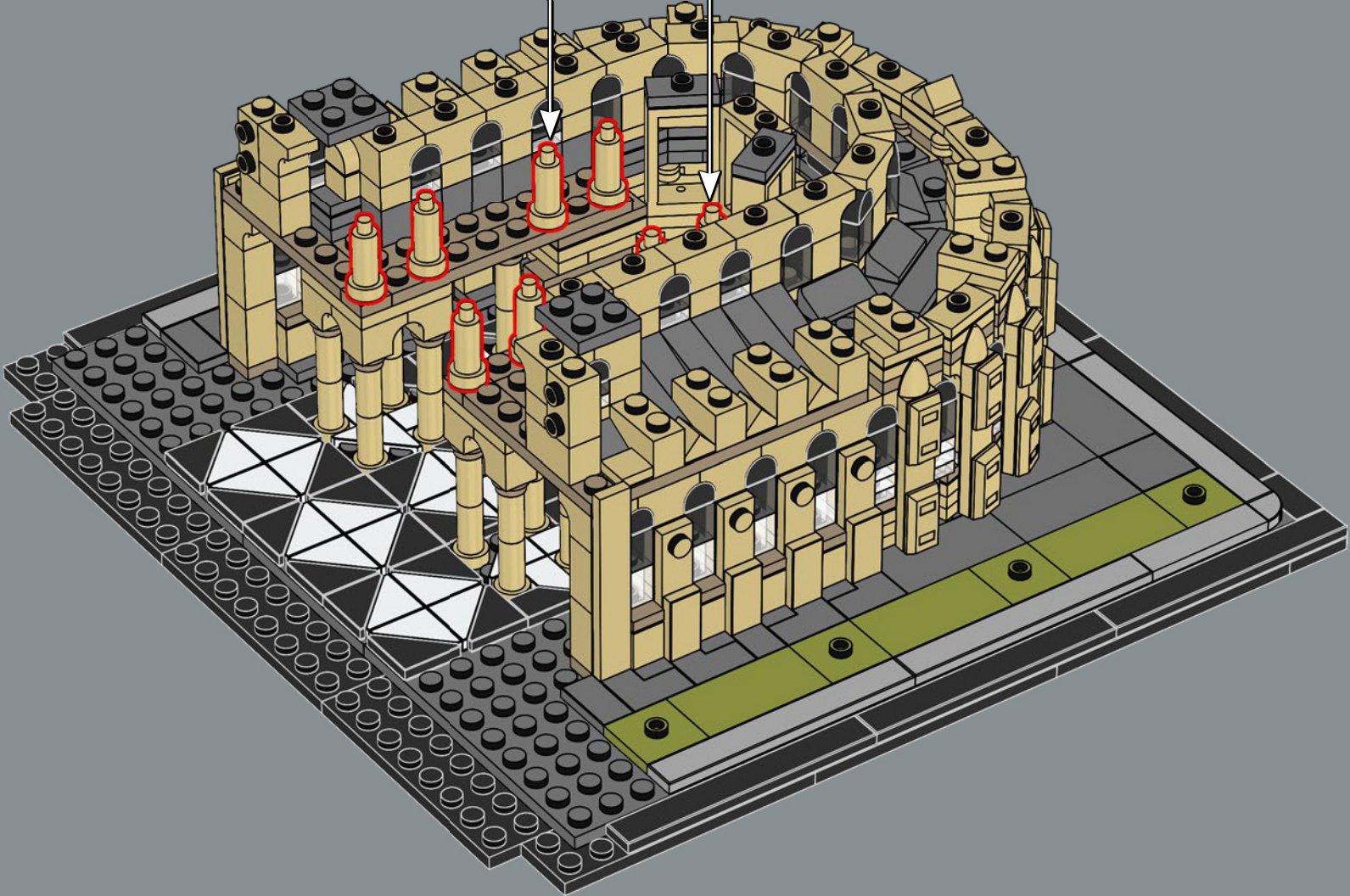
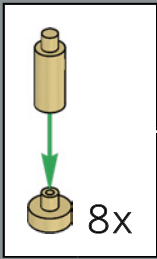

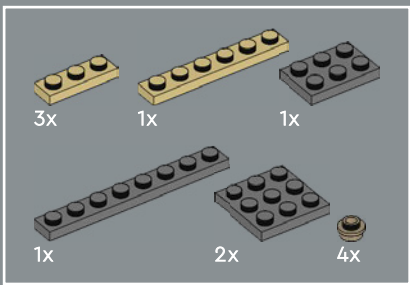

92

1

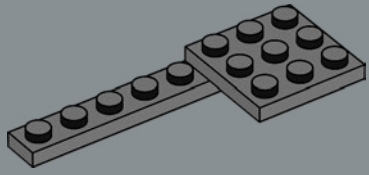

2

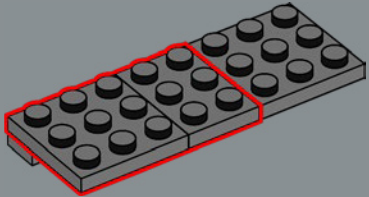

3

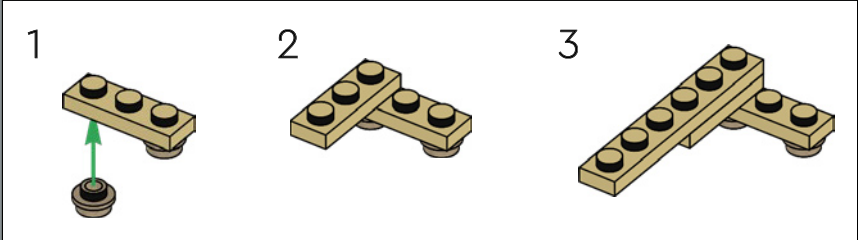
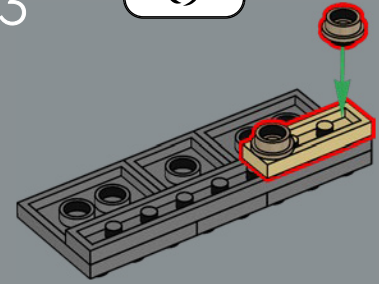

4

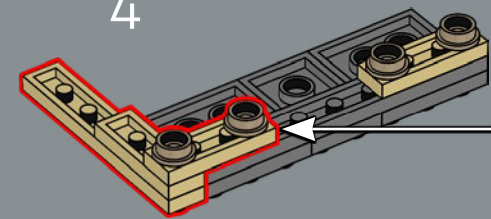

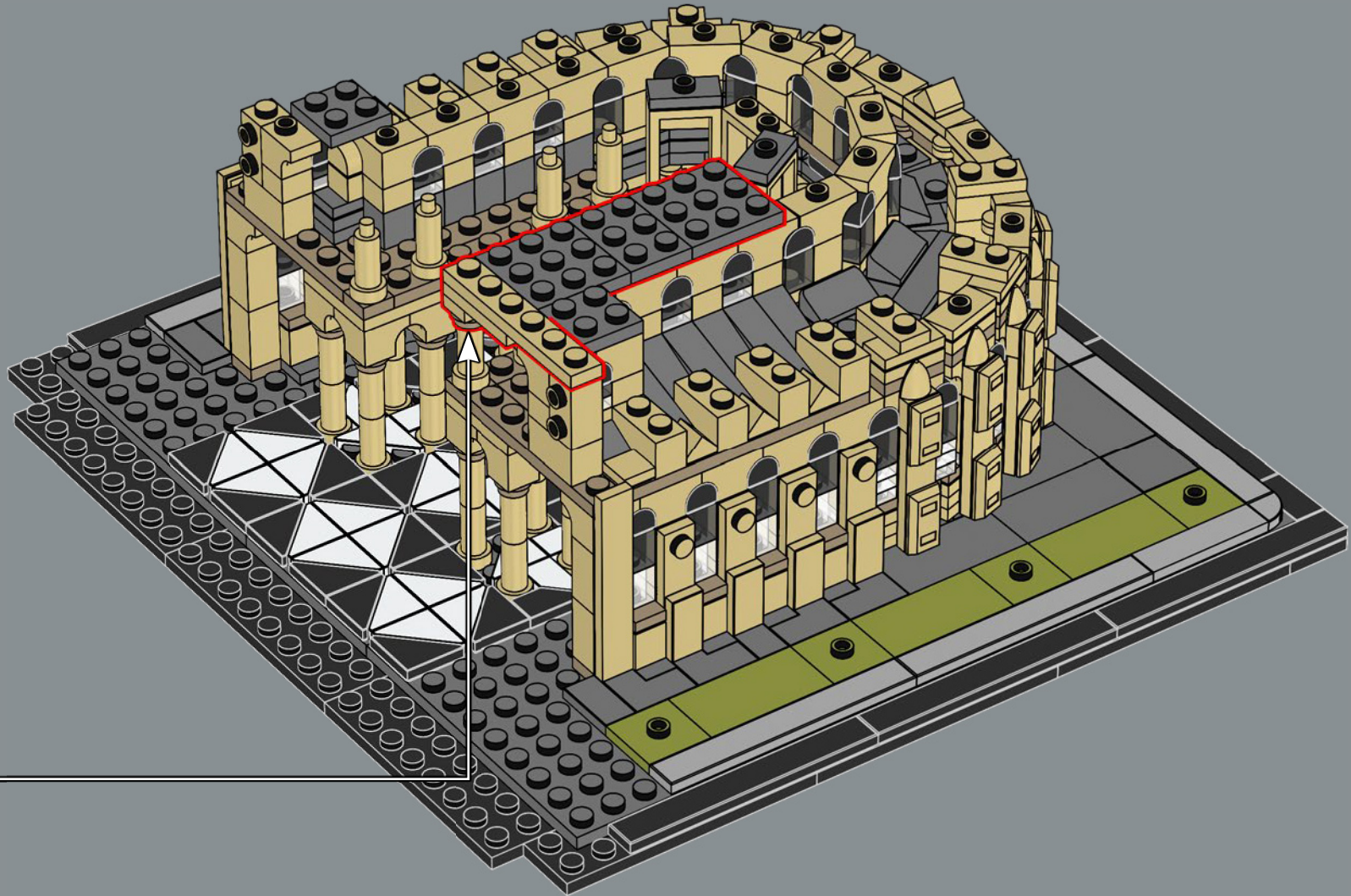

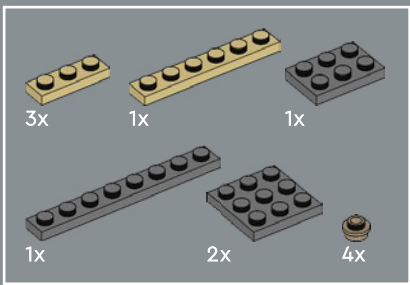

93

1

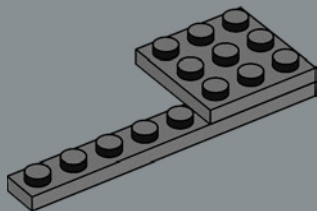

2

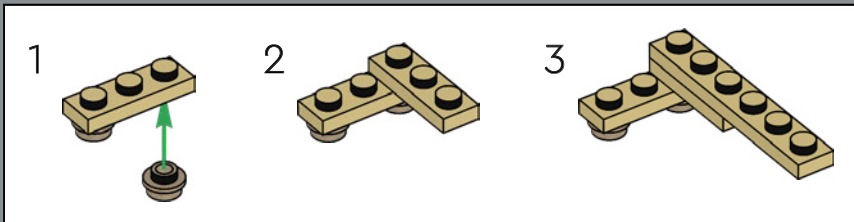
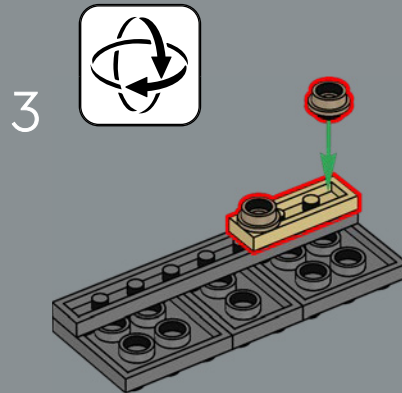
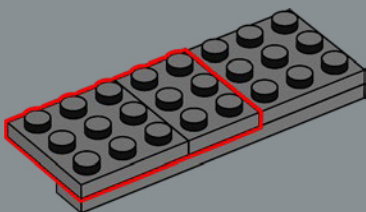

4

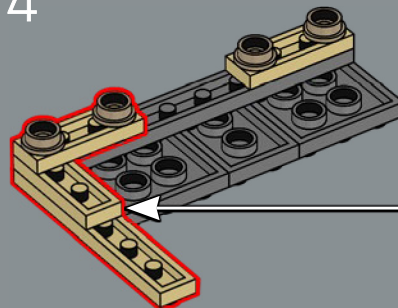

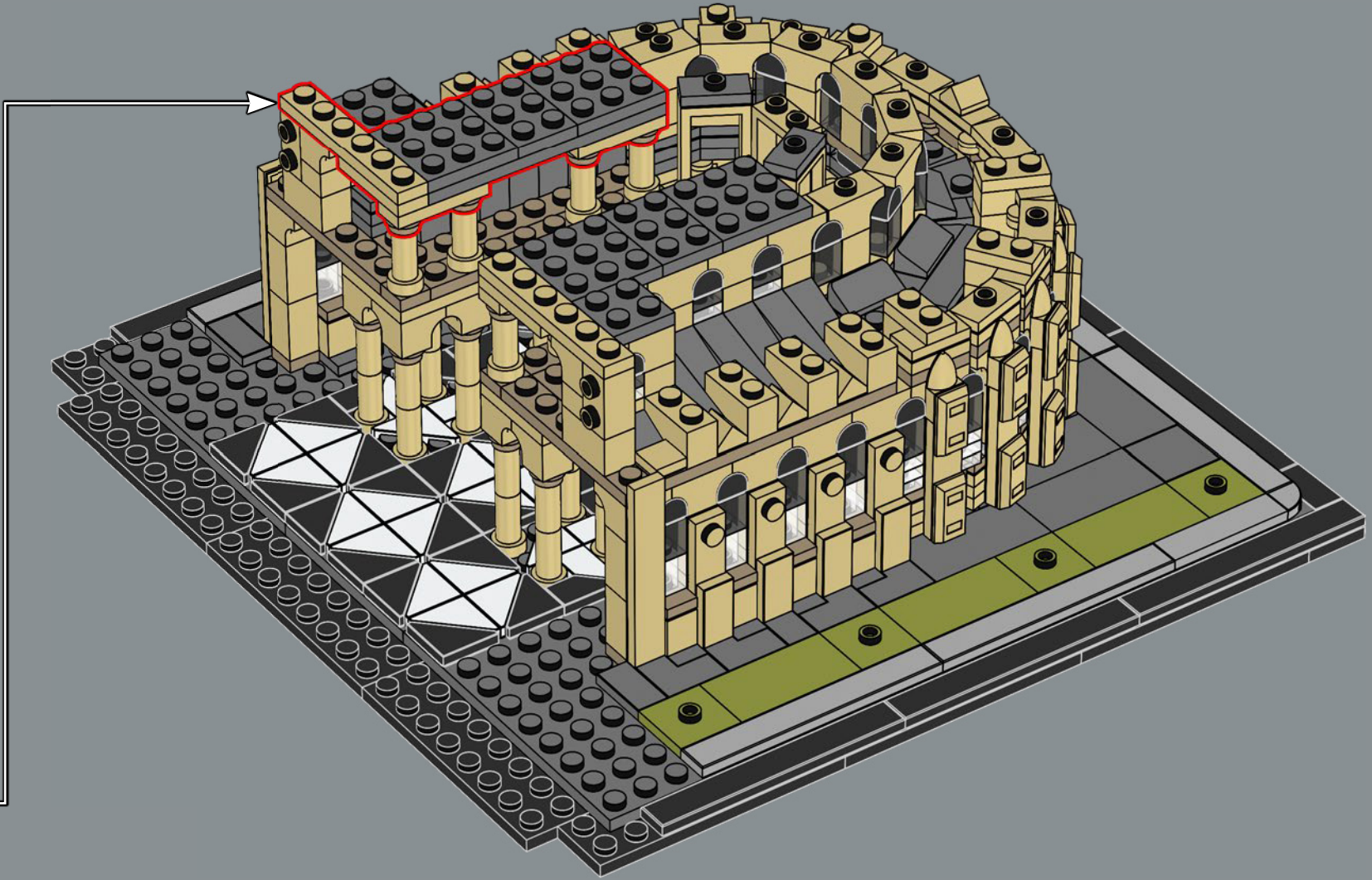



6x

94

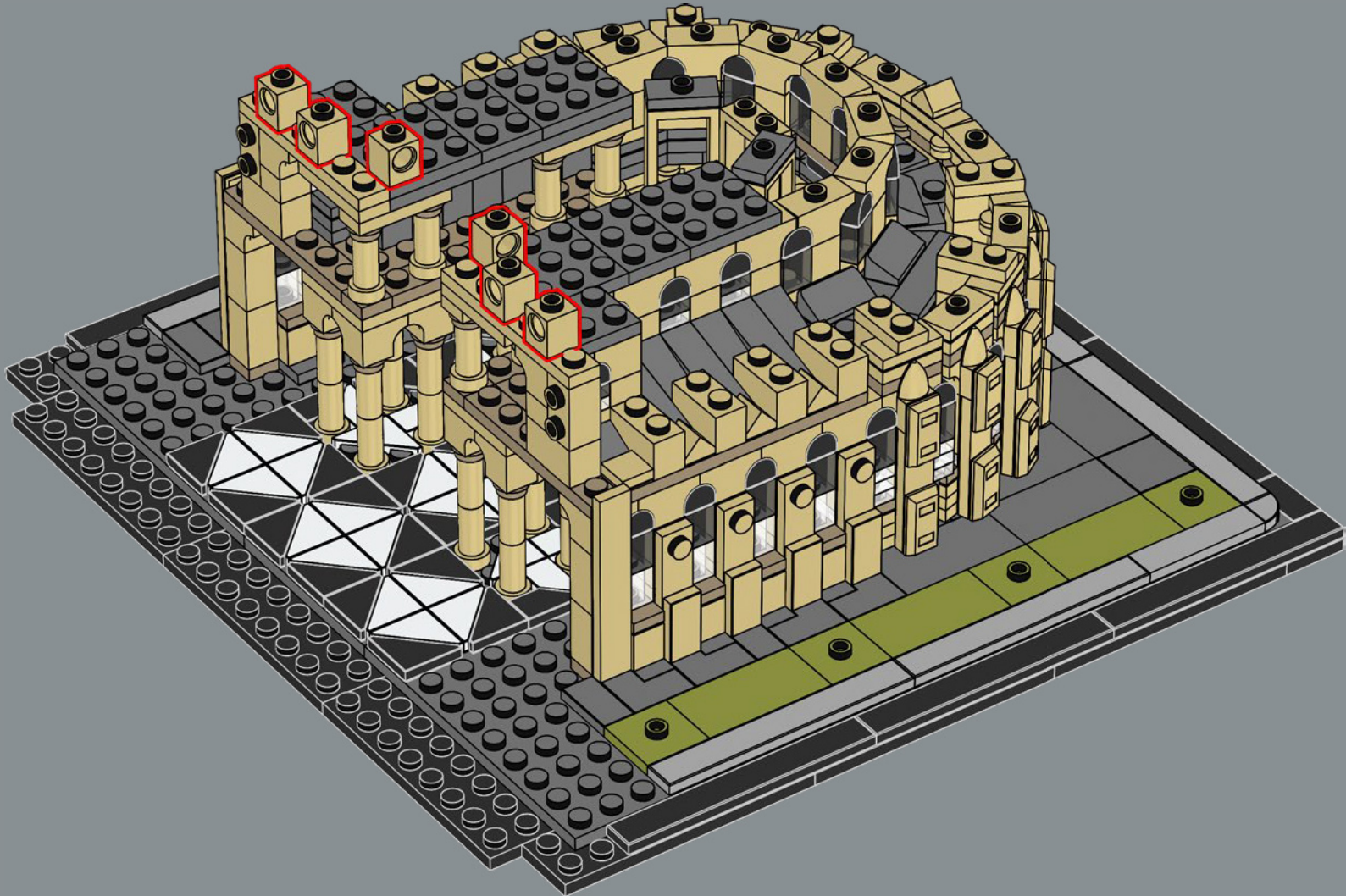

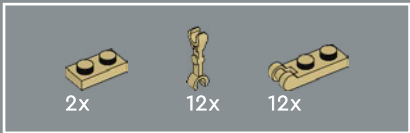

95

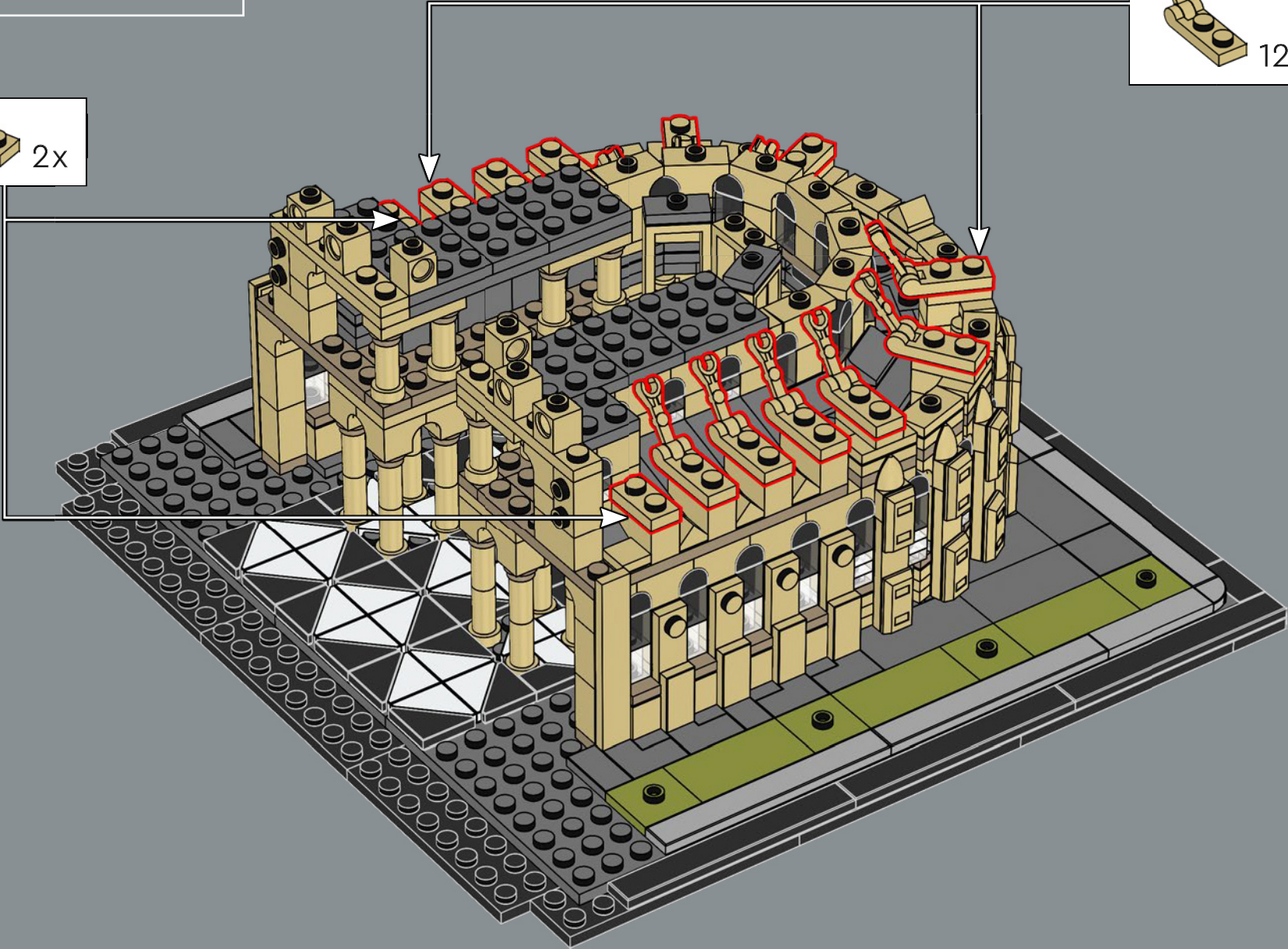
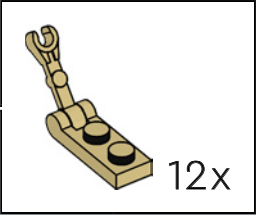

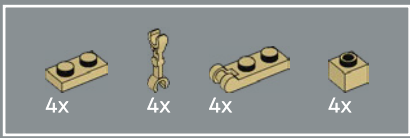

96

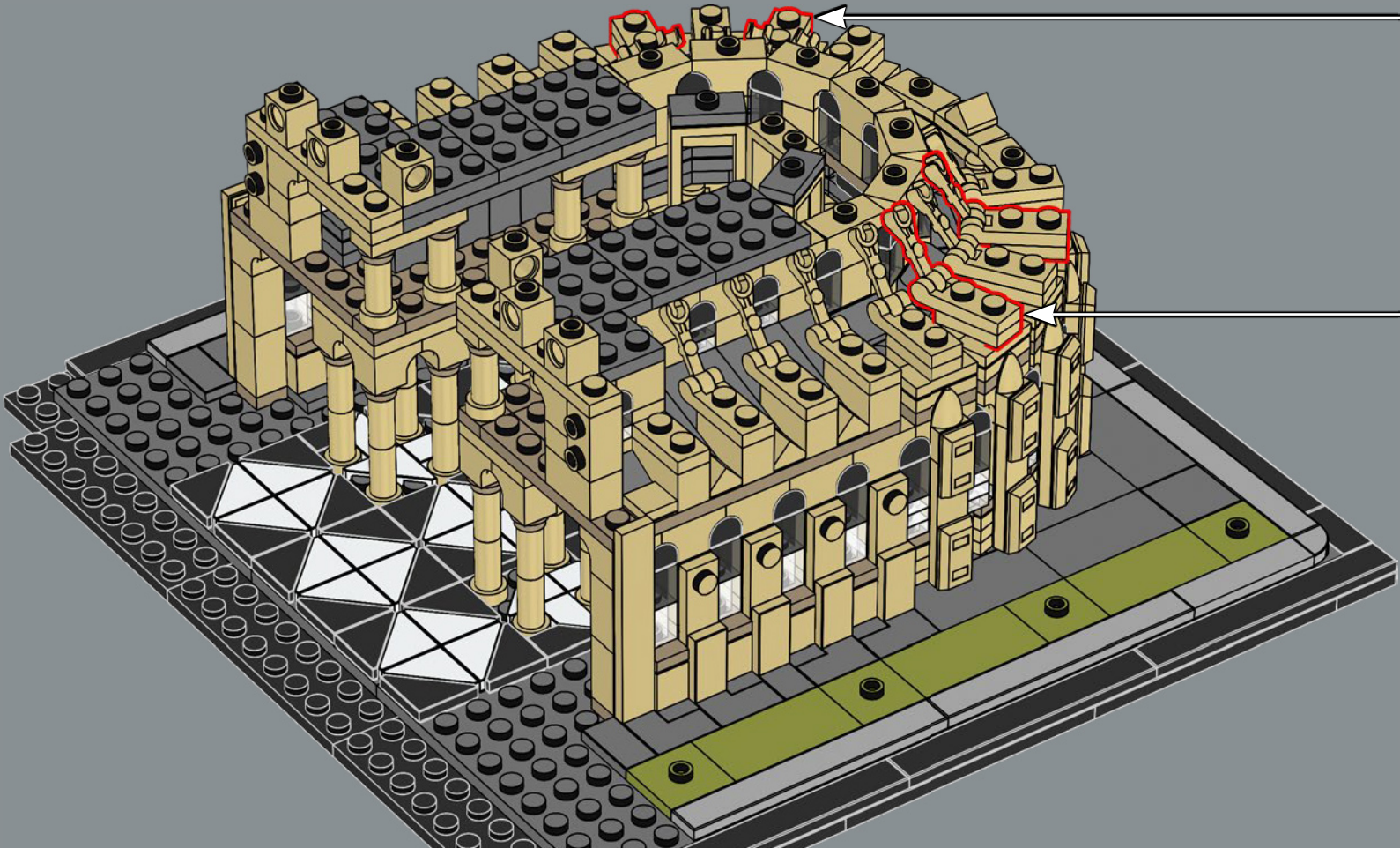
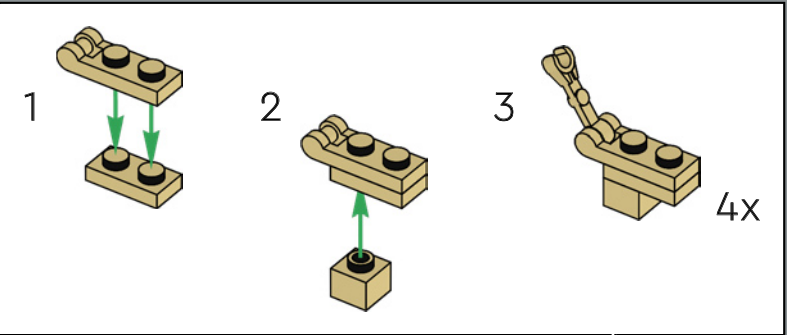

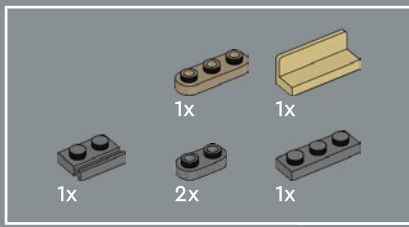

97

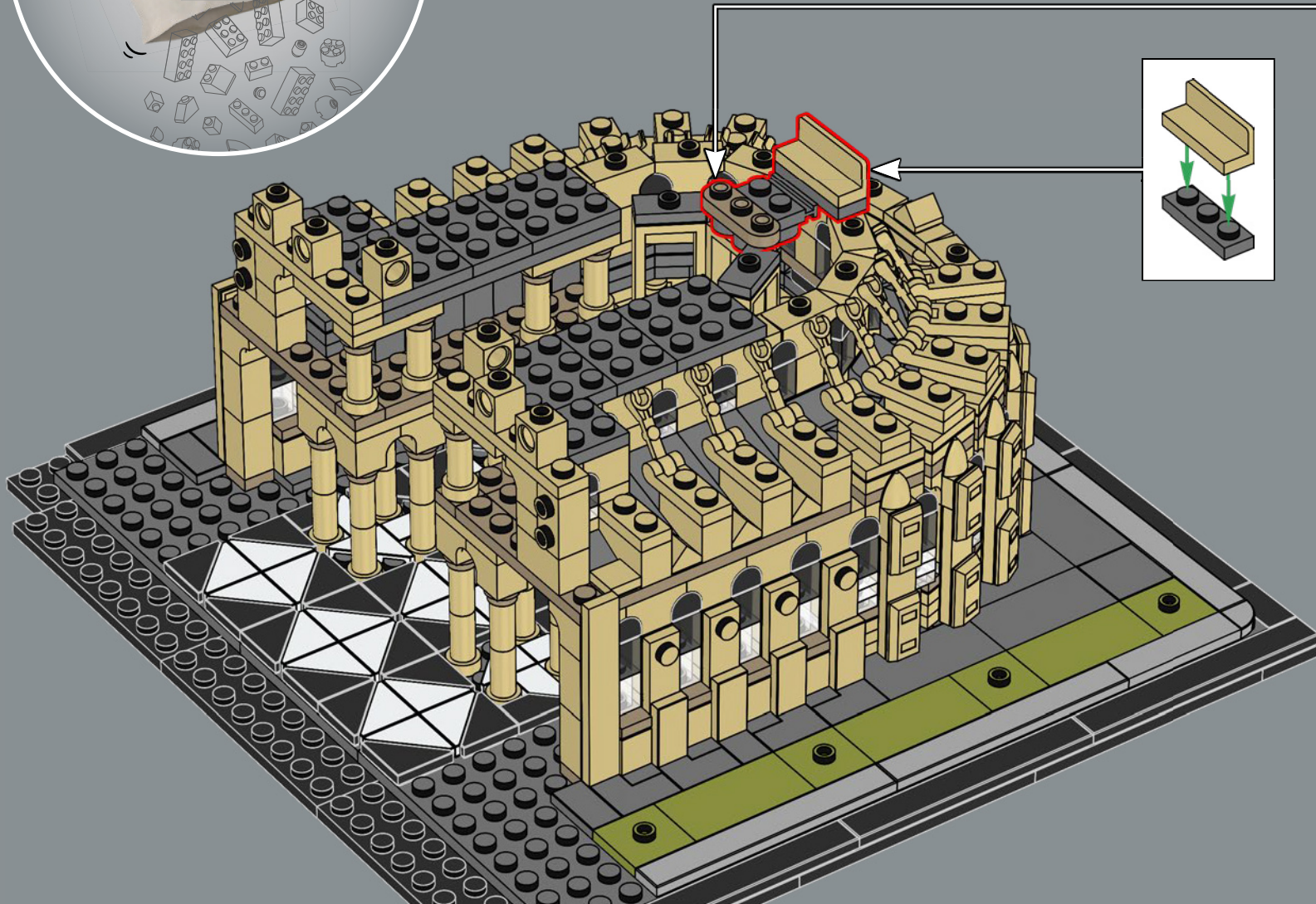
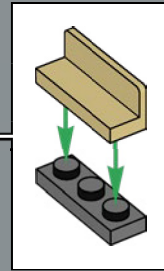
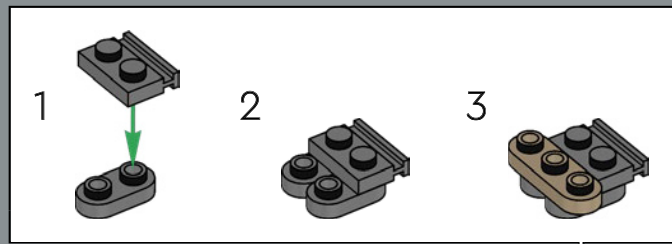



98

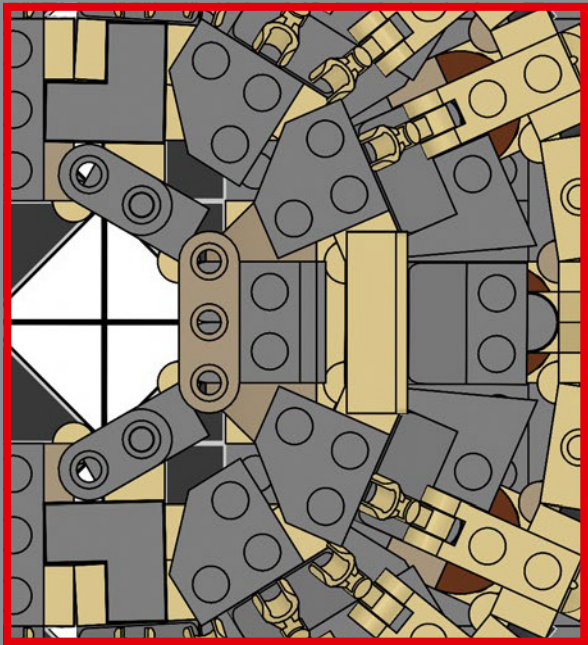
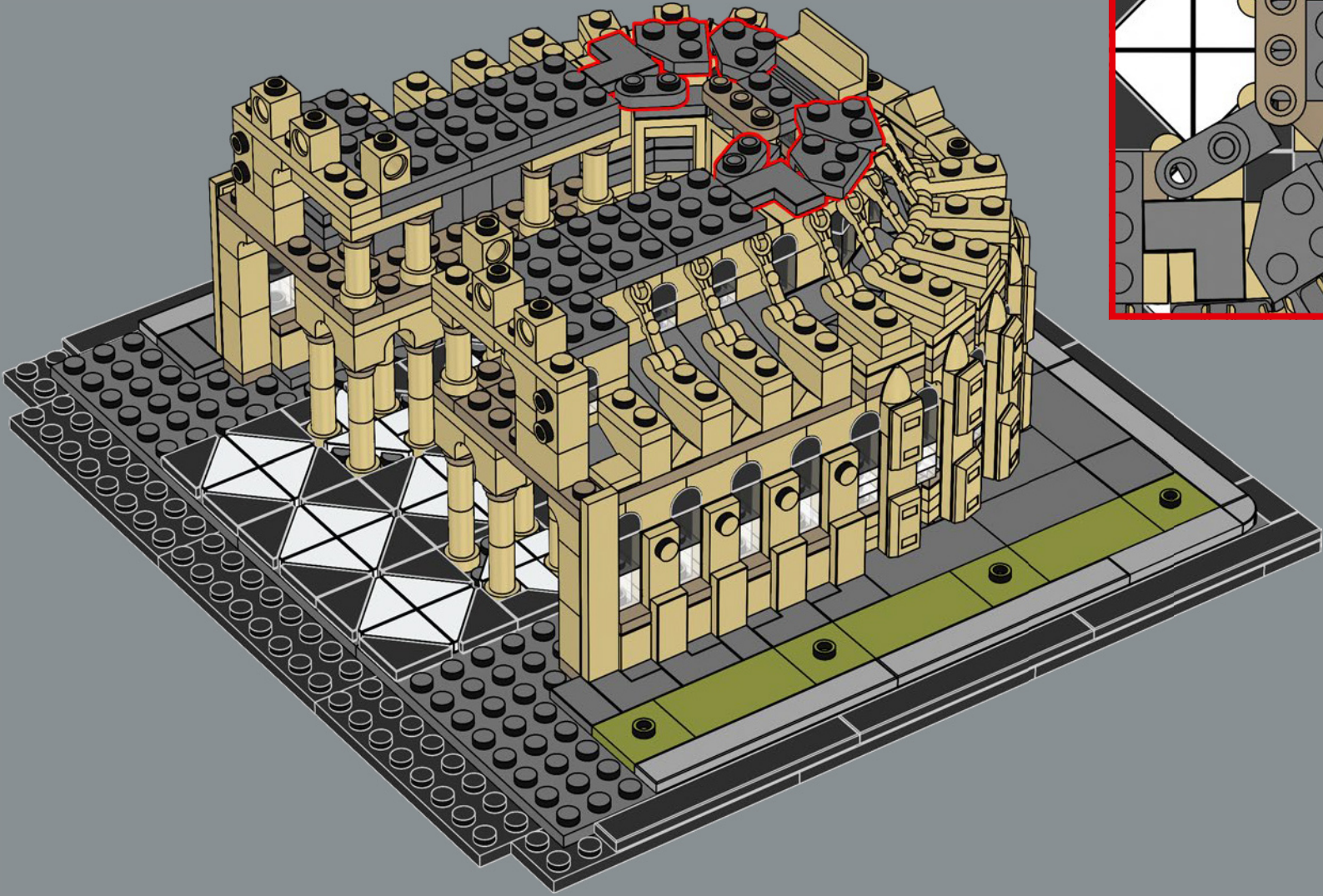



99

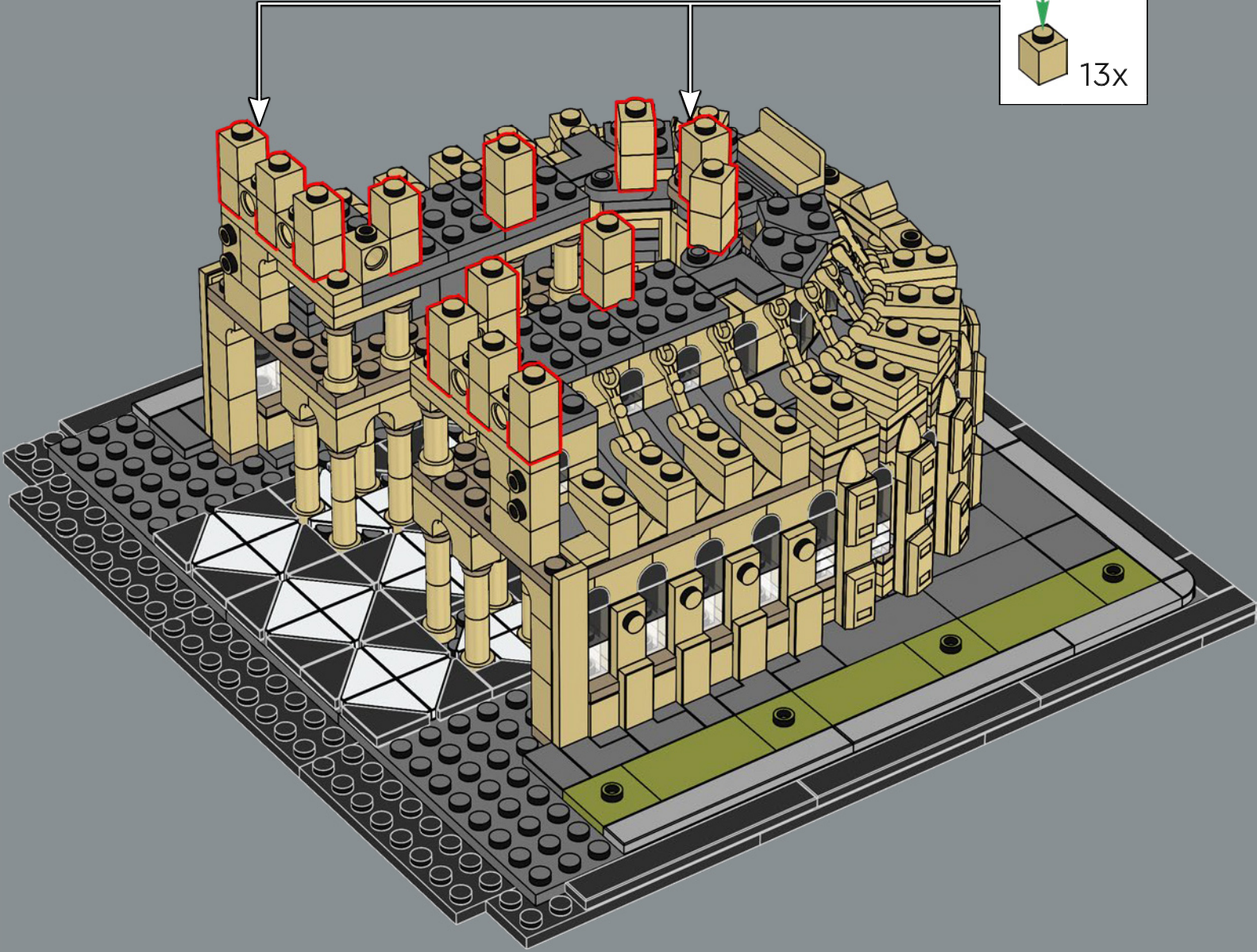
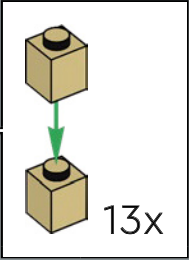

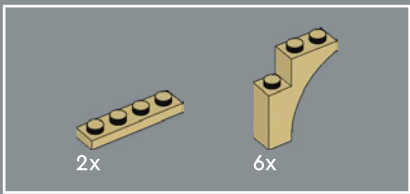

100

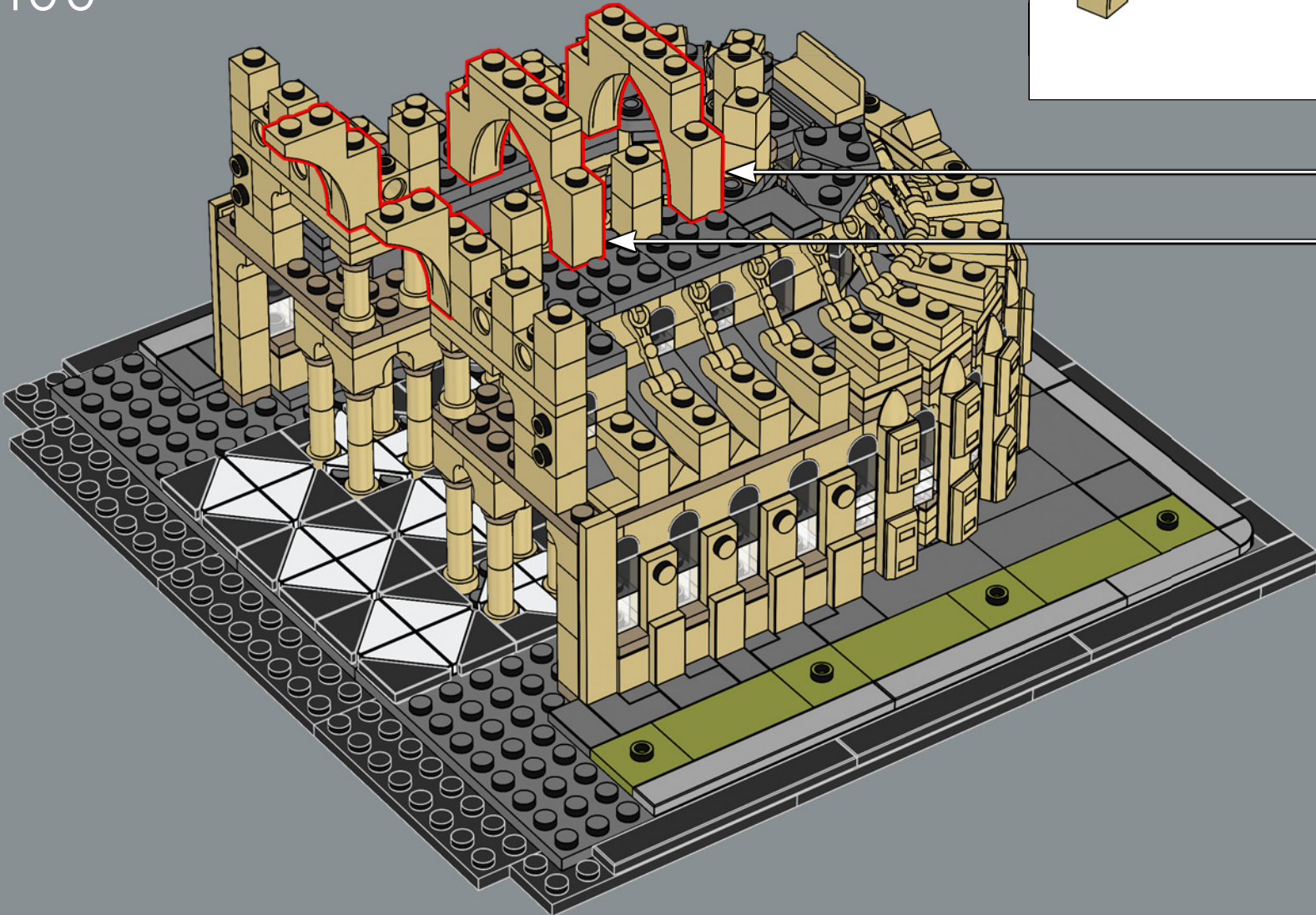
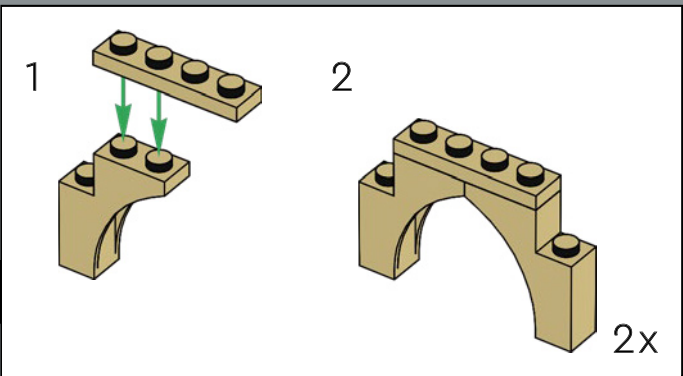

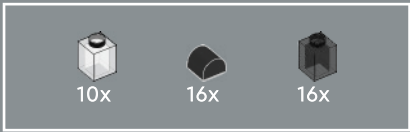

101

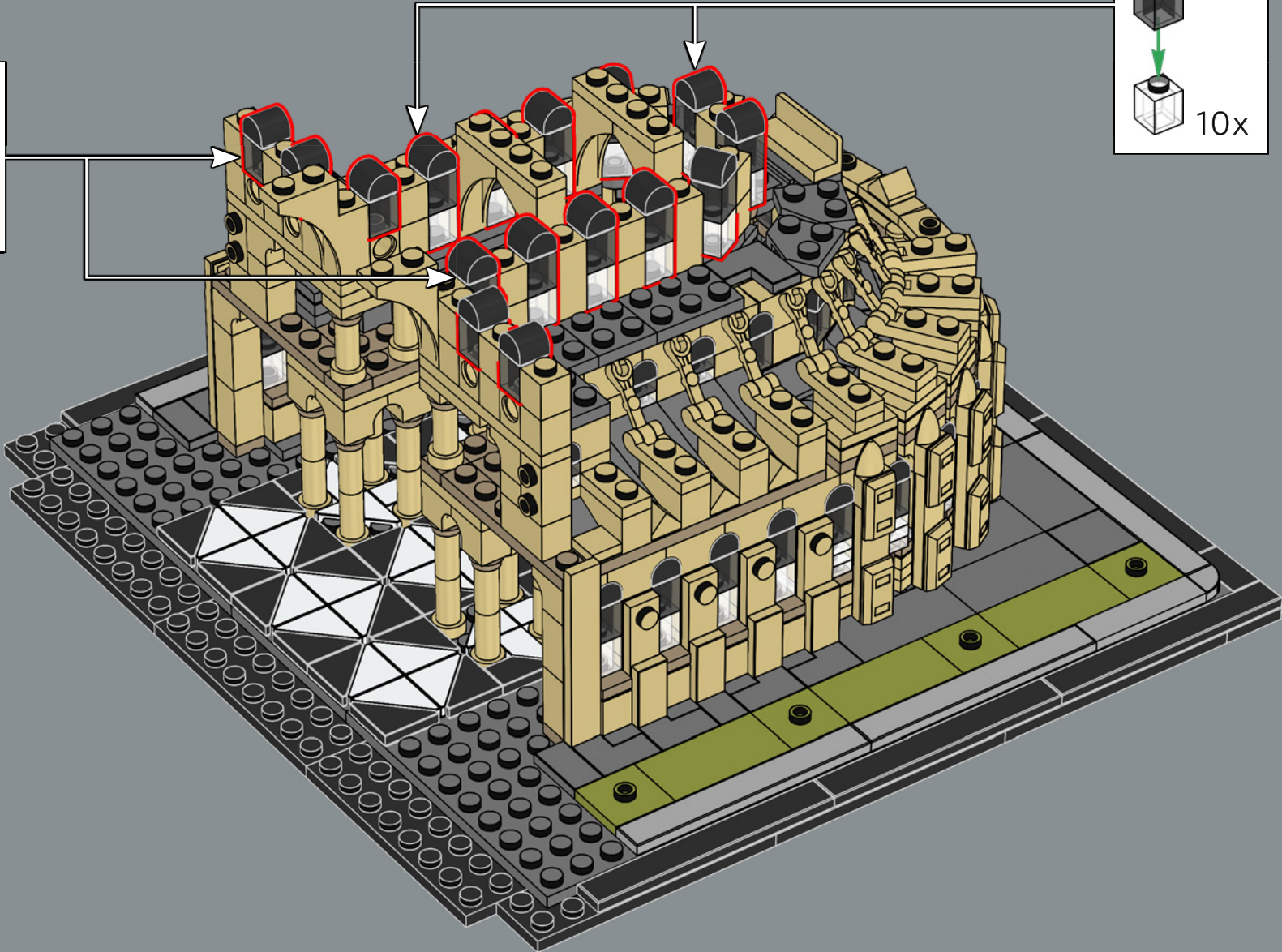
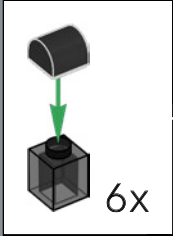

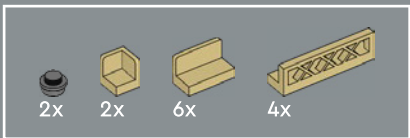

102

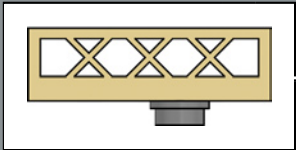
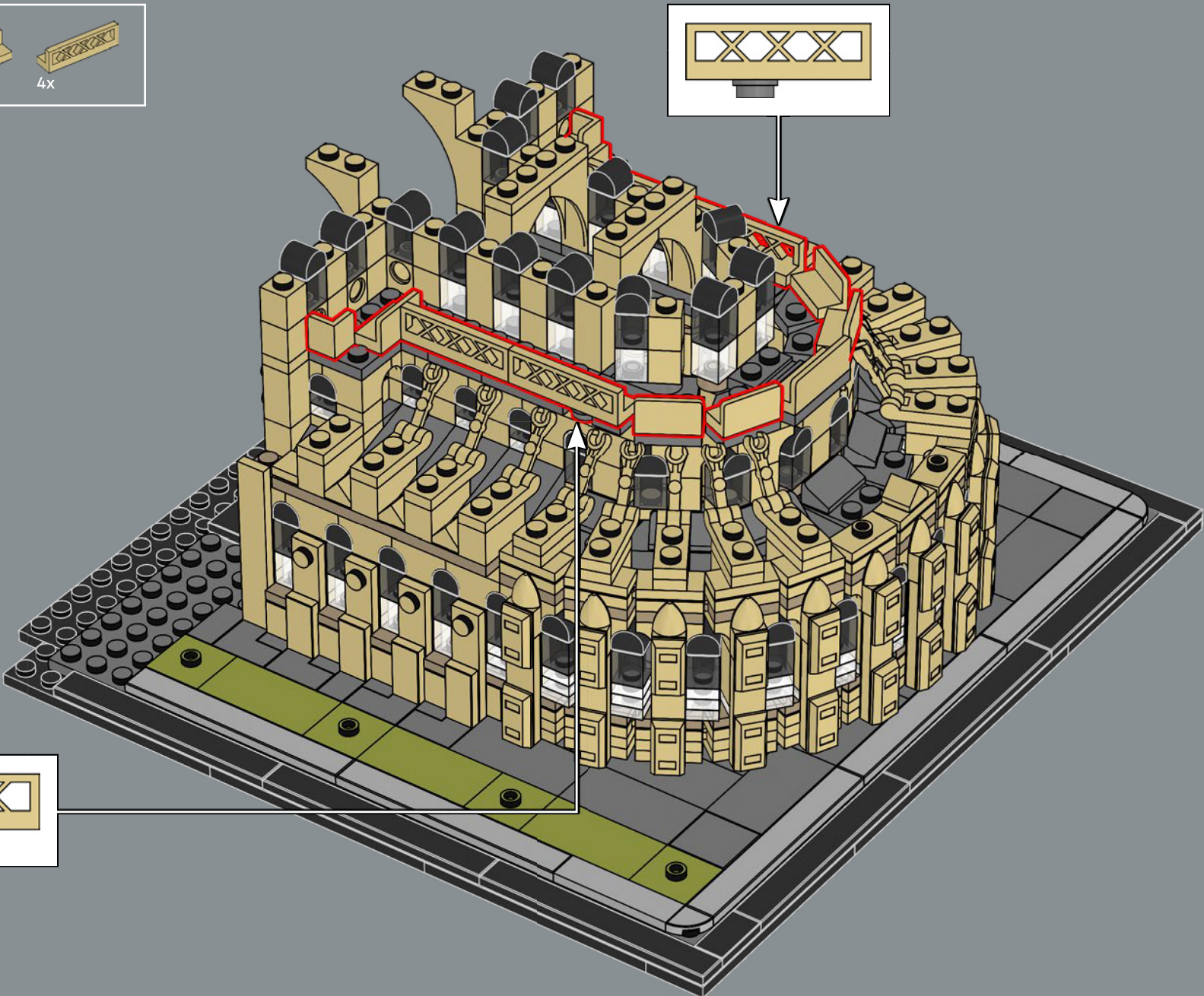

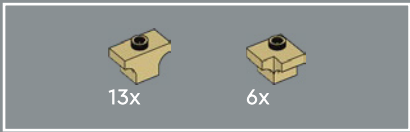

103

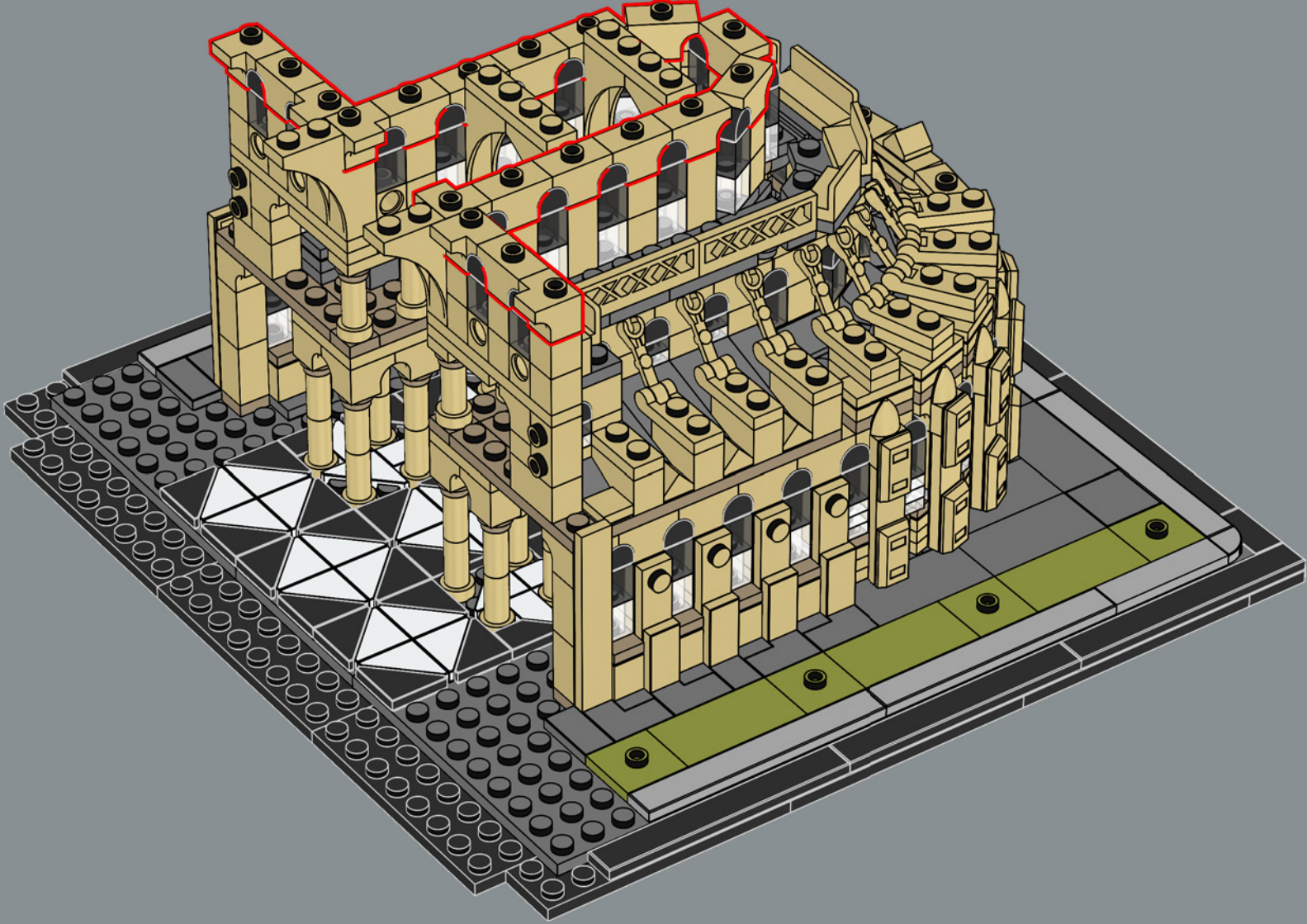

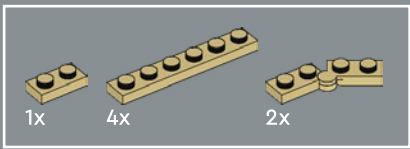

104

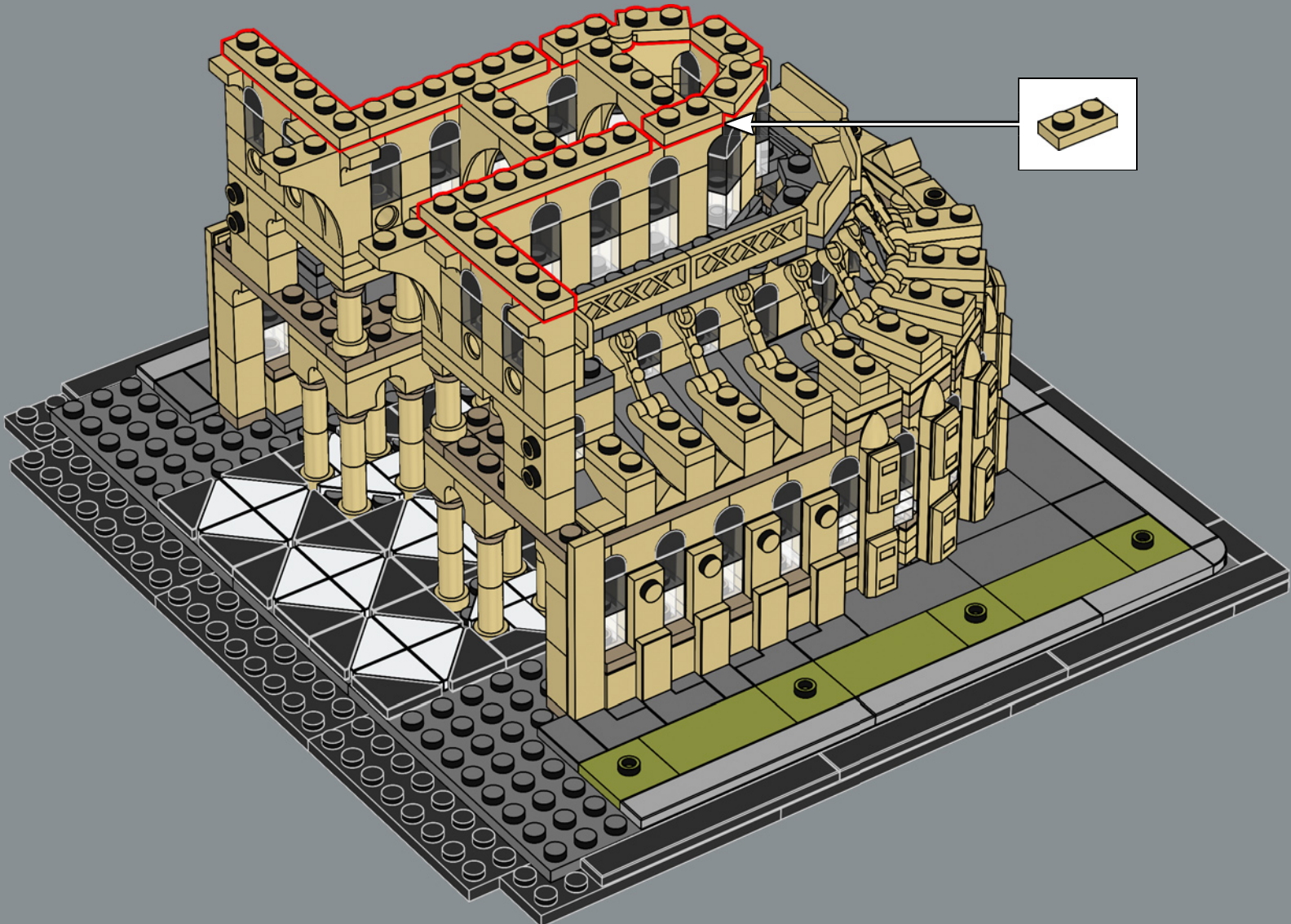

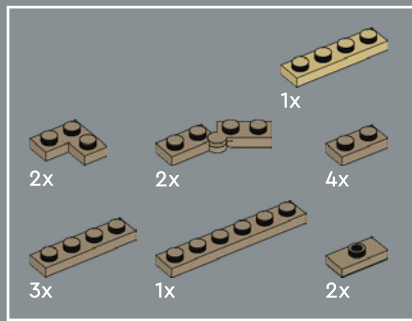

105

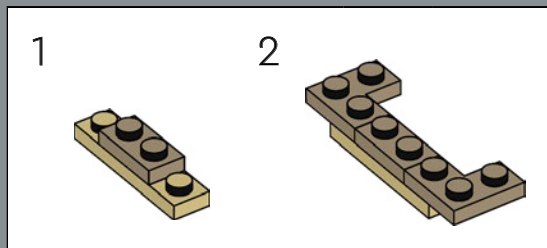
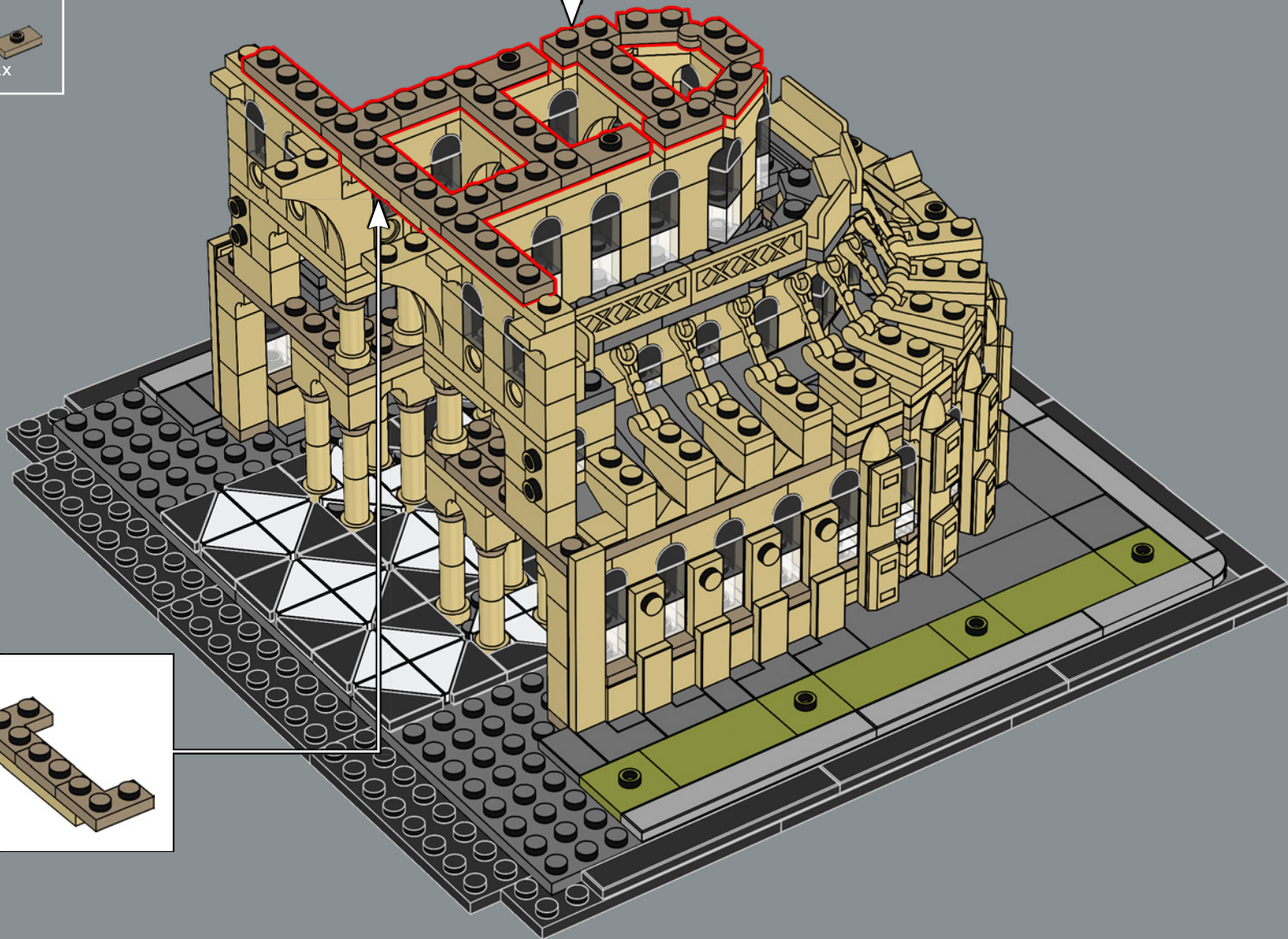
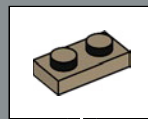

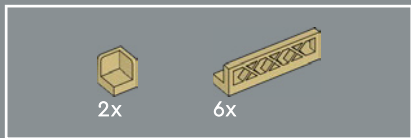

106

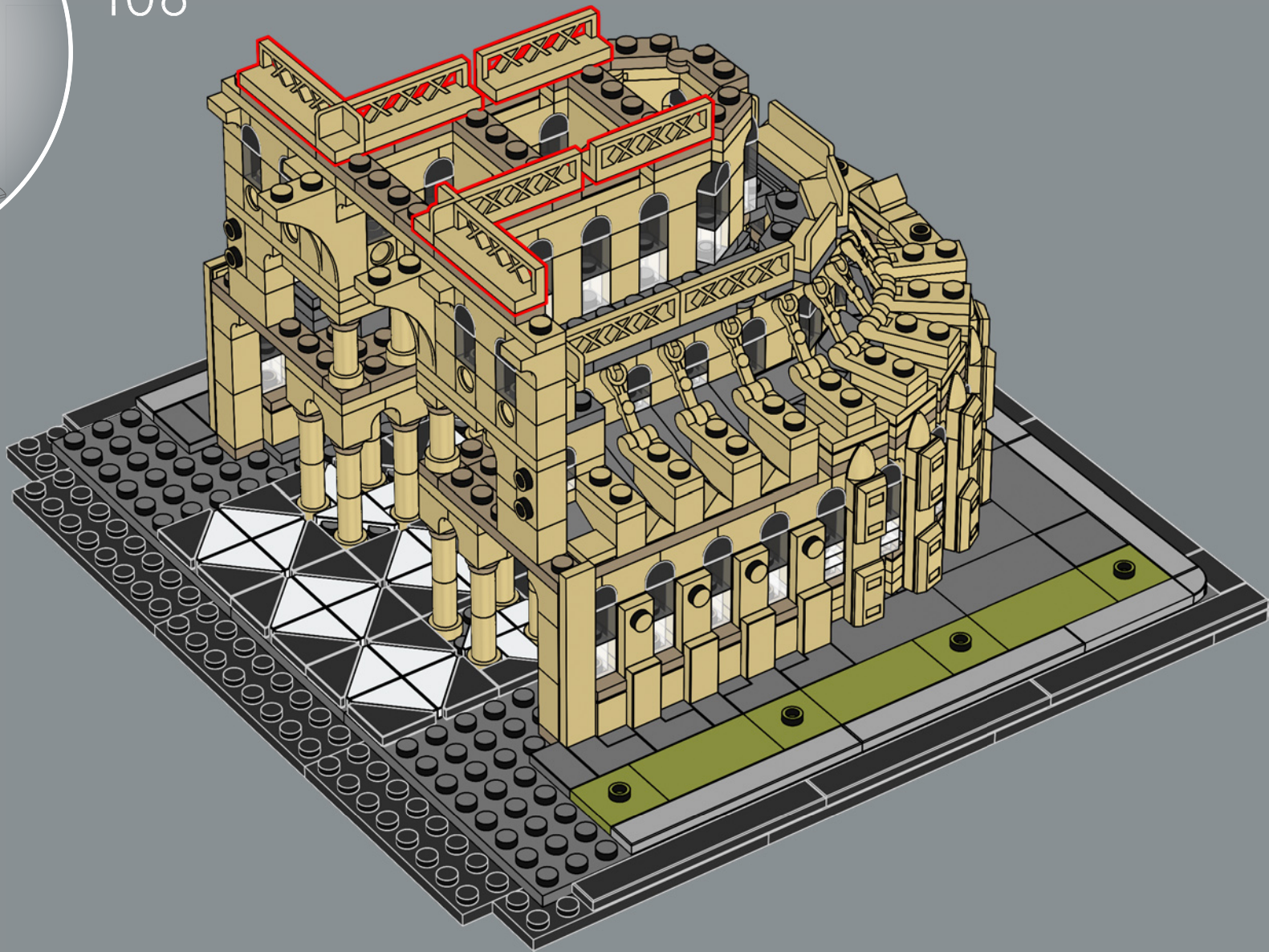

6x 10x

4x

6x

107

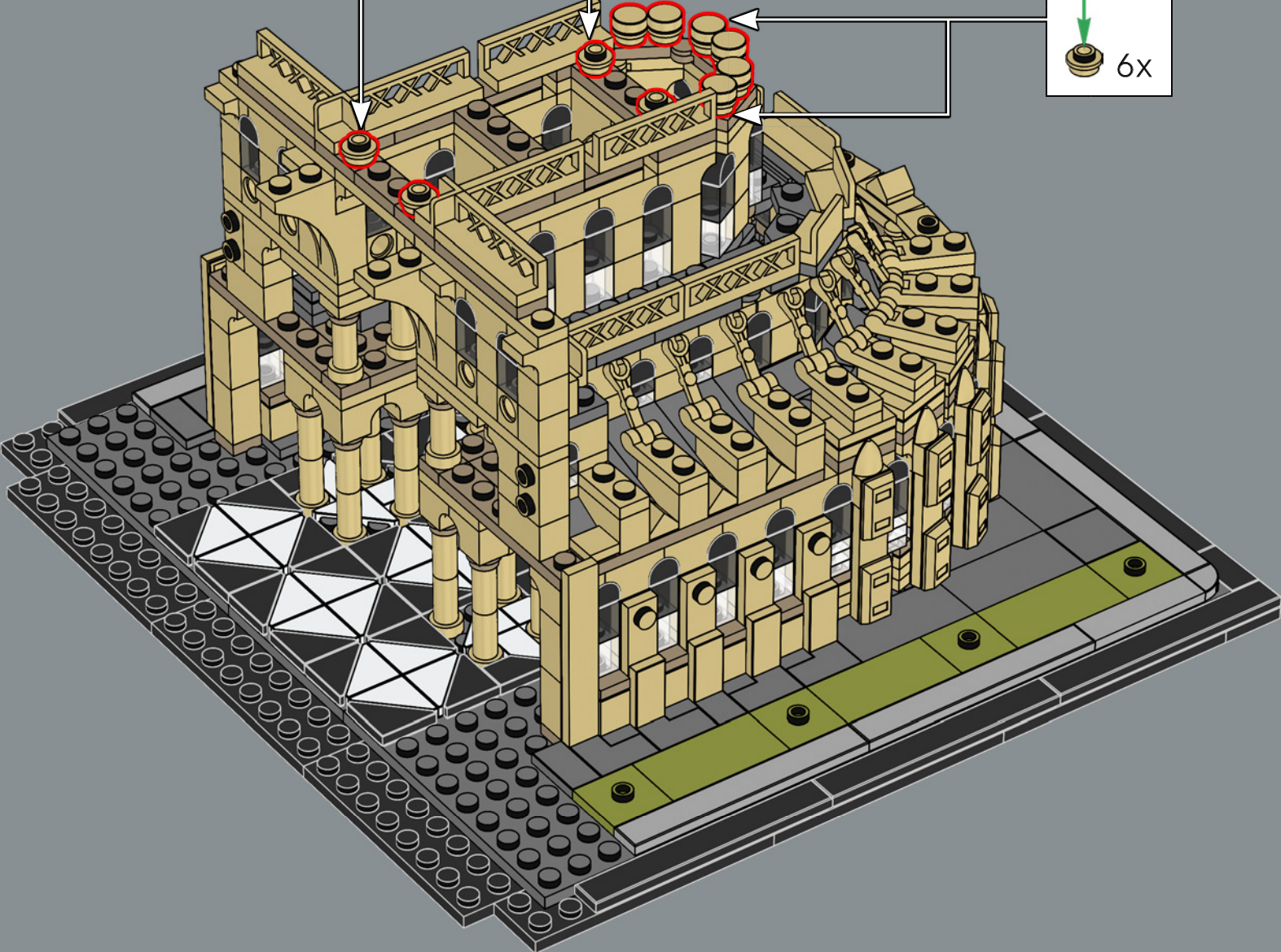

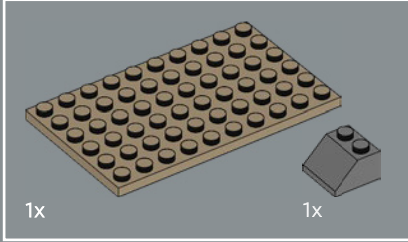
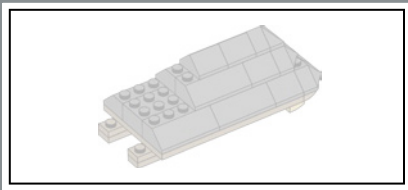

108

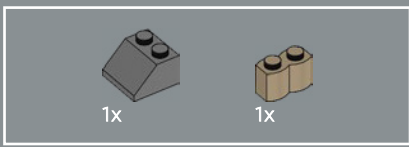
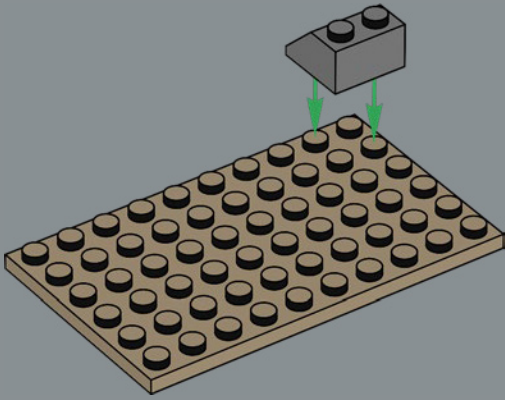

109

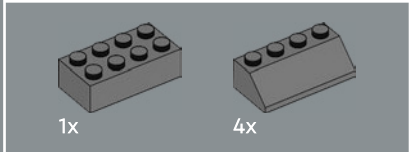
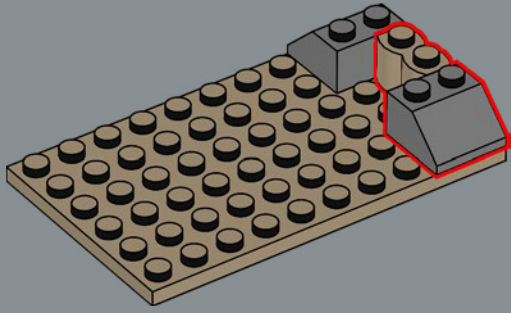

110

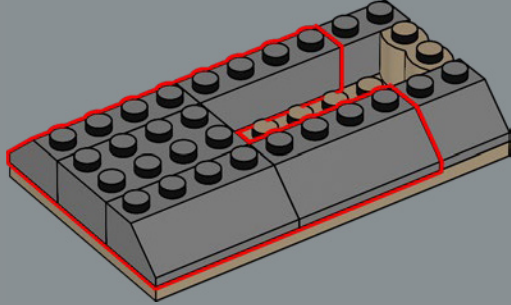

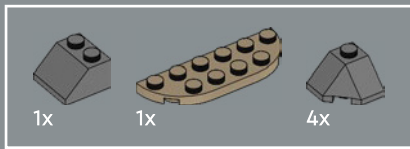

111

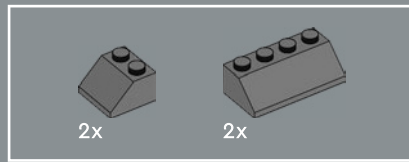
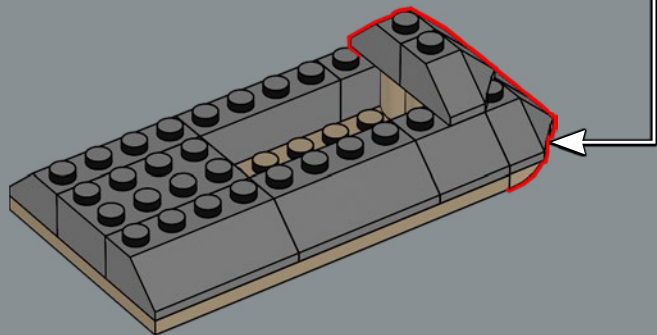

112

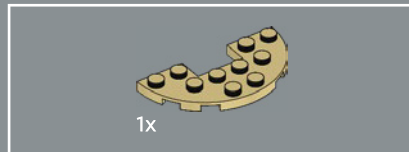
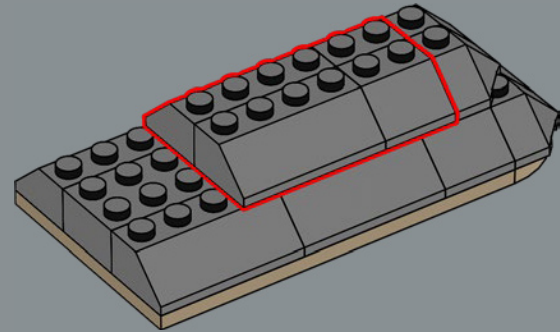

113

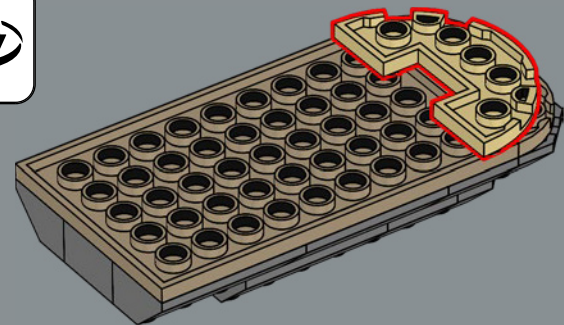

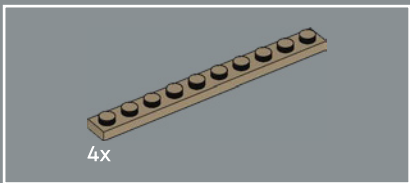

114

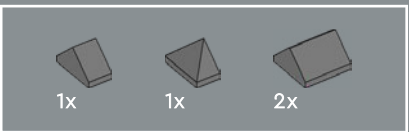
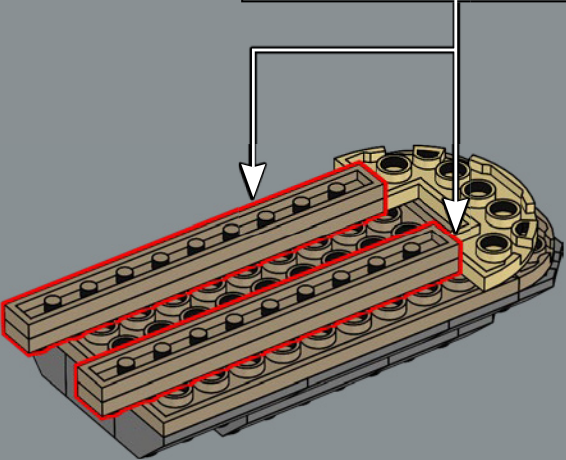
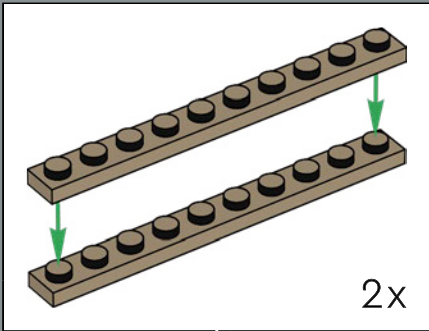

115

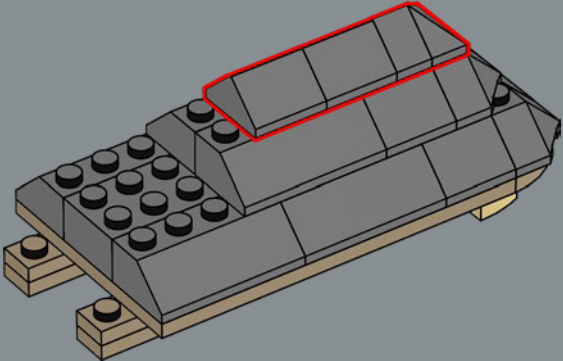

1177年——除了高处拱顶，唱诗堂和圆室几乎完工。
屋顶和木质框架是在拱顶之前建造的，以防止磨损。

116

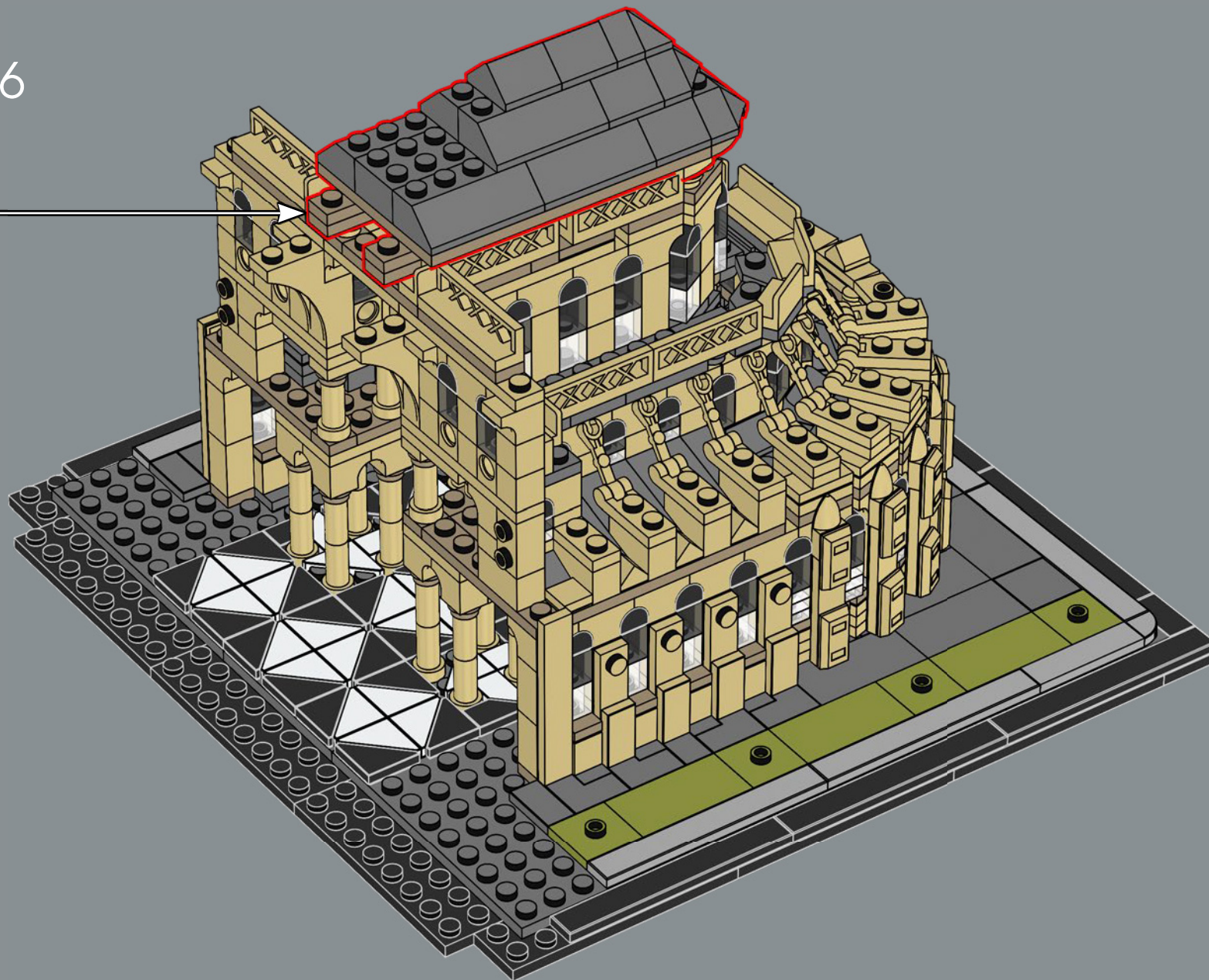

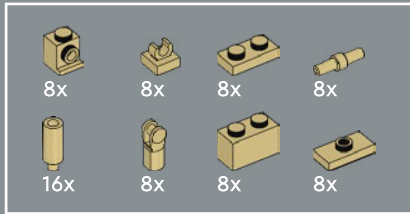
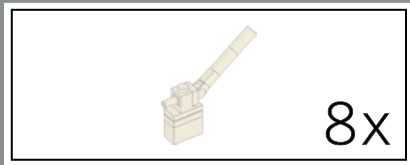

117

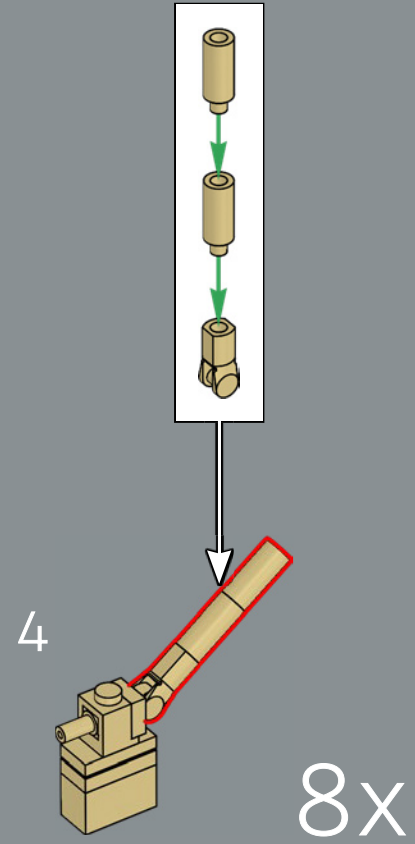
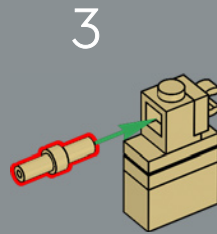
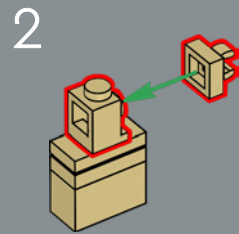
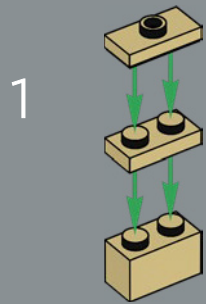

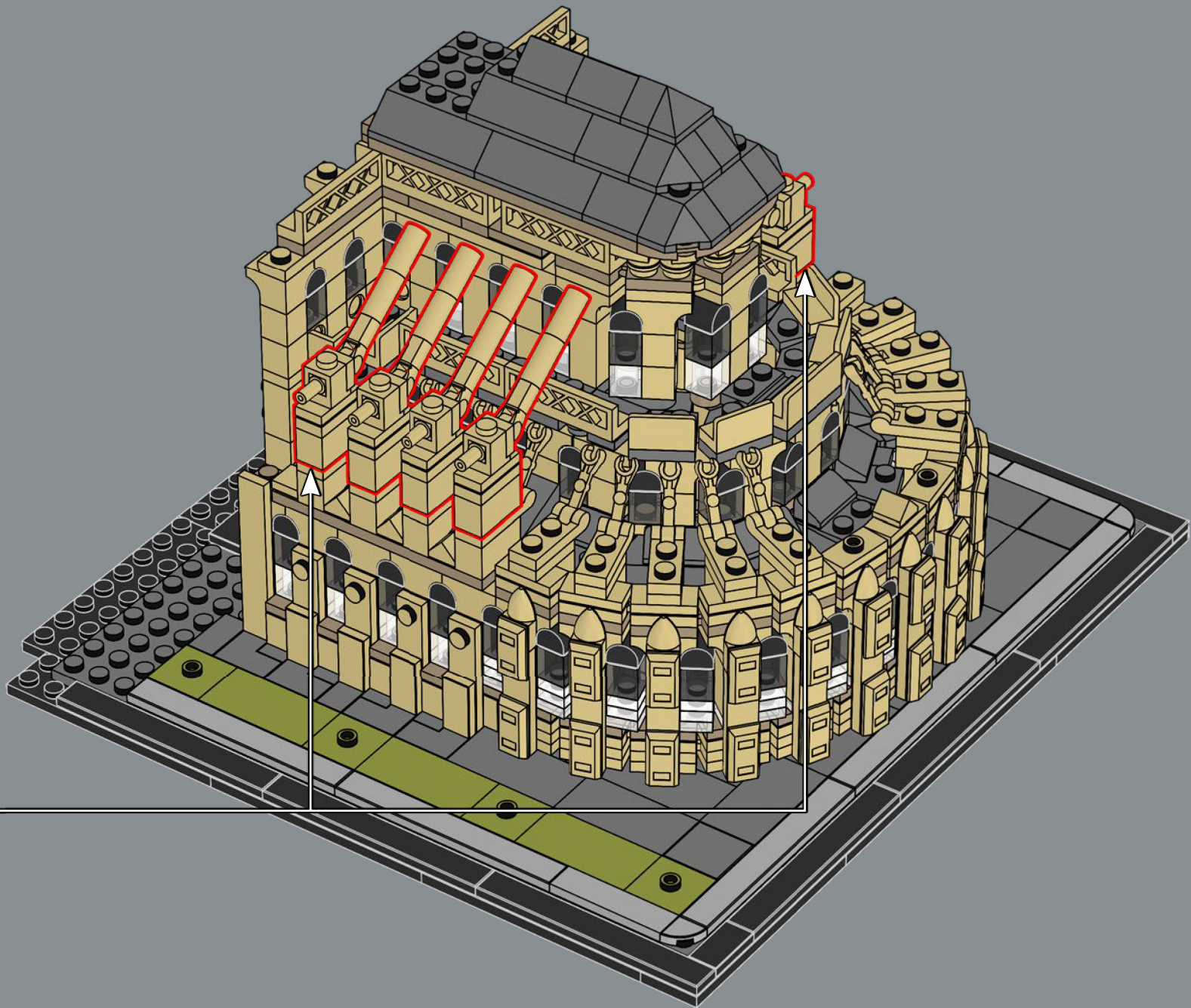

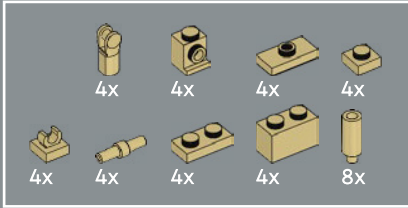
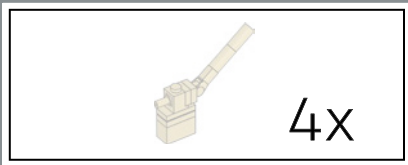

118

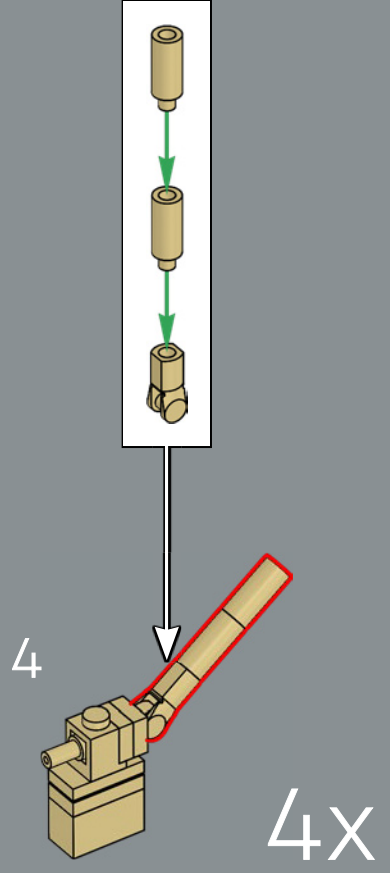
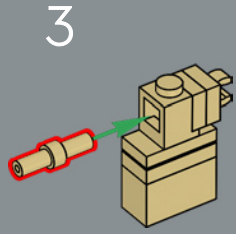
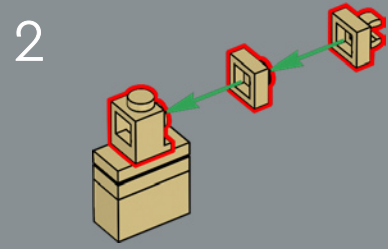
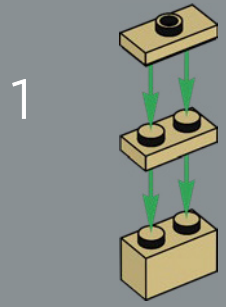

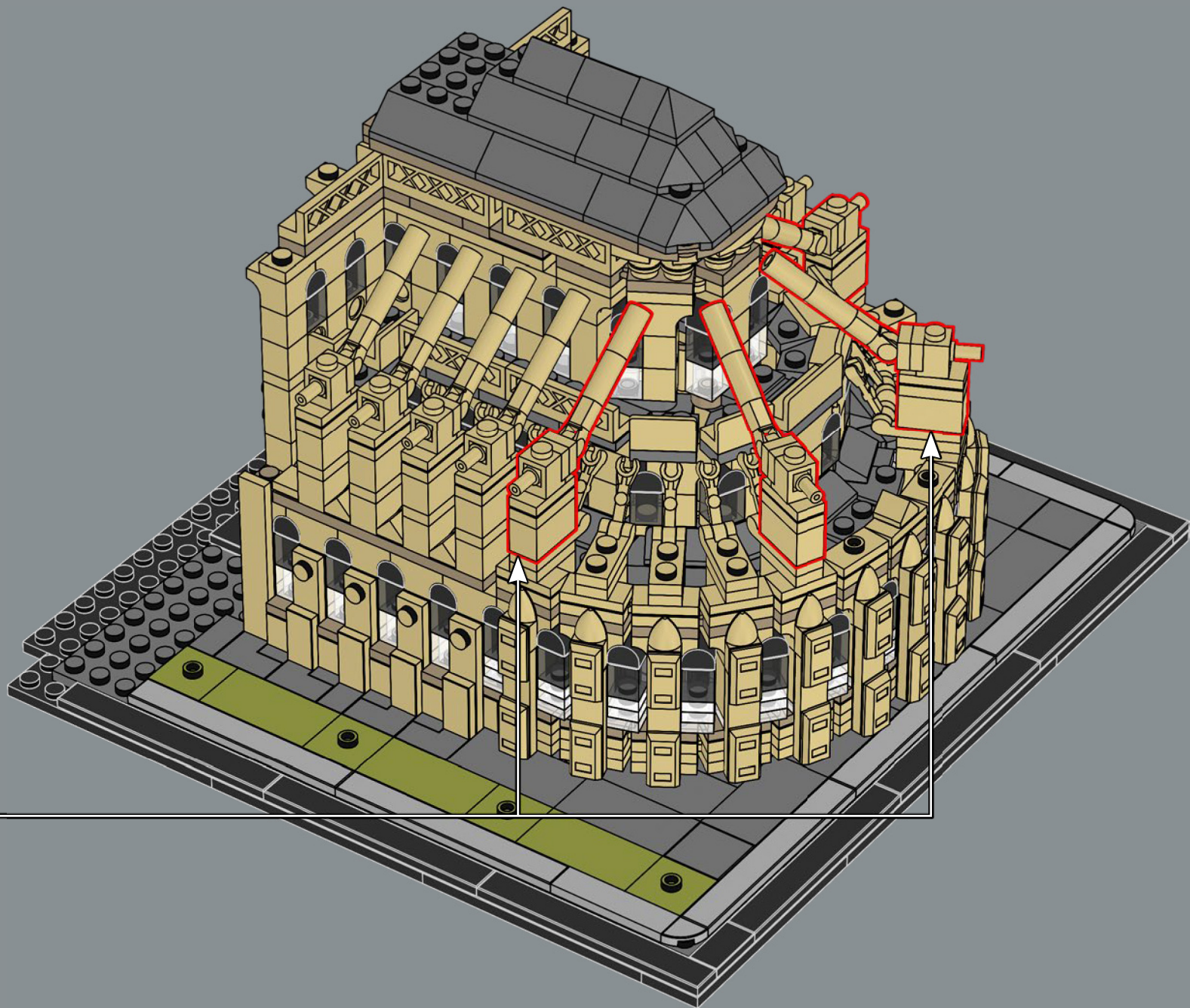

巴黎圣母院是第一座完全引入飞扶壁结构的大教堂，
飞扶壁是哥特式建筑的标志。

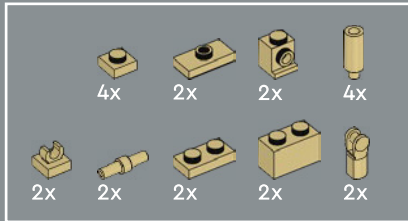
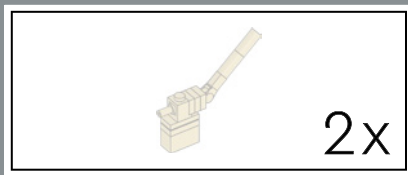

119

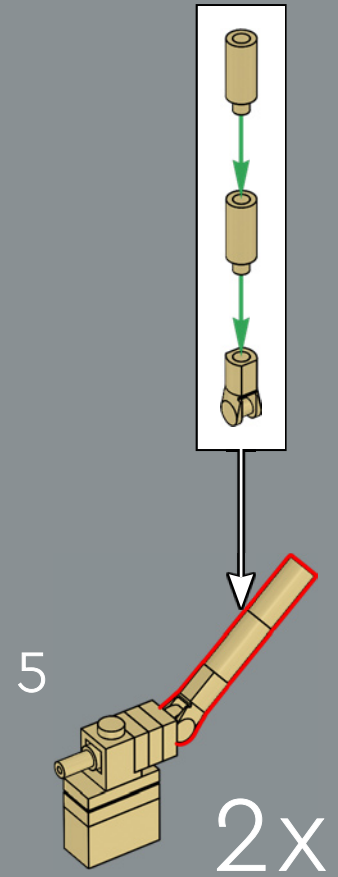
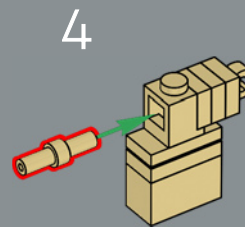
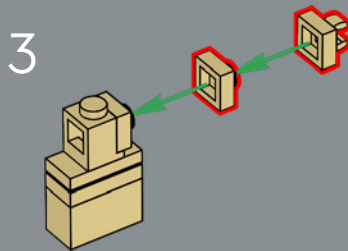
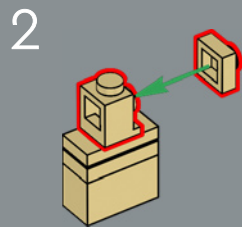
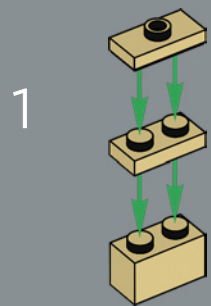

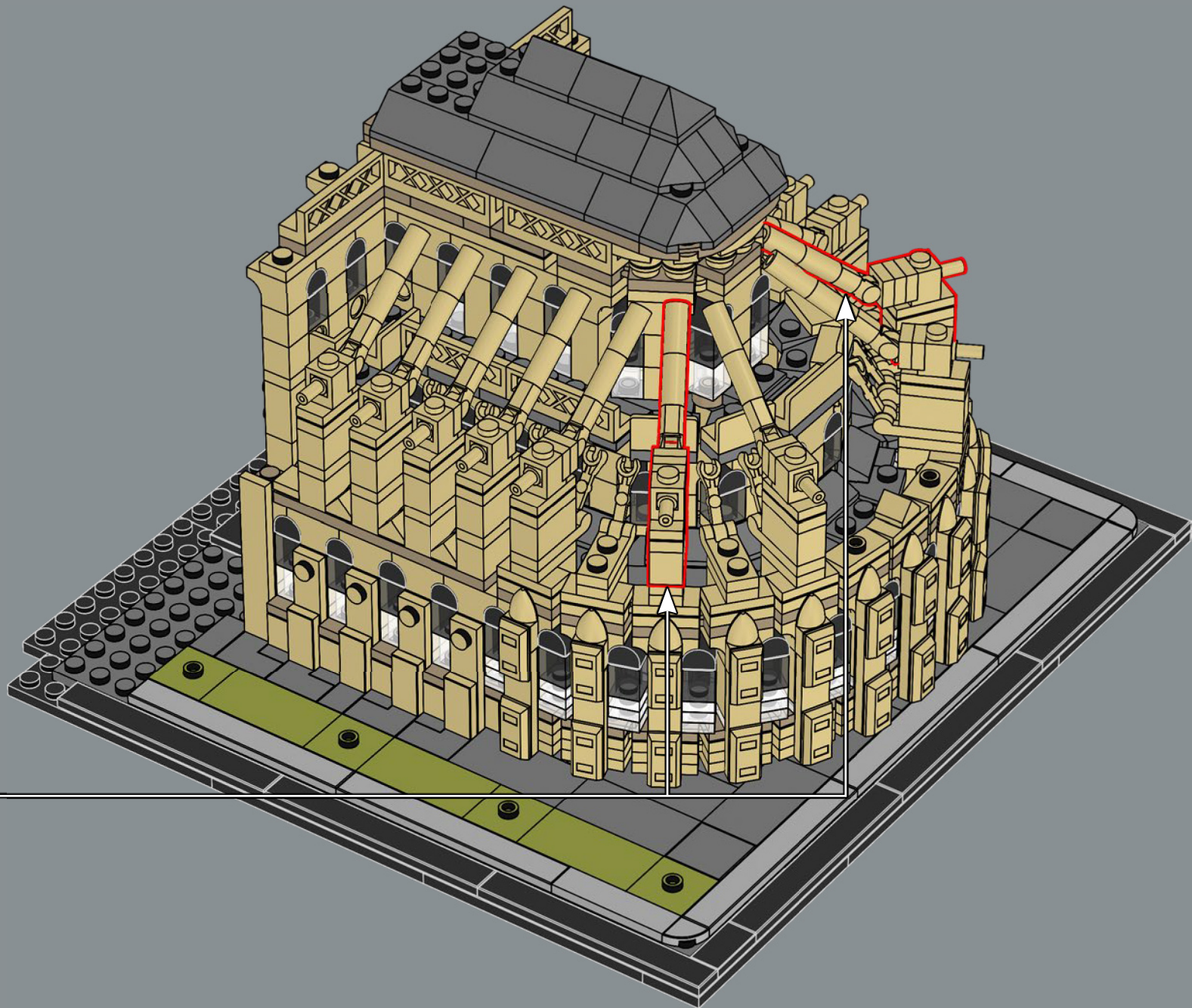

乐高®地标初具雏形

1182-1200 年



耳堂和中堂南侧的隔间在继续建造中。

巴黎圣母院建在塞纳河西岱岛已有大教堂的遗址上，长 128 米（419.9 英尺）、宽 48 米（157.4 英尺）和高 69 米（226.3 英尺）。首先完工的东侧部分被用作临时教堂，耳堂和中堂南侧的第一批隔间的建设工作仍在继续。该建筑逐渐融入了当代建筑风格，从最初的罗马式建筑风格演变成今天所代表的哥特式风格。本模型忠实于这座大教堂的内部结构和外部建筑细节（某些特征和功能按比例缩小），以重现几个世纪以来令游客惊叹和敬畏的景观。

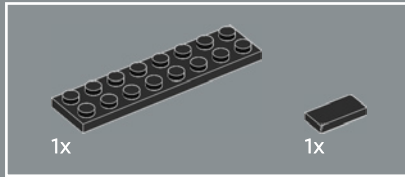
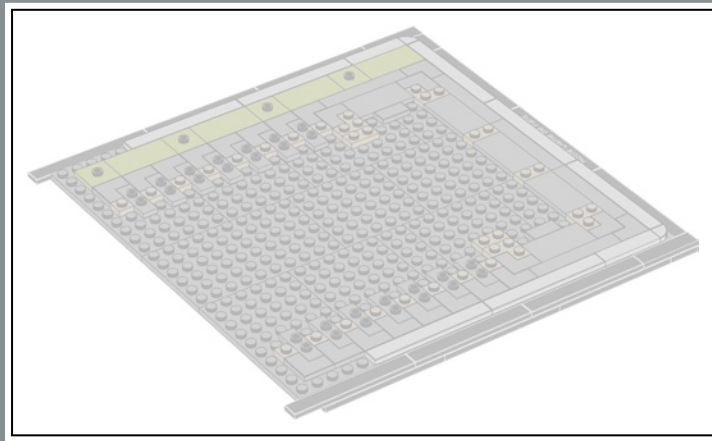

120

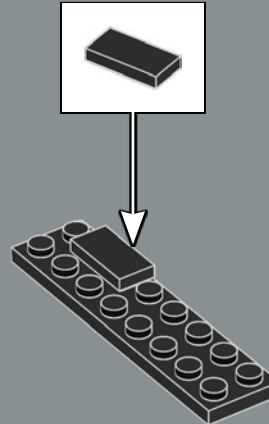

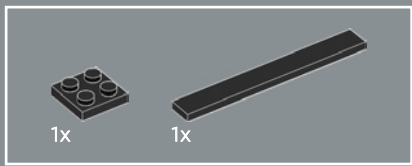

121

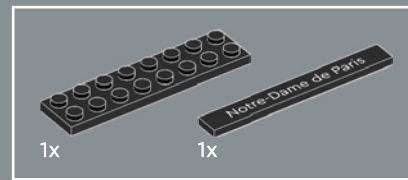
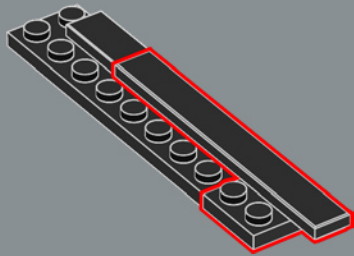

122

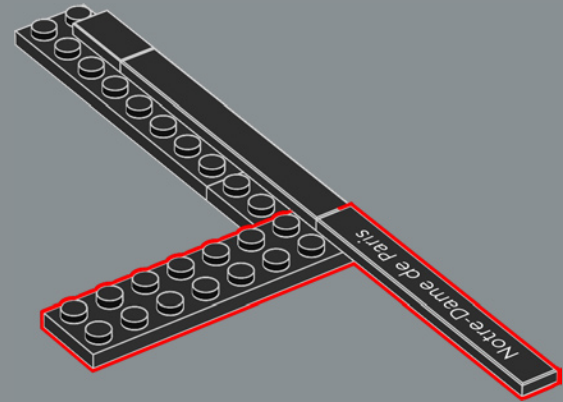

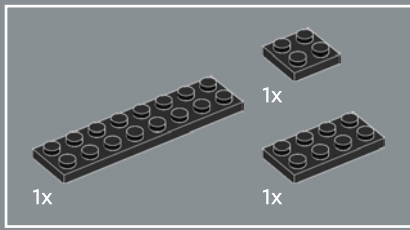

123

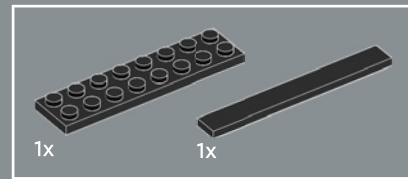
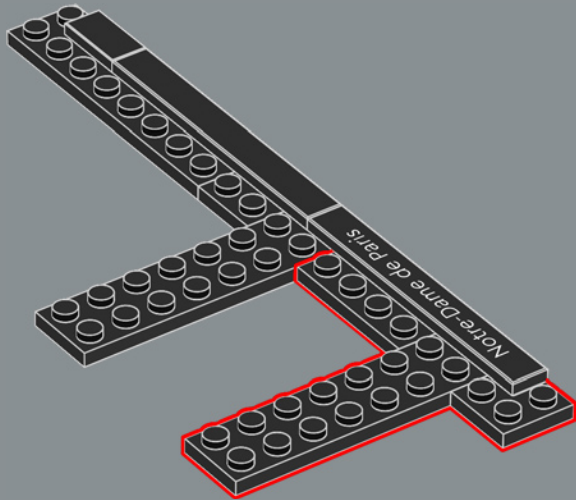

124

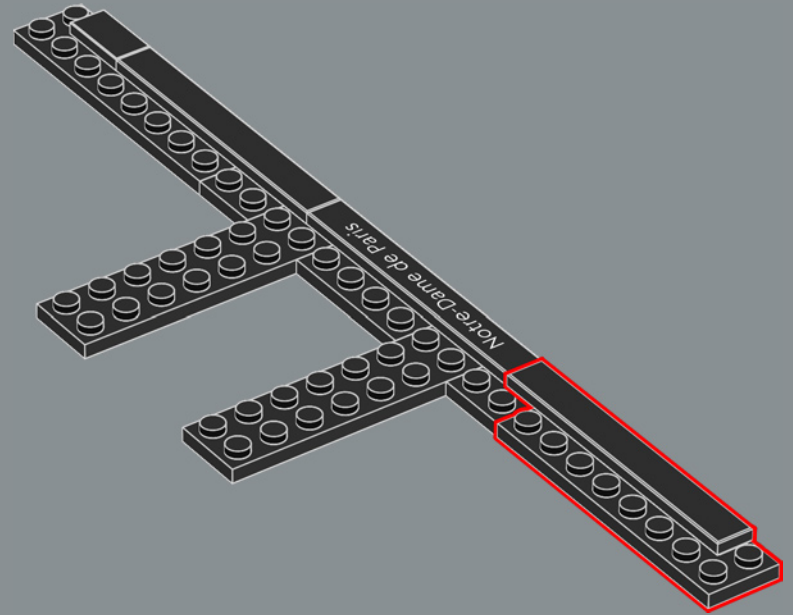

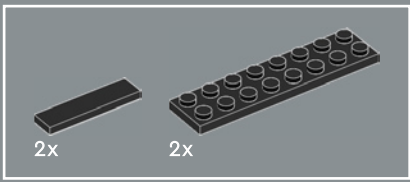

125

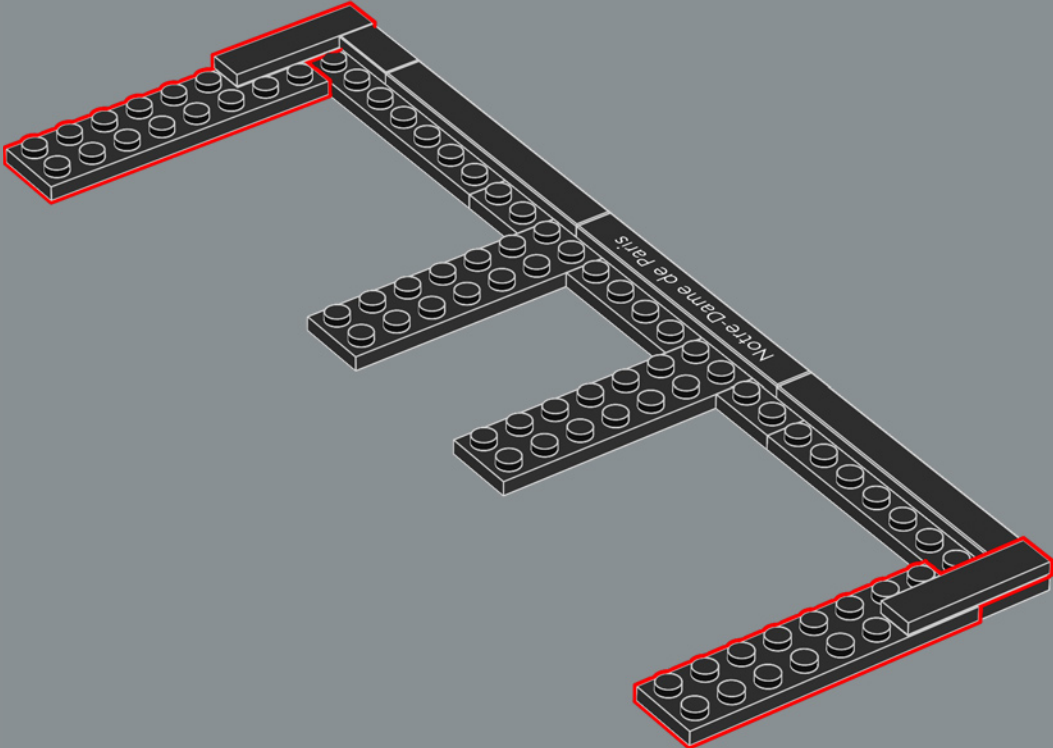

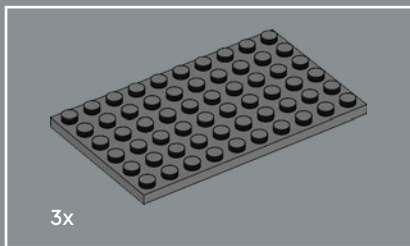

126

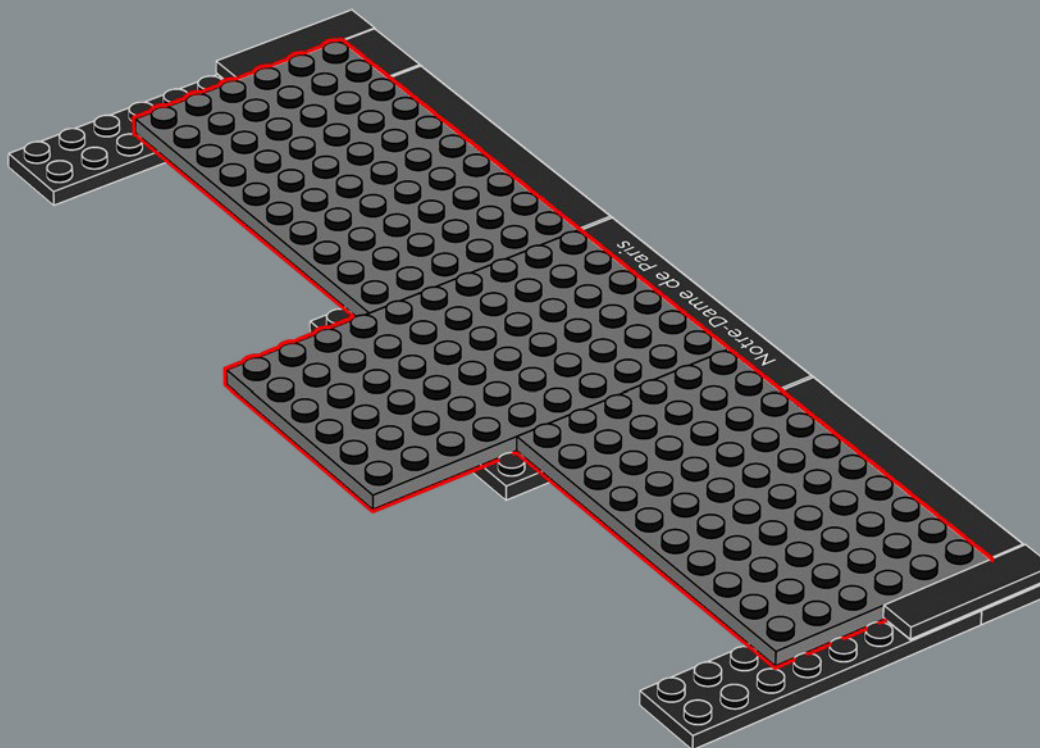

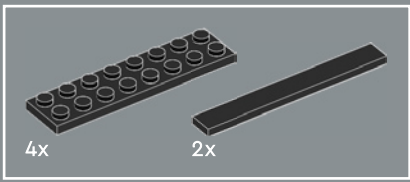

127

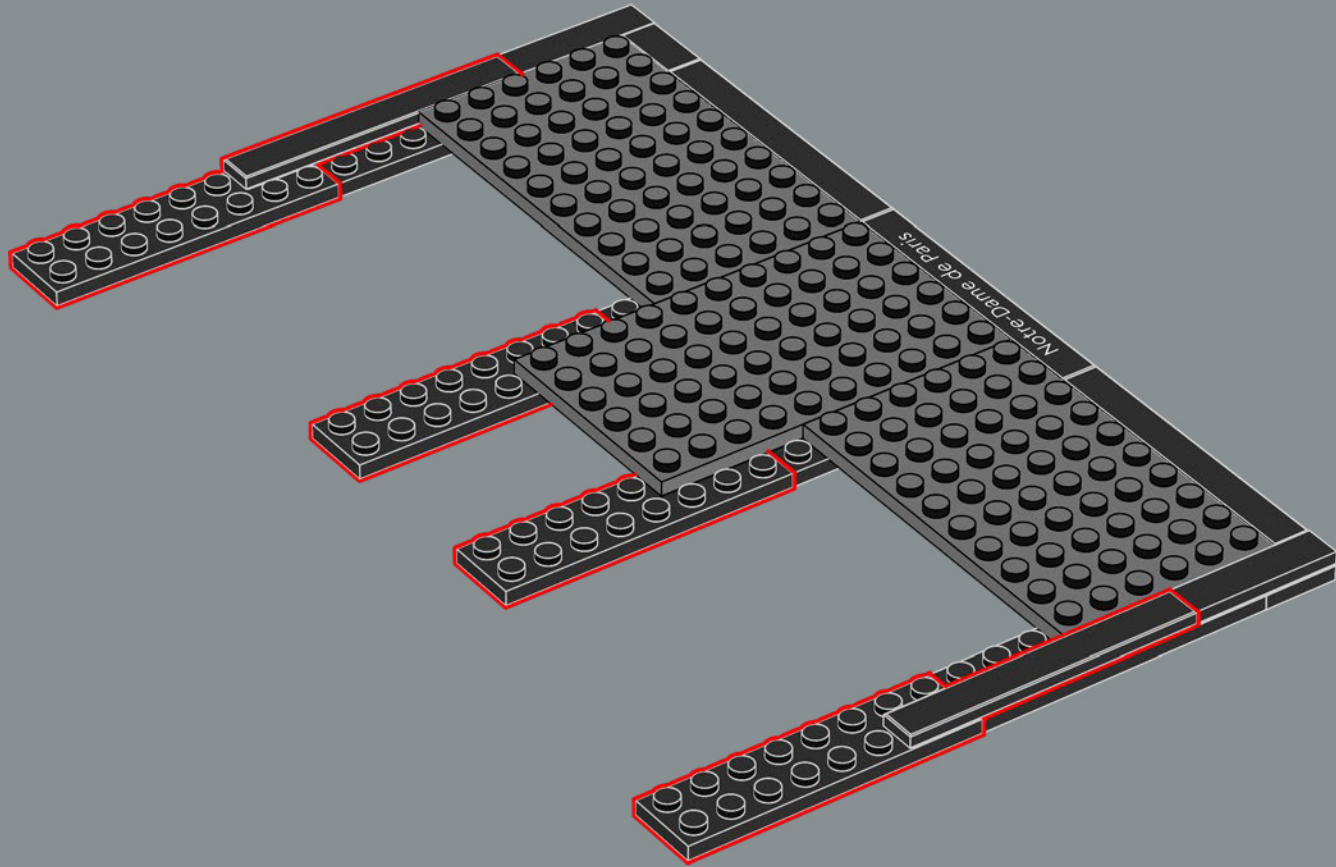

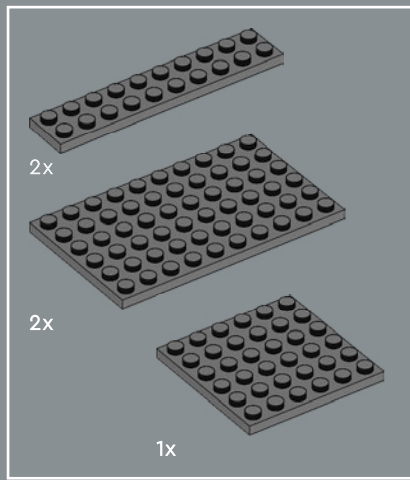

128

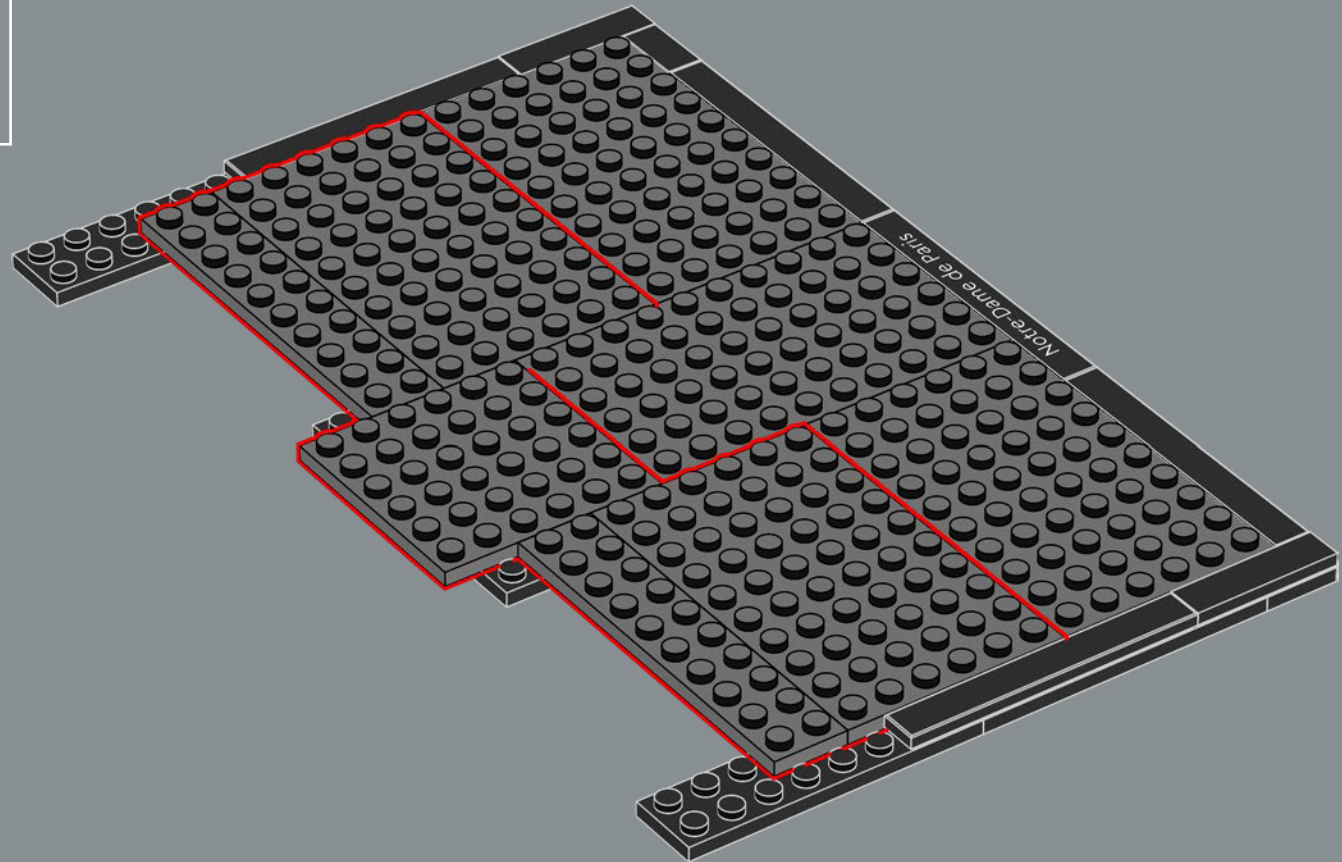

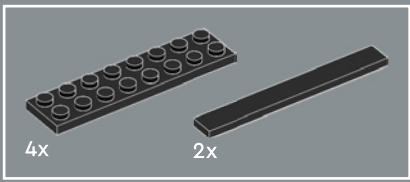

129

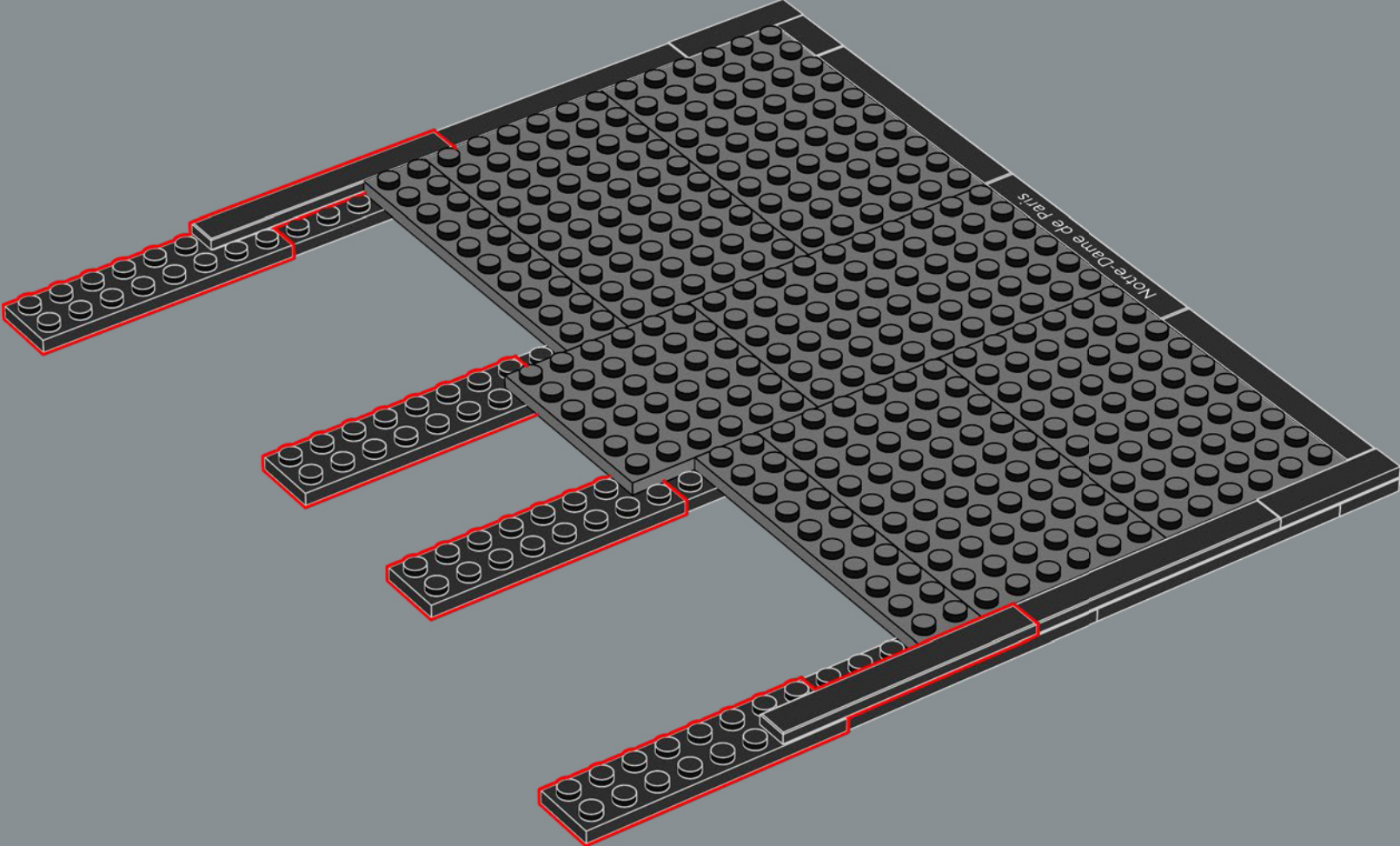

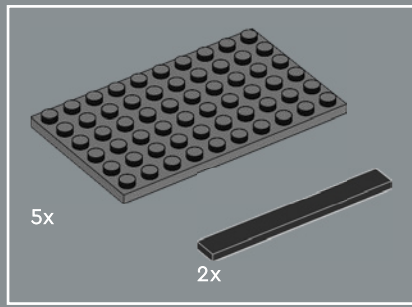

130

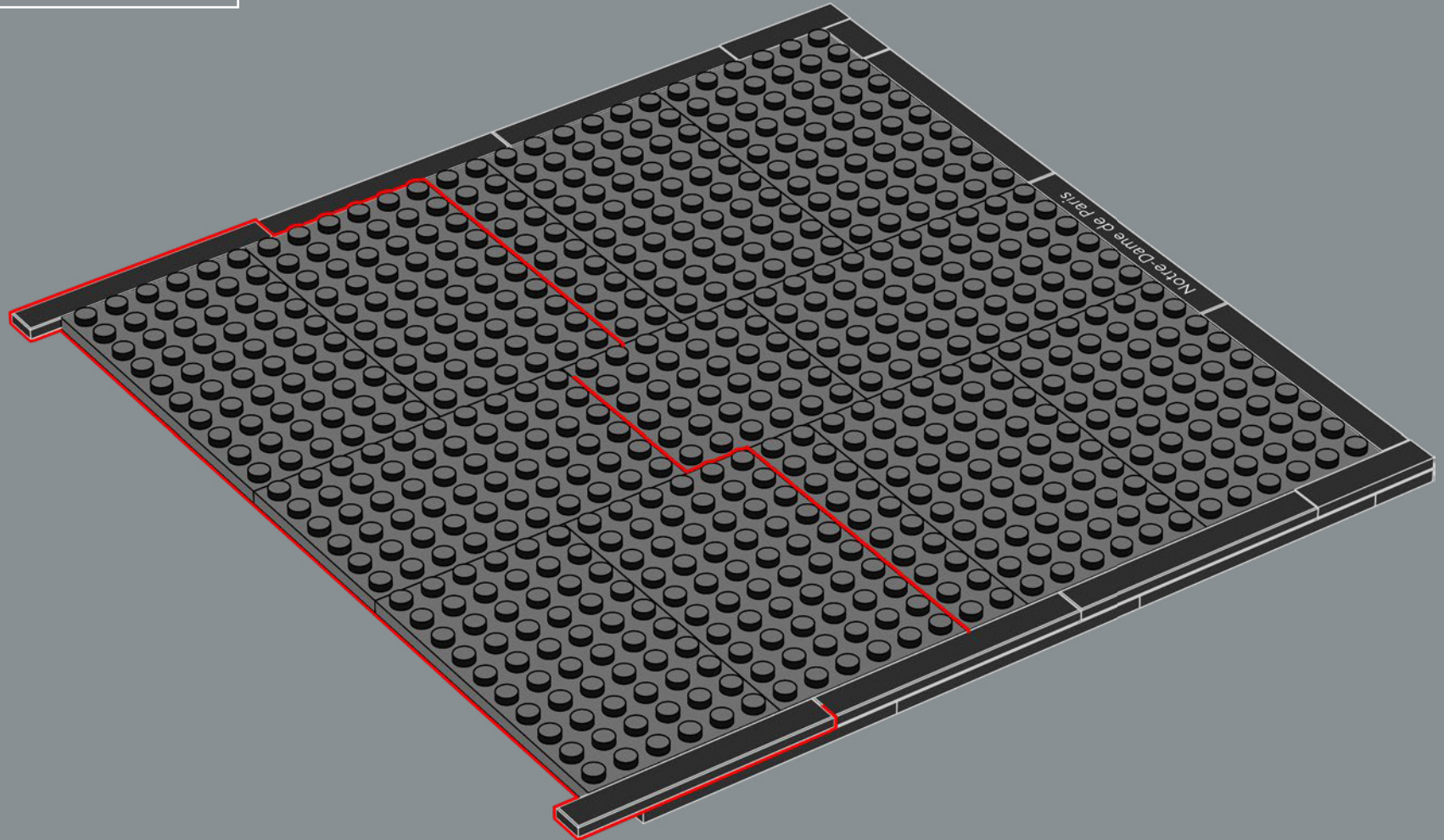

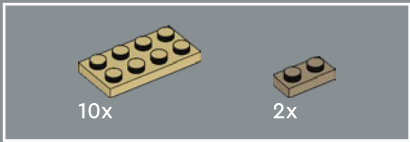

131

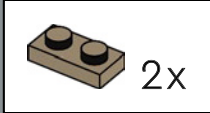
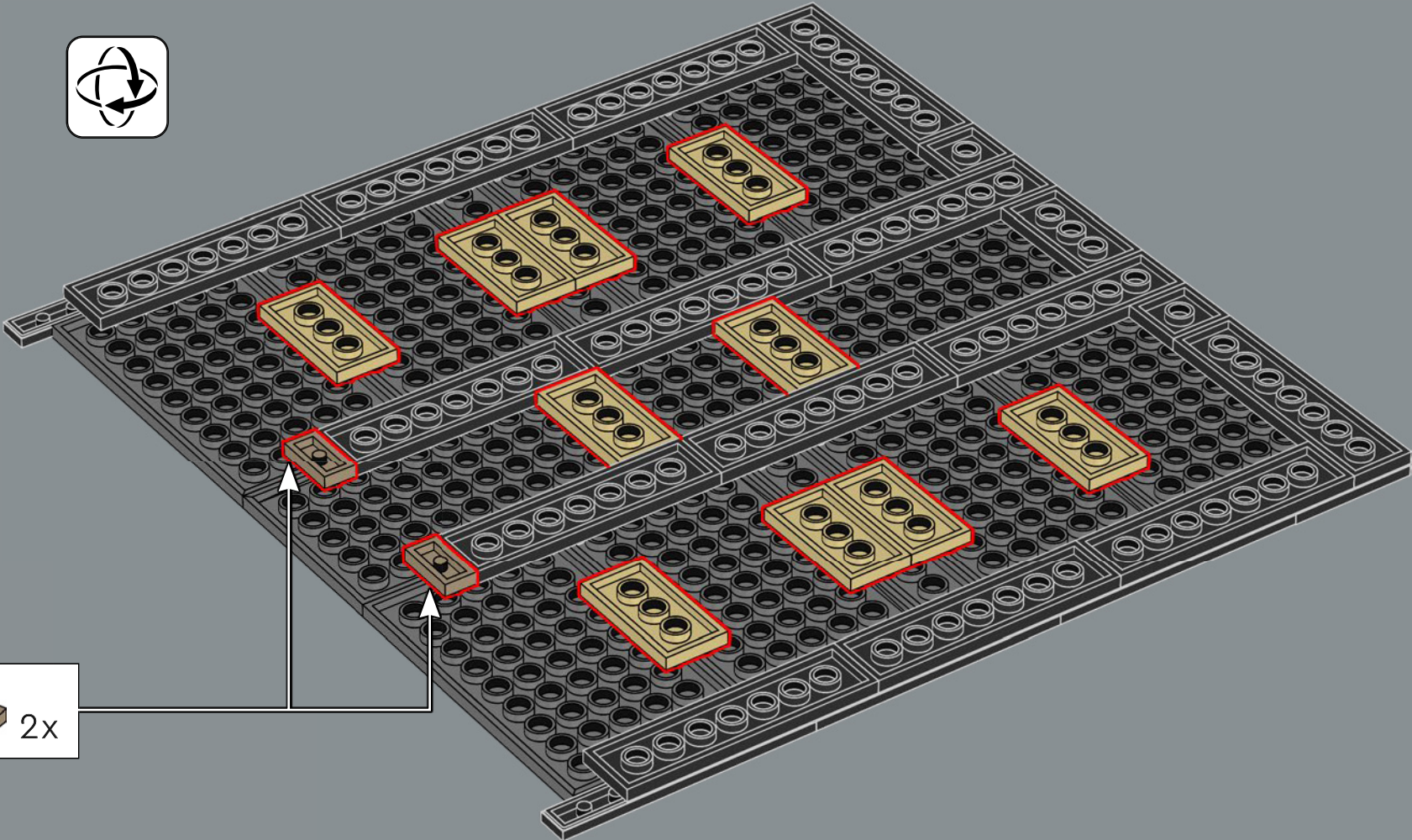

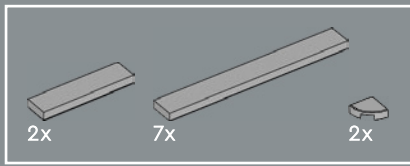

132

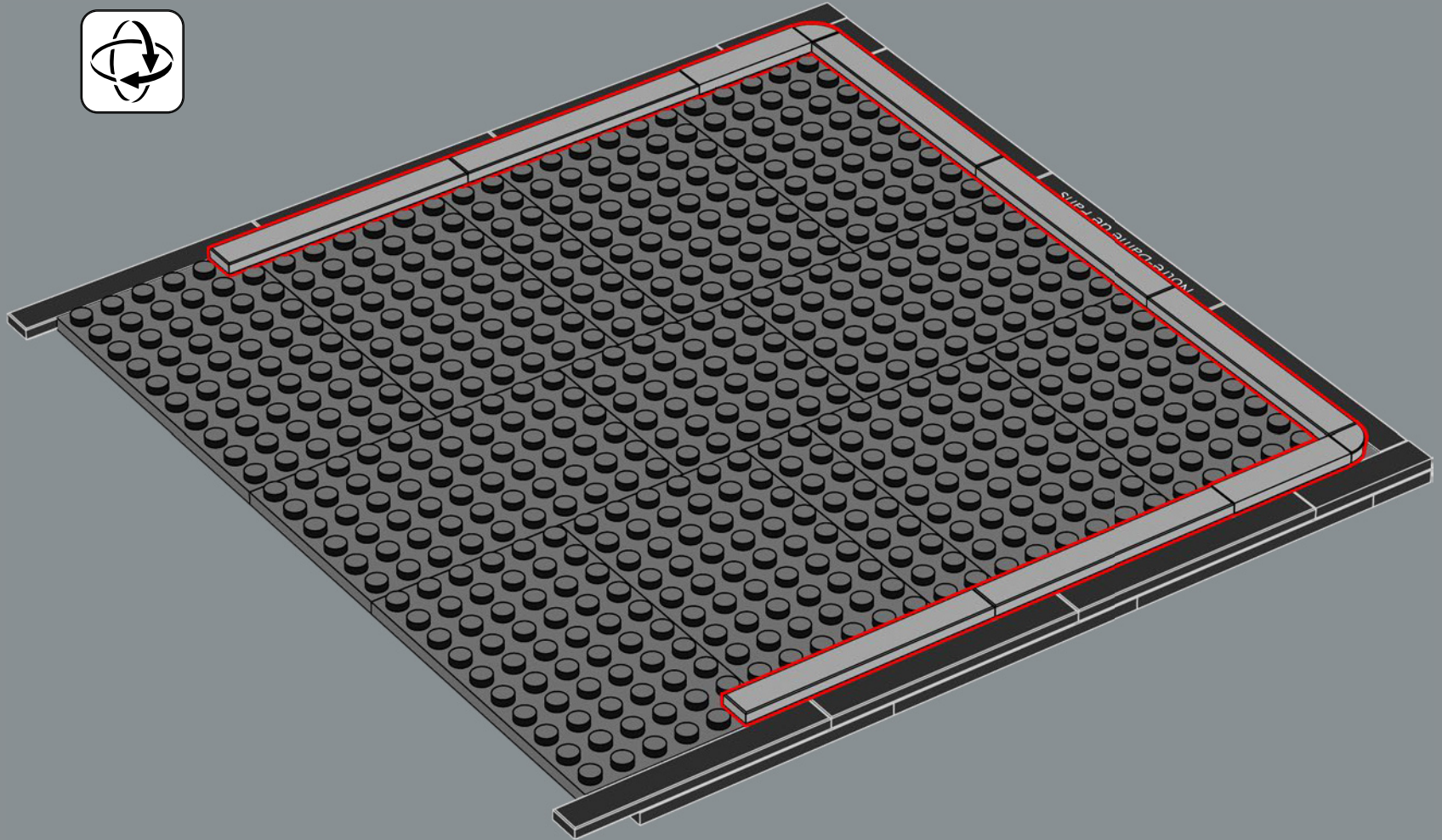

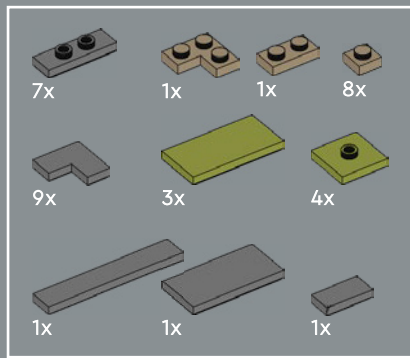

134

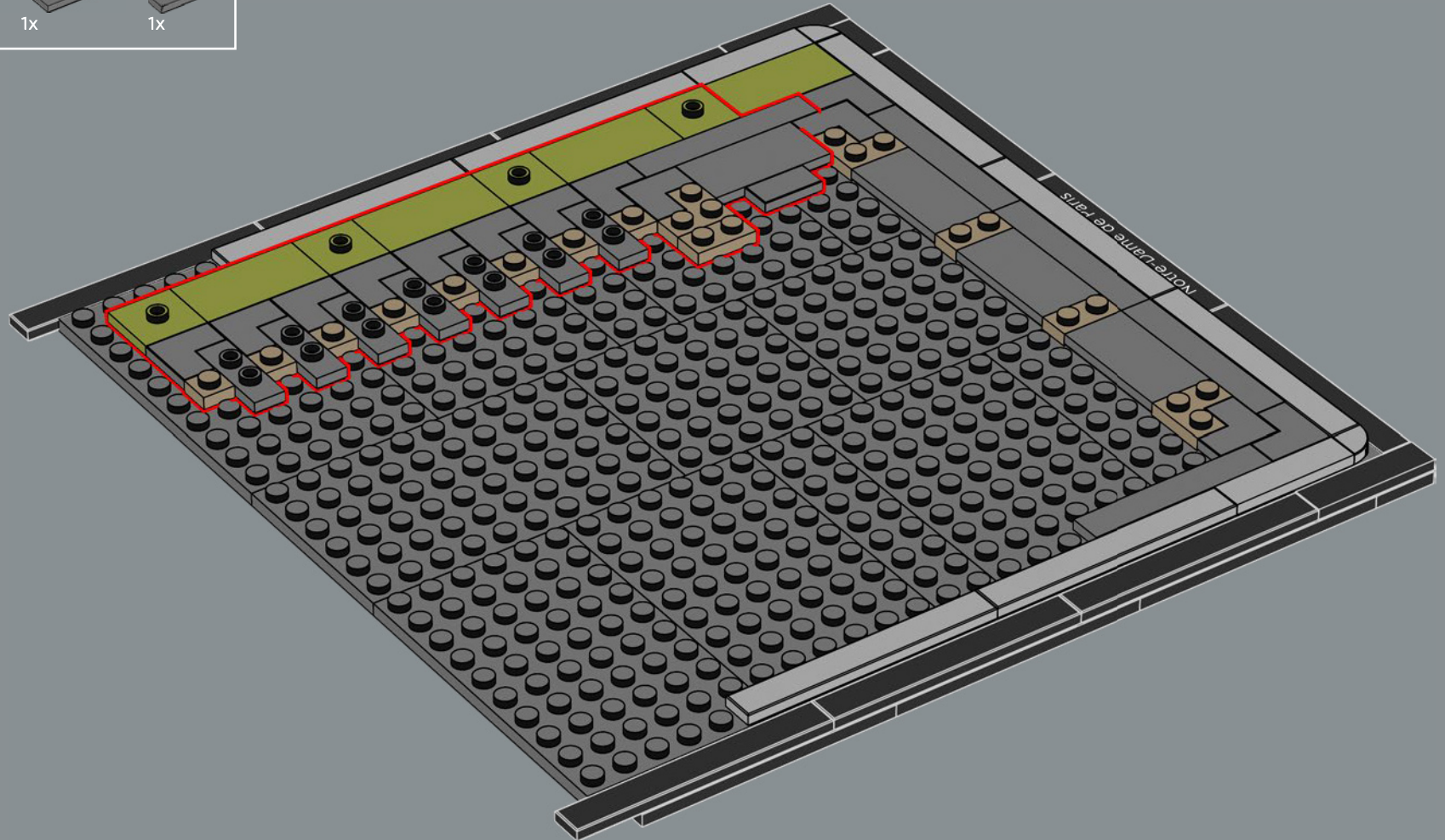

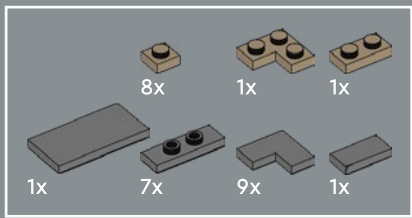

135

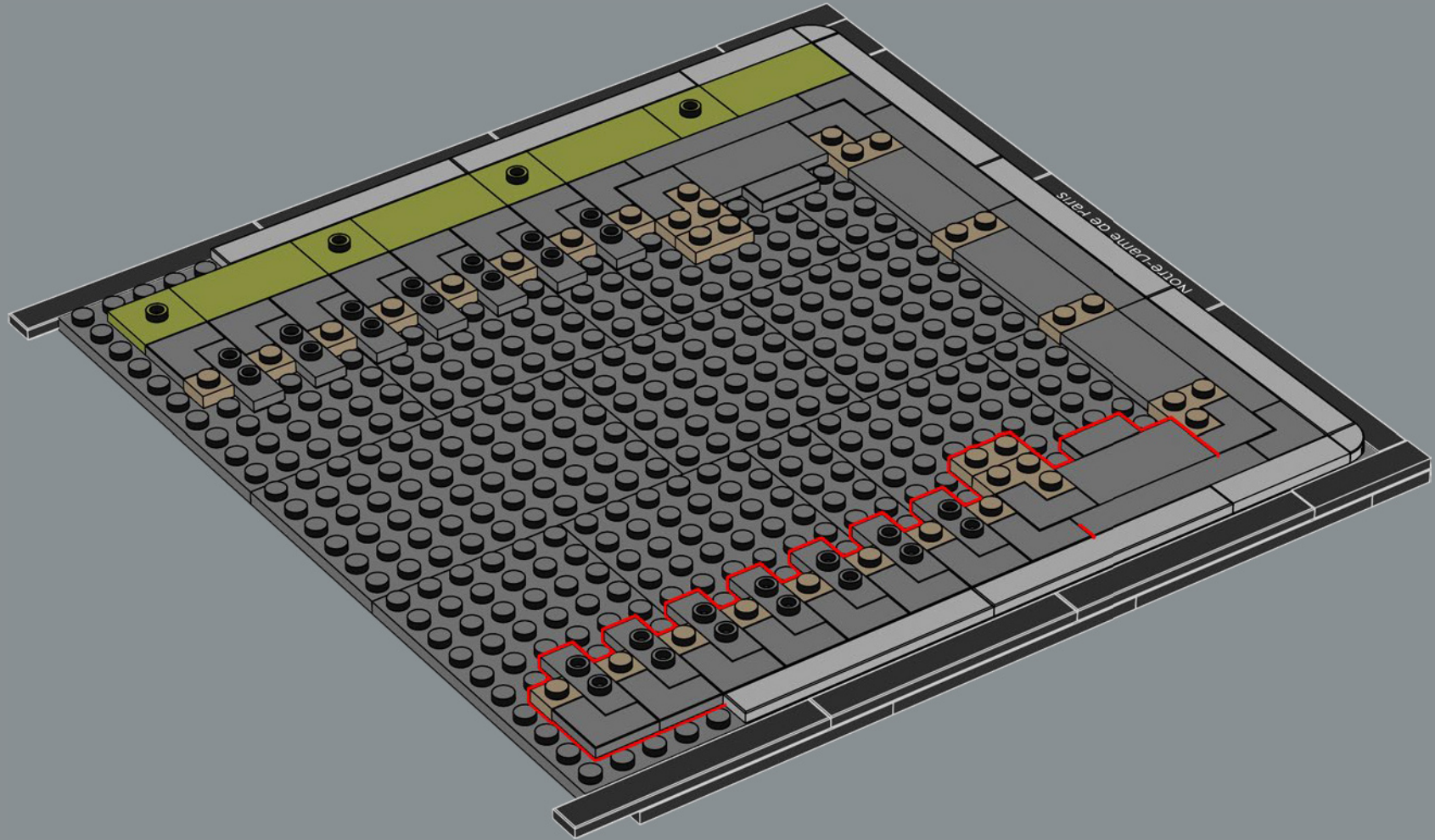

136

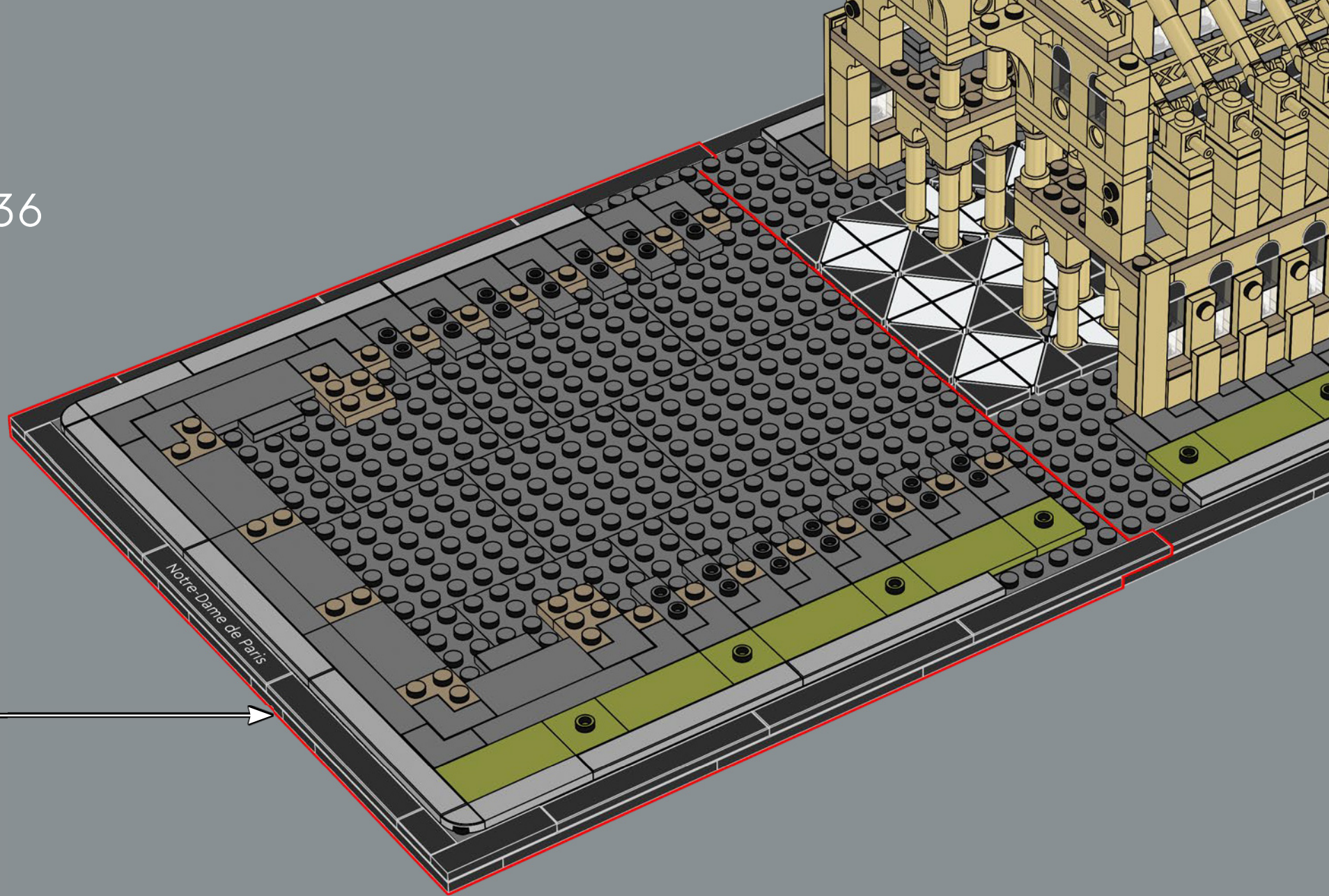

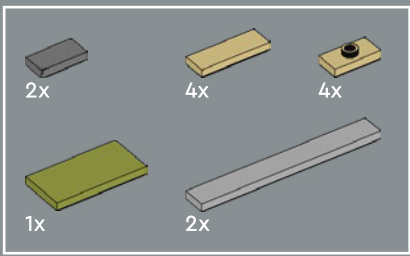

137

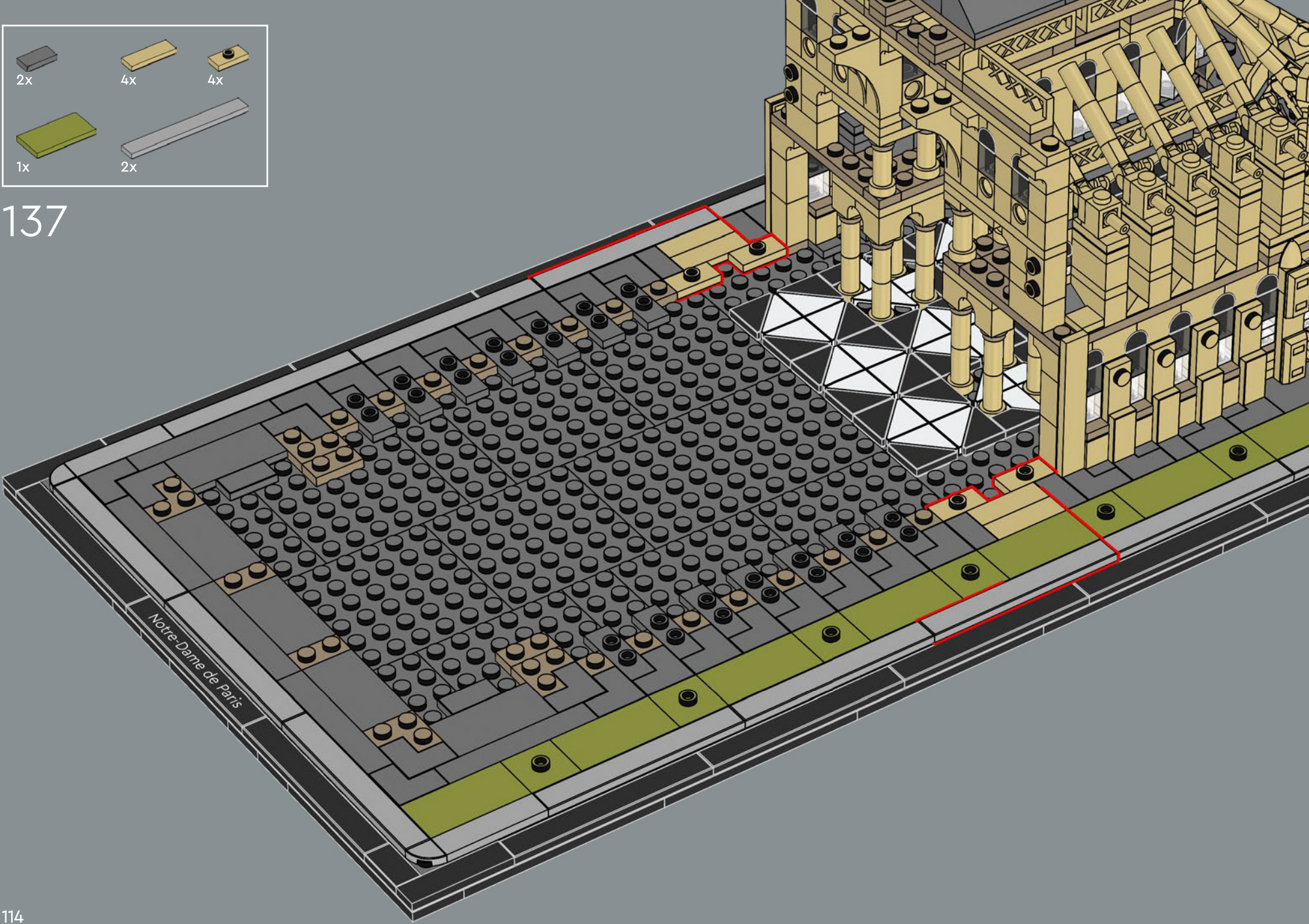

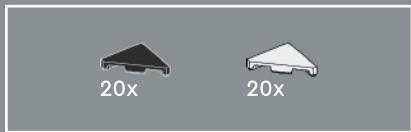

138

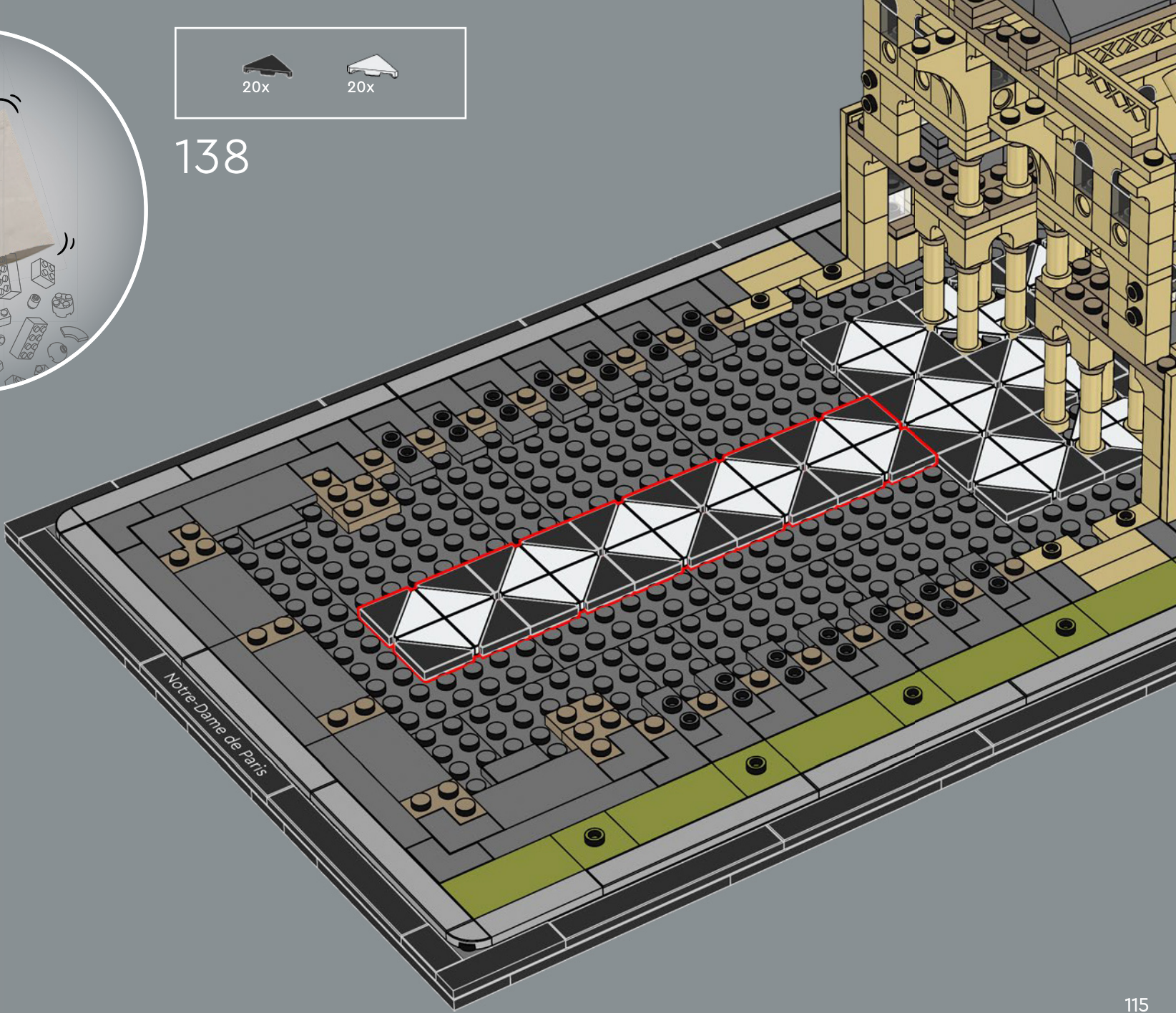

2x 30x

139

30x

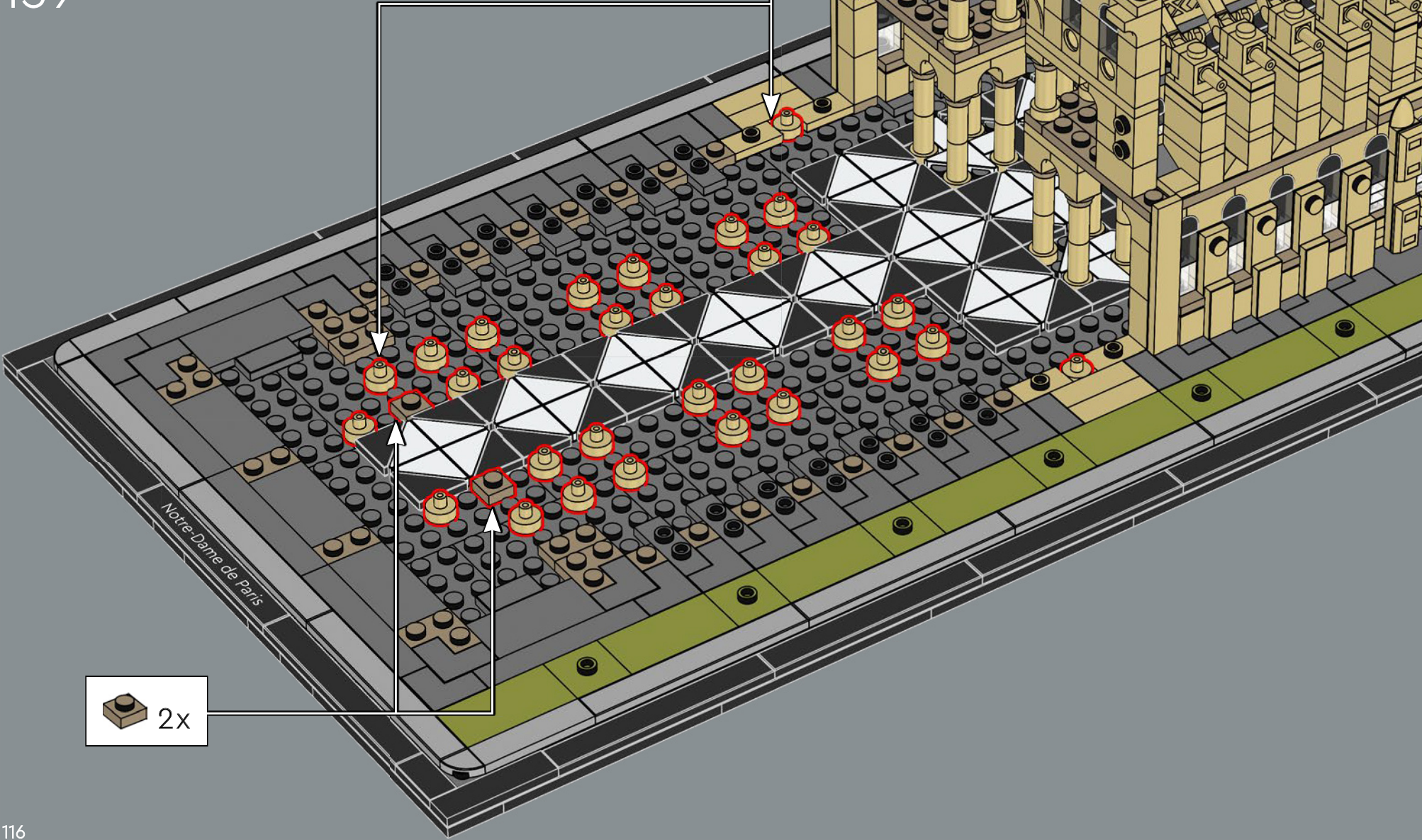

2x

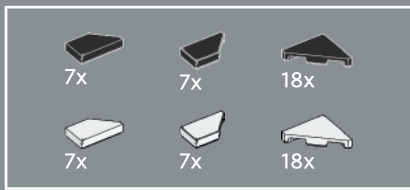

140

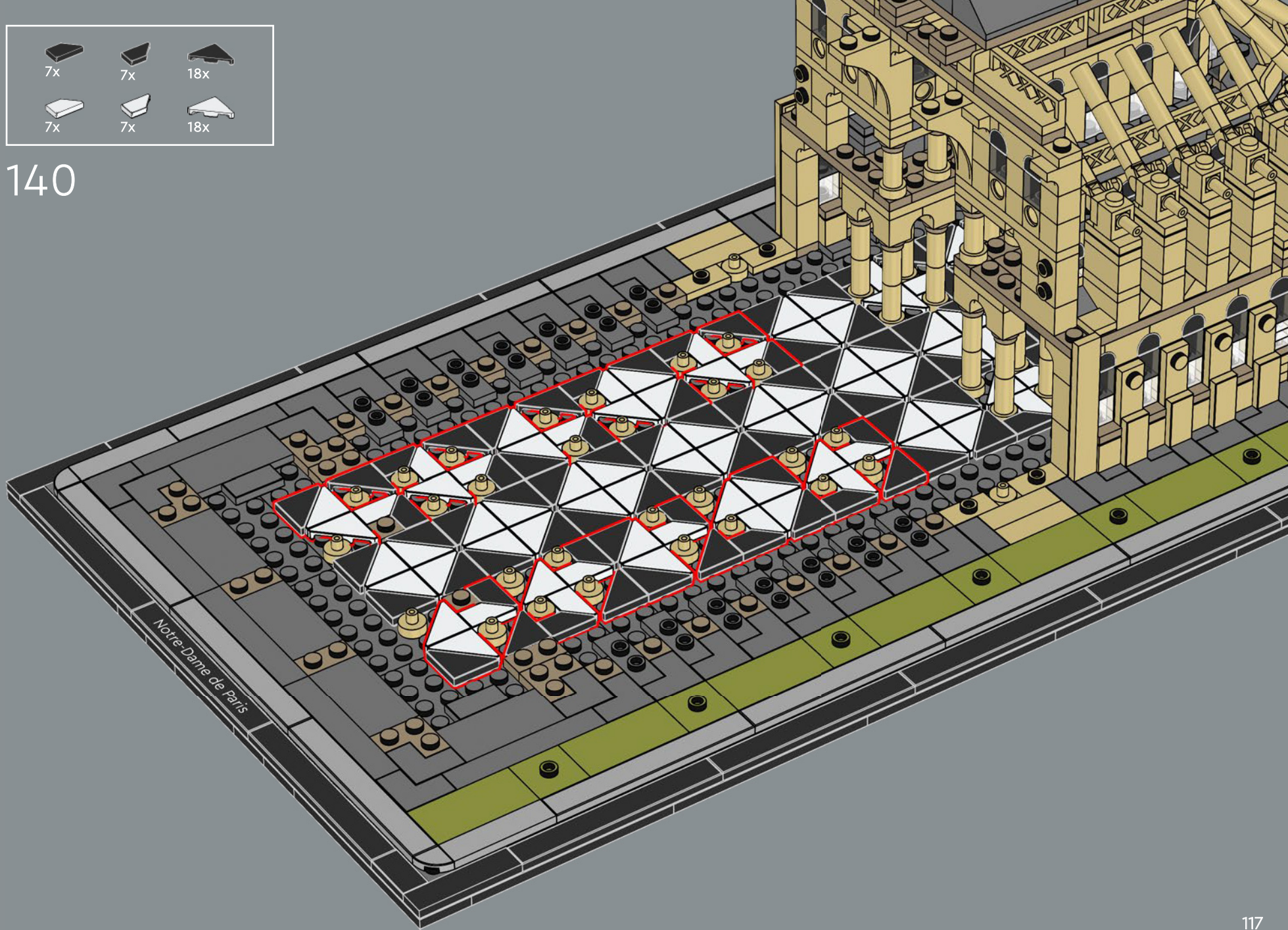



141

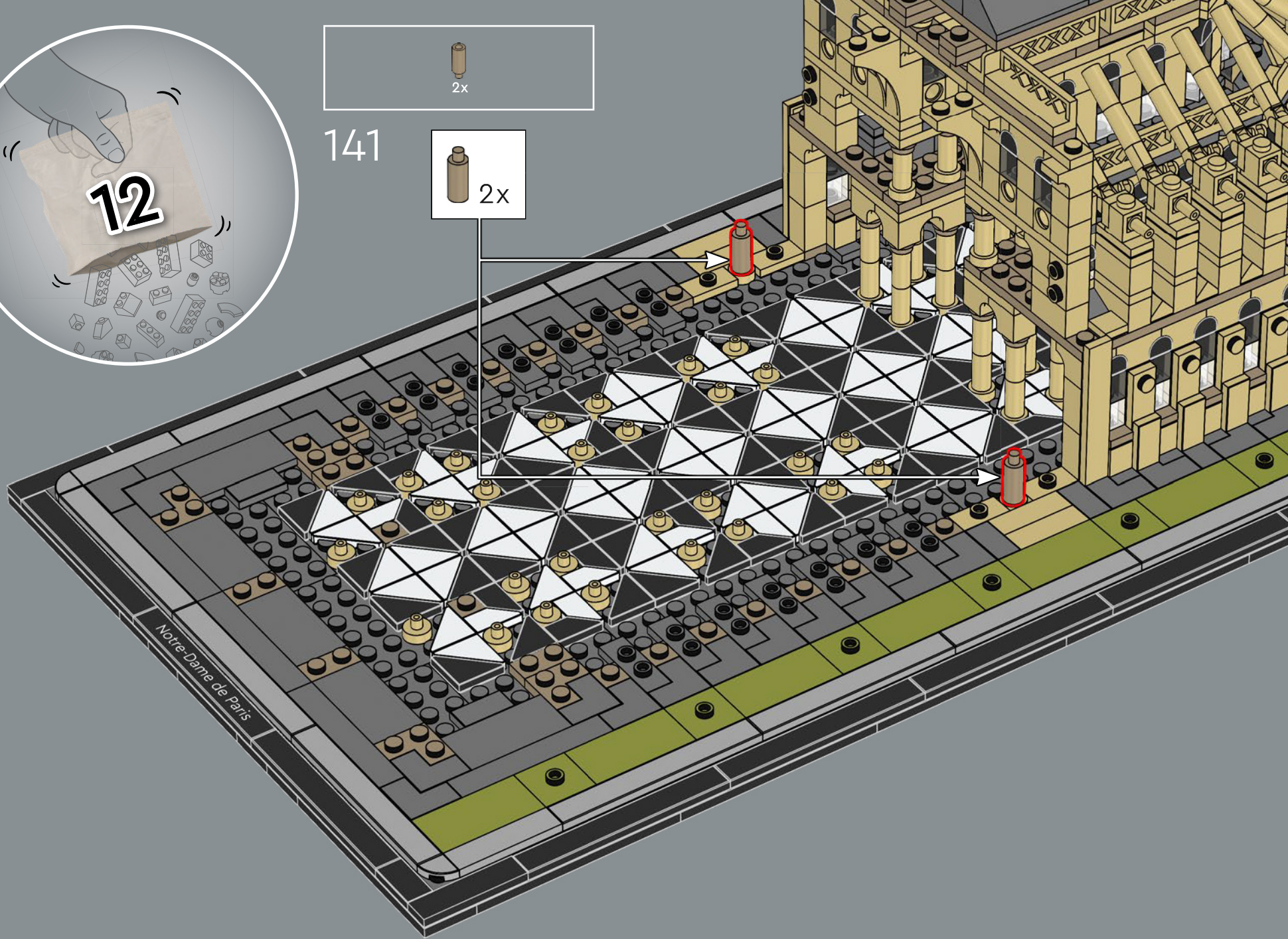
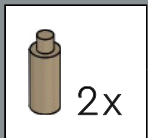

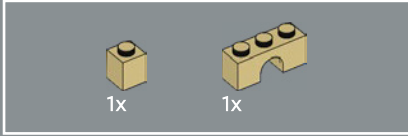
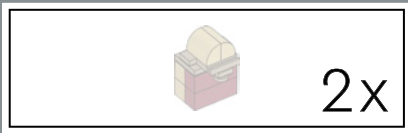

142

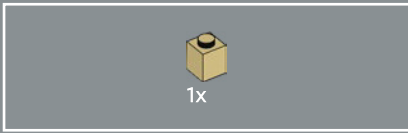
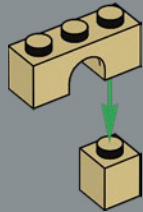

143

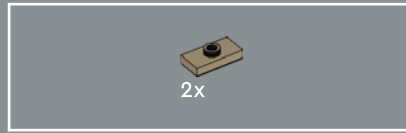
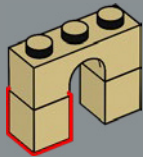

144

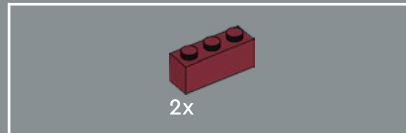
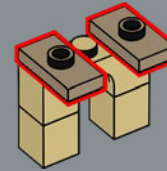

145

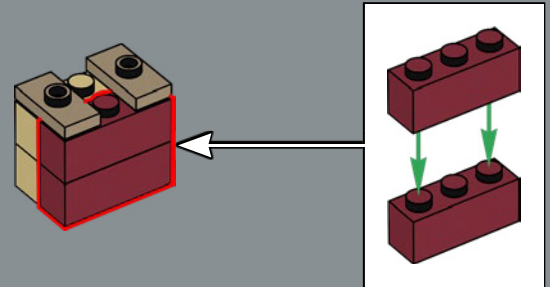

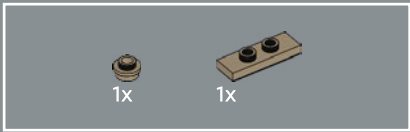

146

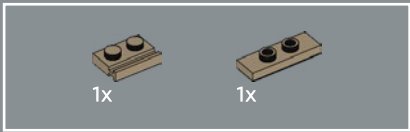
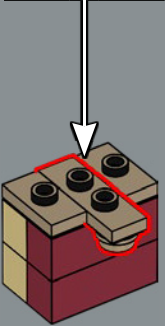
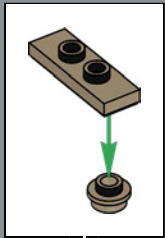

147

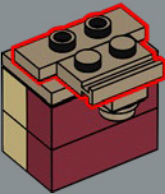

148

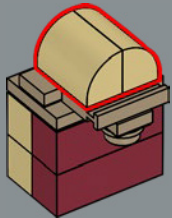

2x

149

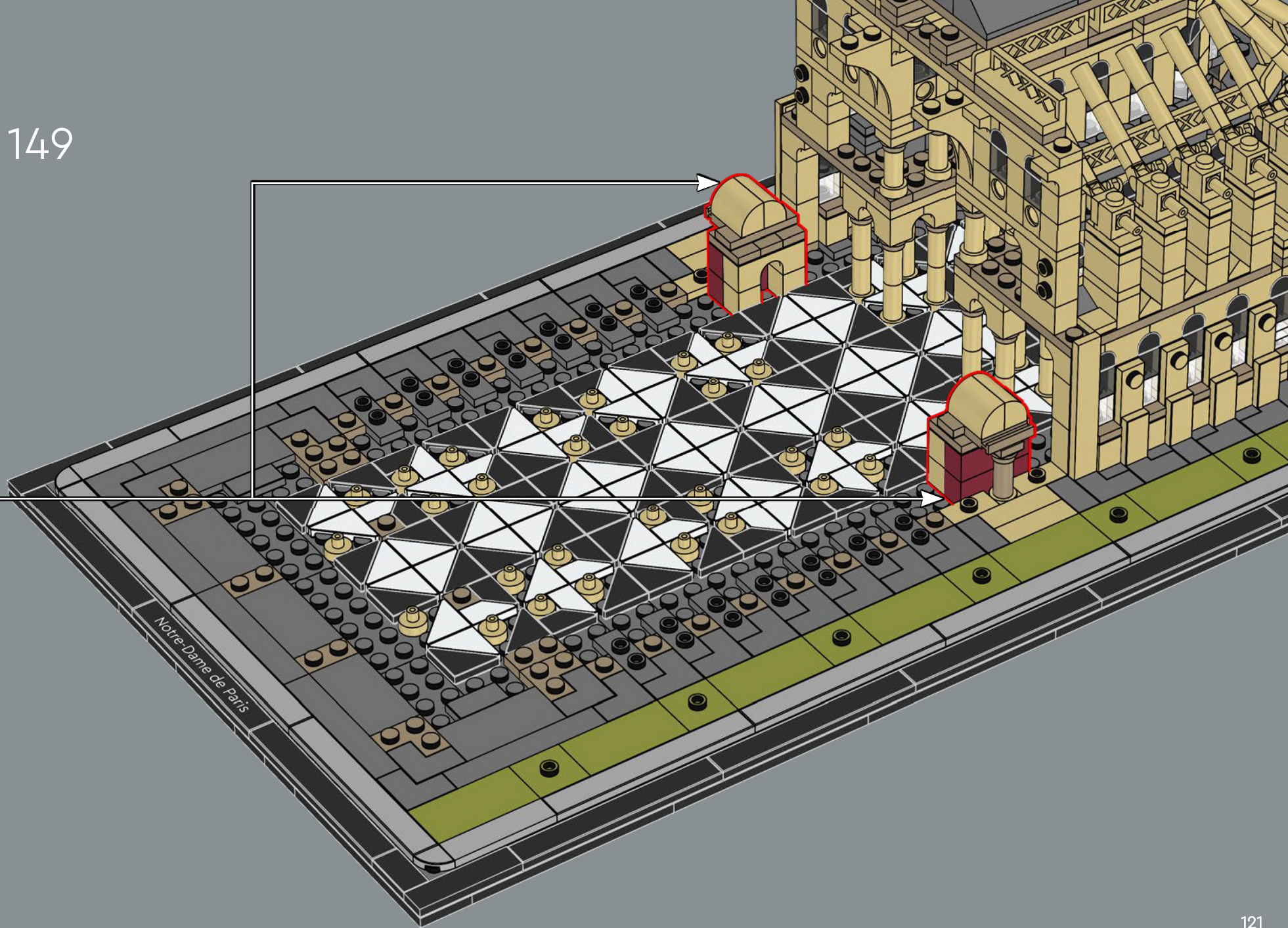

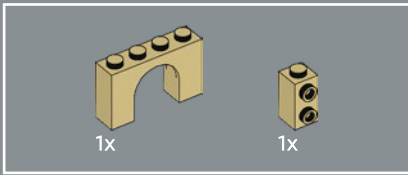
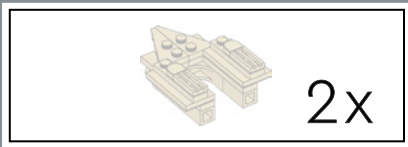

150

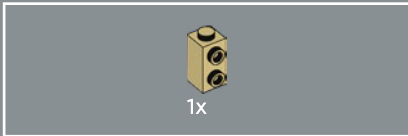
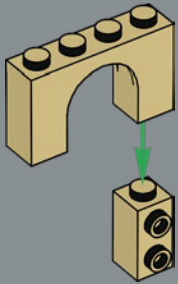

151

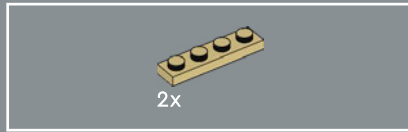
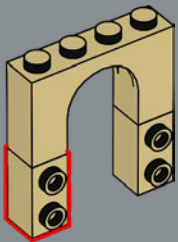

152

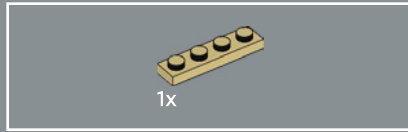
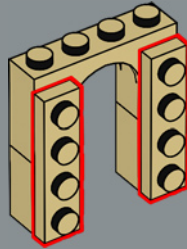

153

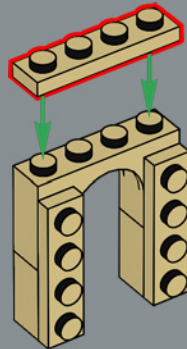

154

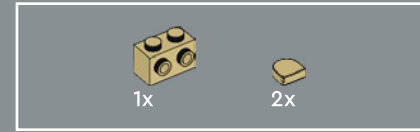
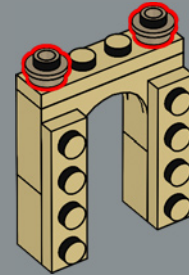

155

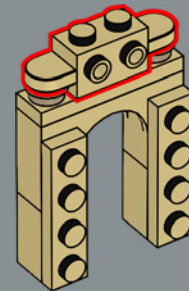

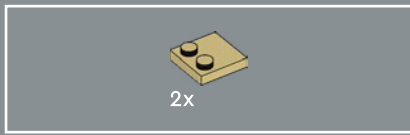

156

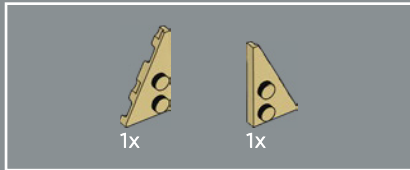
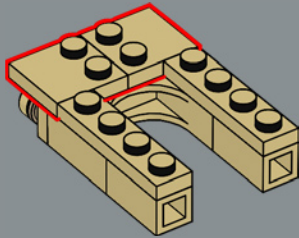

157

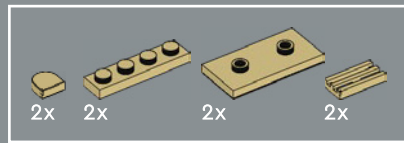
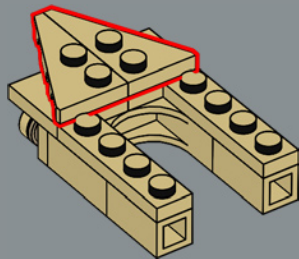

158

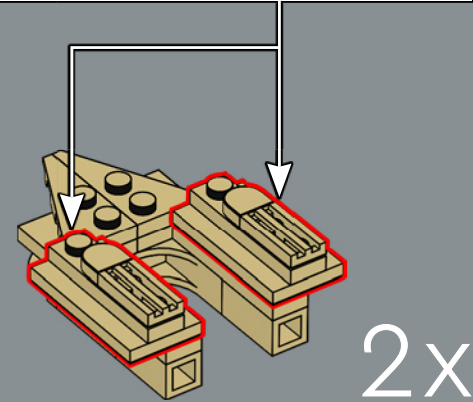
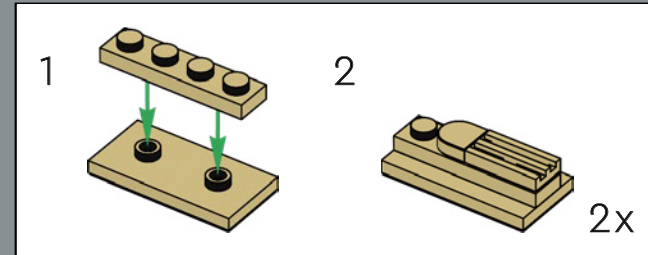

1182 年——唱诗堂与繁忙的建筑工地被一道临时的墙隔开。
耳堂和中堂的施工从东到西继续进行。

159

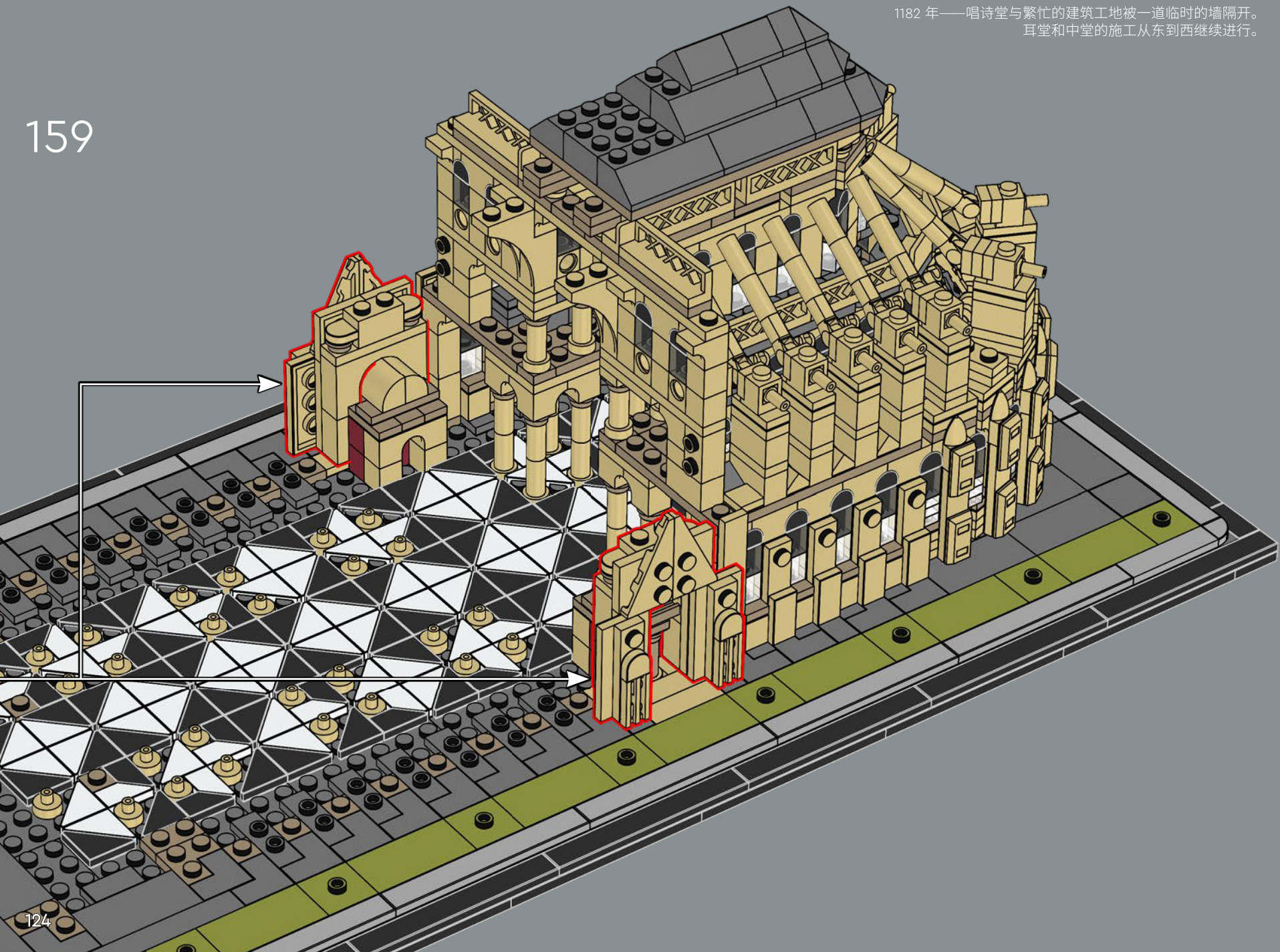

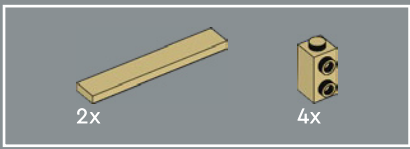

160

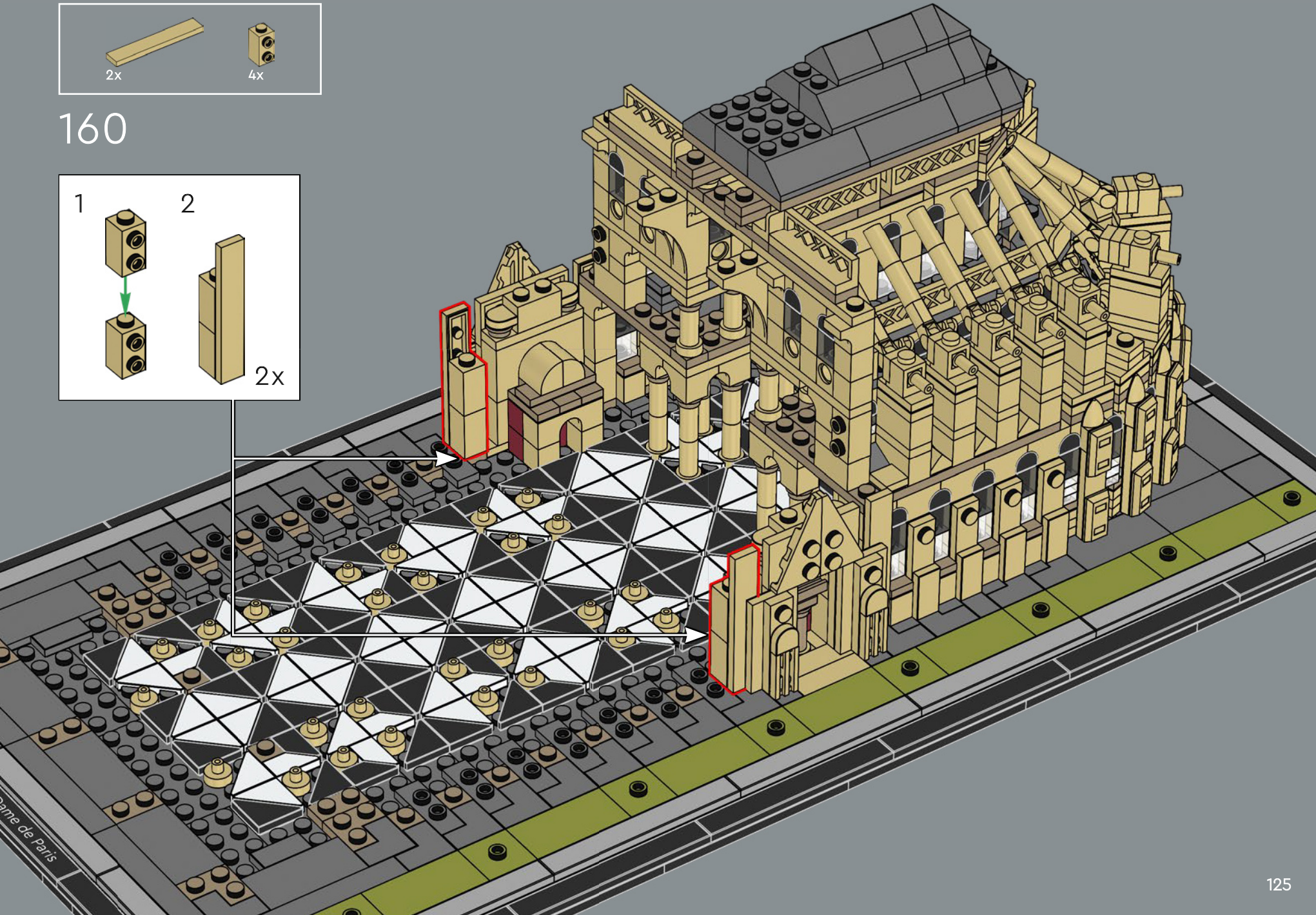
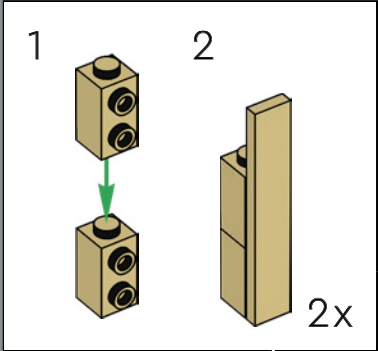

Paris de Paris

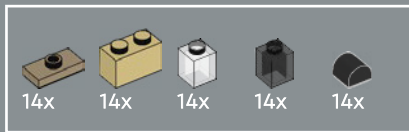

161

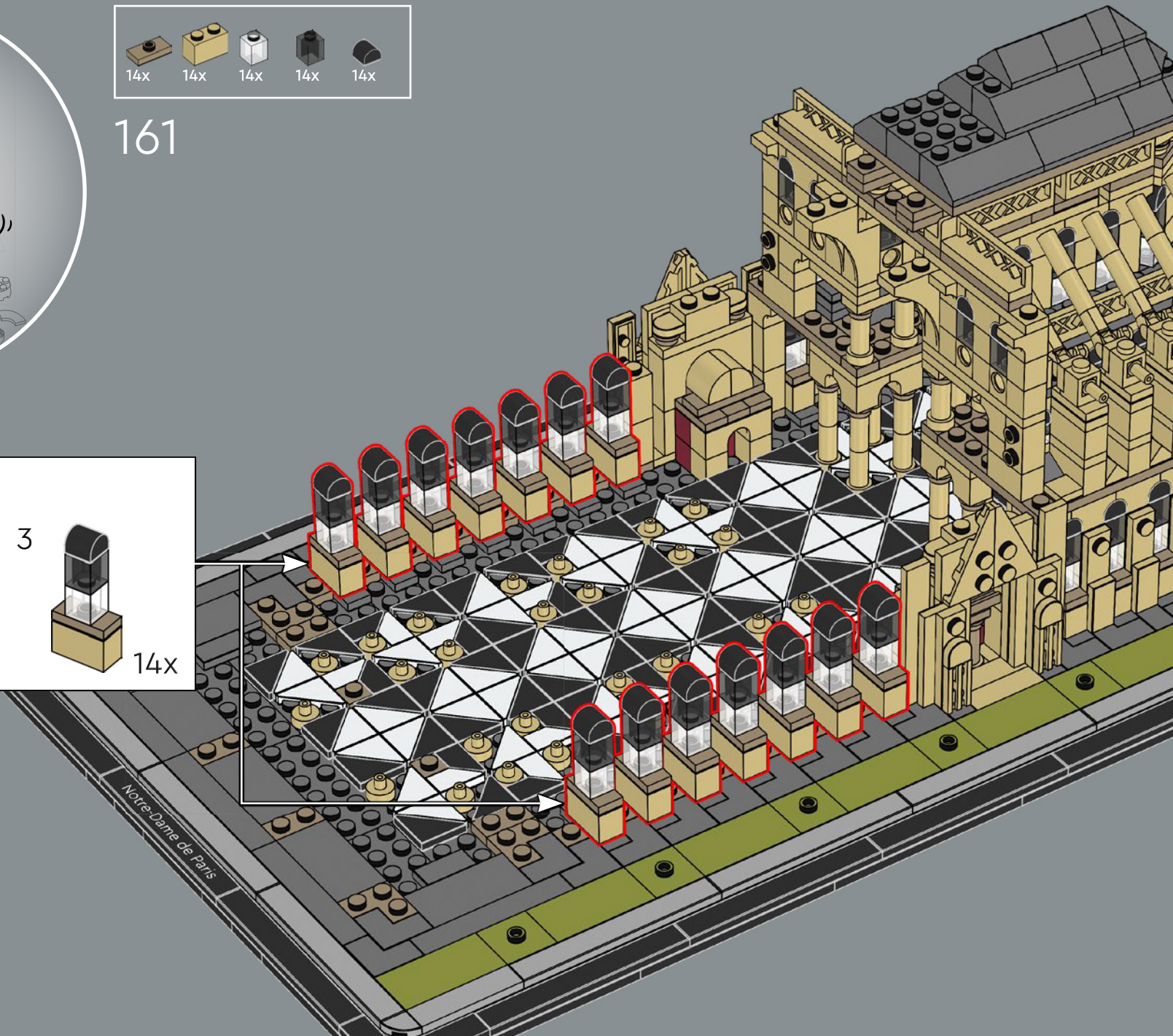
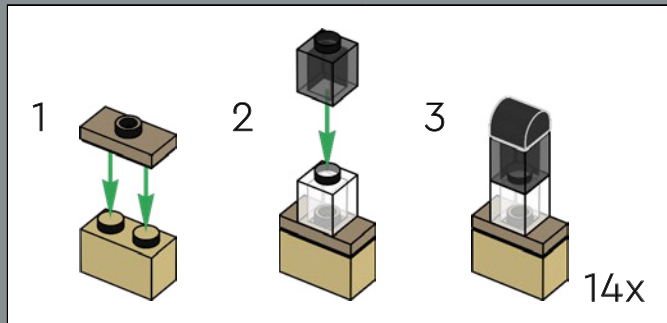

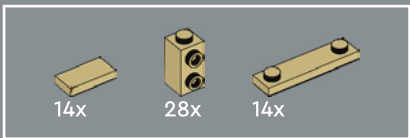

162

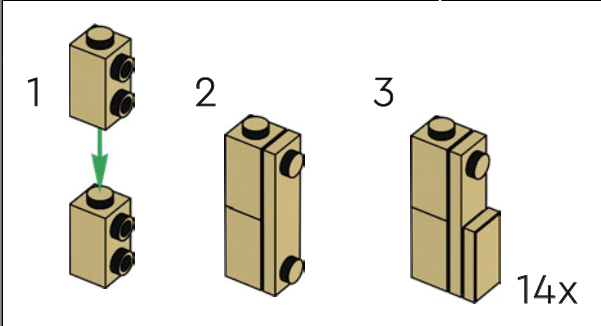
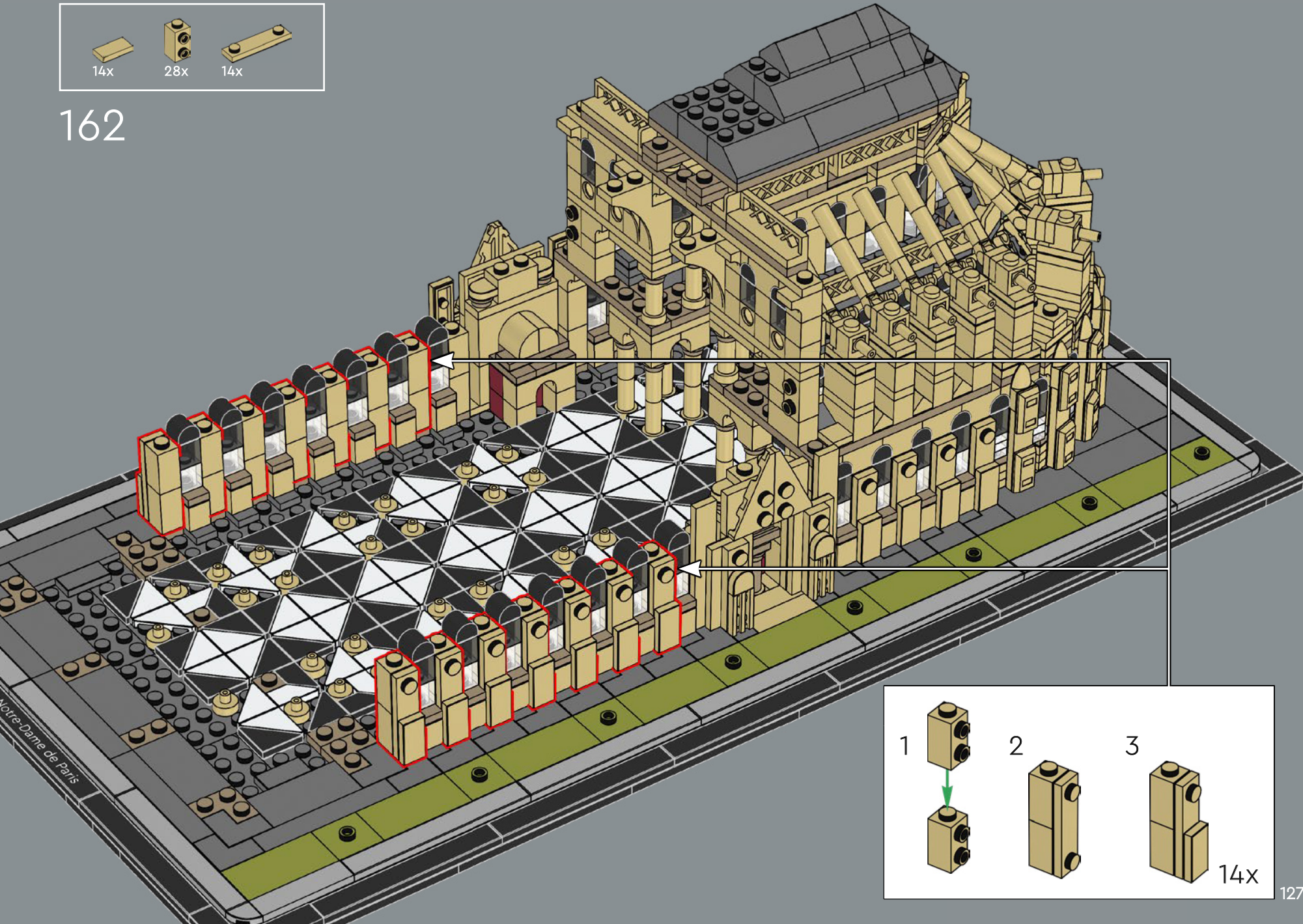



12x



4x

163





164

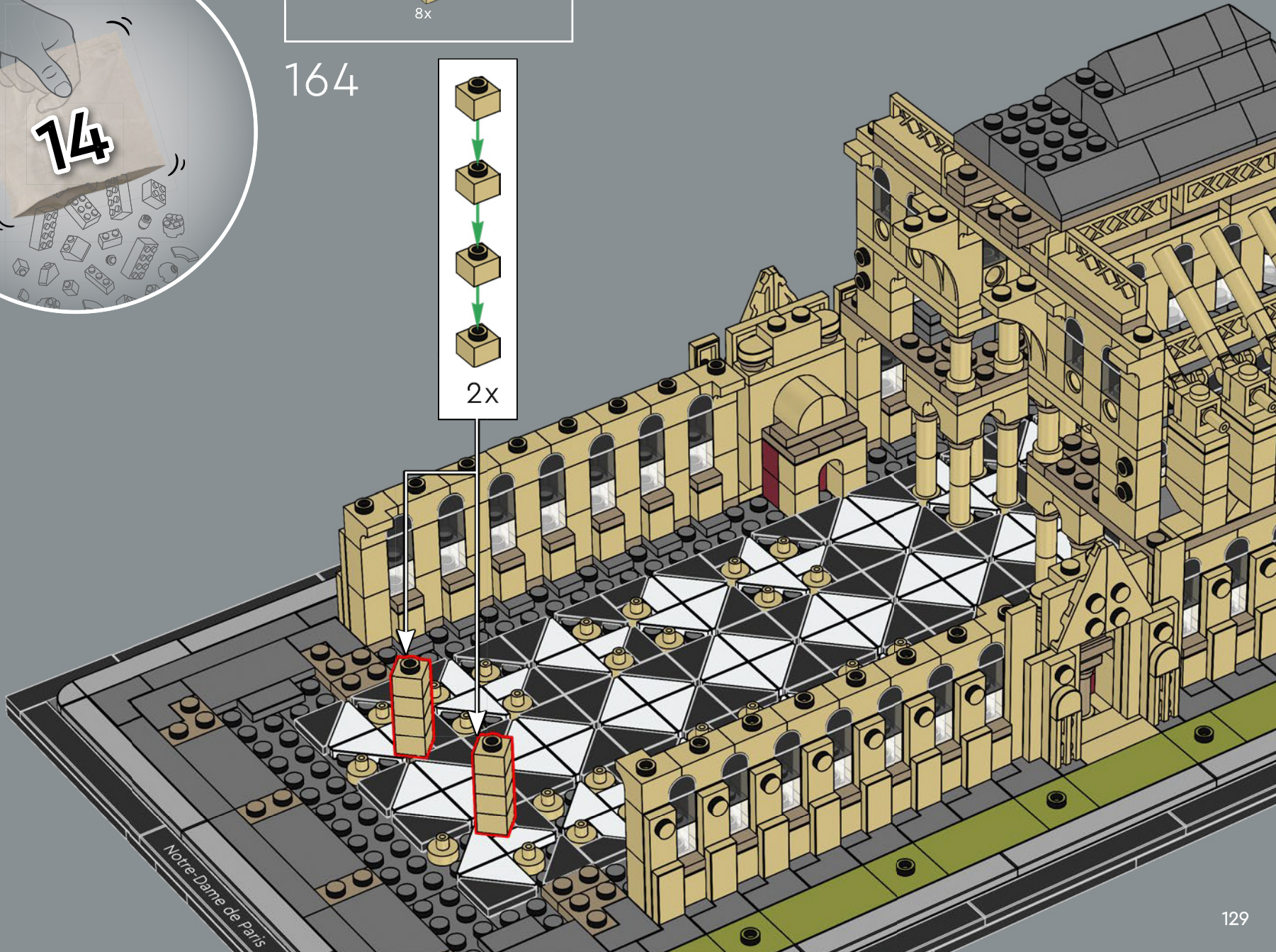
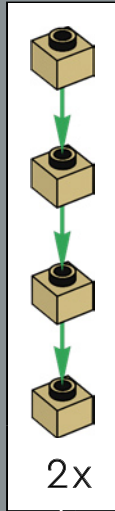



56x

165



28x

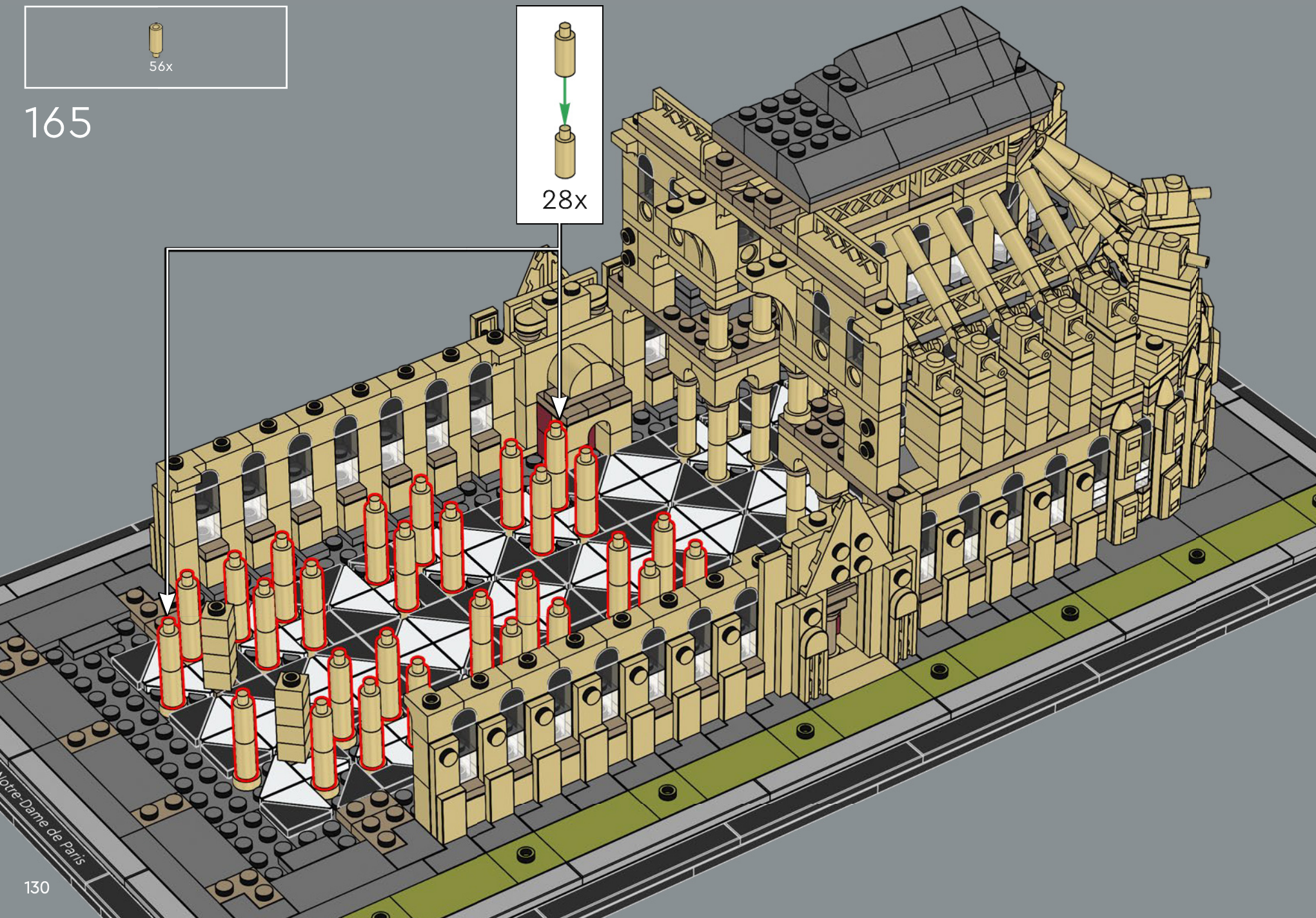

Notre-Dame de Paris

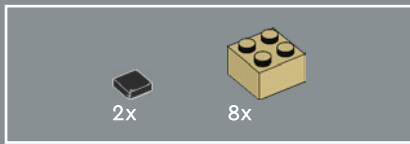

166

1208 年——中堂施工继续进行，西部塔楼的地基施工已完成。

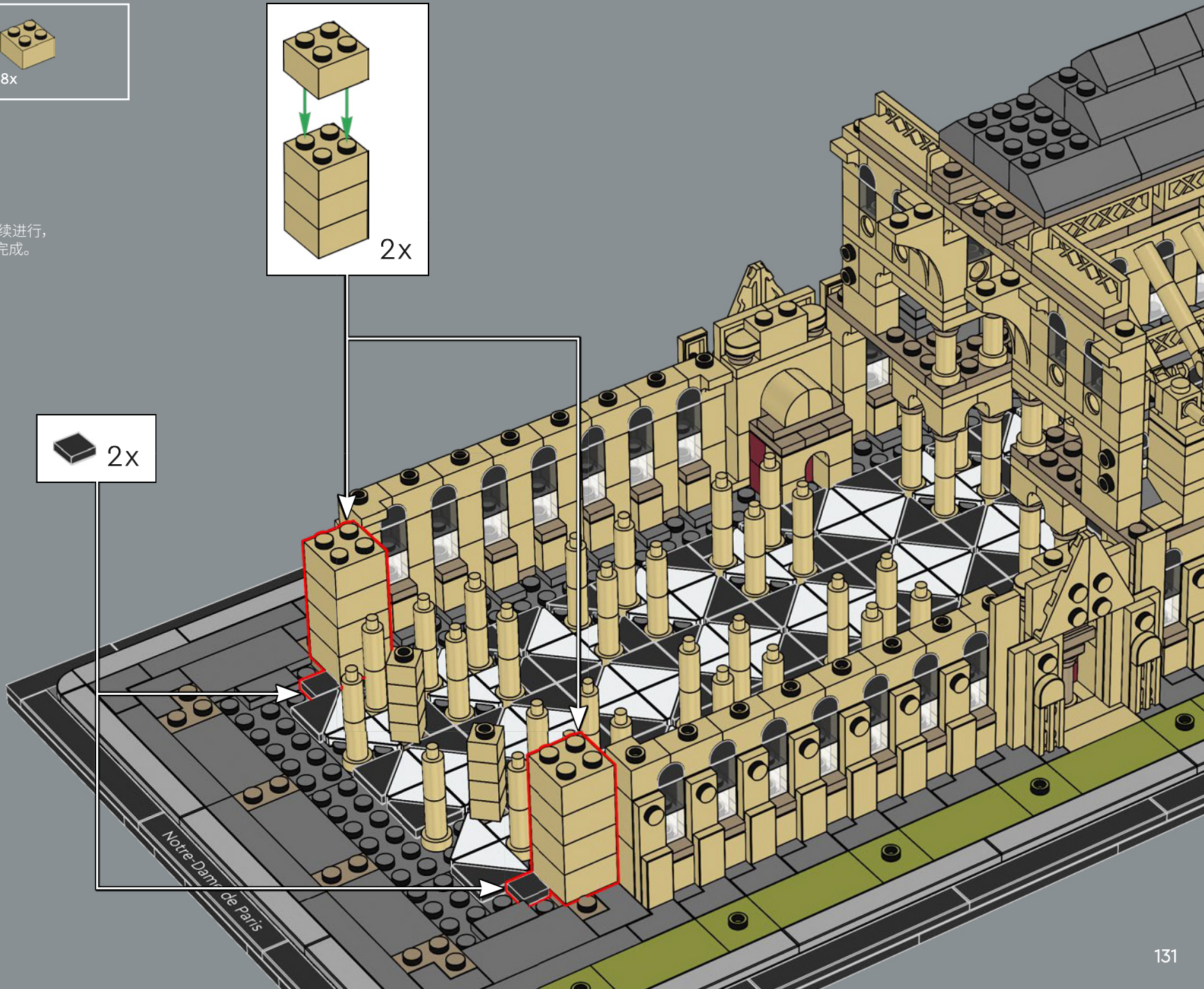
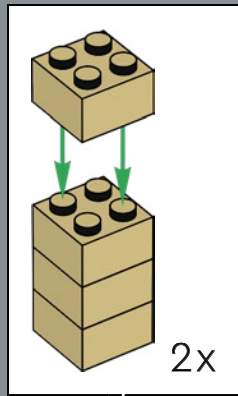

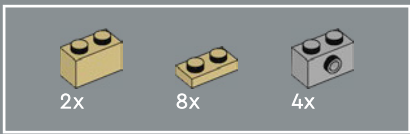

167

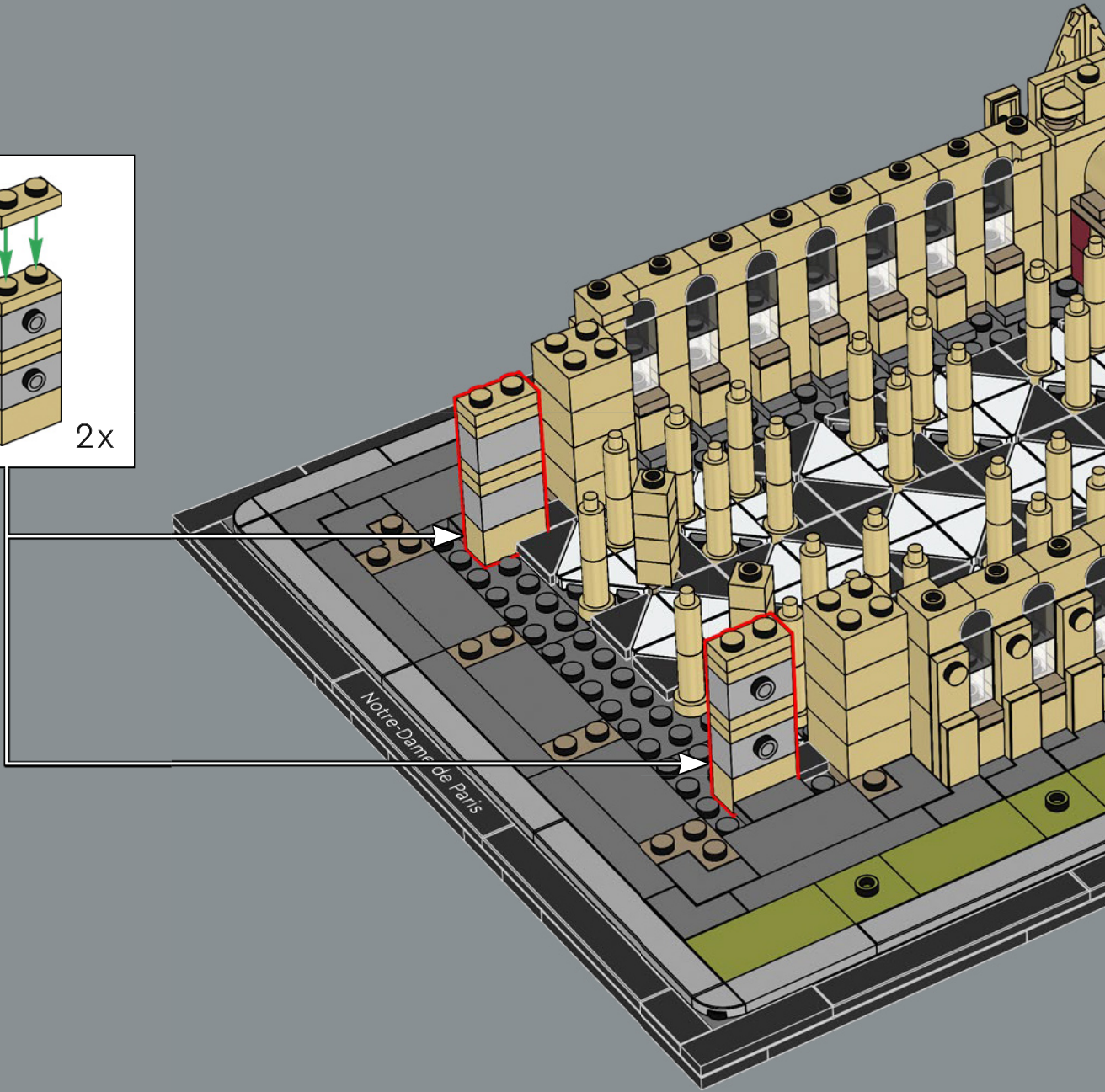
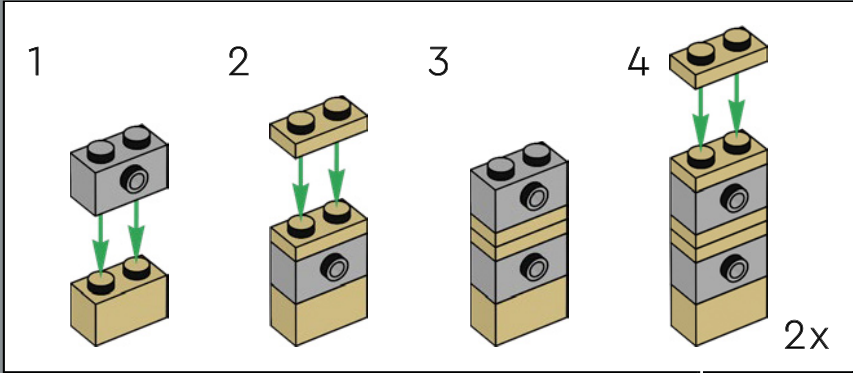

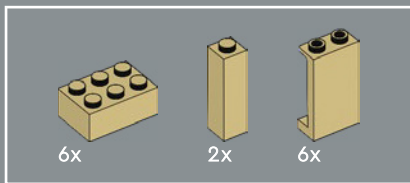

168

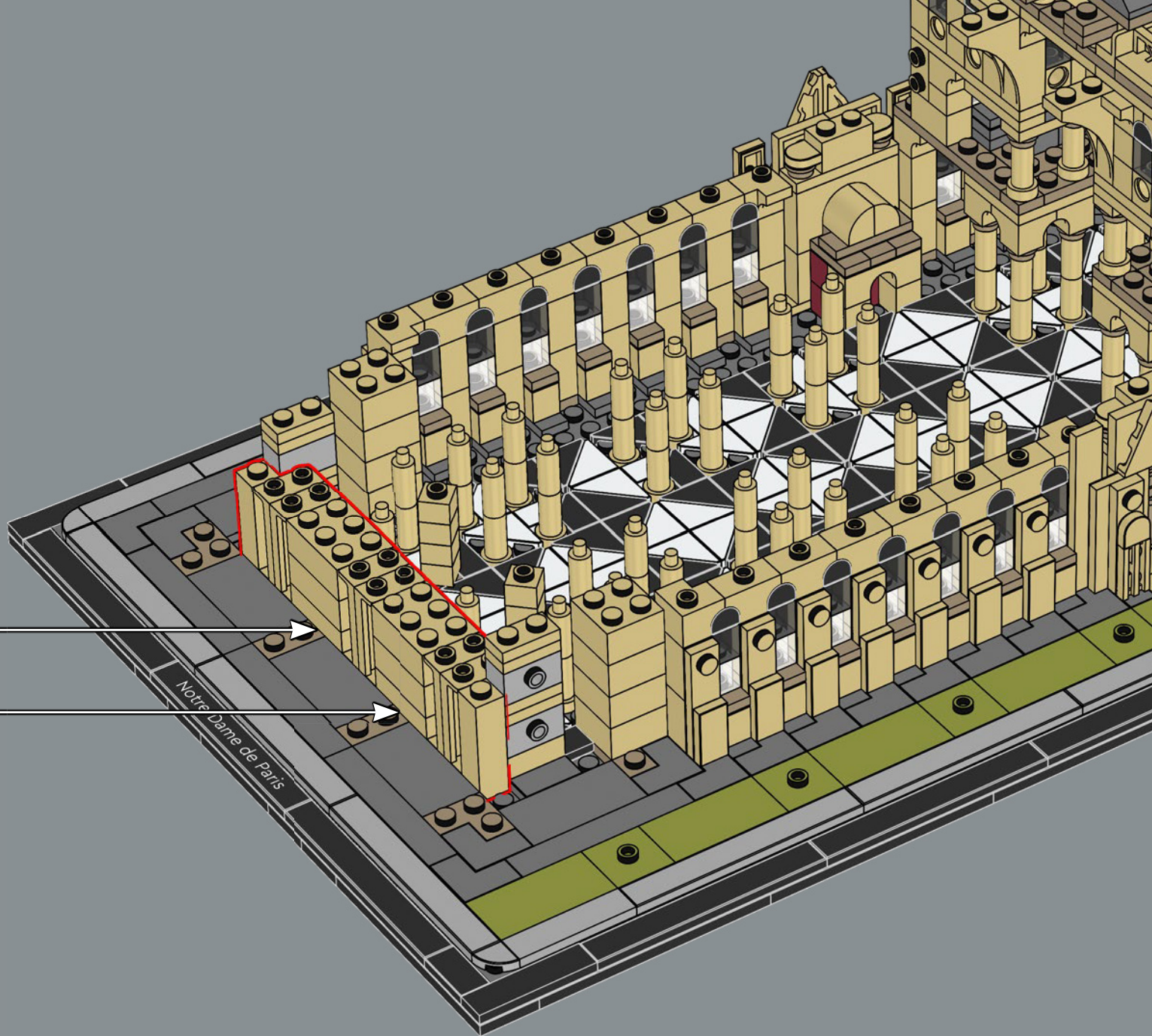
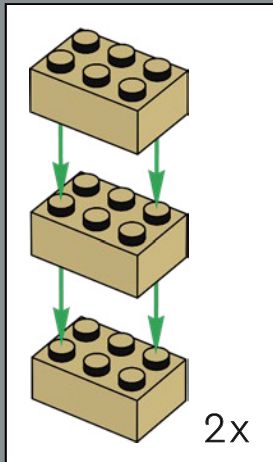

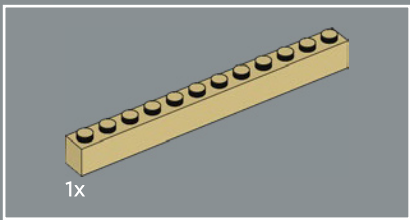

169

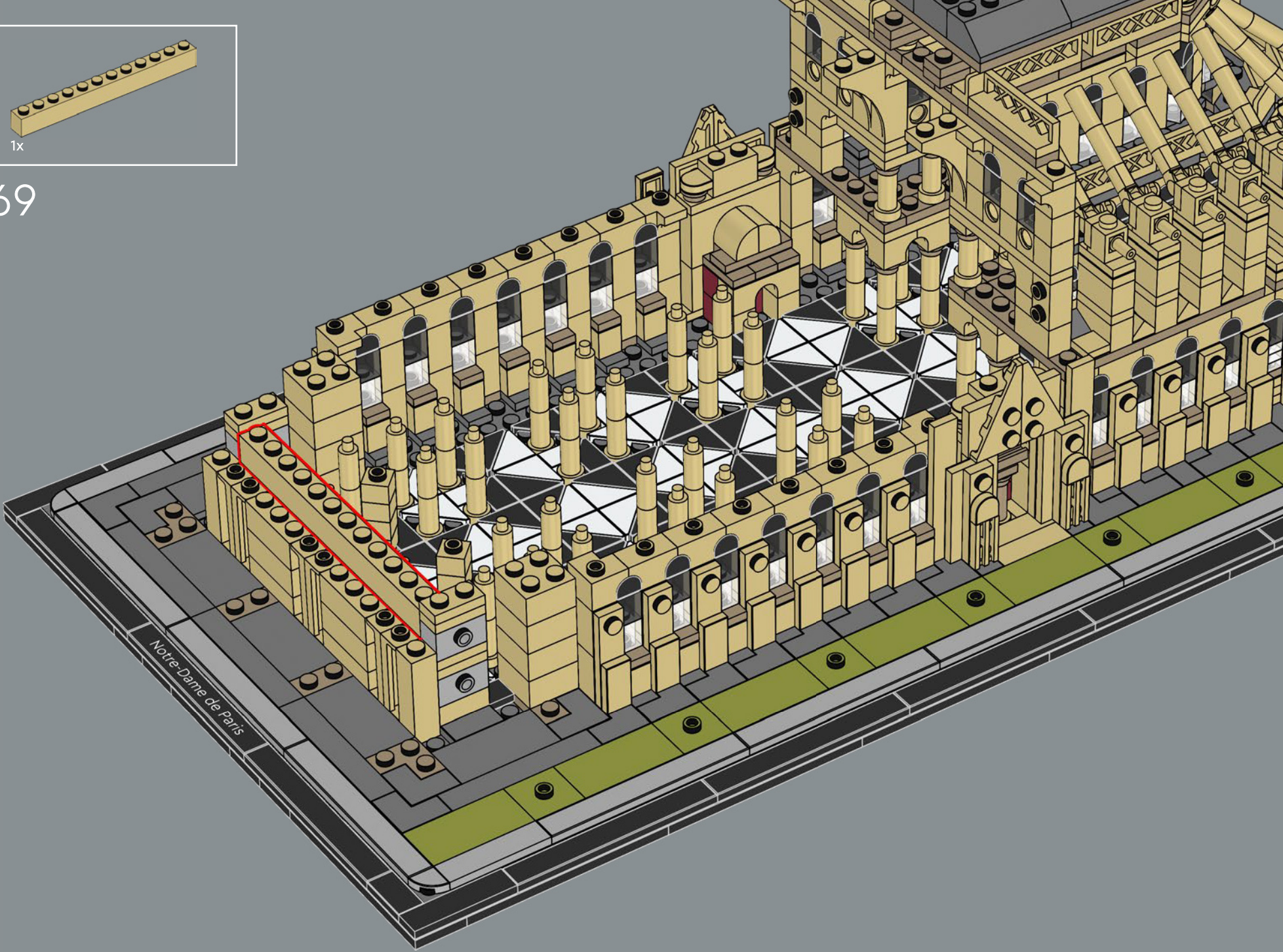



170

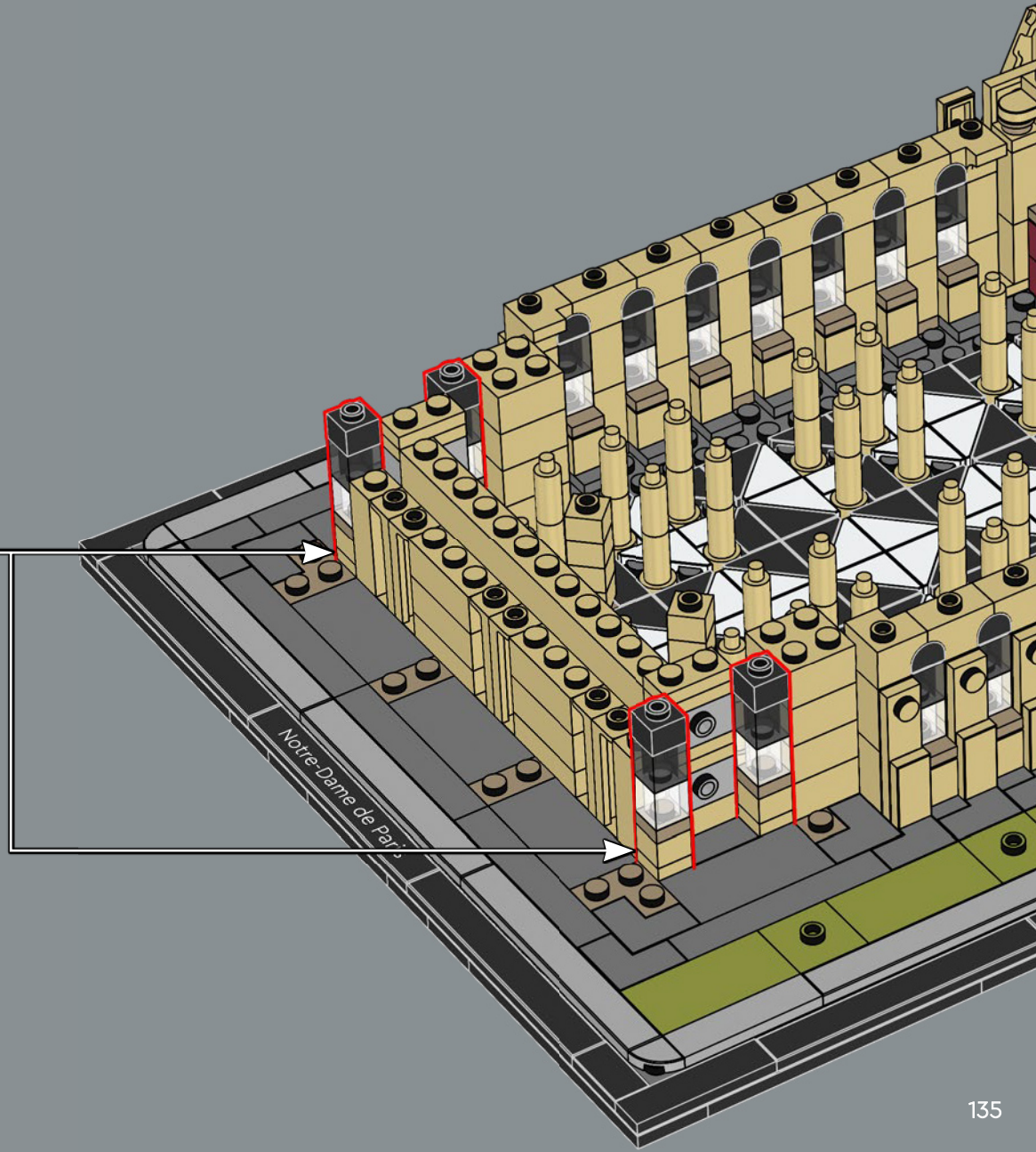
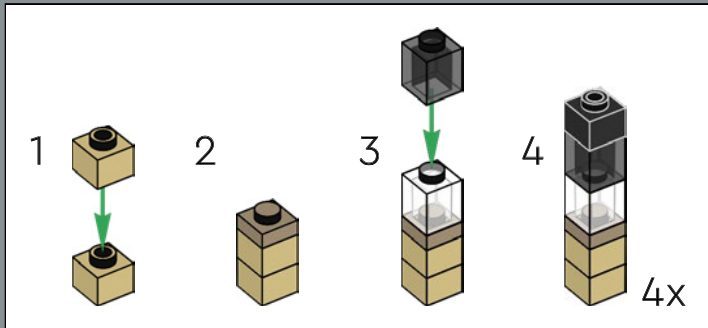

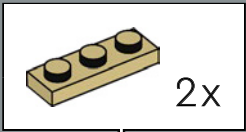
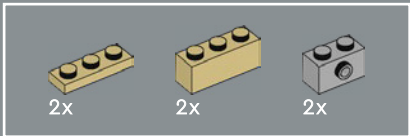

171

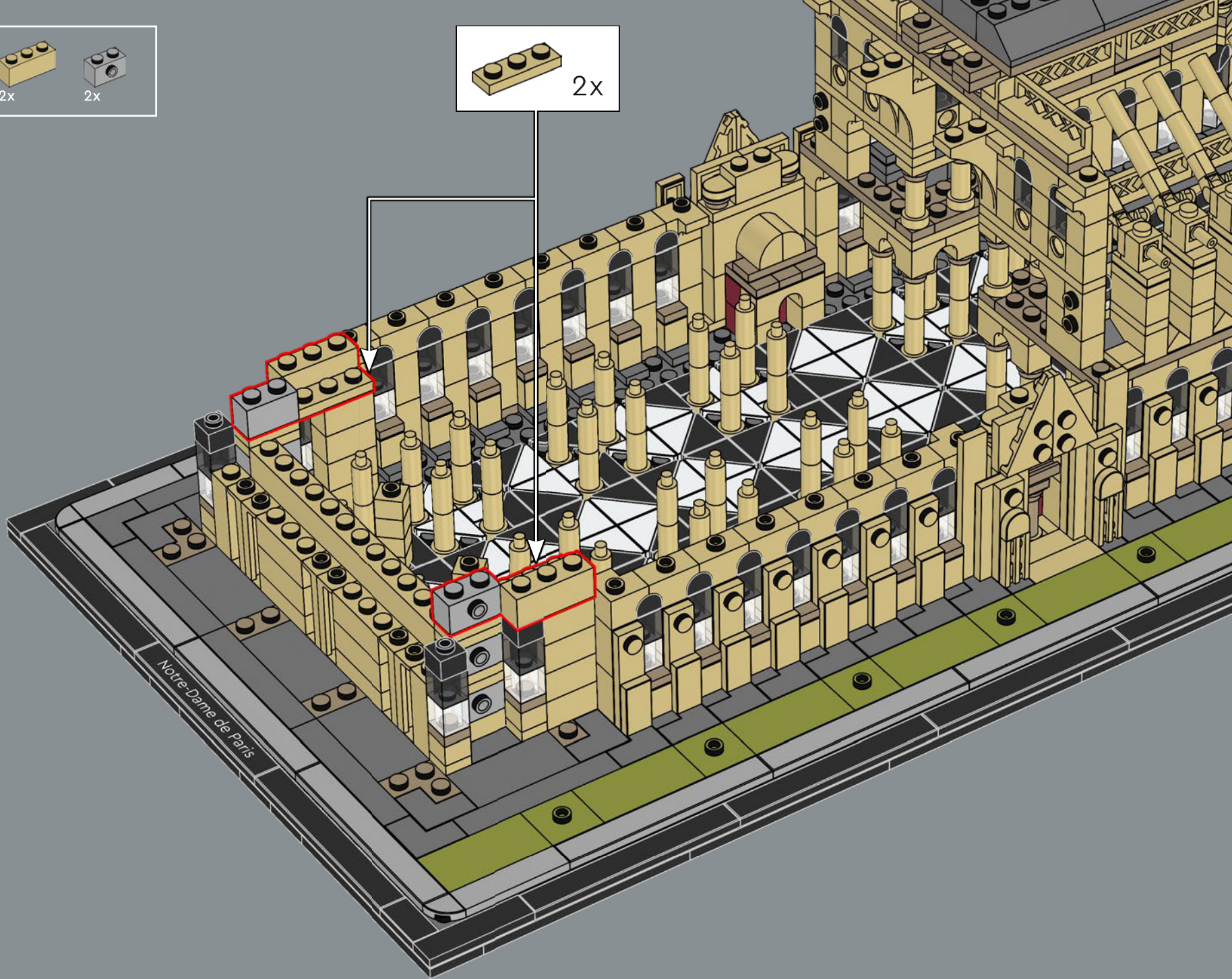

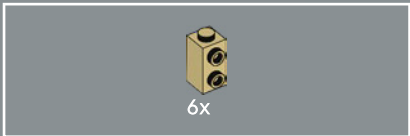

172

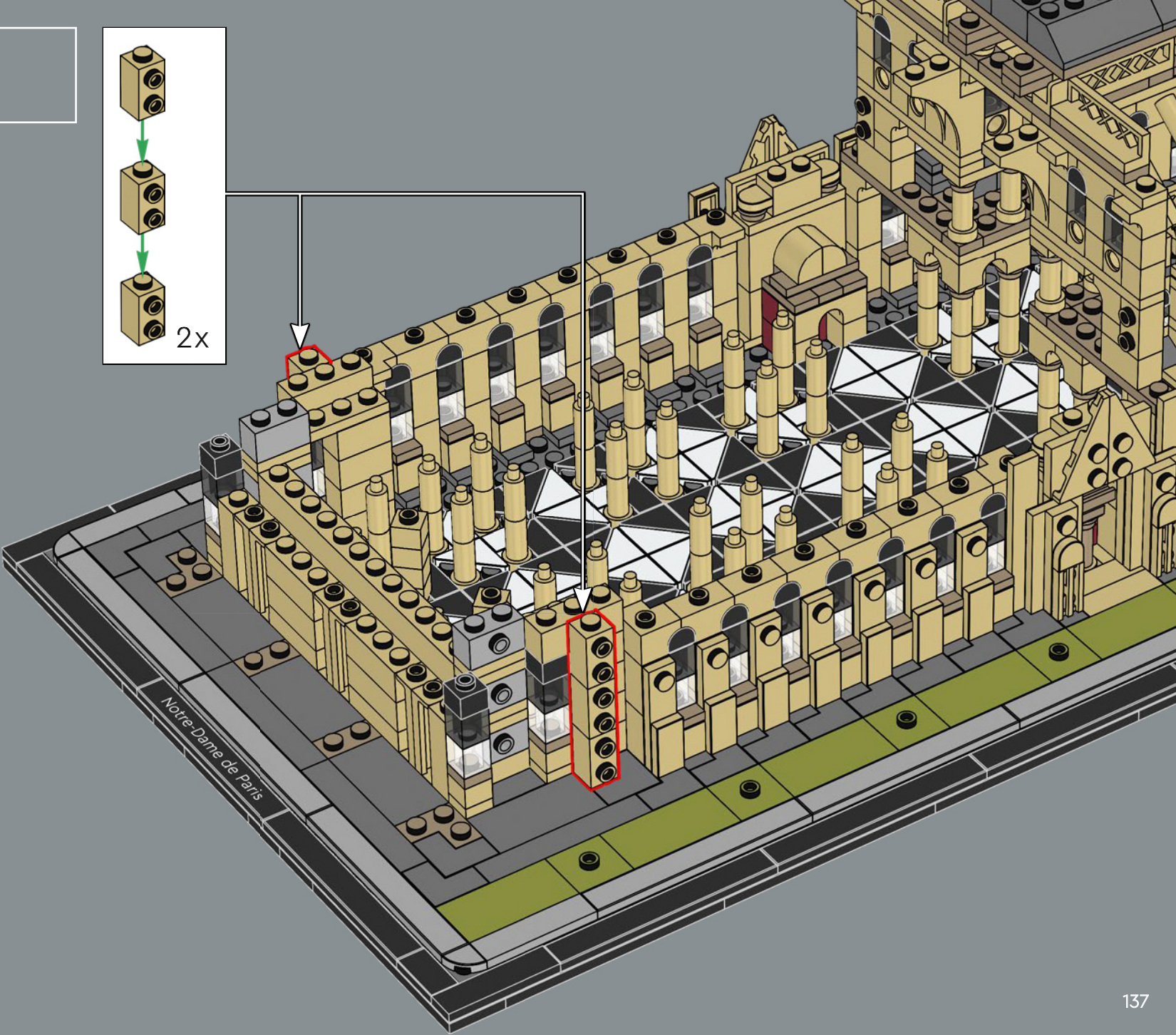
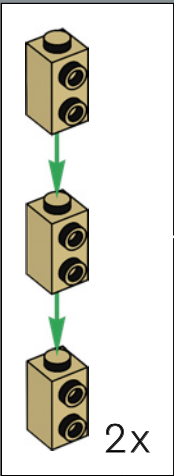



建造技术与特点

🌀 1208 年，耳堂建造完成，外墙上镶嵌着独特的巨型玫瑰花窗，均采用不同的尺寸和设计。原来的北面玫瑰花窗直径为 13.5 米 (44.2 英尺)，创下了当时的记录。巴黎圣母院的每个建筑特色都具有同一个目的：同时具备装饰性和实用性。三个乐高®玫瑰花窗组件是对原始建筑结构的抽象处理——它们的大小和设计完全相同，你可以在模型中互换使用。到 1220 年，除了塔楼的上部之外，巴黎圣母院的主体已经完工。



通过疏导雨水，独具特色的滴水兽还可以保护巴黎圣母院免受雨水的过度冲蚀。从模型中也可以看到此功能的复刻版。



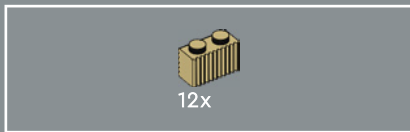

173

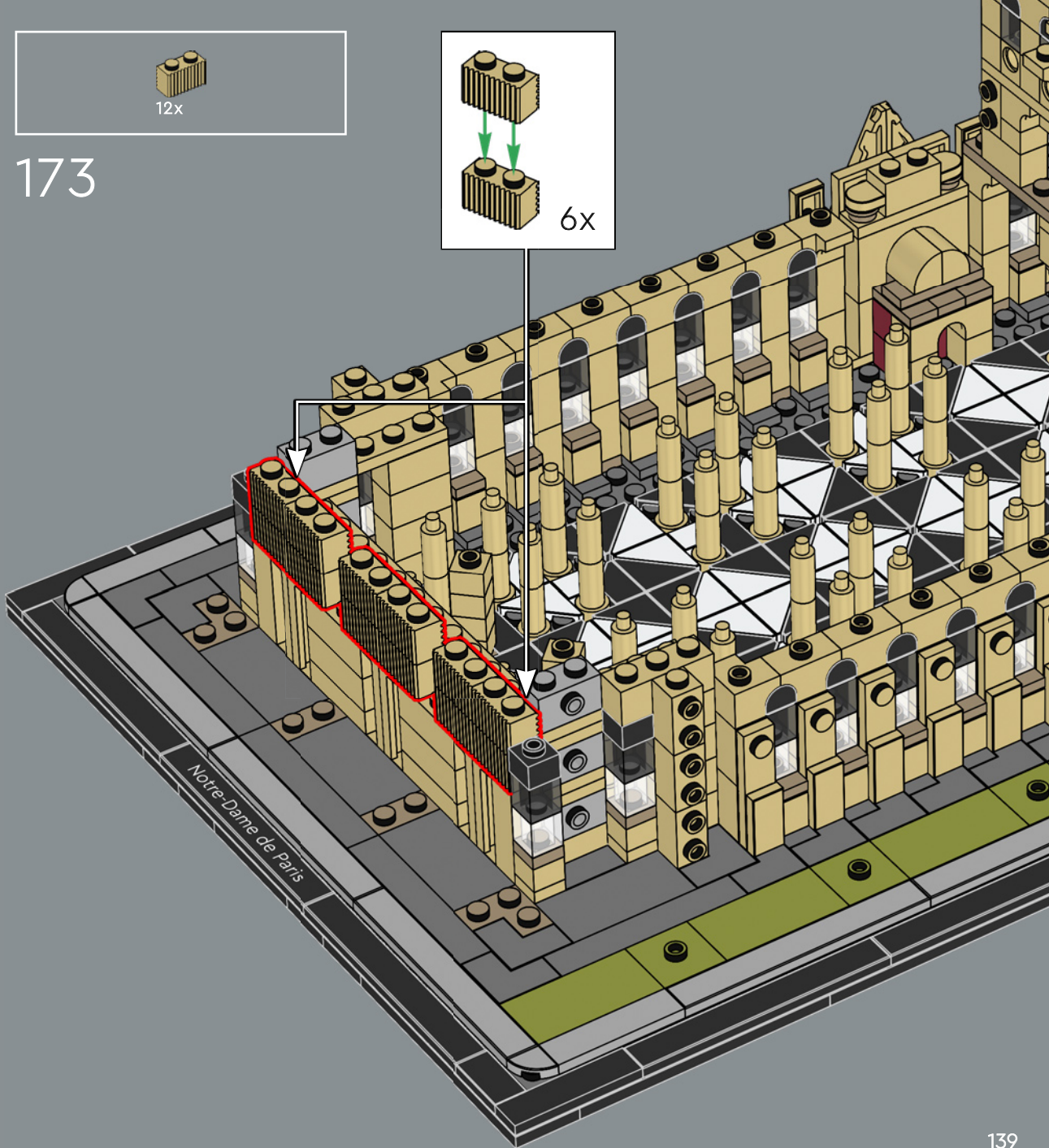
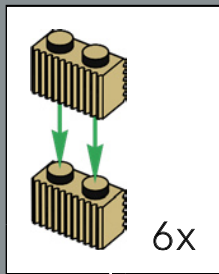

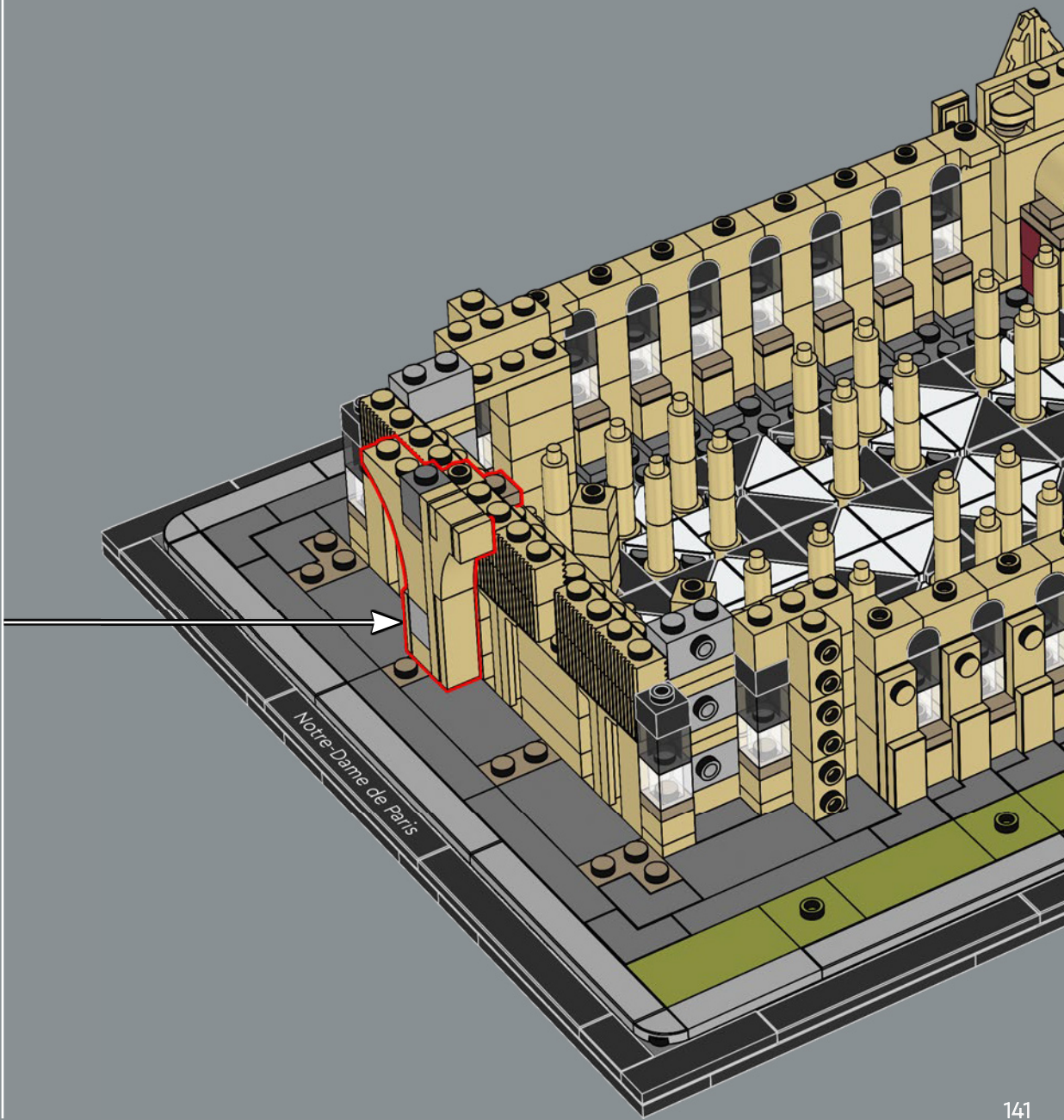
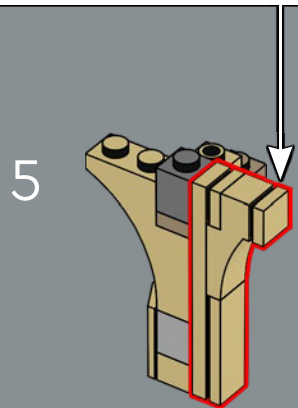
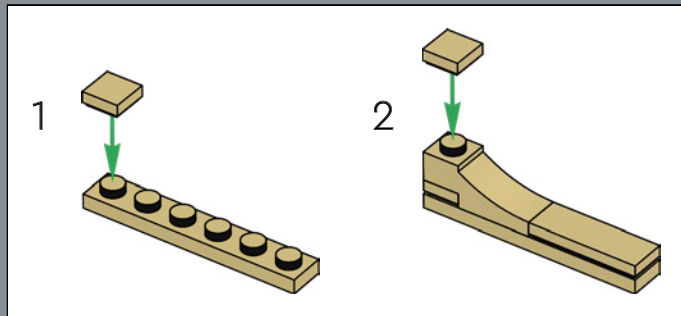

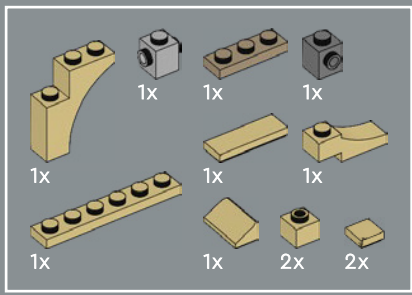

175

1

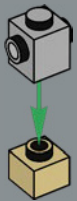

2



3

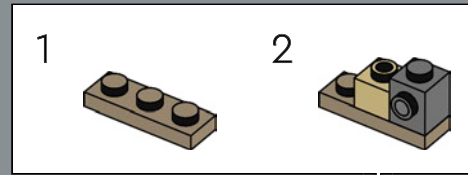
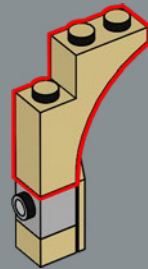

4

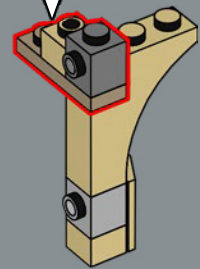

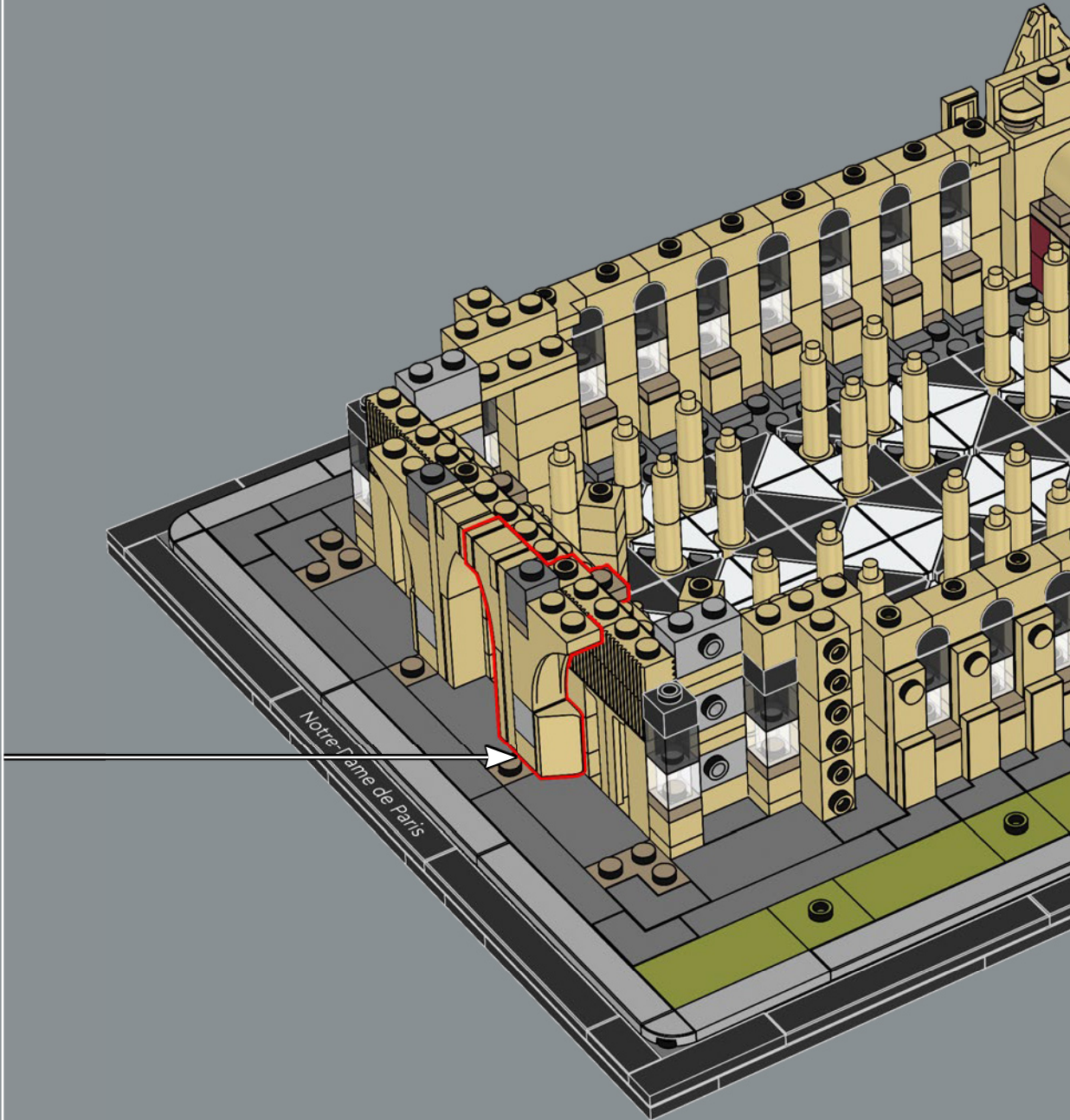
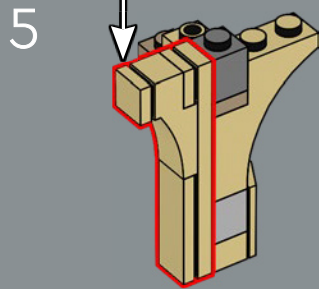
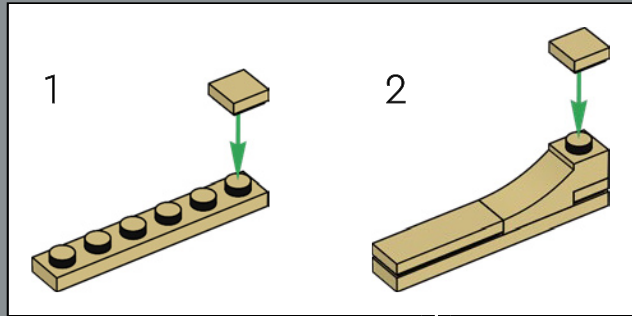

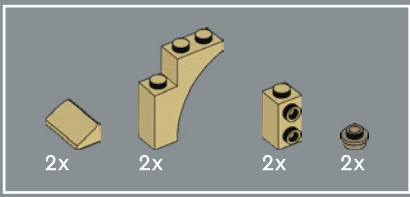

176

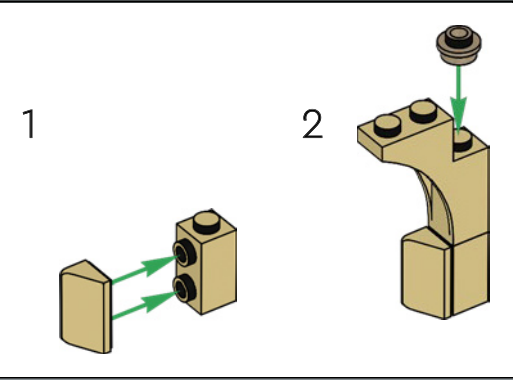
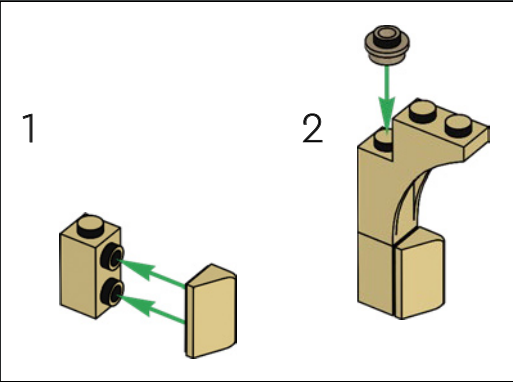

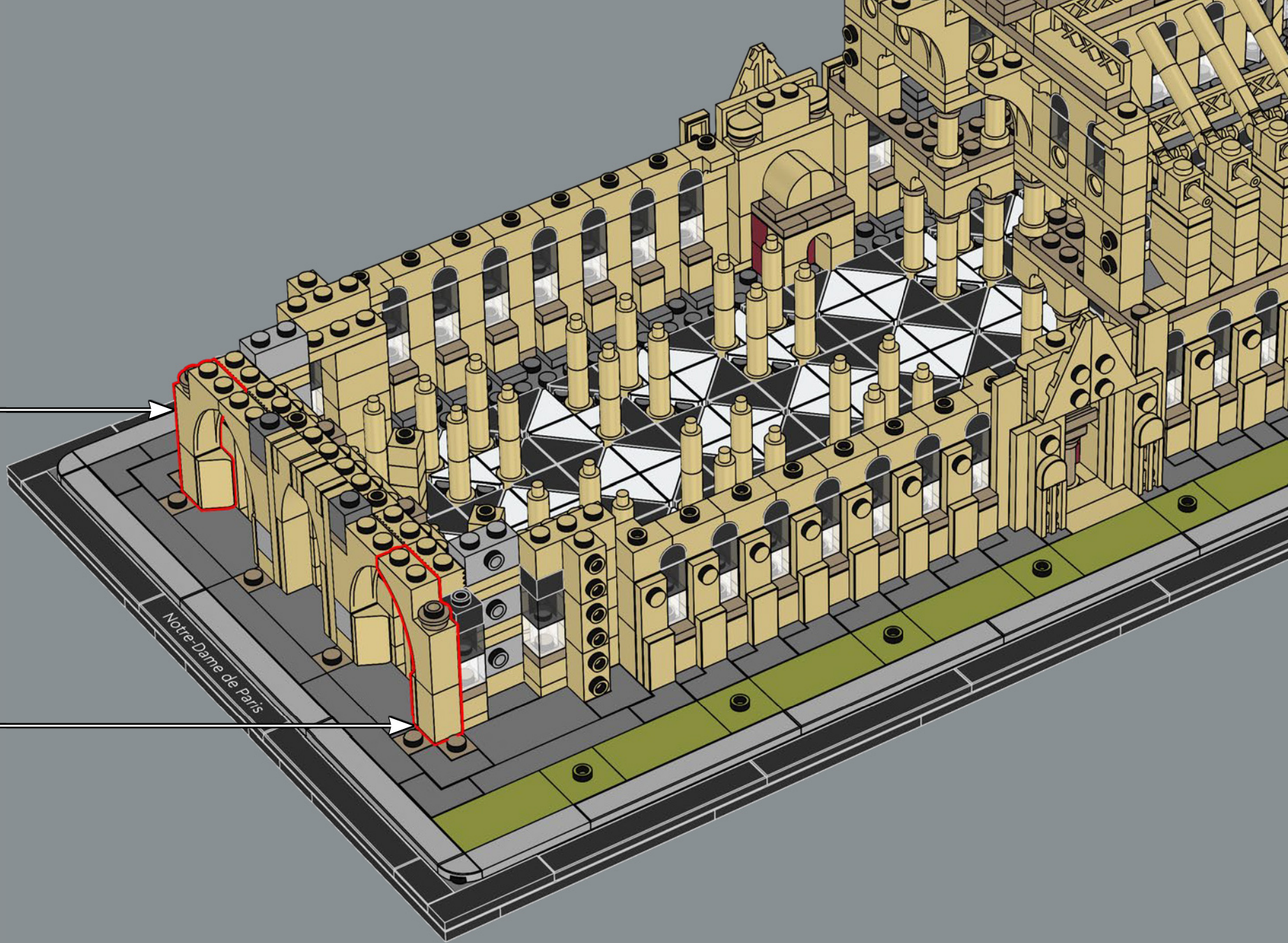

Notre-Dame de Paris

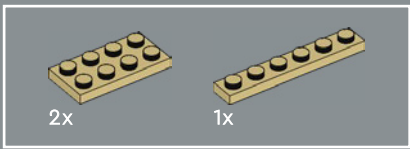

177



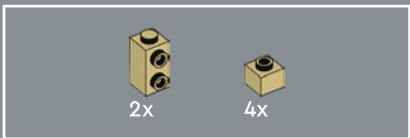

178

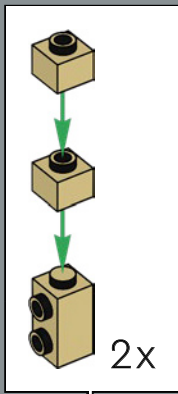

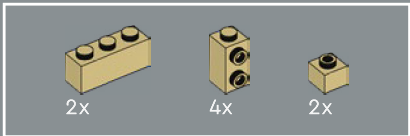

179

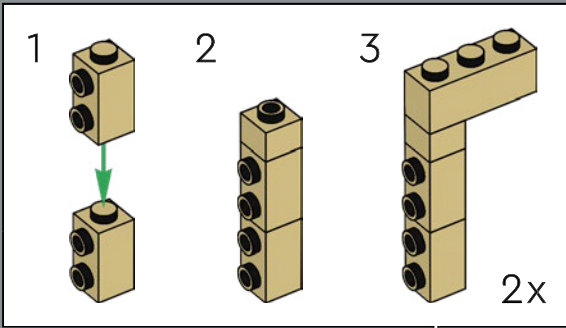

Notre-Dame de Paris

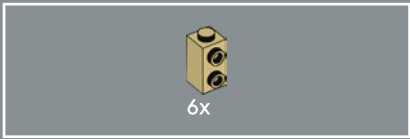

180

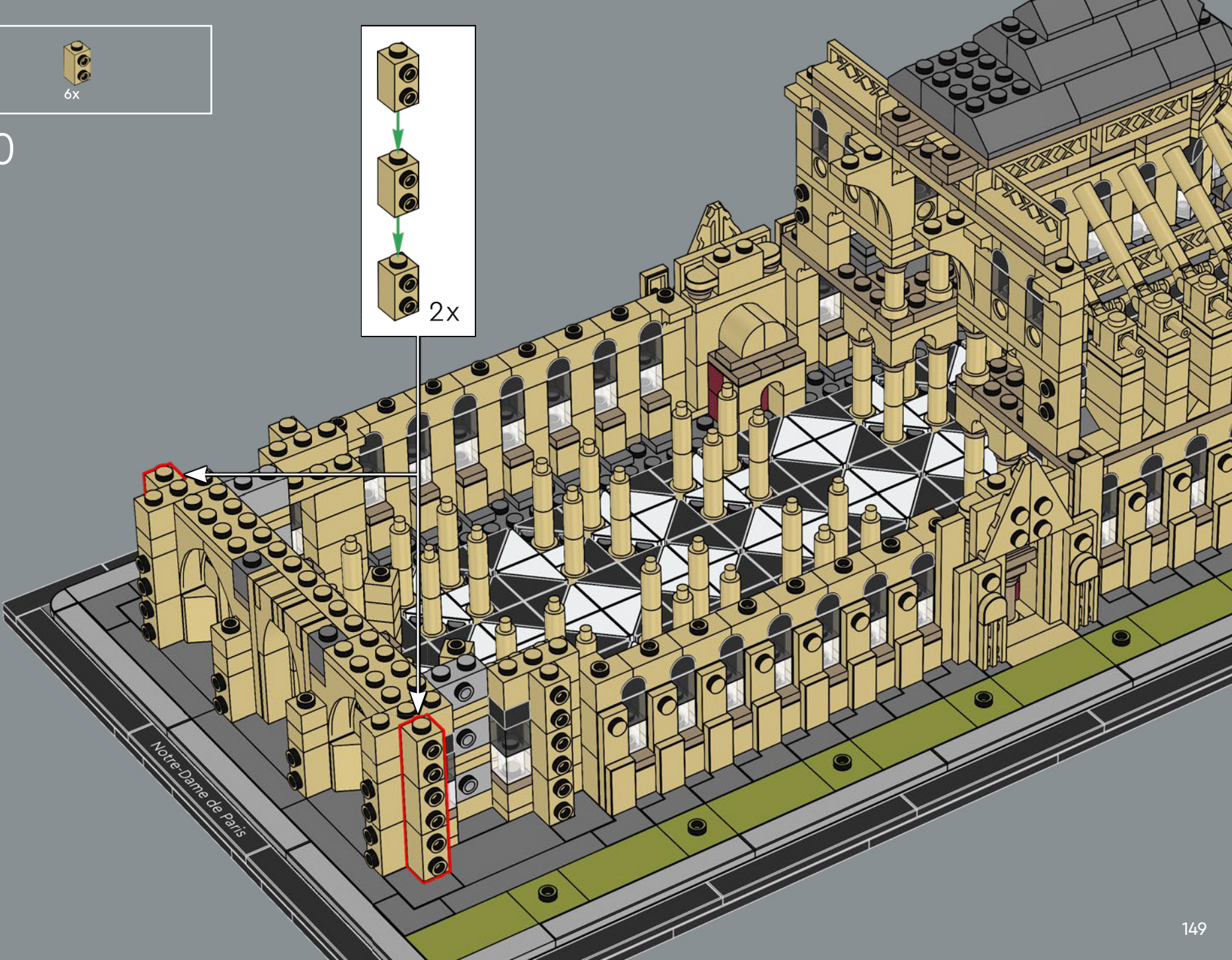
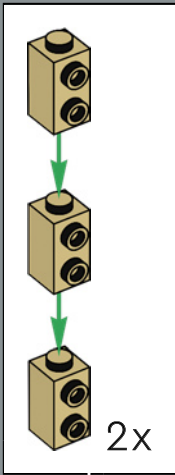

Notre-Dame de Paris

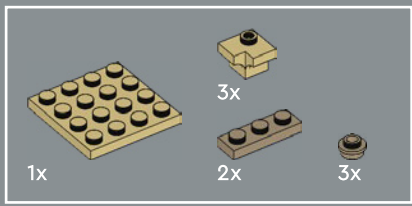

181

1

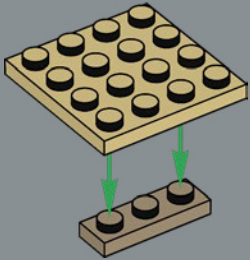

2

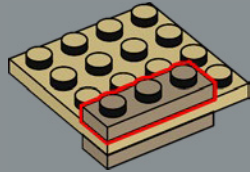

3

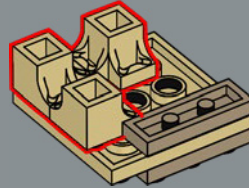

4

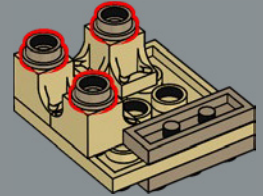



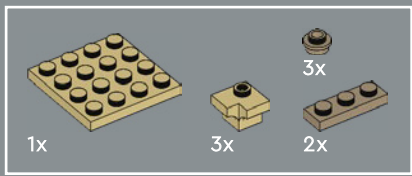

182

1

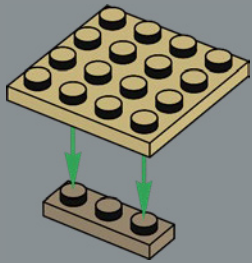

2

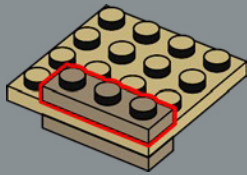

3

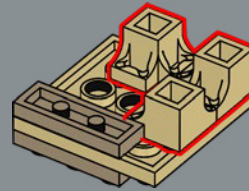

4

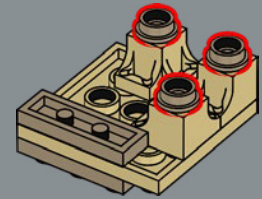



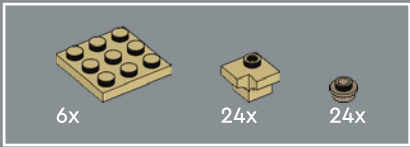

183

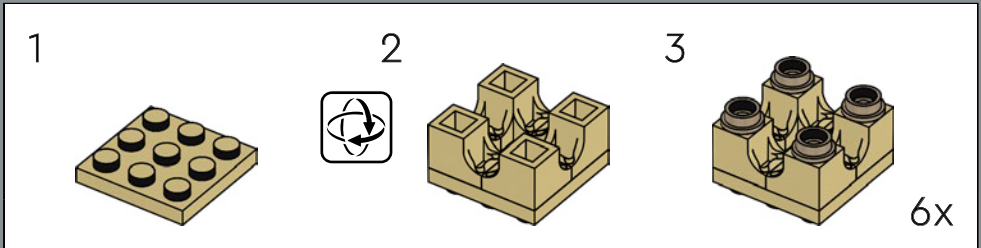

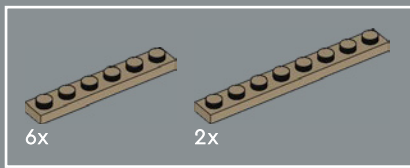

184

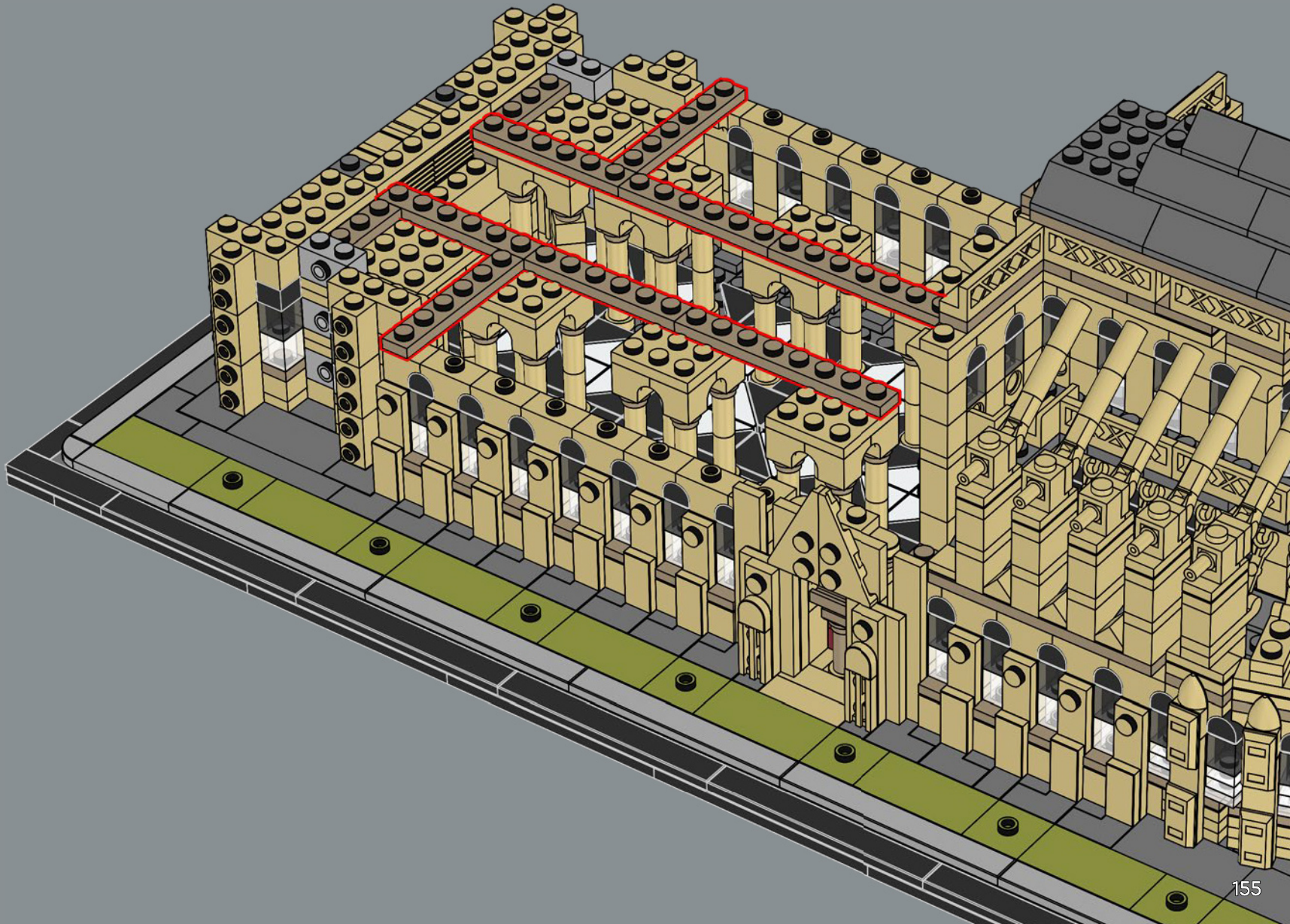

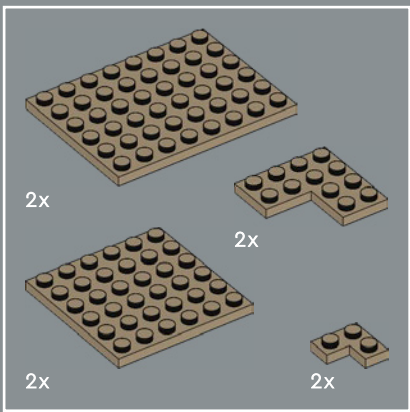

185

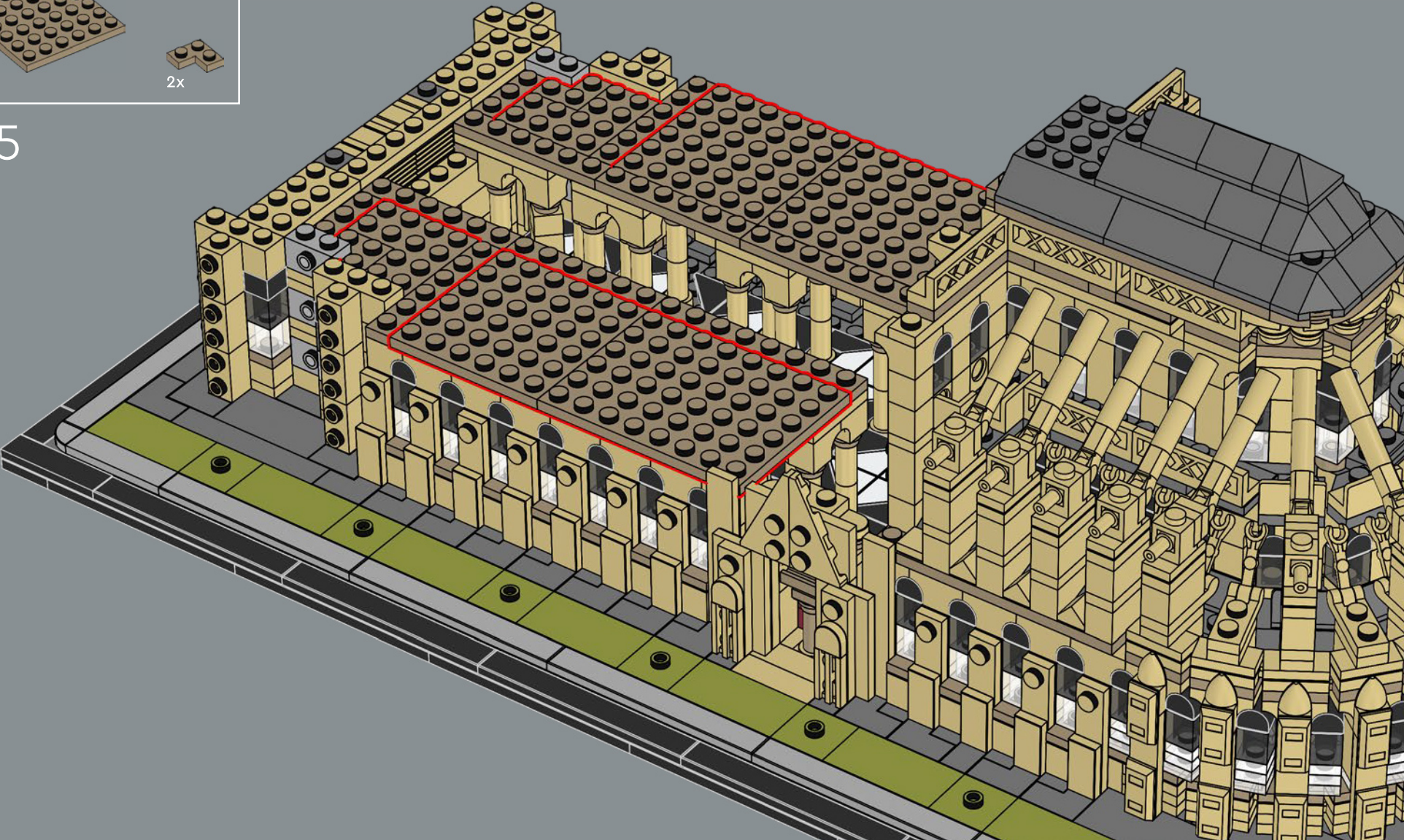

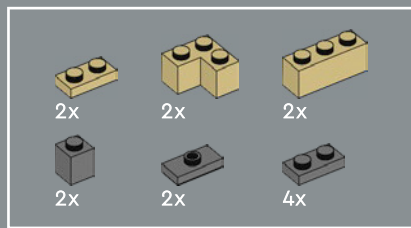

187

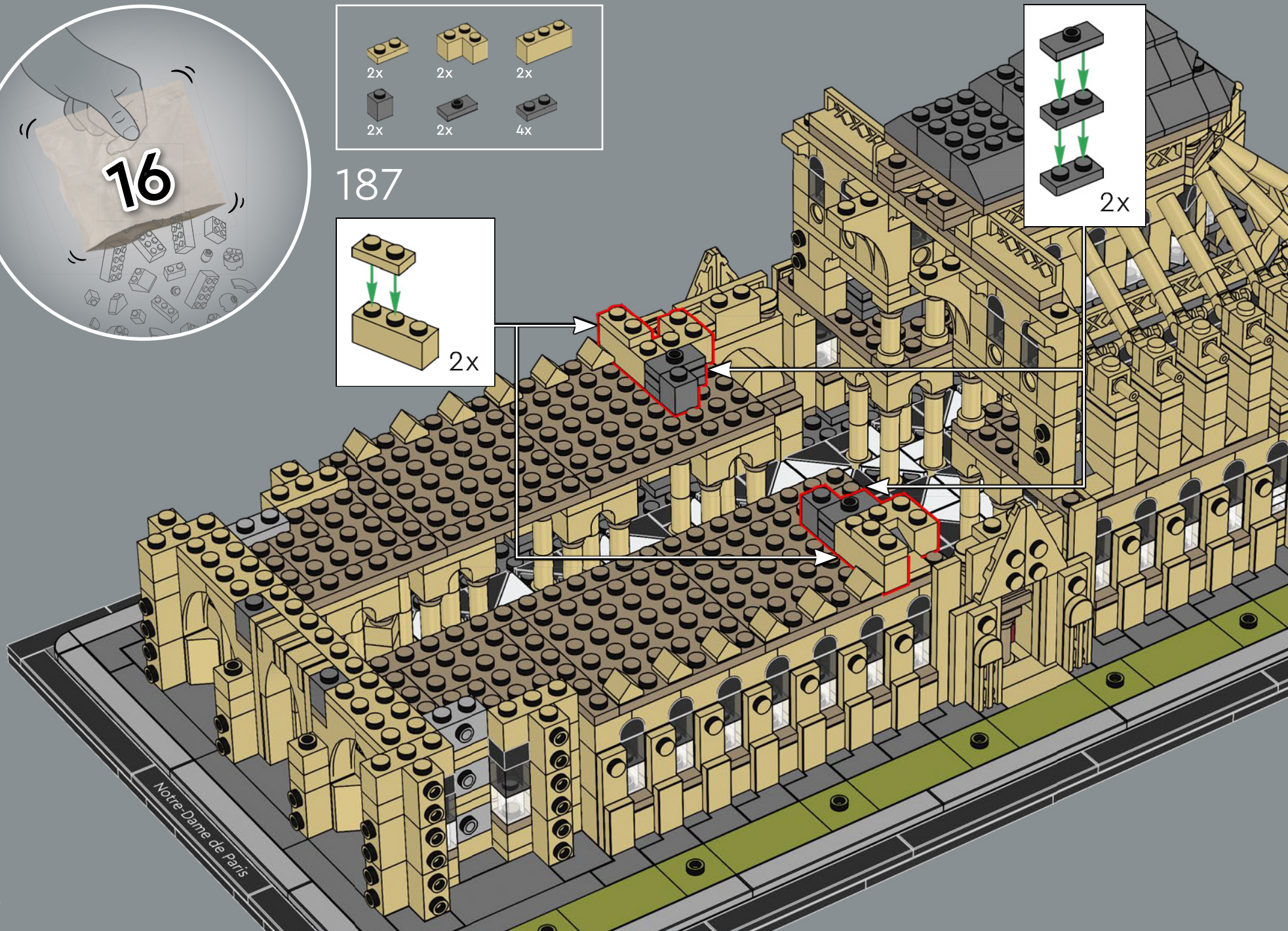
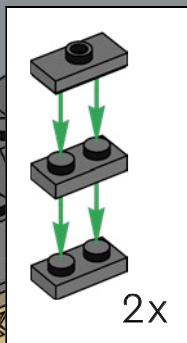
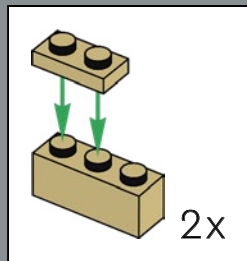

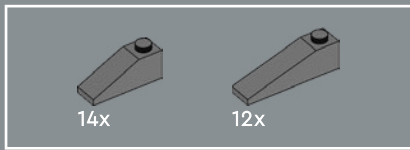

188

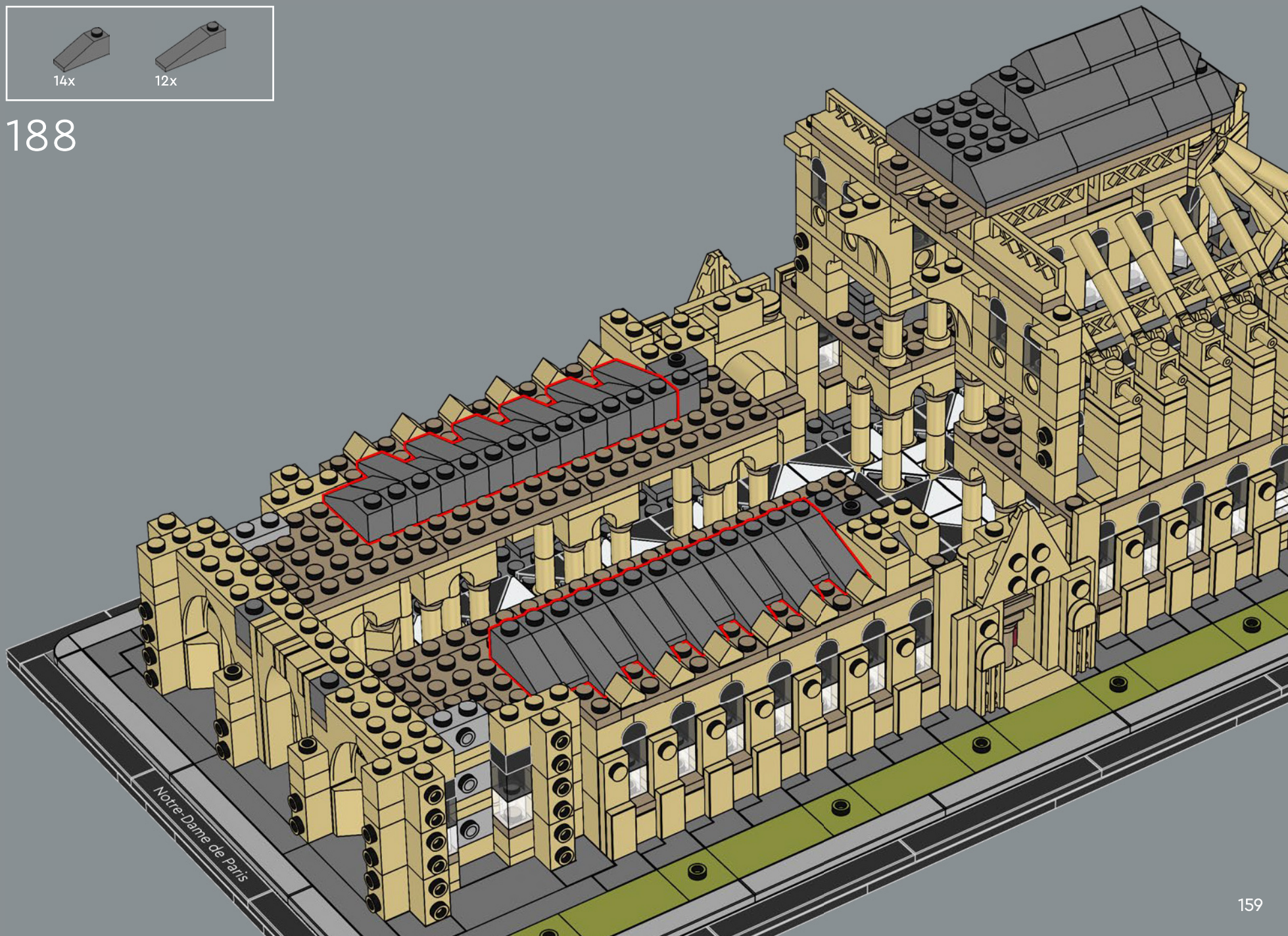

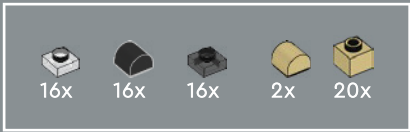

189

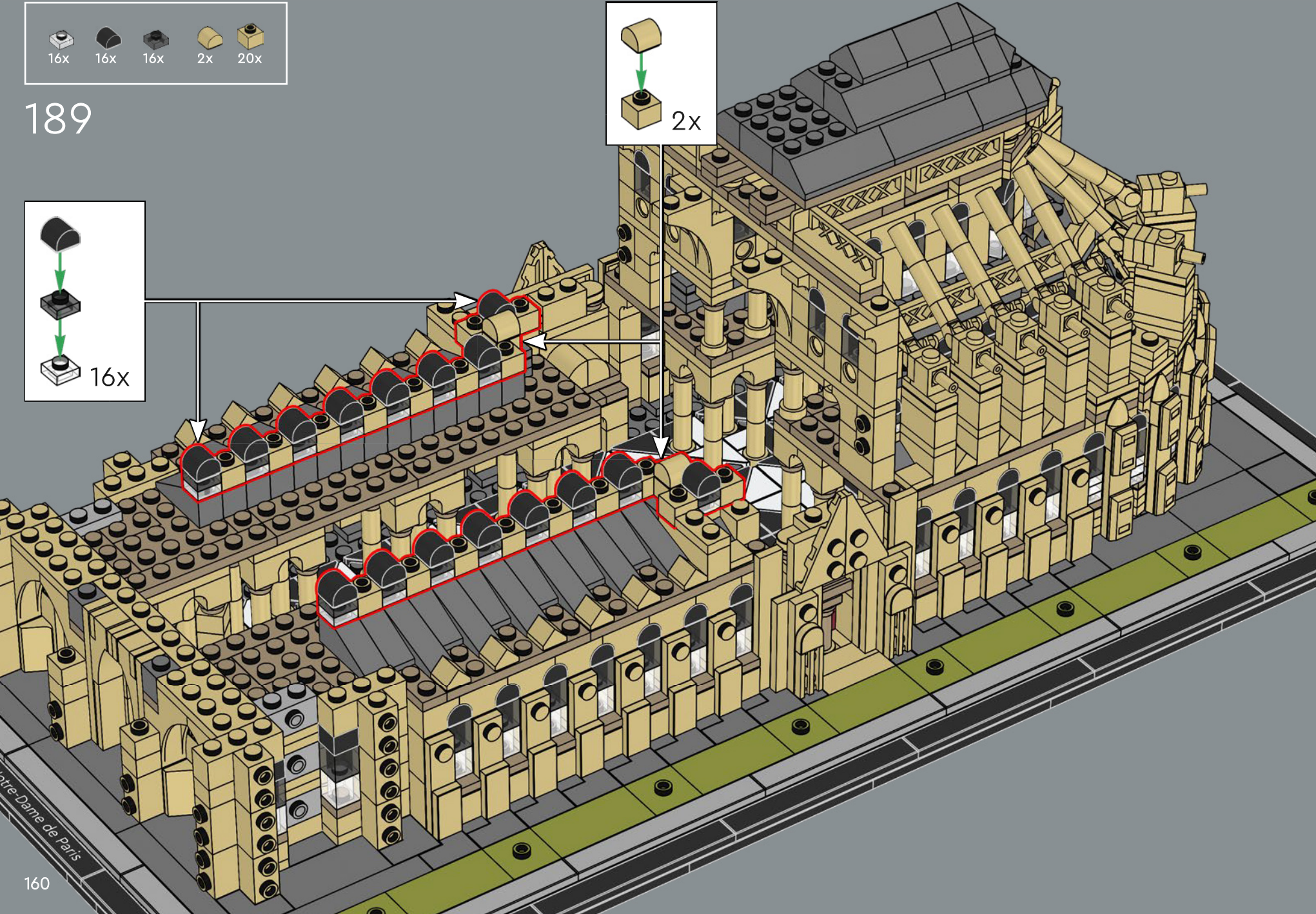
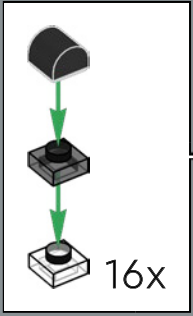
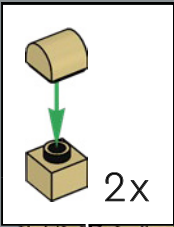

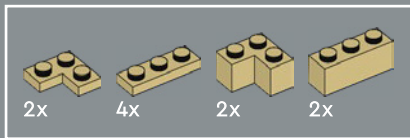

190

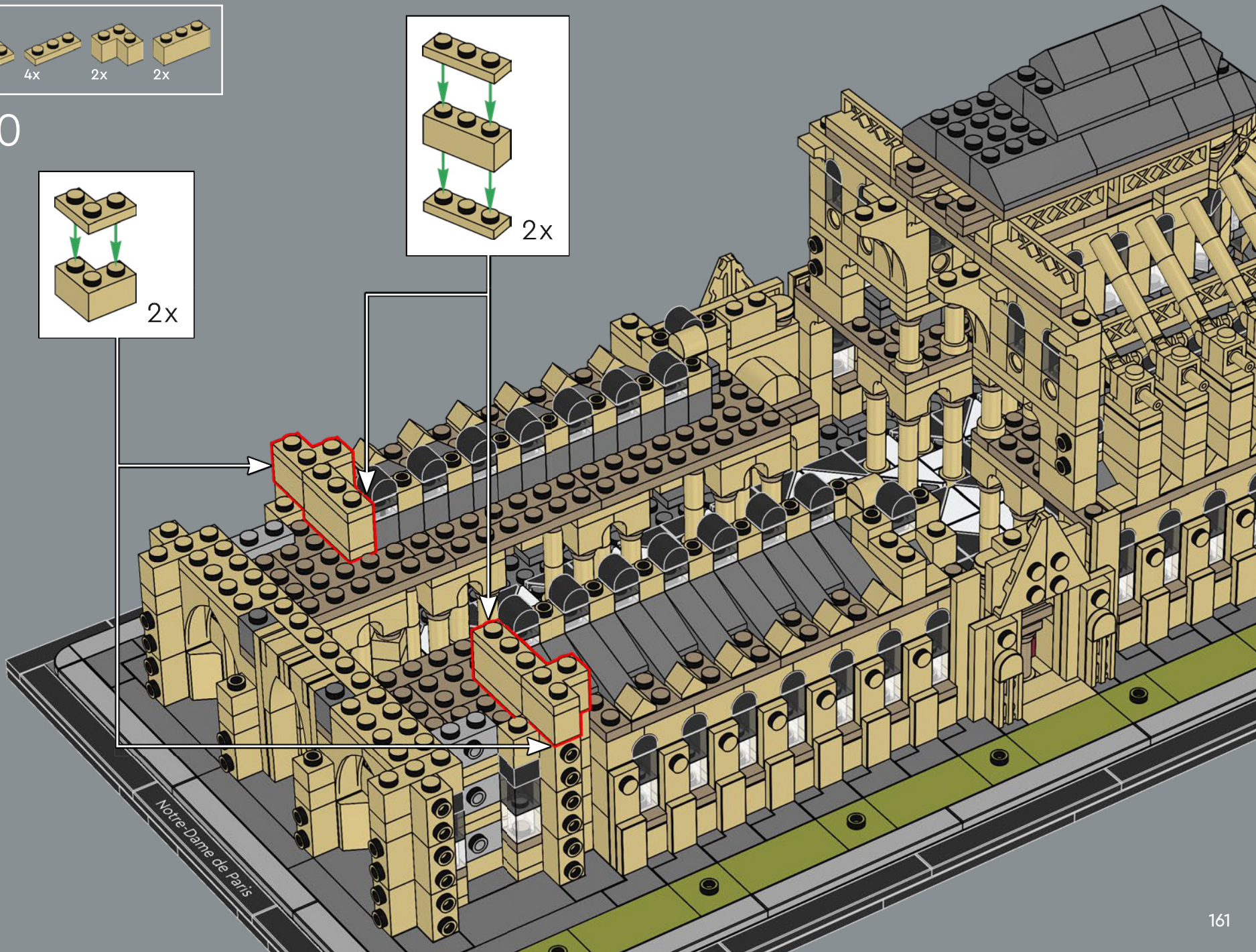
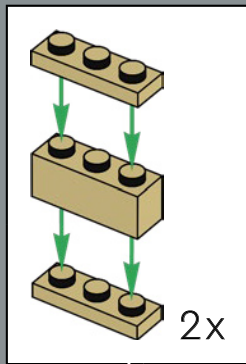
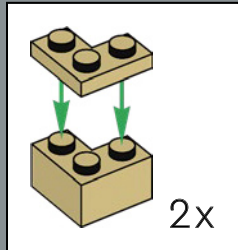



6x

191

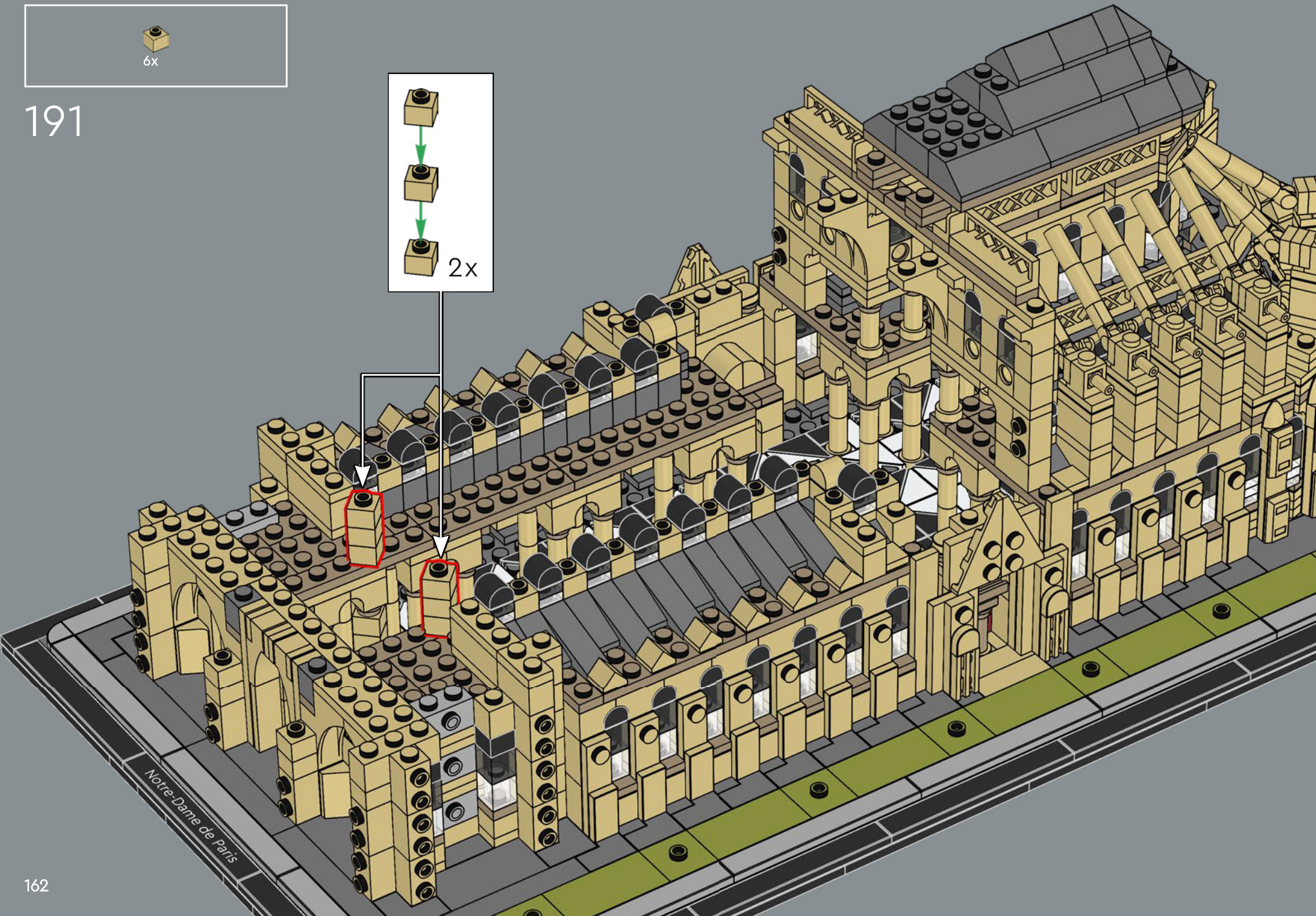
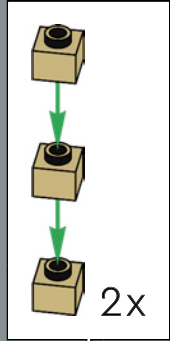

Notre-Dame de Paris

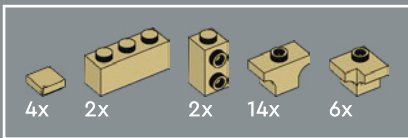

192

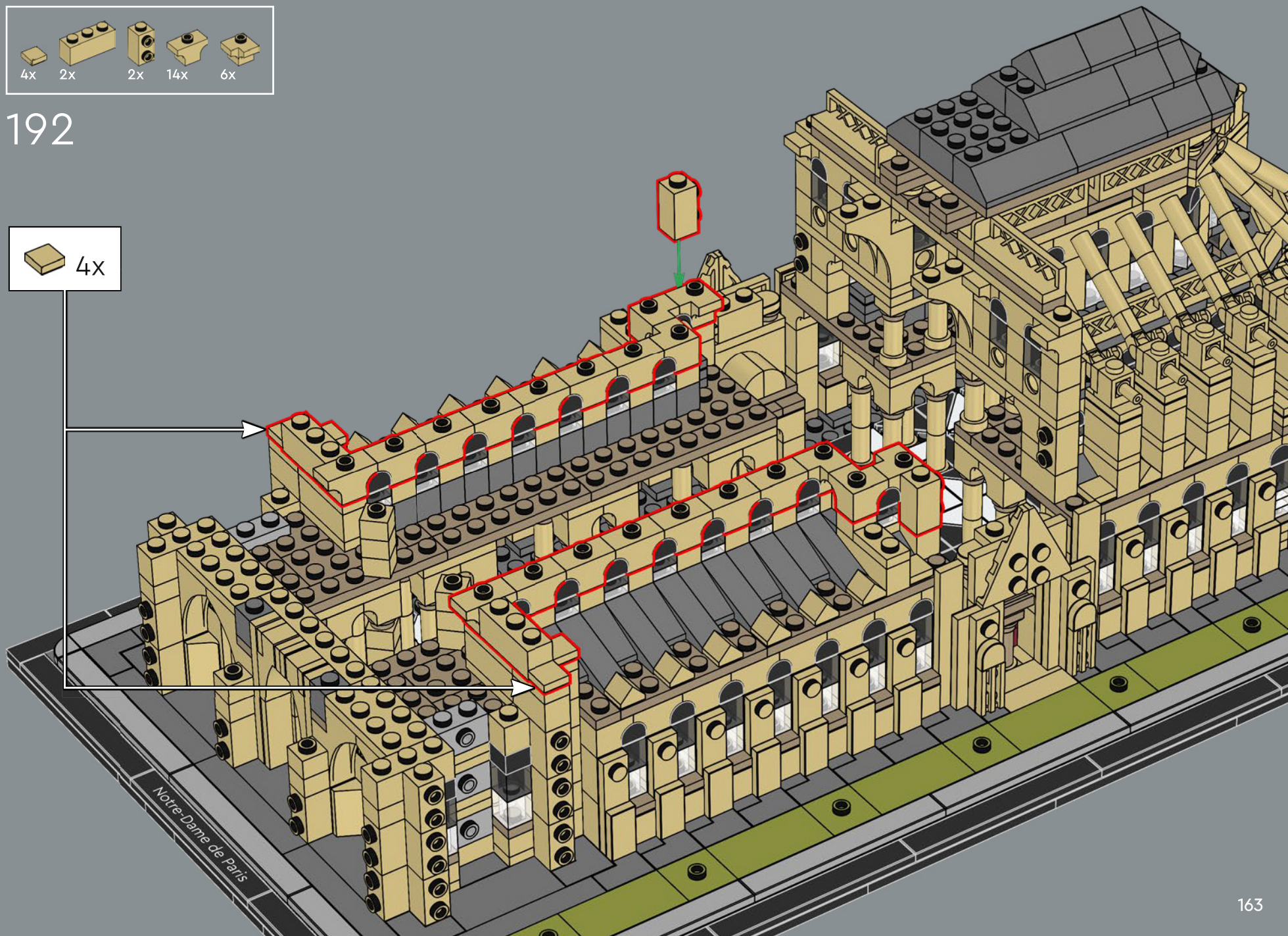

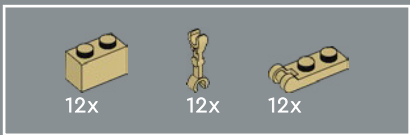

193

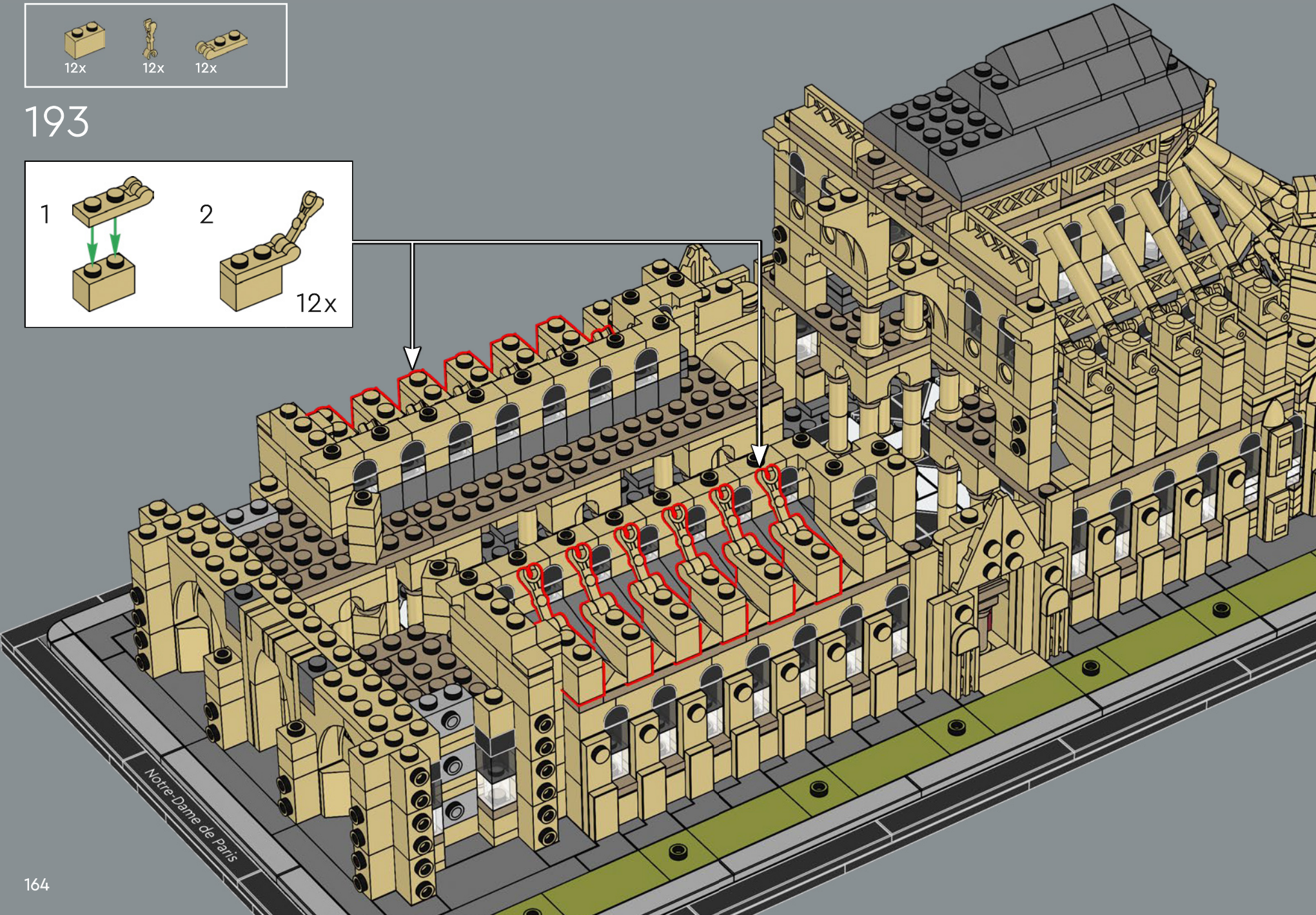
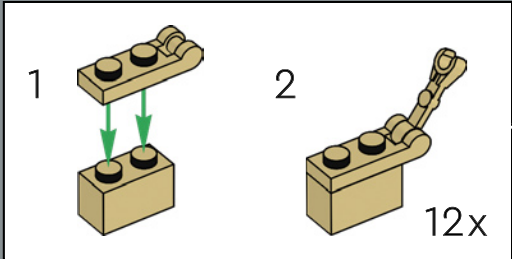



194

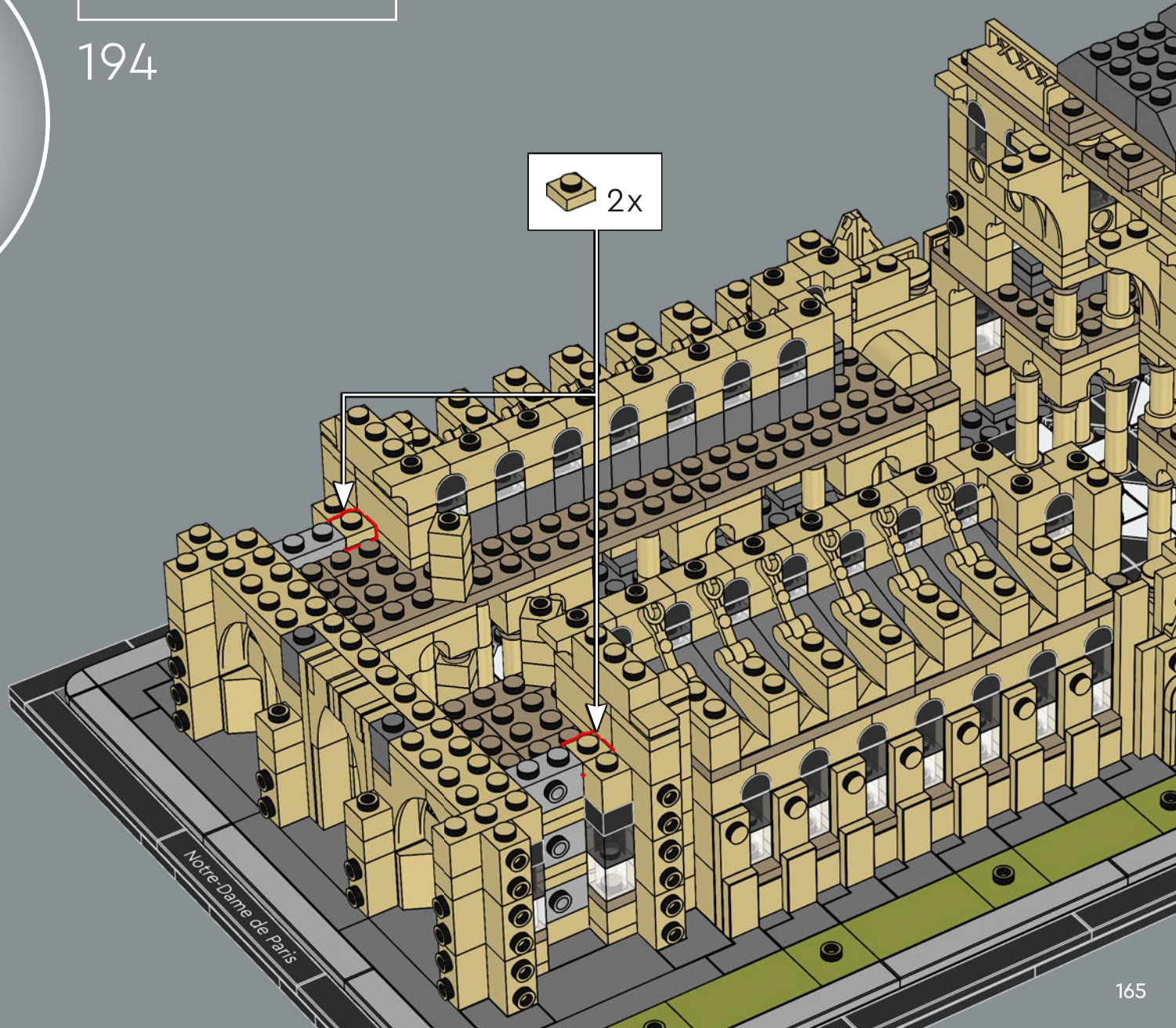

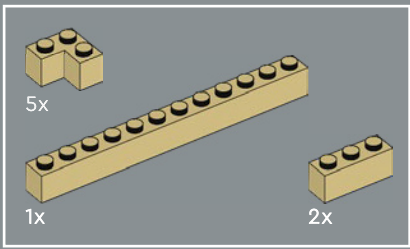

195

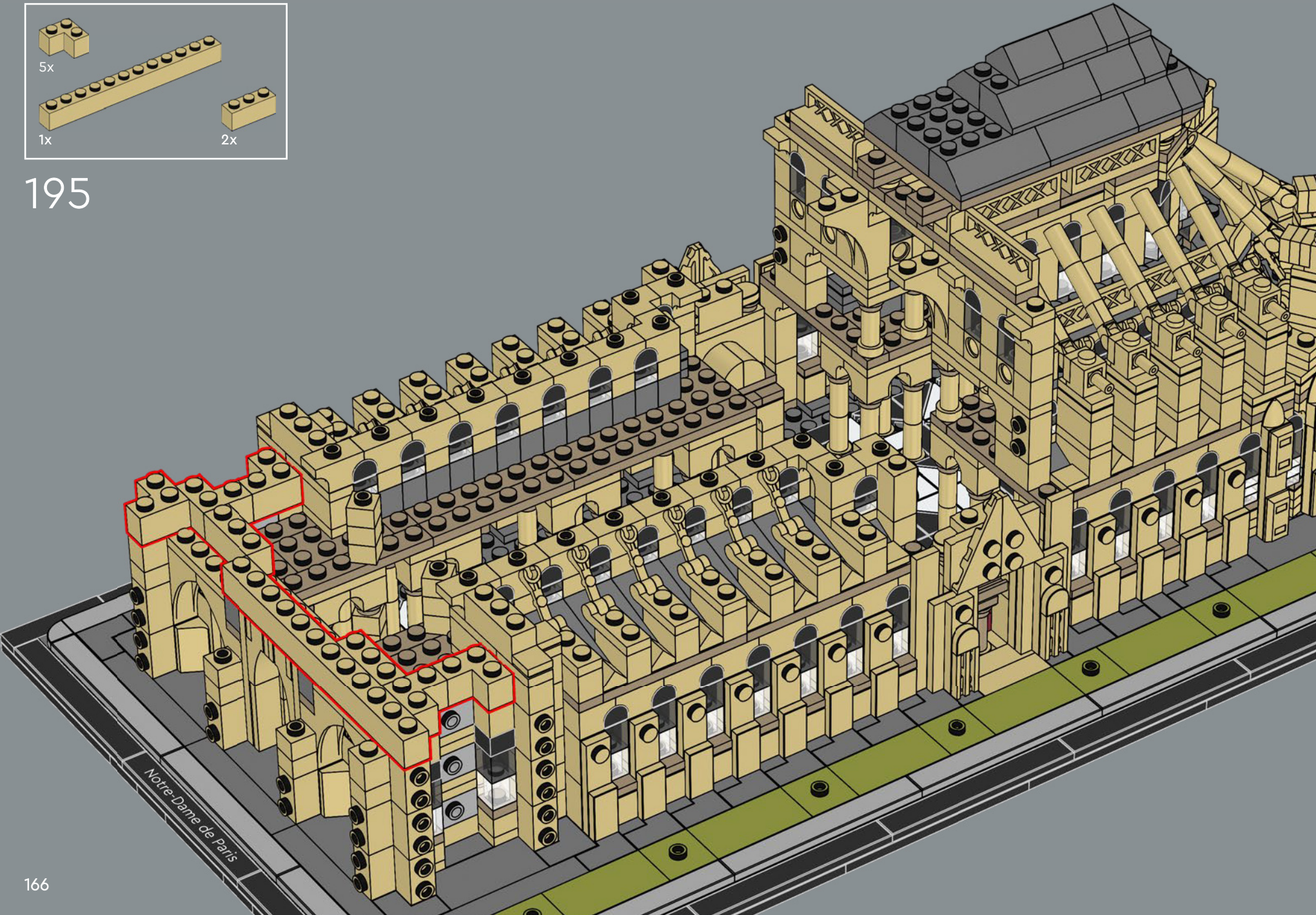

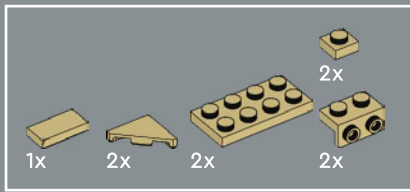

196

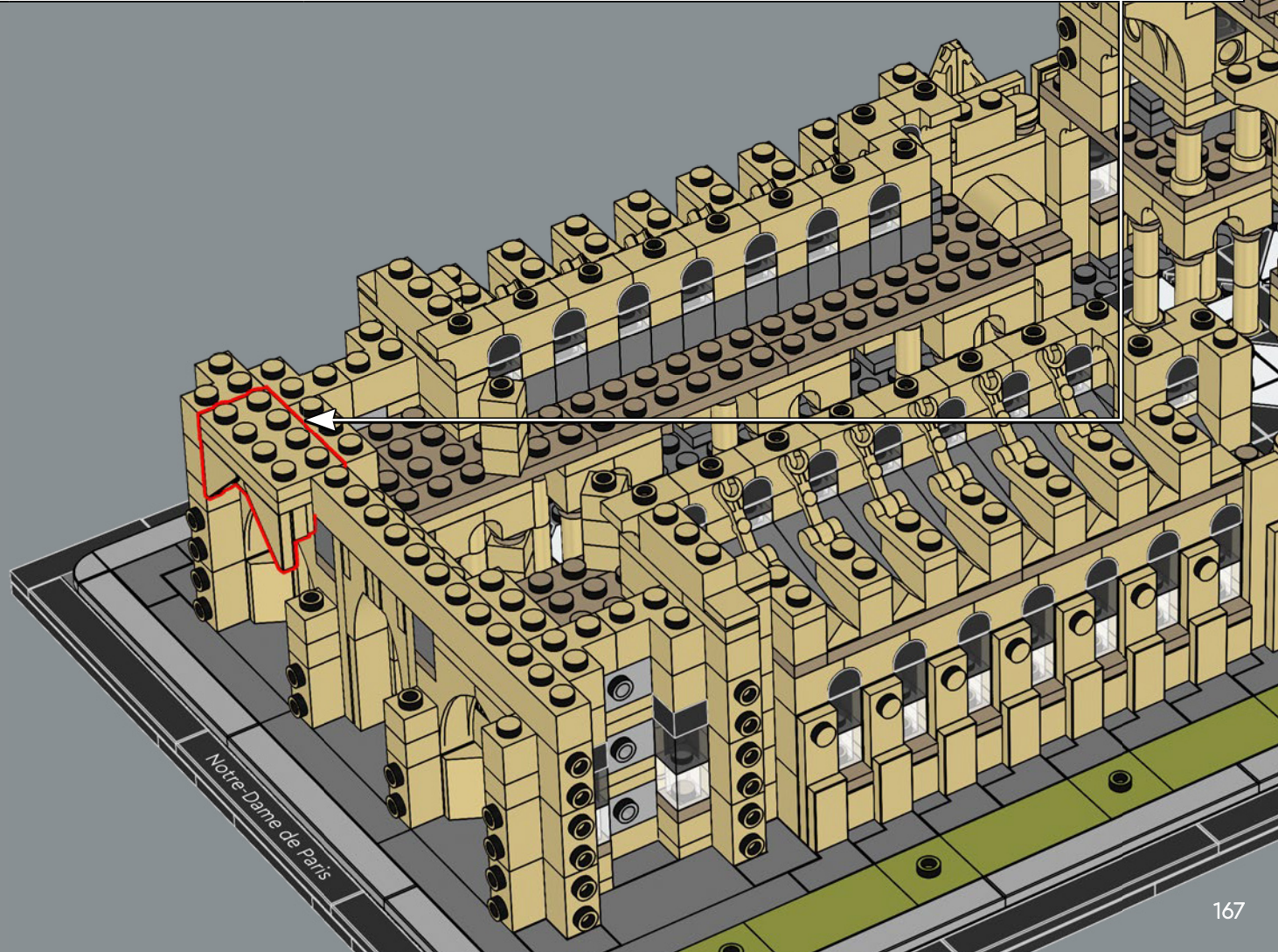
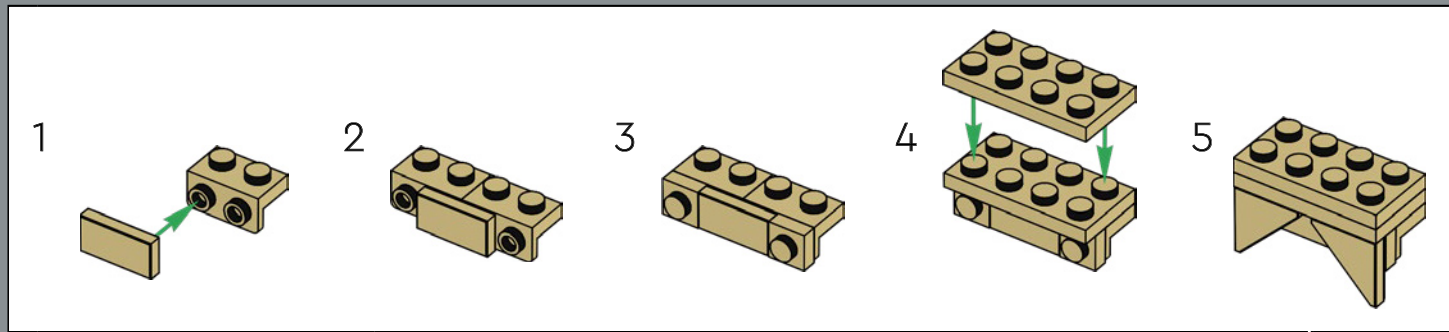

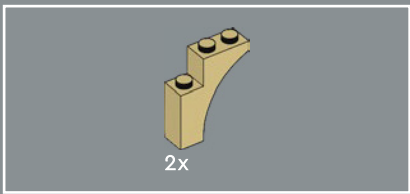

197

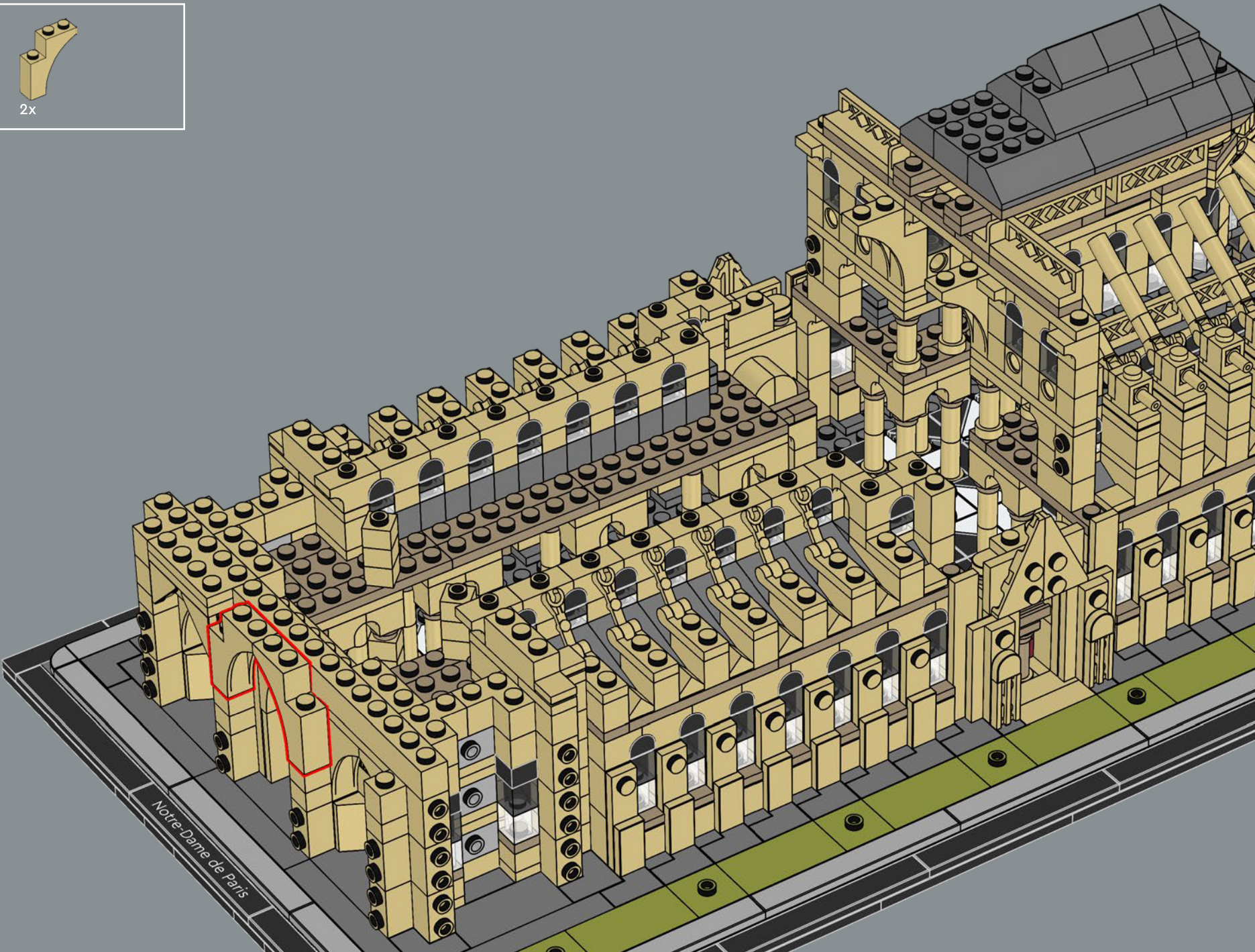

Notre-Dame de Paris

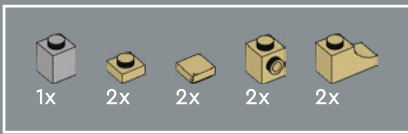

198

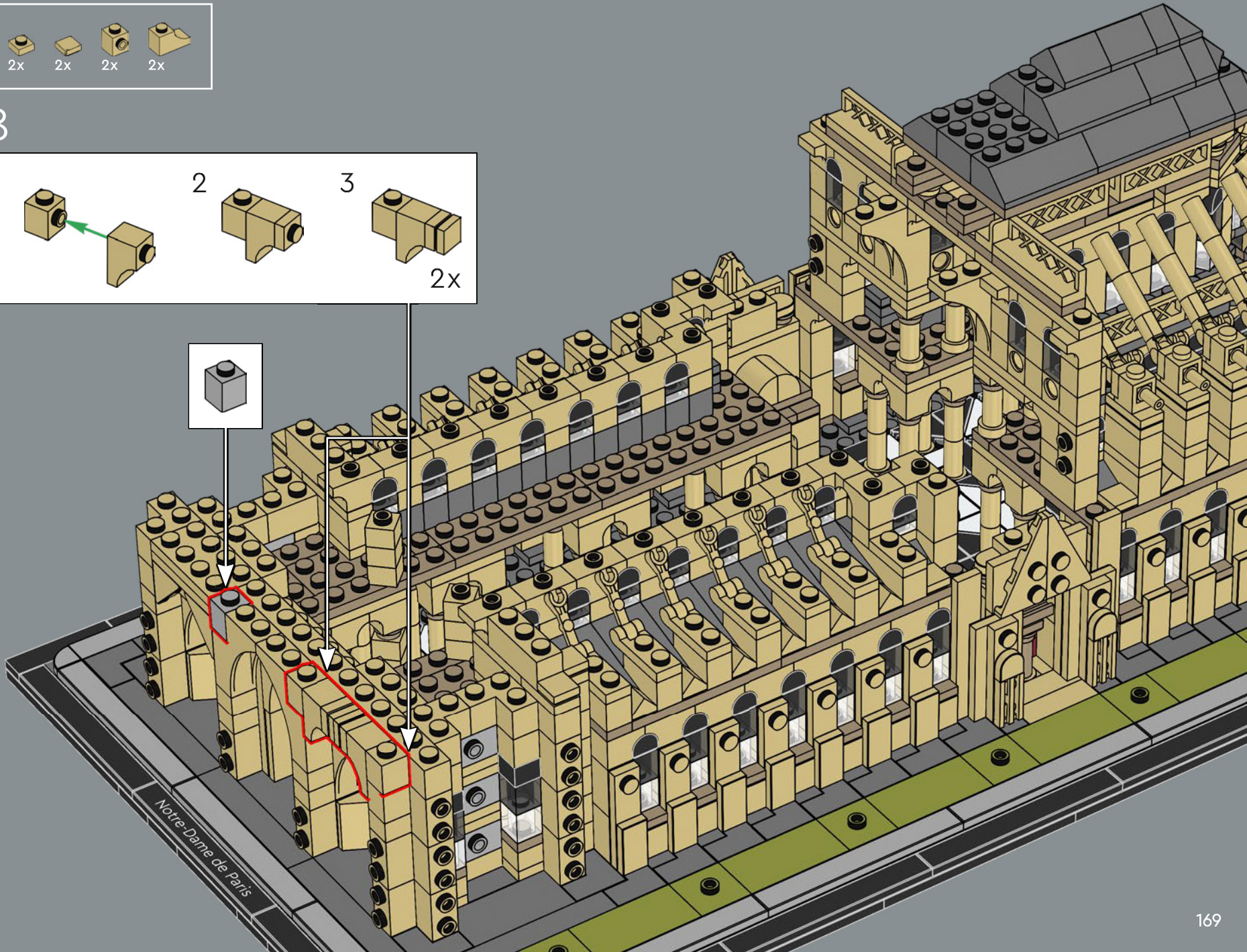
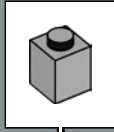
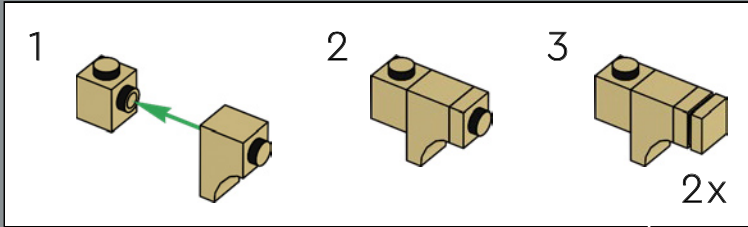

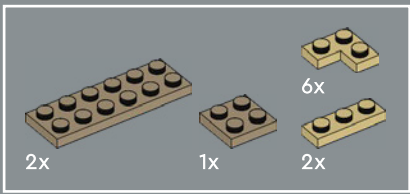

199



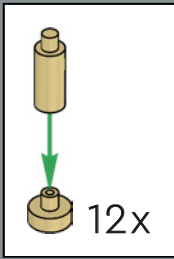

200



Notre-Dame de Paris

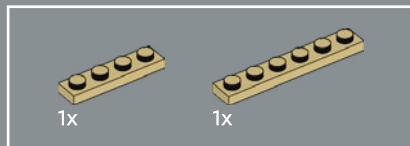
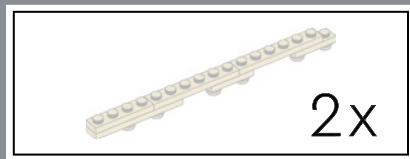

201

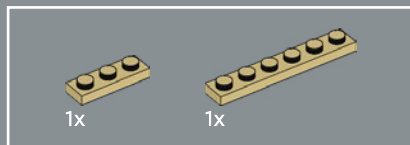
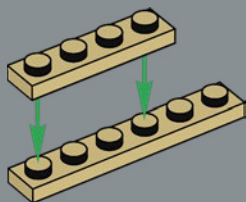

202

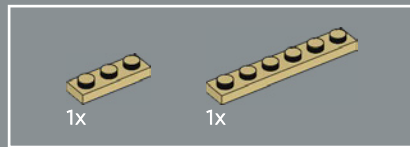
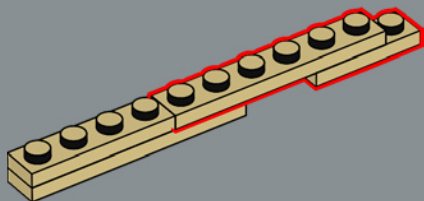

203

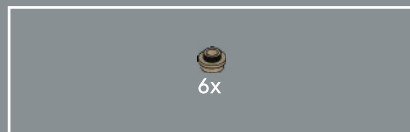
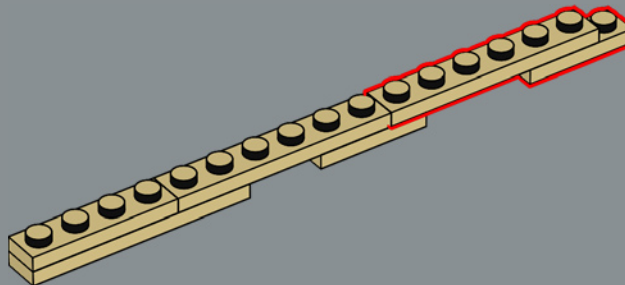

204

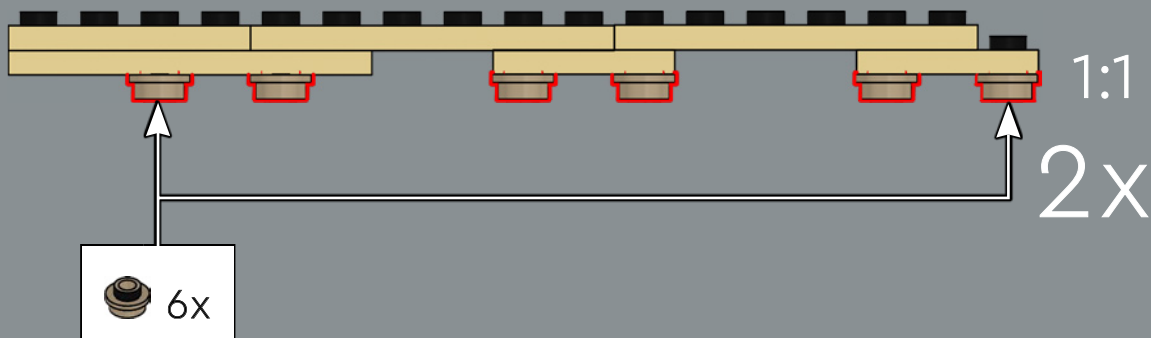

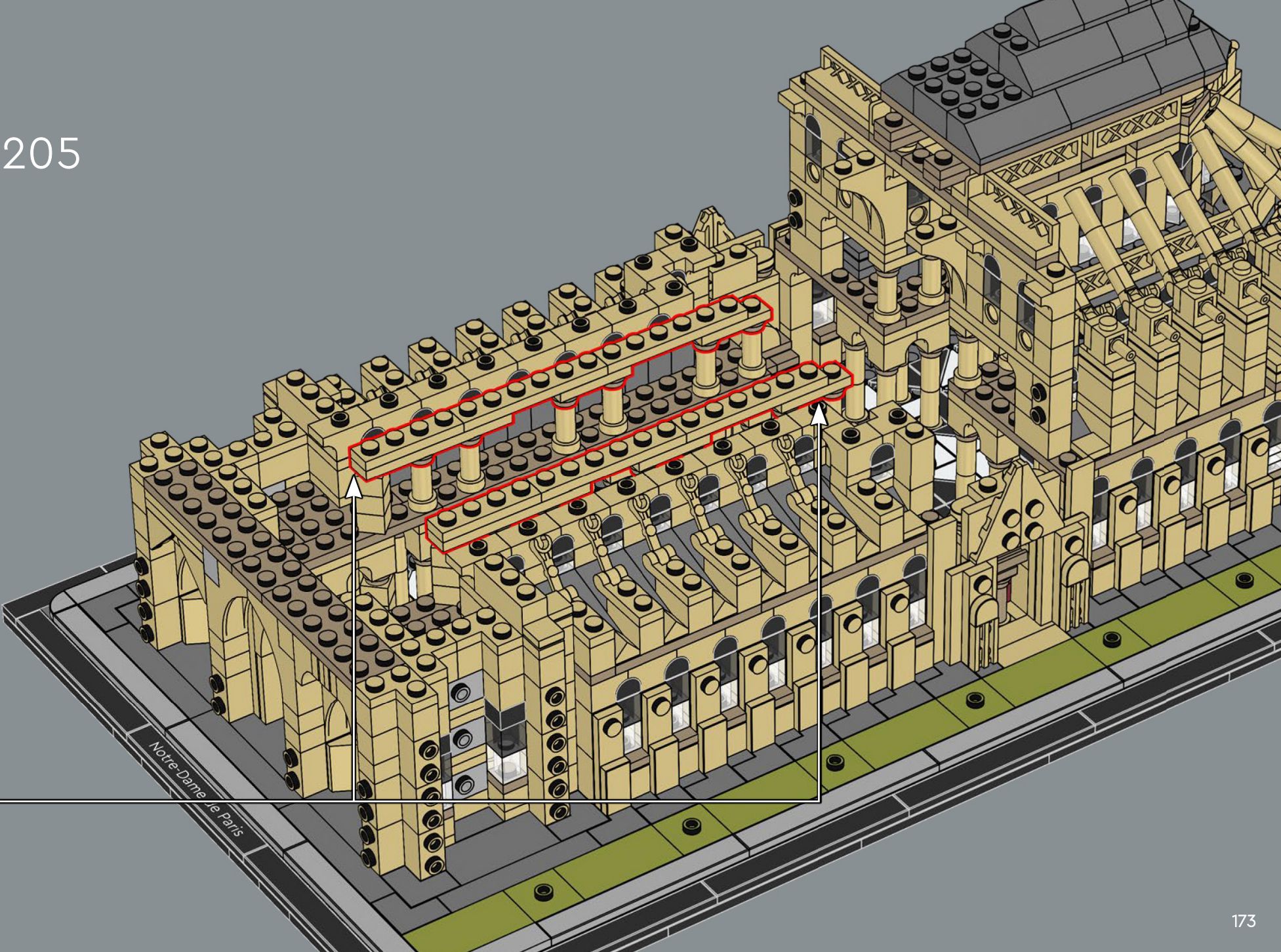

Notre-Dame
de Paris

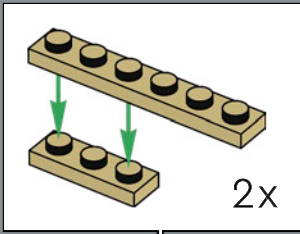
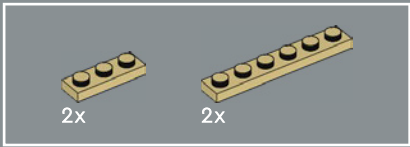

206

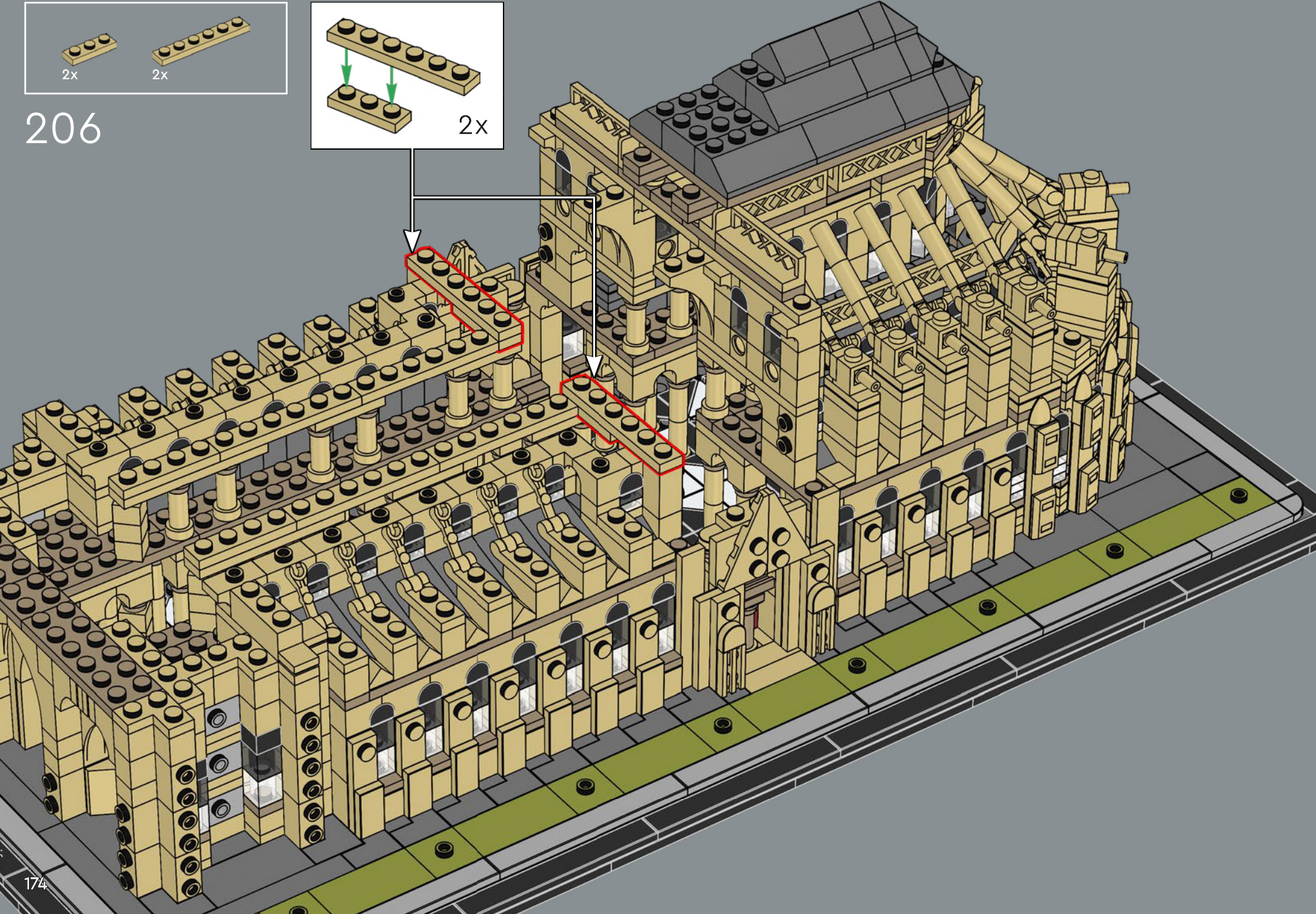

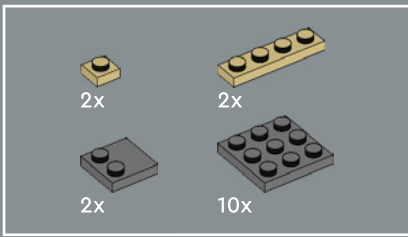

207



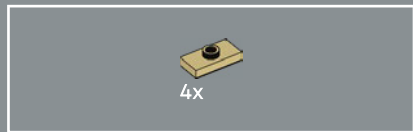

208

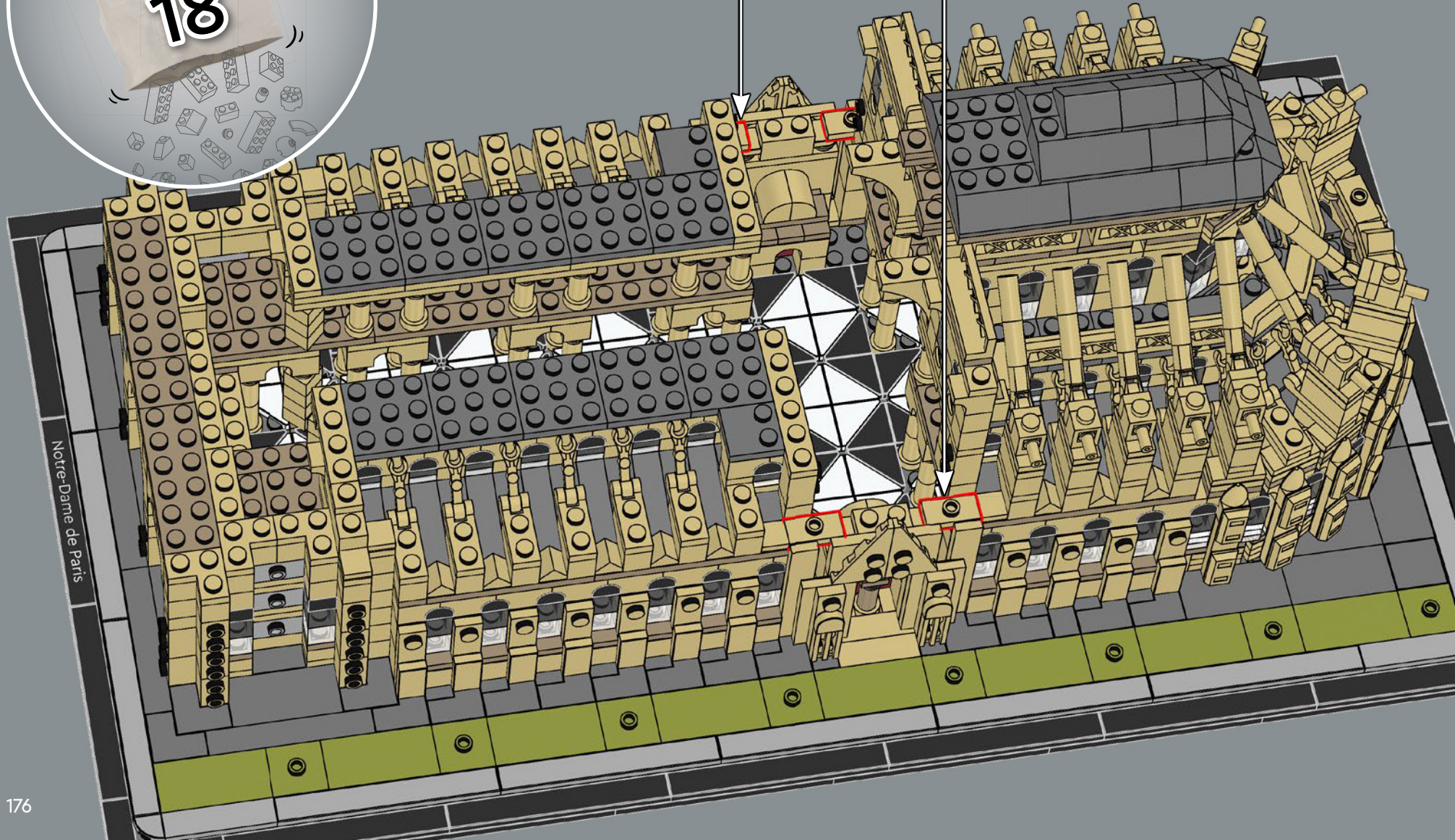

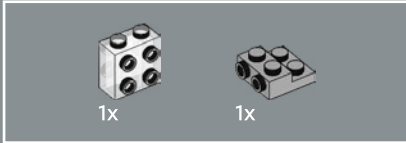
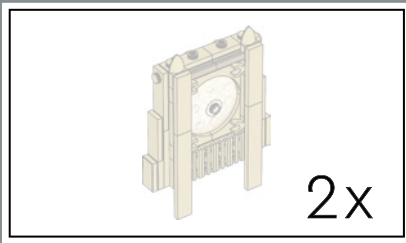

209

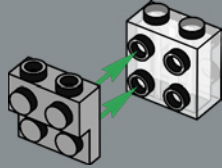

210

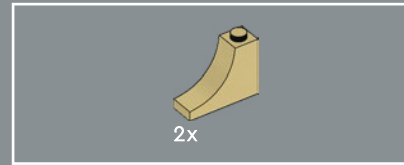
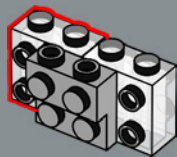

211

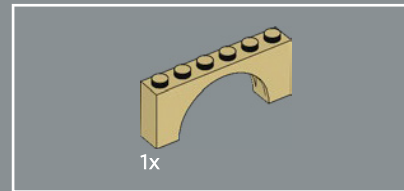
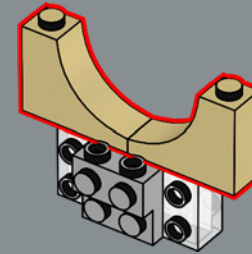

212

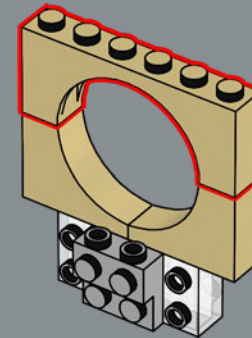

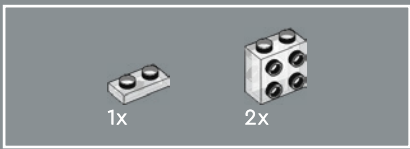

213

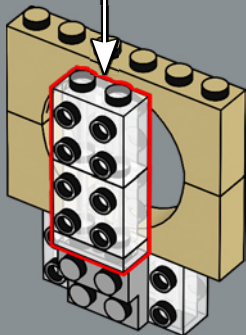
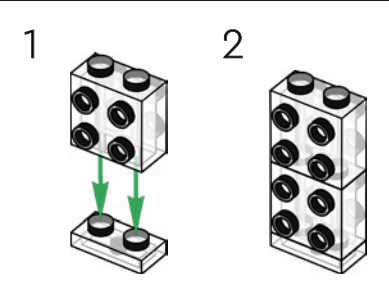

214

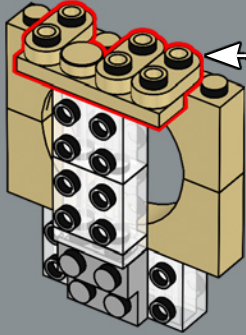
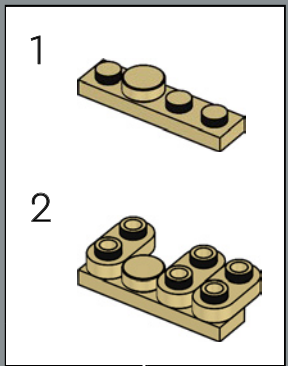

215

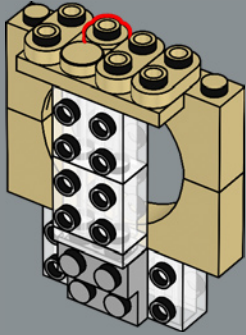



216

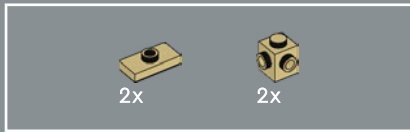
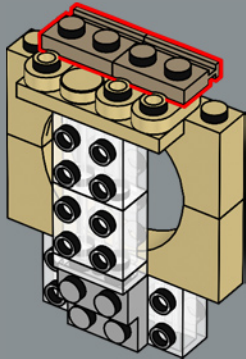

217

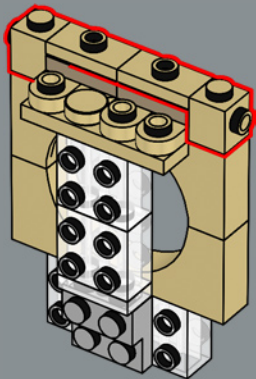

218

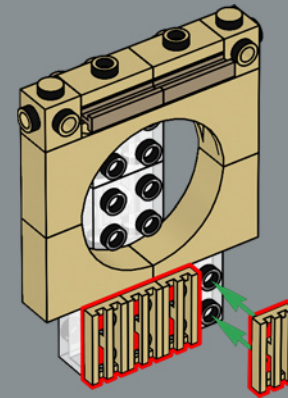

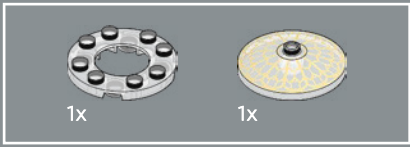

219

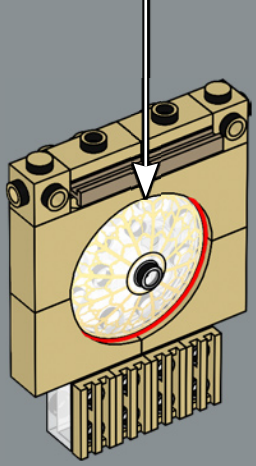
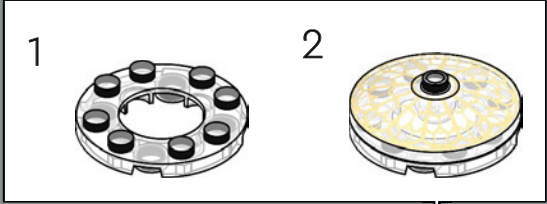

220

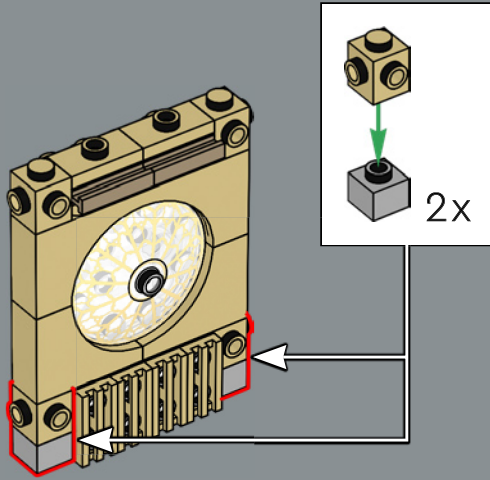

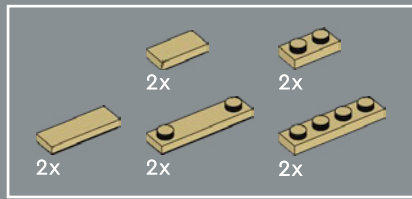

221

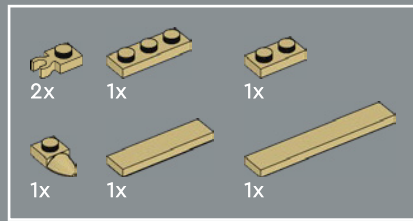
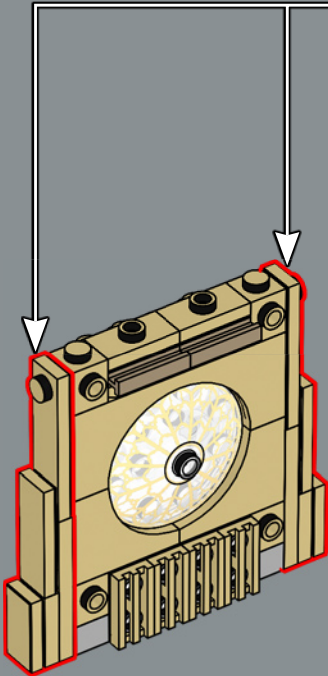
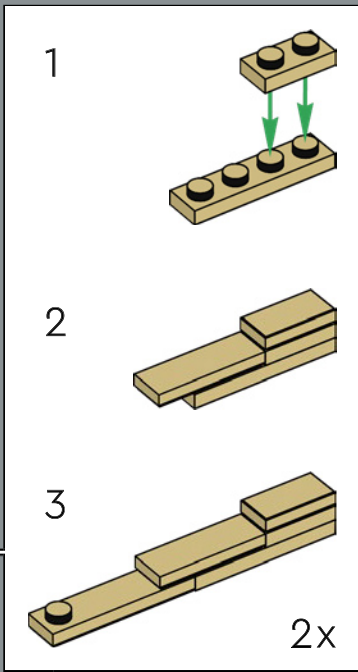

222

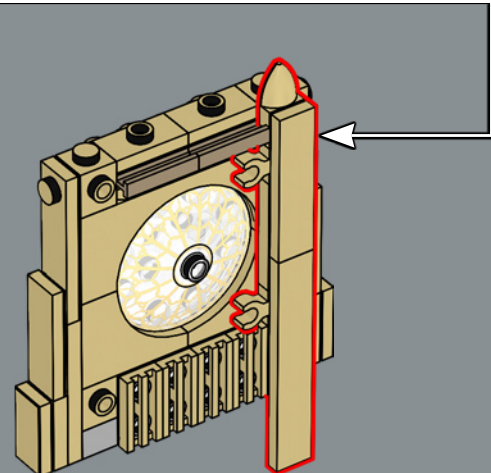
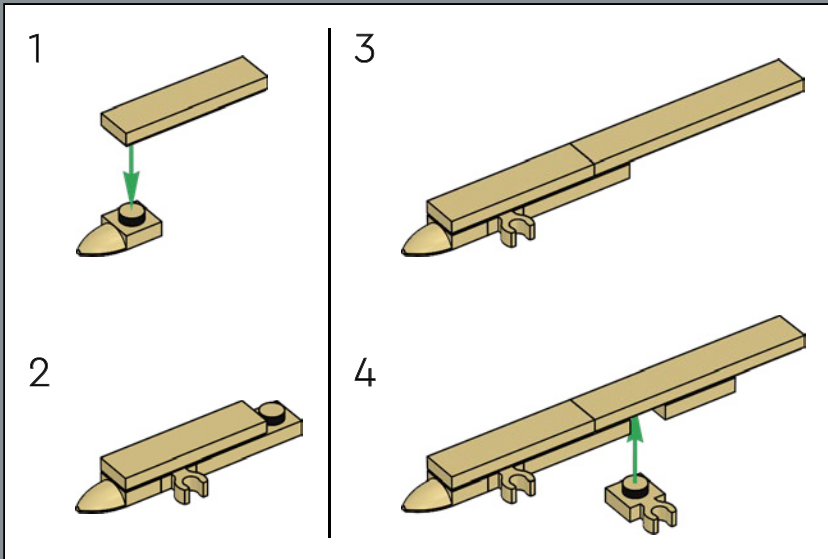

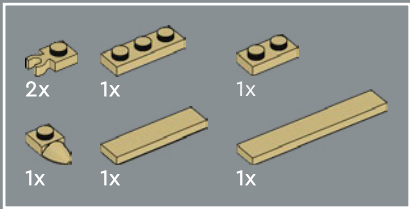

223

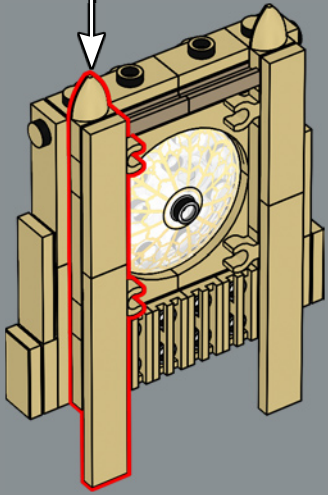
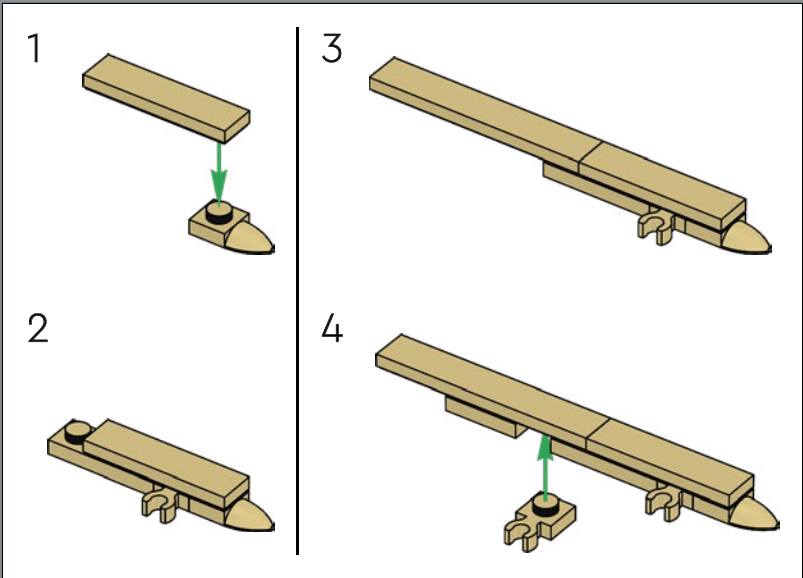

2x

224

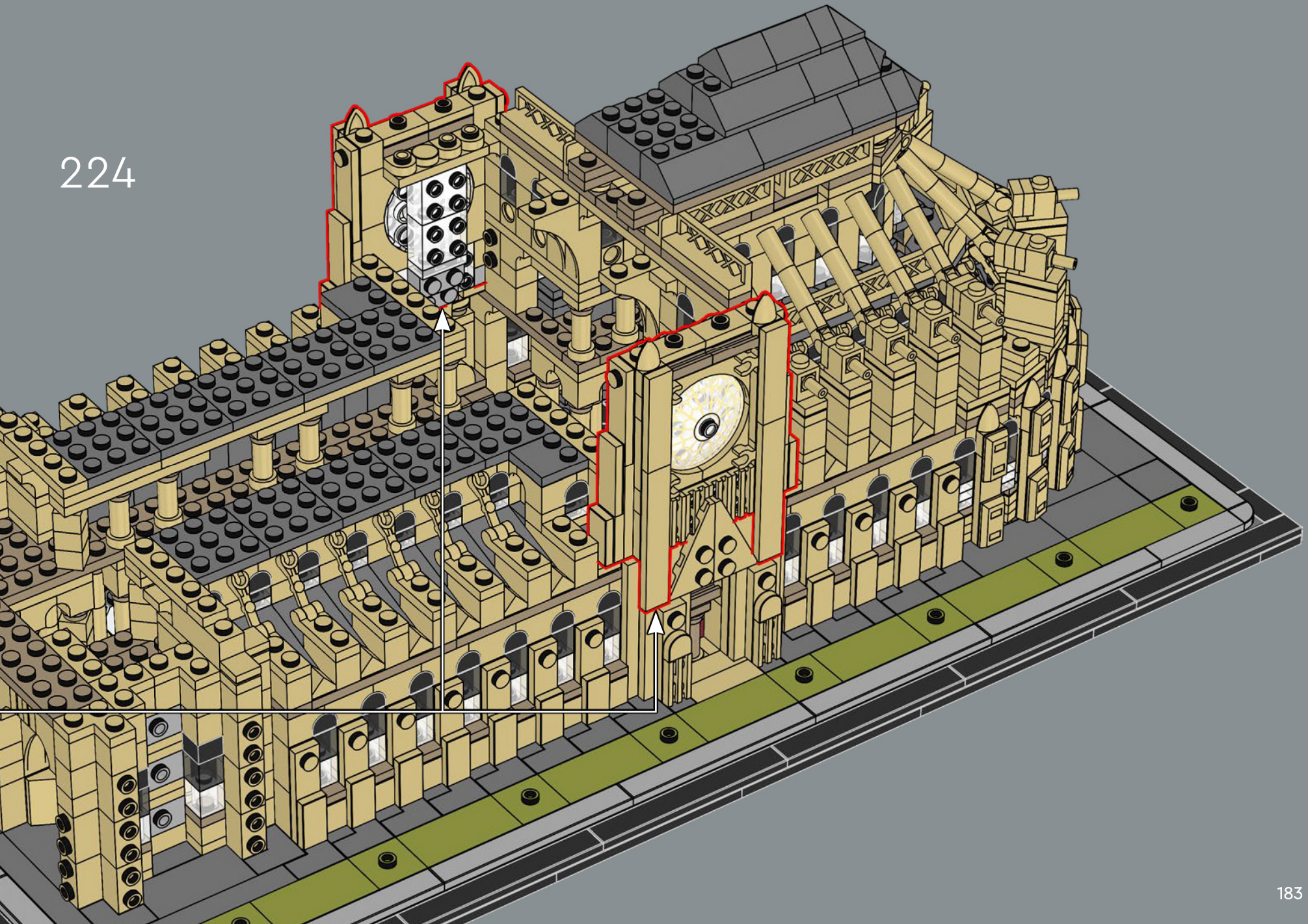

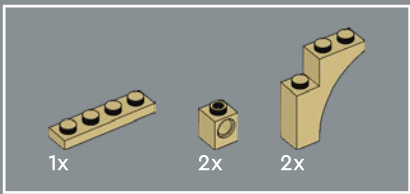

225

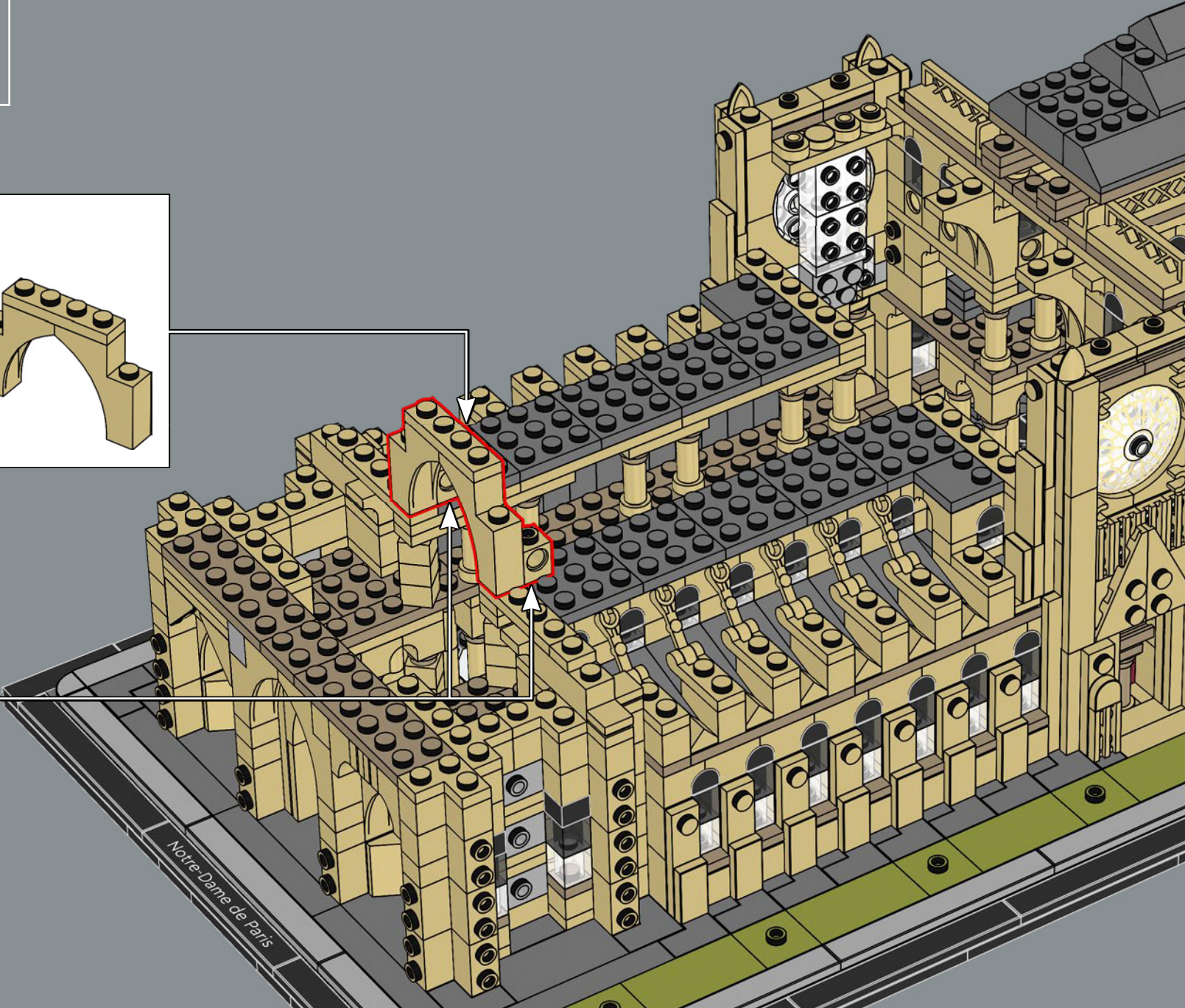
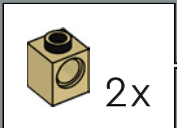
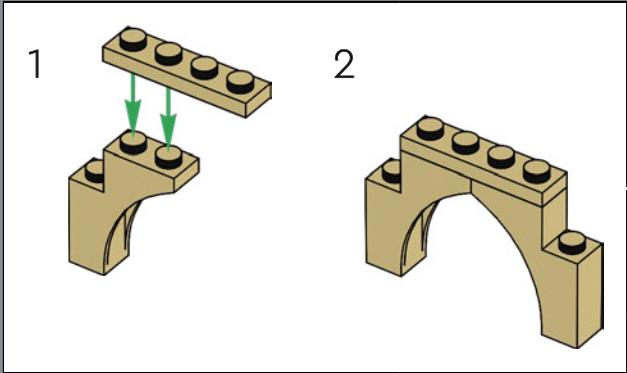

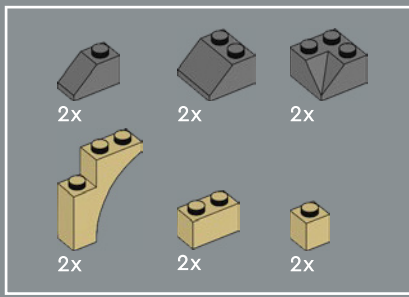

226

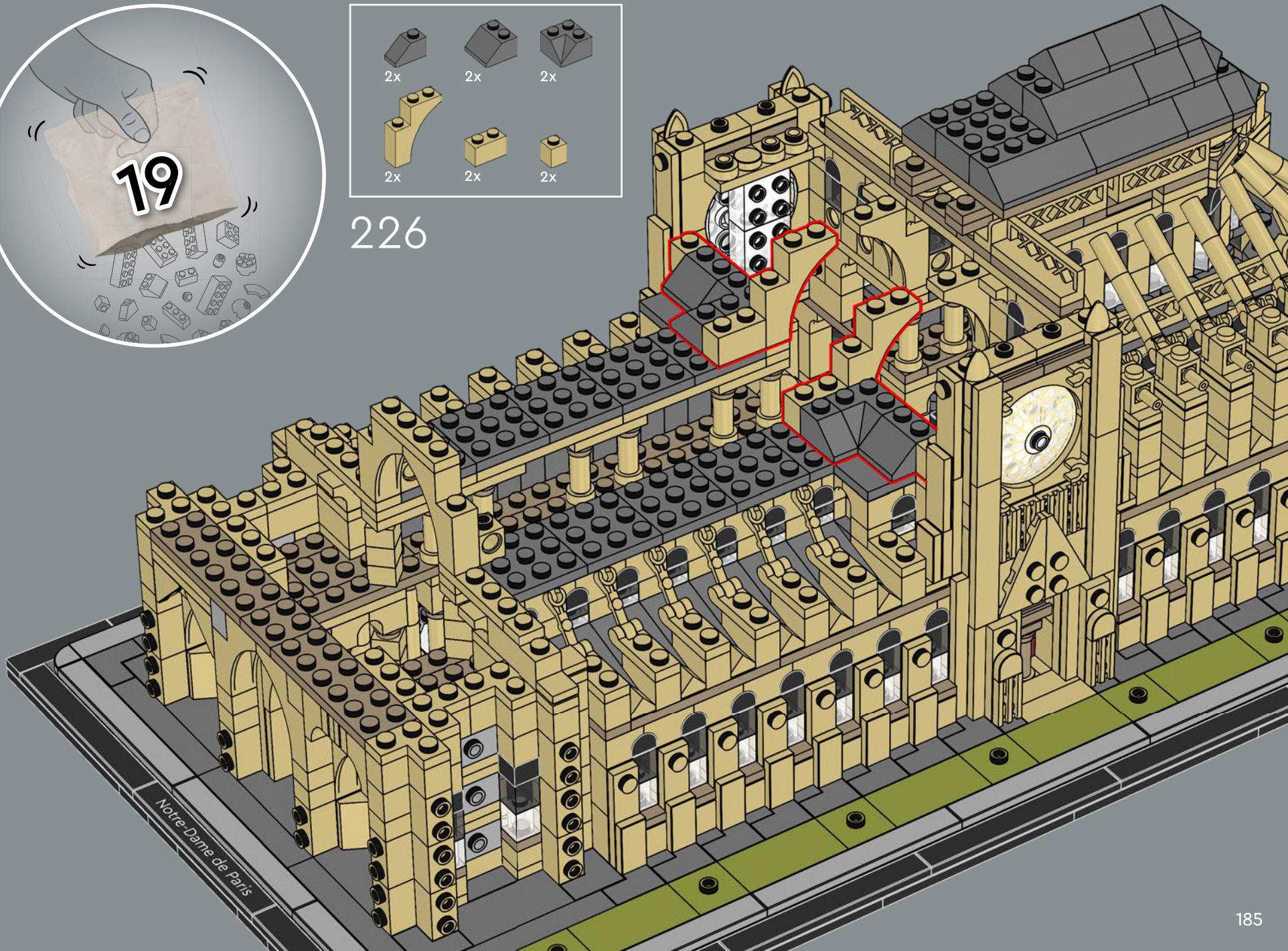

Notre-Dame de Paris



8x

227

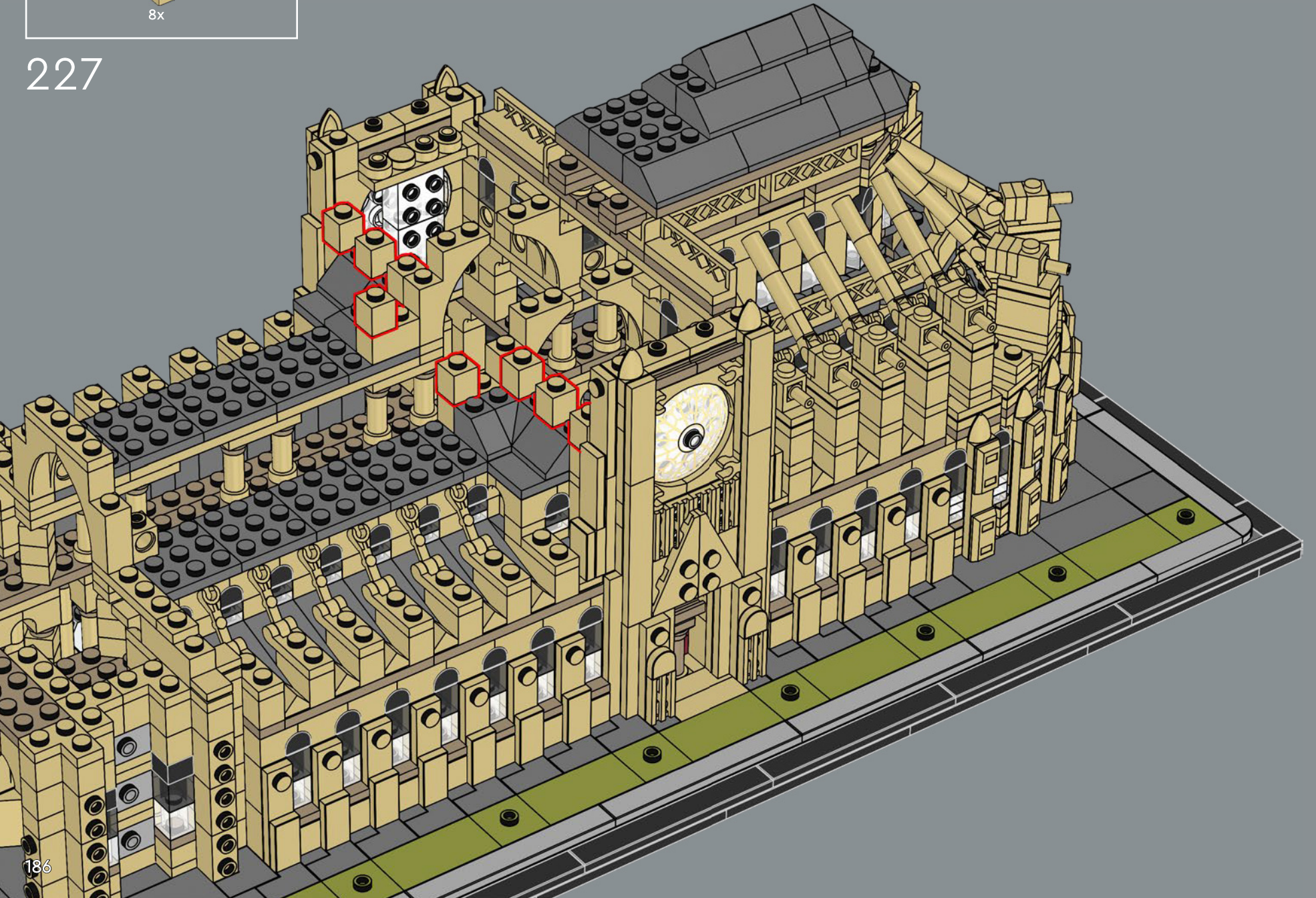

穹顶被肋骨拱分为六个部分——“六分肋骨拱”。
乐高®模型遵循原始建筑，每第二个柱顶就有一个横肋。

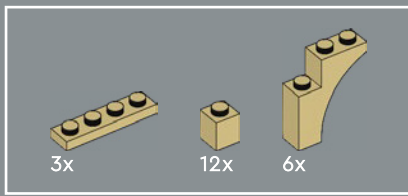

228

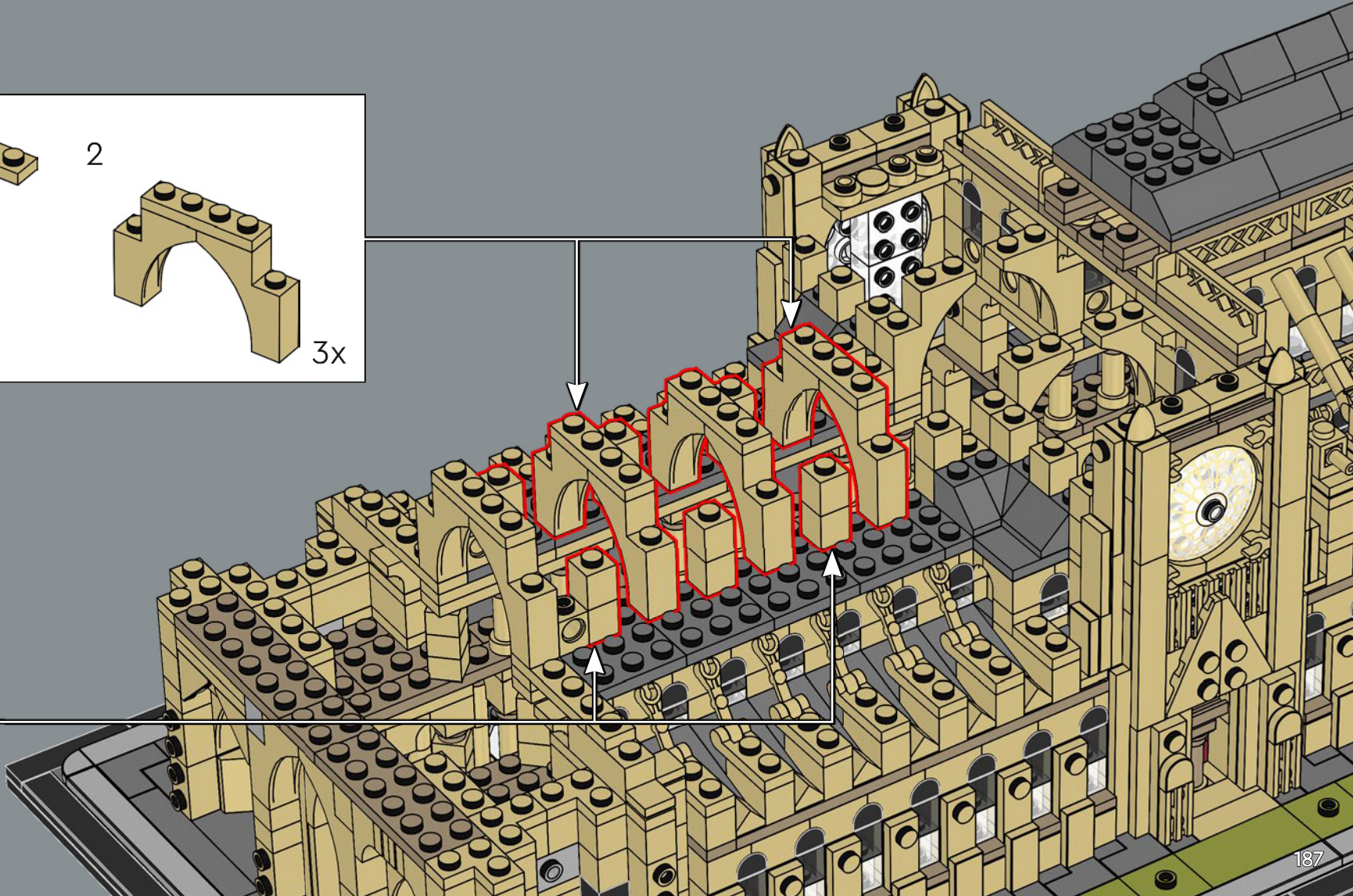
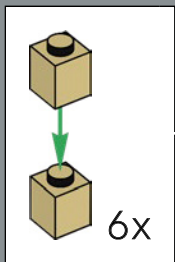
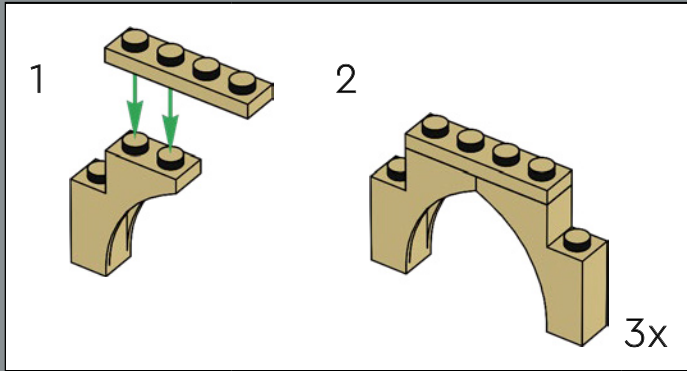



12x



20x



20x

229



8x



12x

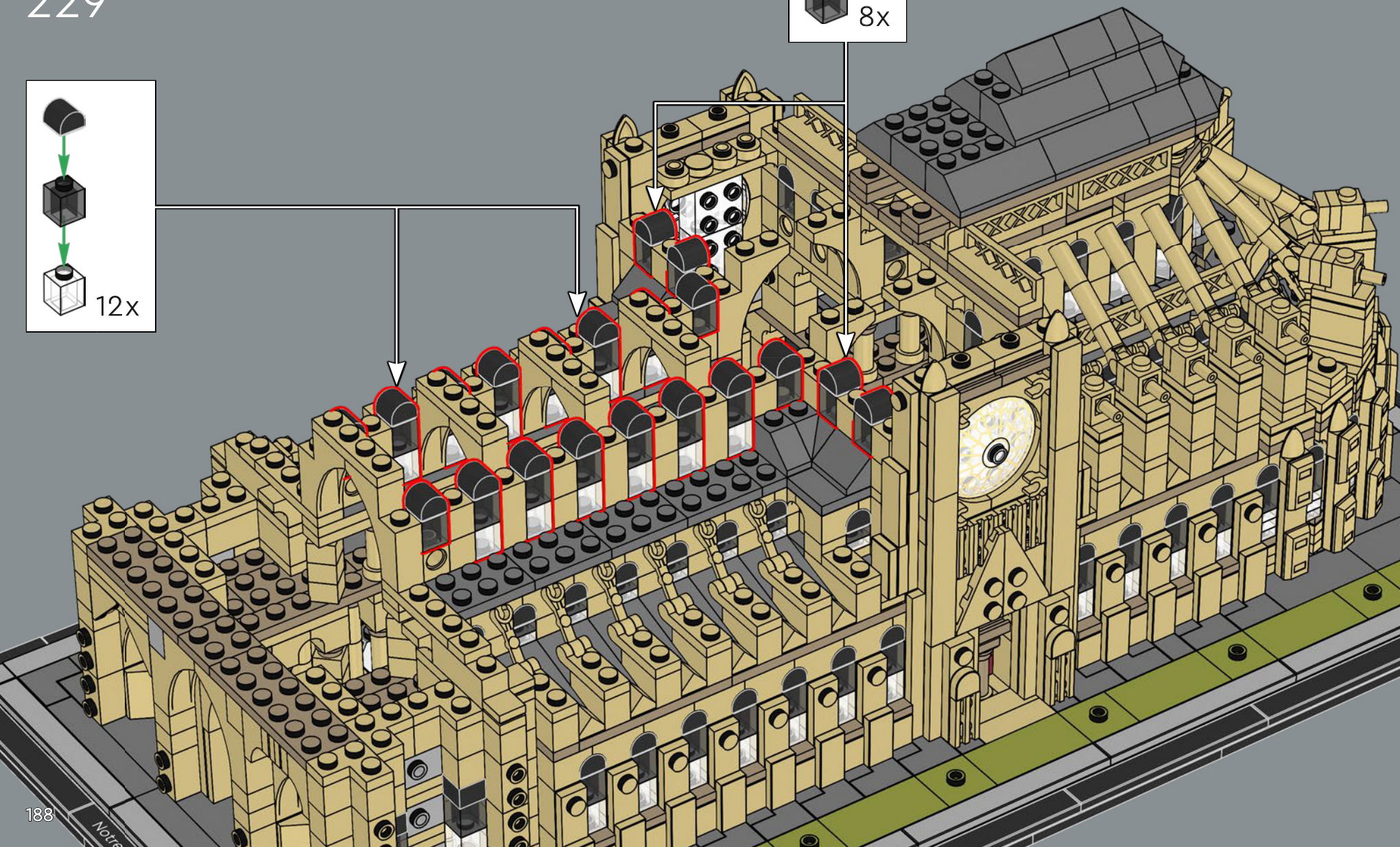

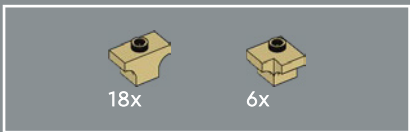

230

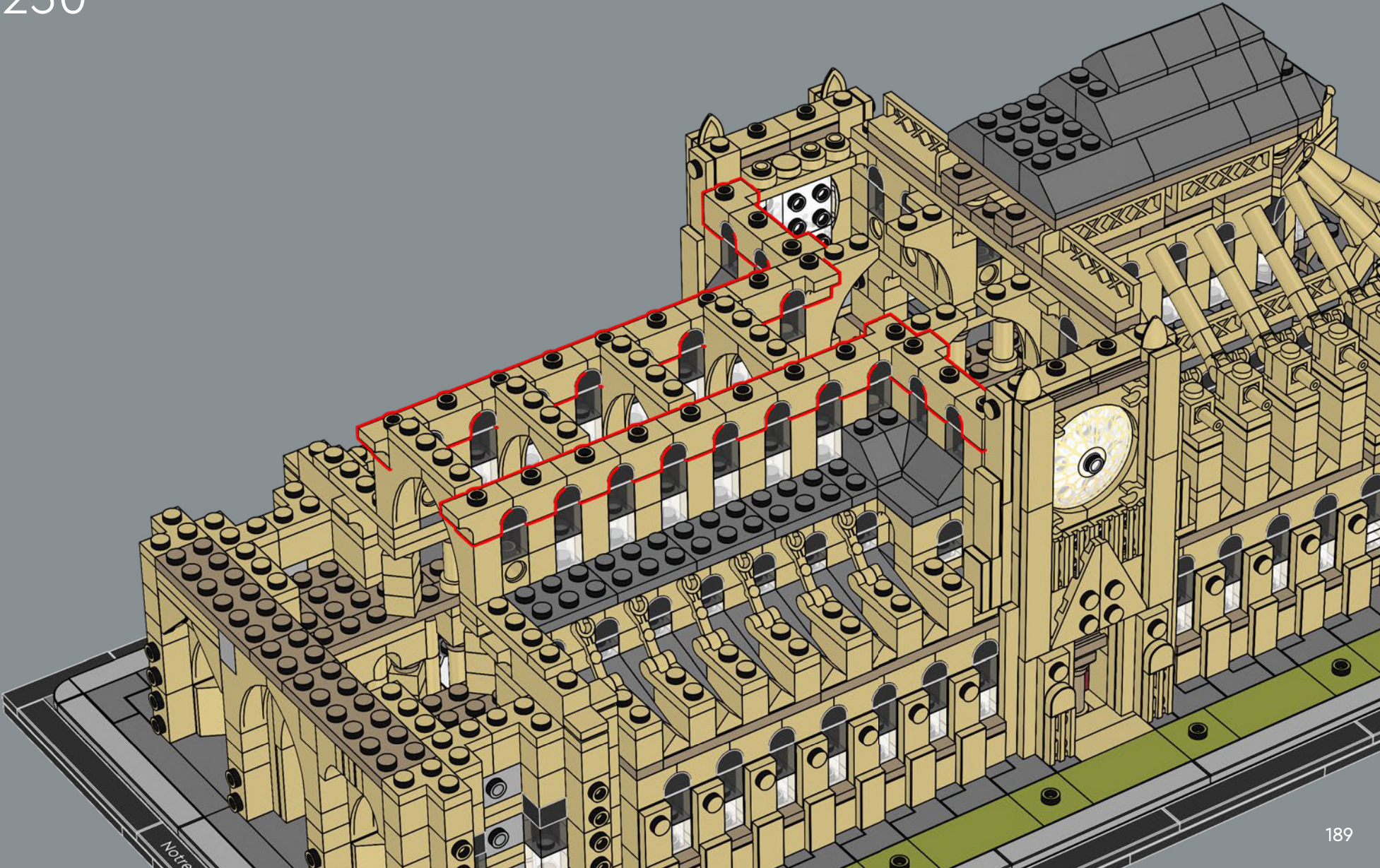

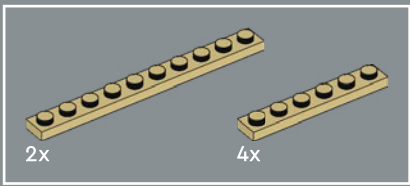

231

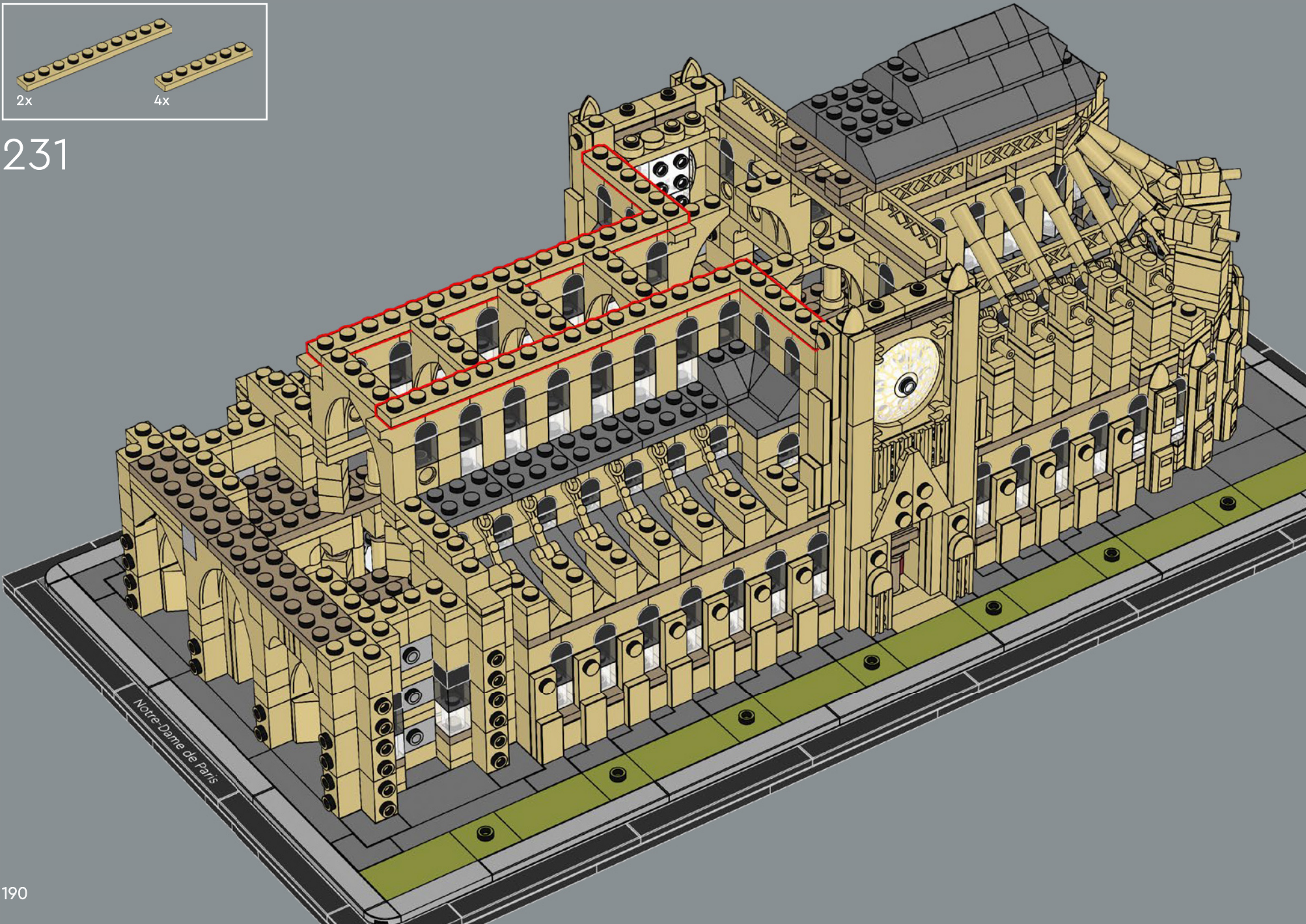

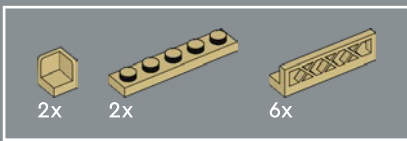

232

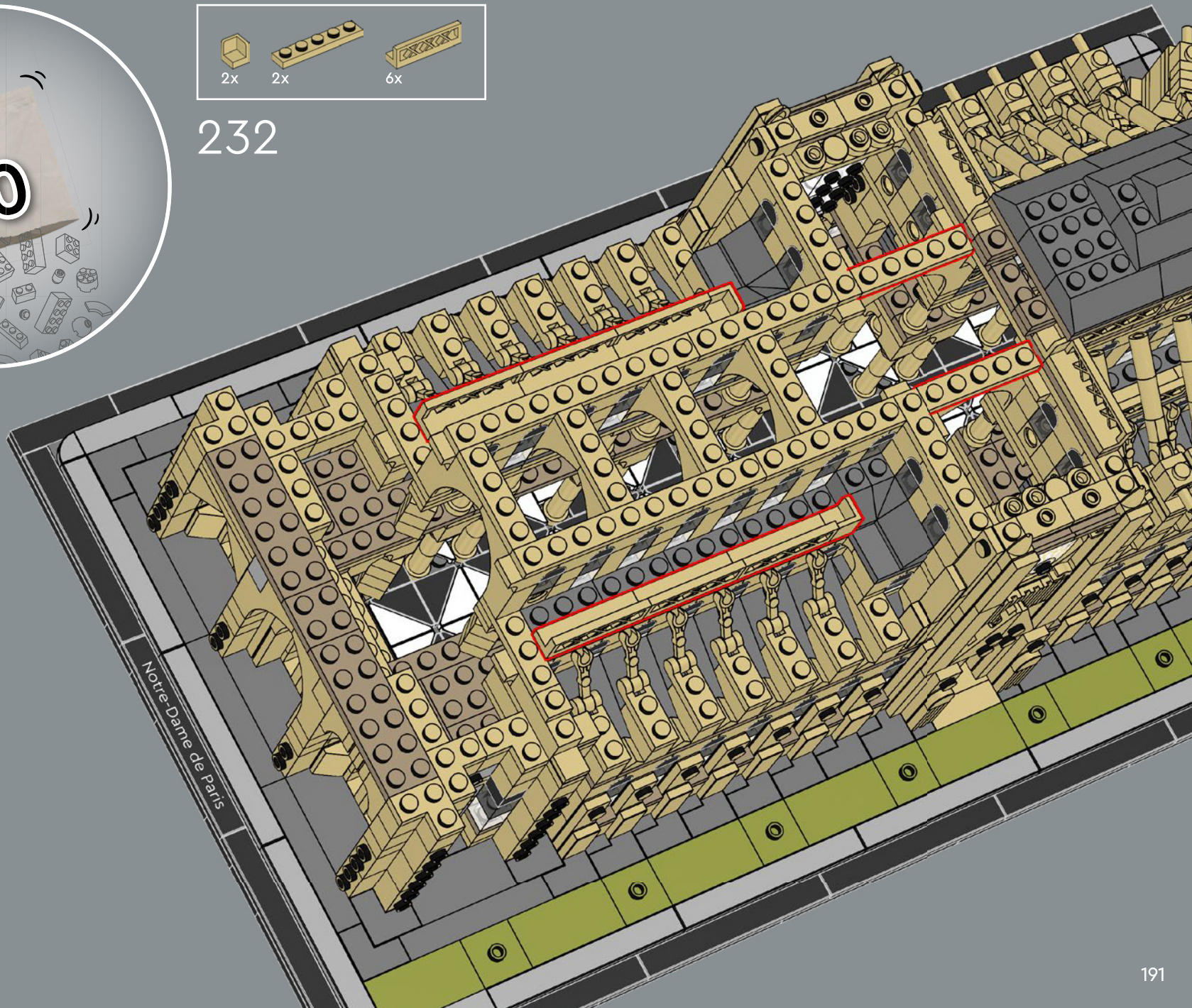

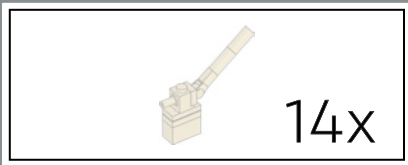

这款乐高®模型包含穿过蜡烛组件的孔洞，以模仿真实飞扶壁中的排水道。

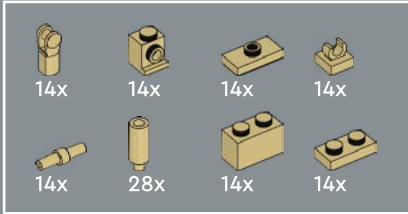

233

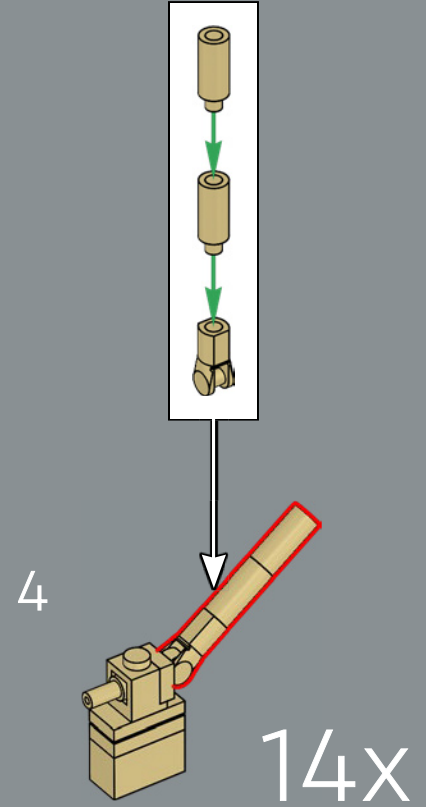
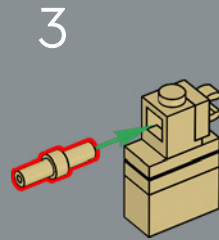
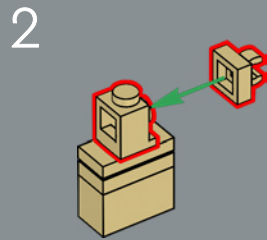
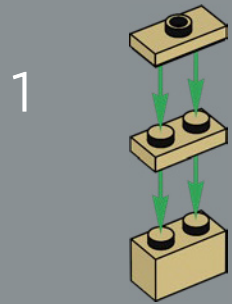

1225 年，中堂飞扶壁装设有通道，
其通过滴水兽将屋顶的雨水排出。

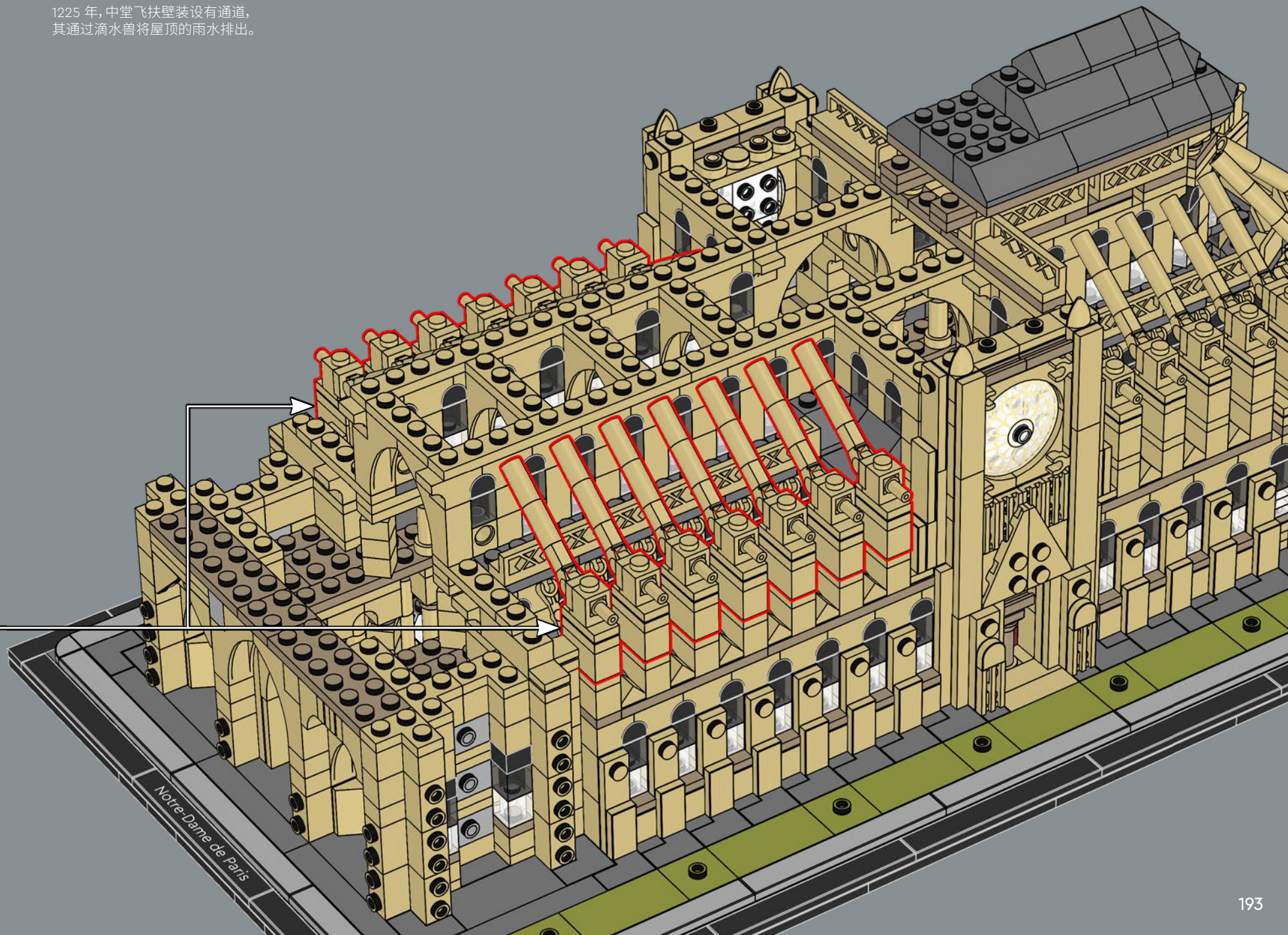

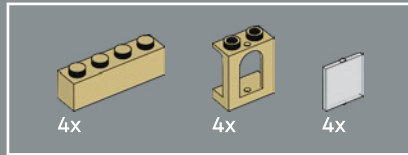
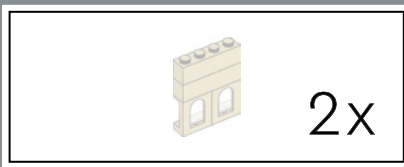

234

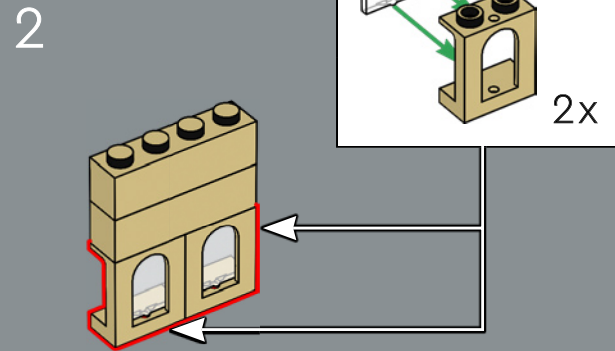
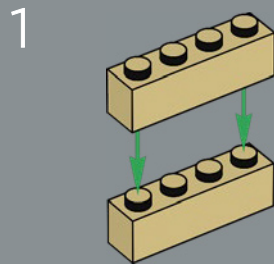

2x

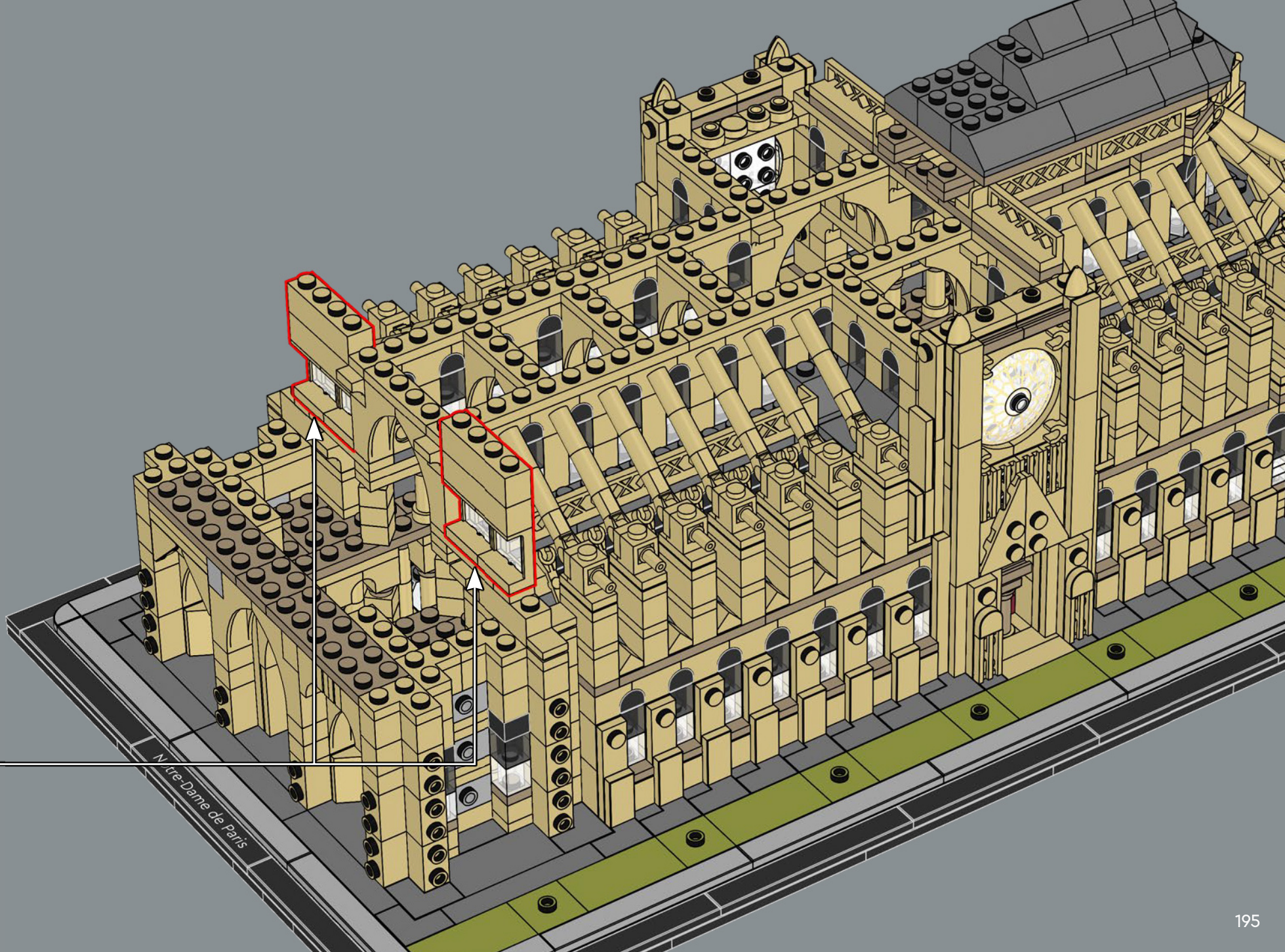

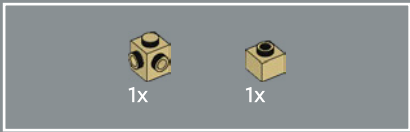

235

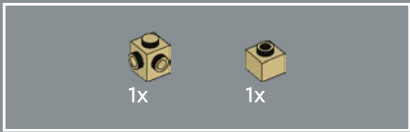
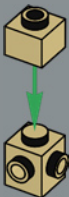

236

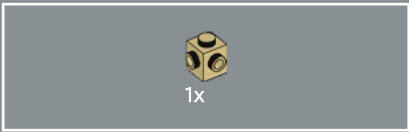

237

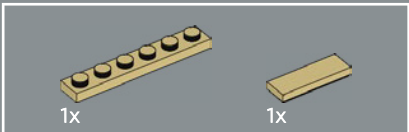

238

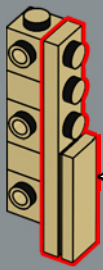
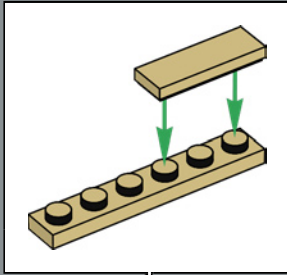

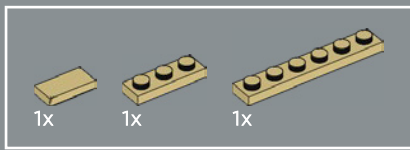

239

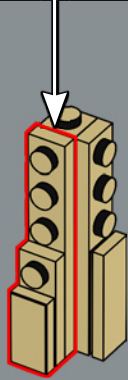
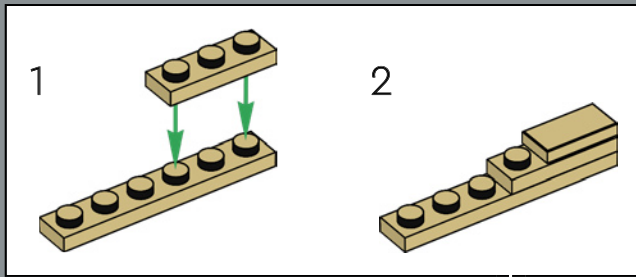

240

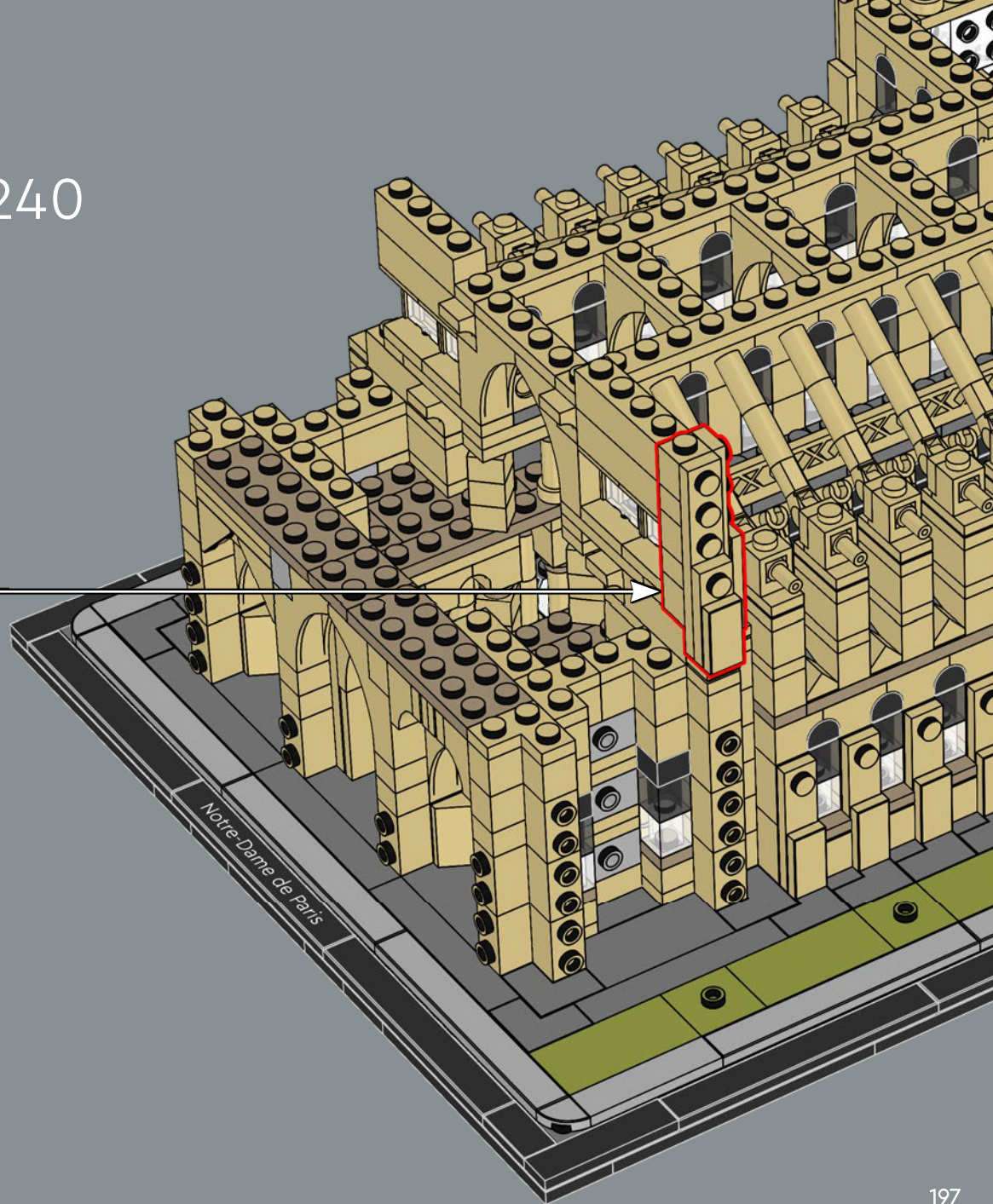

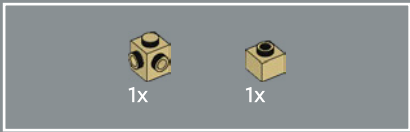

241

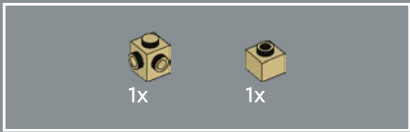
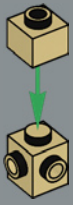

242

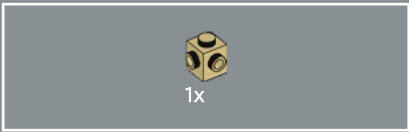

243

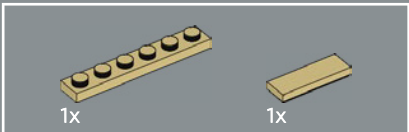

244

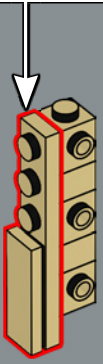
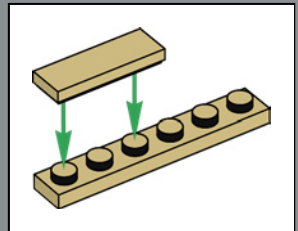

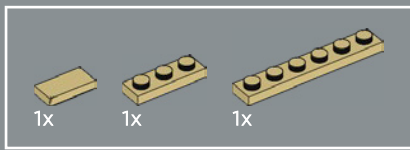

245

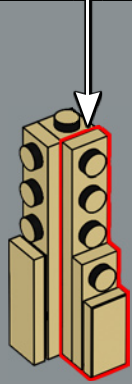
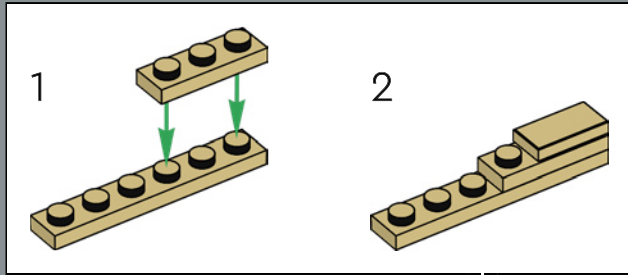

246

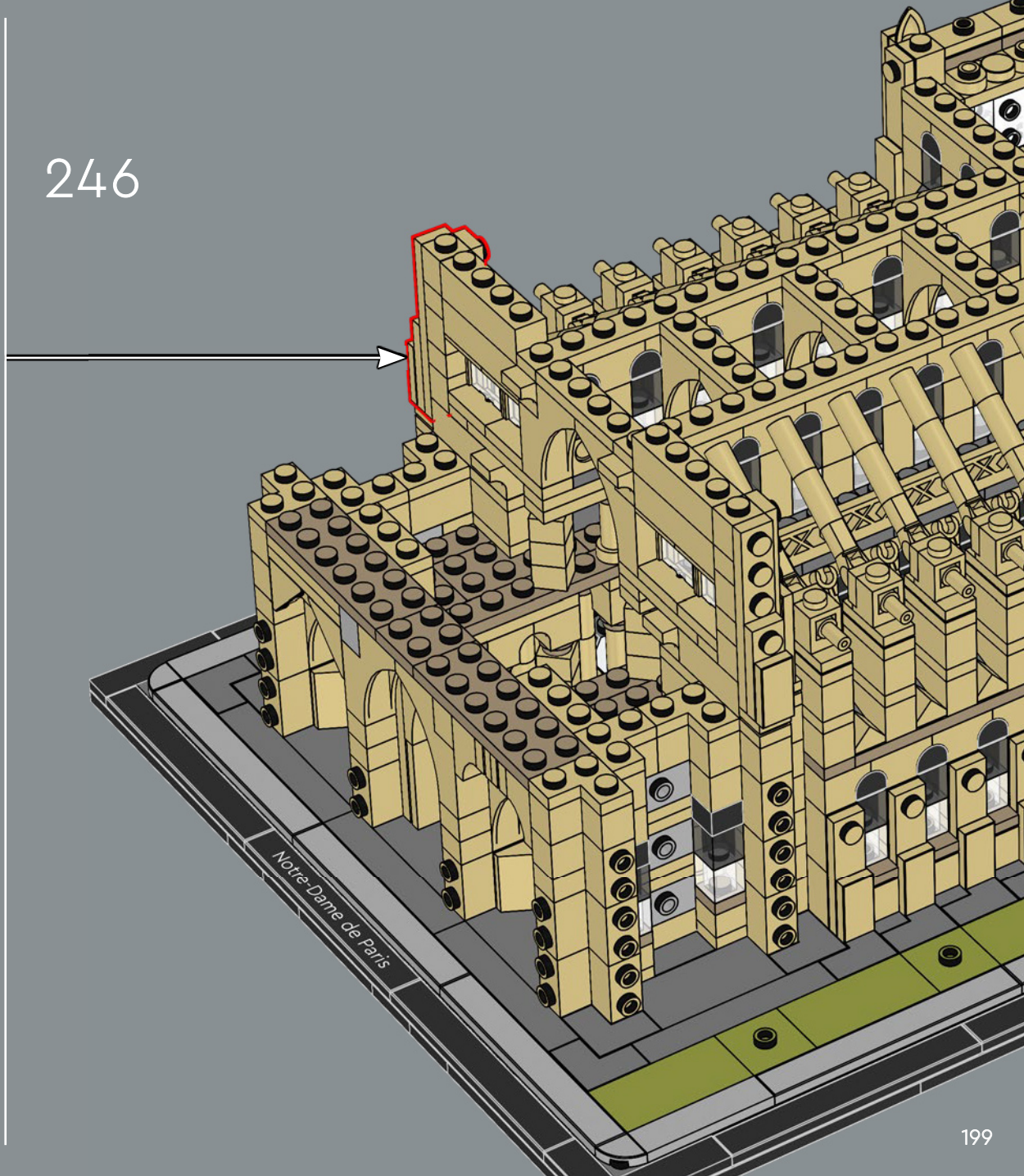



247

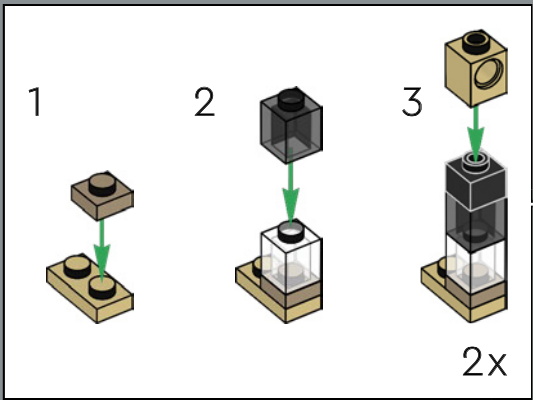

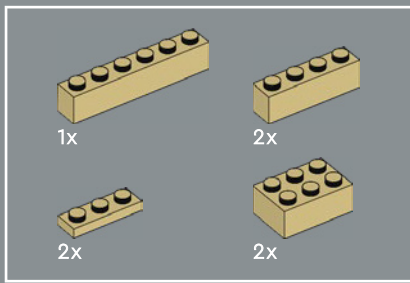

248

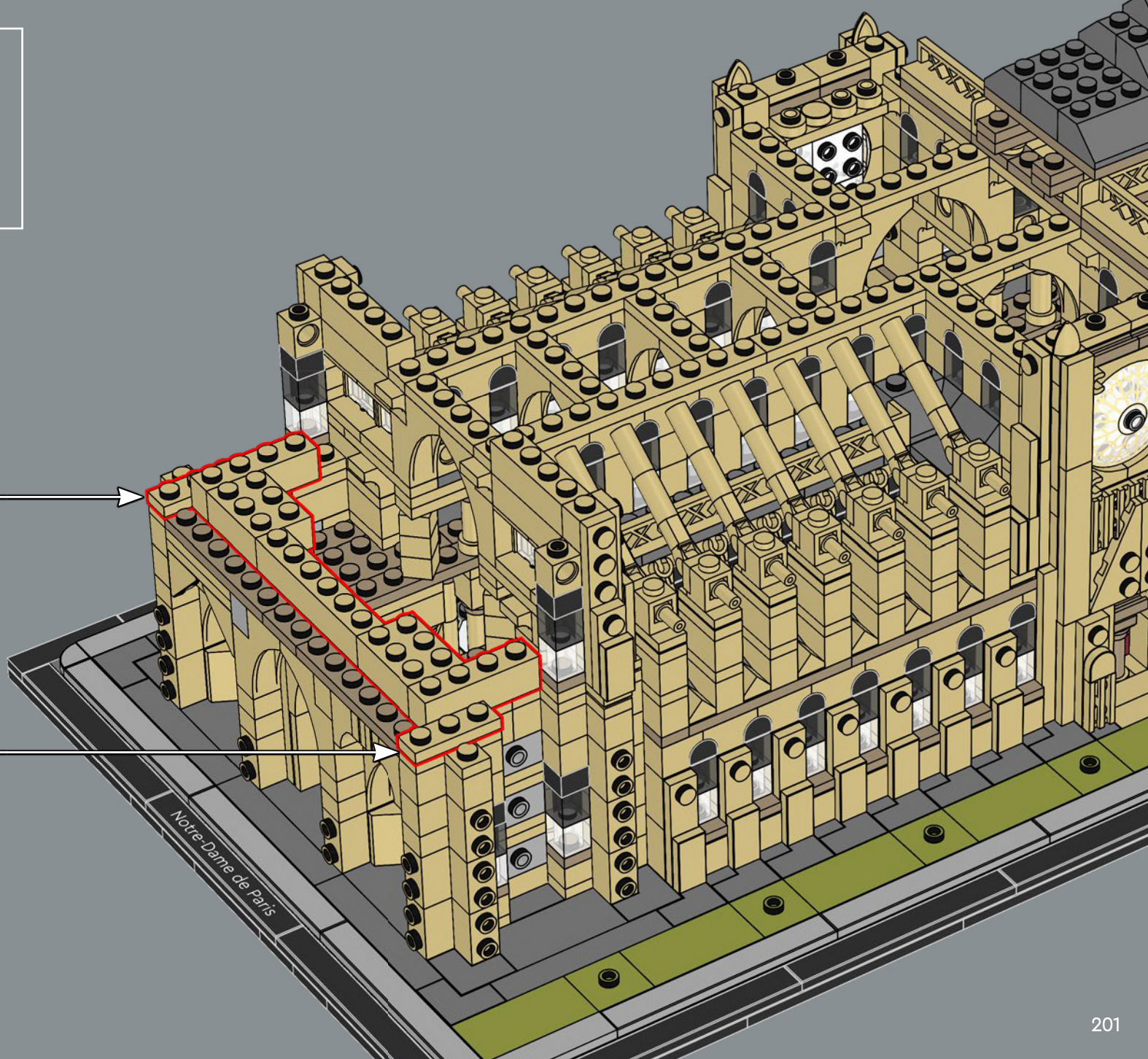
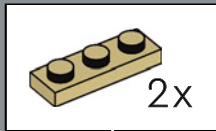

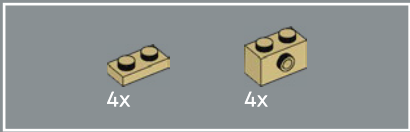

249

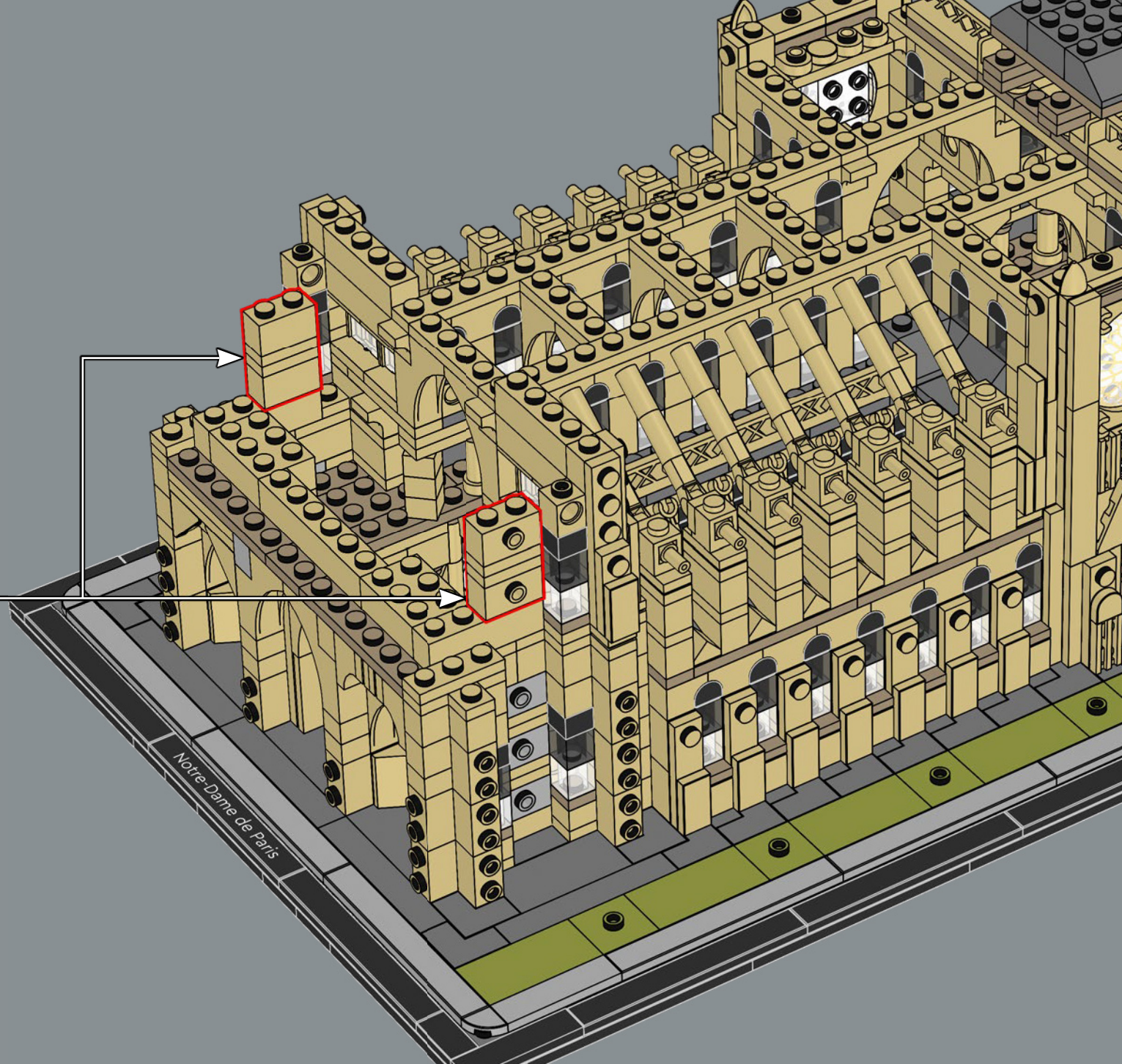
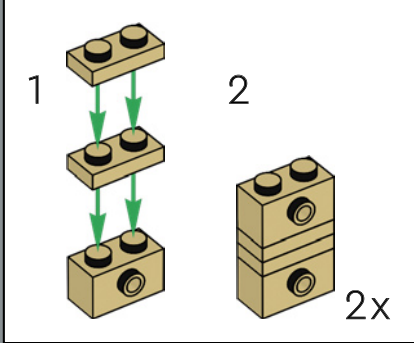

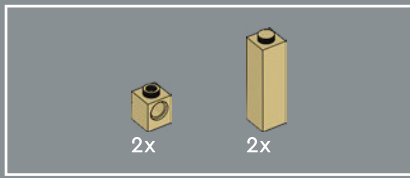

250

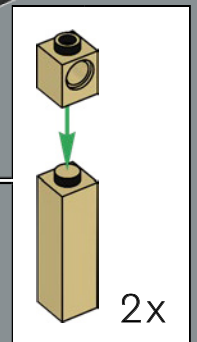
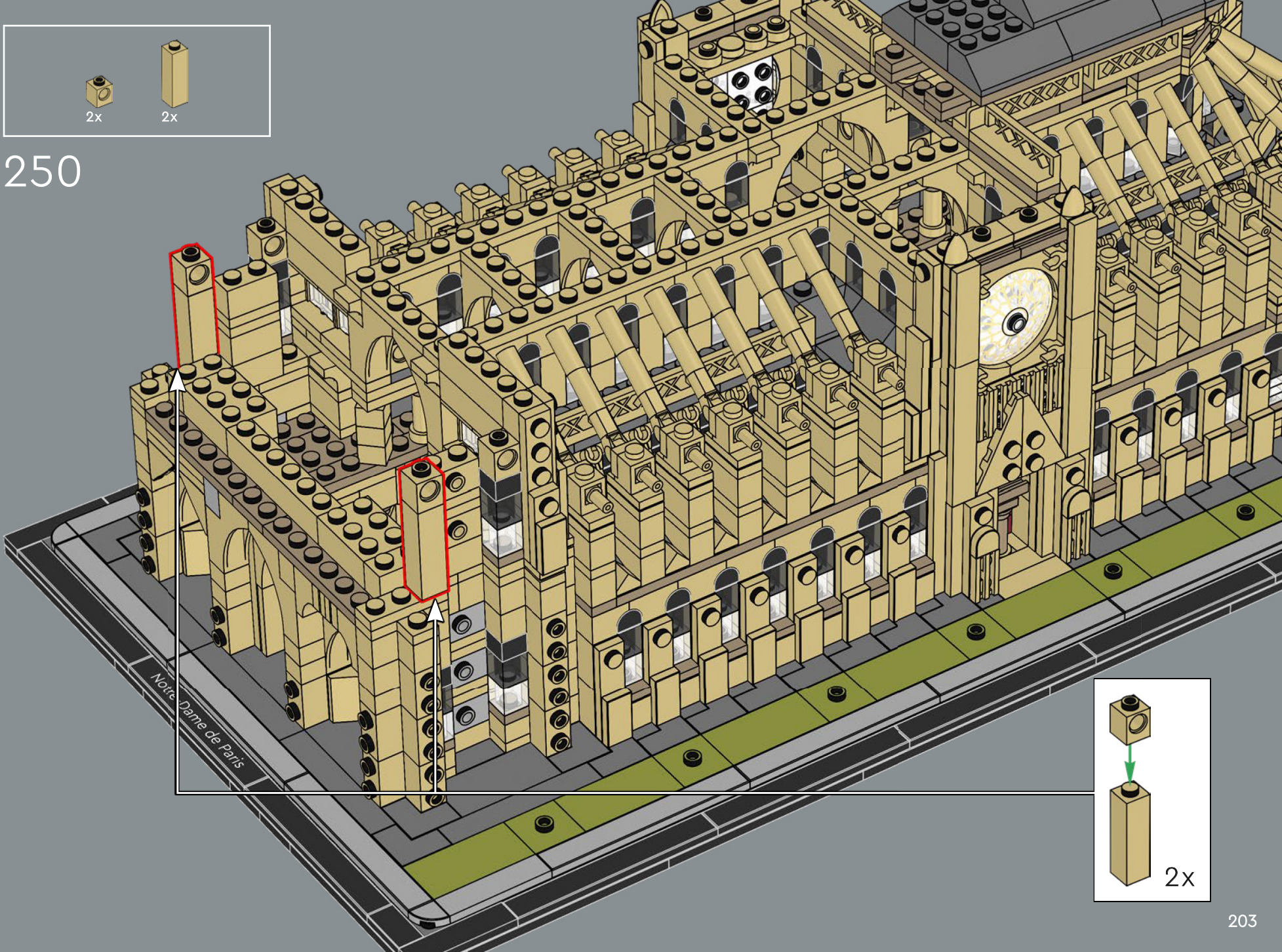

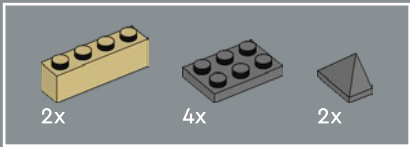

251

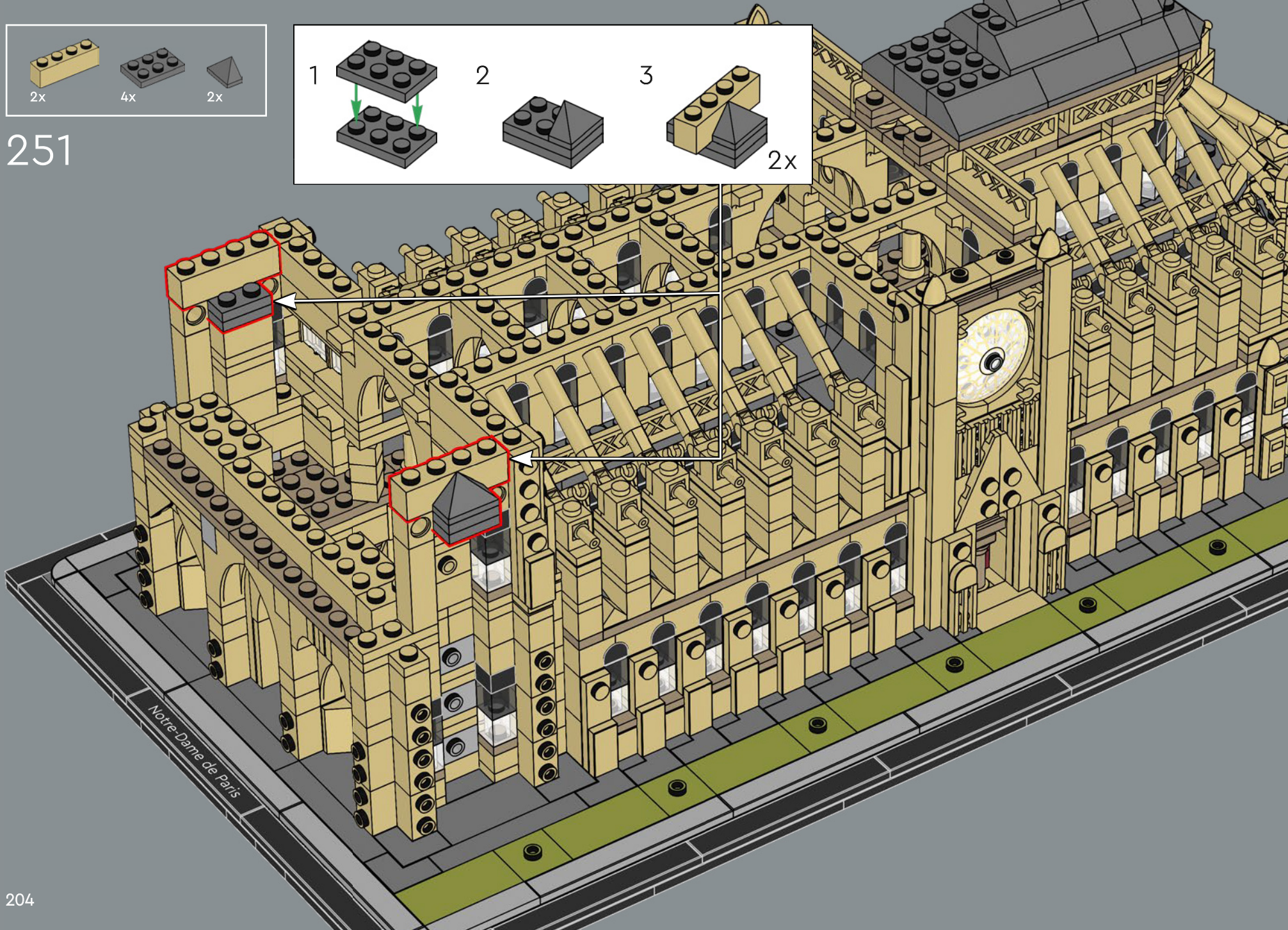
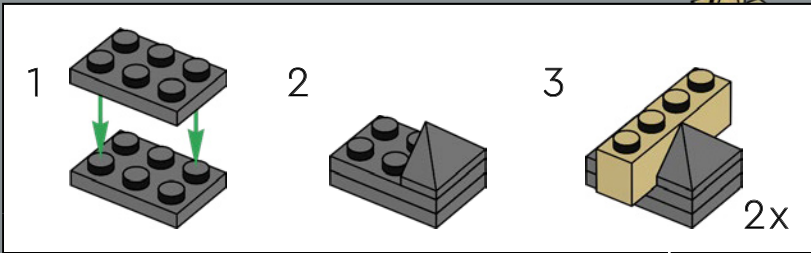

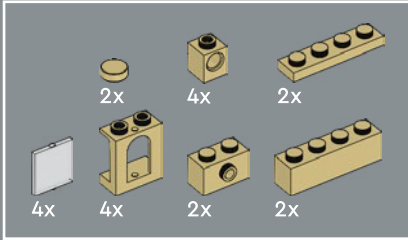
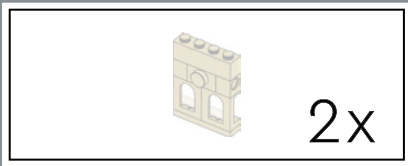

252

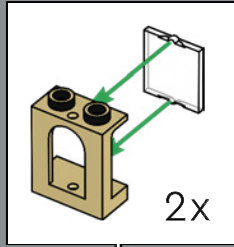

1

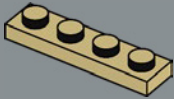

2

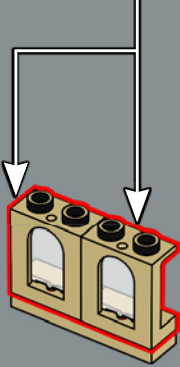

3

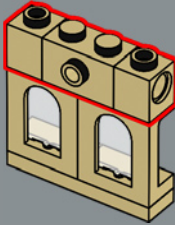

4

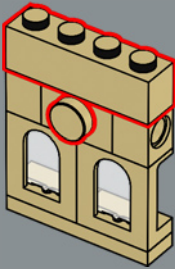

2x

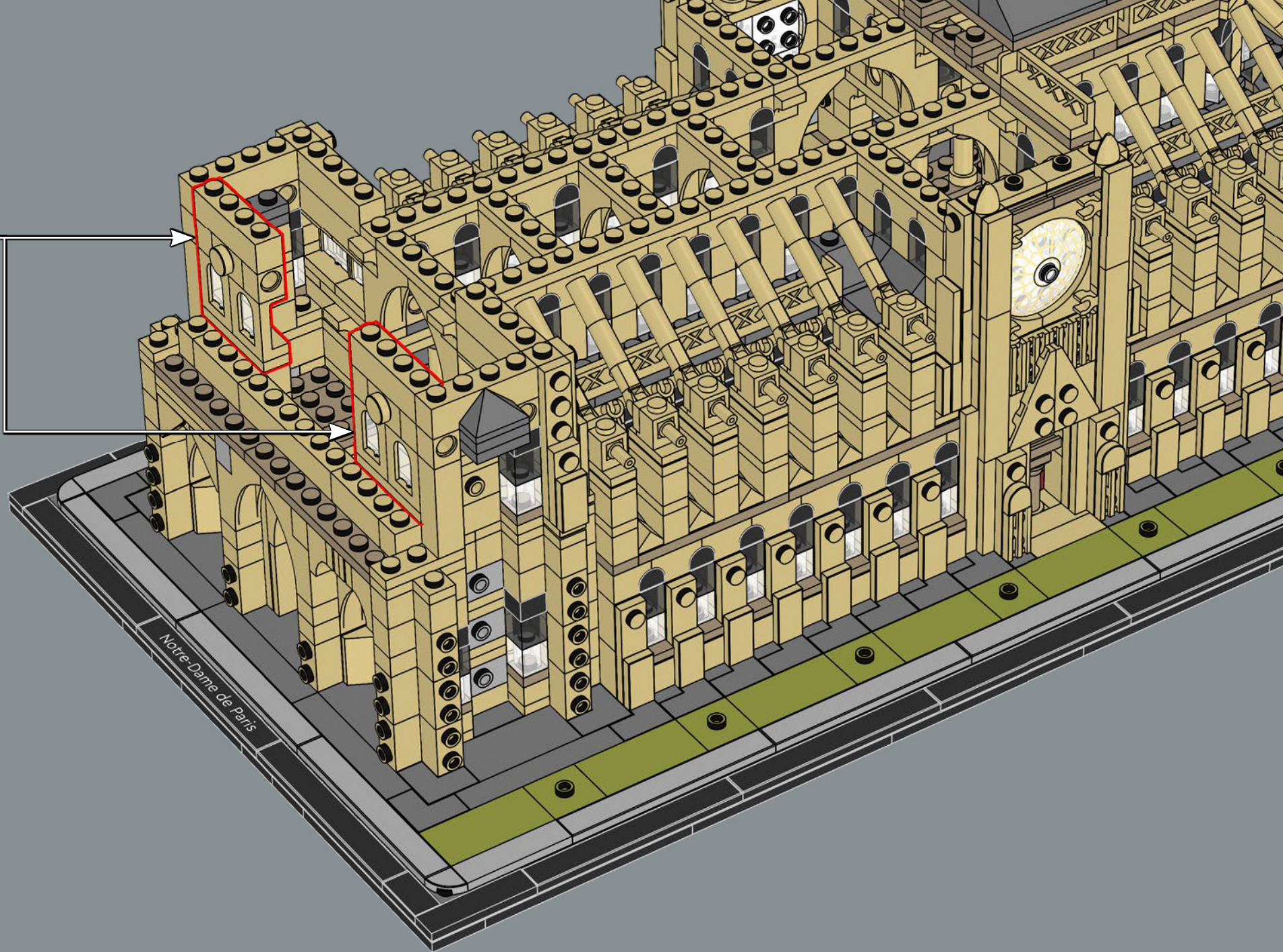

Notre-Dame de Paris

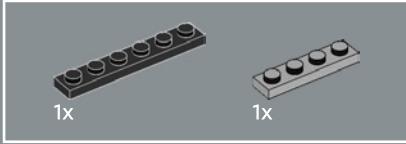
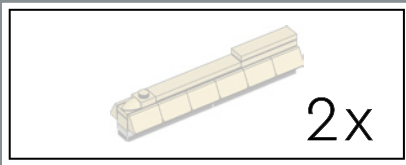

253

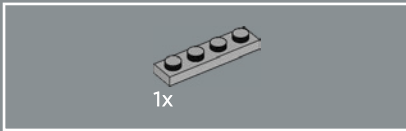
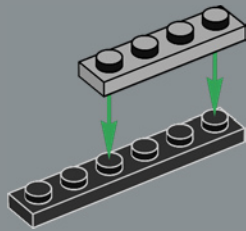

254

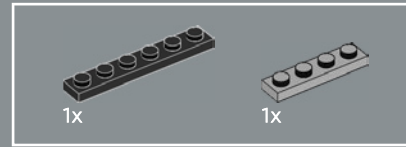
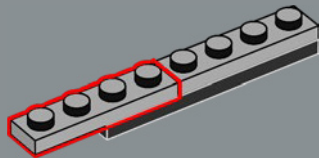

255

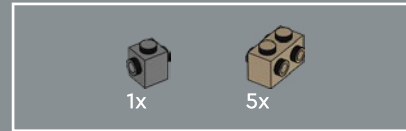
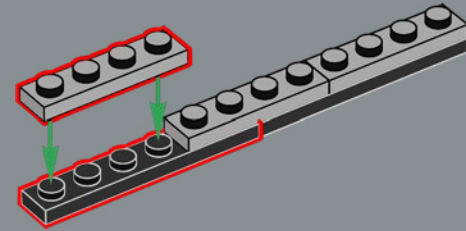

256

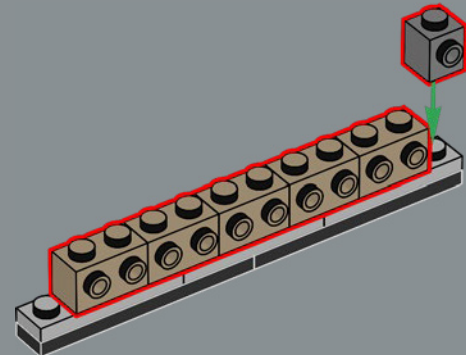

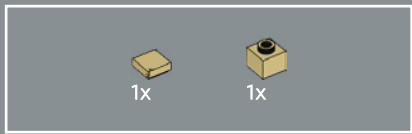

257

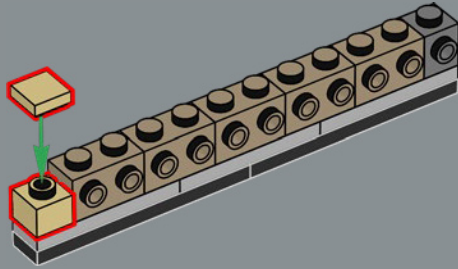

258

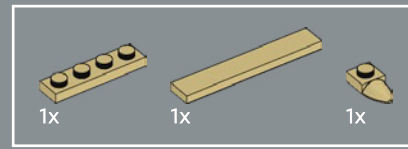
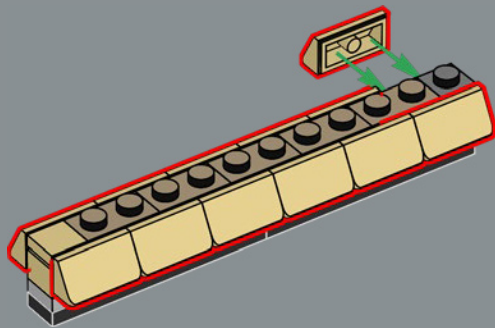

259

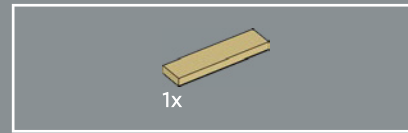
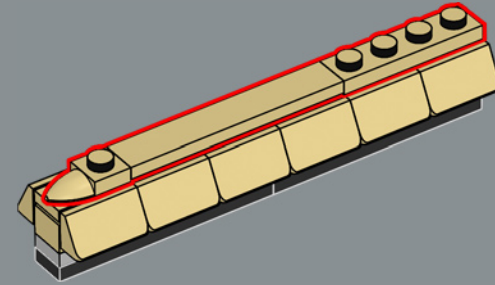

260

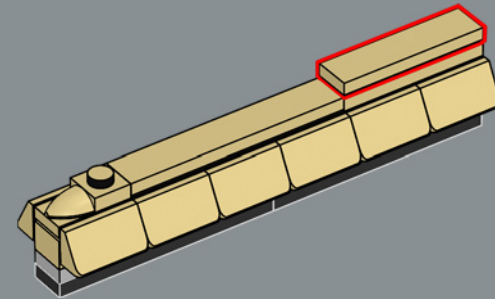

2x

261

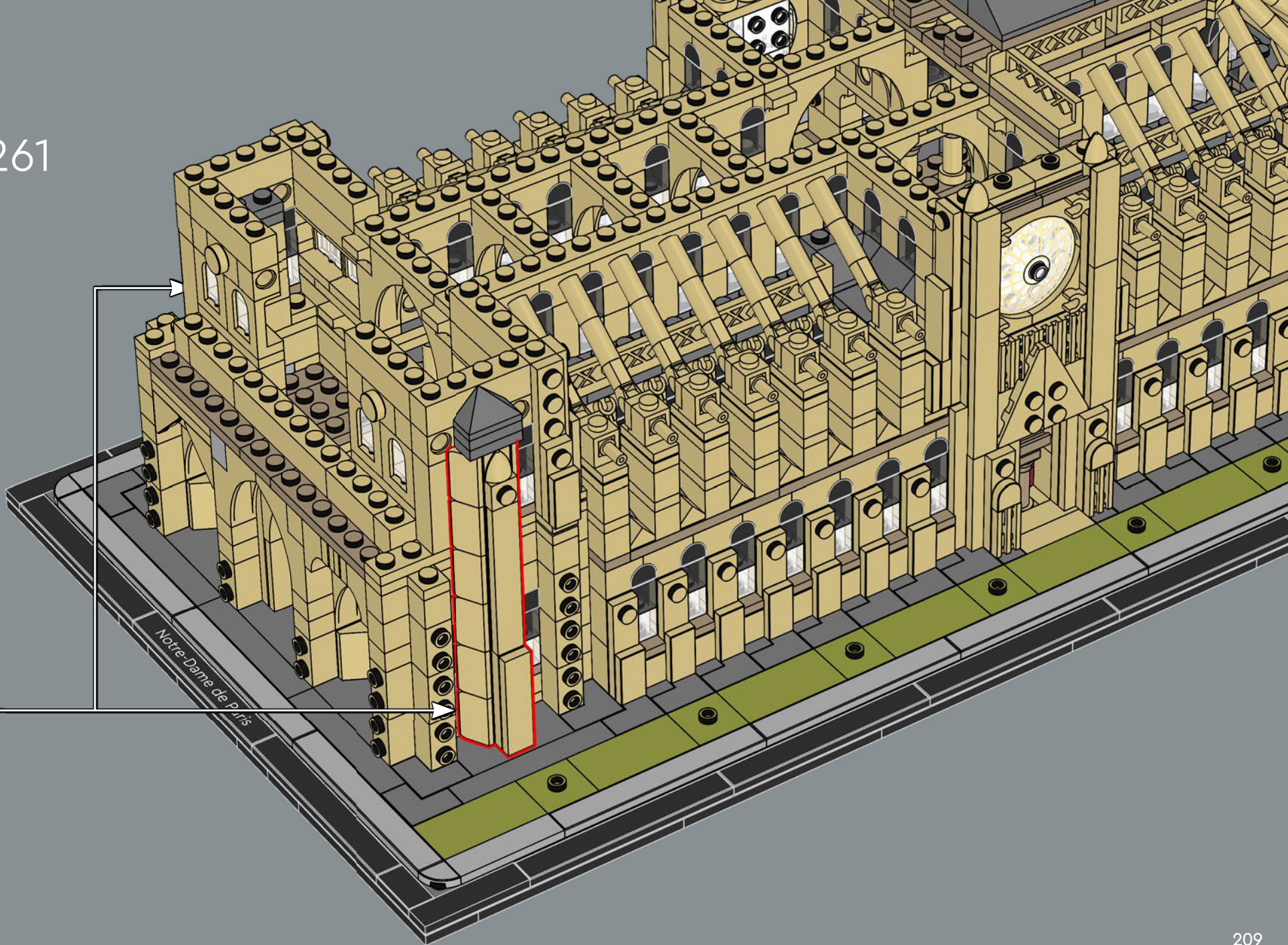

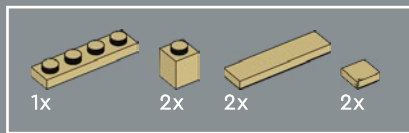

262

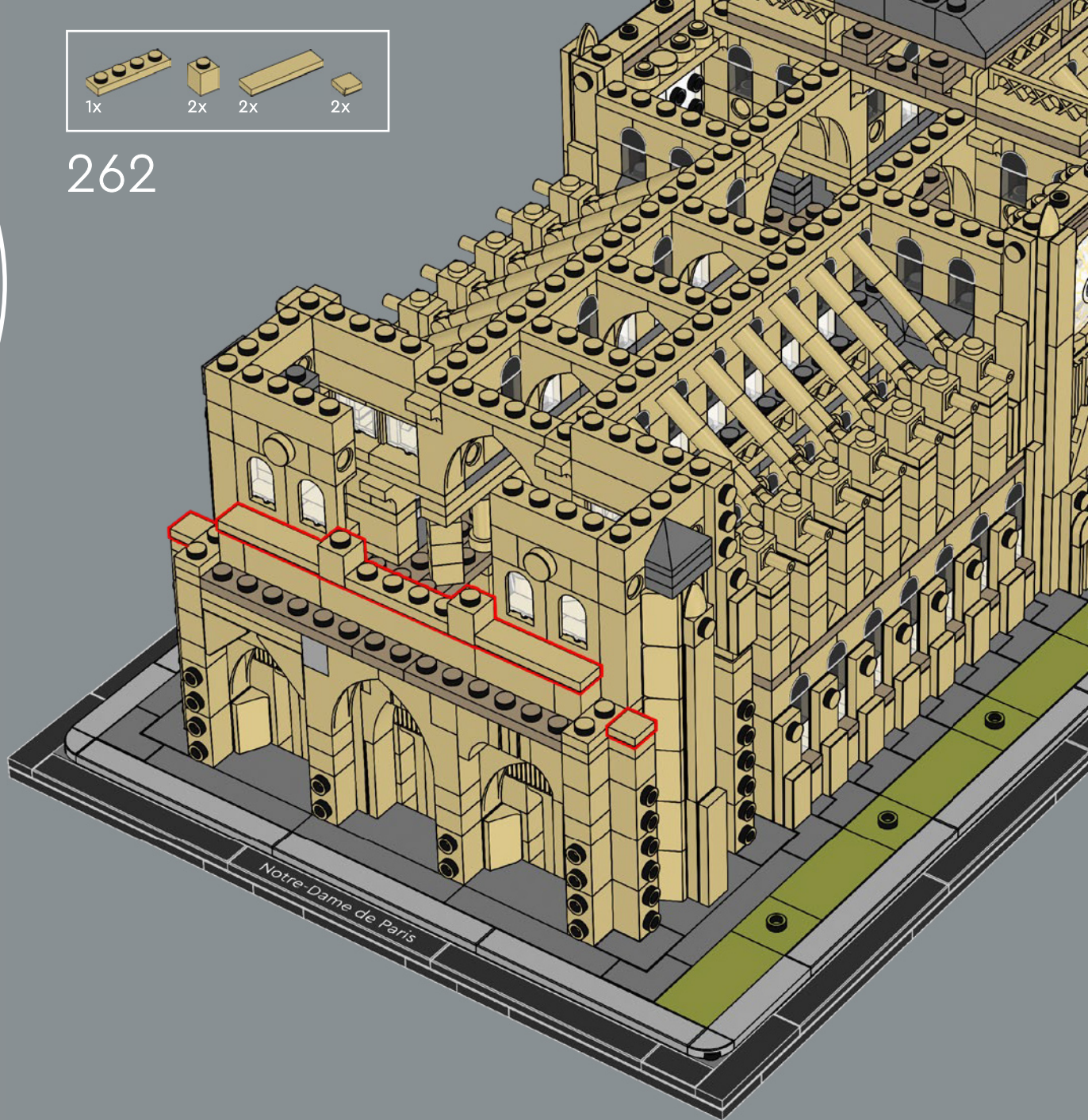



263



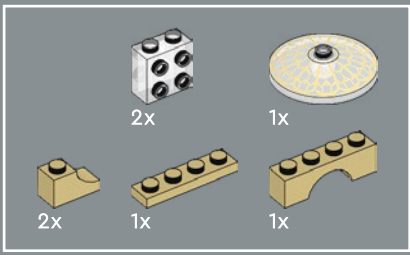

264

1

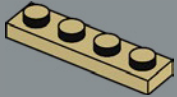

2

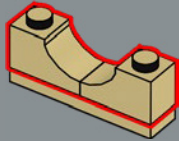

3

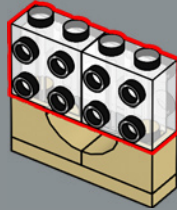

4

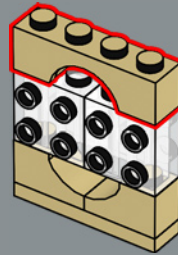

5



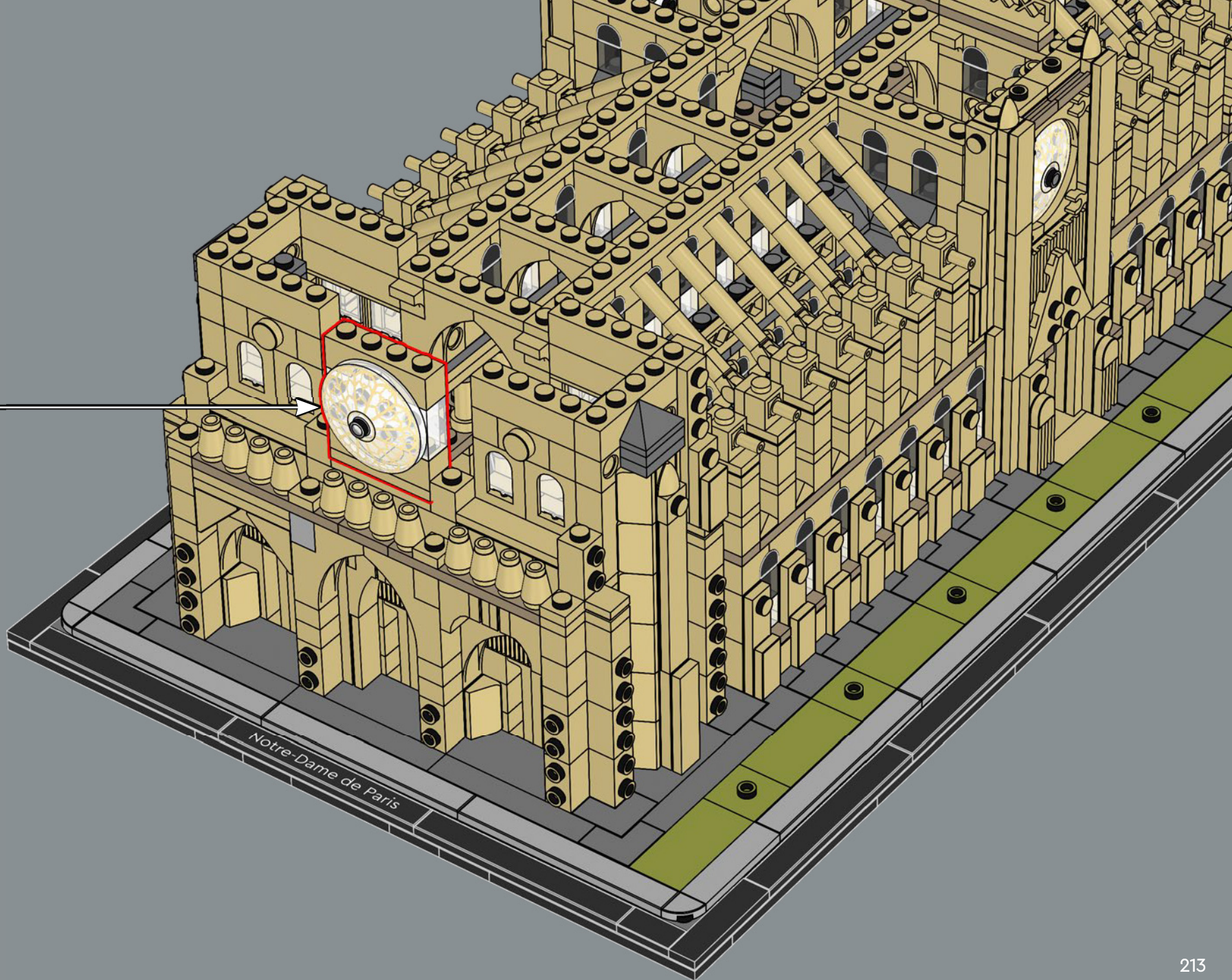

Notre-Dame de Paris

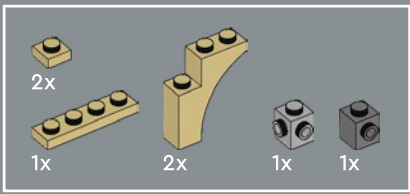

265

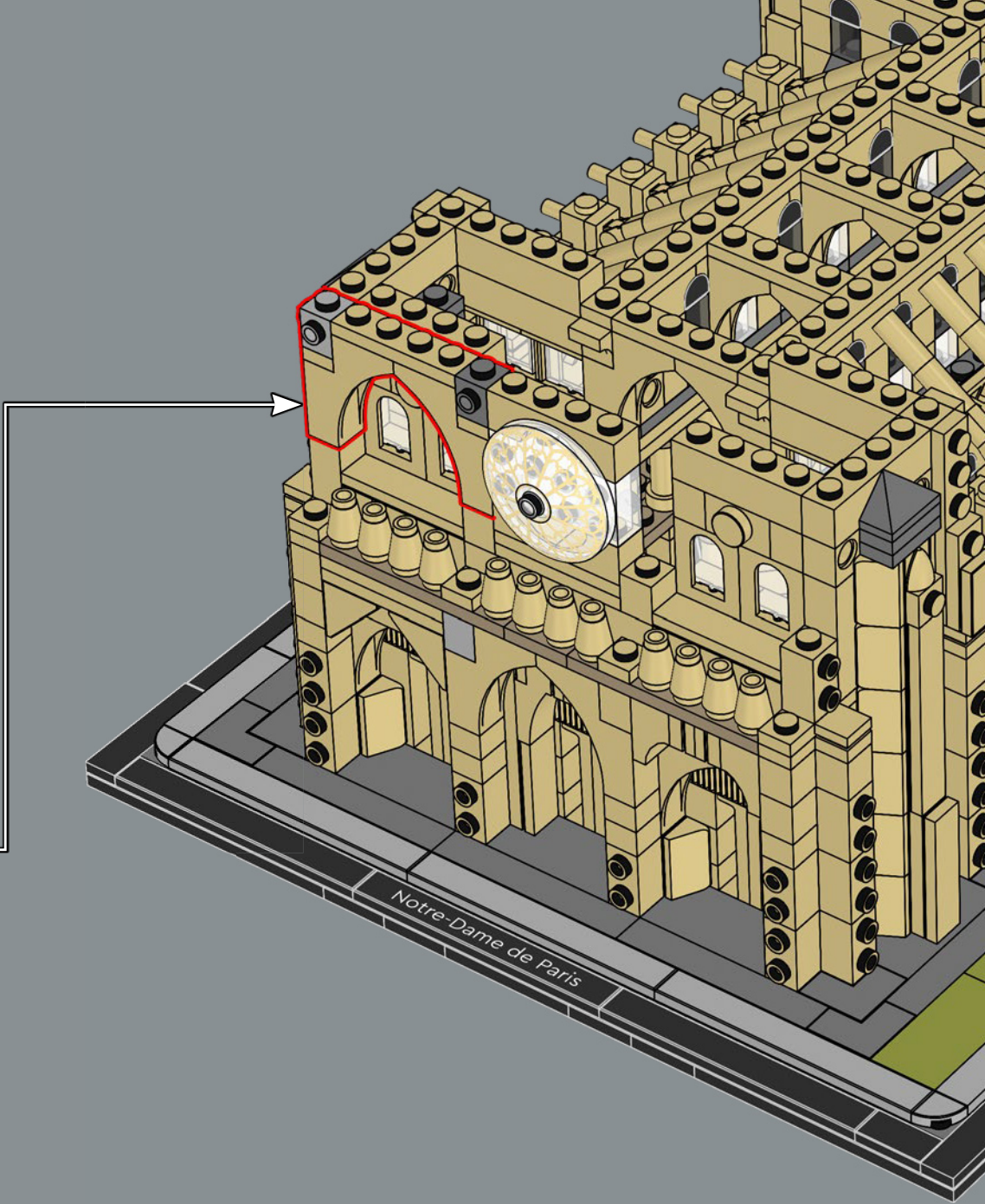
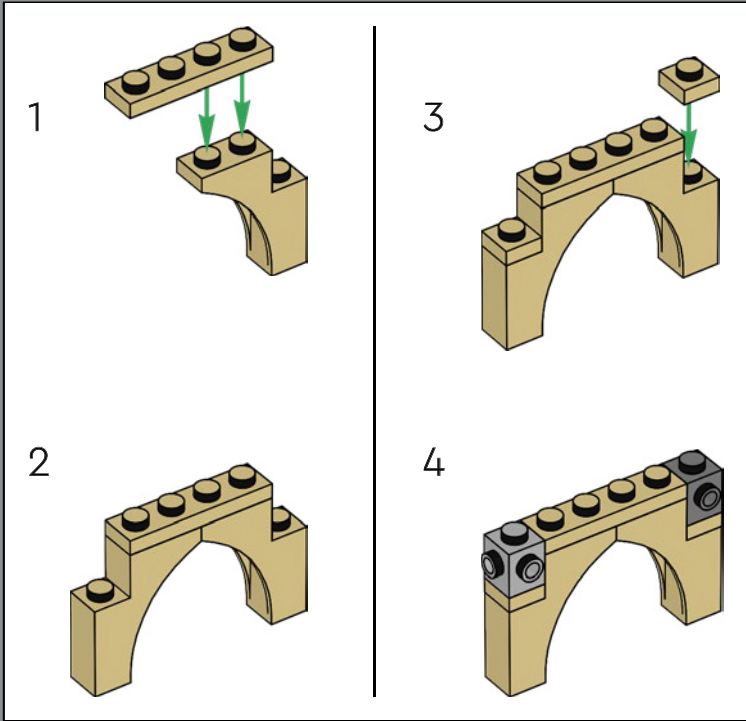

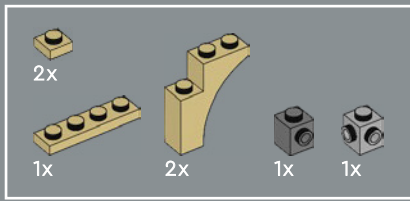

266

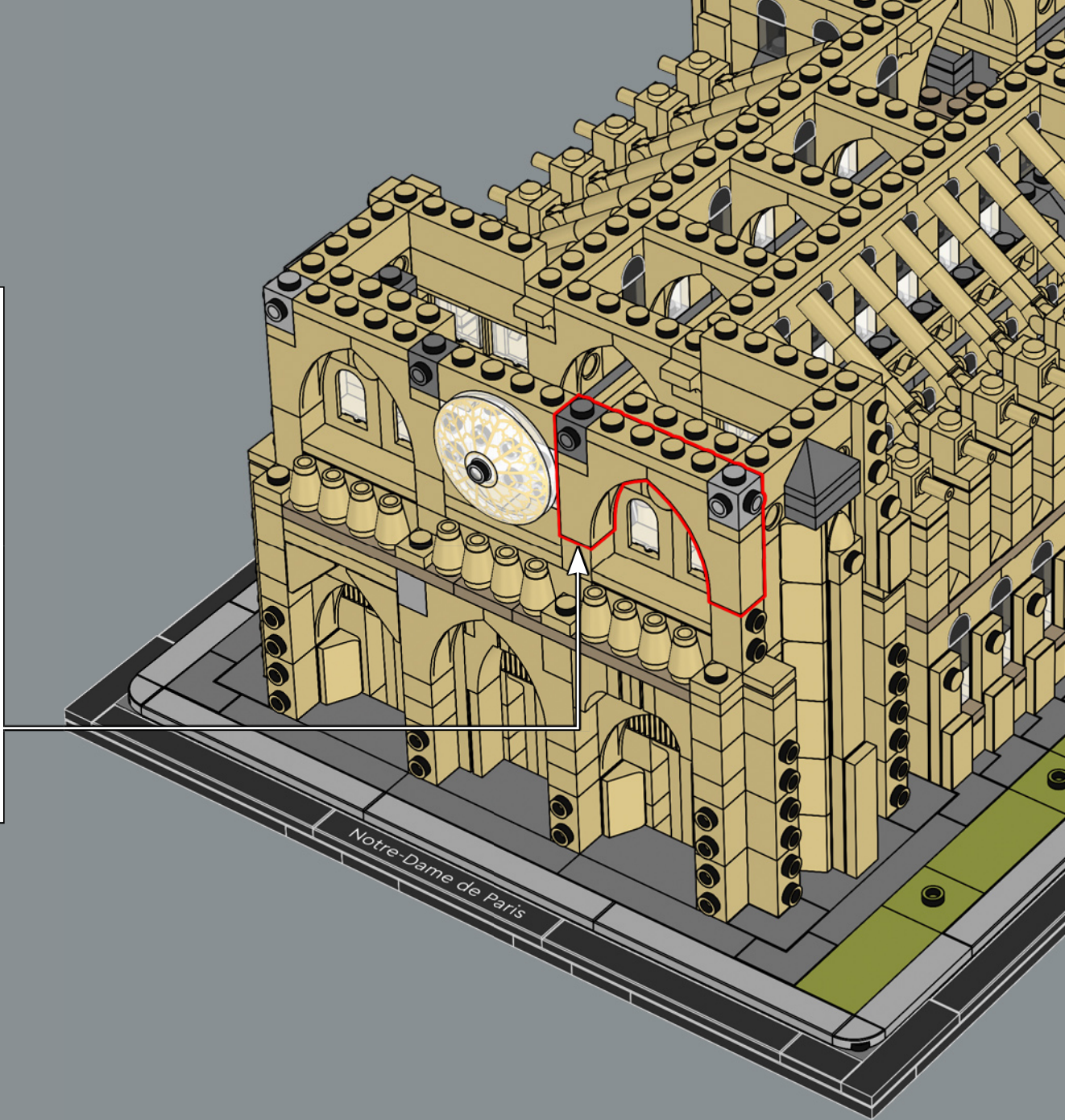
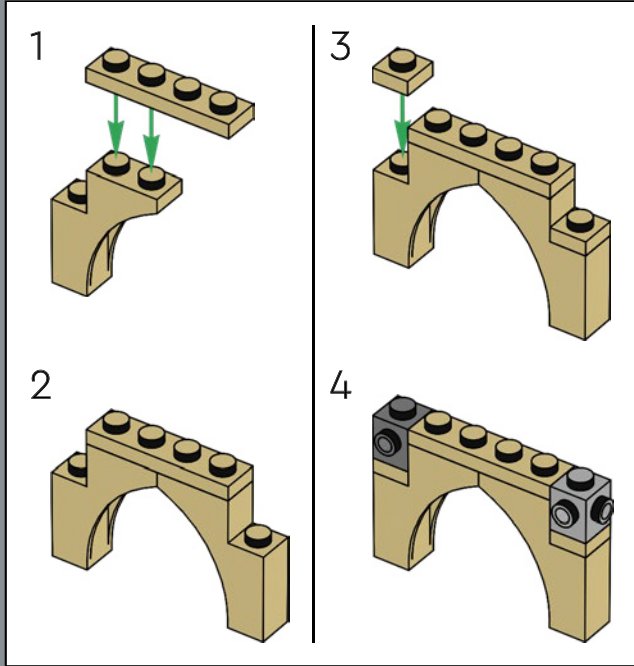

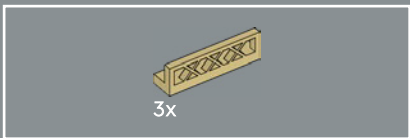

267

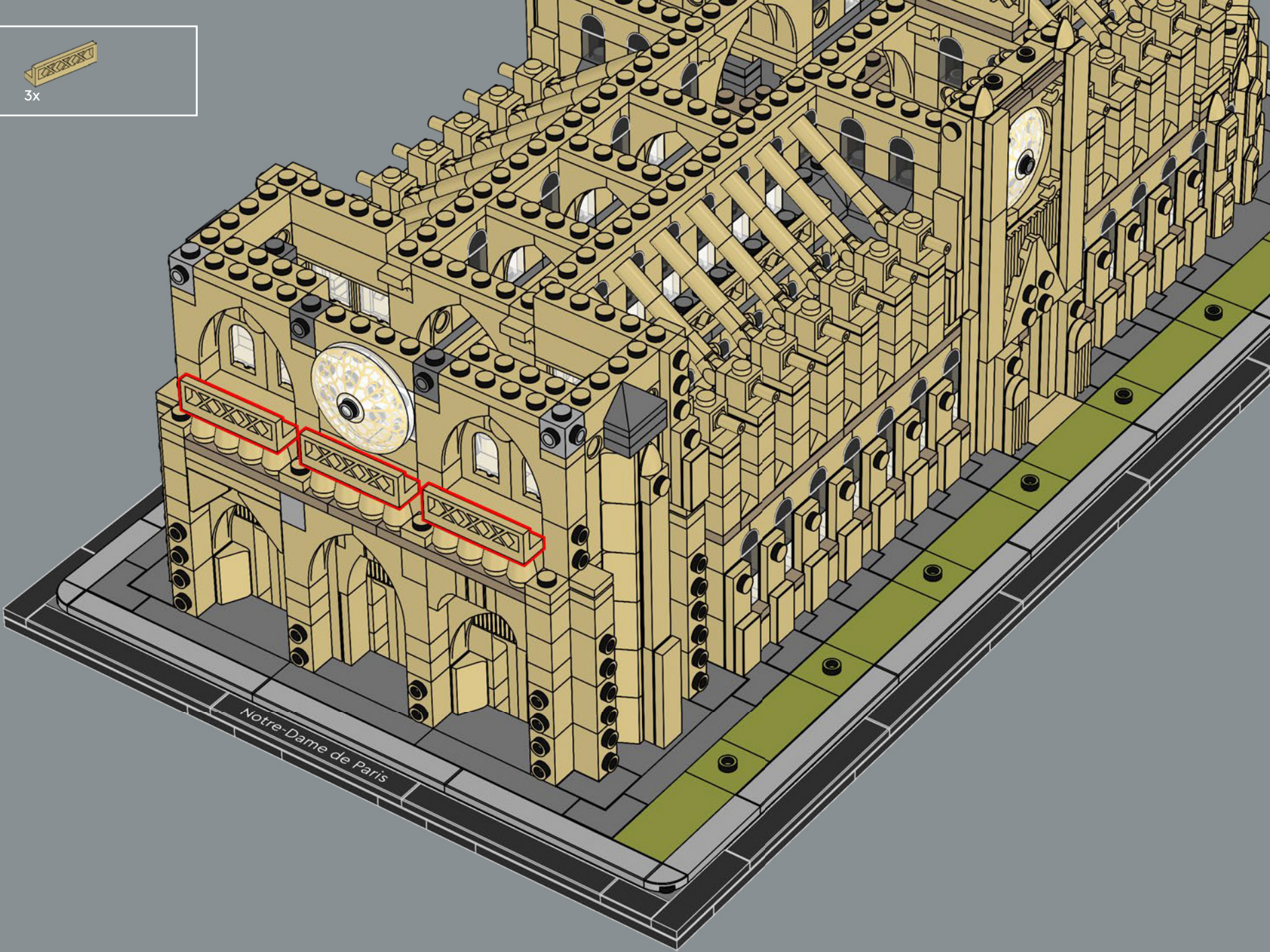

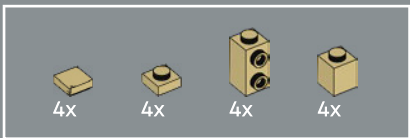

268

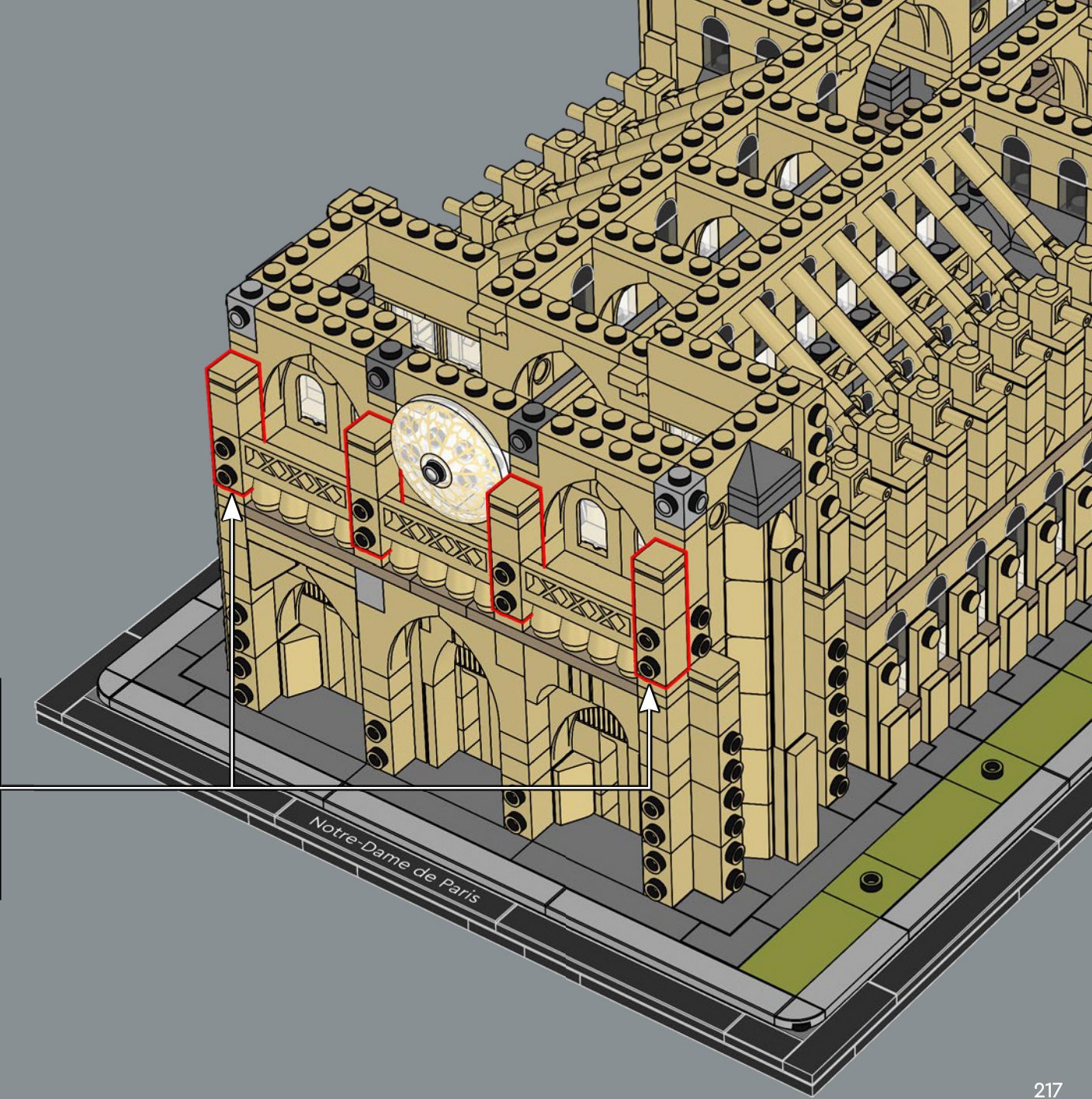
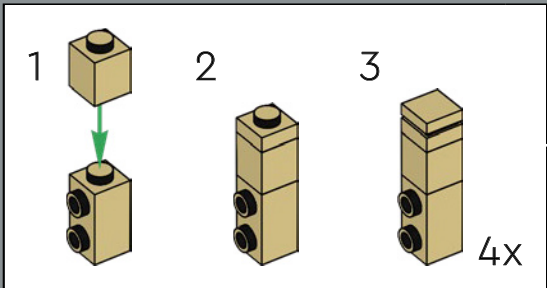

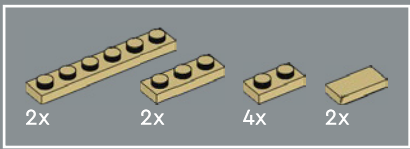

269

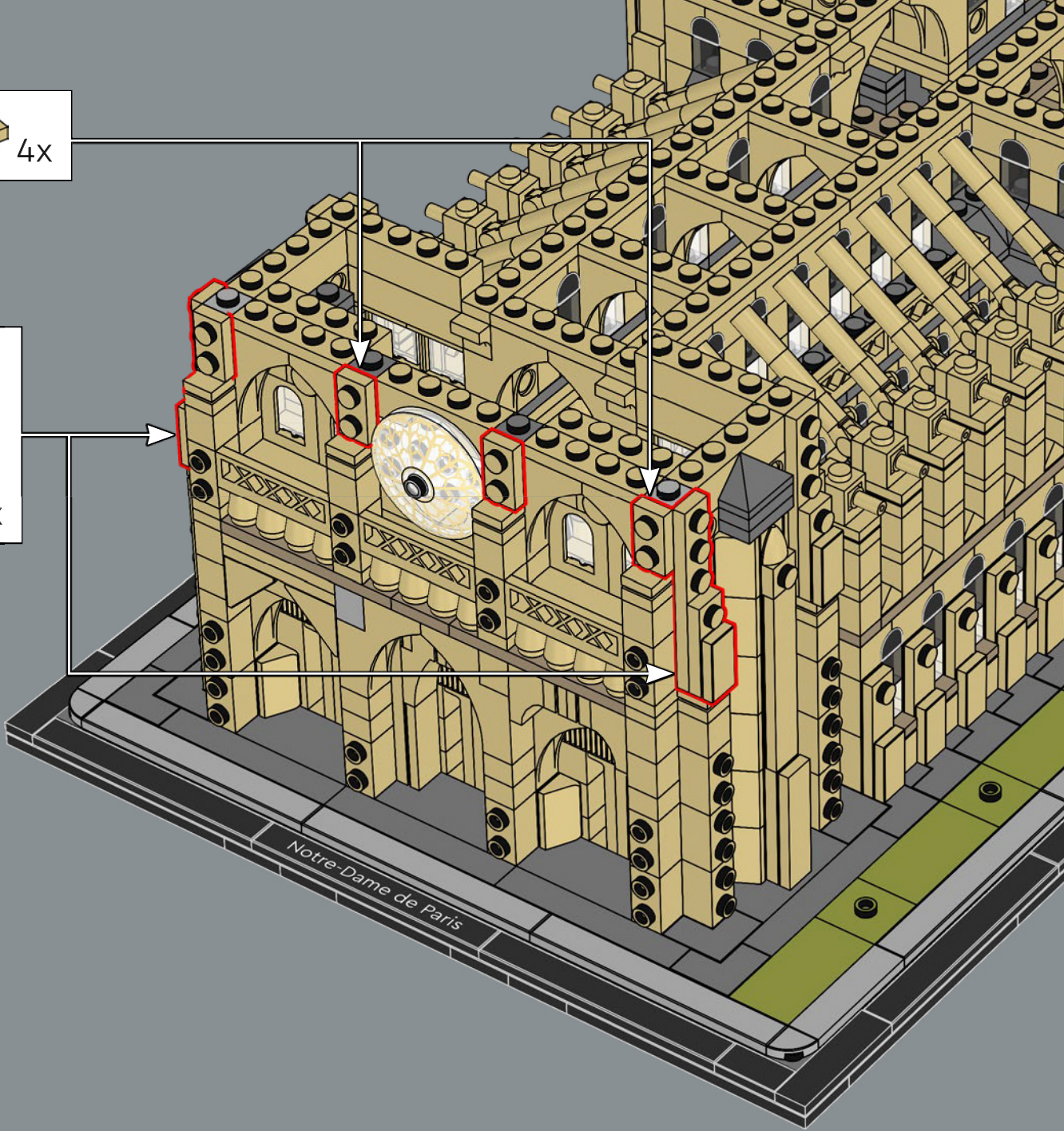
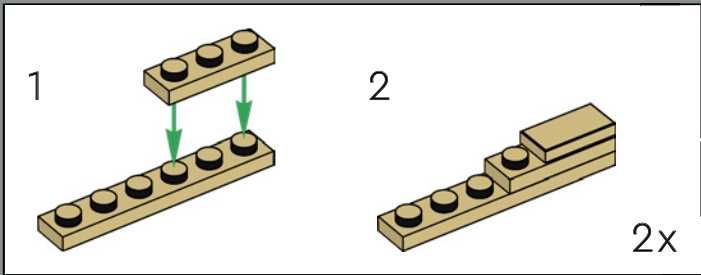
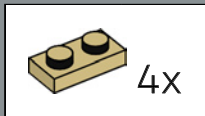

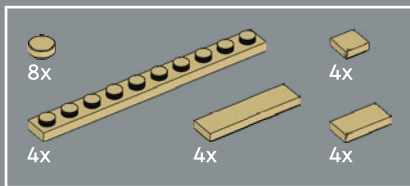

1220 年——在国王画廊的监视下，三个门户通过巴黎圣母院的庄严入口欢迎游客。28 个巨大的雕像由 20 个乐高®圆锥体和圆形组件展现。

270

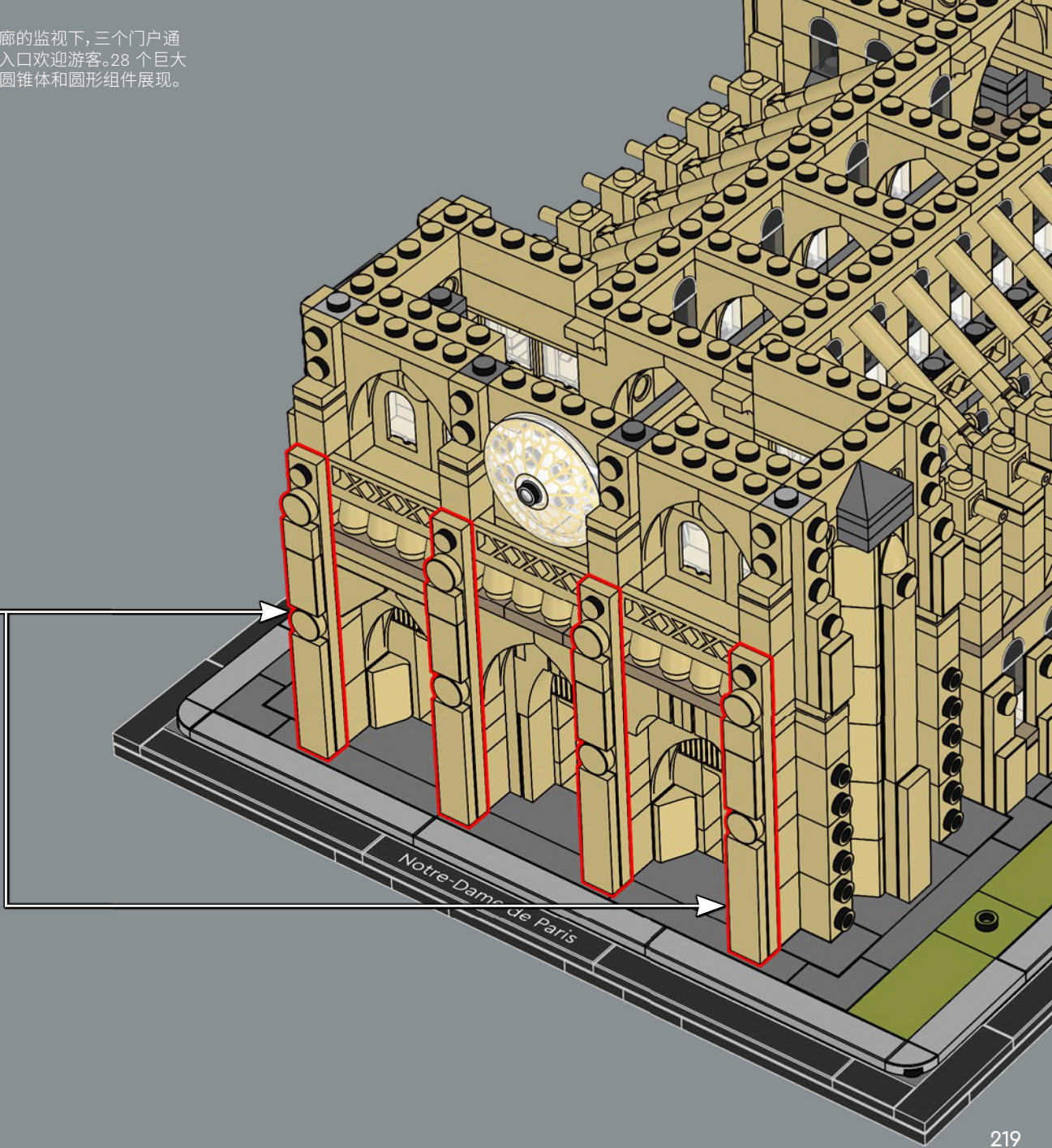
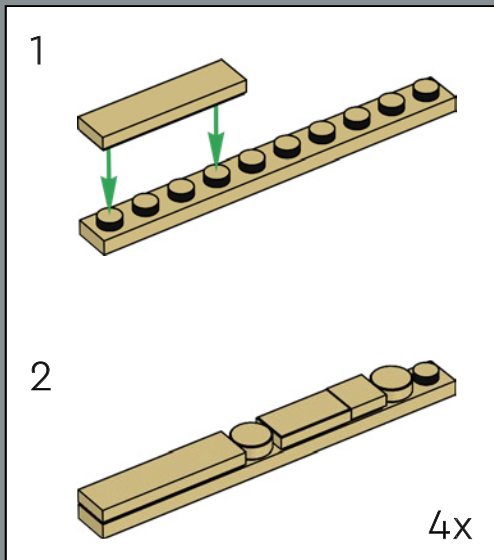

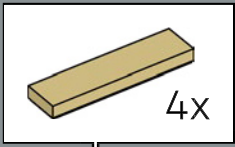
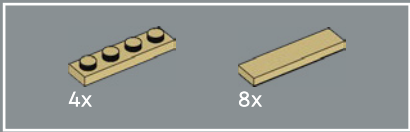

271

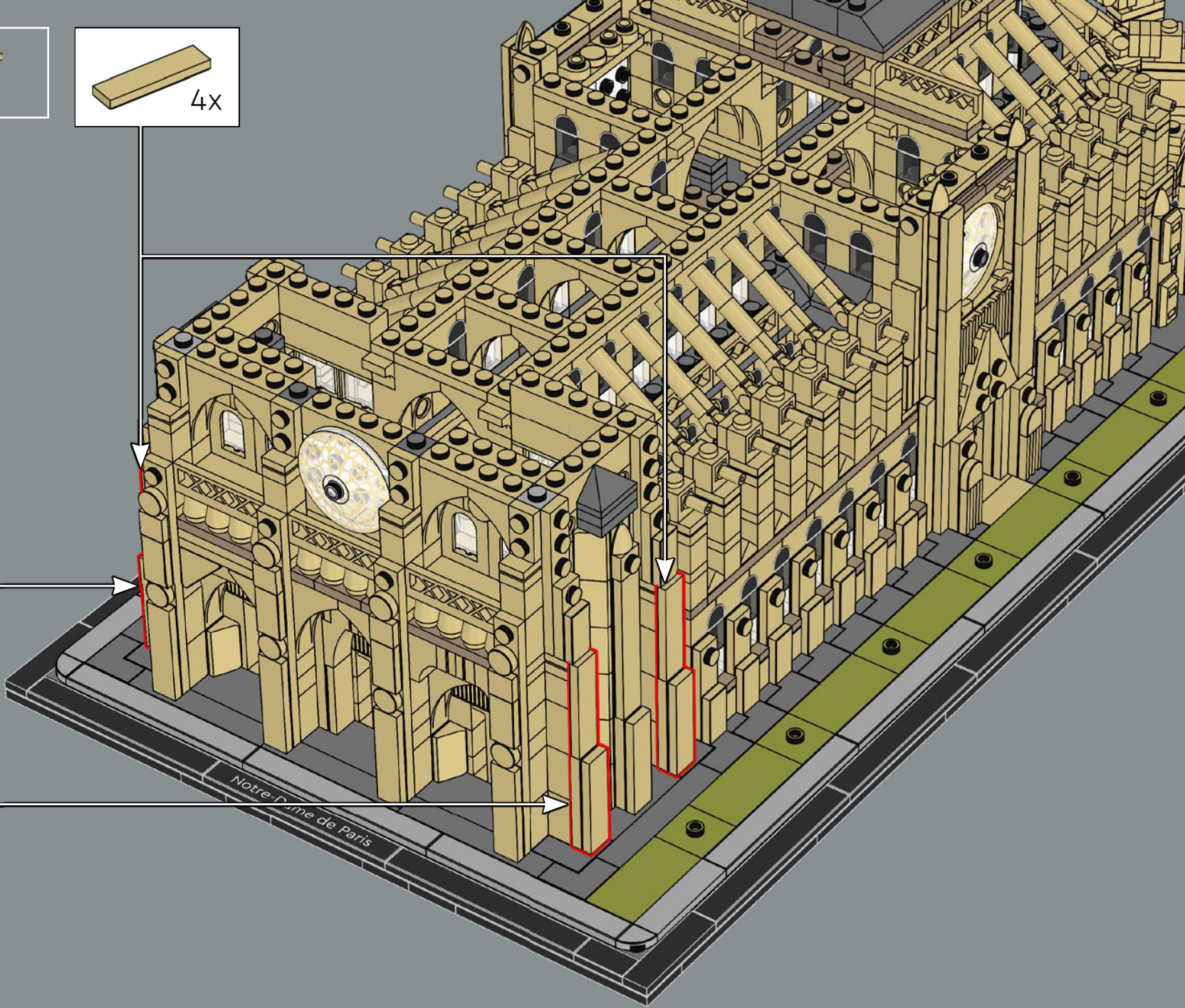
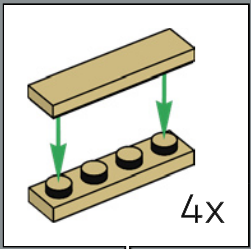

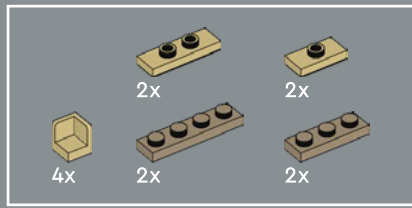

272

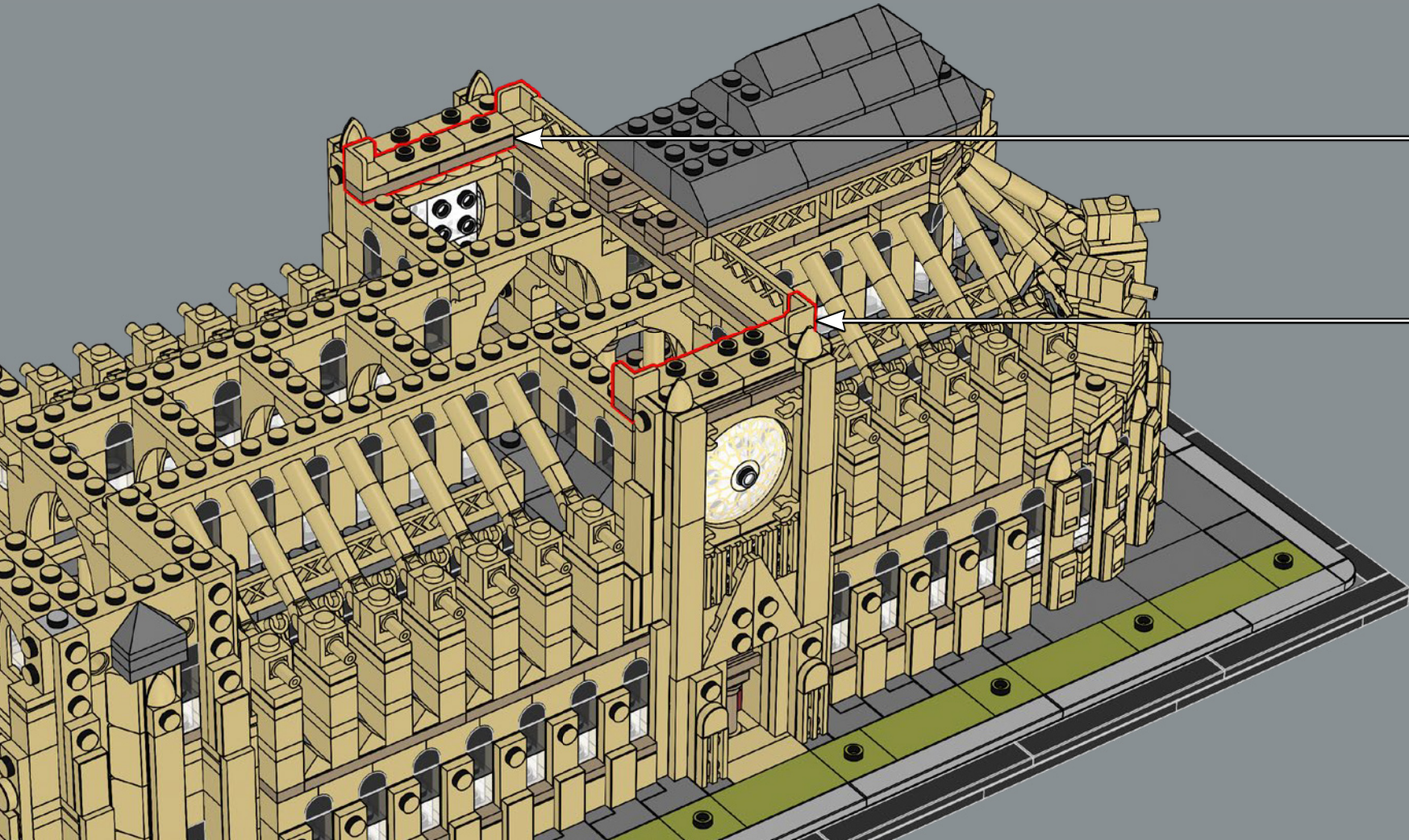
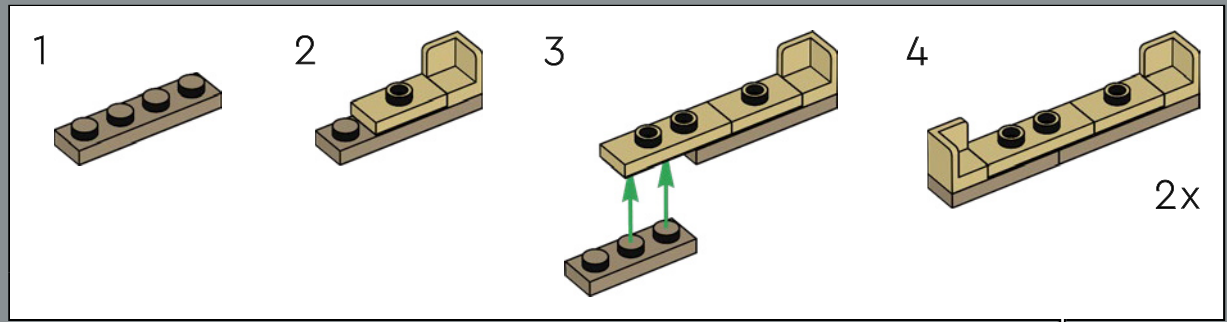

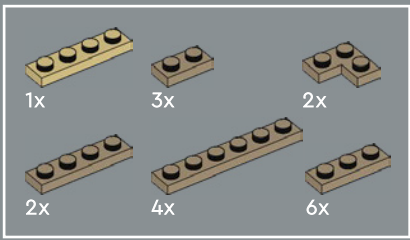

273

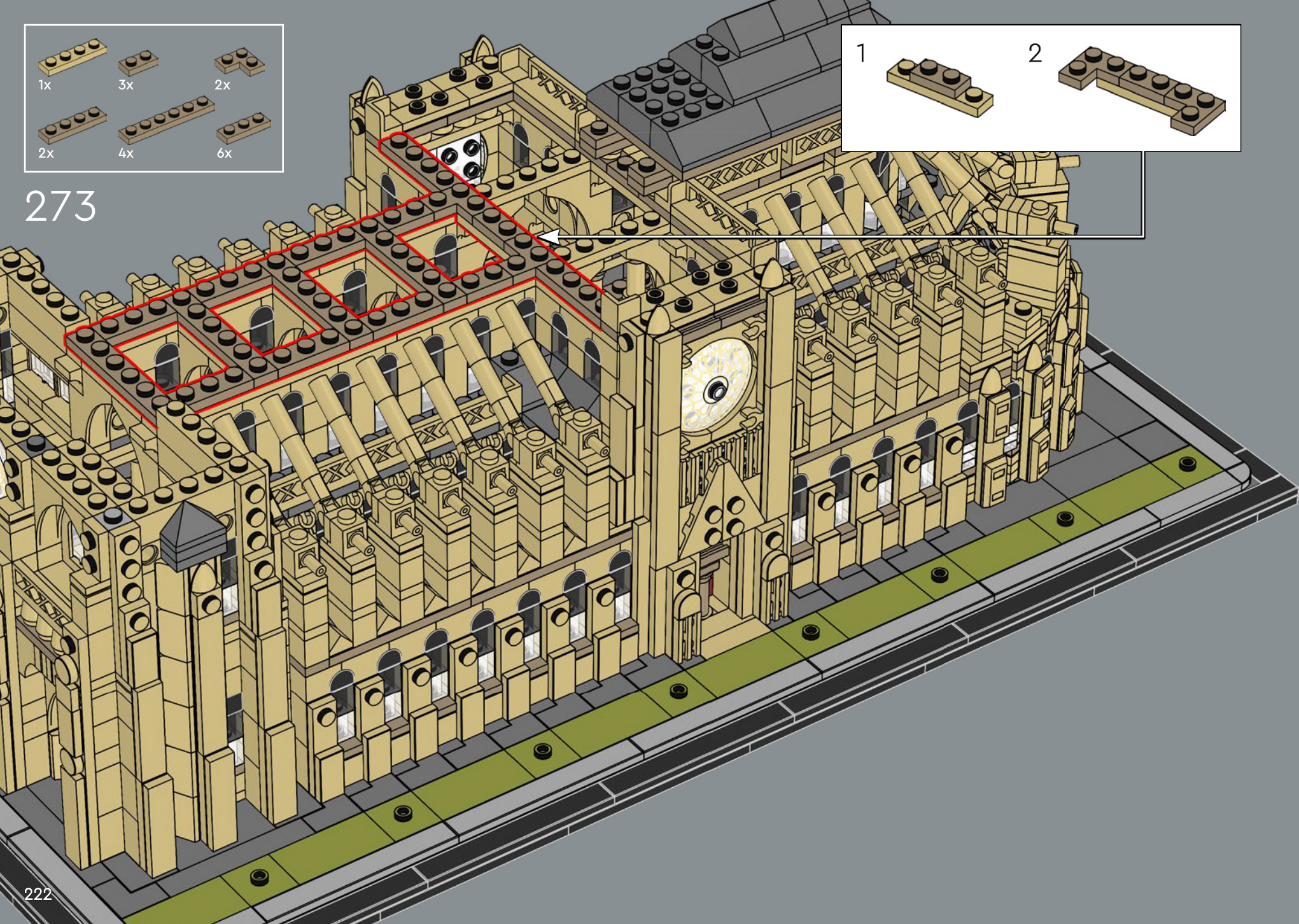
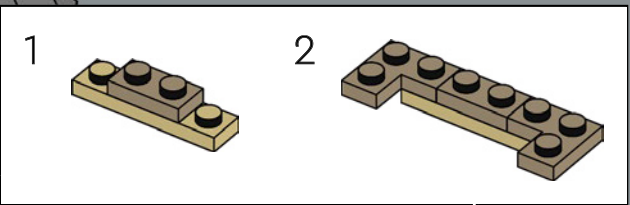

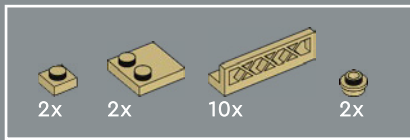

274

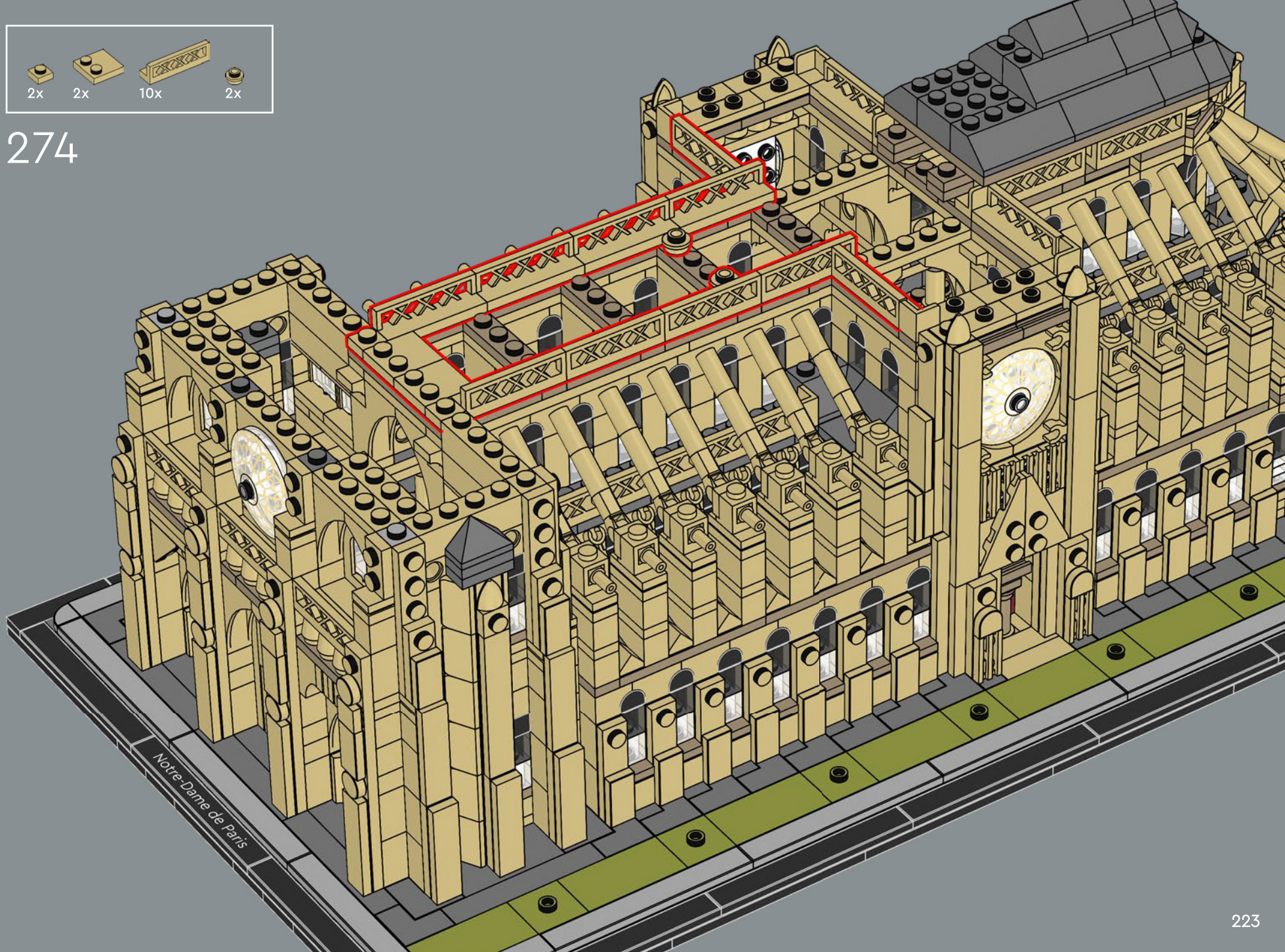



改造仍在继续

🌀 1245年，所有塔楼完工。当你拼搭这些塔楼时，可以了解巴黎圣母院钟楼的一些内部结构以及支撑传奇大钟的上部结构。在接下来的五个世纪里，这座建筑开始损耗。新一代建筑师负责监督改造、维修和增建，比如在十字上方建造一座铅板覆盖的木质尖塔。1300年，在合唱堂周边添加了小教堂。



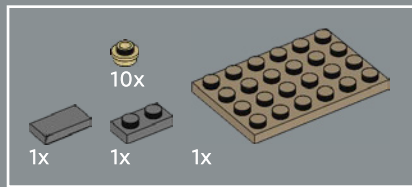

275

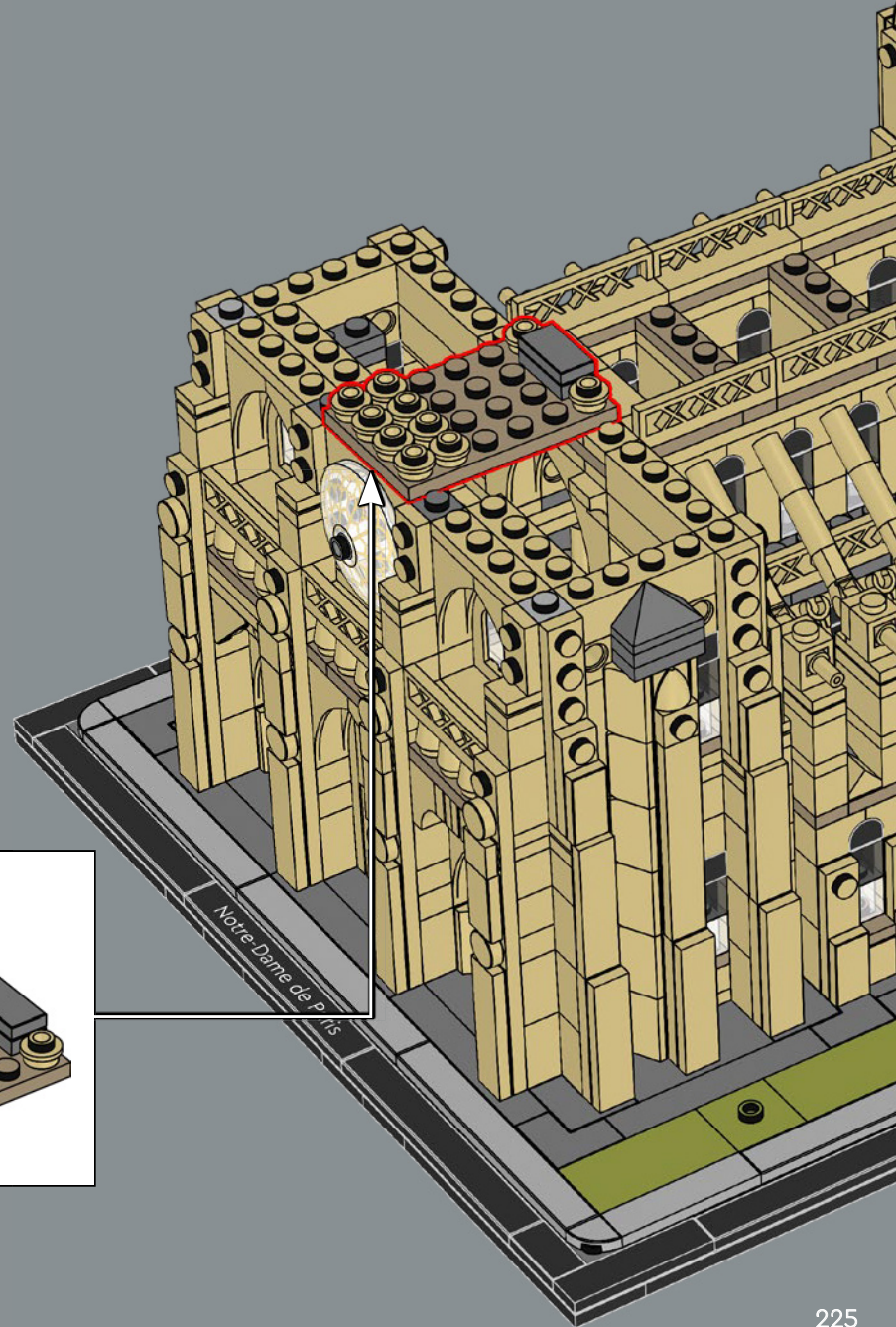
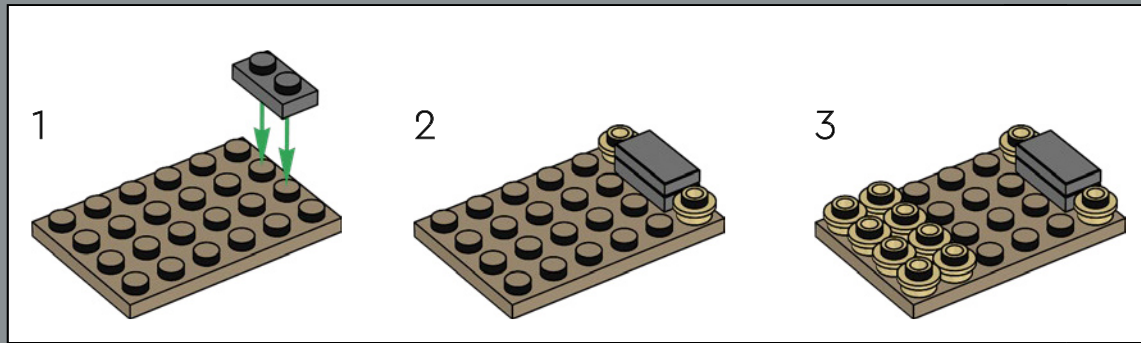

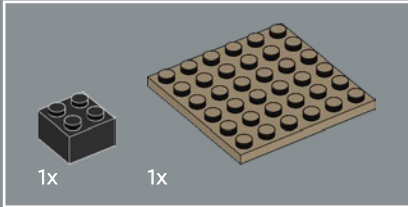
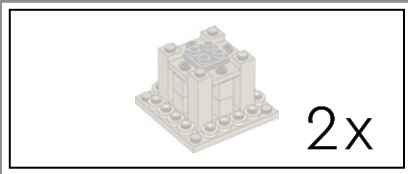

276

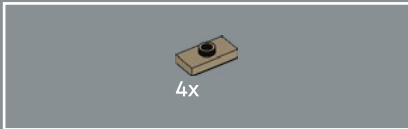
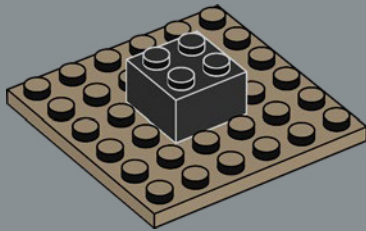

277

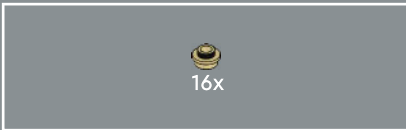
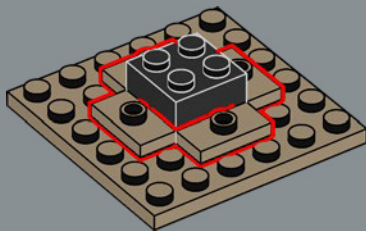

278

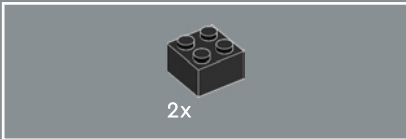
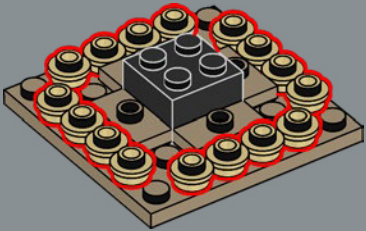

279

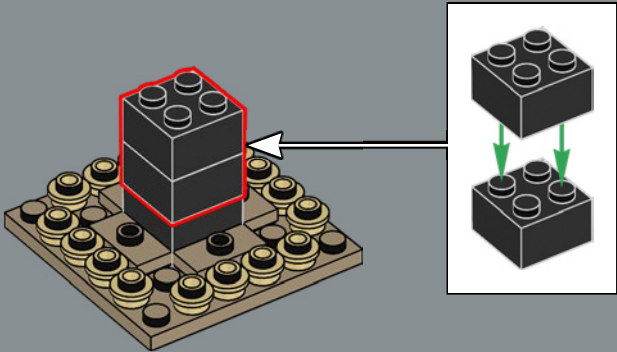



280

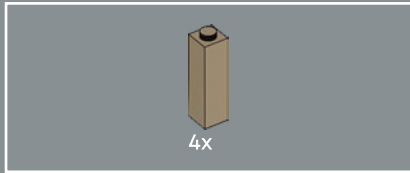
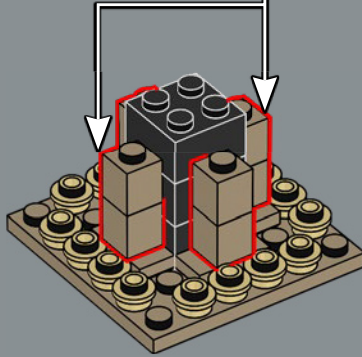
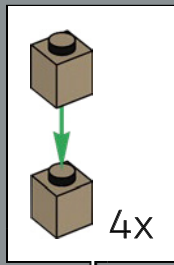

281

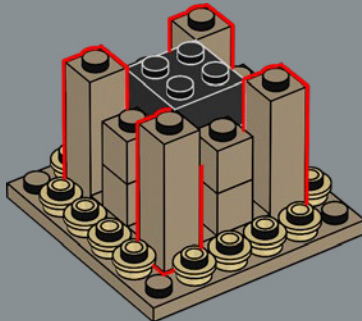

282

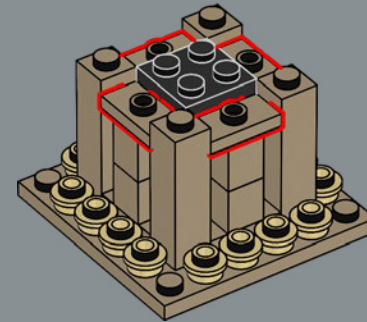

2x

283



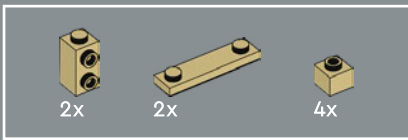

284

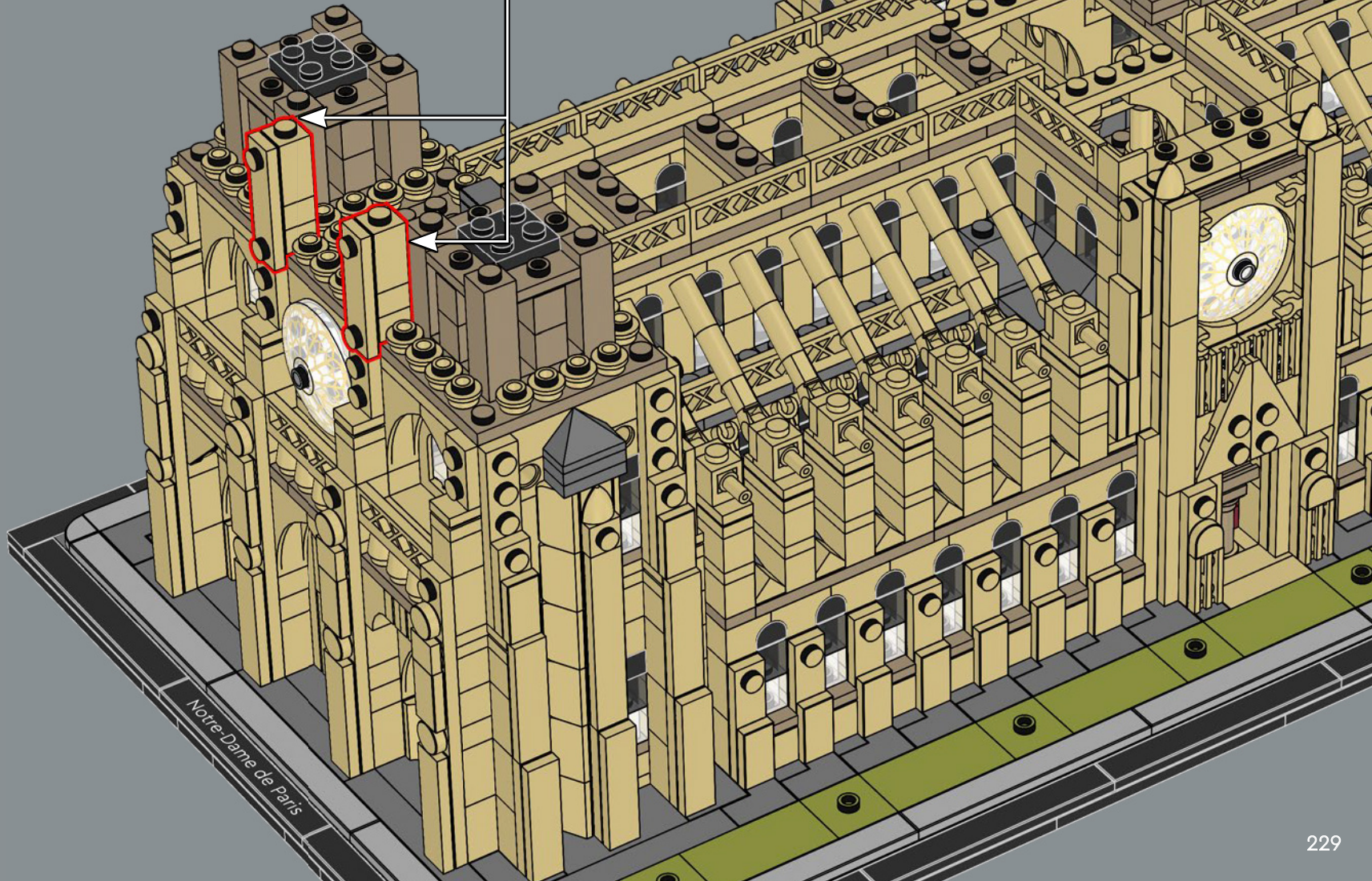
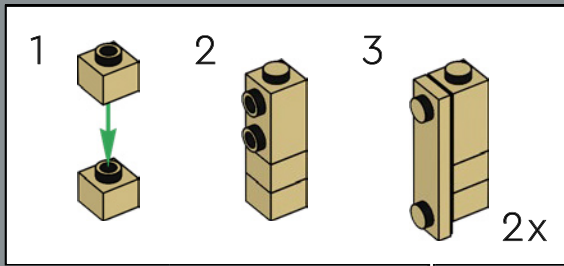



285

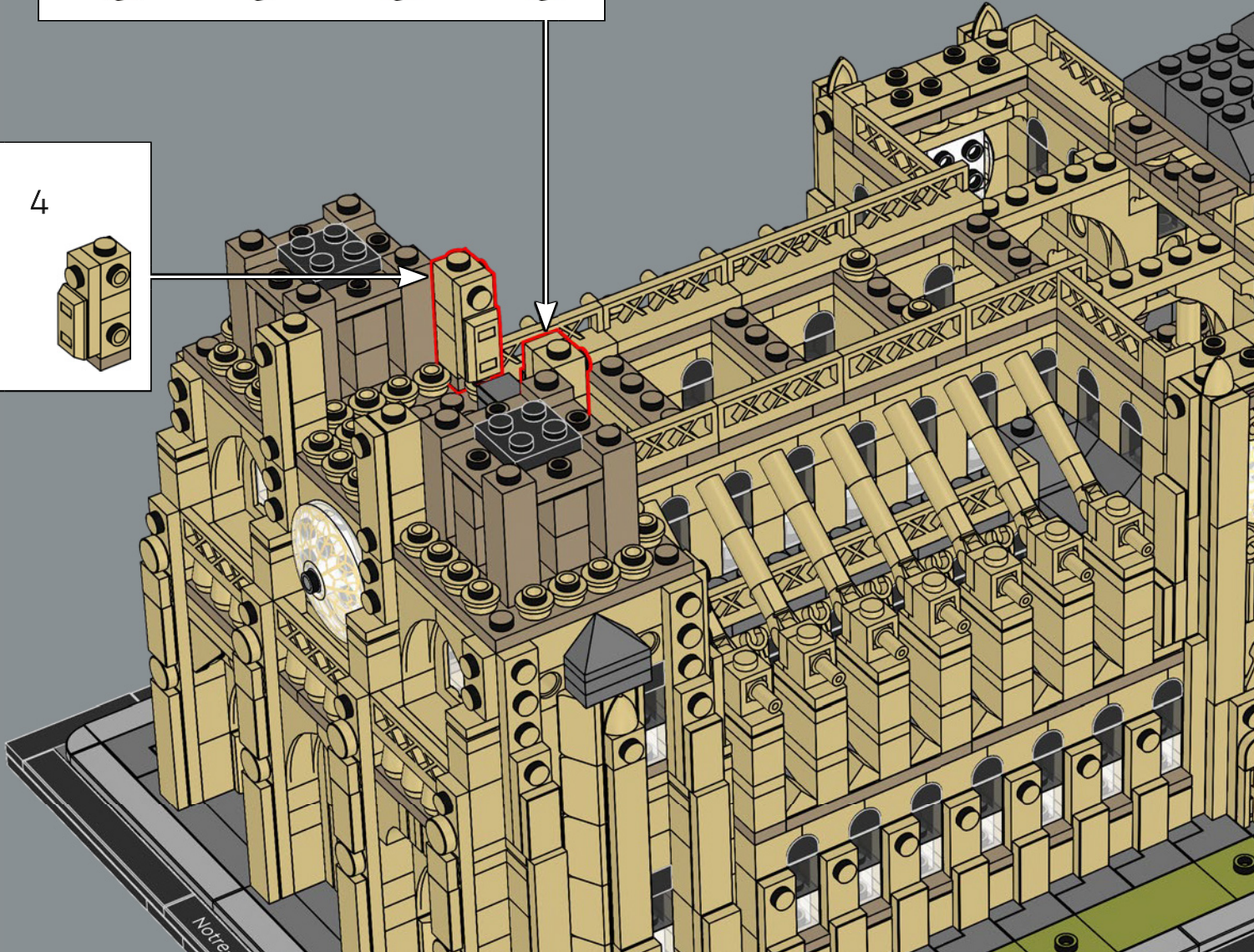
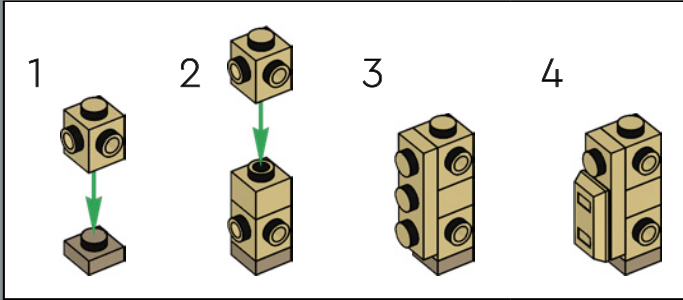
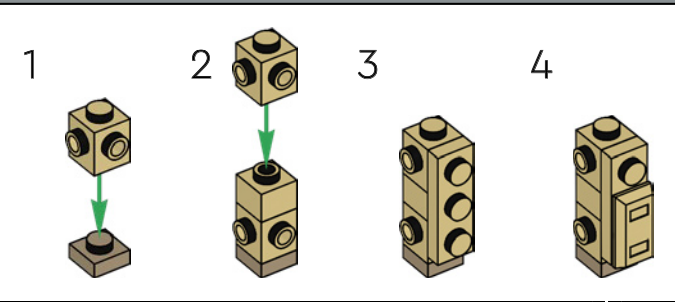

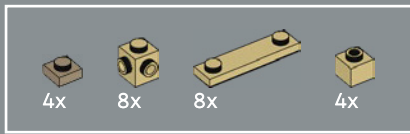

286

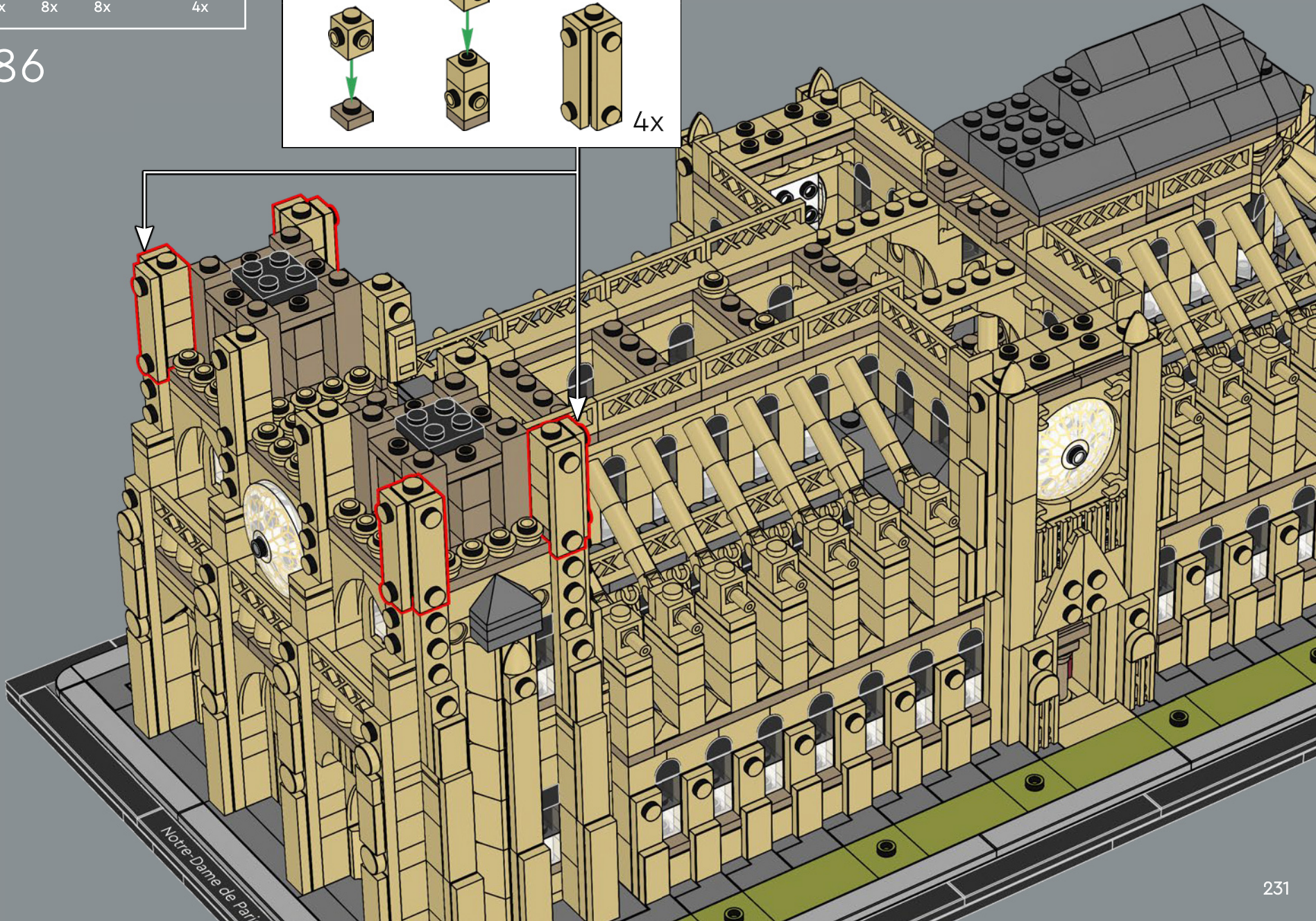
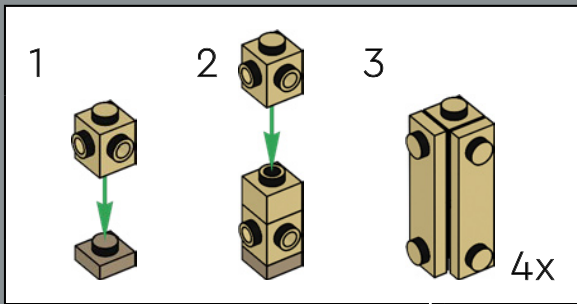

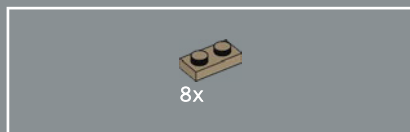

287

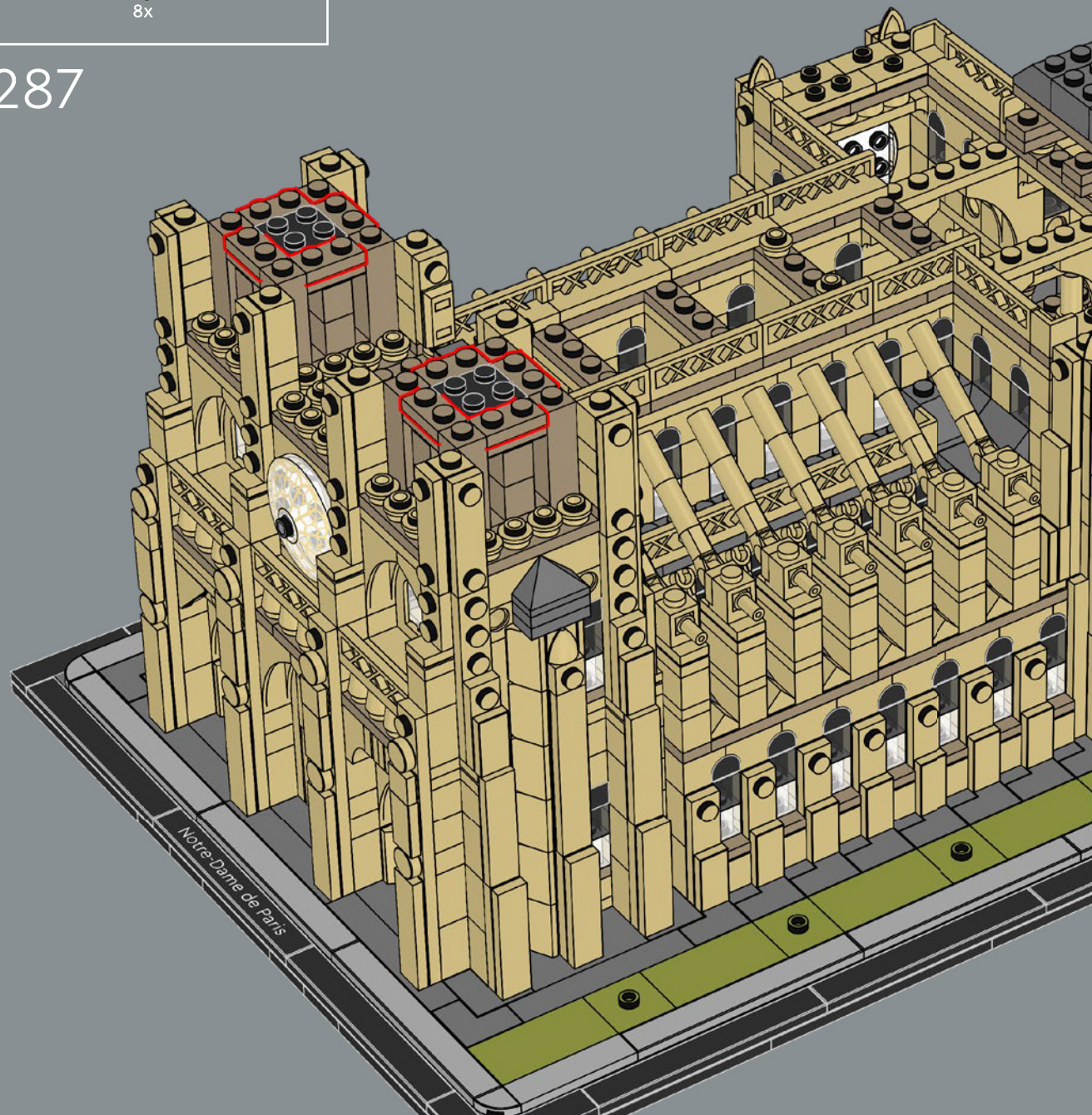



40x

288

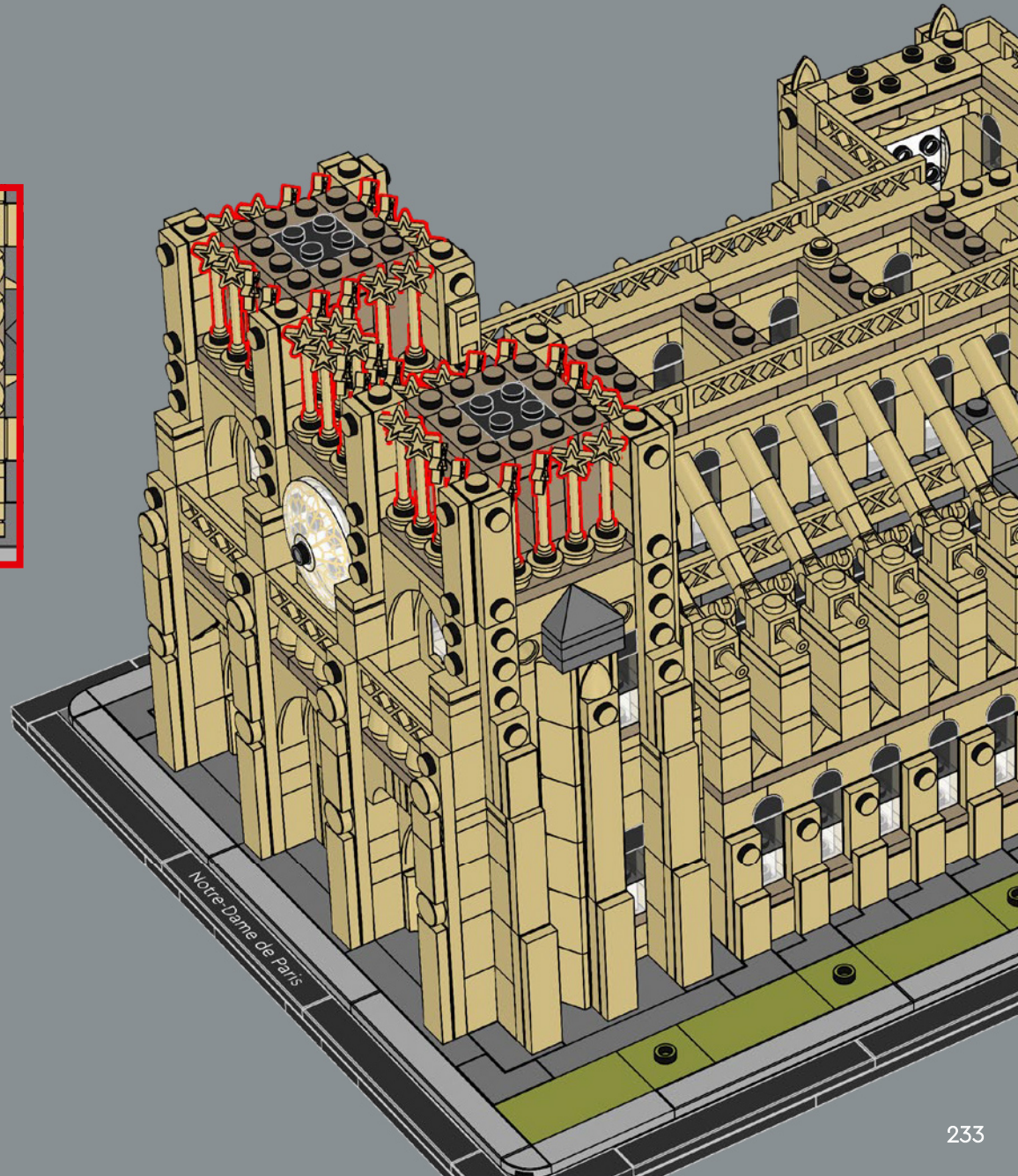
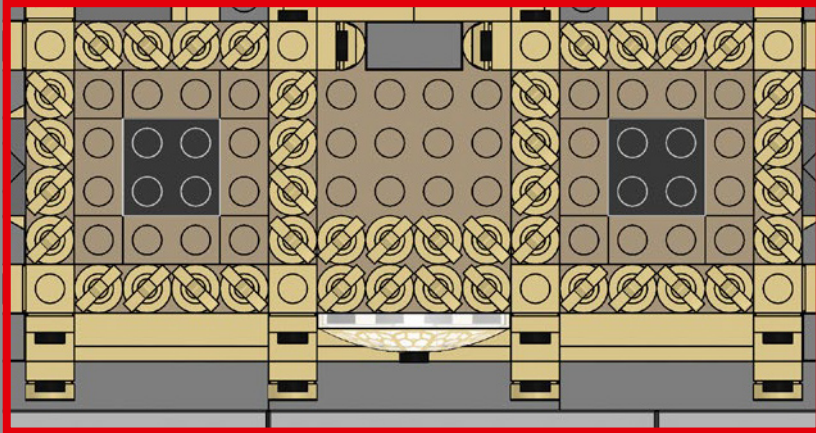

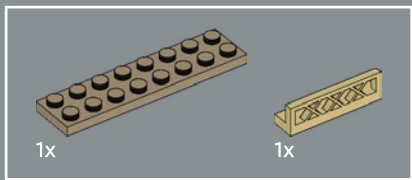

289

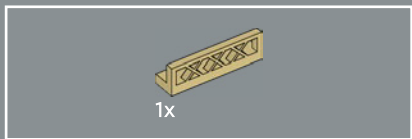
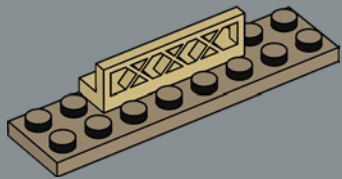

290

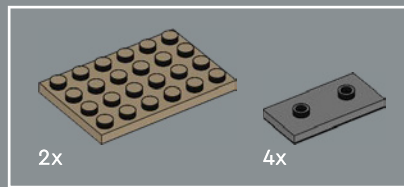
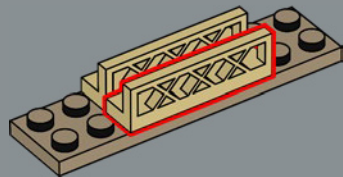

291

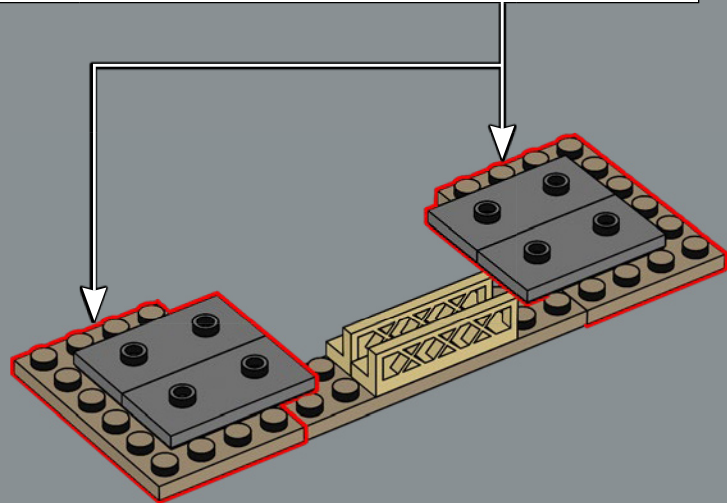
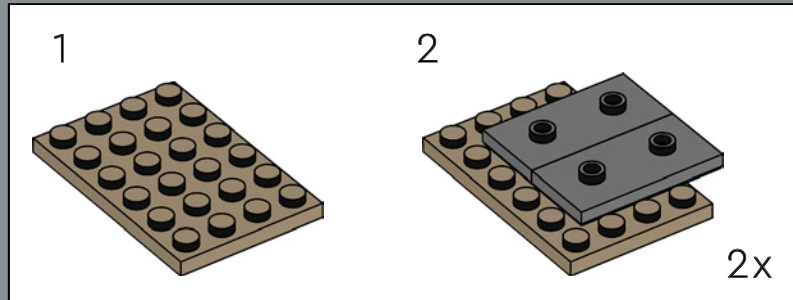

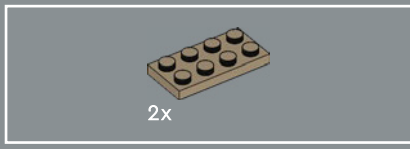

292

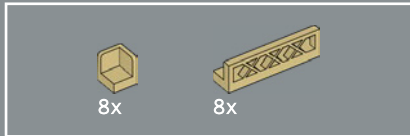
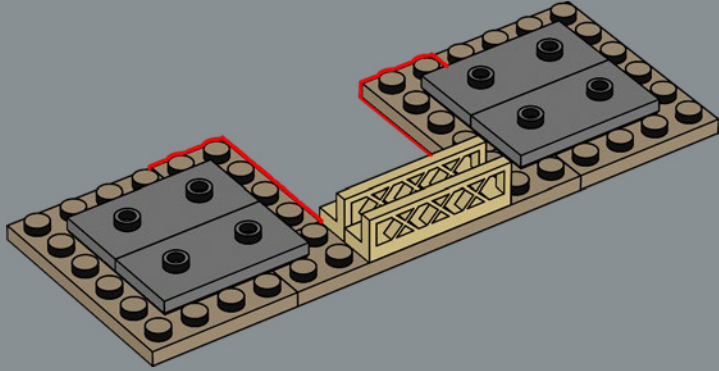

293

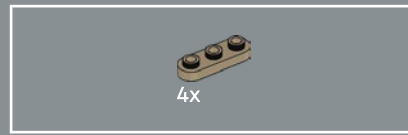
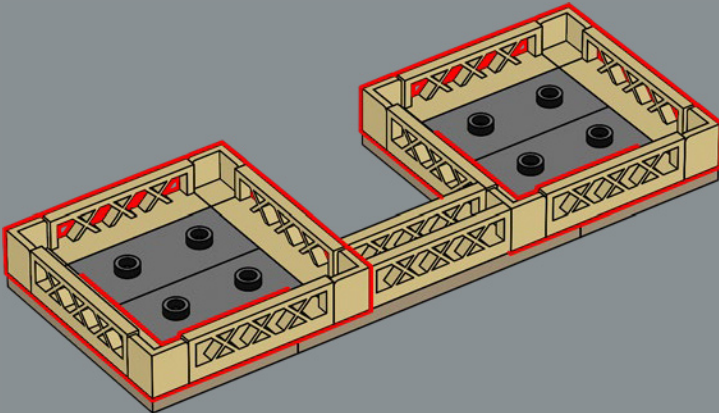

294

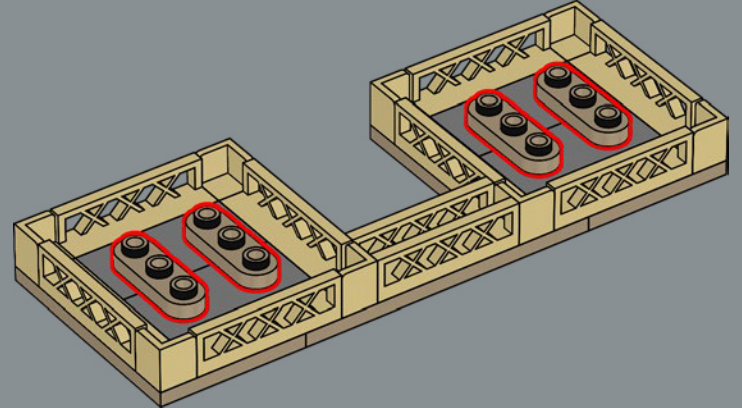

295

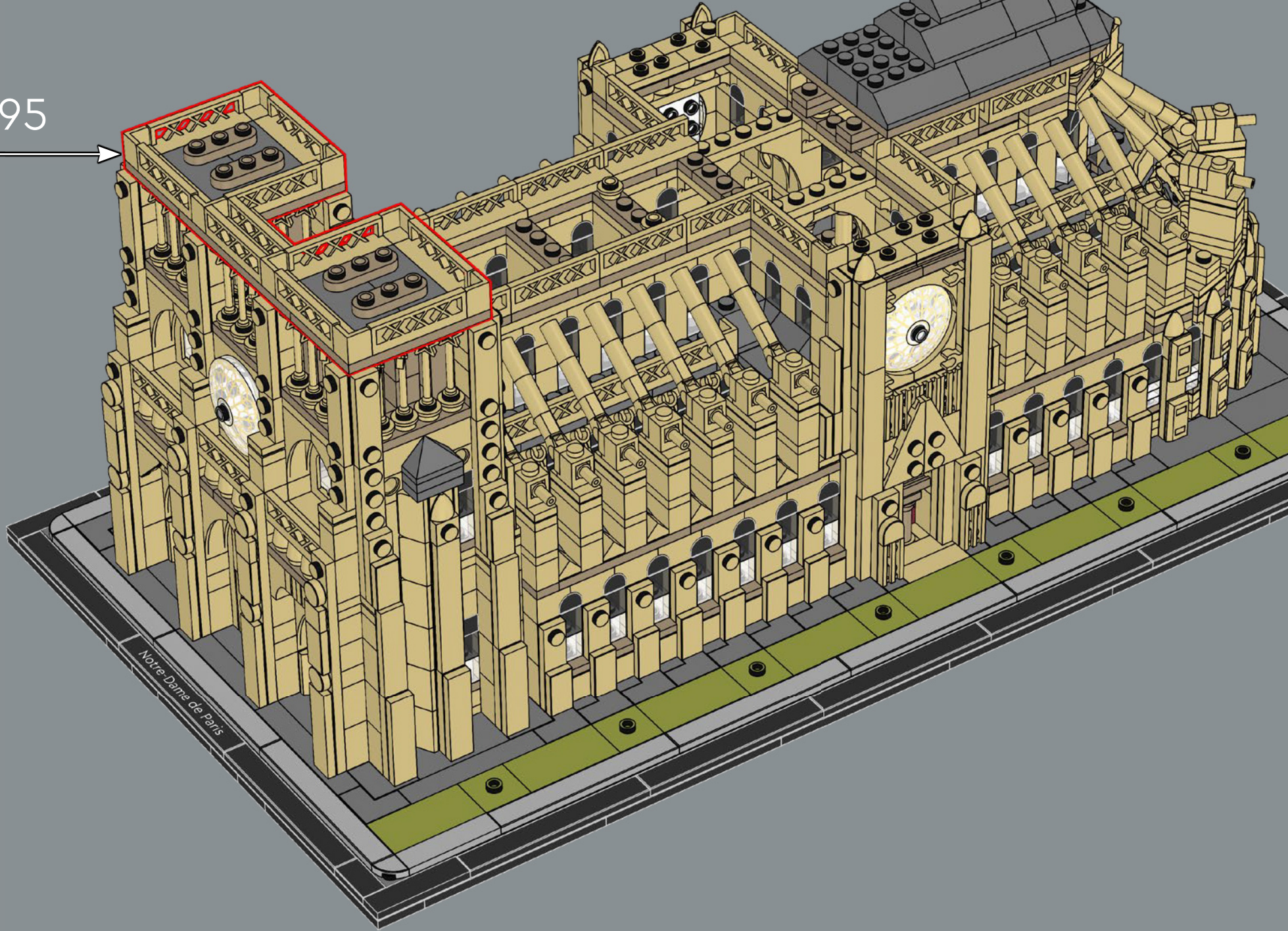

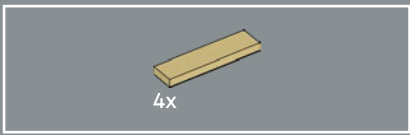

296

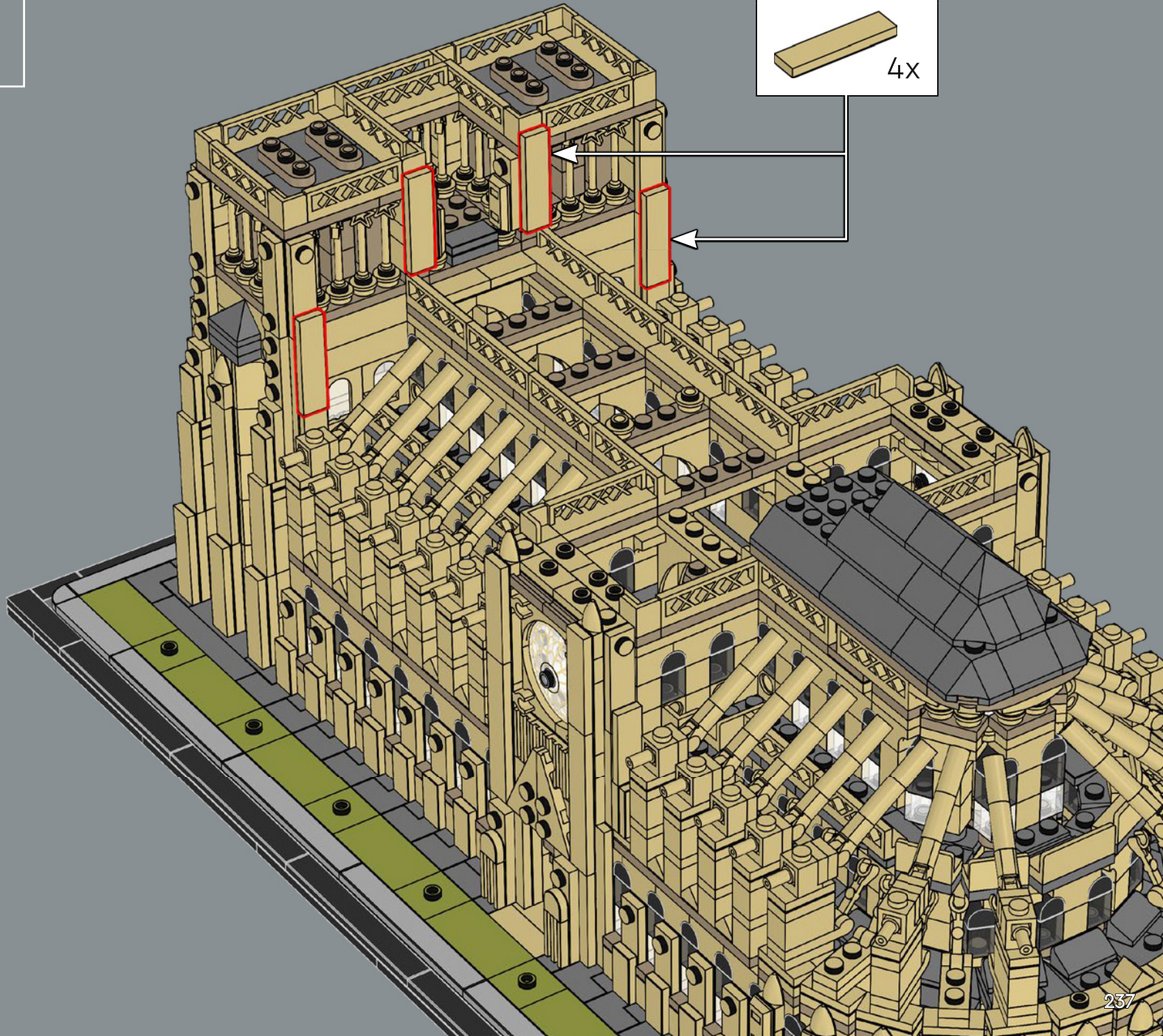
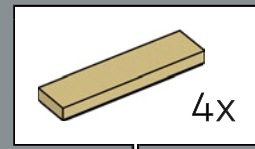



297

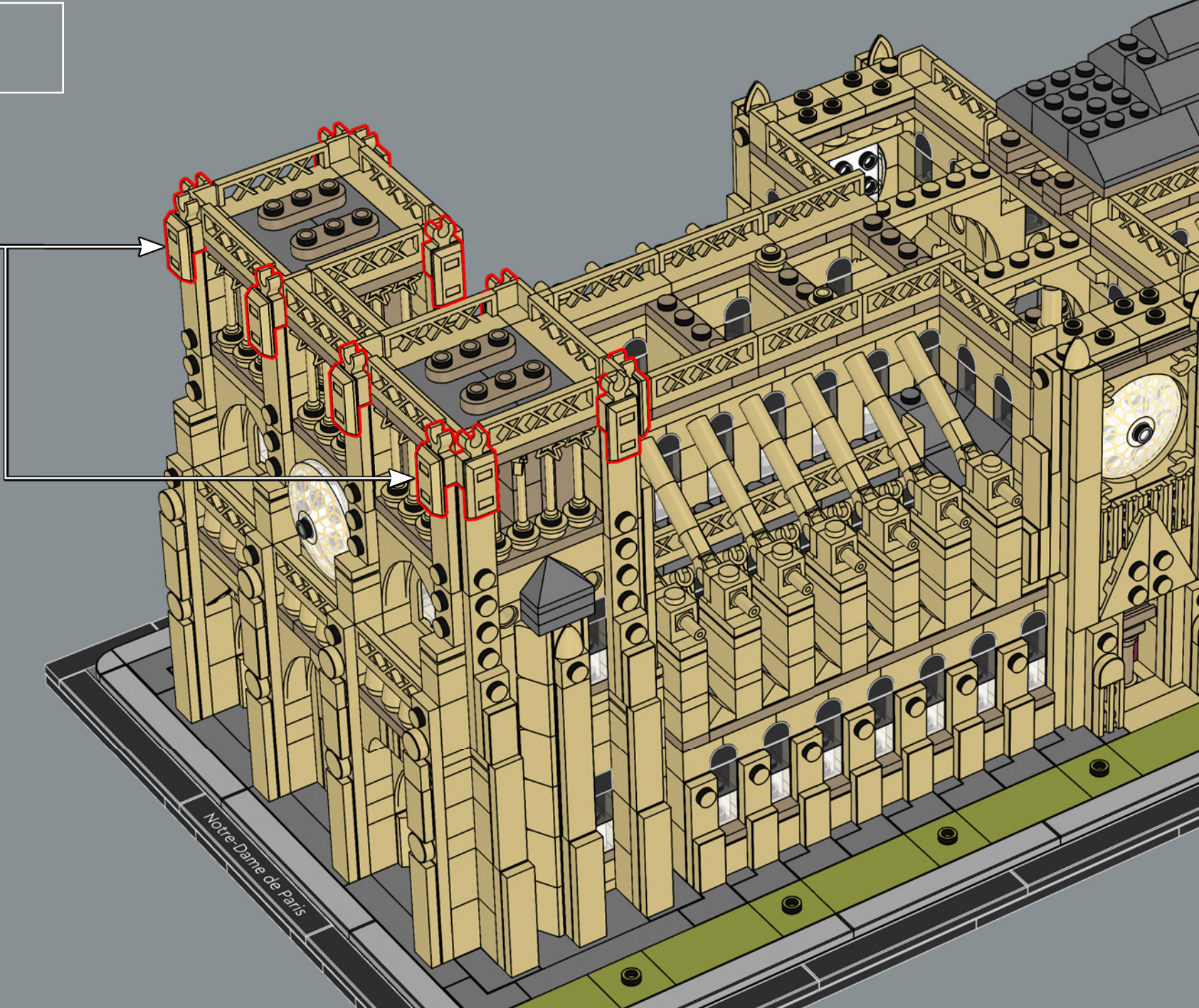
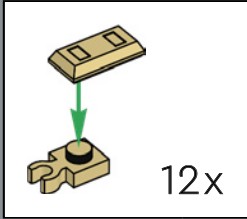

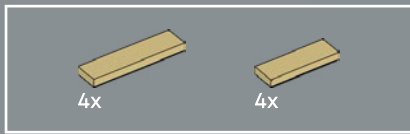

298

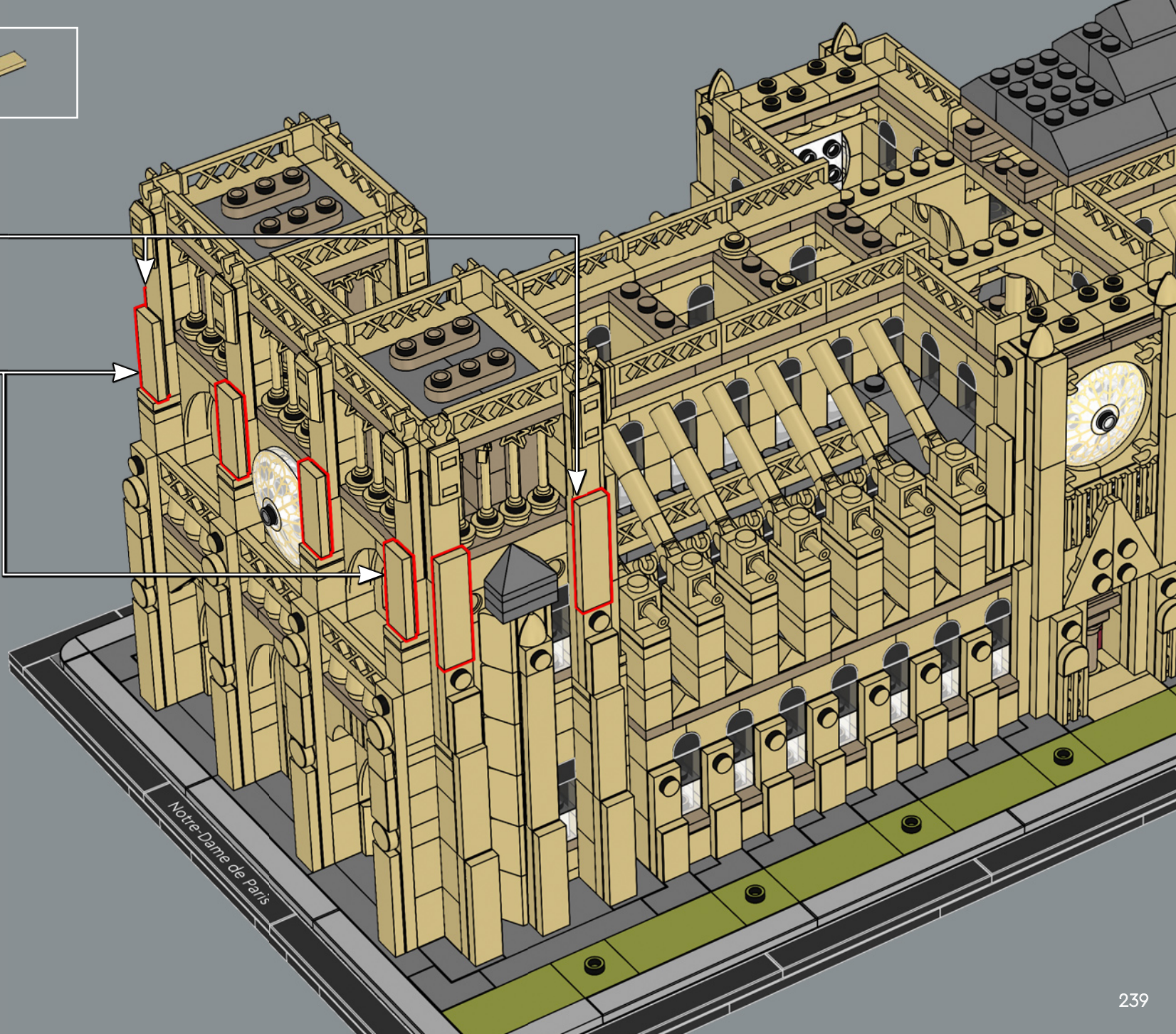
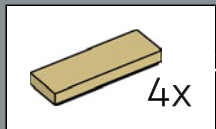
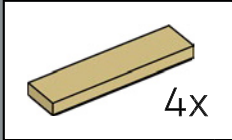



4x

299



4x

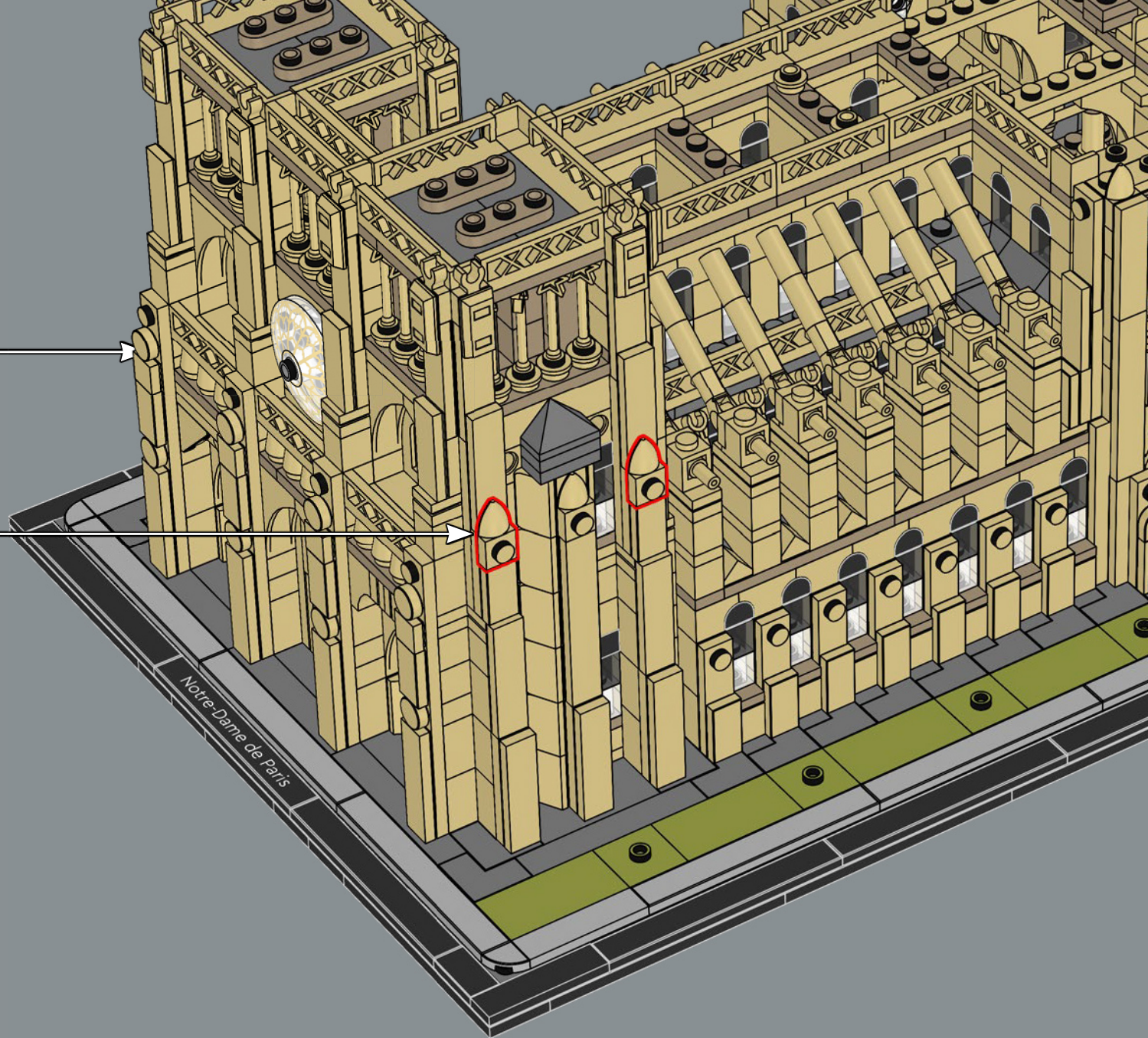

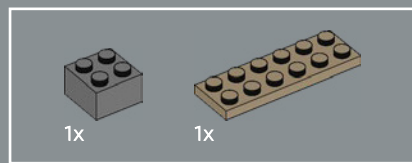
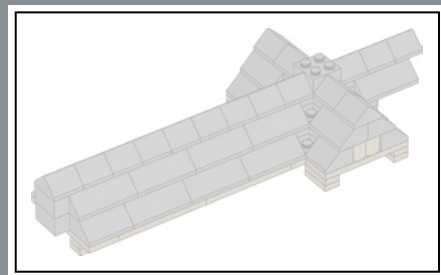

300

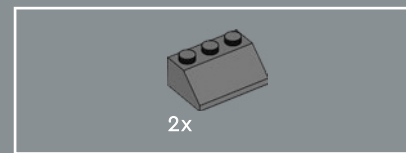
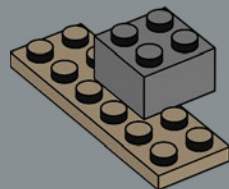

301

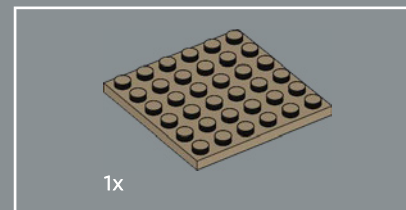
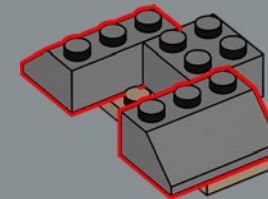

302

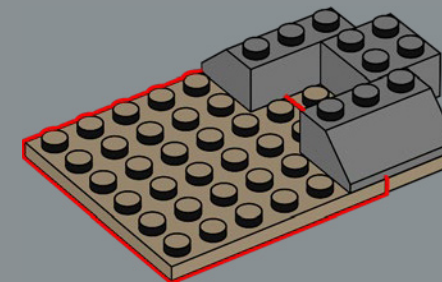

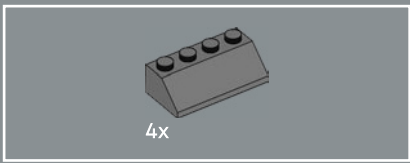

303

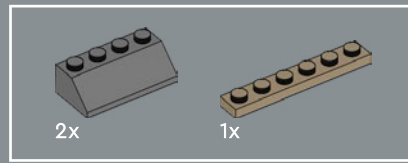
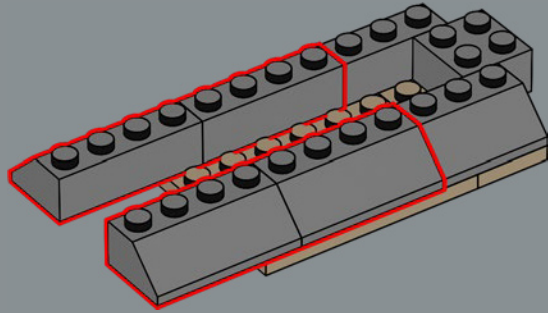

305

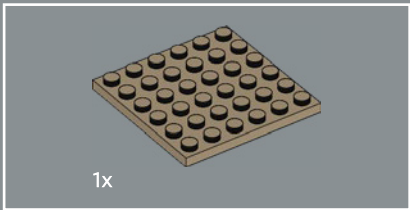
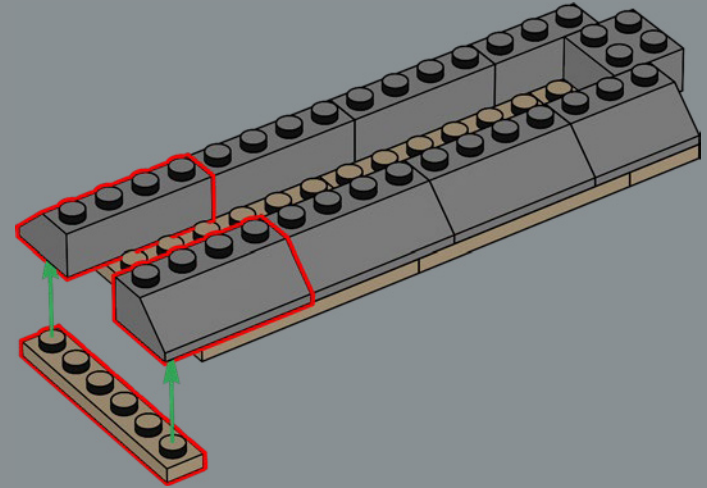

304

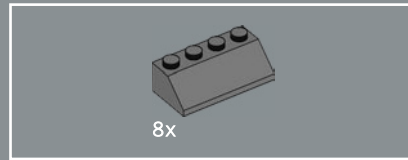
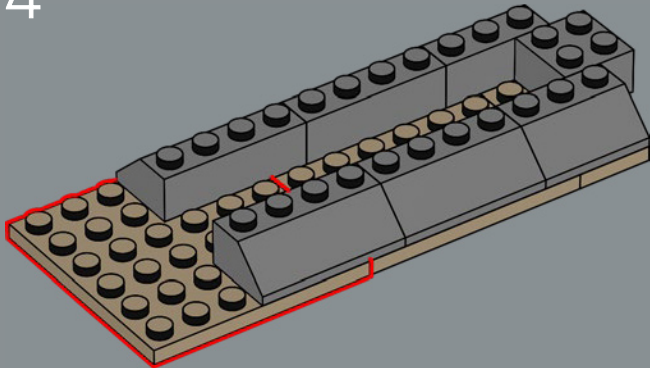

306

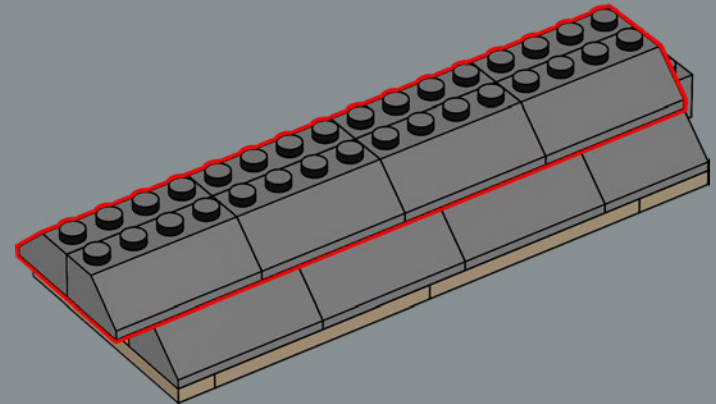

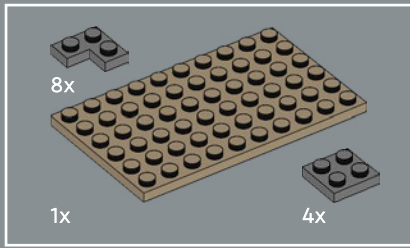

307

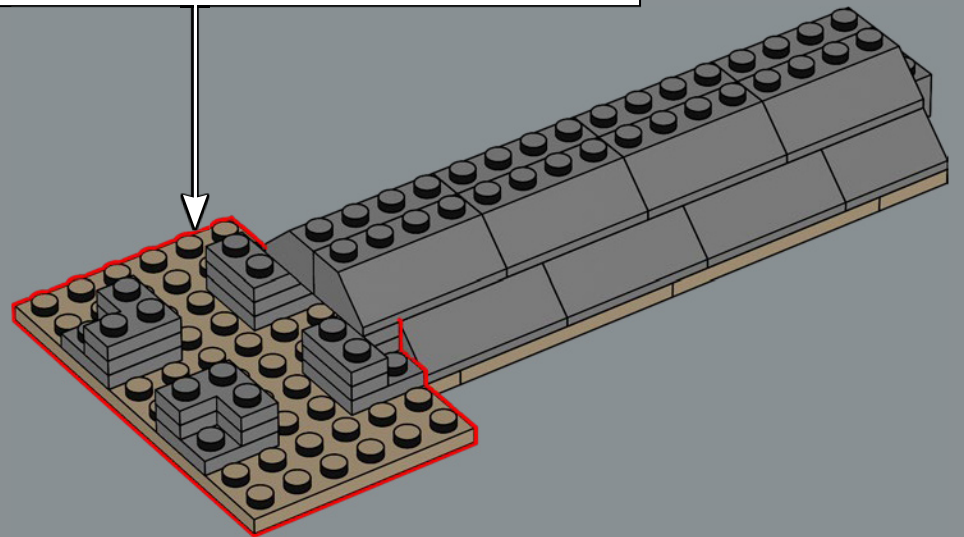
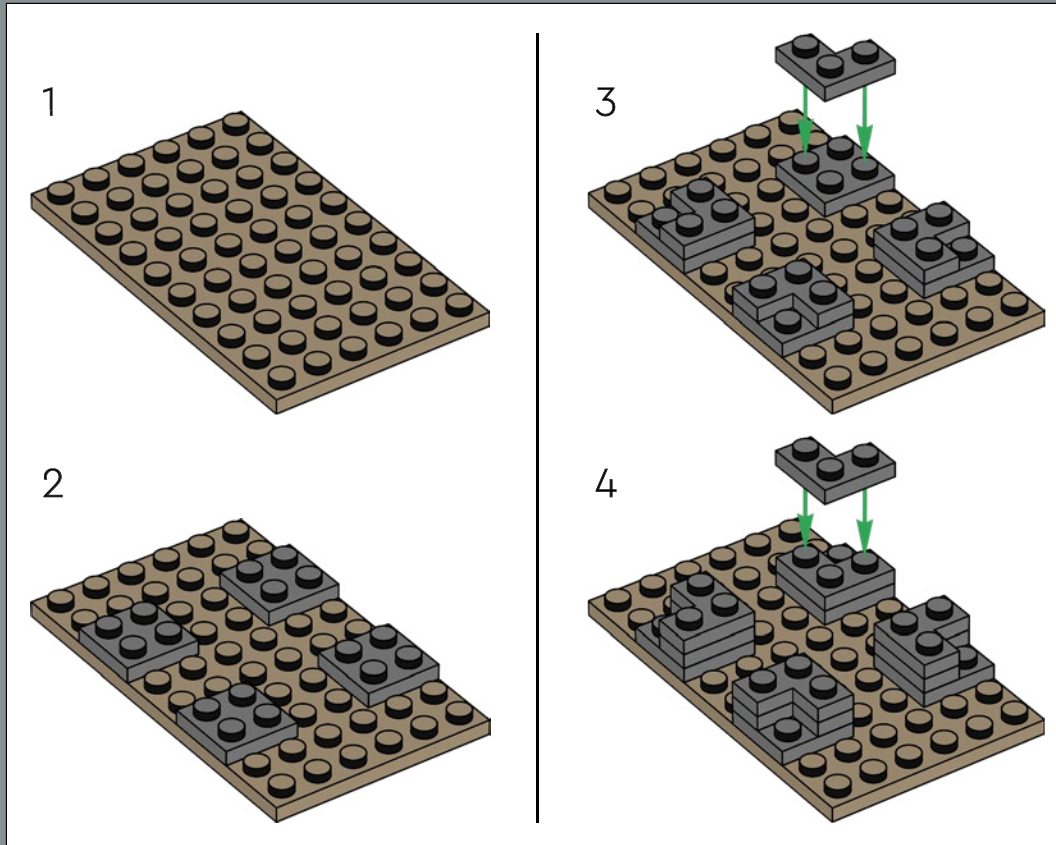

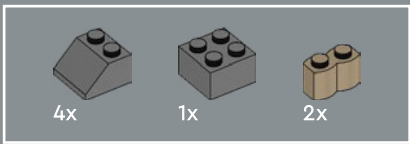

308

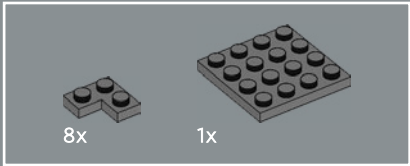
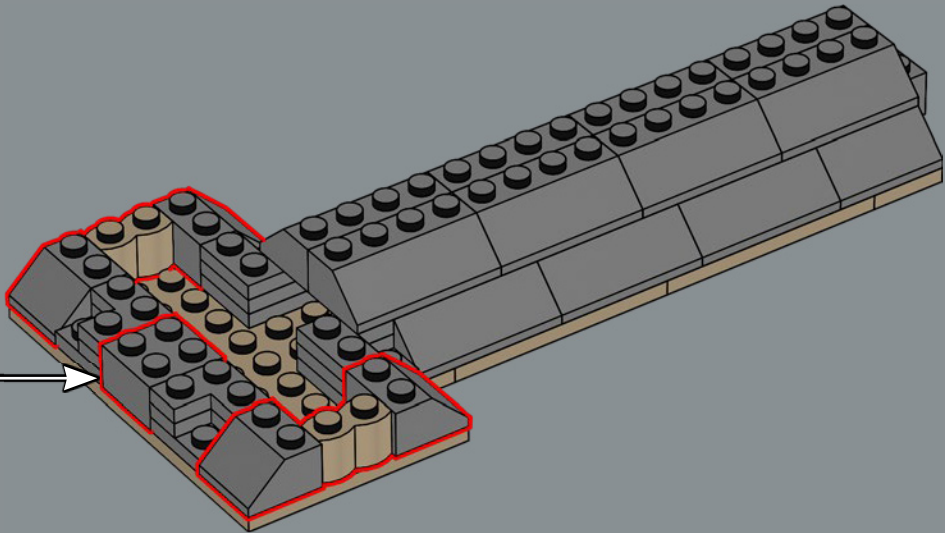
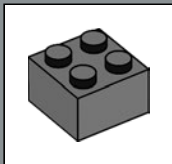

309

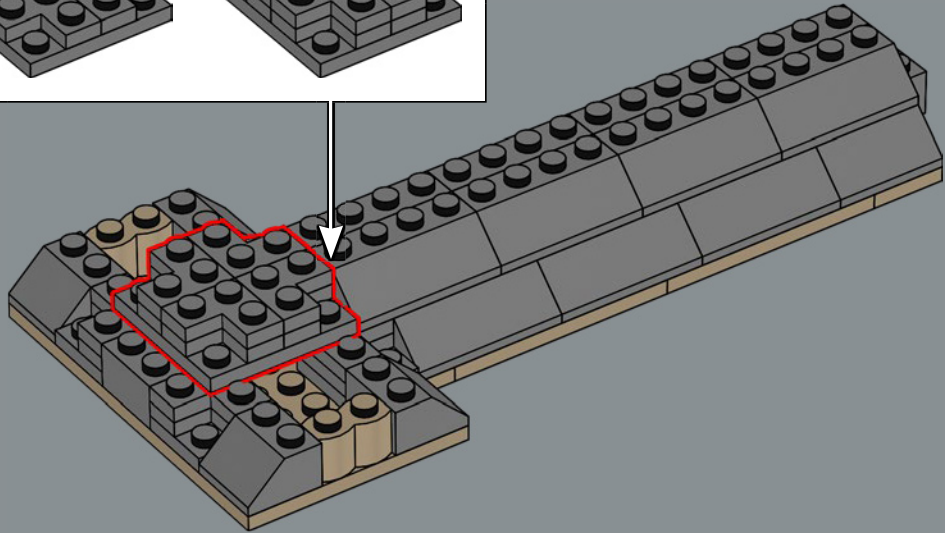
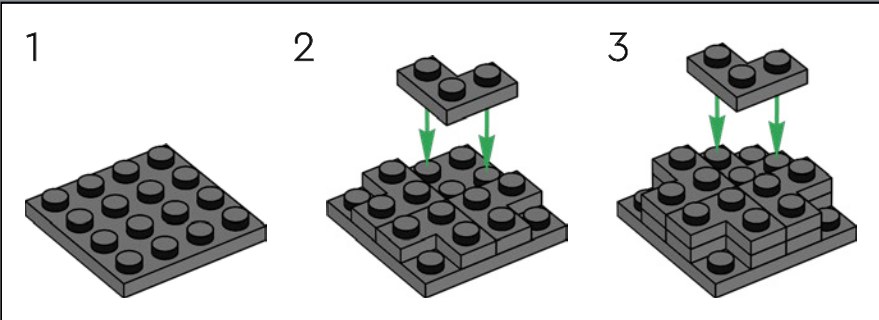

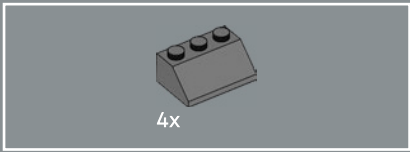

310

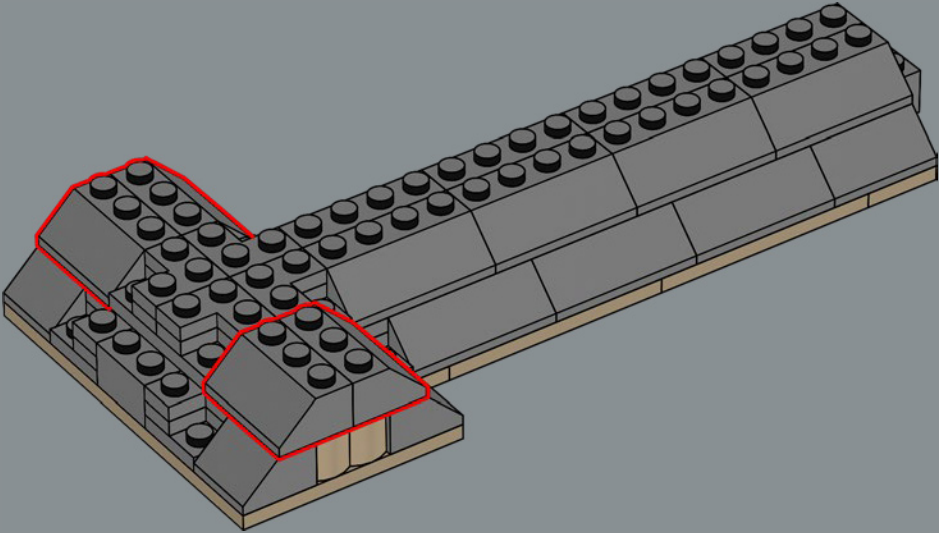

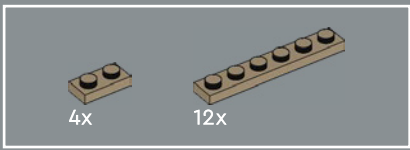

311

1

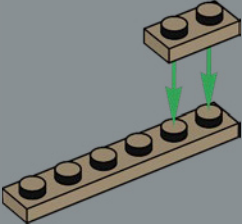

2

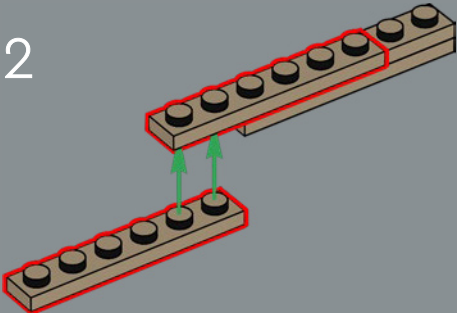

3

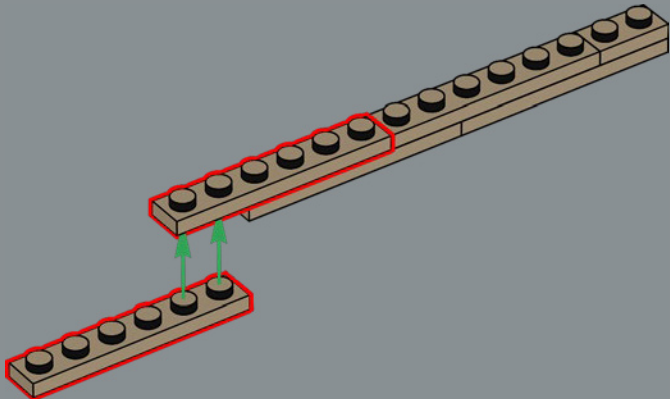

4

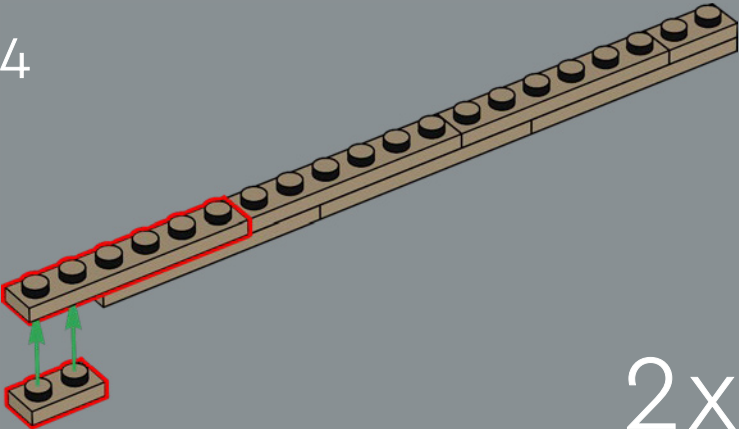

2x

用于巴黎圣母院木质结构的木材来自大约 1300 棵橡树，
大约相当于 21 公顷 (51.8 英亩) 的森林！

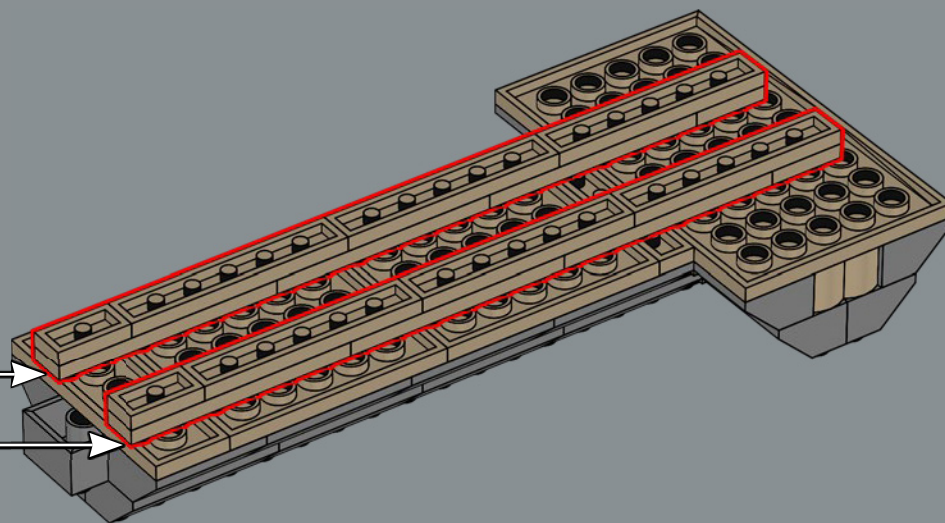



8x

312

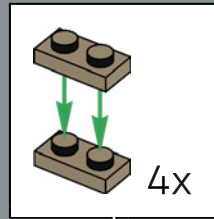

4x

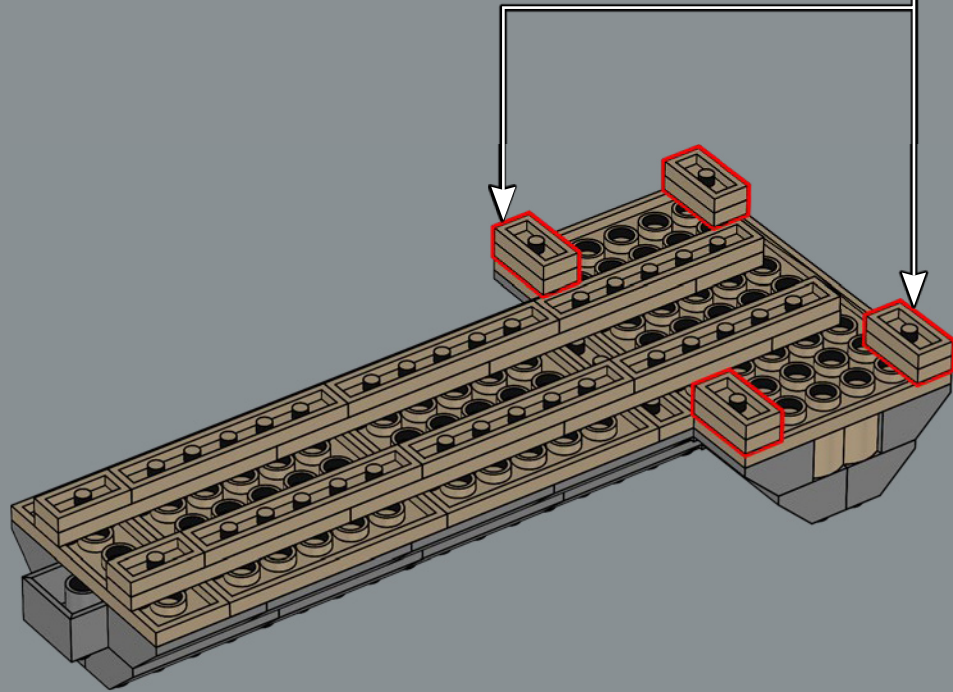

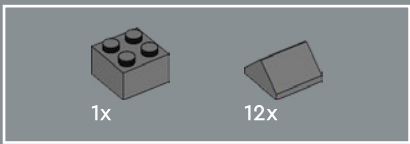

313

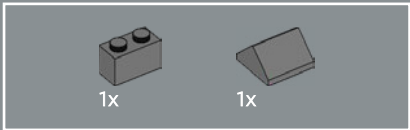
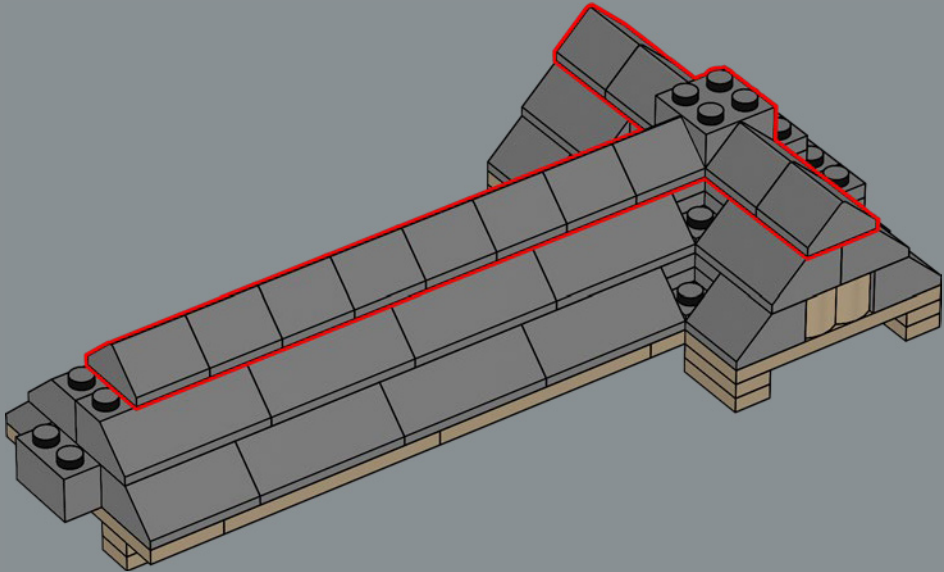

314

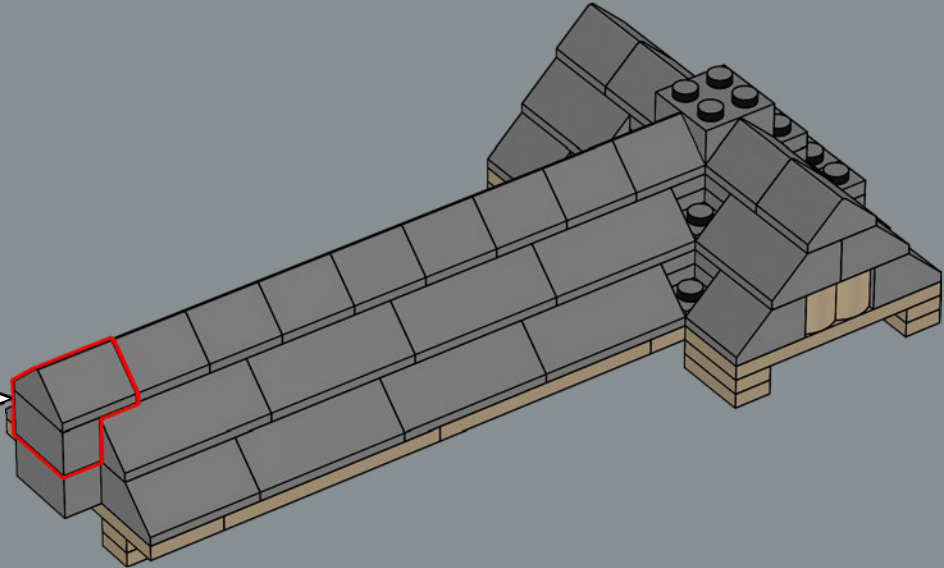
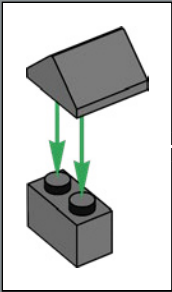

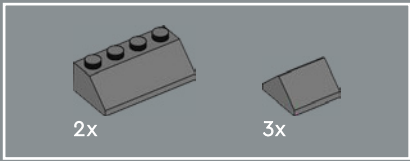

315

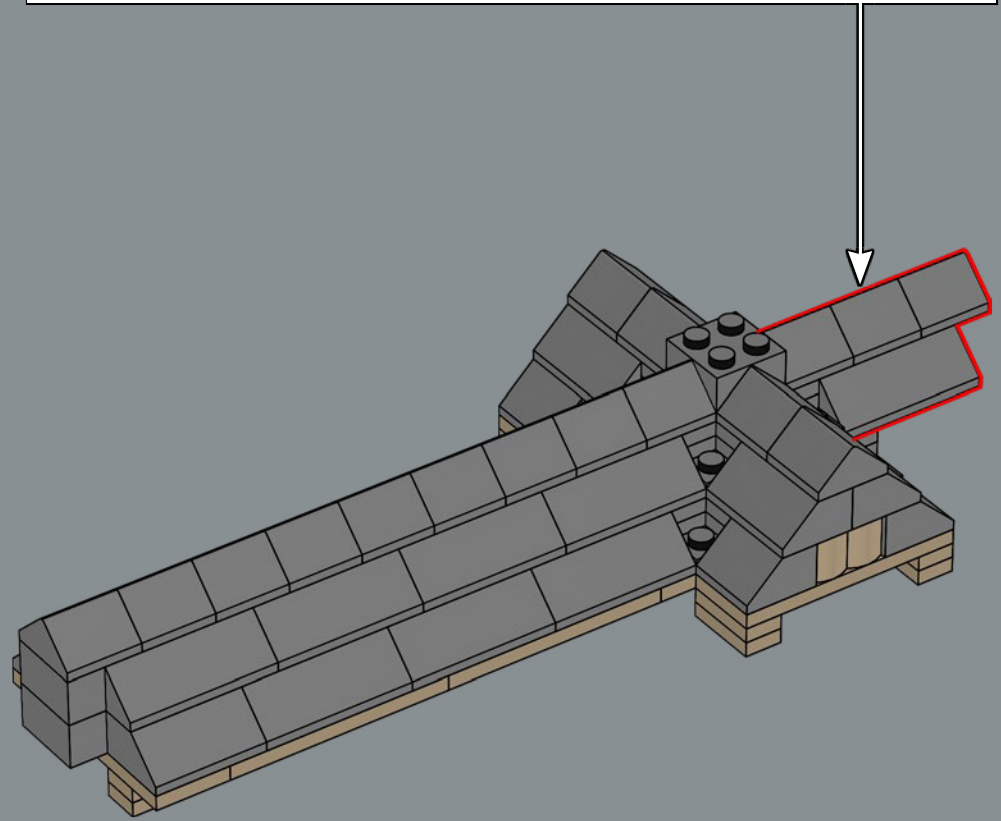
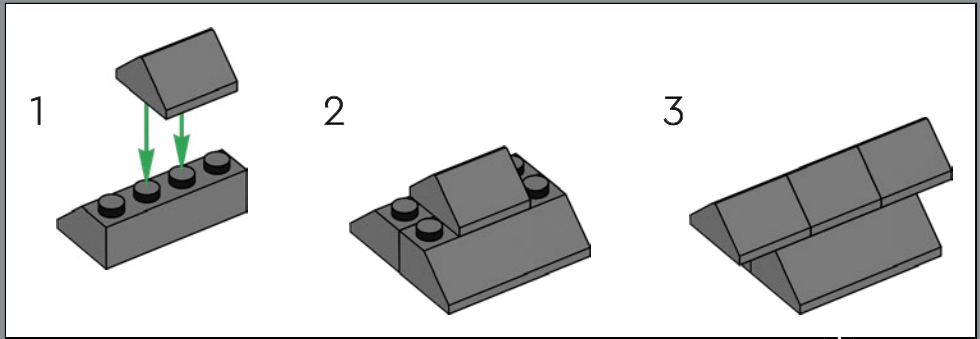

316

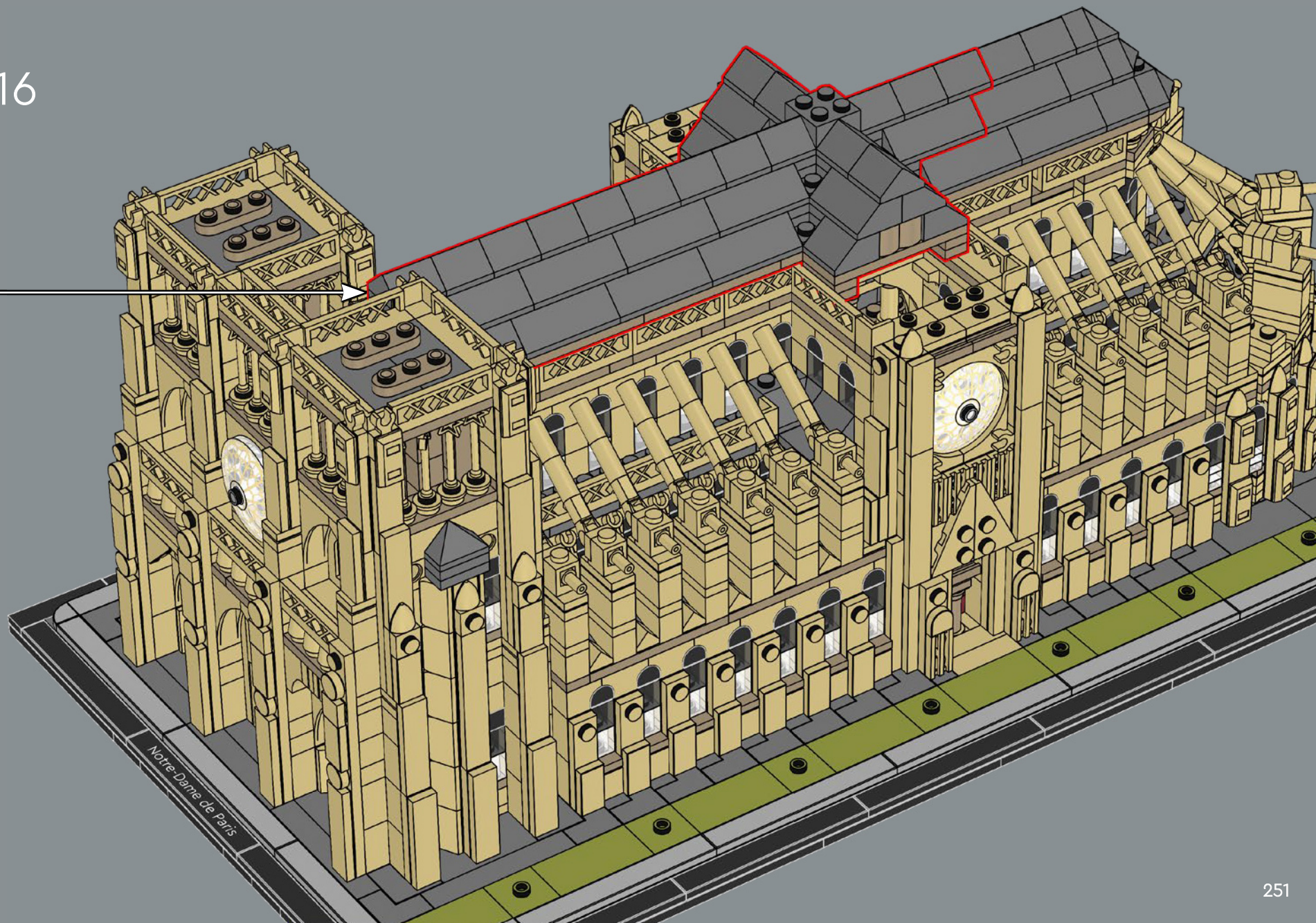

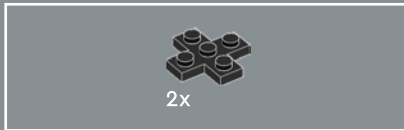
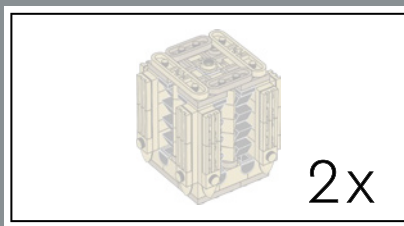

317

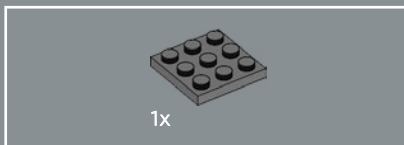
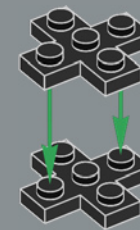

318

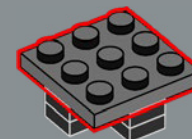

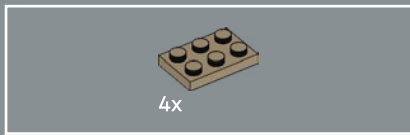

319

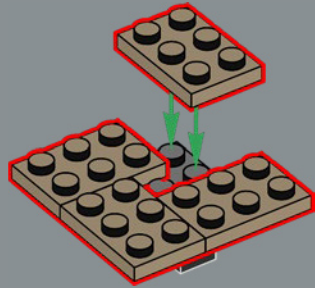

320

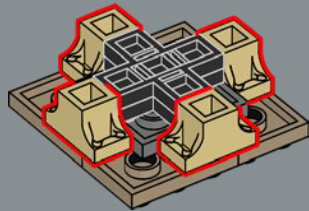

321

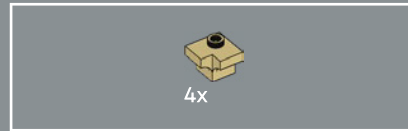
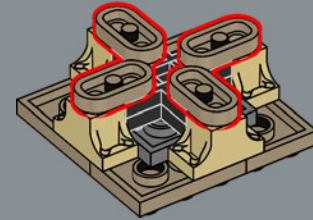

322

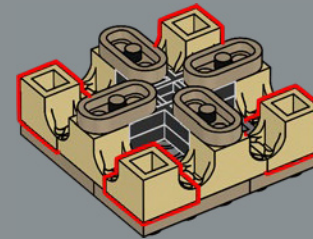



323

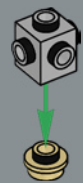

324

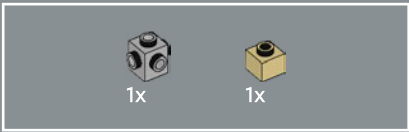

325



326



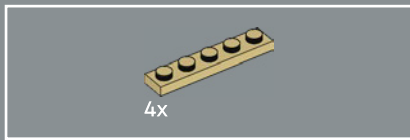

327

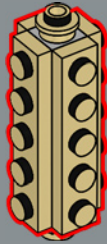

328

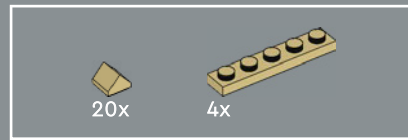
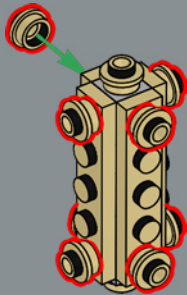

329

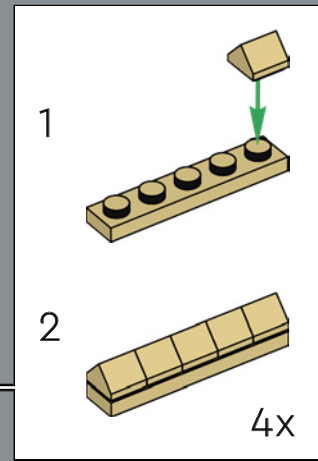
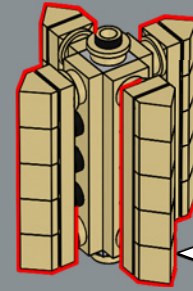

330

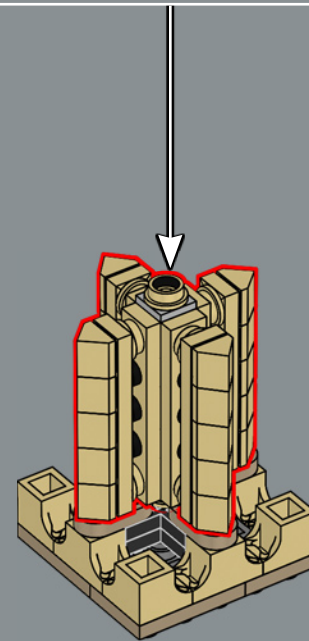

2x

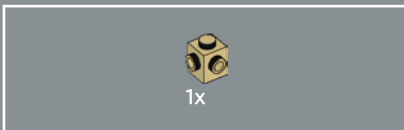

331

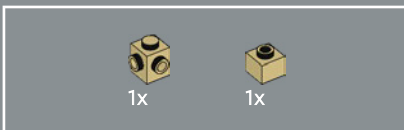

332

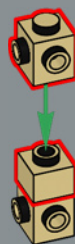

333



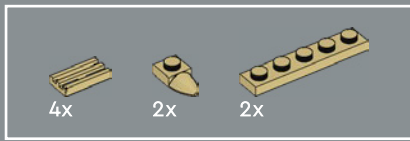

334

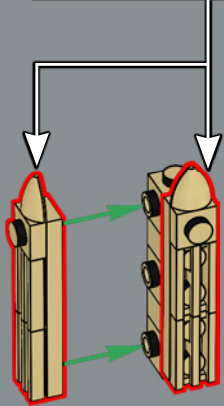
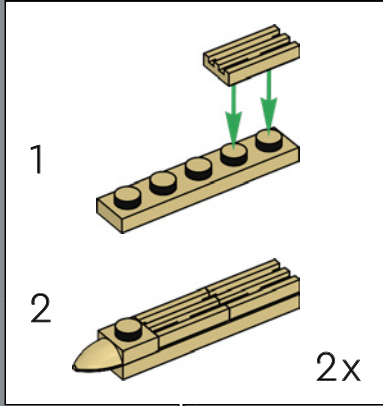

335

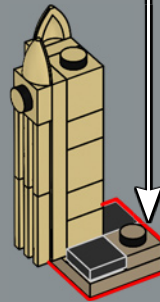
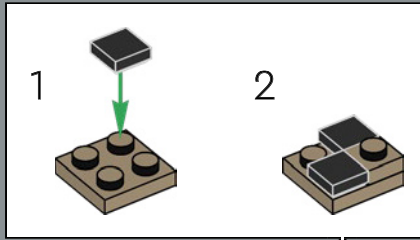

336

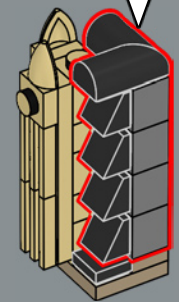
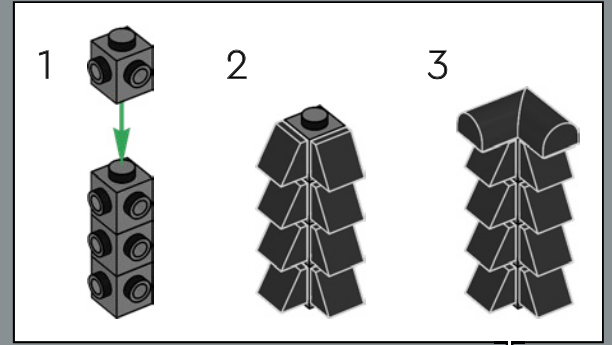

4x

337

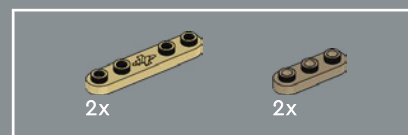
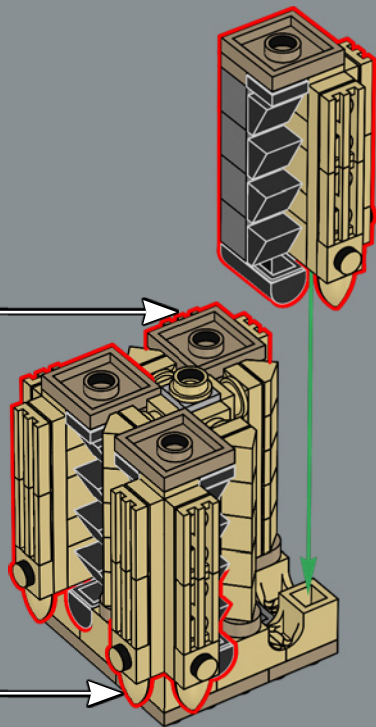

338

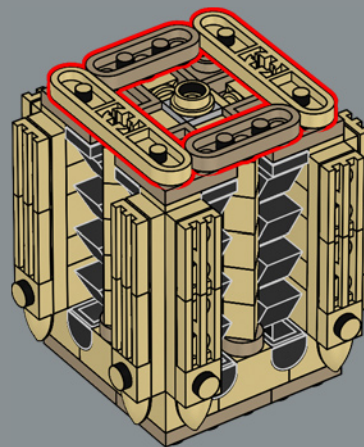

2x

塔楼内悬挂着巴黎圣母院的传奇大钟。它们先被安装在北塔内，
该塔也被称为 Grosse Tour 或 "Guillaume Tower"。

339

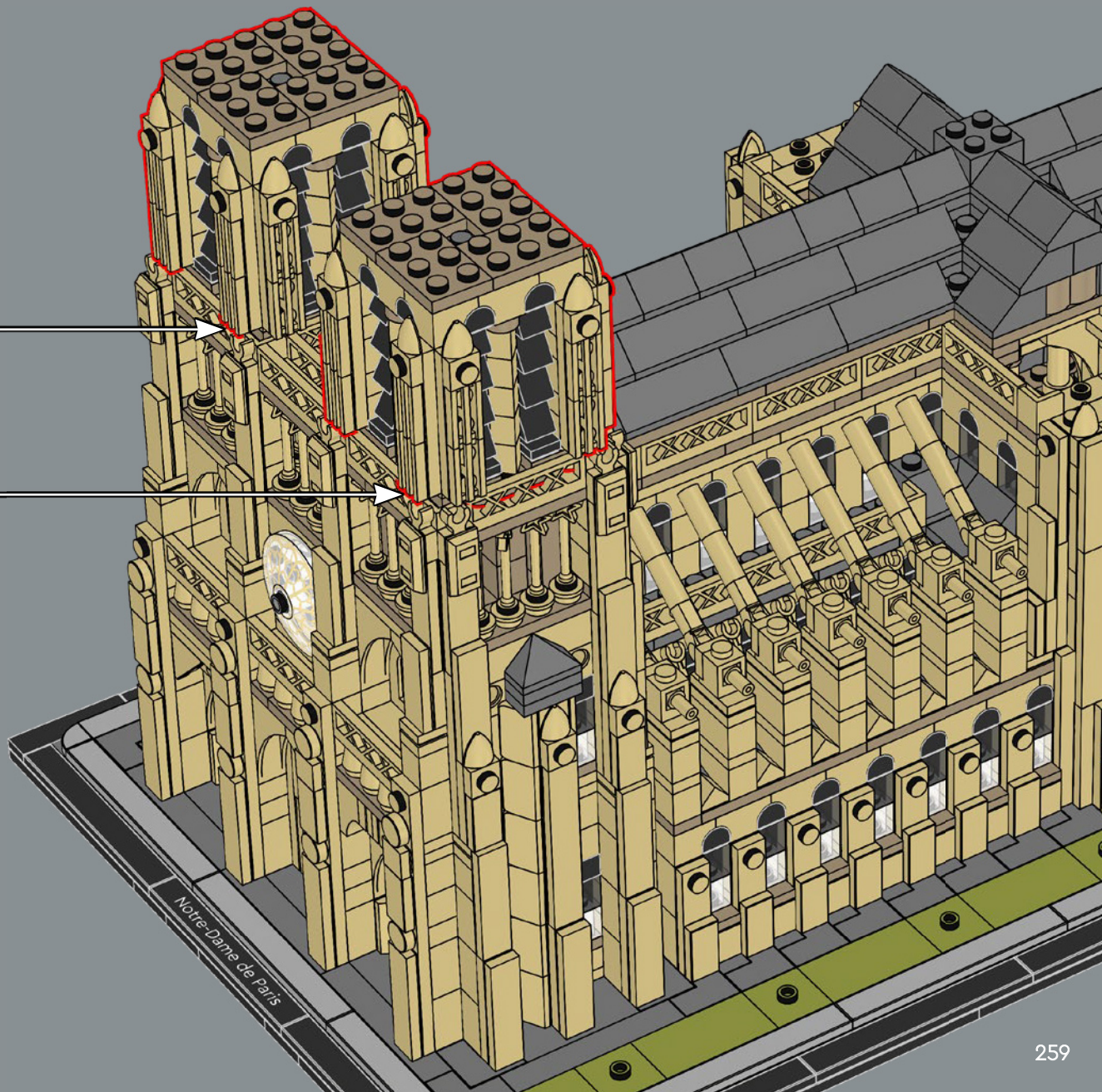



340

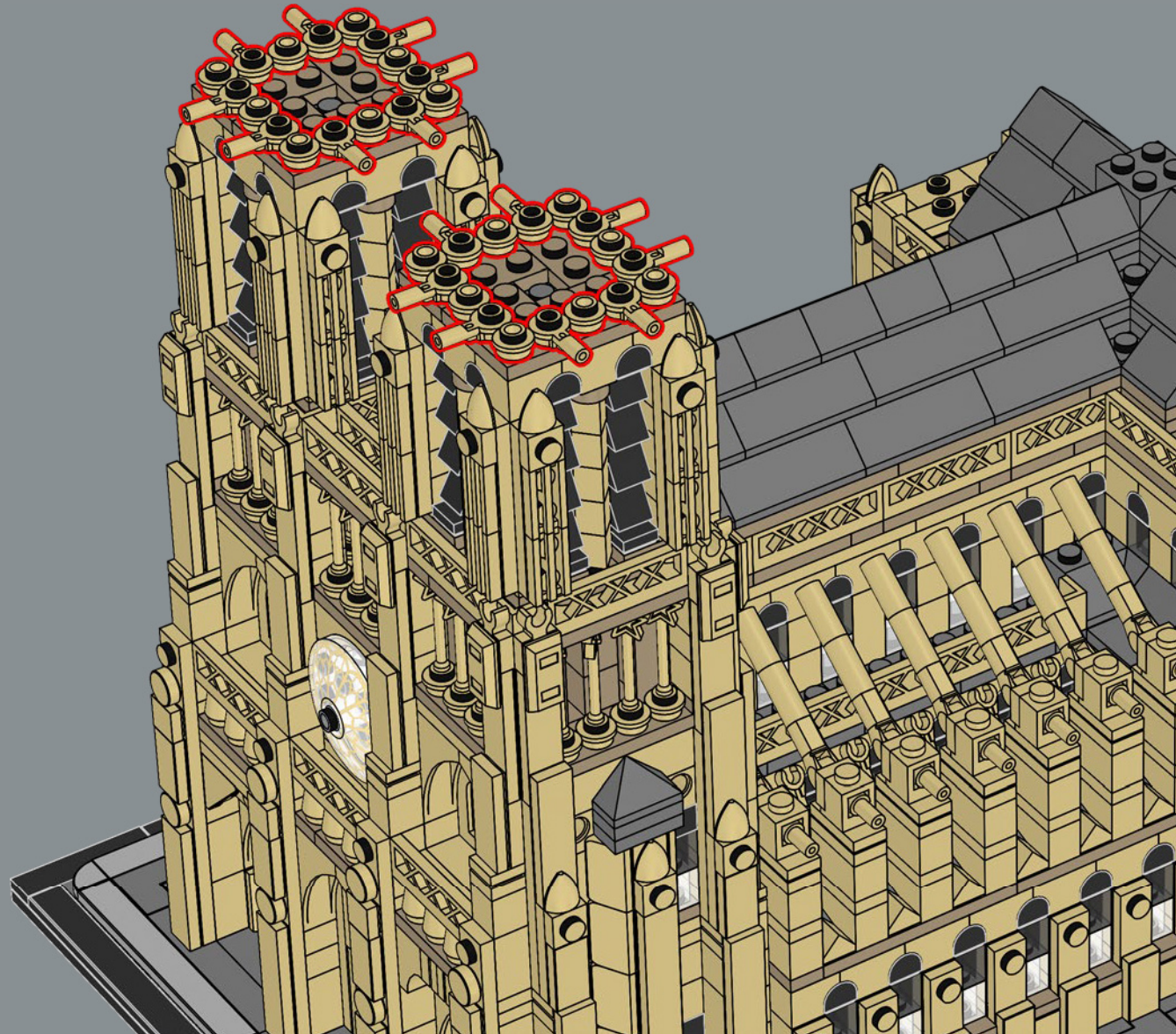



341

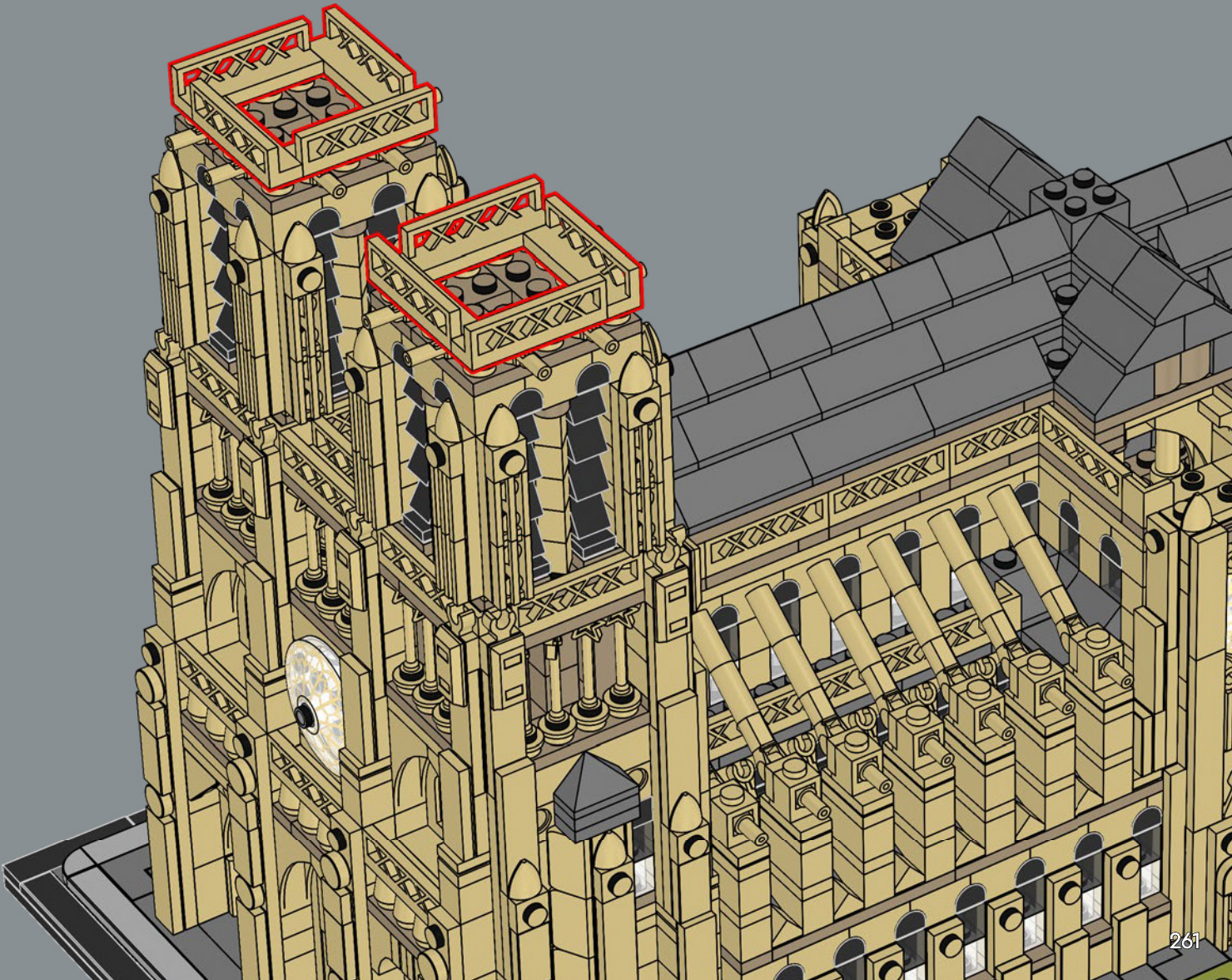

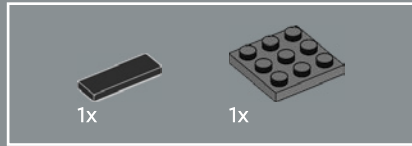
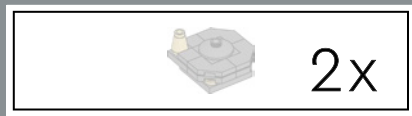

342

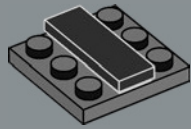

343

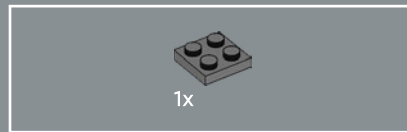
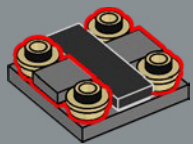

344

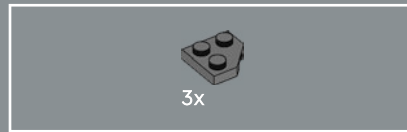
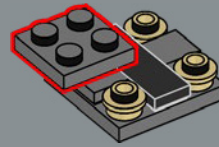

345

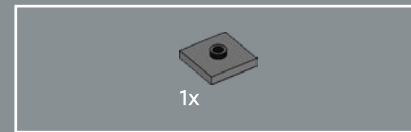
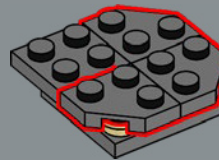

346

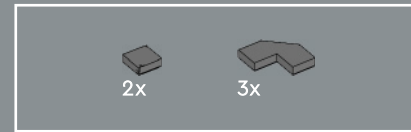
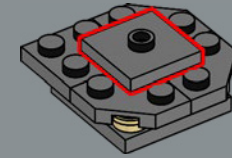

347

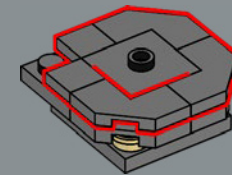



348

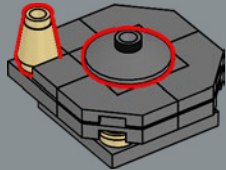

2x

349

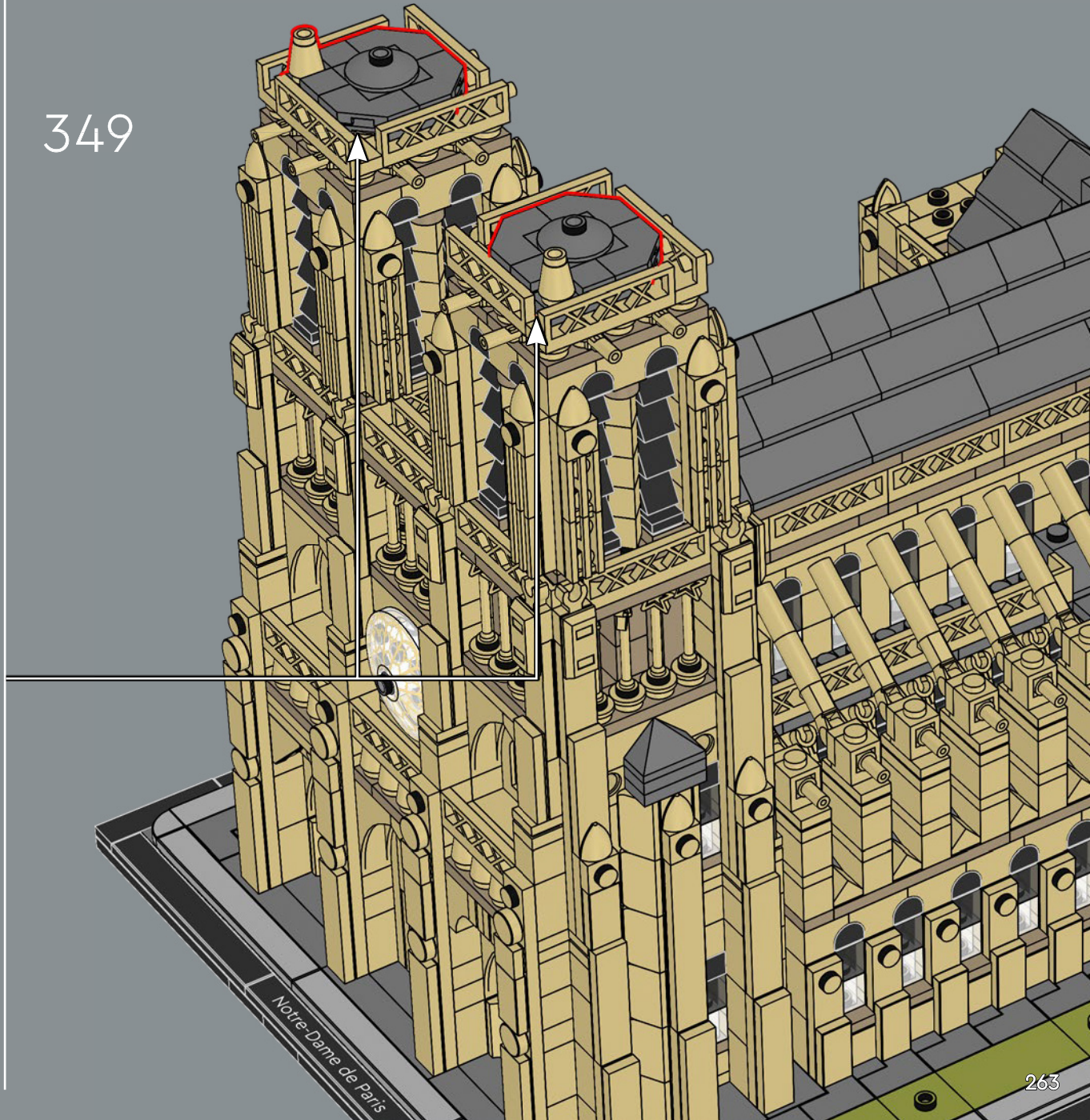

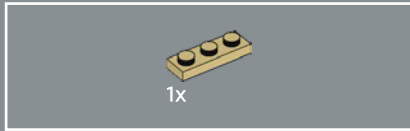
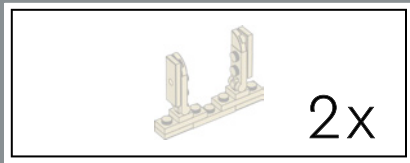

350

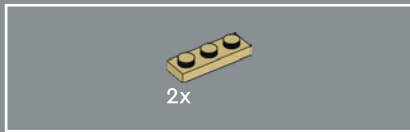
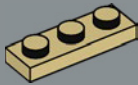

351

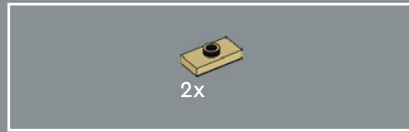
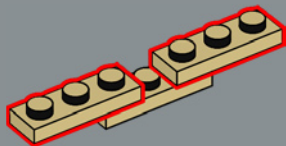

352

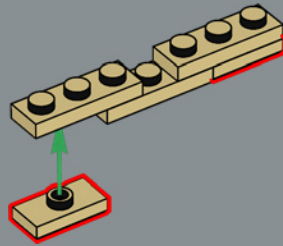

353

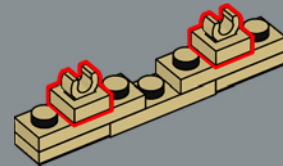

354

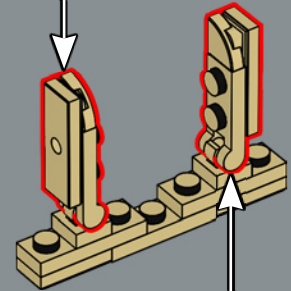
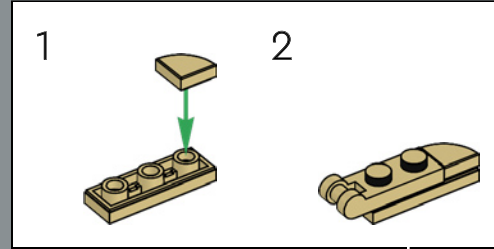

2x

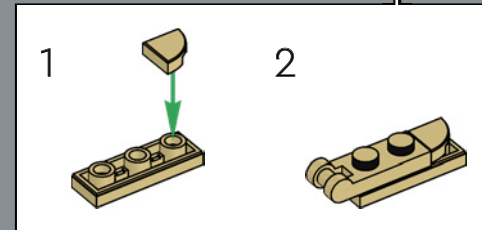

355

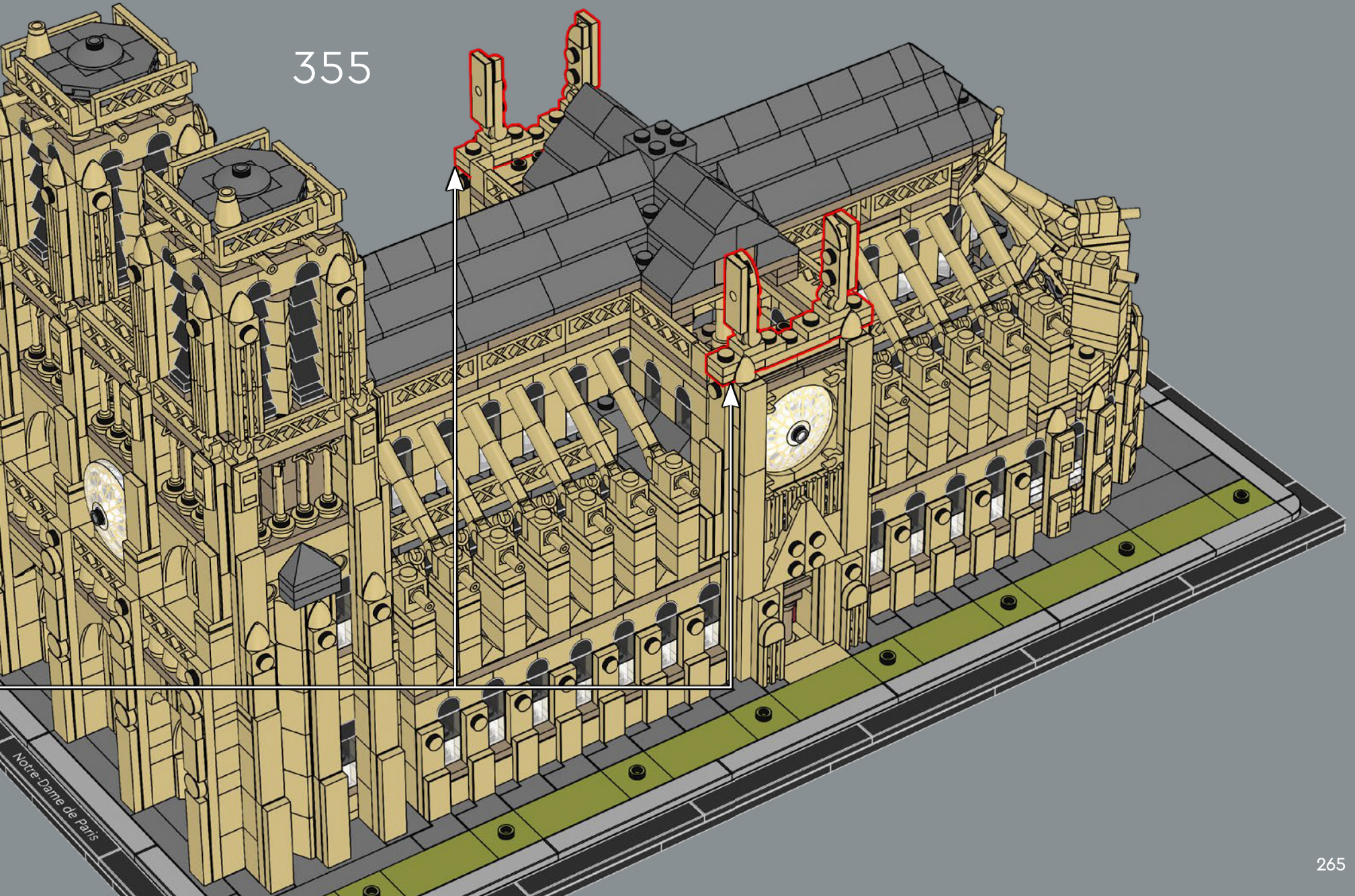

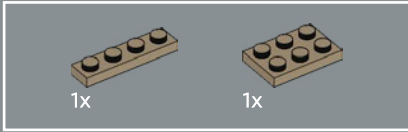

356

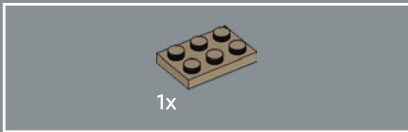
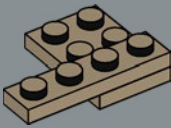

357

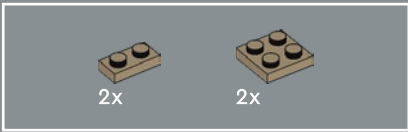
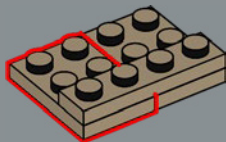

358

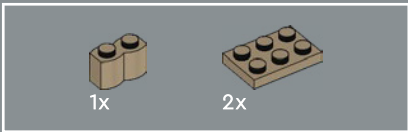
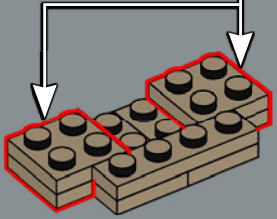
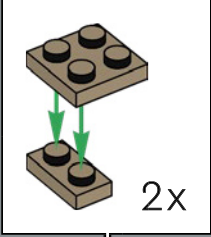

359

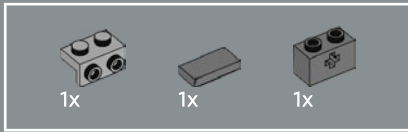
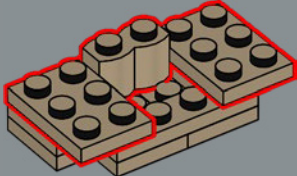

360

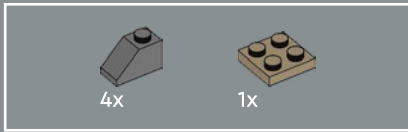
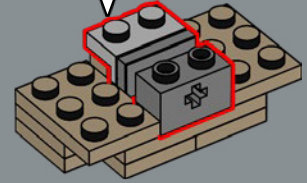
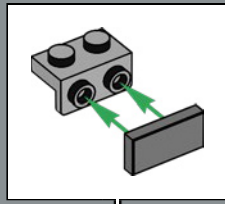

361

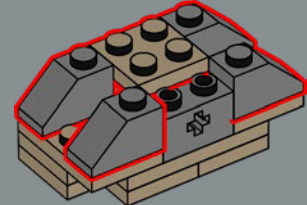

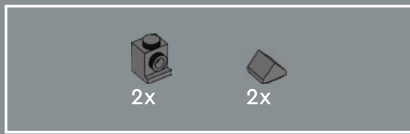

362

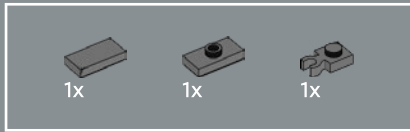
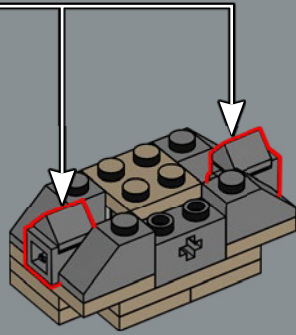
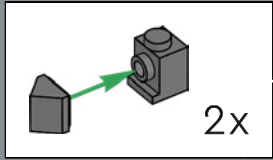

363

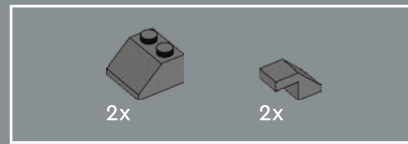
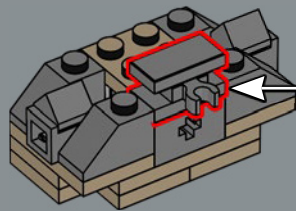
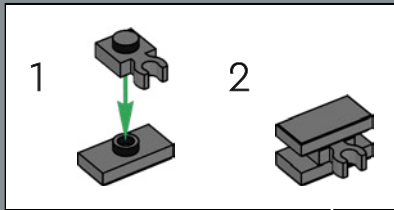

364

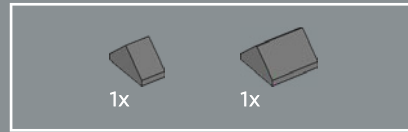
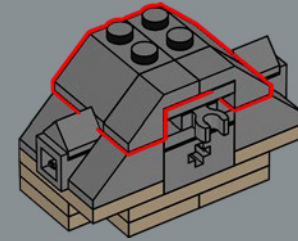

365

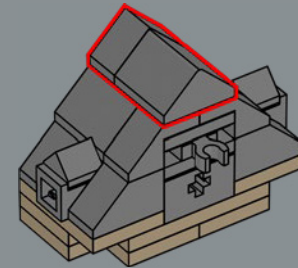



366

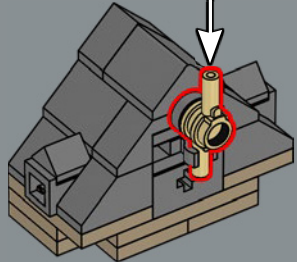
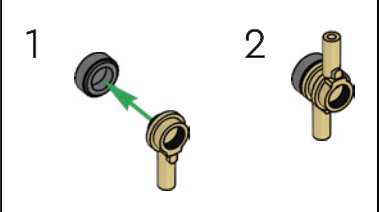

367

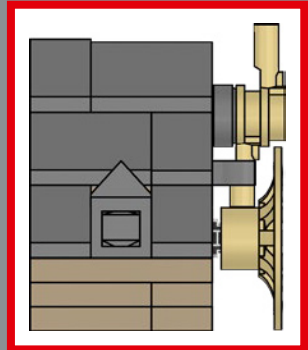
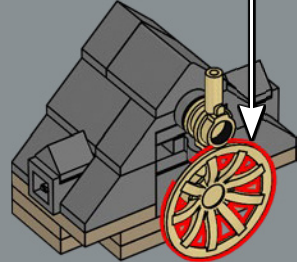
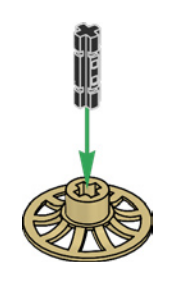

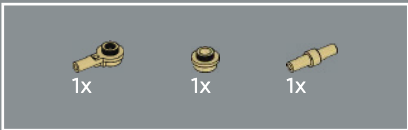

368

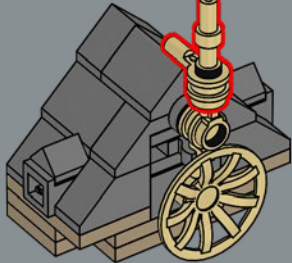
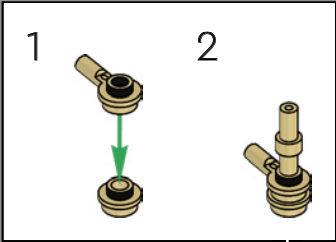

2x

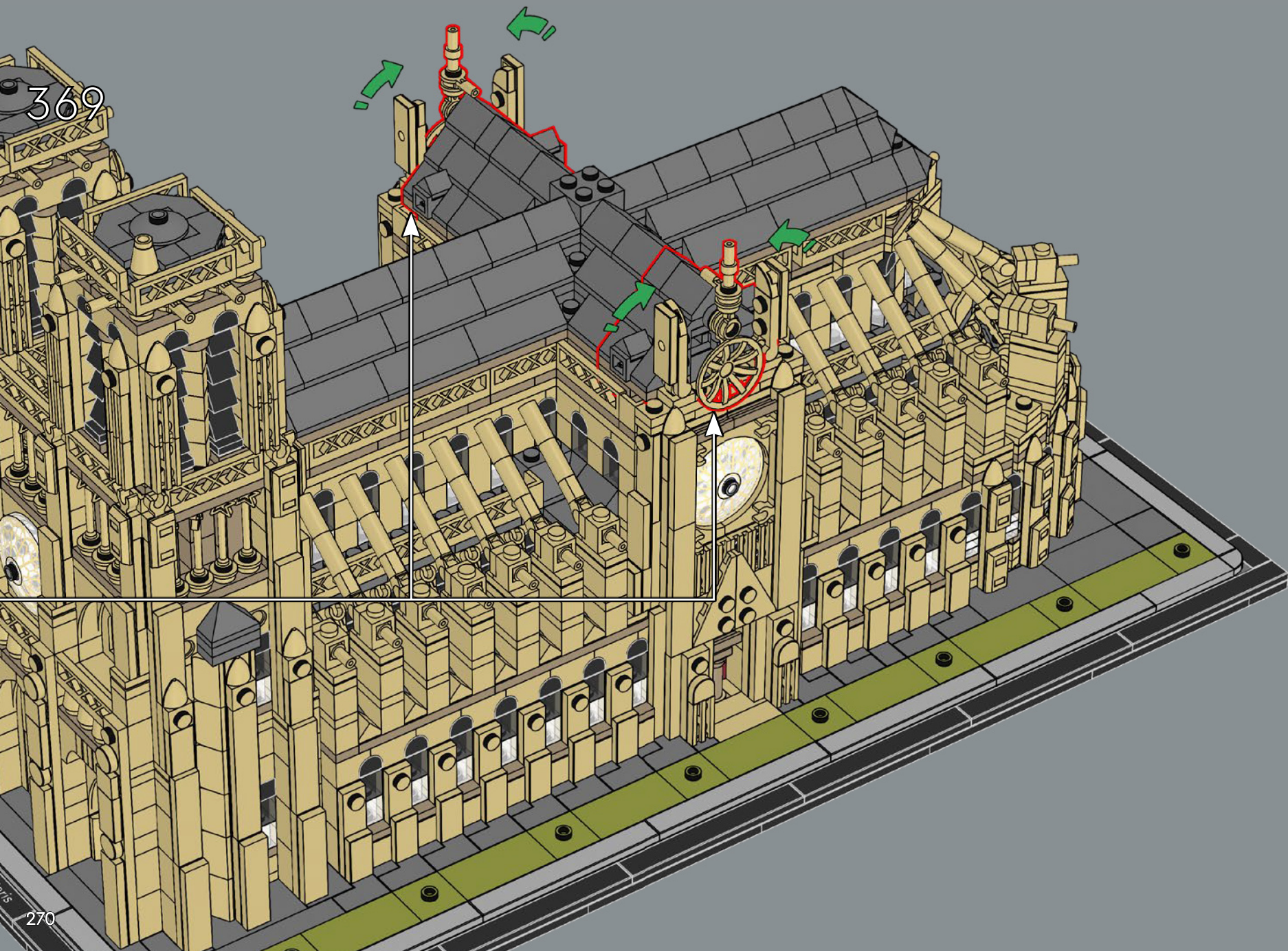

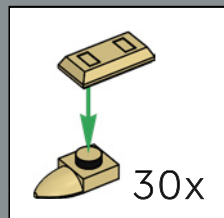
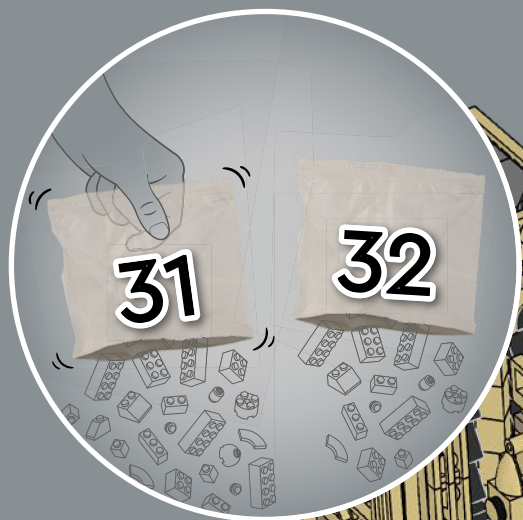

1789-1860 年

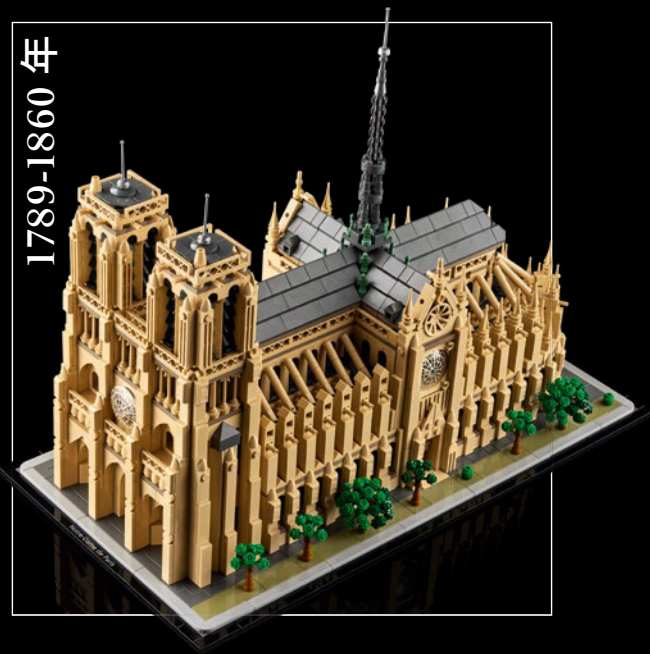

革命与文化遗产

✎ 在动荡的法国大革命（1789-1799 年）期间，高贵的巴黎圣母院遭受了破坏并逐渐破败。窗户、圣坛和坟墓被摧毁，钟被拆除并熔化。1792 年，暴徒推倒了国王画廊的雕像，并拆除了尖塔。有一段时间，巴黎圣母院甚至被用来储存葡萄酒和其它物品。但在大革命之后，随之而来的是对法国民族遗产的认识和欣赏。维克多·雨果的《巴黎圣母院》（1831 年）的出版和广泛国际赞誉巩固了巴黎圣母院作为世界历史上文化瑰宝的地位。从 1843 年到 1860 年，建筑师 Jean-Baptiste Lassus 和维欧勒·勒·杜克 (Eugene-Emmanuel Viollet-le-Duc) 主持巴黎圣母院的大规模修复活动，使其成为我们今天所知道的历史地标。



371

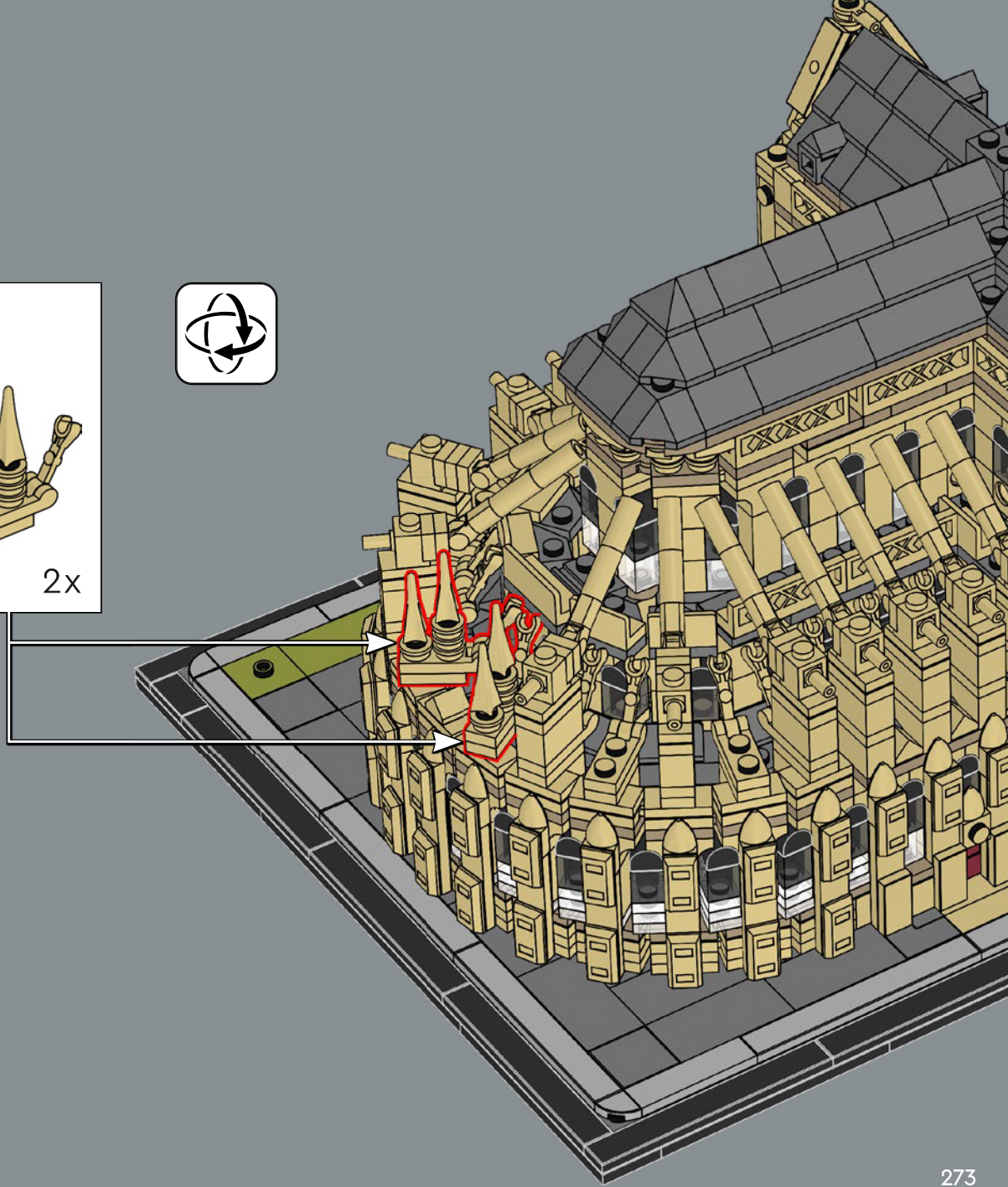
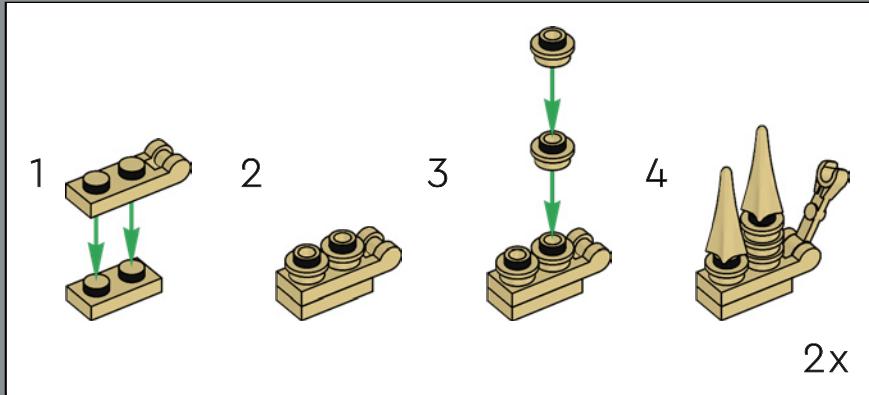



372

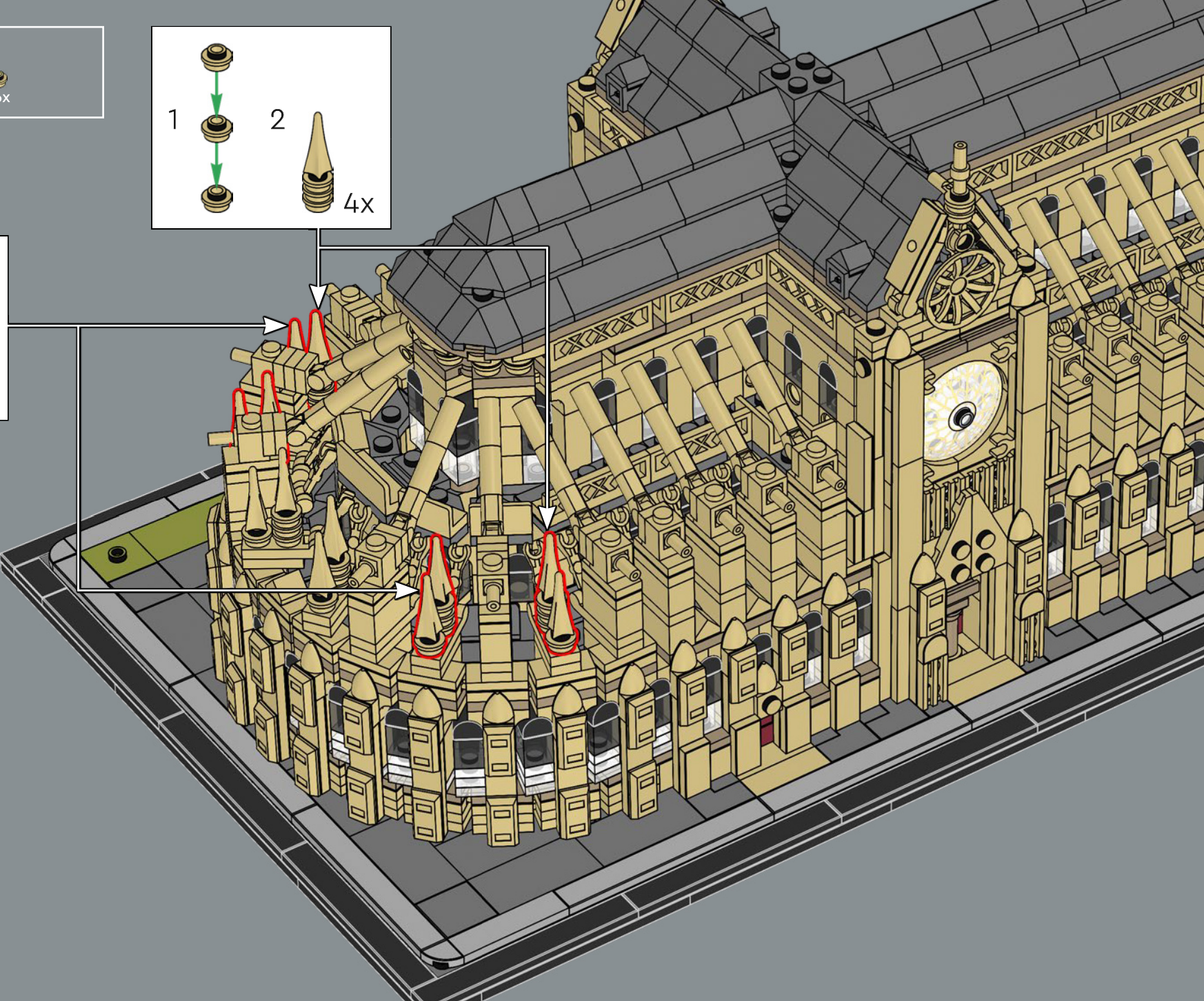
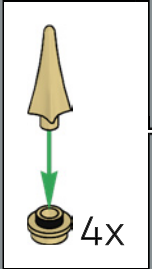
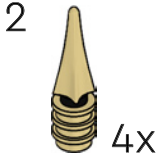
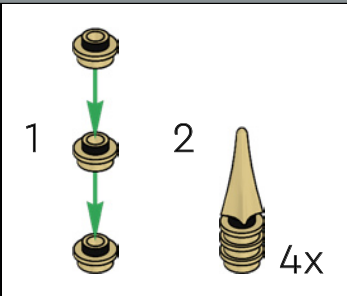



1350 年——巴黎圣母院的收尾工作完成;在 19 世纪再次被替换之前,飞扶壁立柱上的尖顶被重新制作。

373

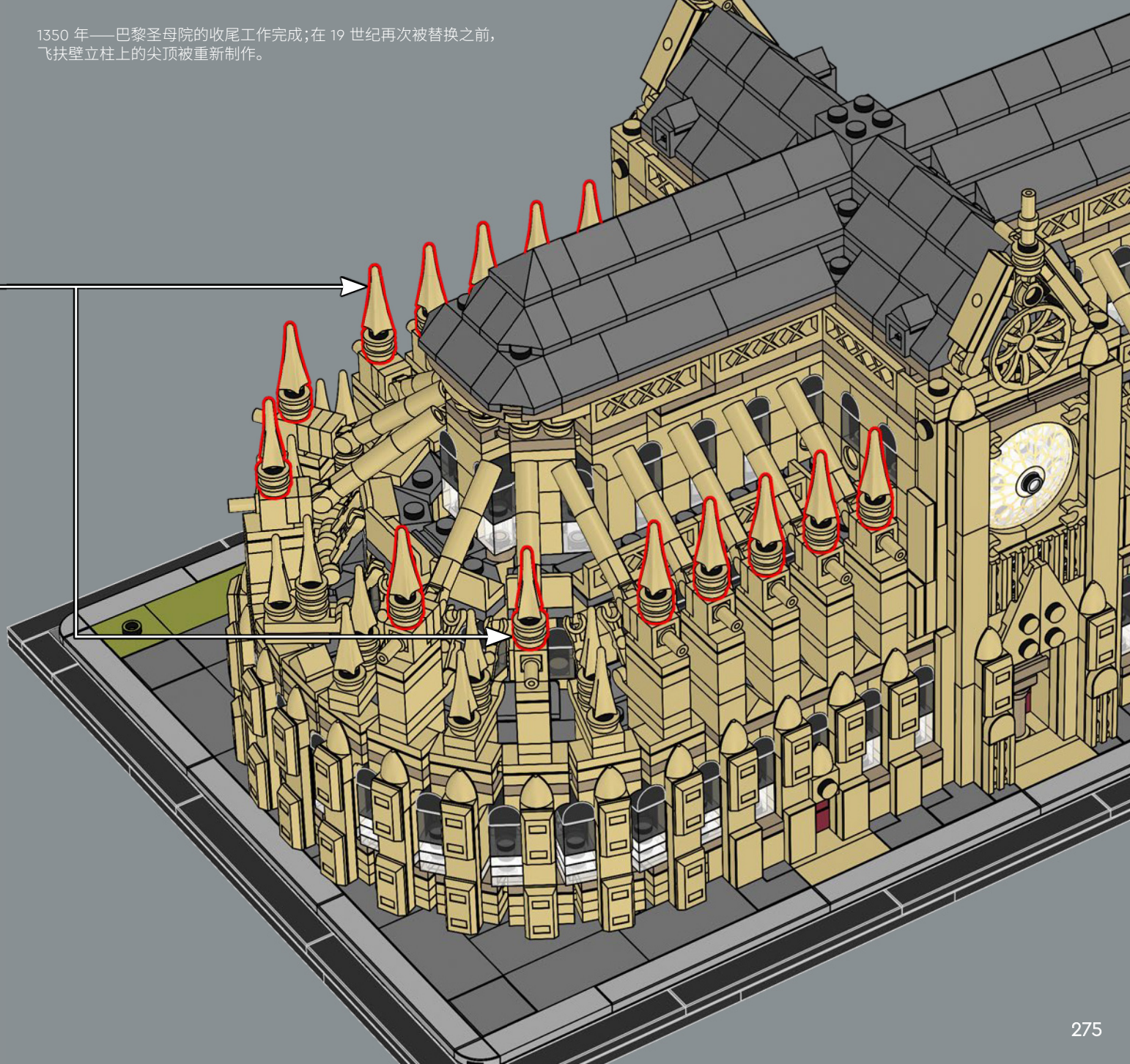
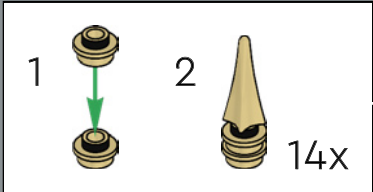



374

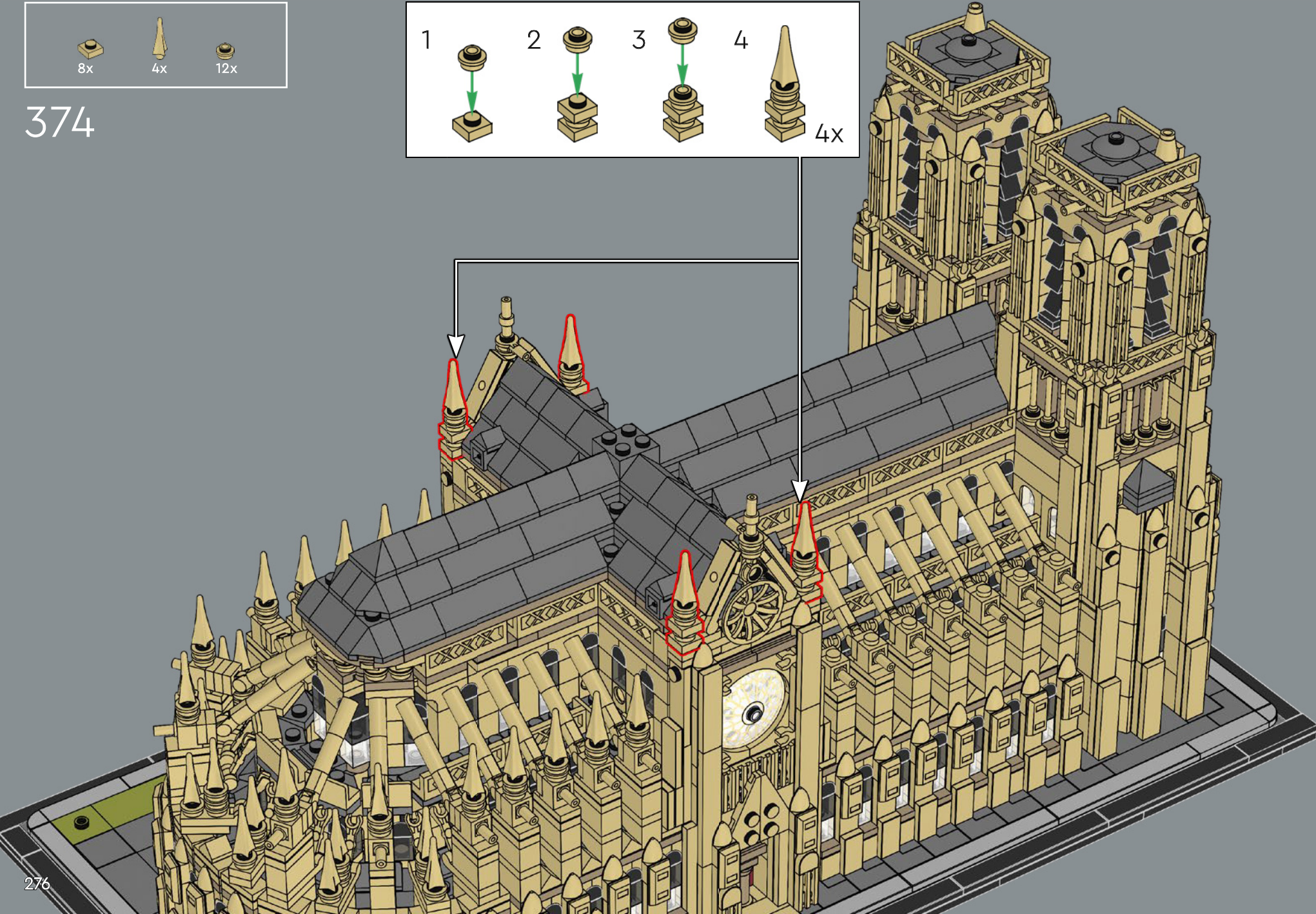
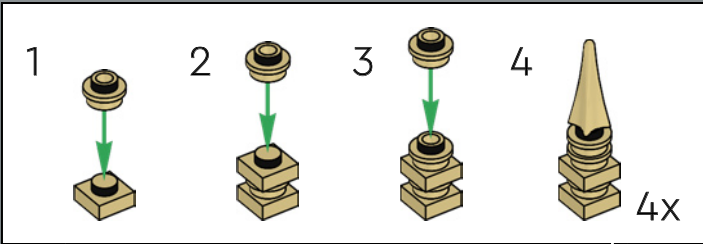



14x



14x

1858 年—— Jean-Baptiste Lassus
和维欧勒·勒·杜克增添了飞扶壁上的壁龛。

375



14x

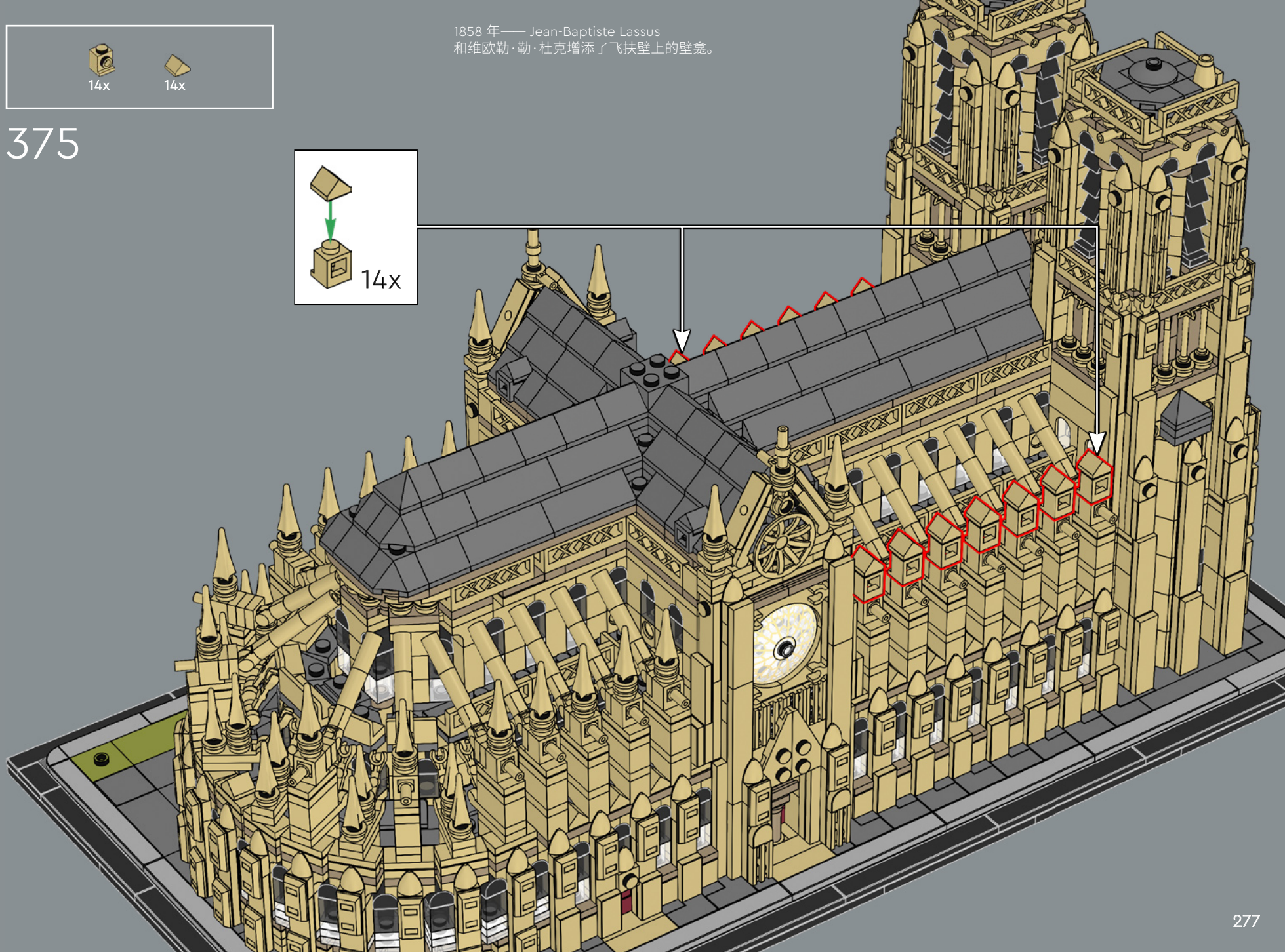

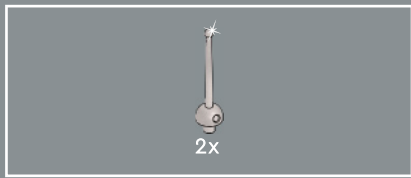

376

西立面的两座塔楼高 69 米 (226 英尺)，
使巴黎圣母院成为巴黎最高的建筑，
直到埃菲尔铁塔 (1887-1889 年) 建成。

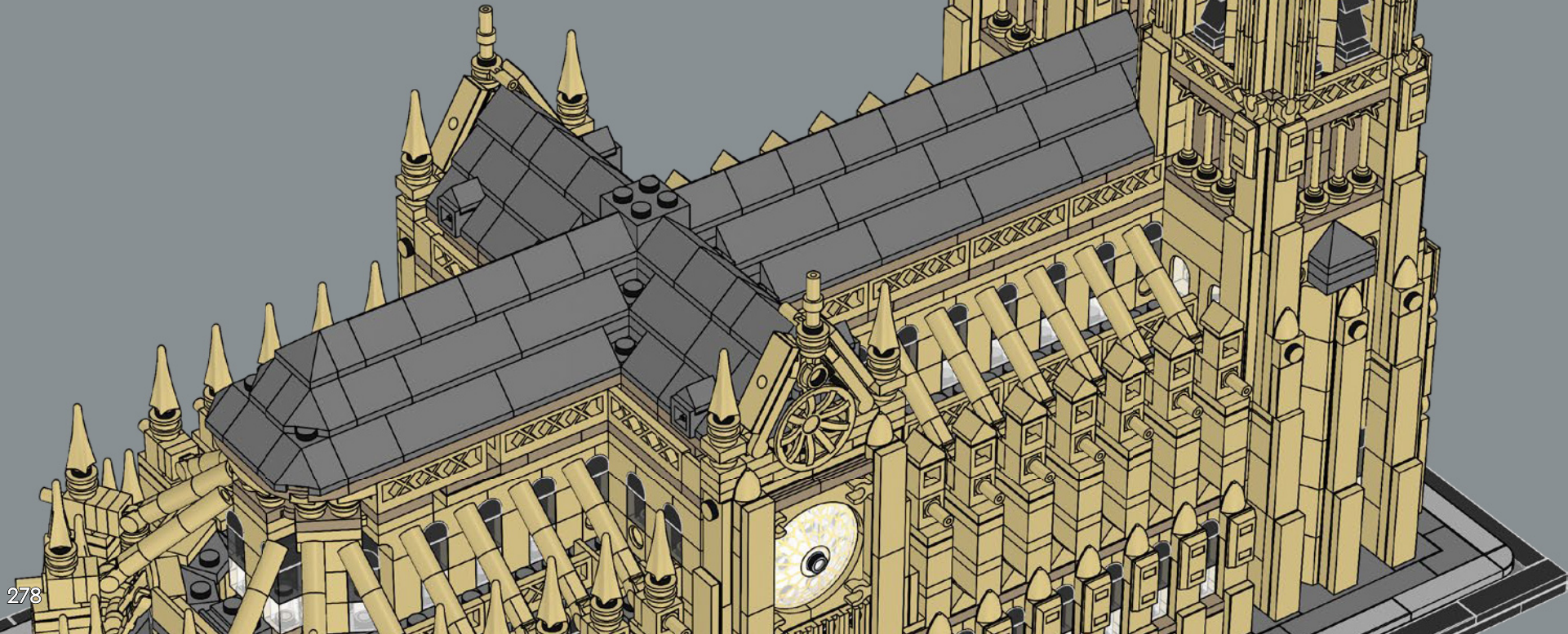



8x

377

1843-1860 年—— Jean-Baptiste Lassus
和维欧勒·勒·杜克主持重大修复工作。

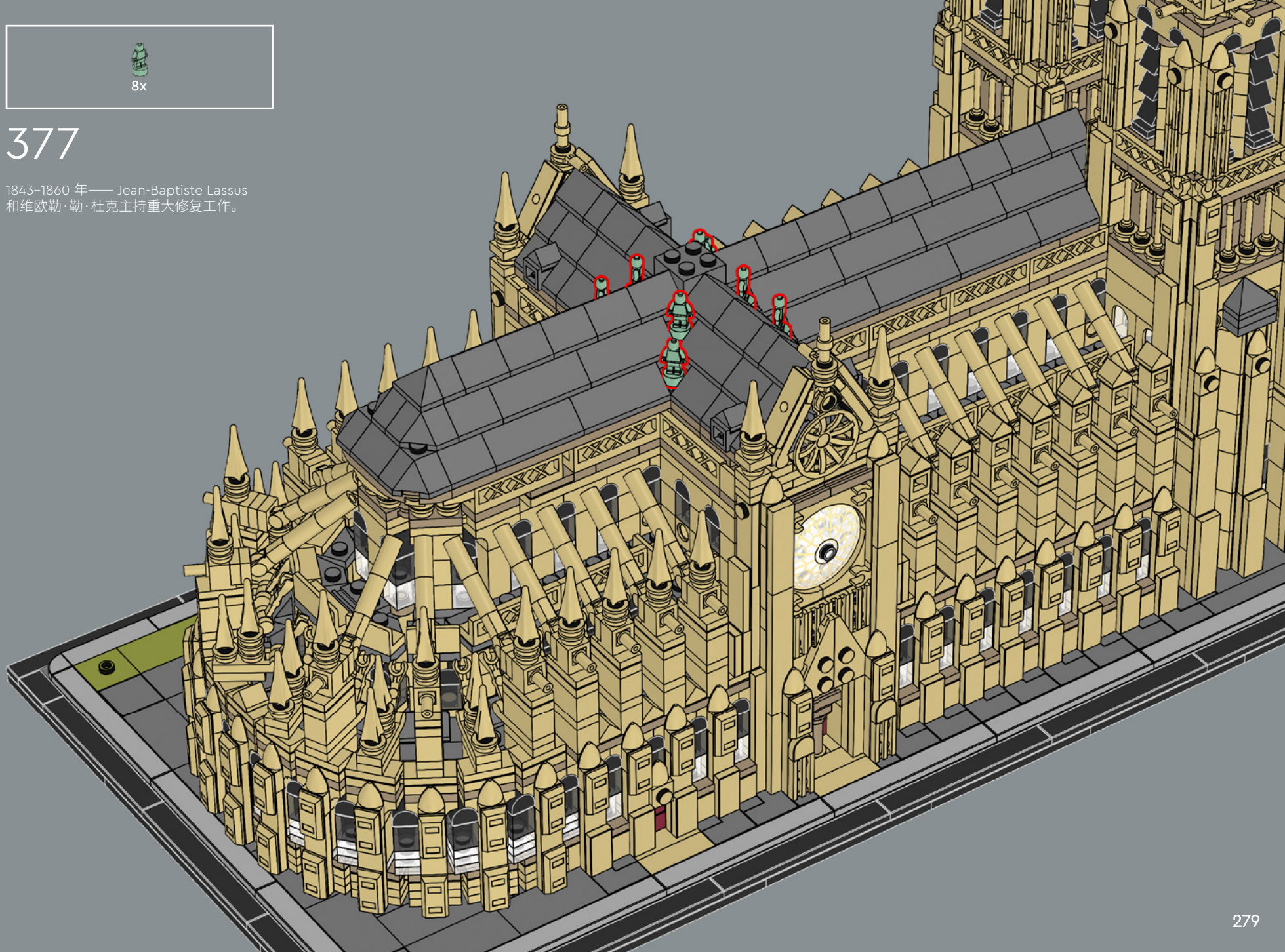



- 2x 
- 1x 
- 1x 
- 8x 

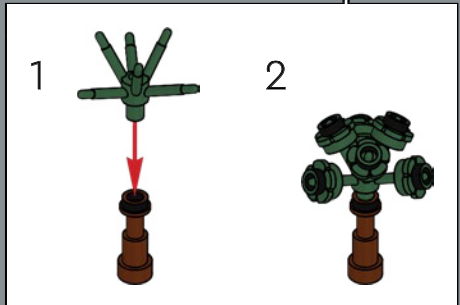
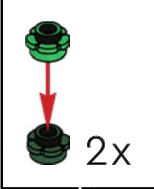

378





Notre-Dame de Paris

 18x
 3x
 3x

379



Notre-Dame de Paris

1 
 2 
 3x

巴黎圣母院当前规模:立面宽度:43.5 米(142.7 英尺)。
 耳堂宽度:48 米(157.5 英尺)。总长度:128 米(419.9 英尺)。
 尖塔高度:96 米(314.9 英尺)。塔楼高度:69 米(226 英尺)。
 中堂屋顶高度:35 米(114.8 英尺)。

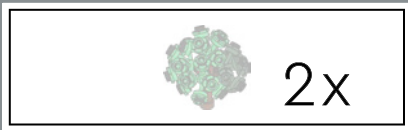

380

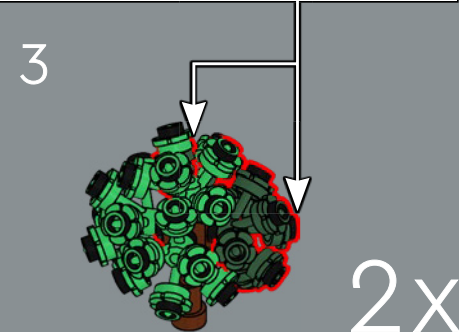
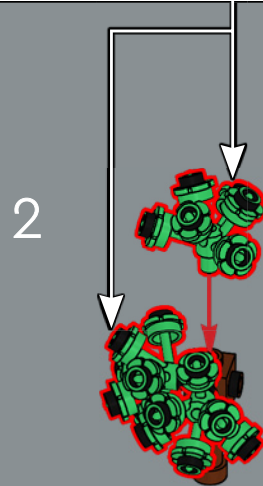
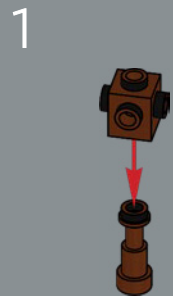
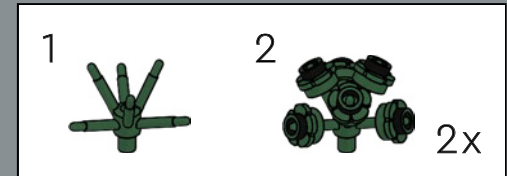
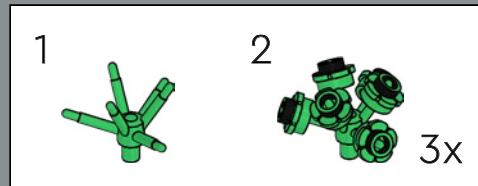

2x



Notre-Dame de Paris

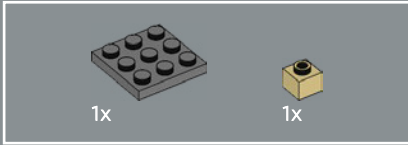
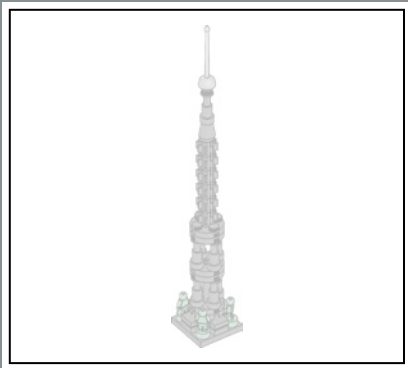

381

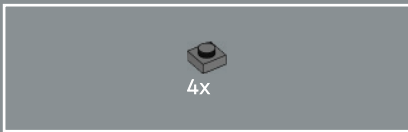
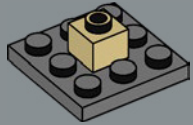

382

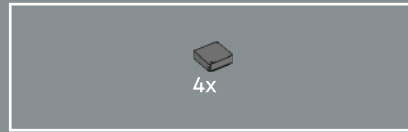
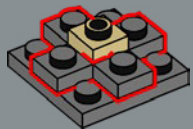

383

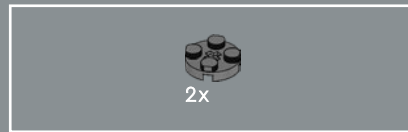
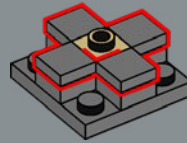

384

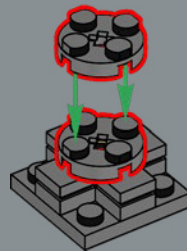

385

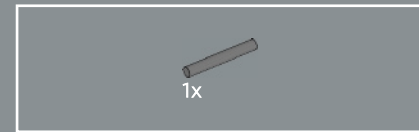
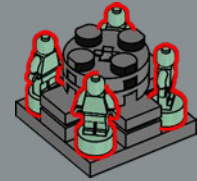

386

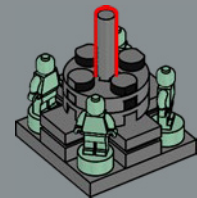



387

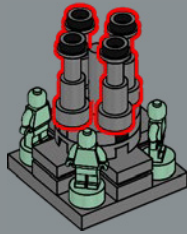

389

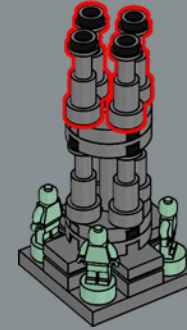

388

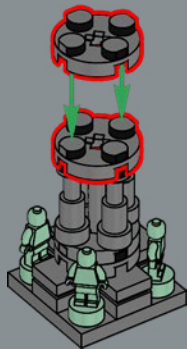

390

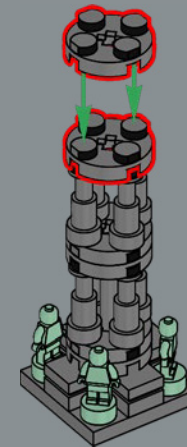

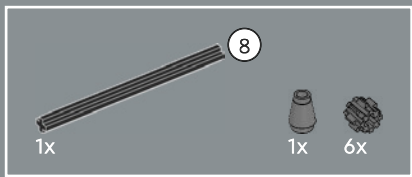

391

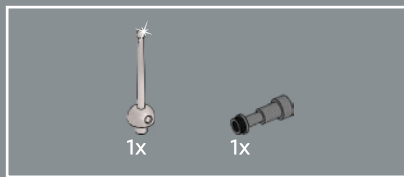
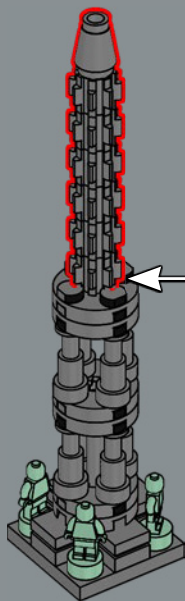
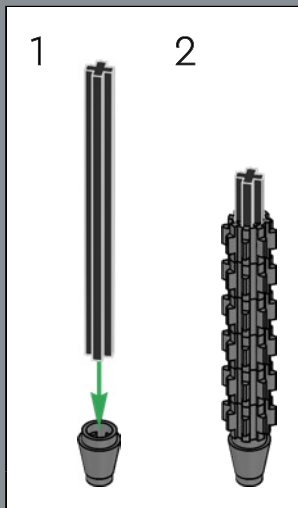

392

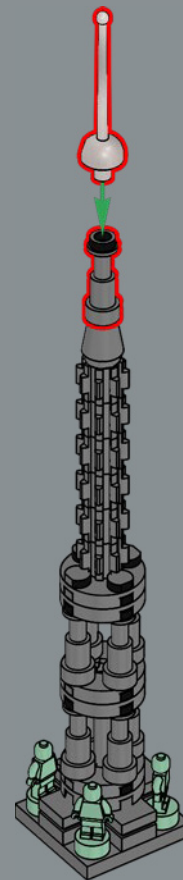

1860 年——重建尖塔，比原来更纤细、更高，并沿着屋顶的斜坡增加了 12 位使徒的雕塑。

乐高®巴黎圣母院的前门是敞开的,以便我们查看,并感受进入内部广阔且错综复杂的拱形空间时可能会体验到的敬畏感。

393

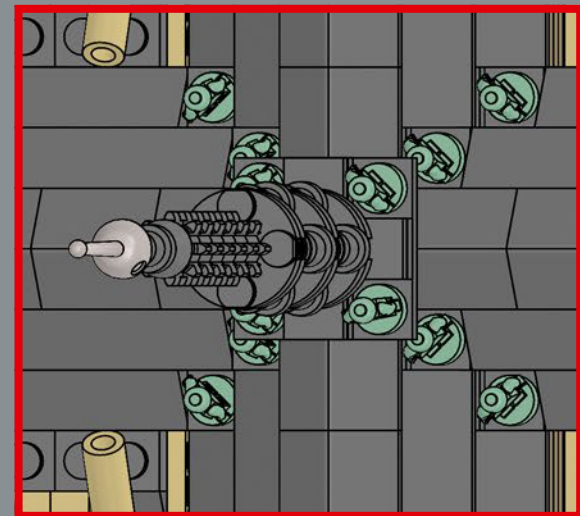
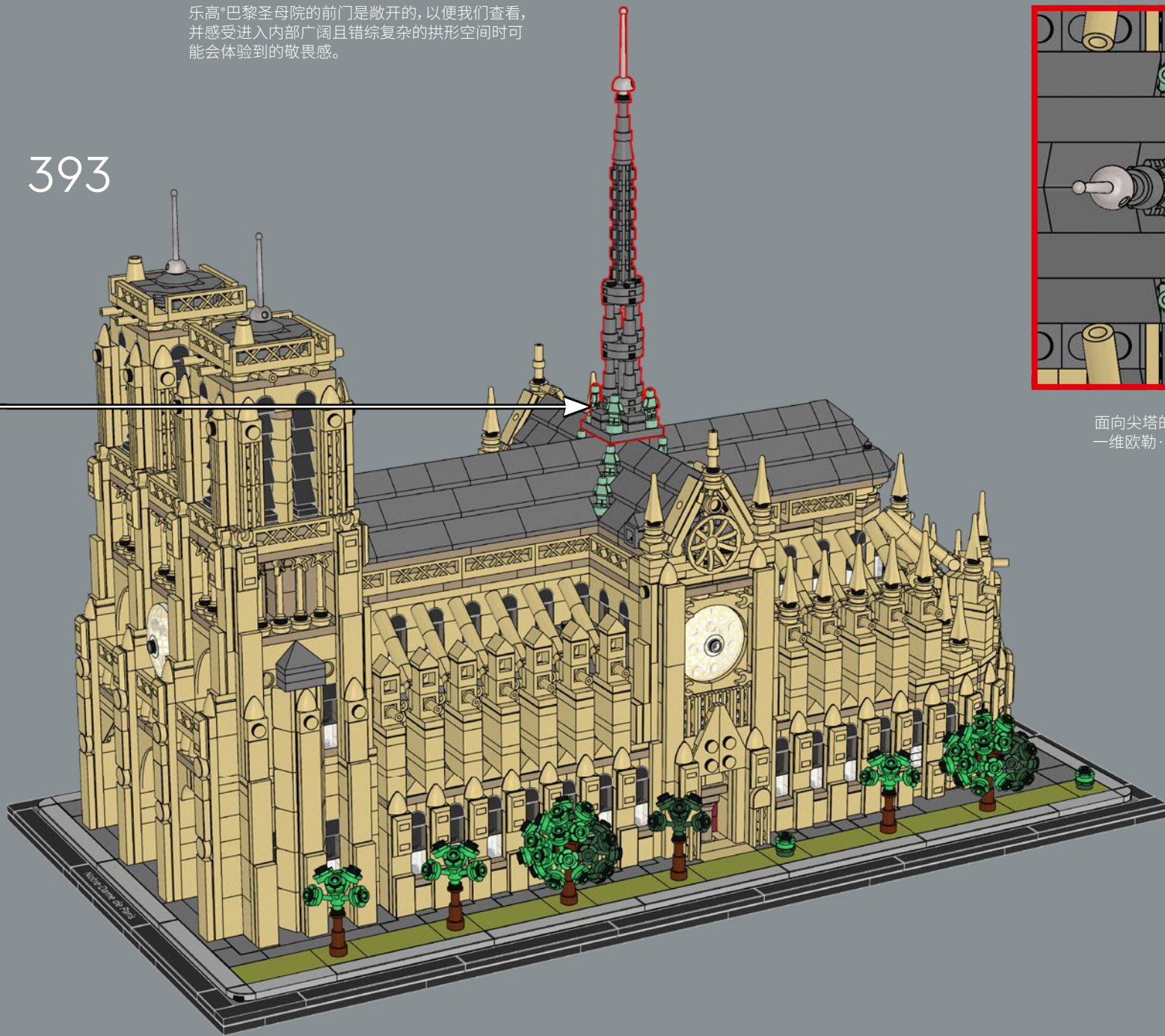

面向尖塔的唯一雕像上拥有巴黎圣母院建筑师之一维欧勒·勒·杜克的面部。他凝视着尖塔,欣赏着这座建筑,而其他人则注视着巴黎。



火灾与重建

在 2019 年 4 月的毁灭性大火之后，巴黎圣母院被迫无限期关闭，等待重建。全世界目睹了救援人员扑灭大火的情形，随即掀起筹款浪潮，在创纪录的时间内为大规模的重建工作筹集了巨额捐款。这证明了巴黎圣母院在其整个生命周期中为所有文化背景的人们留下了永久的印象，以及无与伦比的巴黎精神。我们很高兴将这款模型纳入我们的乐高建筑系列，它将近 900 年的历史融入到超过 4000 块乐高®积木组件中。





6x
4616711



80x
6300322



8x
6231386



12x
6449564



1x
6167854



2x
6300321



8x
6458397



32x
6446790



5x
6398343



5x
6264025



1x
6341471



2x
6133765



7x
6428178



6x
6310449



1x
4211389



2x
6267495



6x
4211511



2x
4213567



6x
6383177



4x
6401023



4x
4211356



6x
4211445



16x
4211481



2x
4654582



2x
6469440



4x
6176433



12x
6335936



4x
4211098



1x
4211088



3x
4211060



1x
4211085



4x
4211044



4x
4558955



18x
4535930



22x
4211127



12x
4210848



4x
4210719



9x
4211063



14x
4211052



14x
6092572



16x
4210635



2x
6126083



2x
6309059



6x
6177079



10x
4211094



2x
4211055



31x
6247784



31x
6343852



4x
4568734



1x
4211133



12x
4211043



2x
4211053



19x
6039176



4x
6307616



19x
4560184



5x
42110651



1x
4243831



2x
4210998



1x
4211115



1x
4211134



2x
6296892



1x
4543086



9x
6284596



2x
4210633



4x
6221607



3x
4210872



3x
4210869



6x
4211042



2x
4211010



10x
6164073



2x
4527082



1x
6310596



9x
6396412



6x
6012451



20x
4211045



6x
4218188



2x
4210678



20x
4211114



3x
6222063



8x
6212080



8x
6016488



86x
6470140



24x
6446336



[LEGO.com/service](https://www.lego.com/service)



YOU COULD WIN



YOU COULD WIN

Your feedback will help shape the future development of this product series.

Visit:

DU KÖNNTEST GEWINNEN

Dein Feedback trägt zur Weiterentwicklung dieser Produktreihe bei.

Geh auf:

VOUS POURRIEZ GAGNER

Vos commentaires nous aideront à concevoir les futurs produits de cette gamme.

Visitez :

POTRESTI VINCERE TU

La tua opinione ci aiuterà a migliorare la creazione futura di questa linea di prodotti.

Visita:

PUEDES GANAR

Tu opinión contribuirá al futuro de esta serie de productos.

Visita:

轻松获奖

您的反馈将有助于我们在今后改进本产品系列。

请访问:

LEGO.com/productfeedback

You also have the chance to win a LEGO® set.

Terms and conditions apply.*

Außerdem hast du die Chance, ein LEGO® Set zu gewinnen.

Es gelten die Teilnahmebedingungen.*

Vous pourriez également gagner un ensemble LEGO®.

Des conditions s'appliquent.*

Hai anche la possibilità di vincere un set LEGO®.

Termini e condizioni sono applicabili.*

También tienes la oportunidad de ganar un set LEGO®.

Aplican términos y condiciones.*

您还有机会赢取乐高®套装。

条款和条件适用。*

*LEGO.com/productfeedback-terms

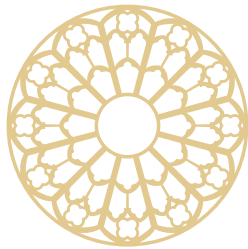

LEGO and the LEGO logo are trademarks of the LEGO Group. ©2024 The LEGO Group.
Adam Reed Tucker is the co-developer of the LEGO® Architecture product line.