



21061





[LEGO.com/sustainable-packaging](https://LEGO.com/sustainable-packaging)



FR  
**DONNEZ  
OU  
RECYCLEZ**



ASSOCIATION

OU



MAGASIN

OU



DÉCHÈTERIE

Adresses sur [quefairedemesdechets.fr](https://quefairedemesdechets.fr)



# BUILDER



Apple and the Apple logo are trademarks of Apple Inc., registered in the U.S. and other countries and regions. App Store is a service mark of Apple Inc. Google Play and the Google Play logo are trademarks of Google LLC. Tencent and the Tencent logo are trademarks of Tencent Inc.

LEGO.com/devicecheck



LEGO® Builder



# NOTRE-DAME DE PARIS

☞ "È difficile immaginare Parigi senza la maestosa cattedrale di Notre-Dame. Nel corso dei secoli, questo spettacolare landmark parigino ha resistito agli elementi, alla rivoluzione e a devastanti distruzioni, ma rimane ancorà oggi una delle attrazioni turistiche più popolari della capitale francese. Quando vediamo l'edificio in tutto il suo splendore, che sembra sfidare la gravità, potremmo chiederci come architetti, scalpellini e muratori abbiano creato un monumento così incredibile, la cui costruzione fu avviata quasi 900 anni fa e proseguì per diversi secoli. Ispirati e stupiti dalle tecniche ingegnose utilizzate da questi artigiani, abbiamo deciso di 'tradurre' questa magnifica costruzione e i suoi intricati dettagli in un modello LEGO®".

"Queste istruzioni vi guideranno attraverso il processo di costruzione, con ogni mattoncino posizionato con cura perché corrisponda a uno specifico elemento architettonico della cattedrale originale. Con ogni busta completata, si avrà un modello di un momento specifico nella costruzione della cattedrale, dal 1163 fino a oggi".

*Rok Žgalin Kobe, Senior LEGO® Designer*

1163-1182

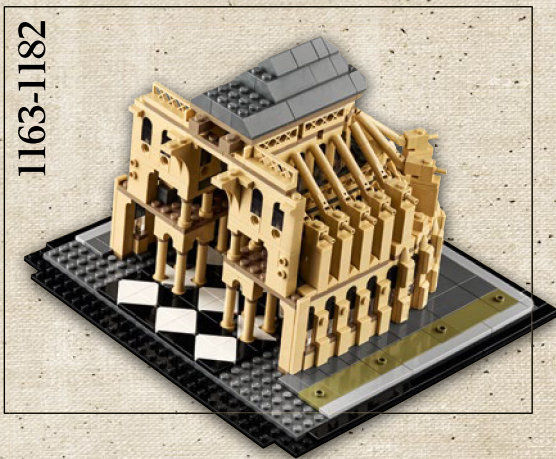

*1163-1182: il lato est della cattedrale fu completato per primo e rivestì la funzione di chiesa mentre le sezioni rimanenti della cattedrale venivano costruite.*

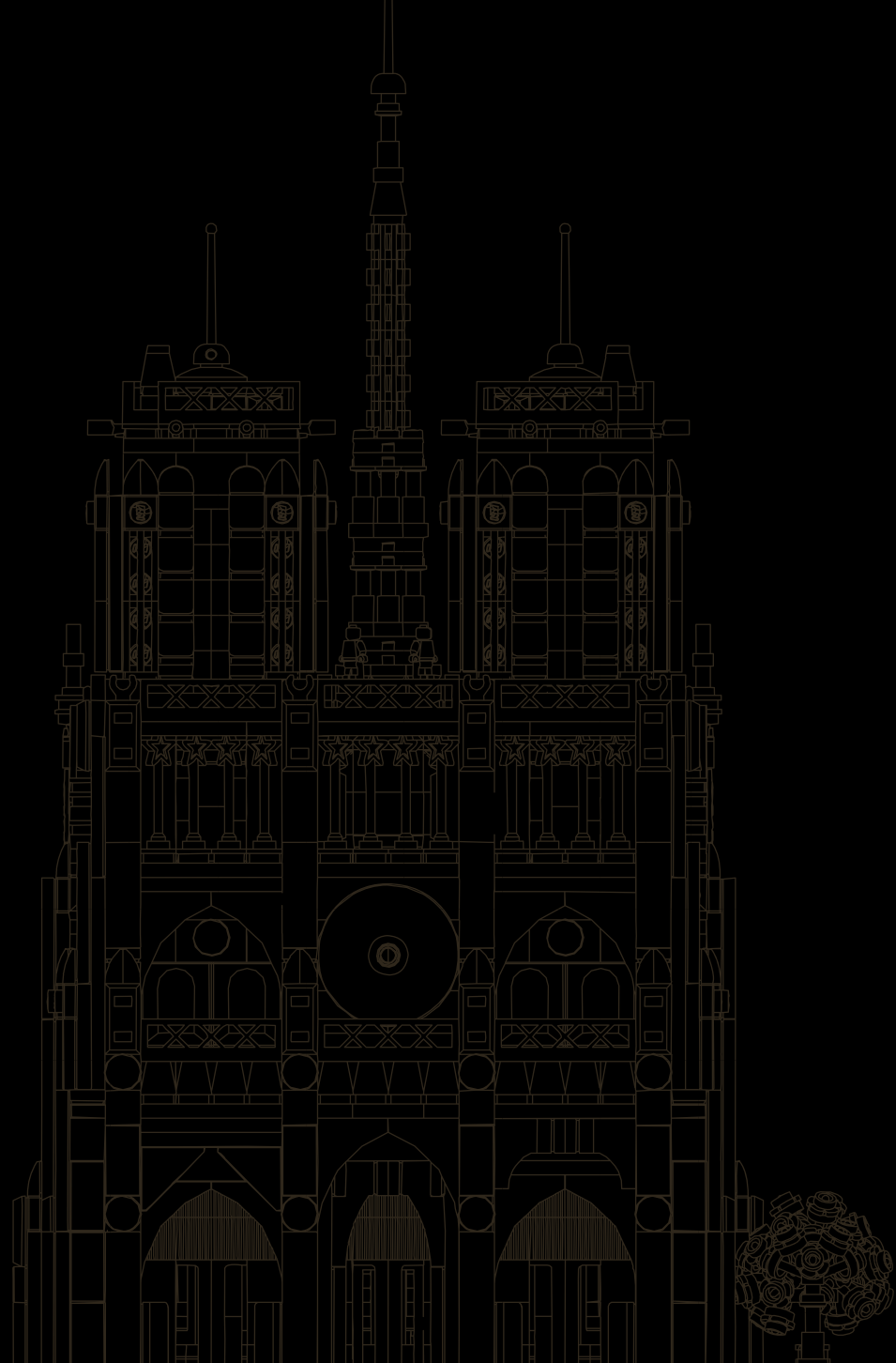

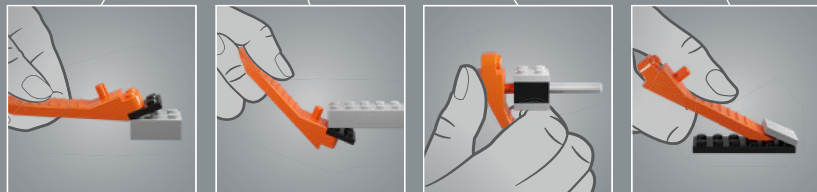
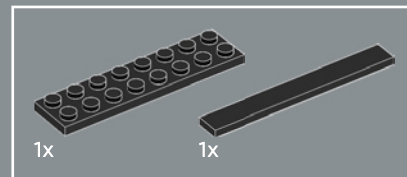
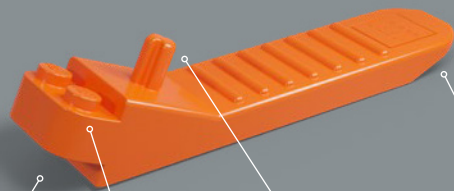

1

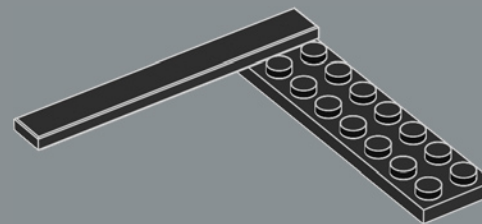

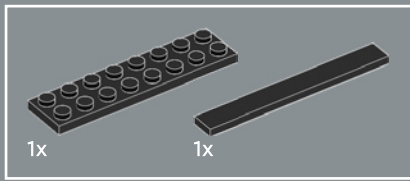

2

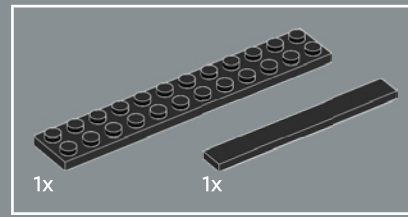
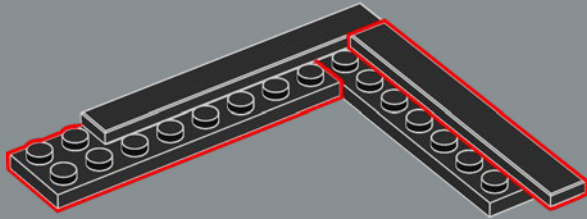

3

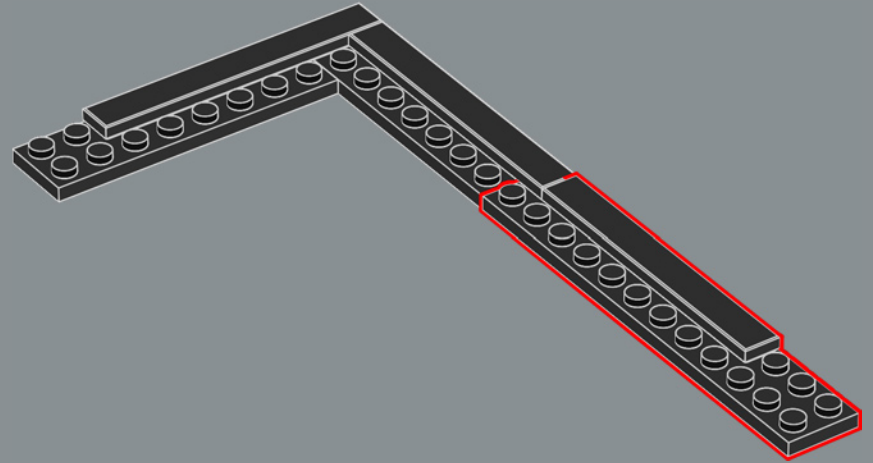

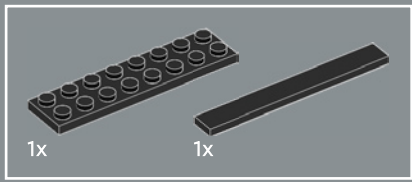

4

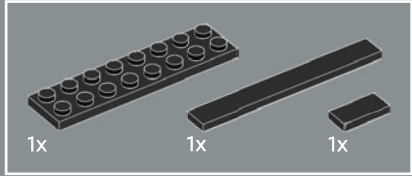
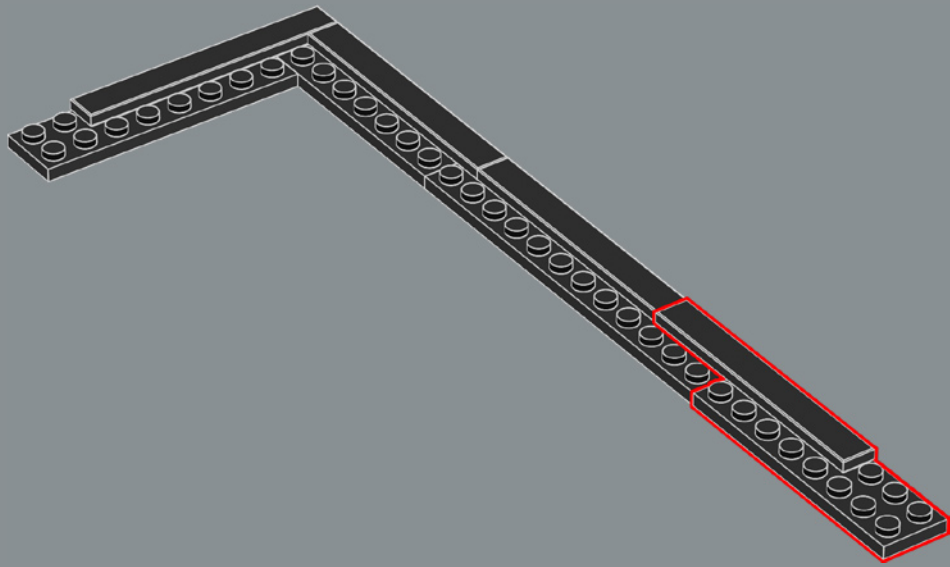

5

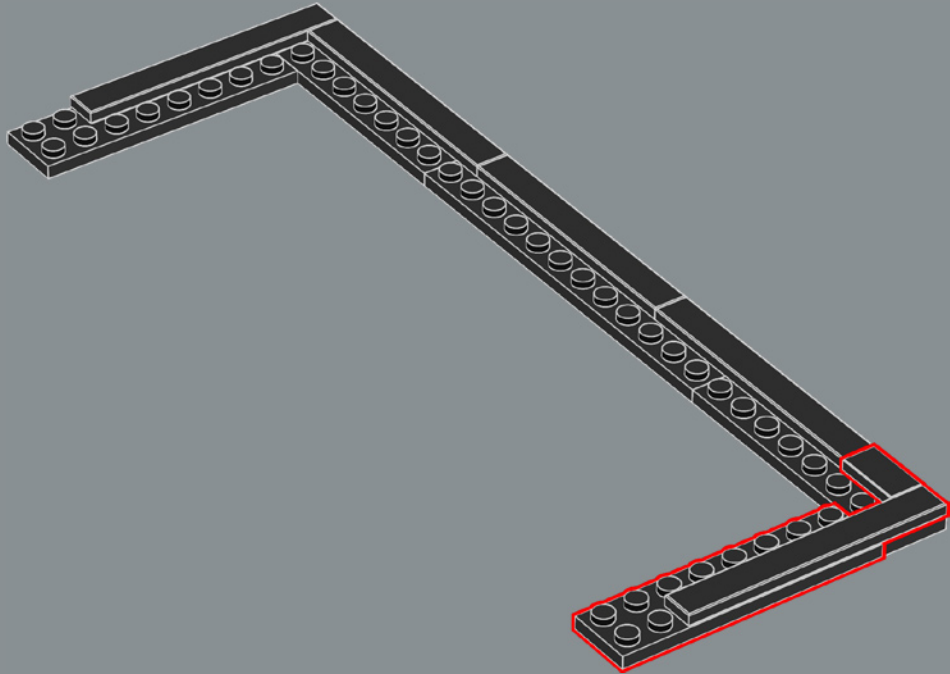

8



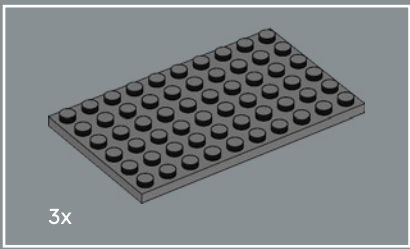

6

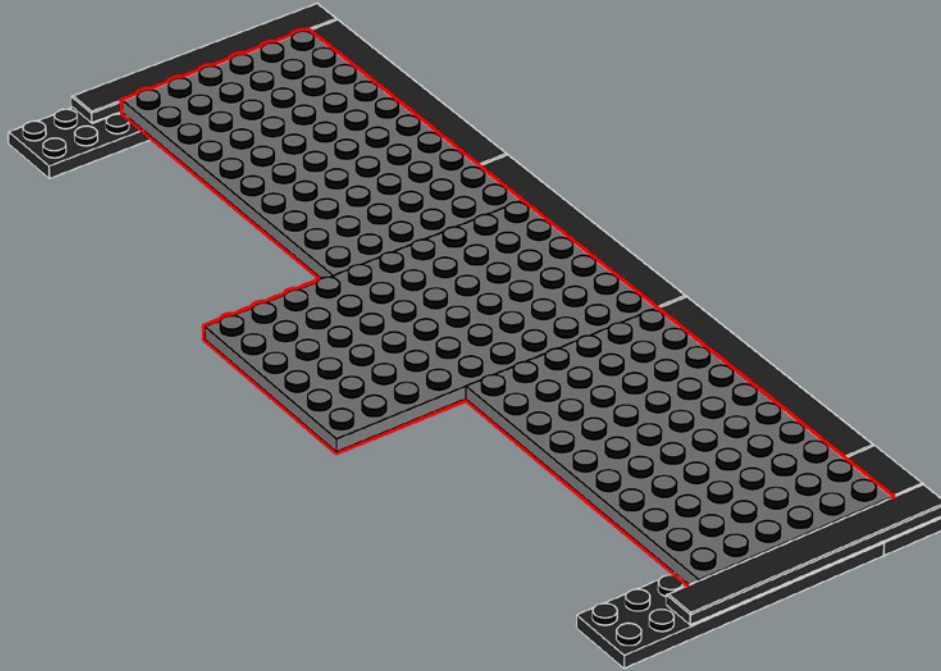

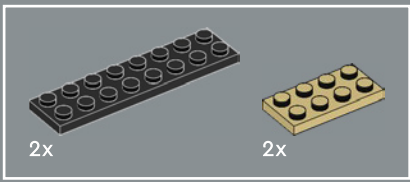

7

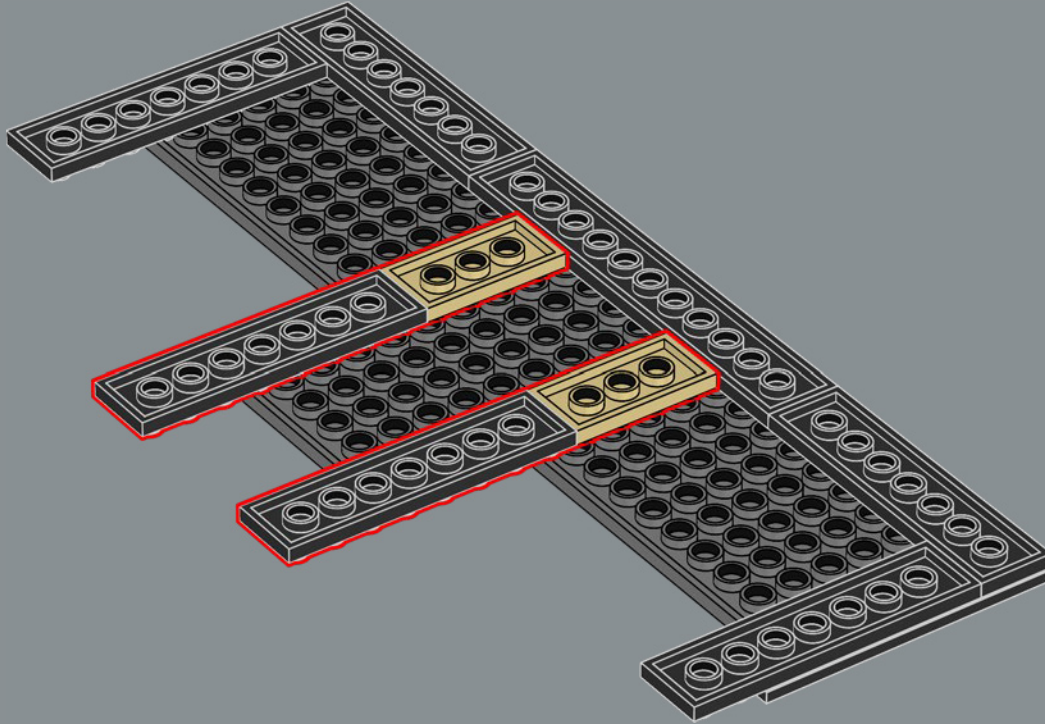

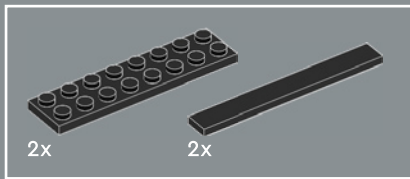

8

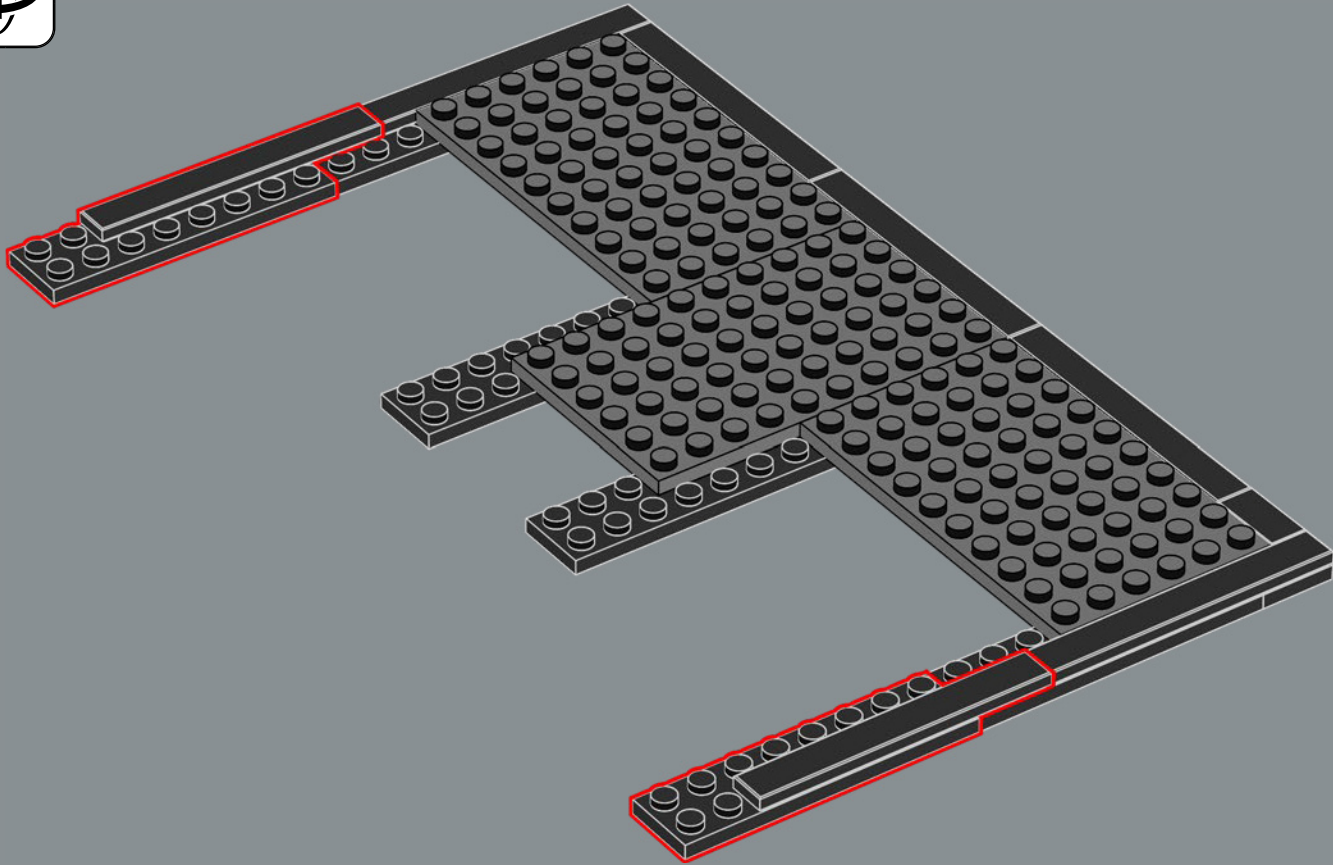

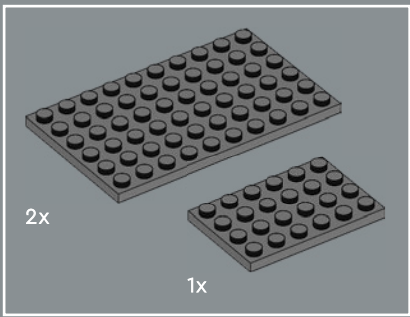

9

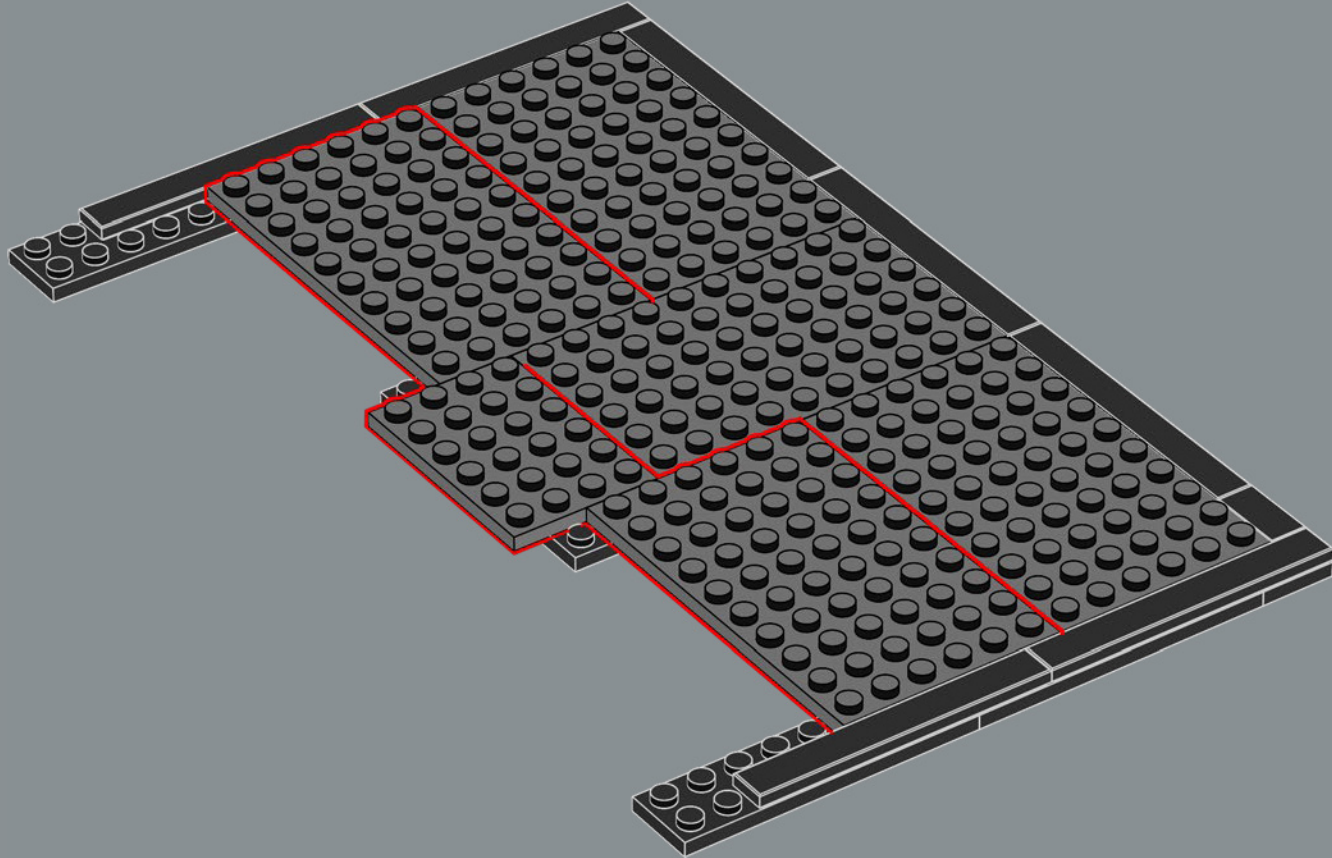

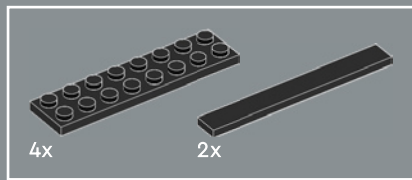

10

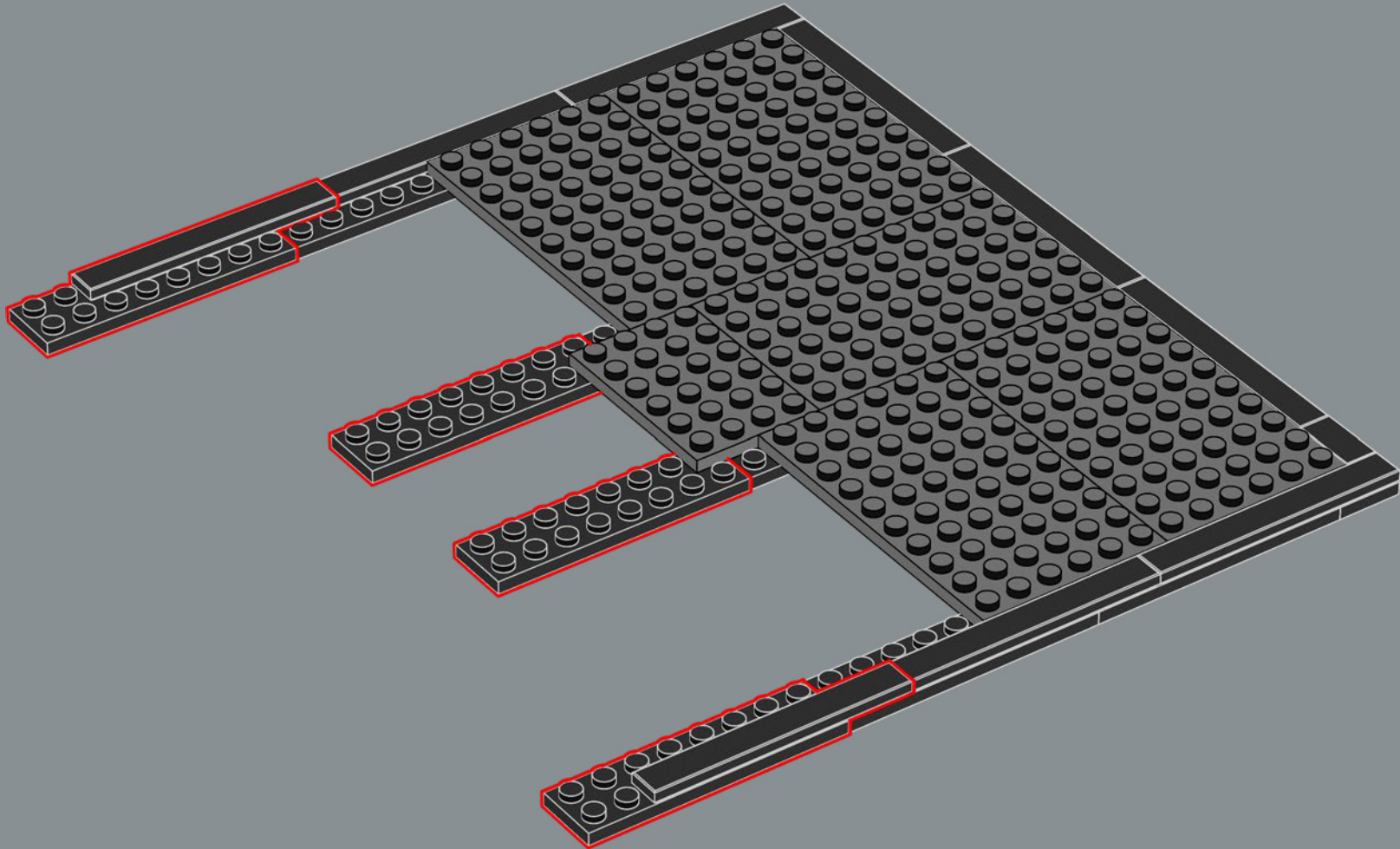



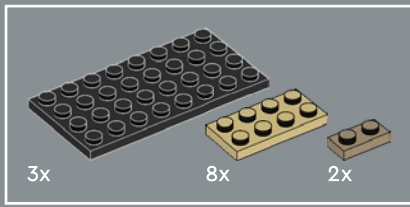

12

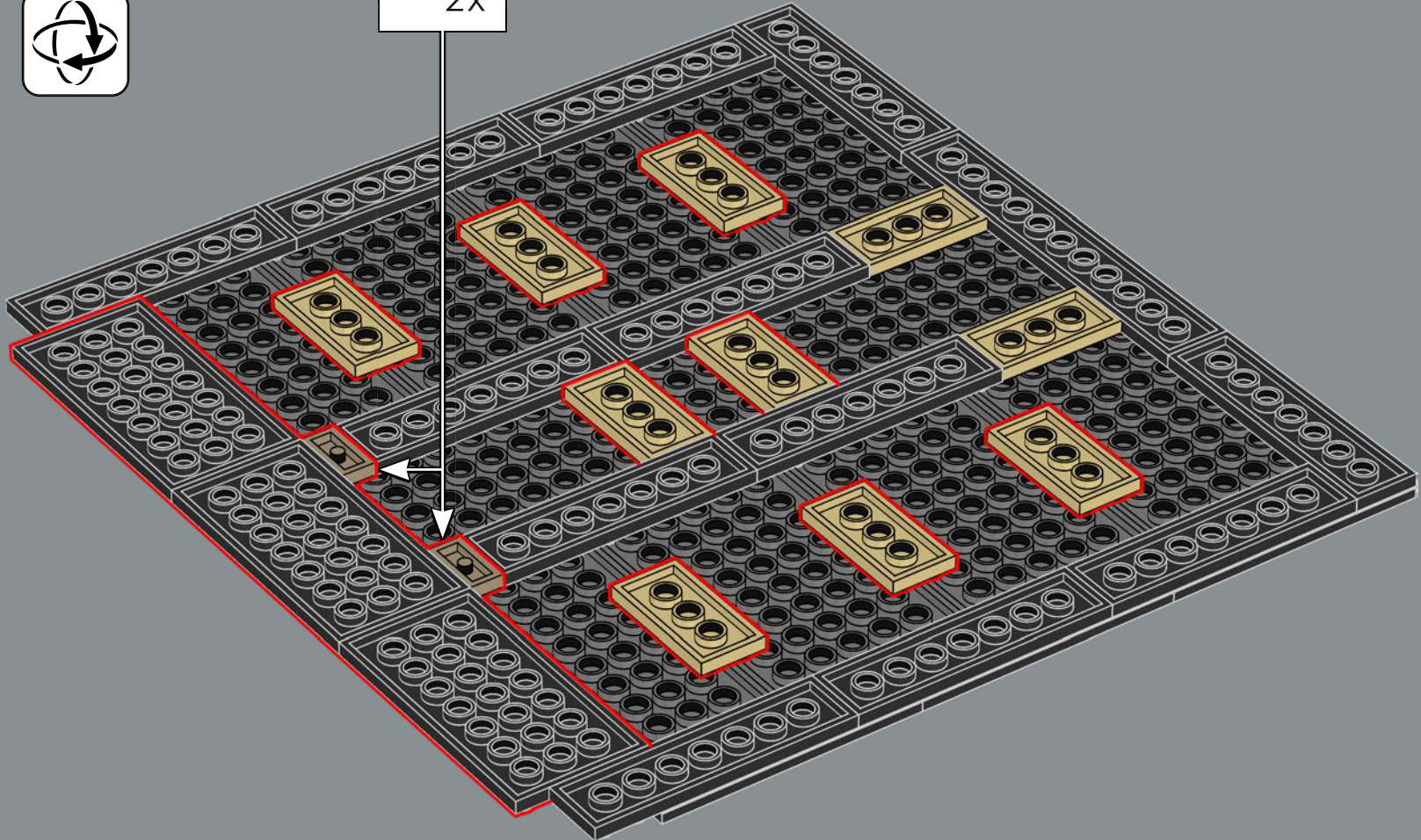
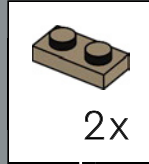

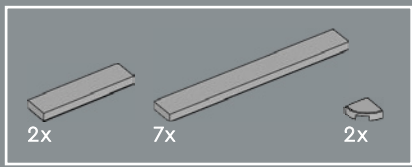

13

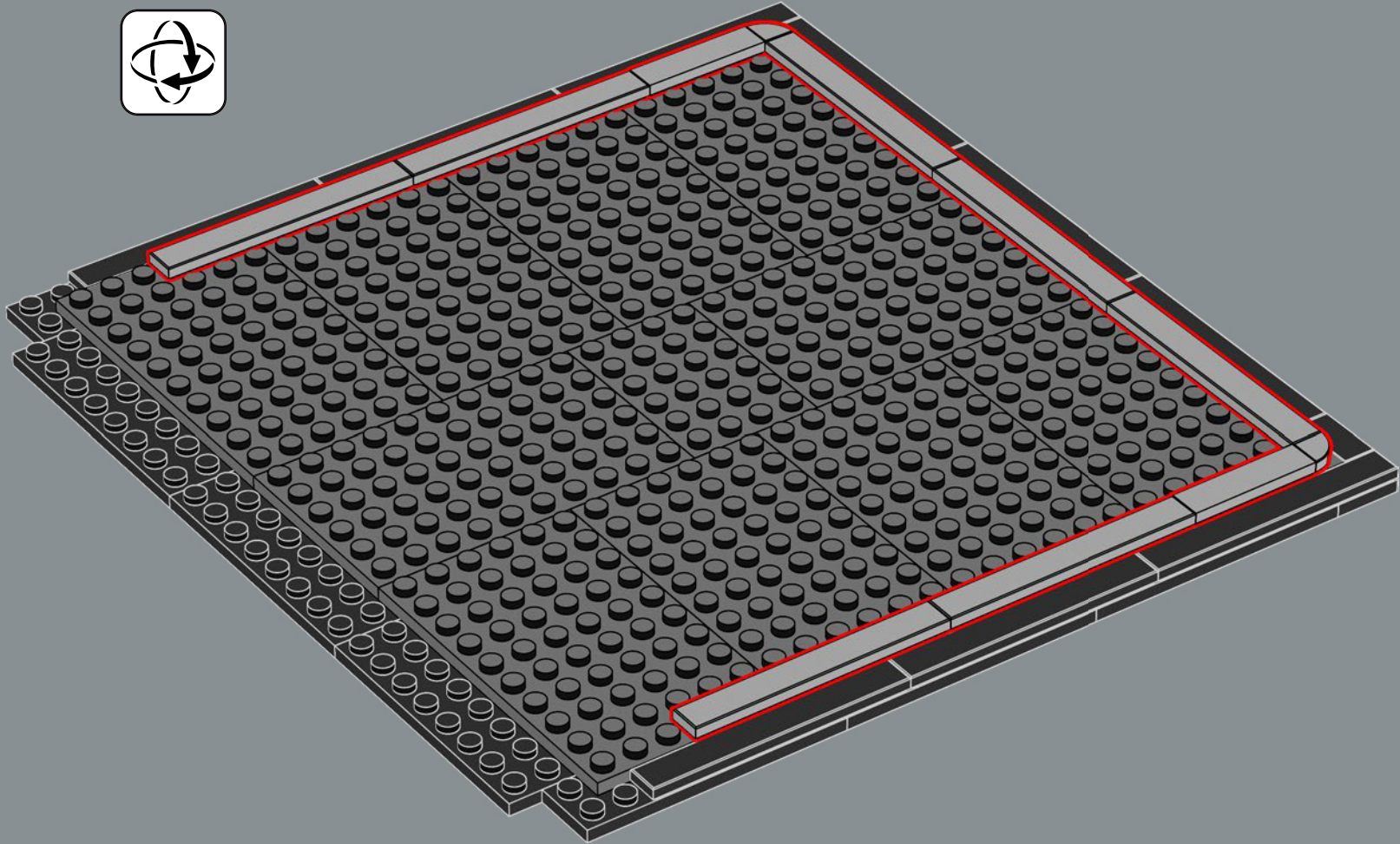



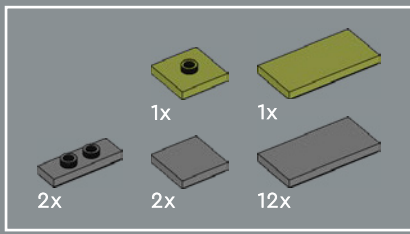

14

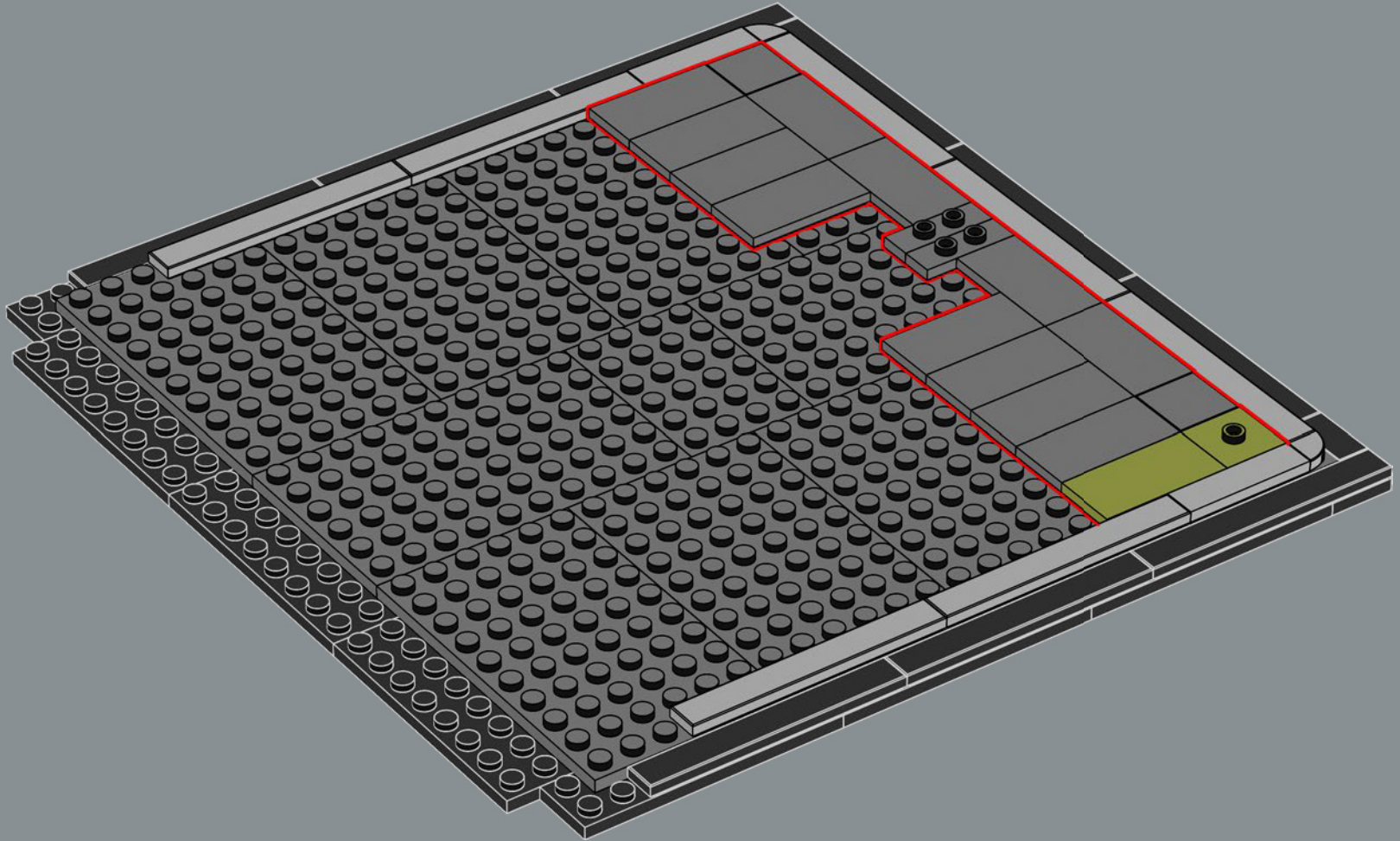

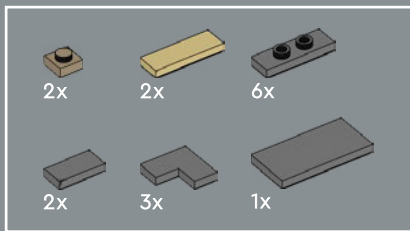

1163 - I progetti per la cattedrale di Notre-Dame sono pronti. Inizia la costruzione e Papa Alessandro III assiste alla posa della prima pietra.

15

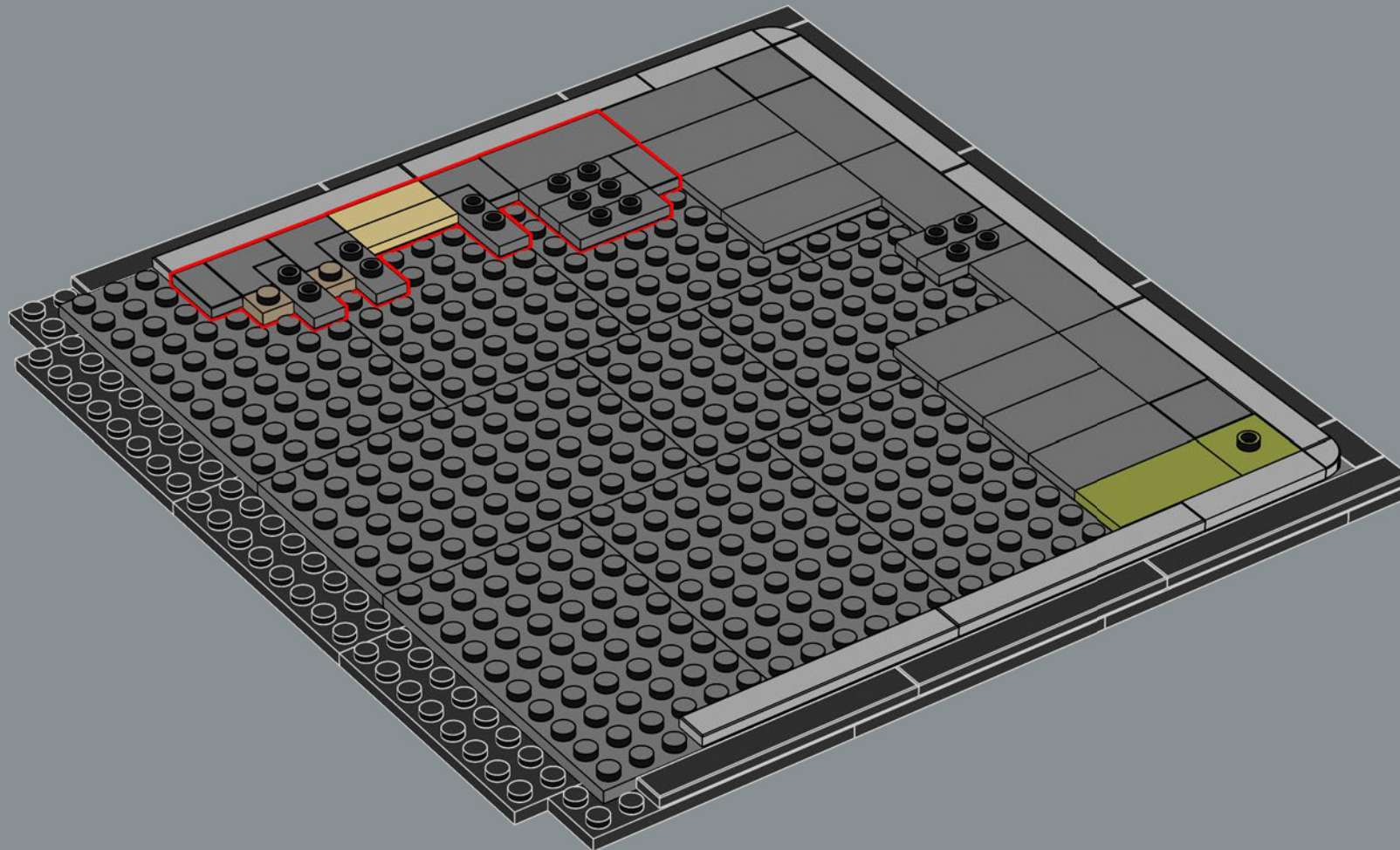

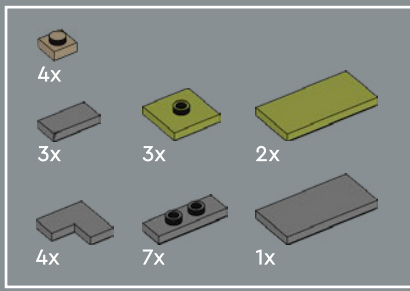

16

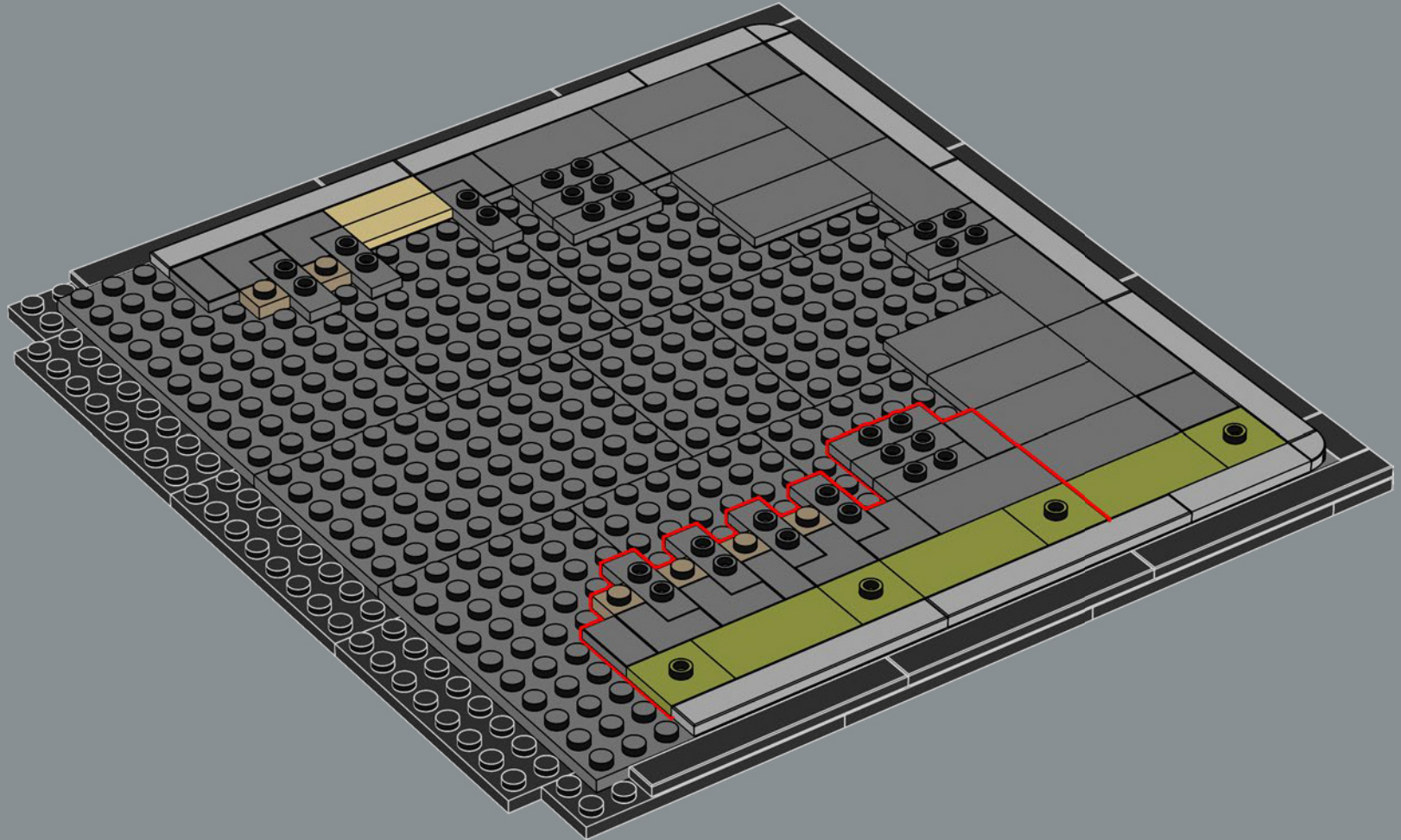

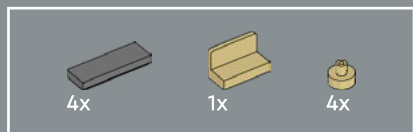

17

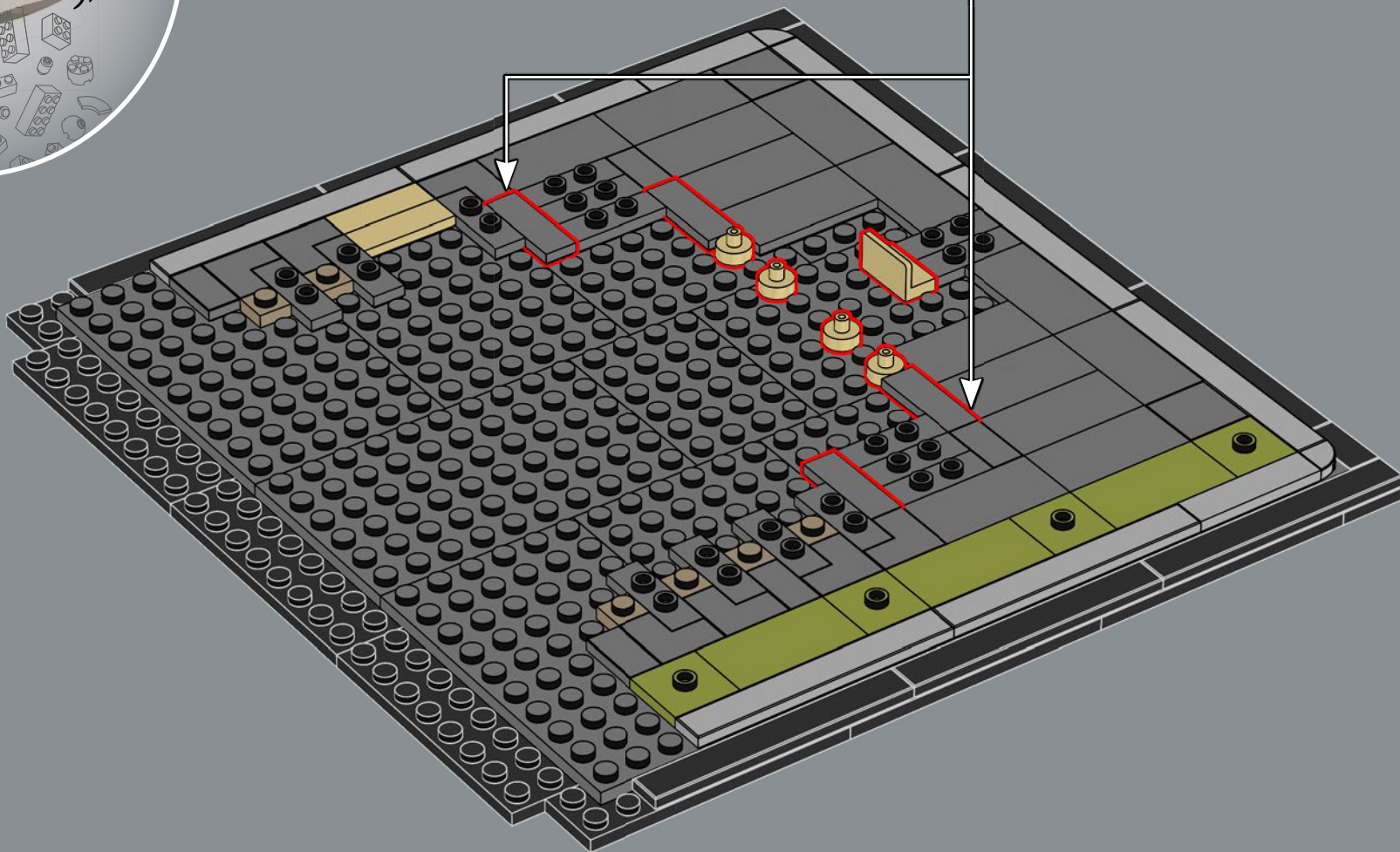
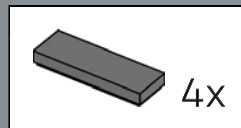



18

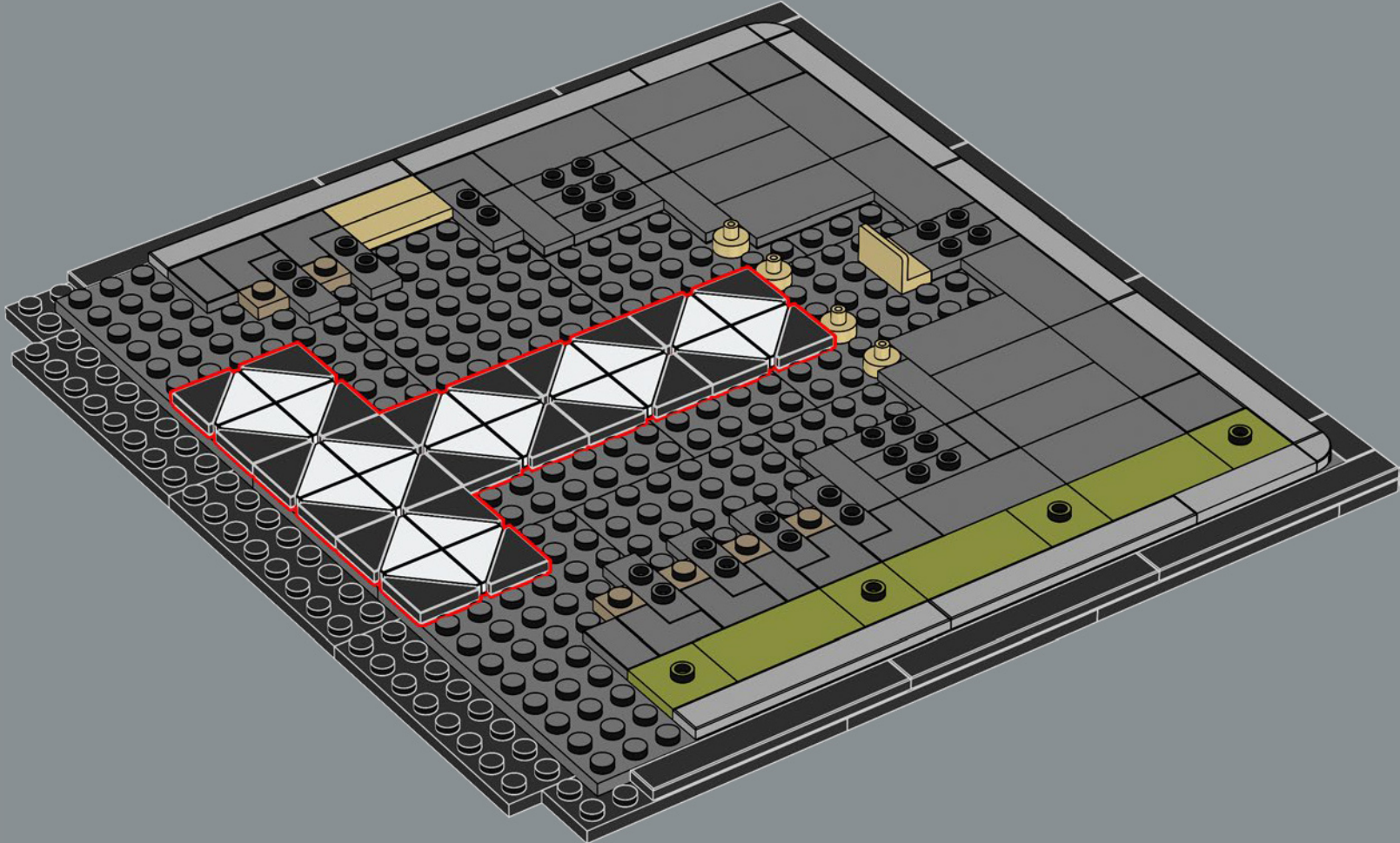



20x

19

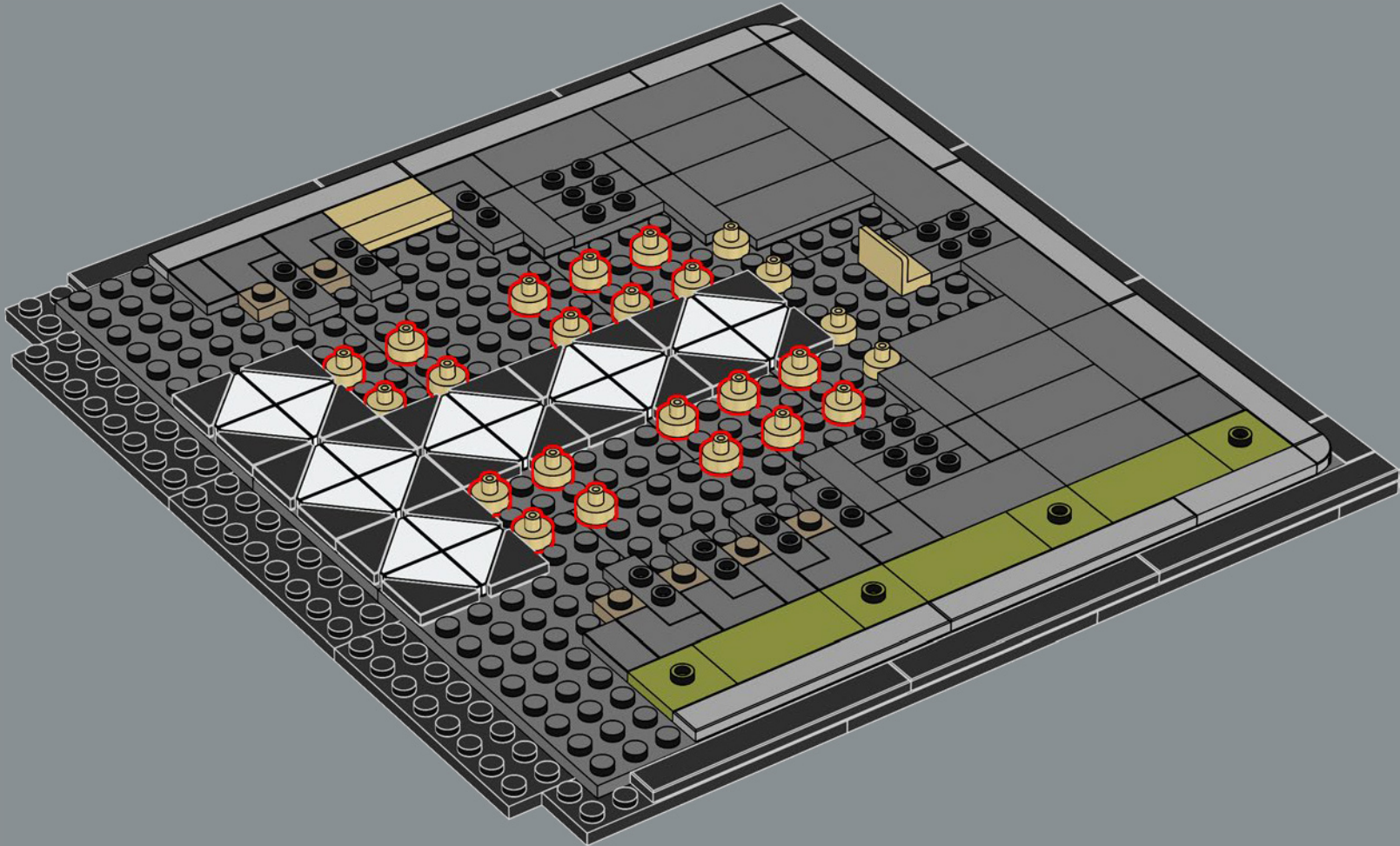

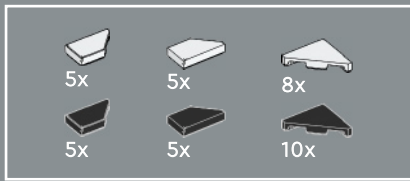

20

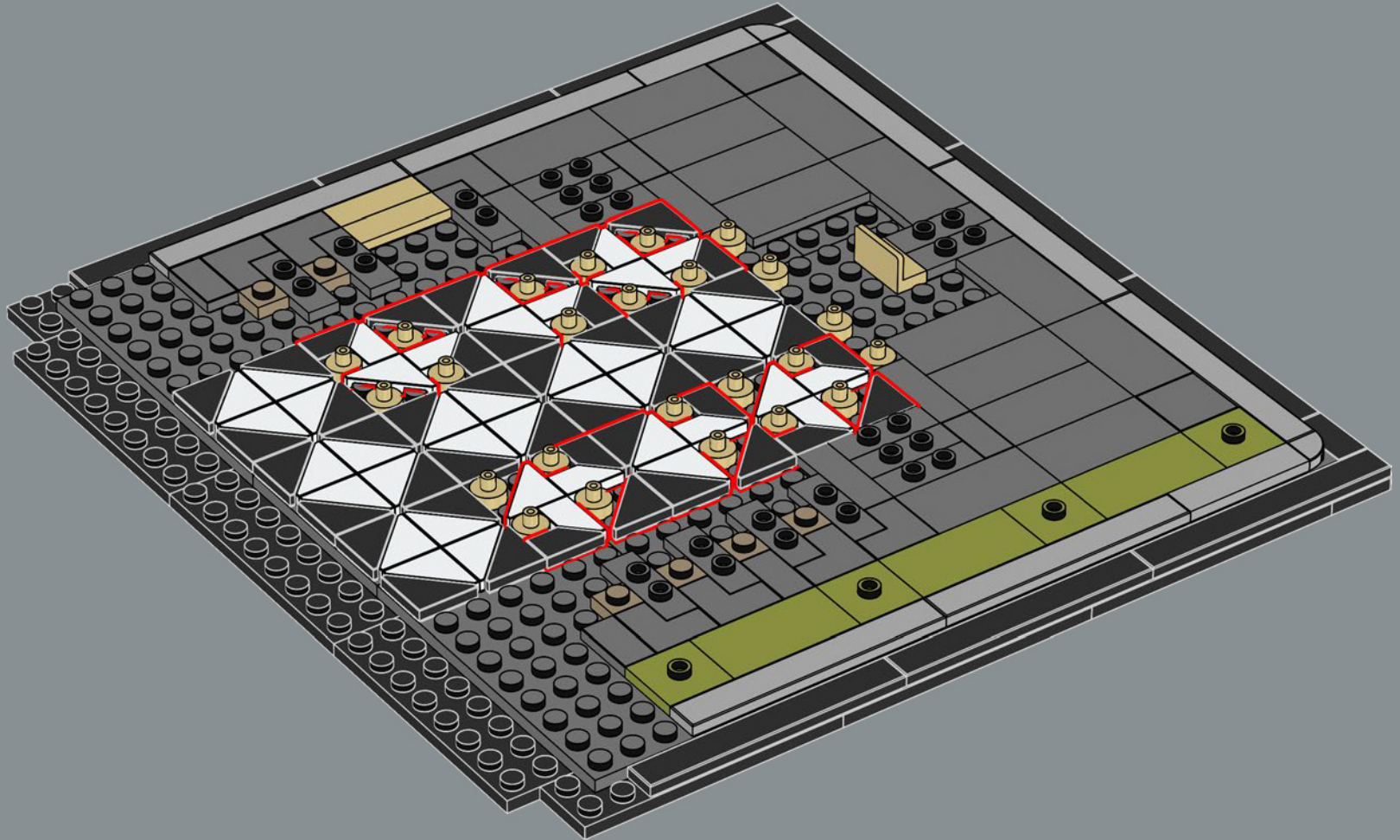

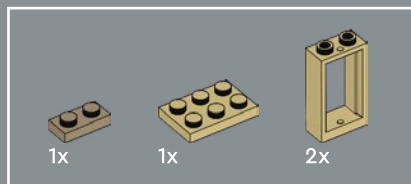

21

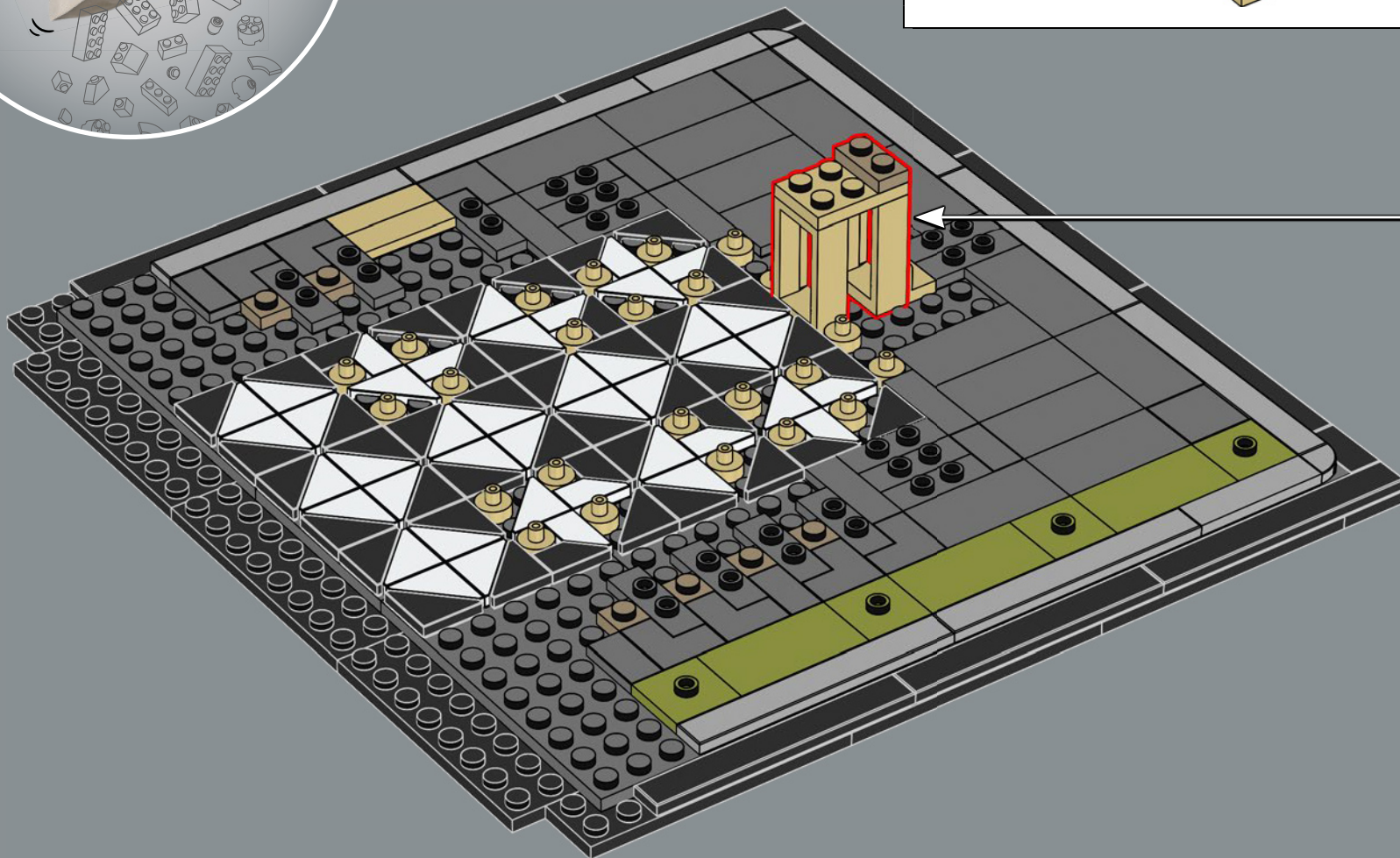
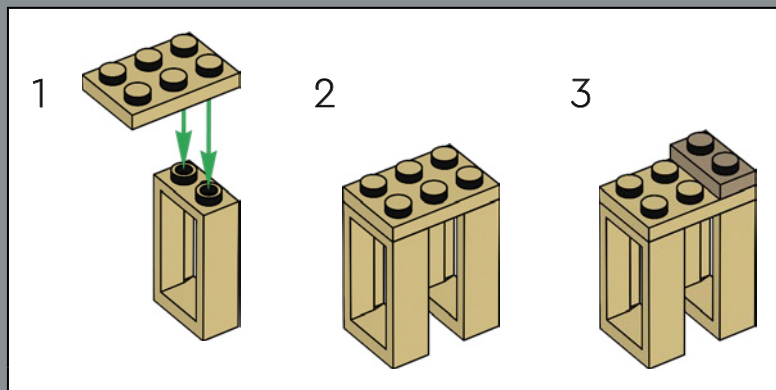



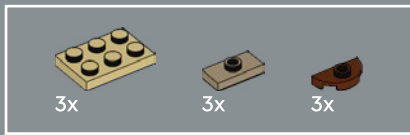

22

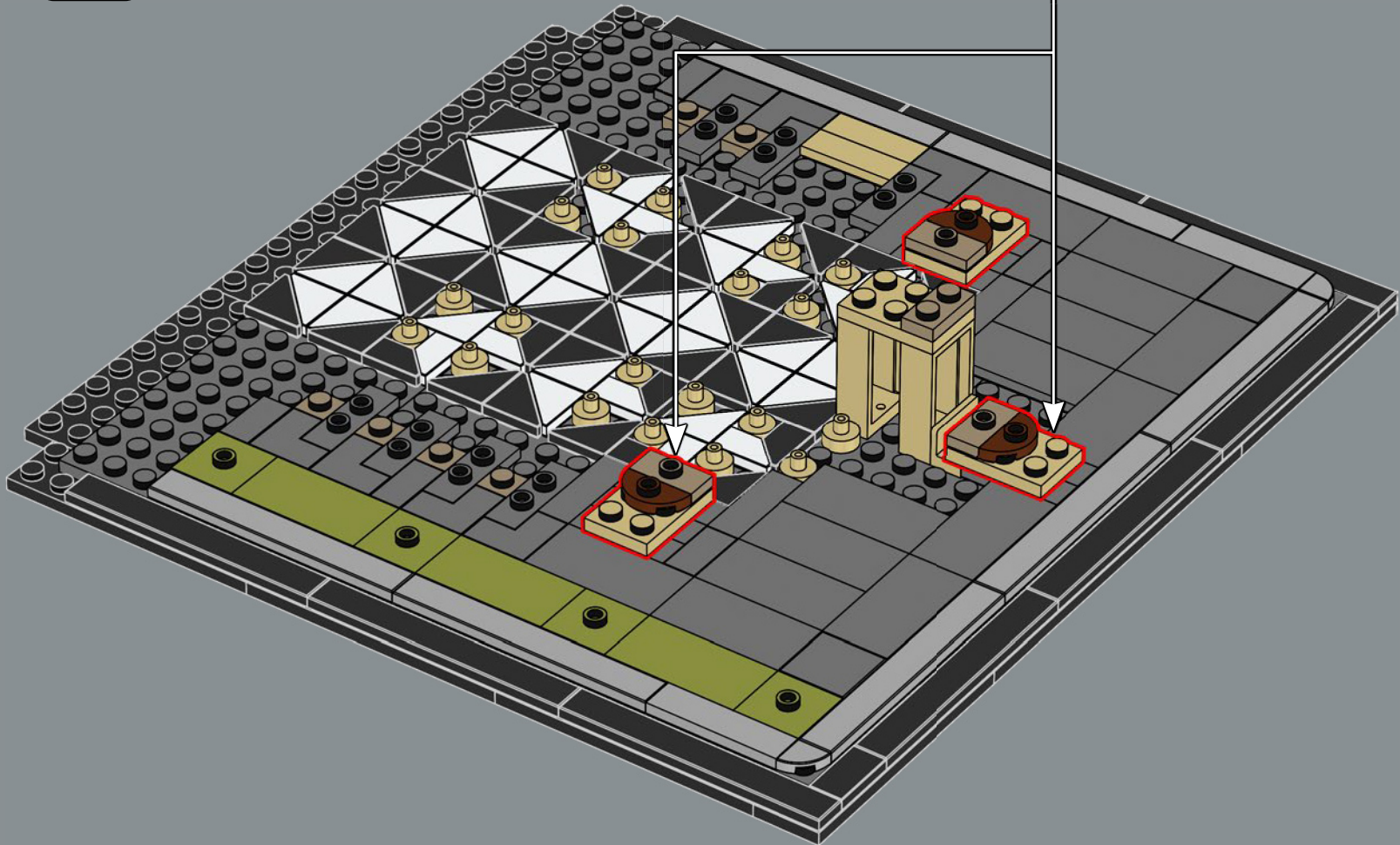
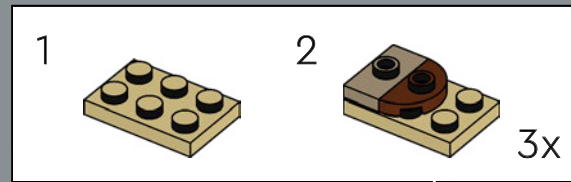

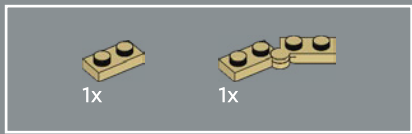

23

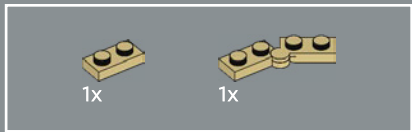
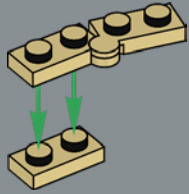

24

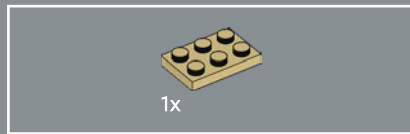
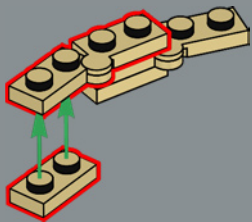

25

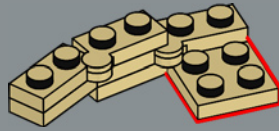

26

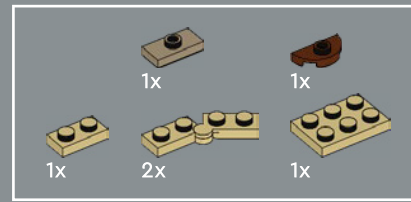
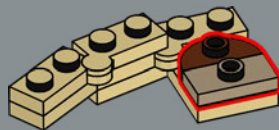

27

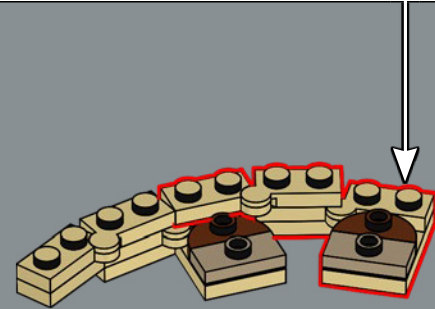
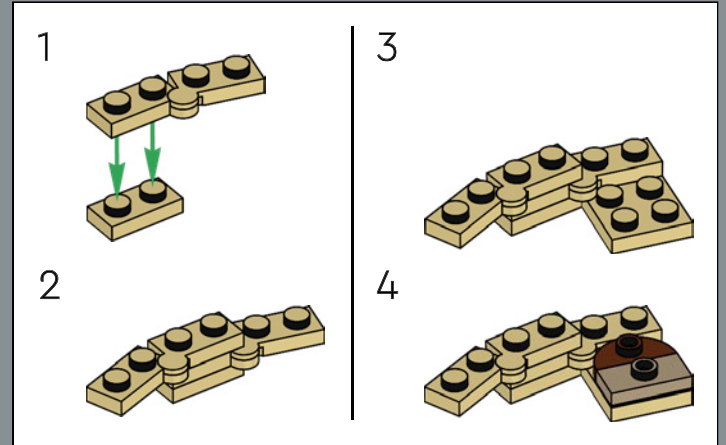

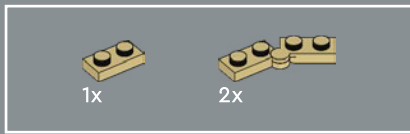

28

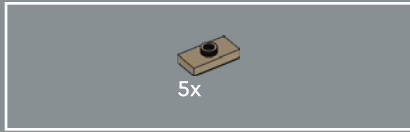
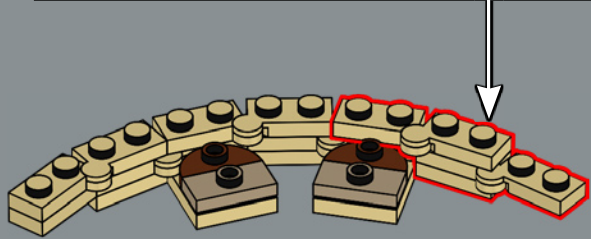
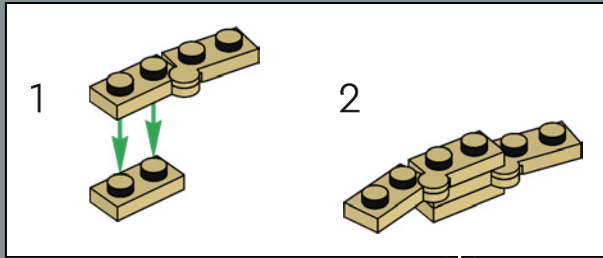

29

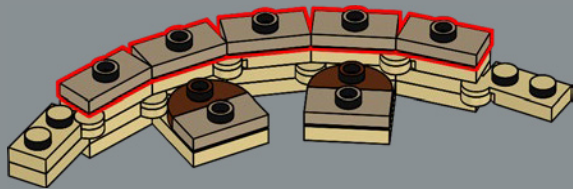

30

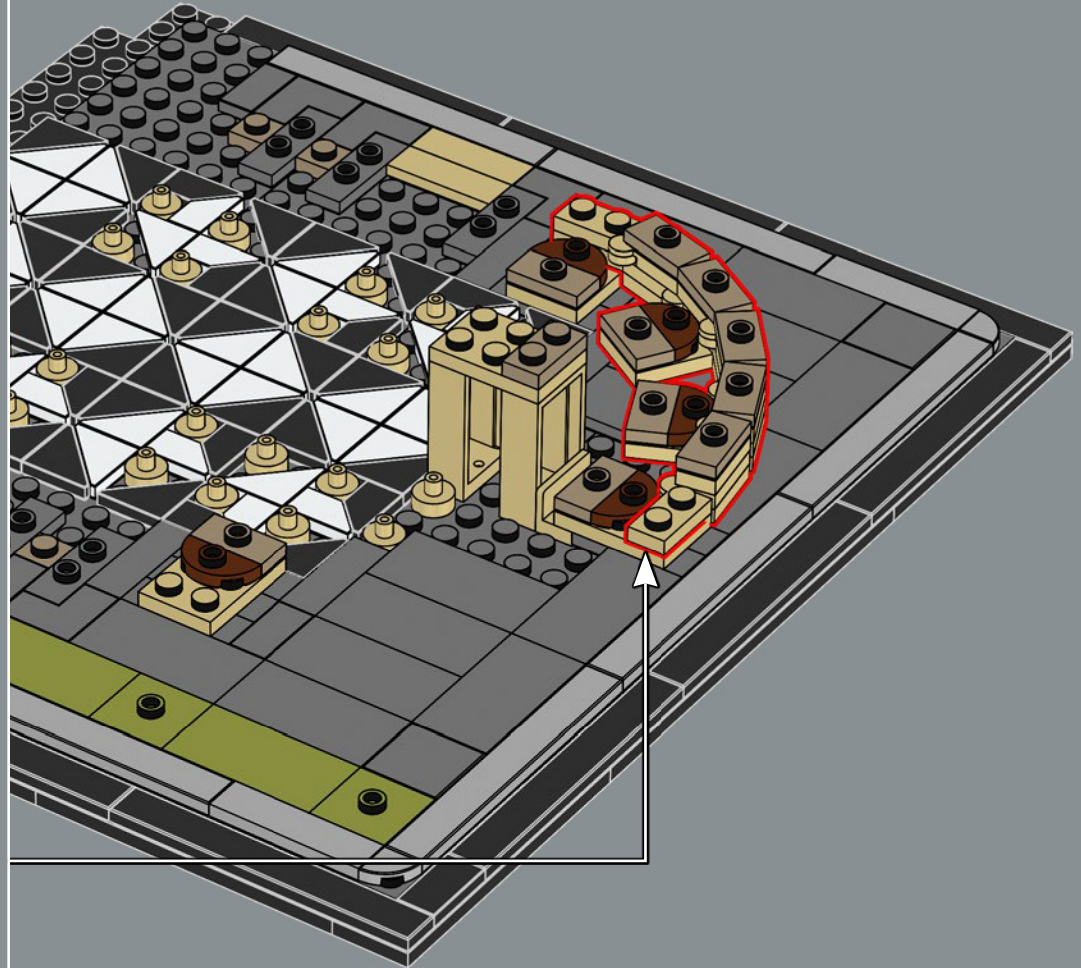

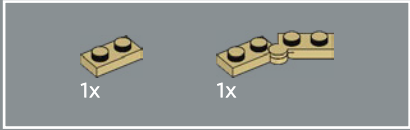
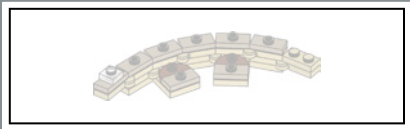

31

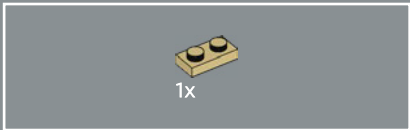
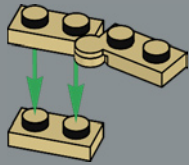

32

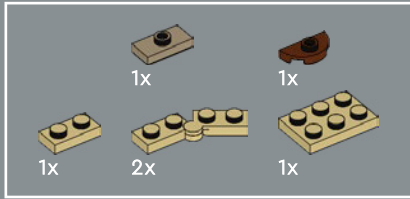

33

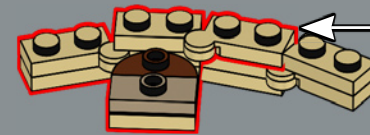
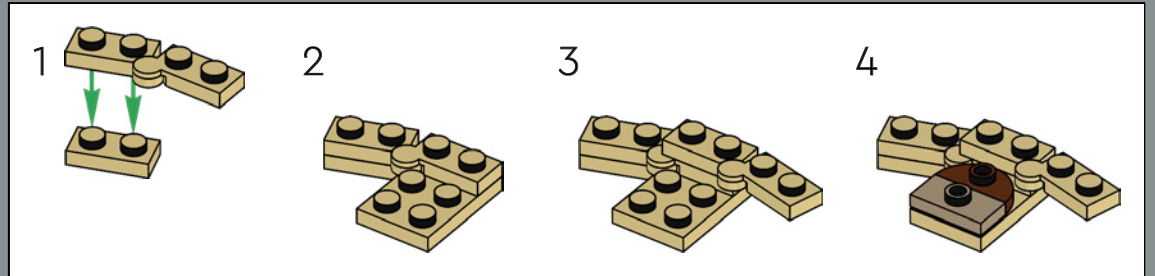



1163 - Gli elementi della pianta sono determinati attraverso una serie di cerchi realizzati con l'ausilio di funi di diversa lunghezza fissate a un palo al centro della cattedrale.

37

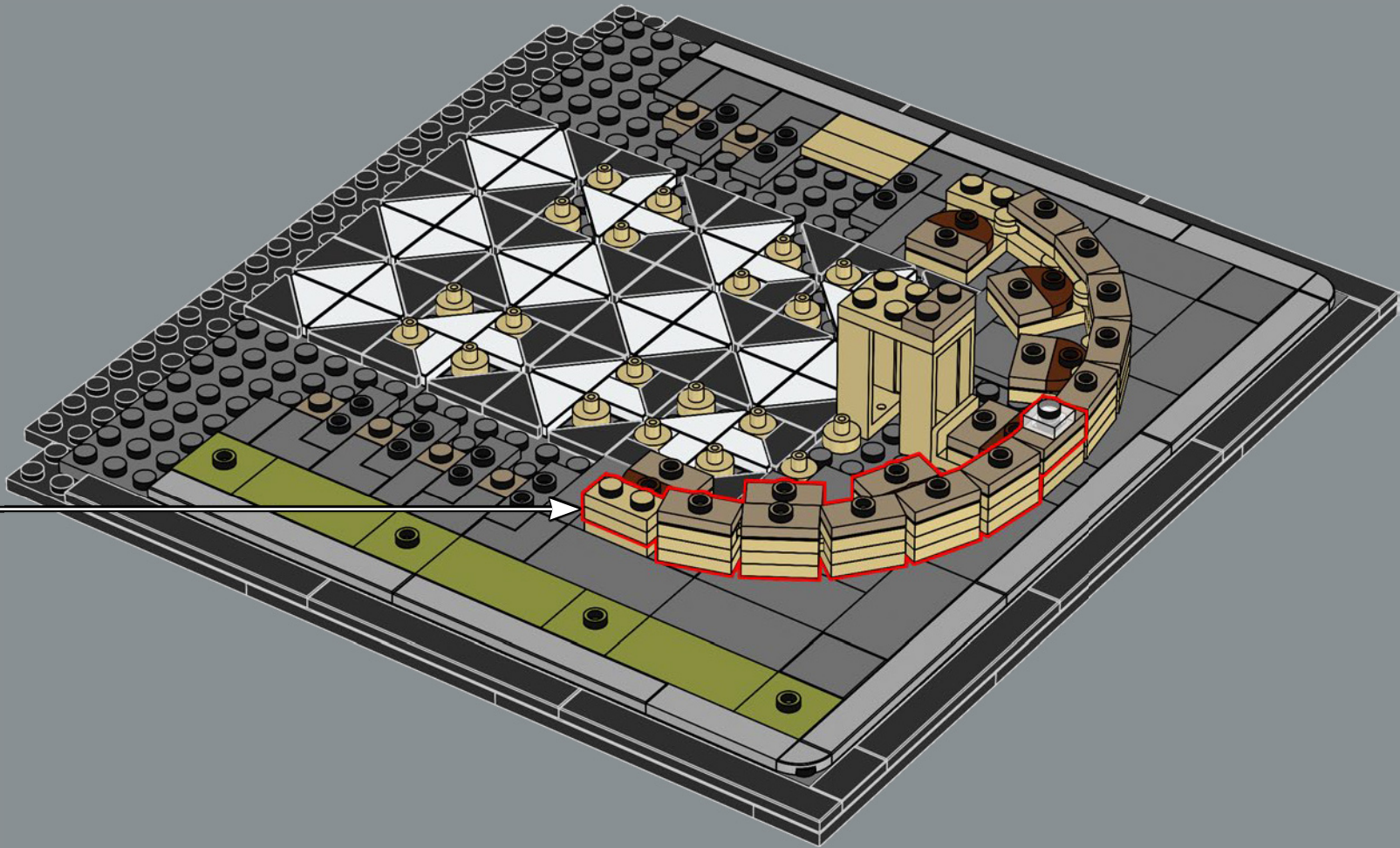

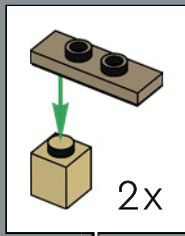
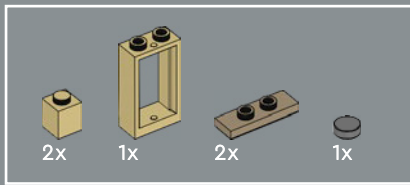

38

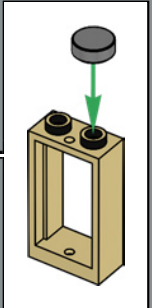
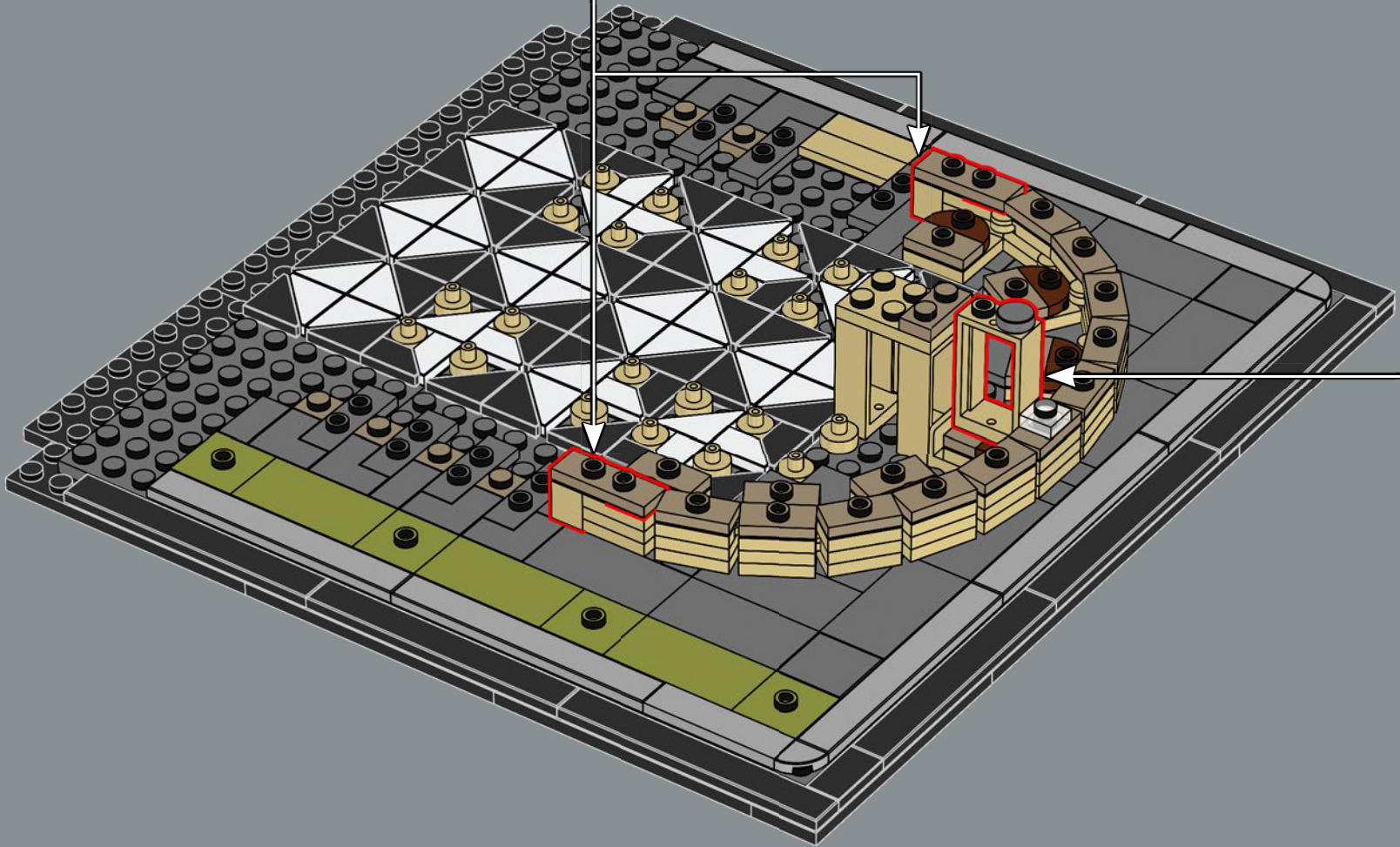

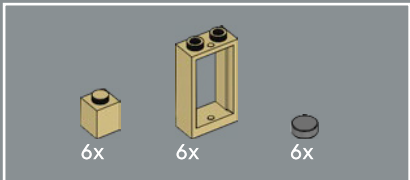

39

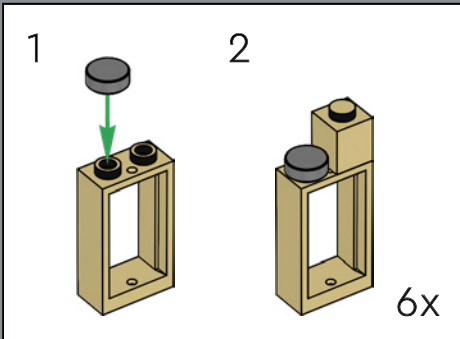

1163-1170 - Viene costruita l'abside, con i contrafforti organizzati secondo una disposizione eccentrica.

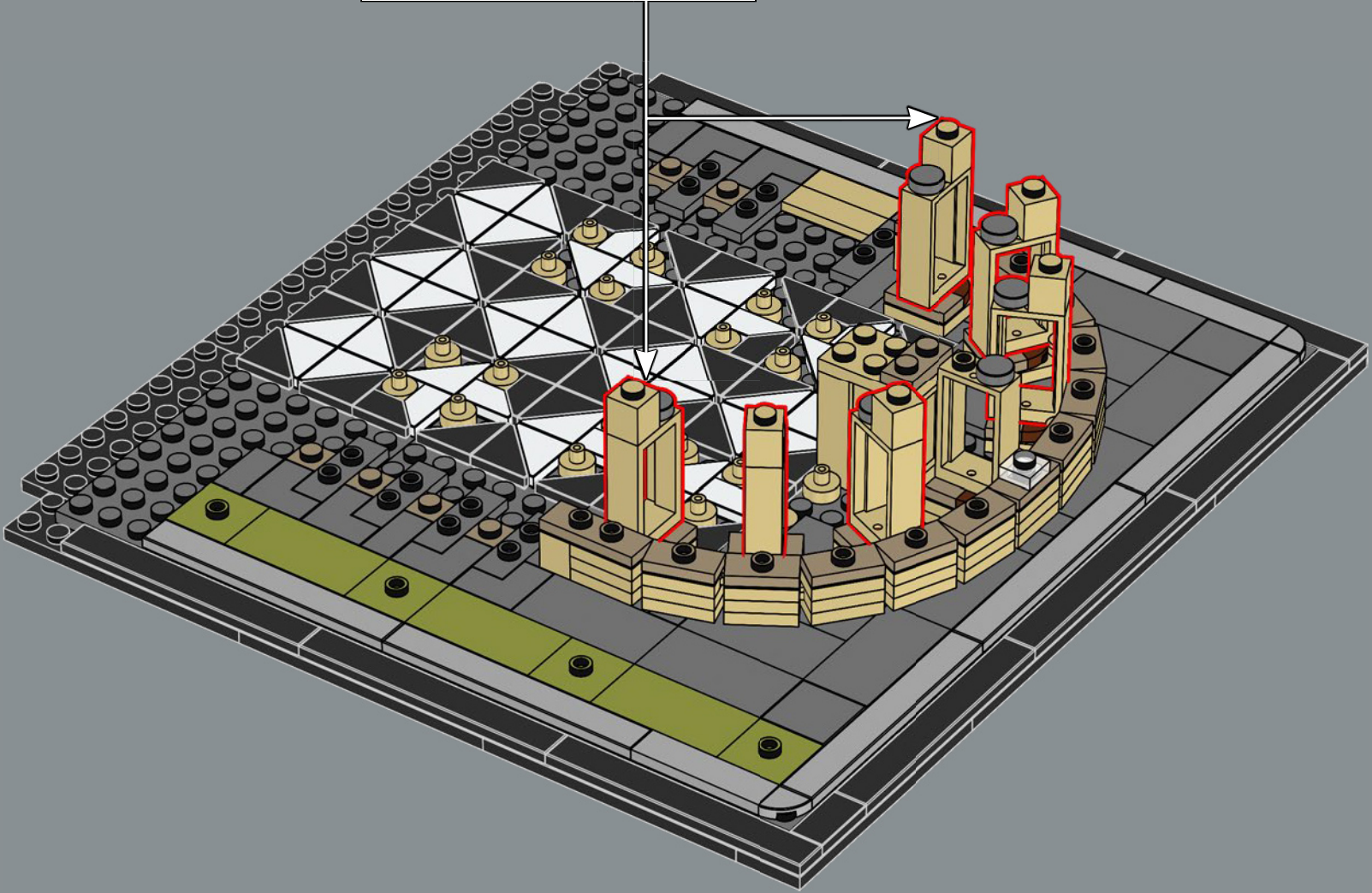





40

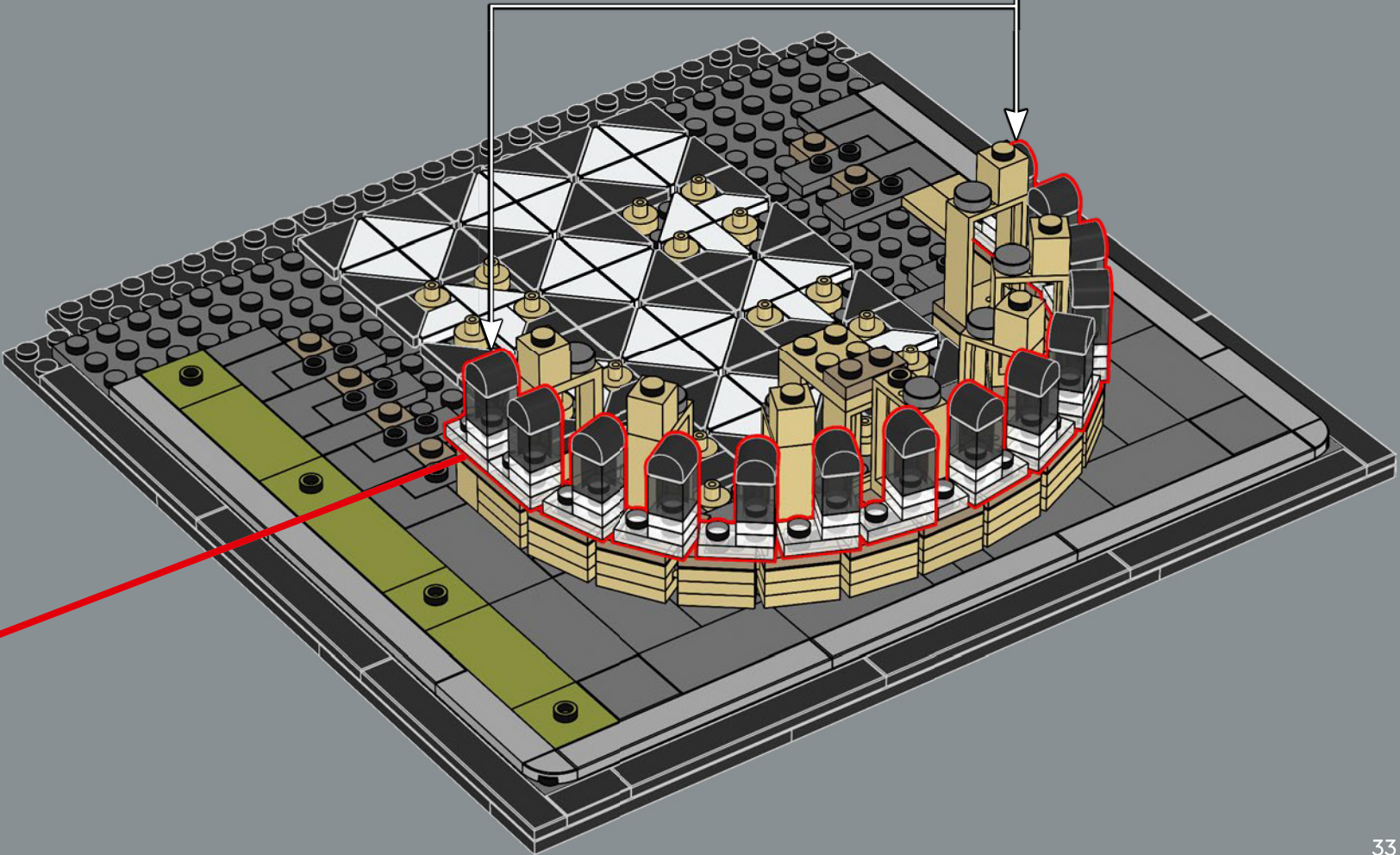
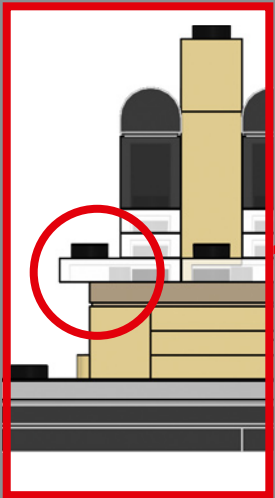
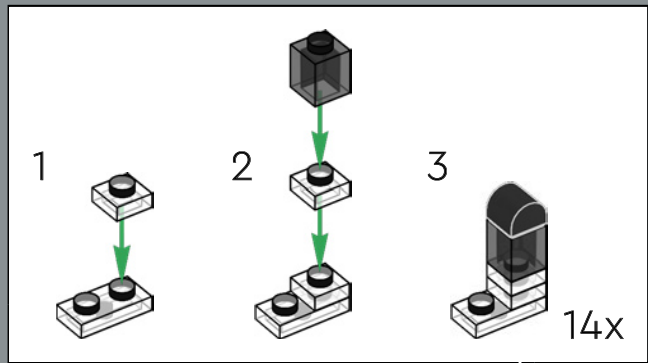

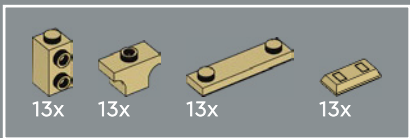

41

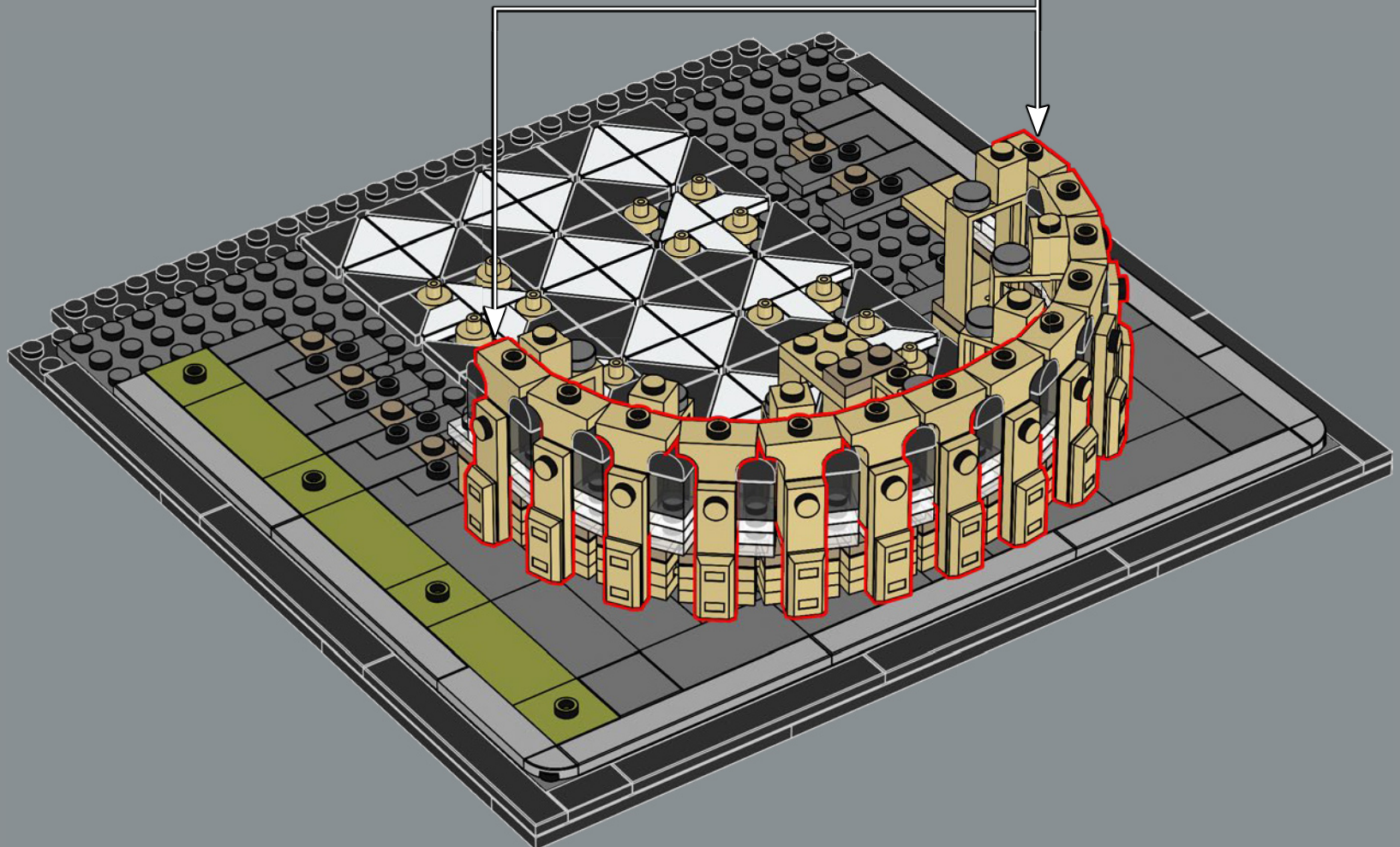
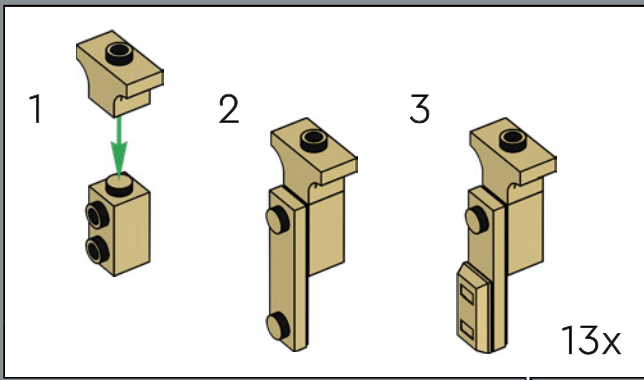

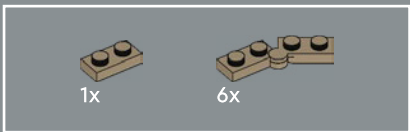

42

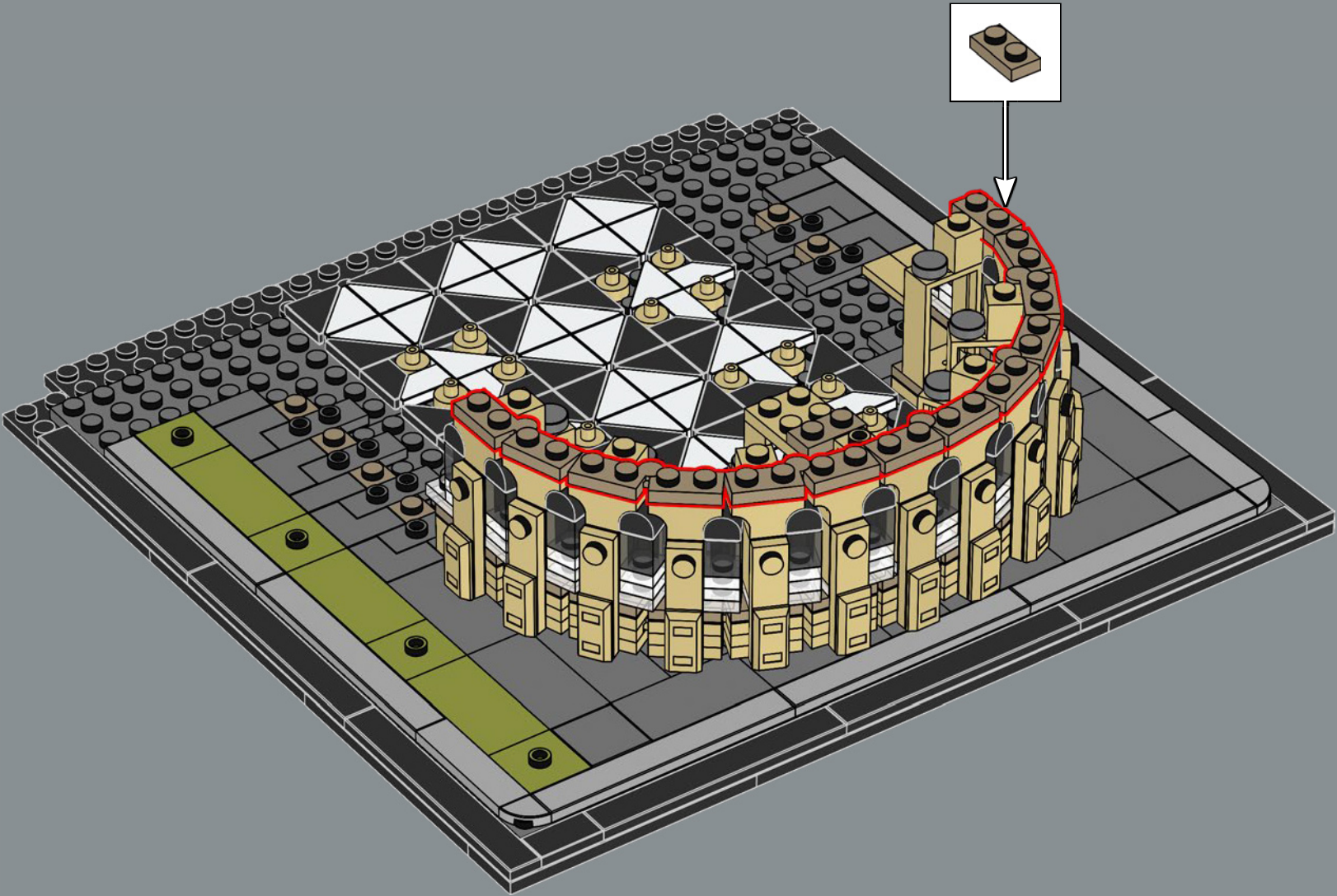

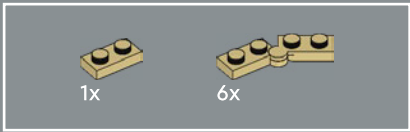

43

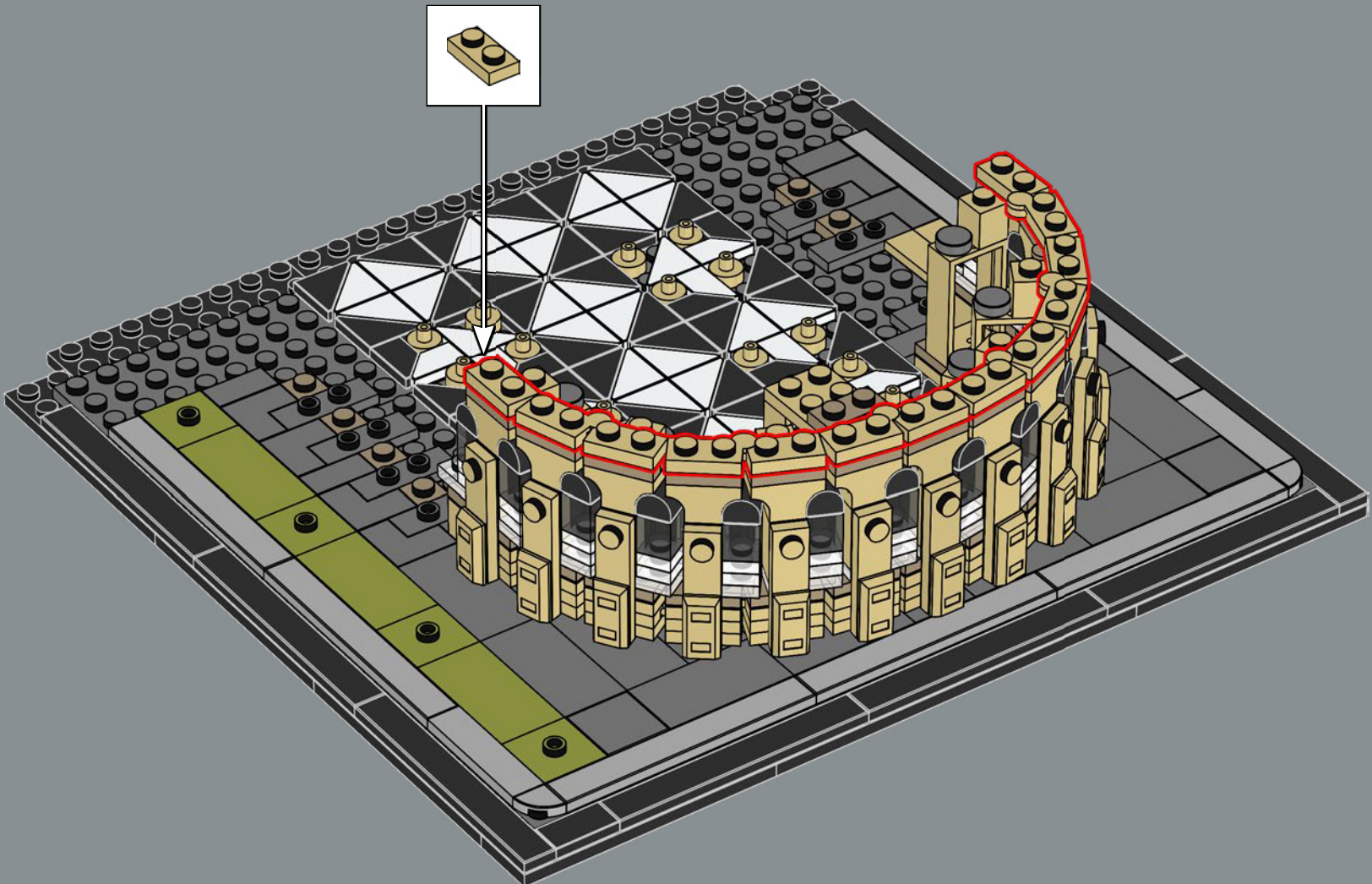

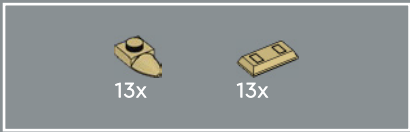

44

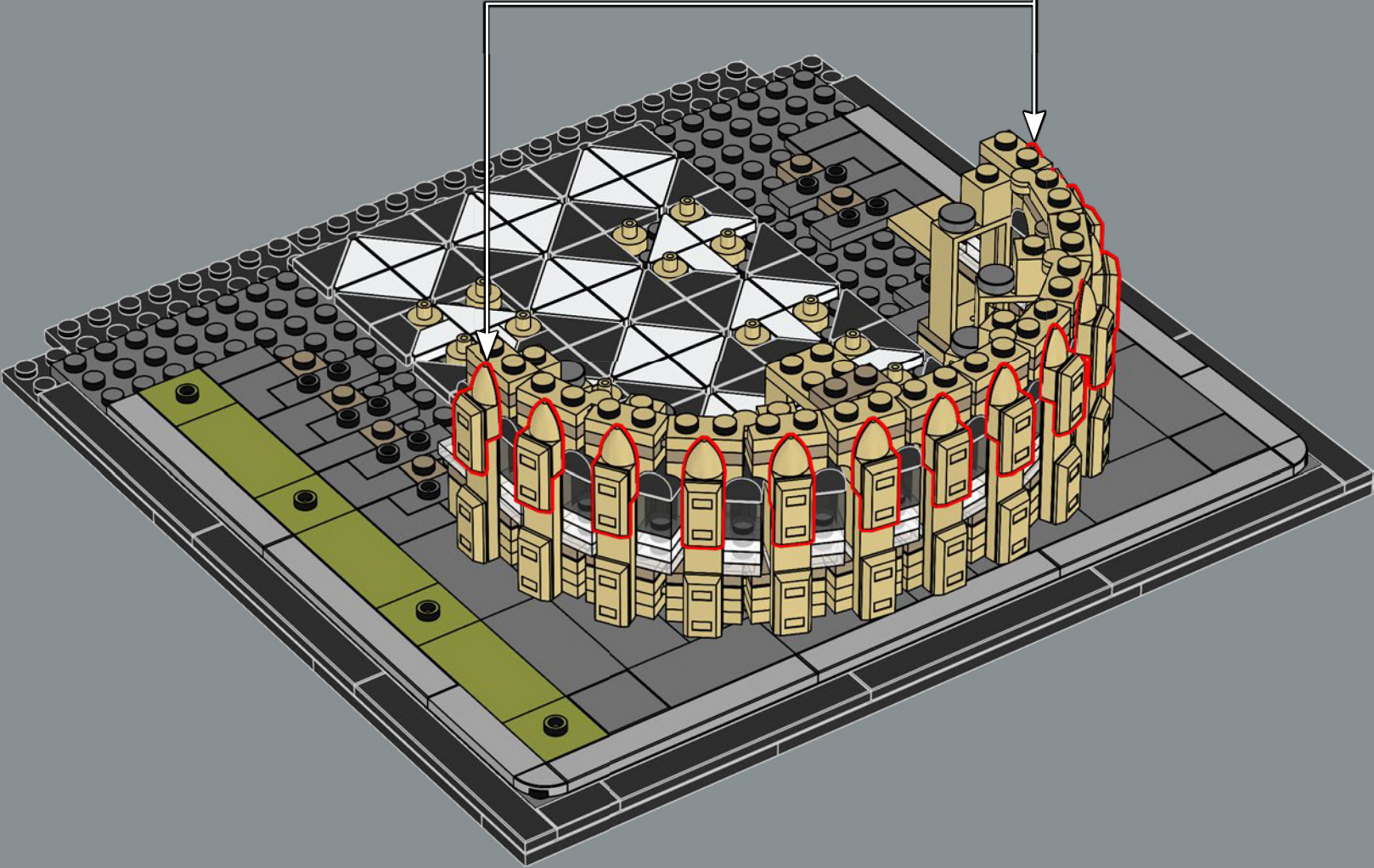
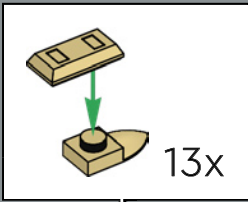

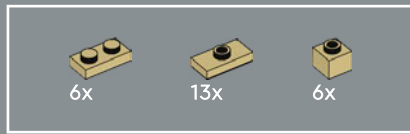

45

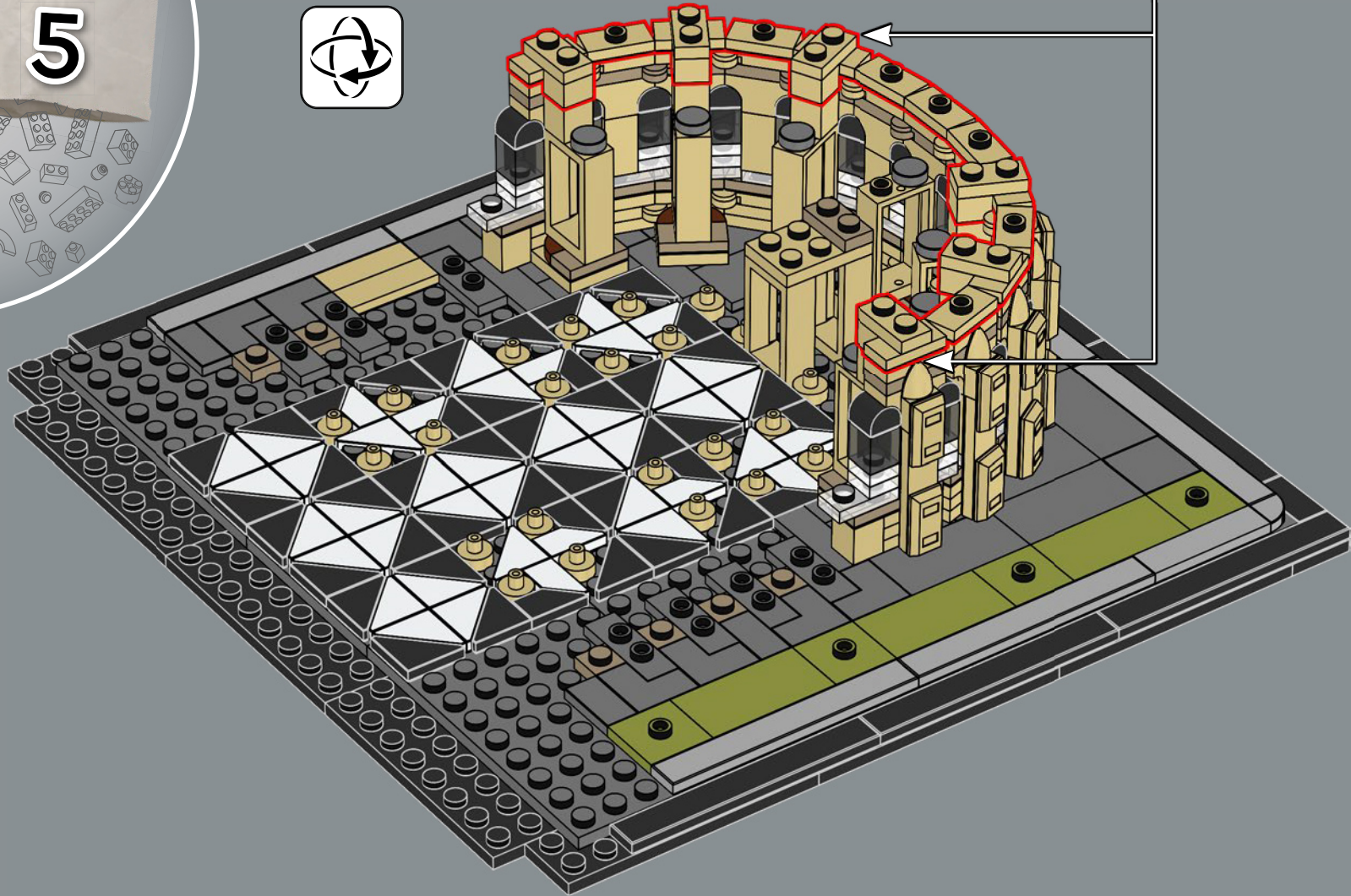
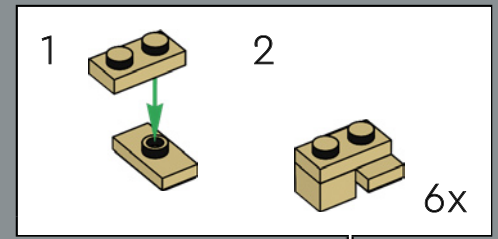



46

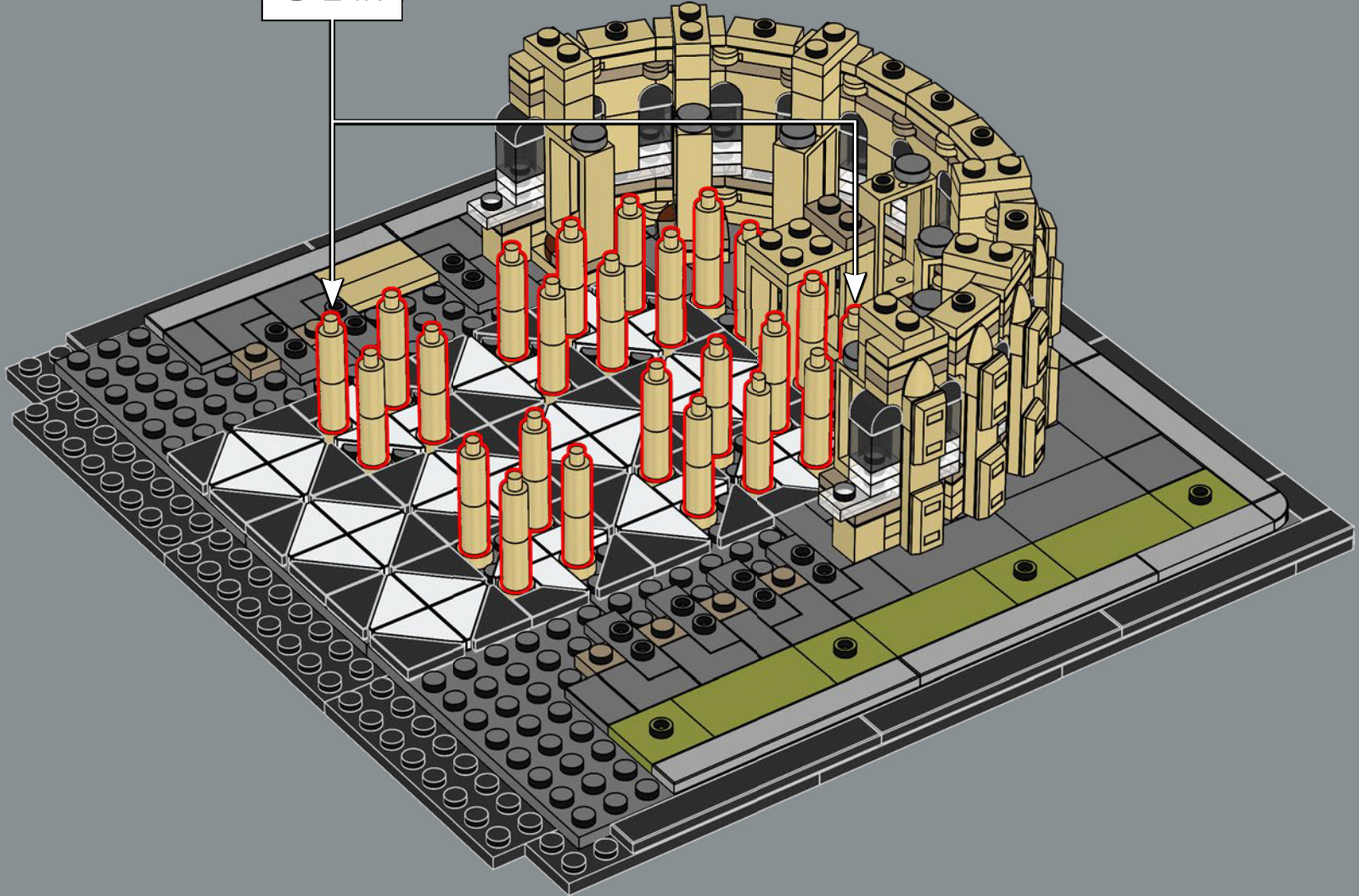
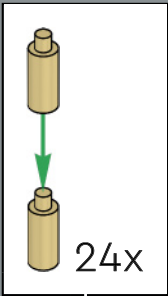

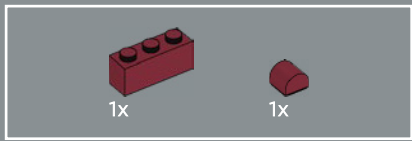

47

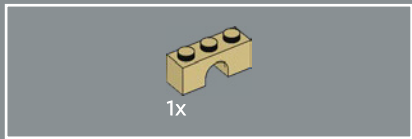
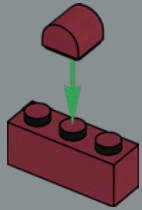

48

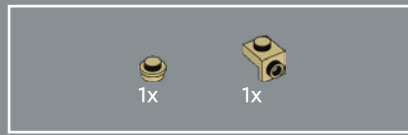
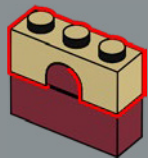

49

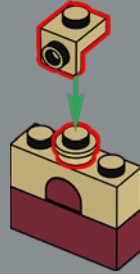

50

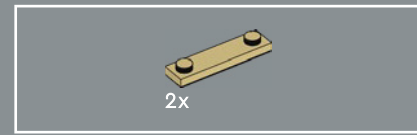
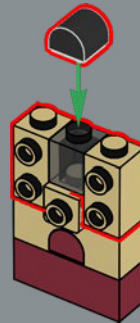

51

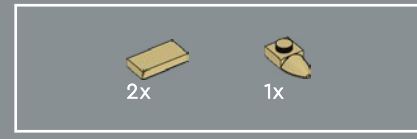
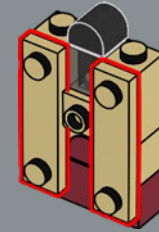

52

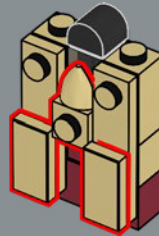



Un elegante portale che offre accesso diretto al coro prende il nome dal colore dei battenti del portale: la Porte Rouge (porta rossa). La porta fu ristrutturata intorno al 1270.

53

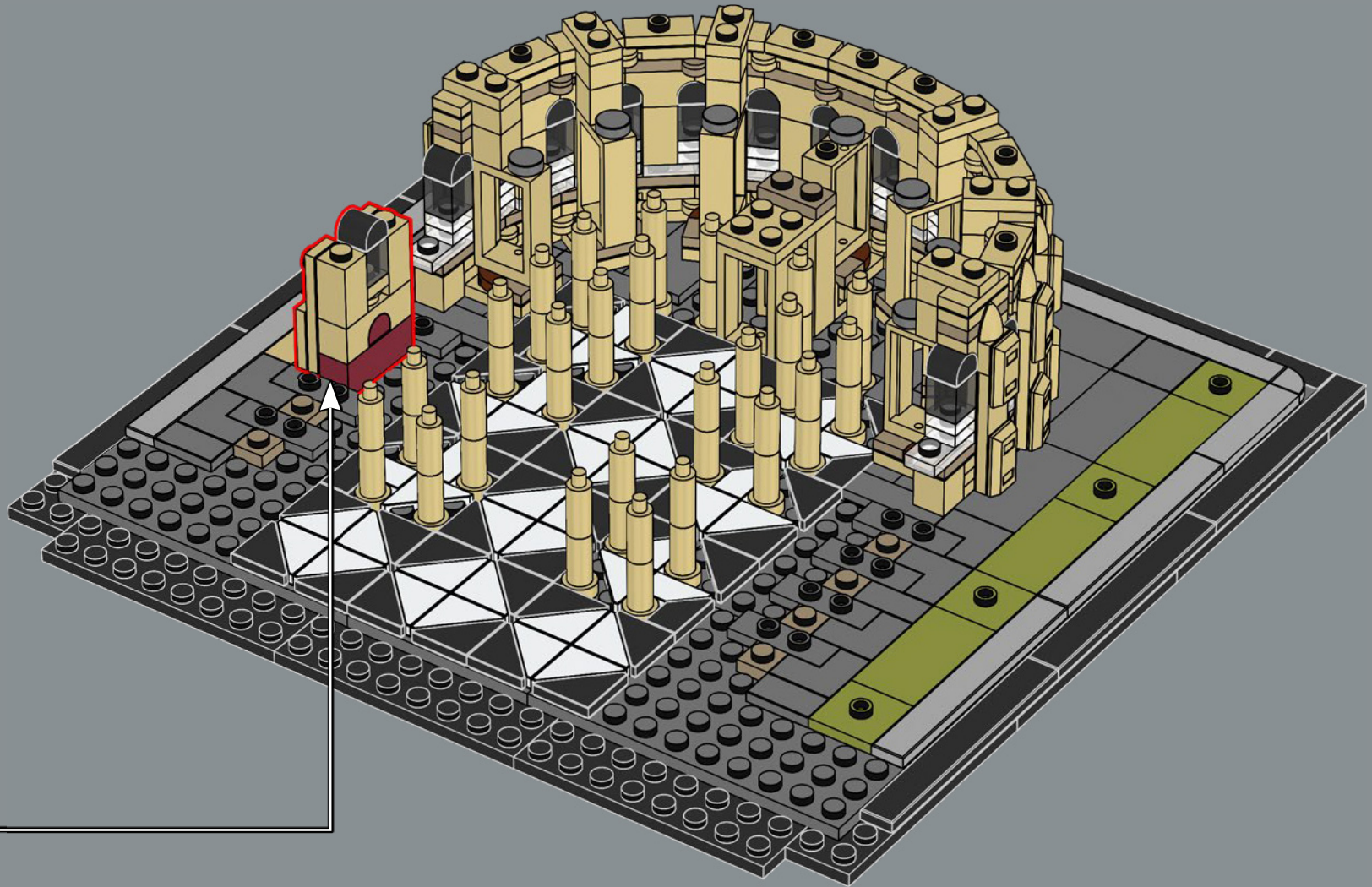

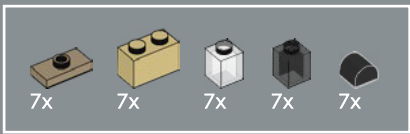

54

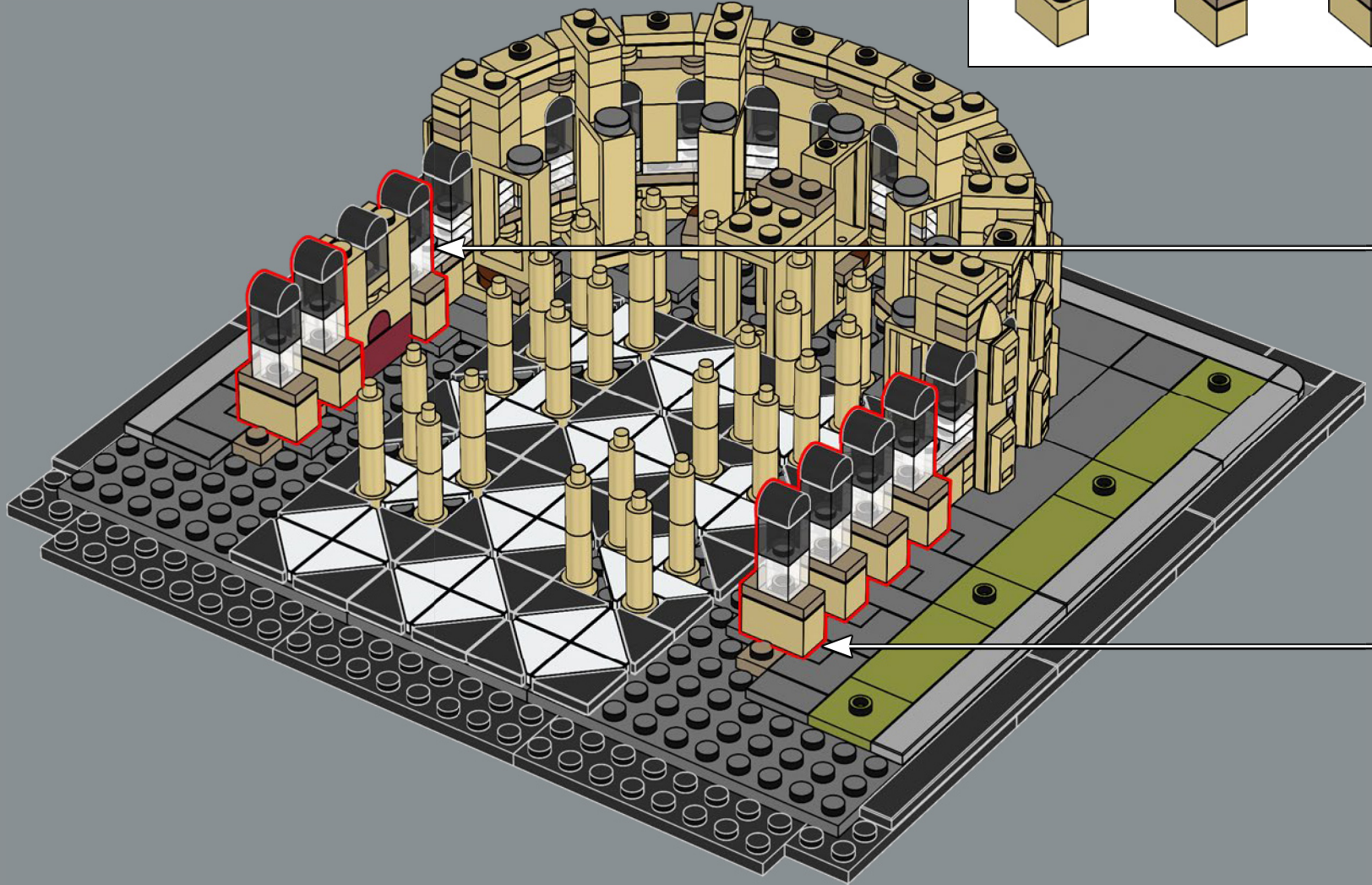
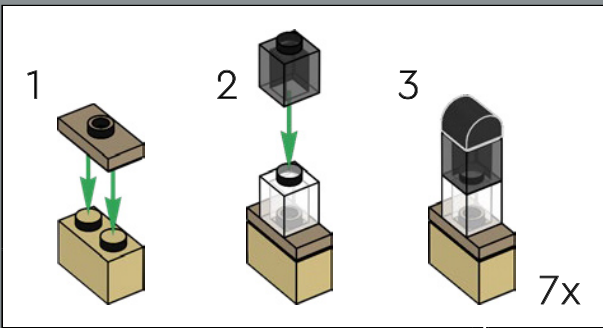

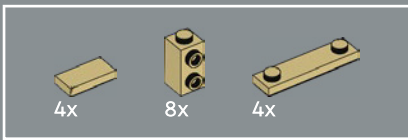

55

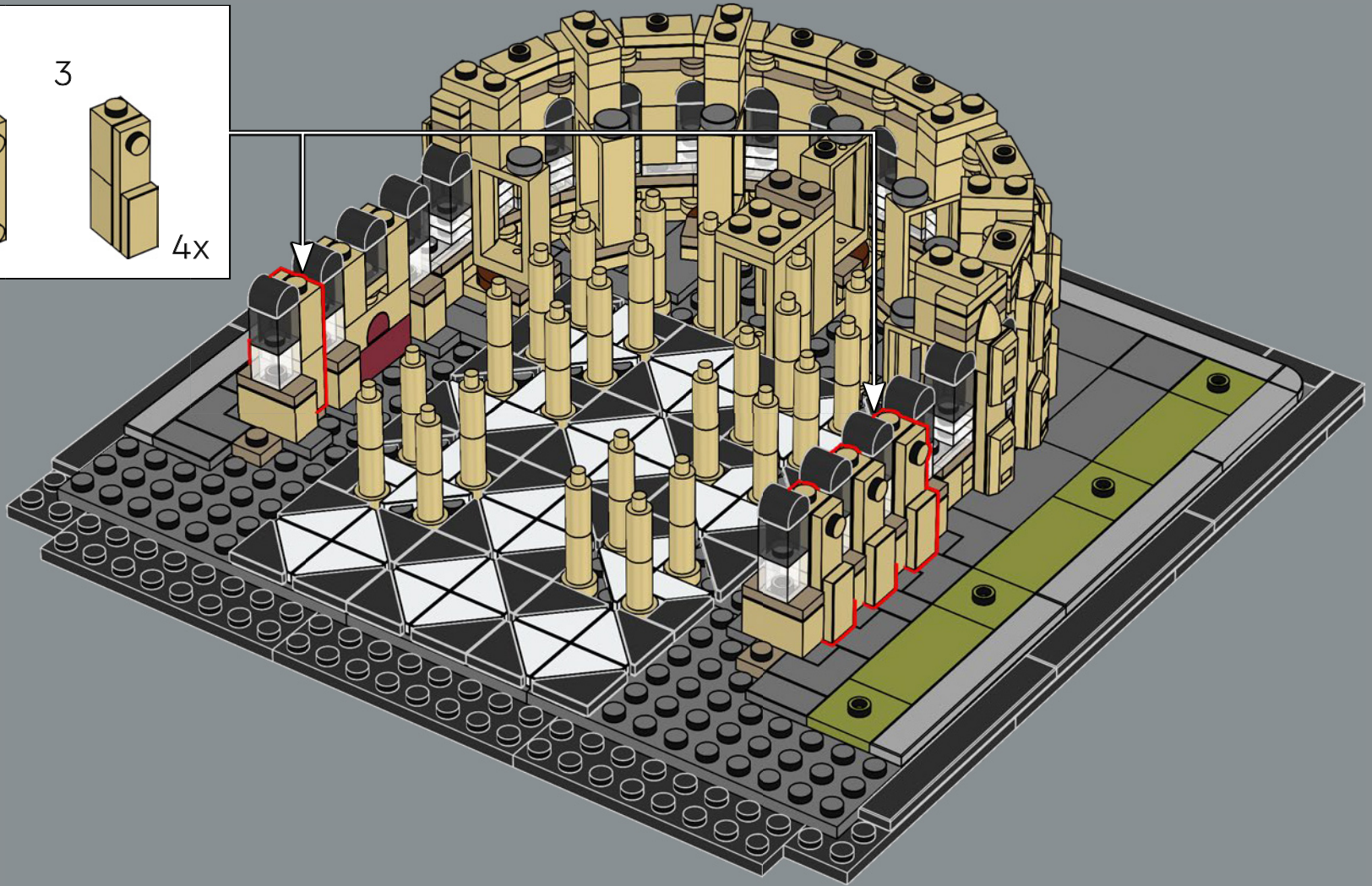
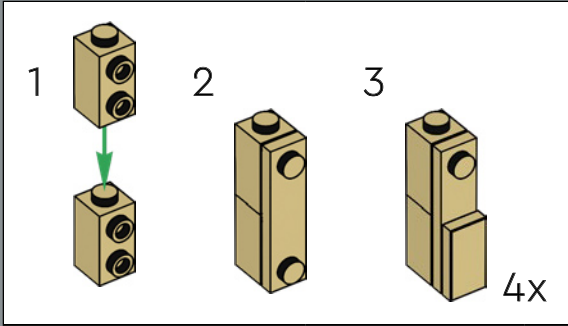

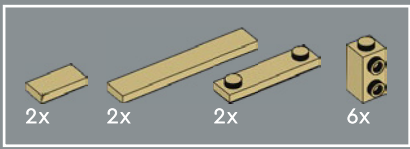

56

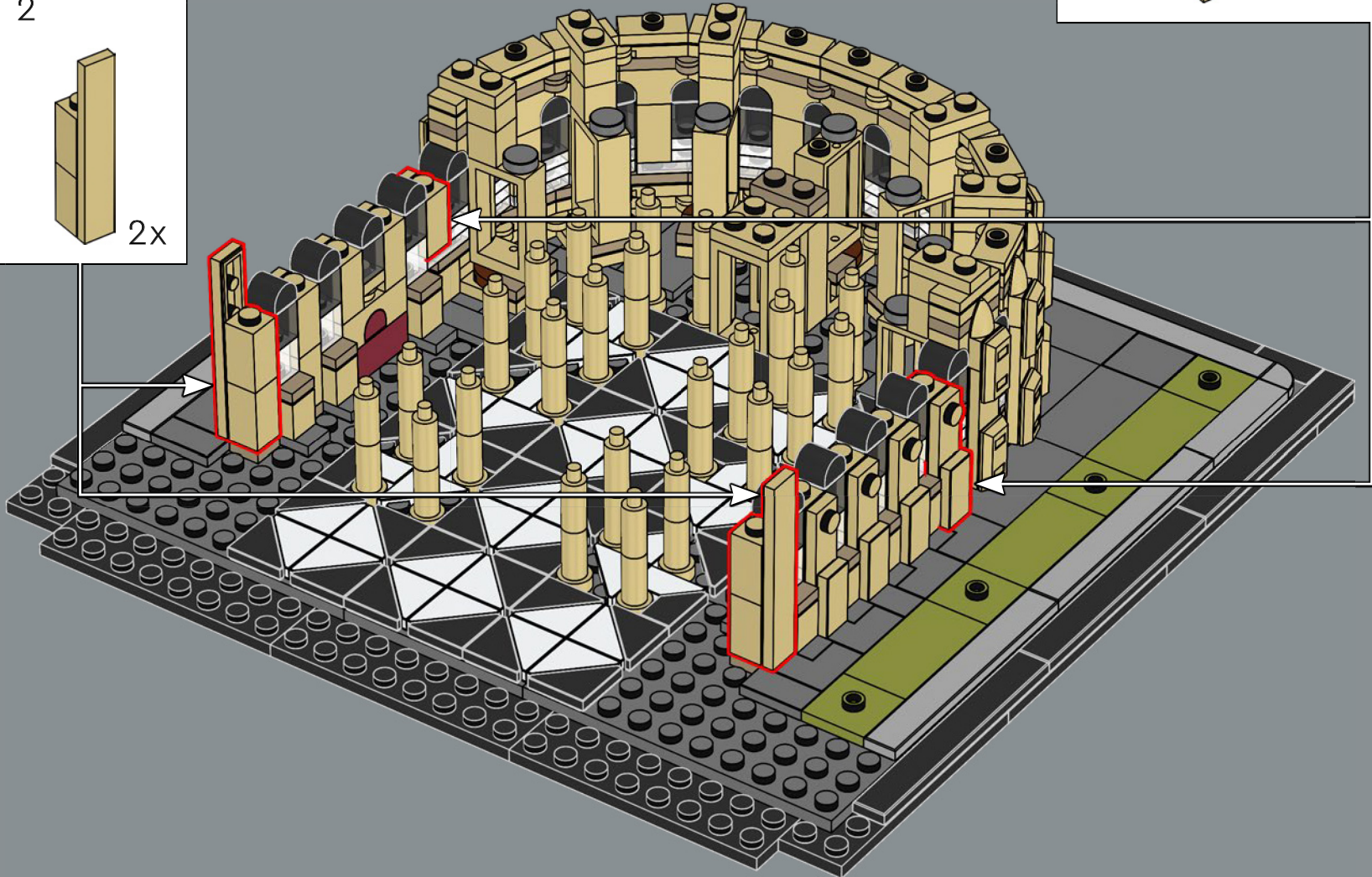
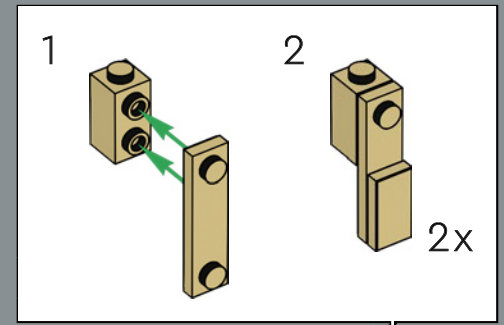
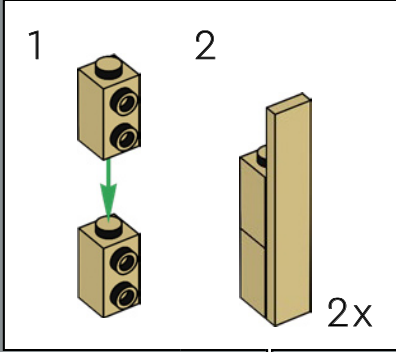

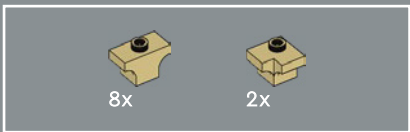

57

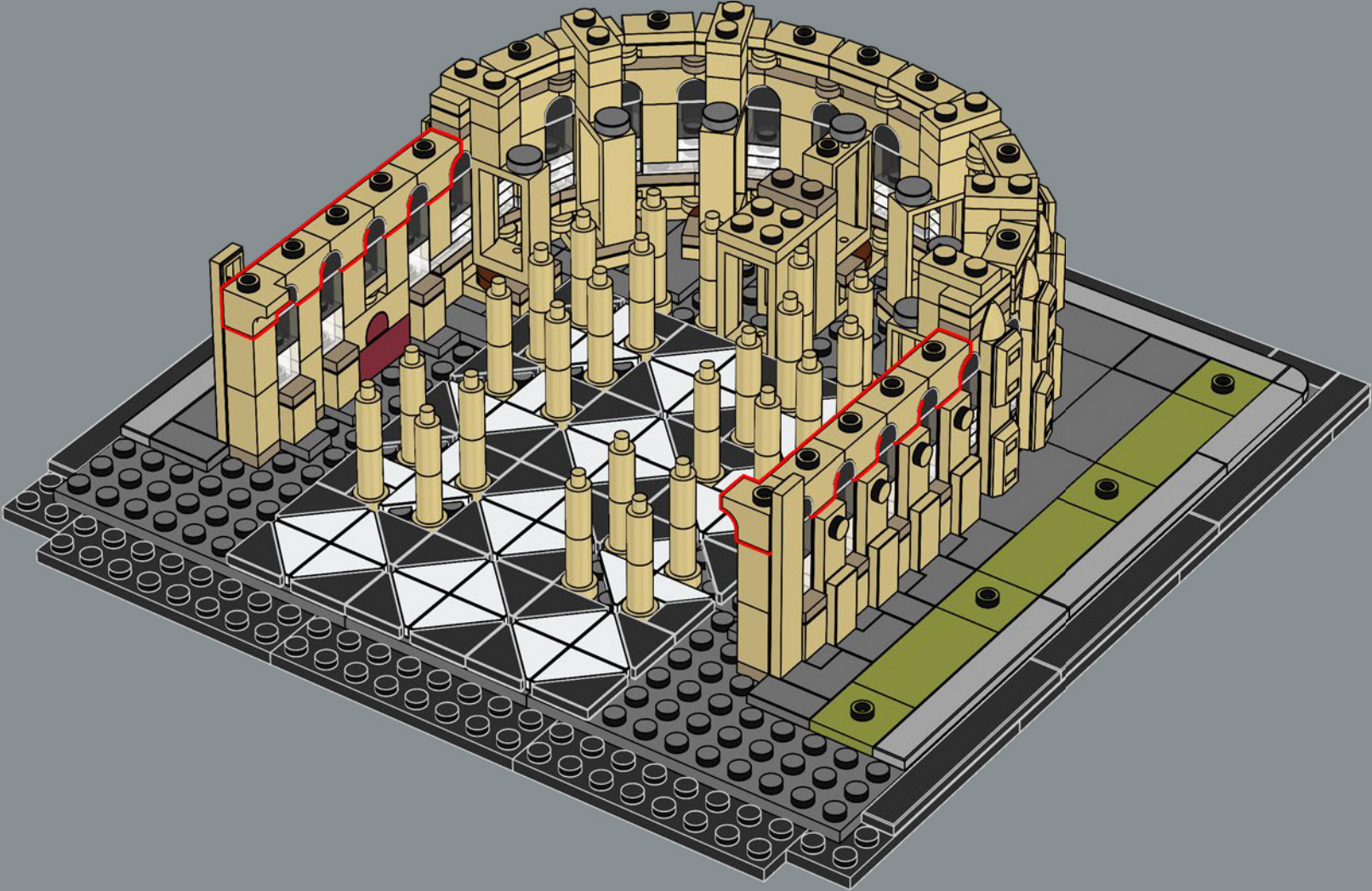

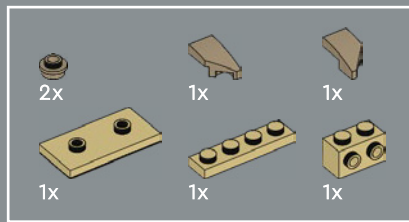

58

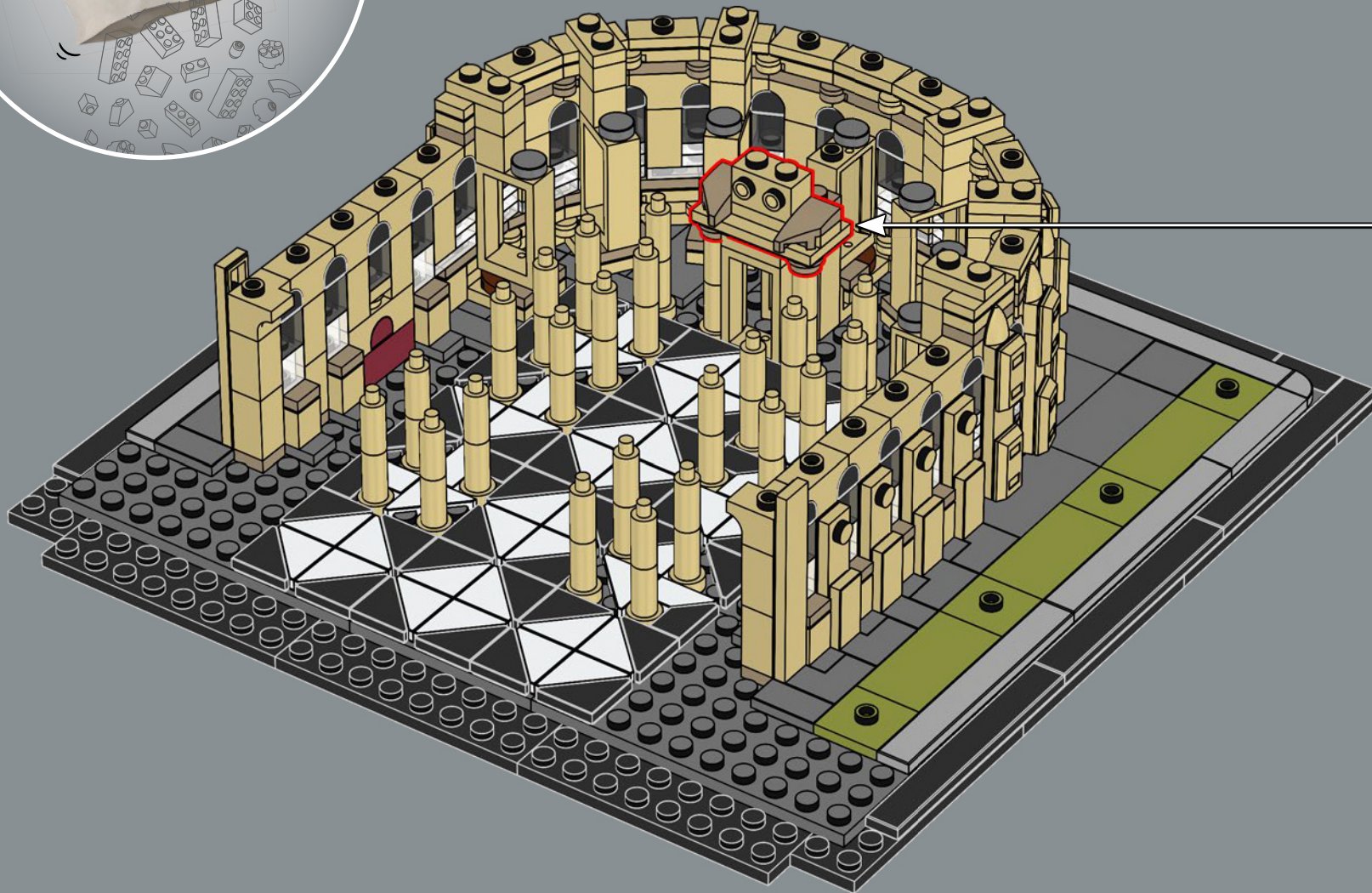
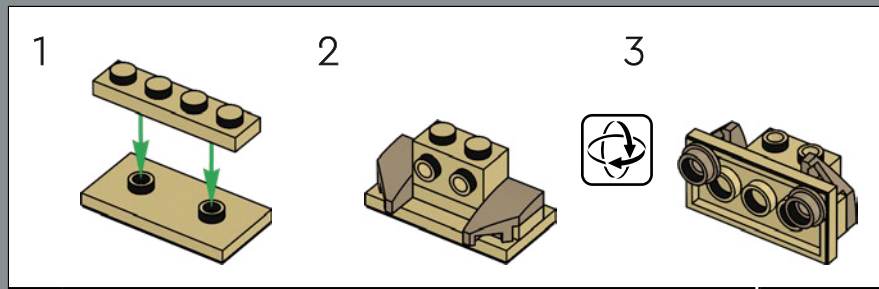

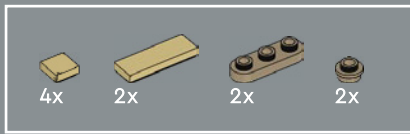

59

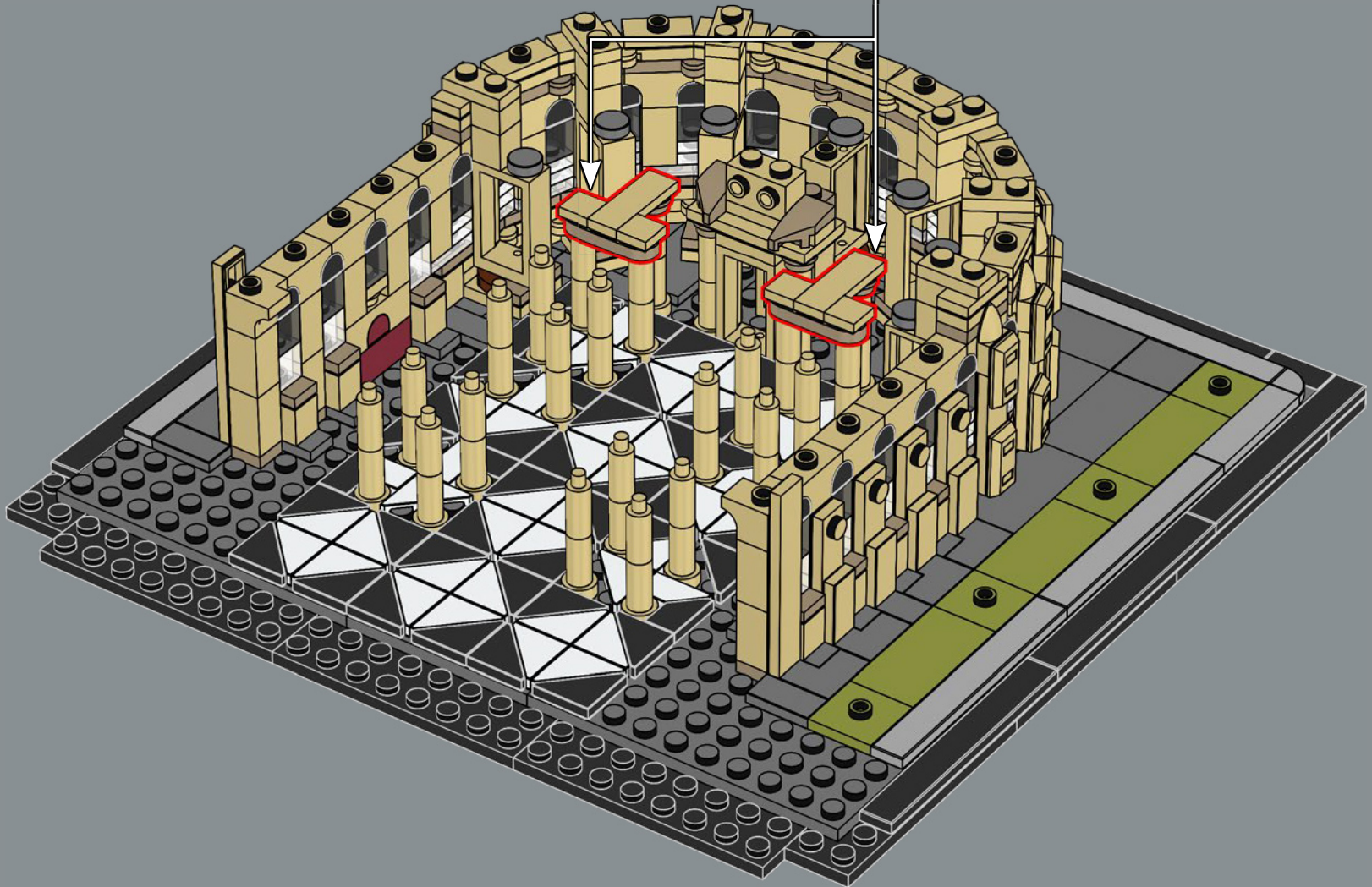
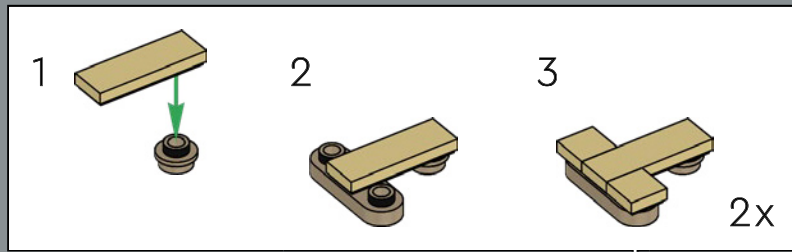

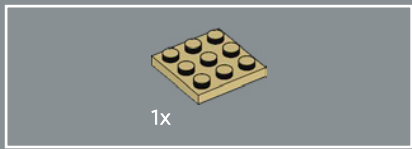

1x

60

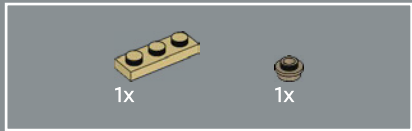

1x

1x

61

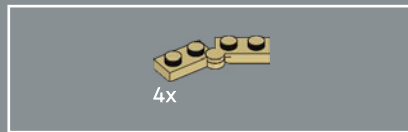
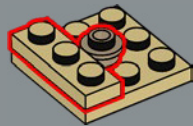

4x

62

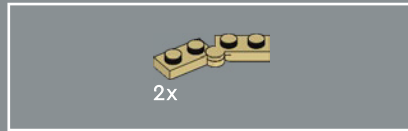
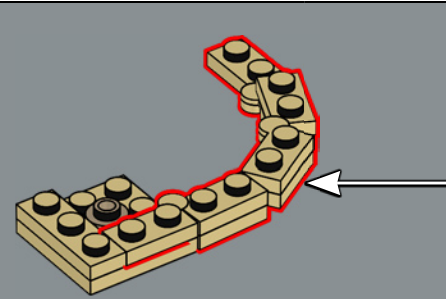
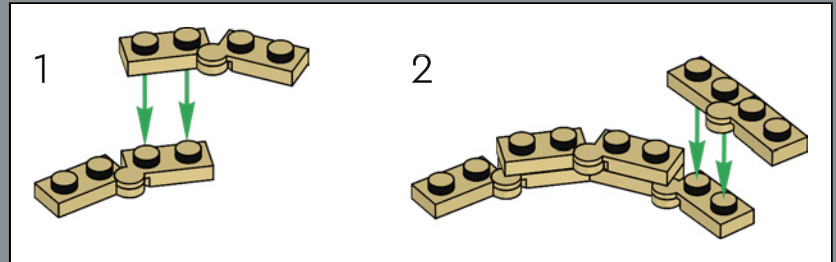

2x

63

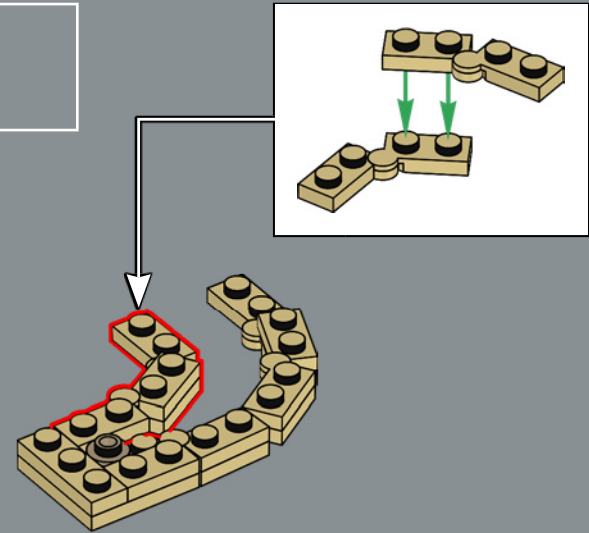





64

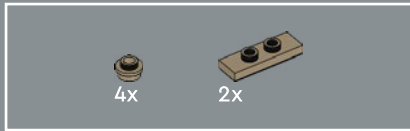
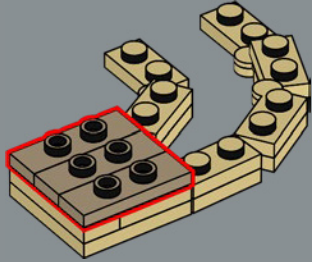

65

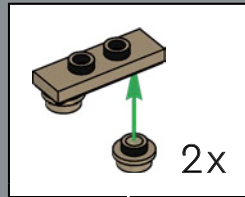
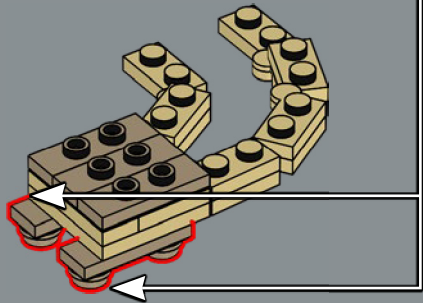

66

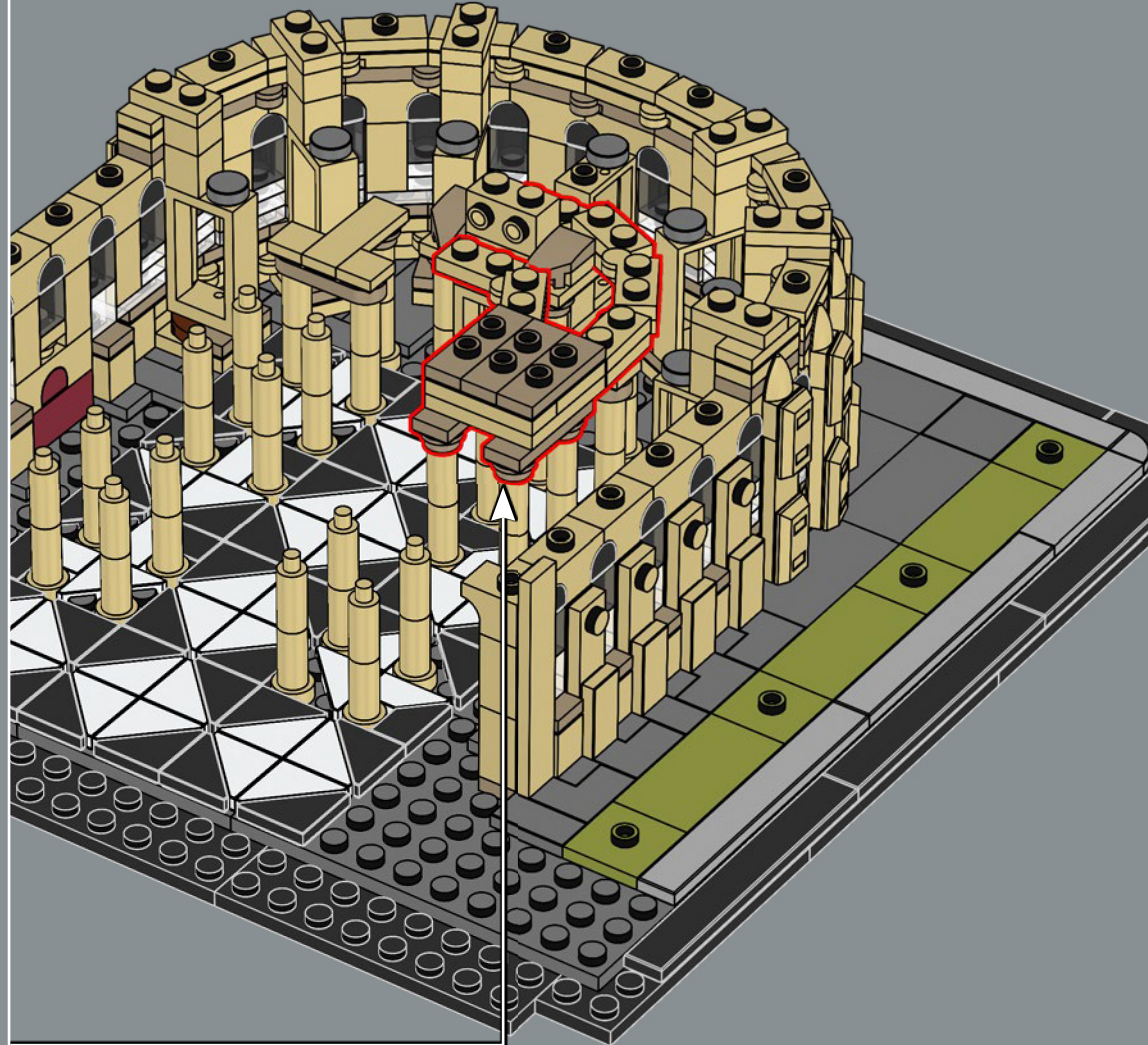

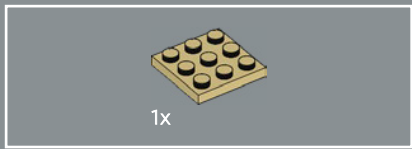

67

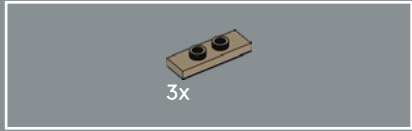
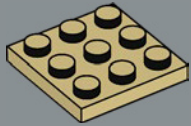

68

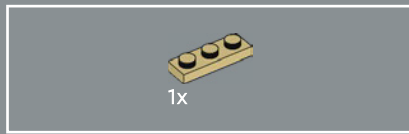
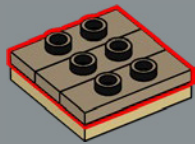

69

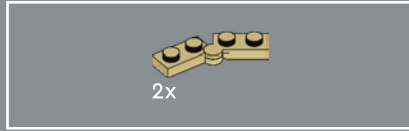
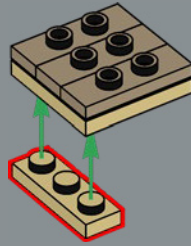

70

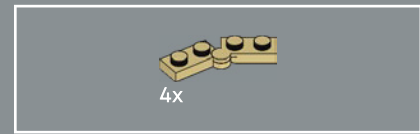
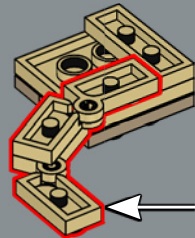
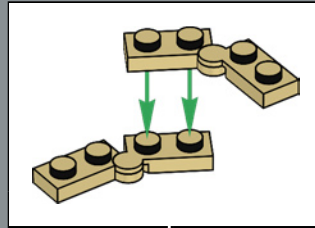

71

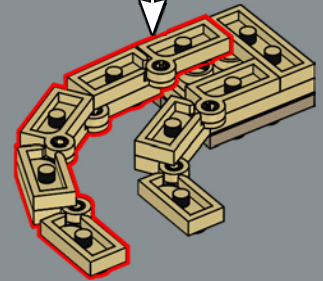
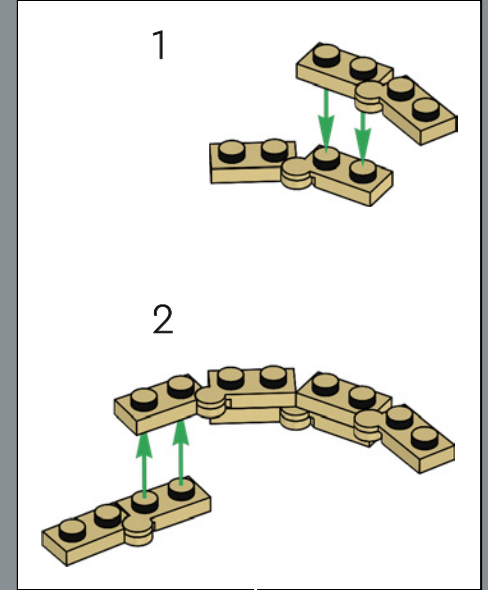

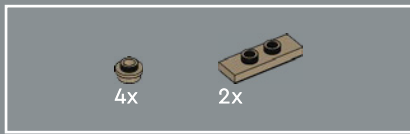

72

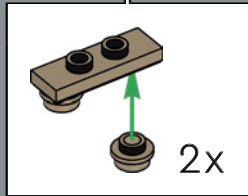
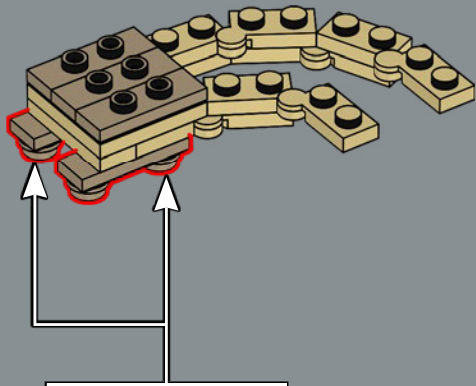

73

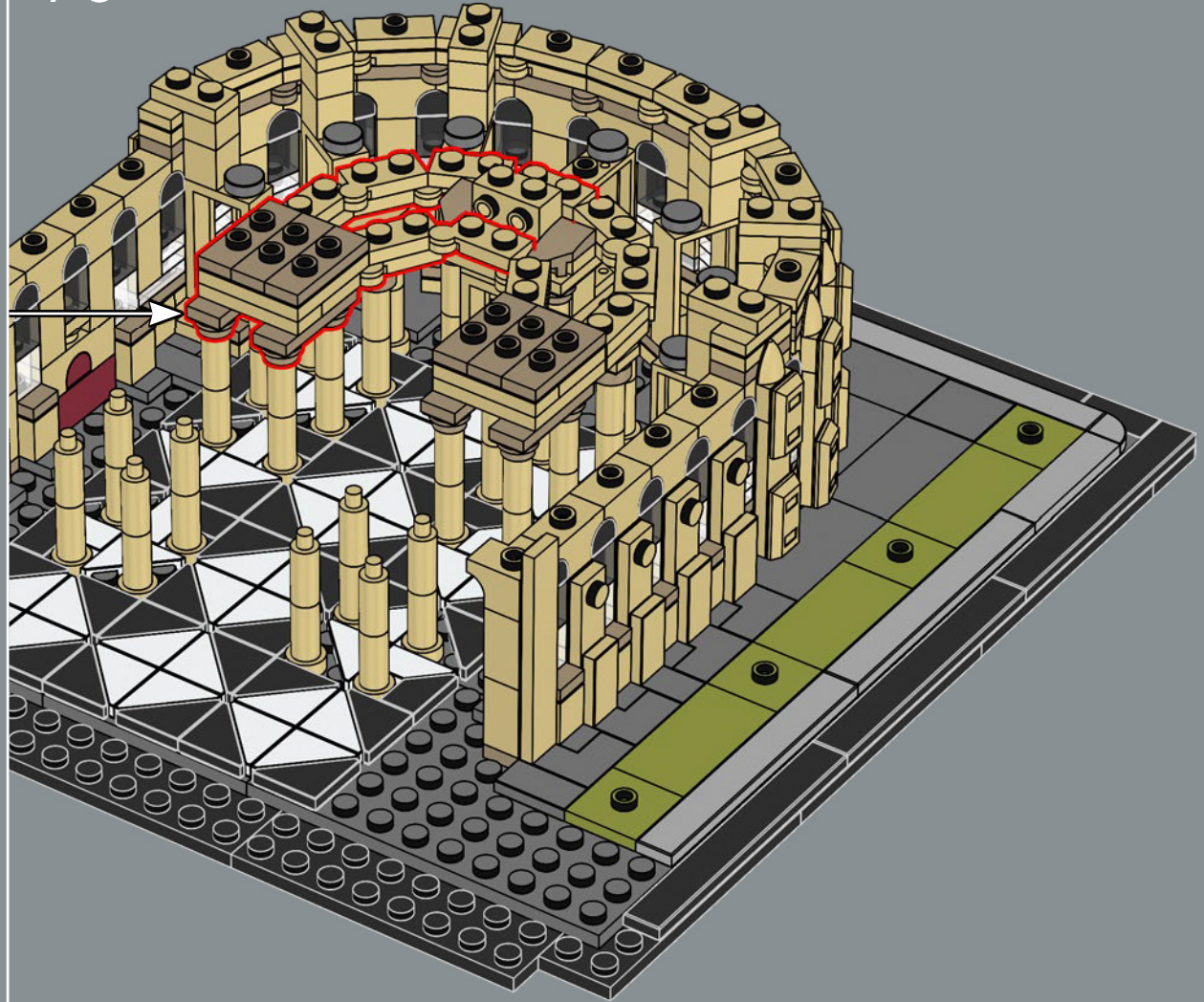

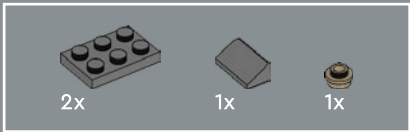

74

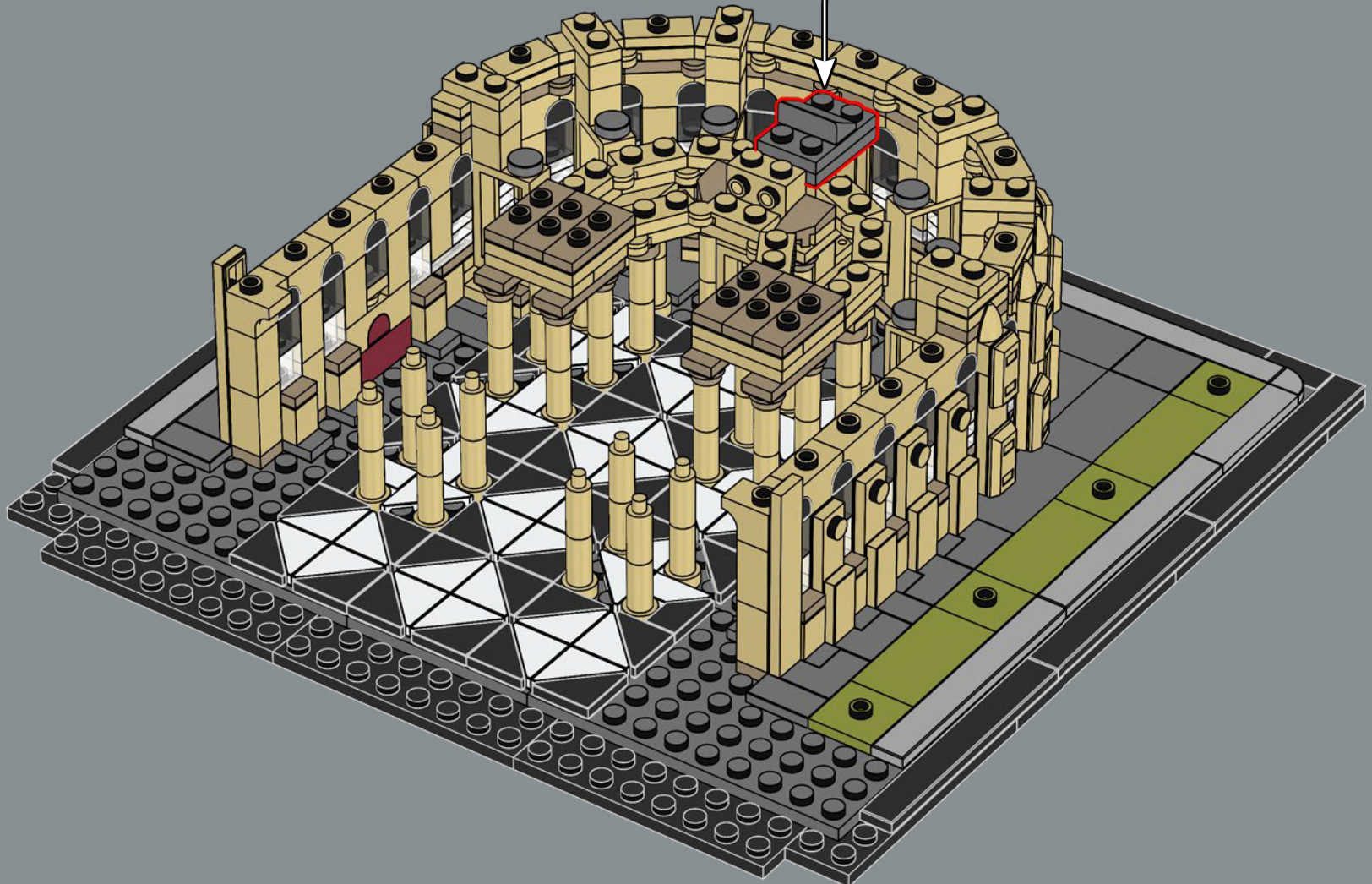
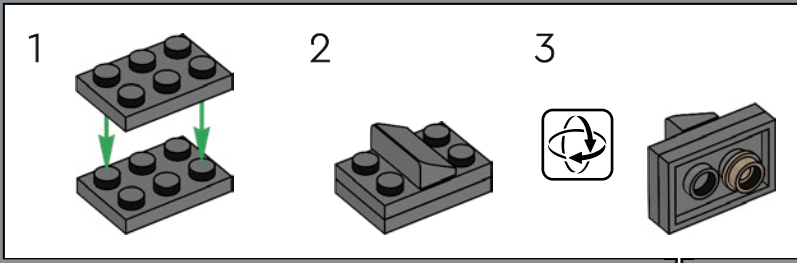

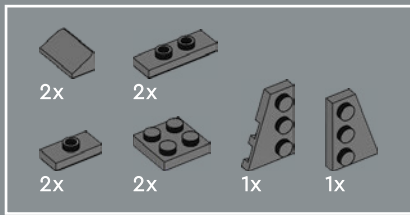

75

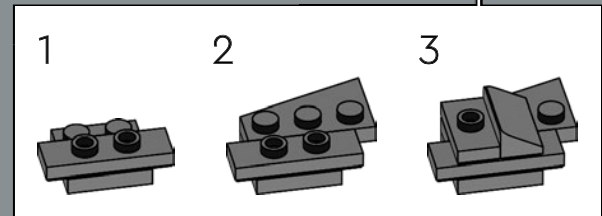
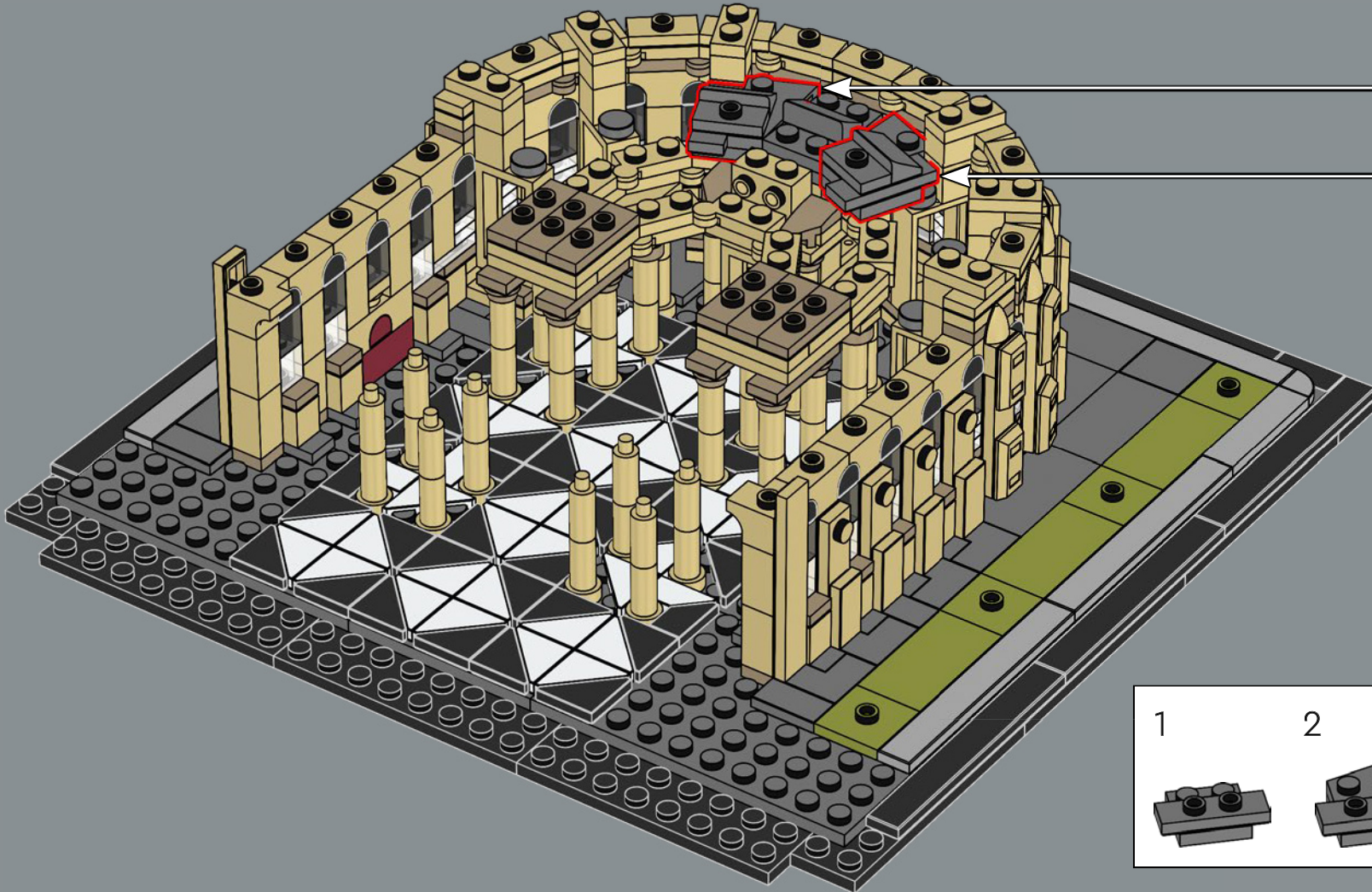
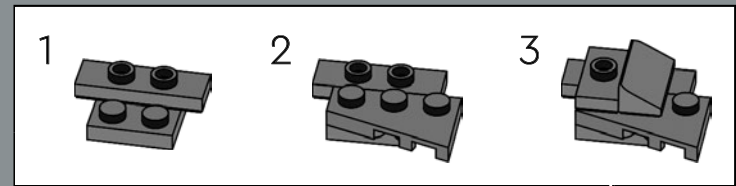

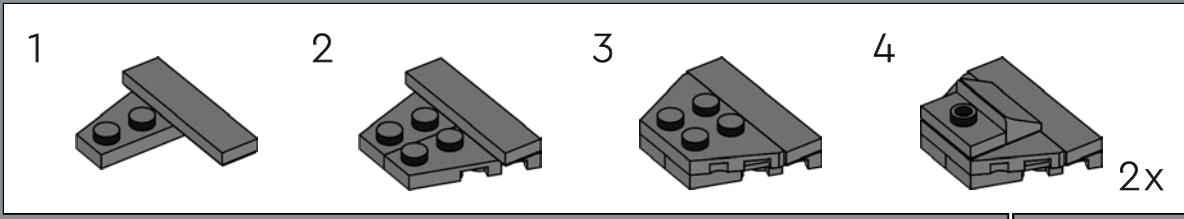
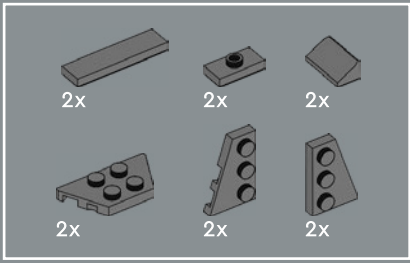

76

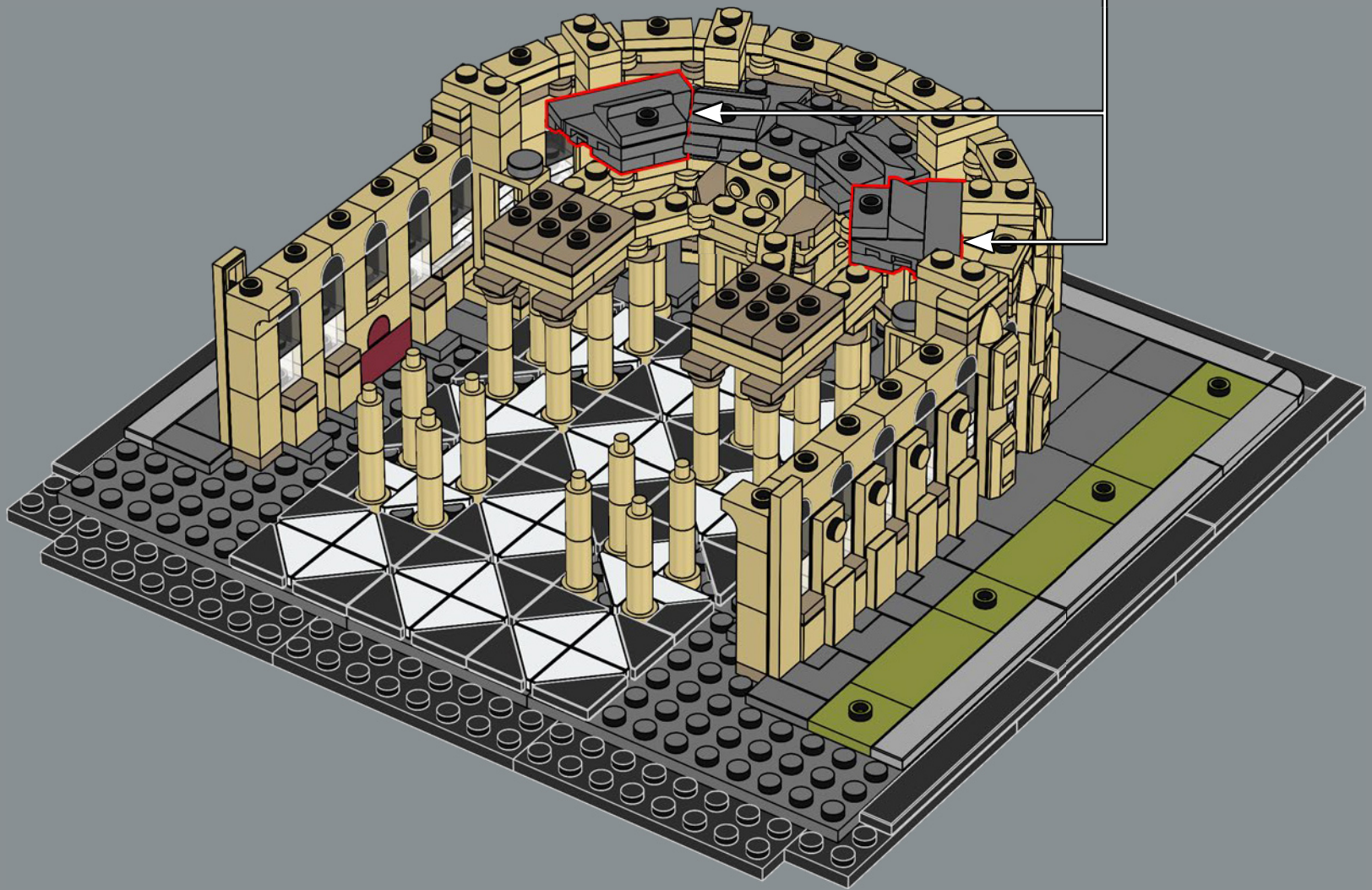

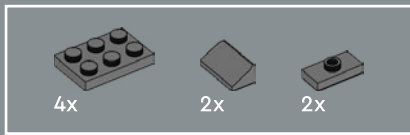

77

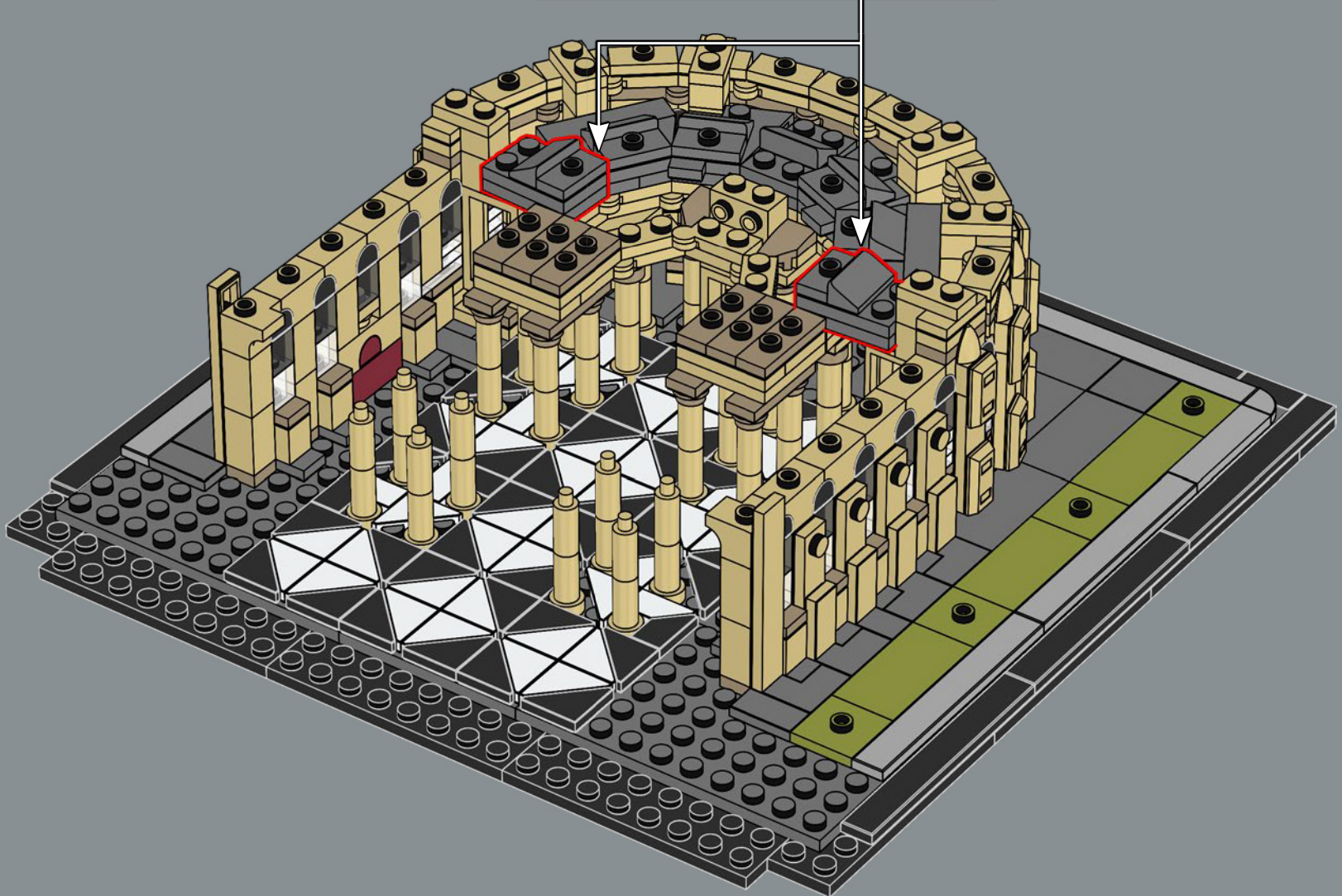
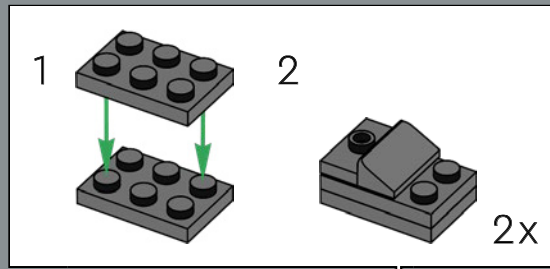



78

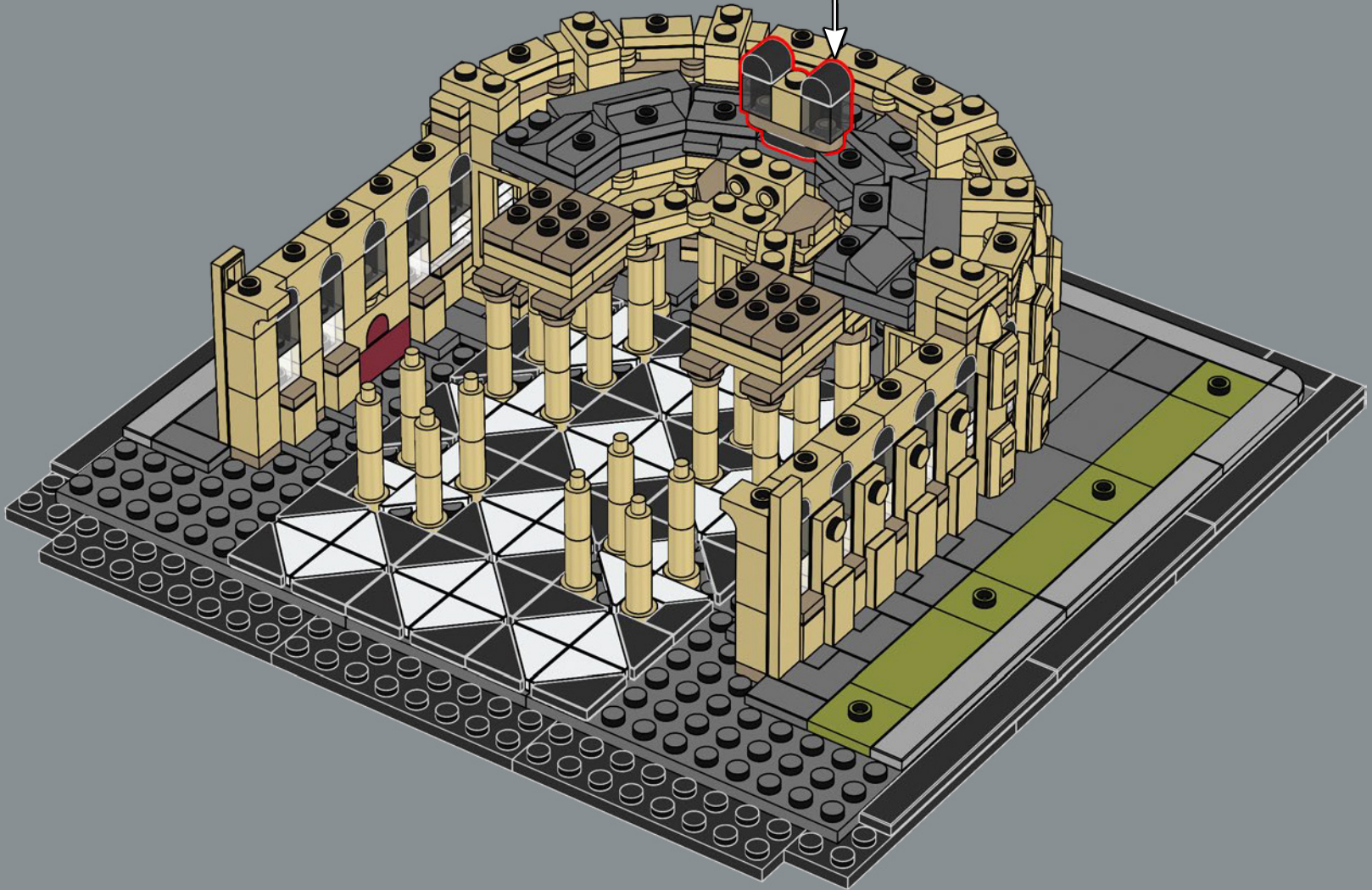
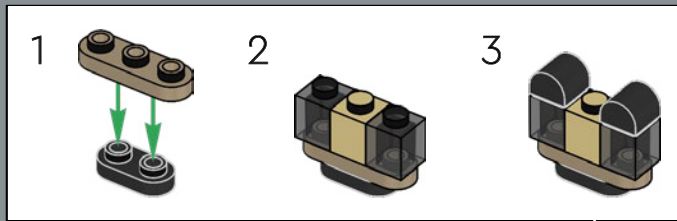





79

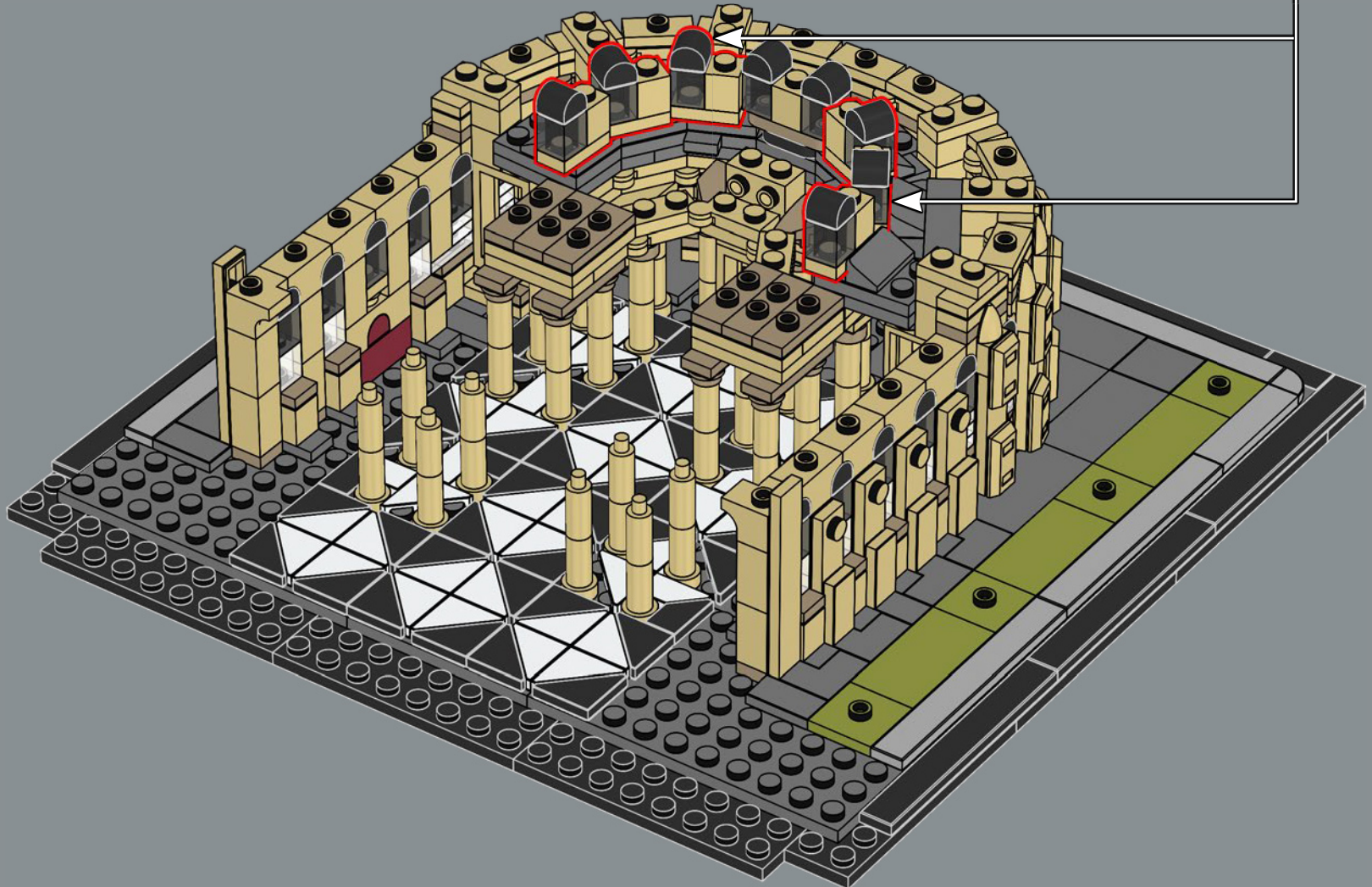
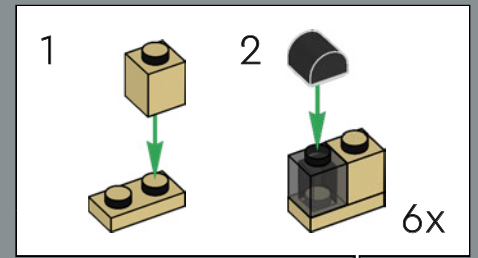



7x

80

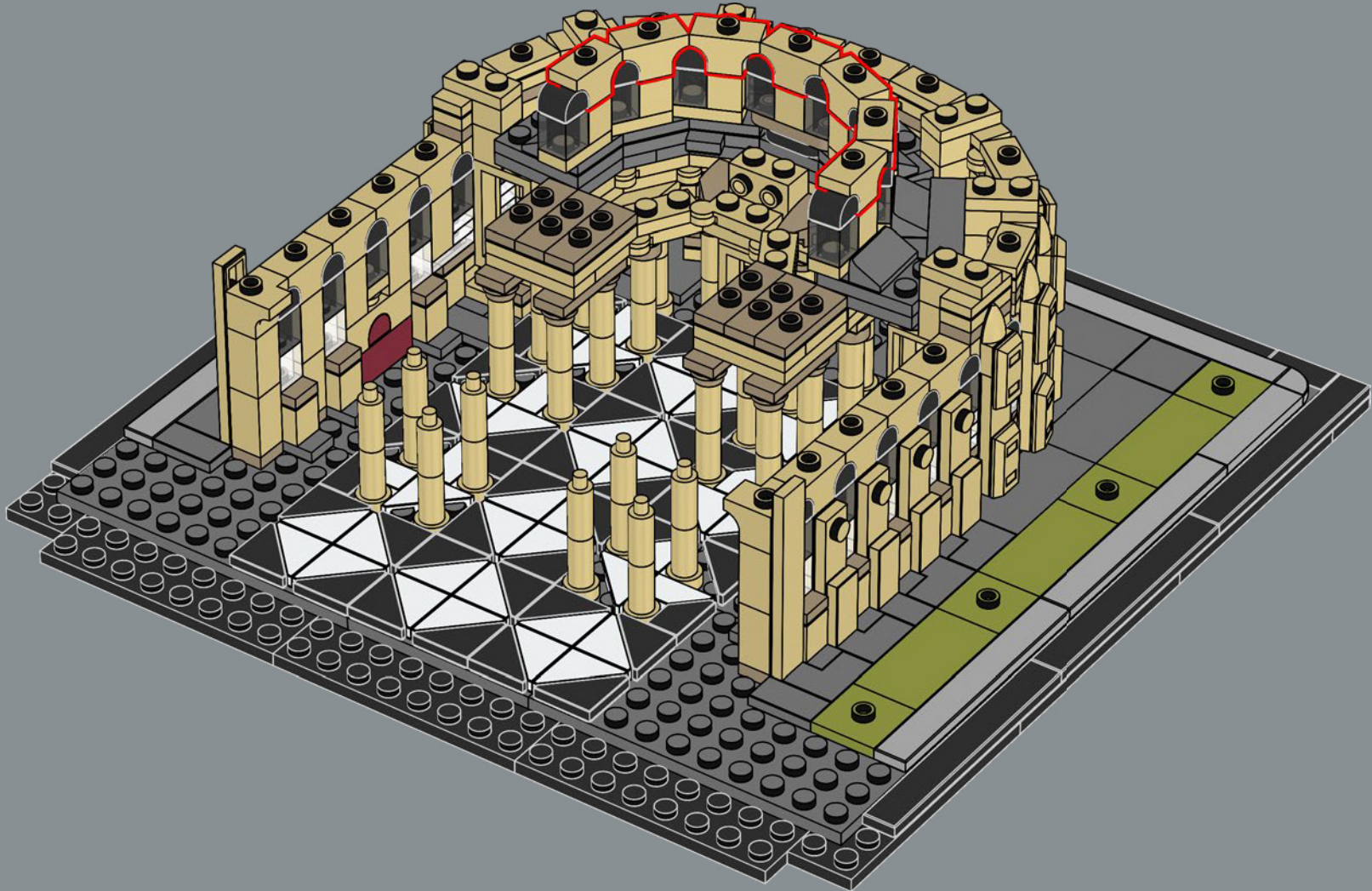

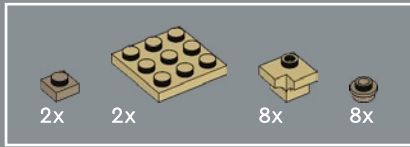

81

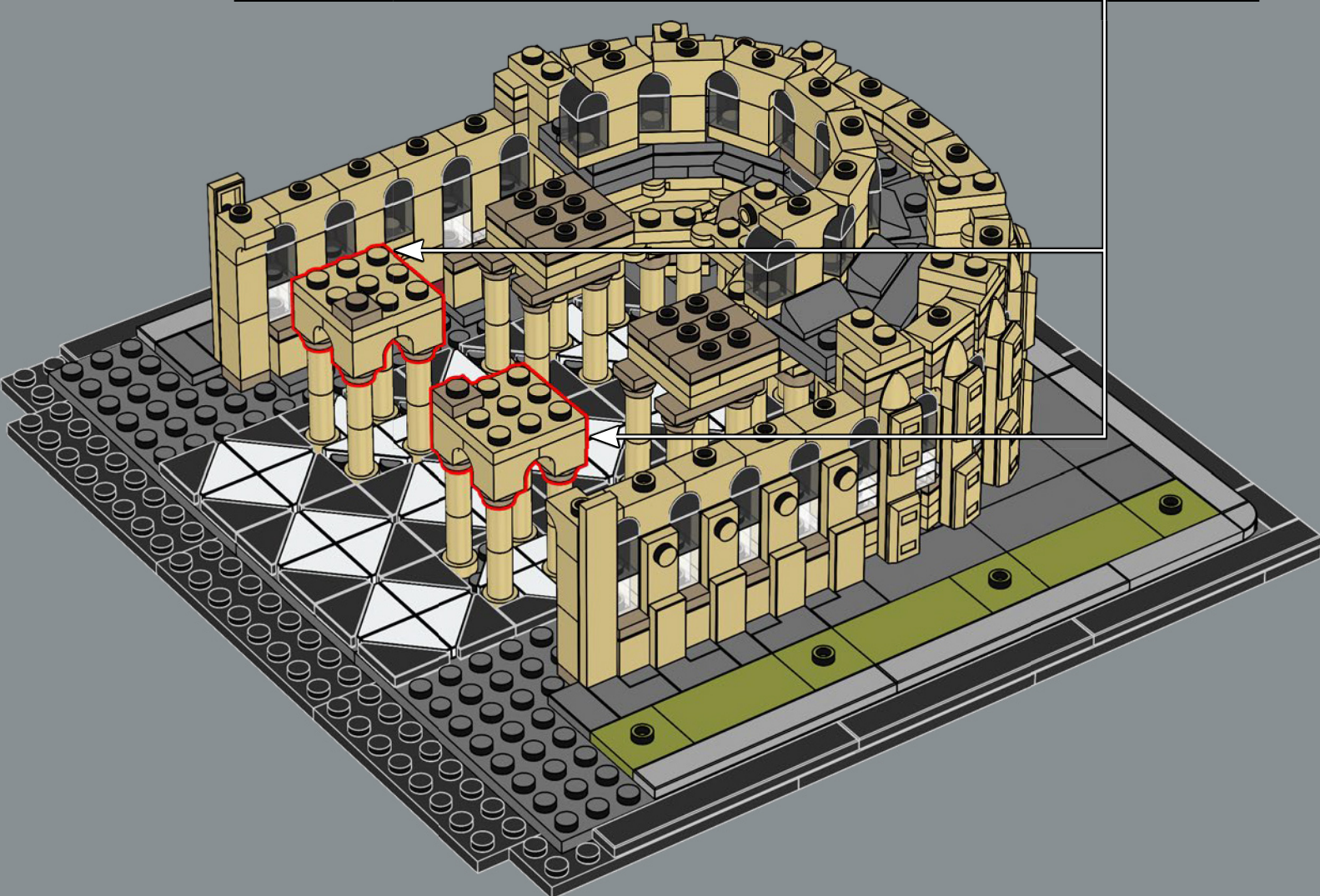
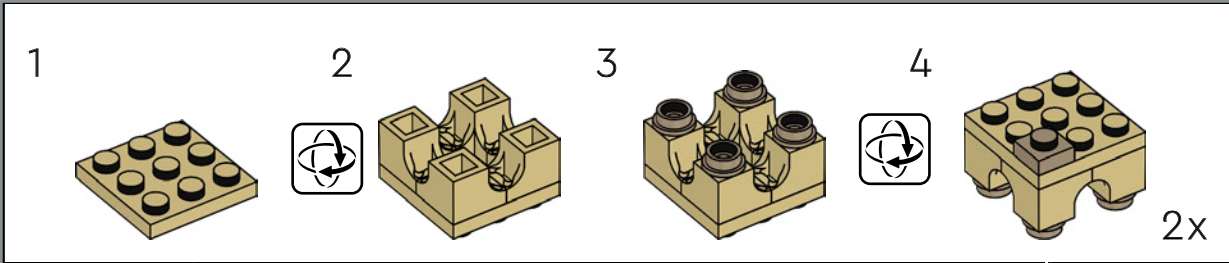

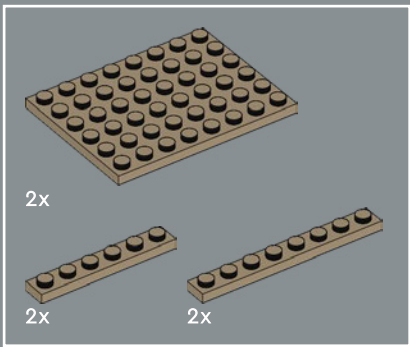

82

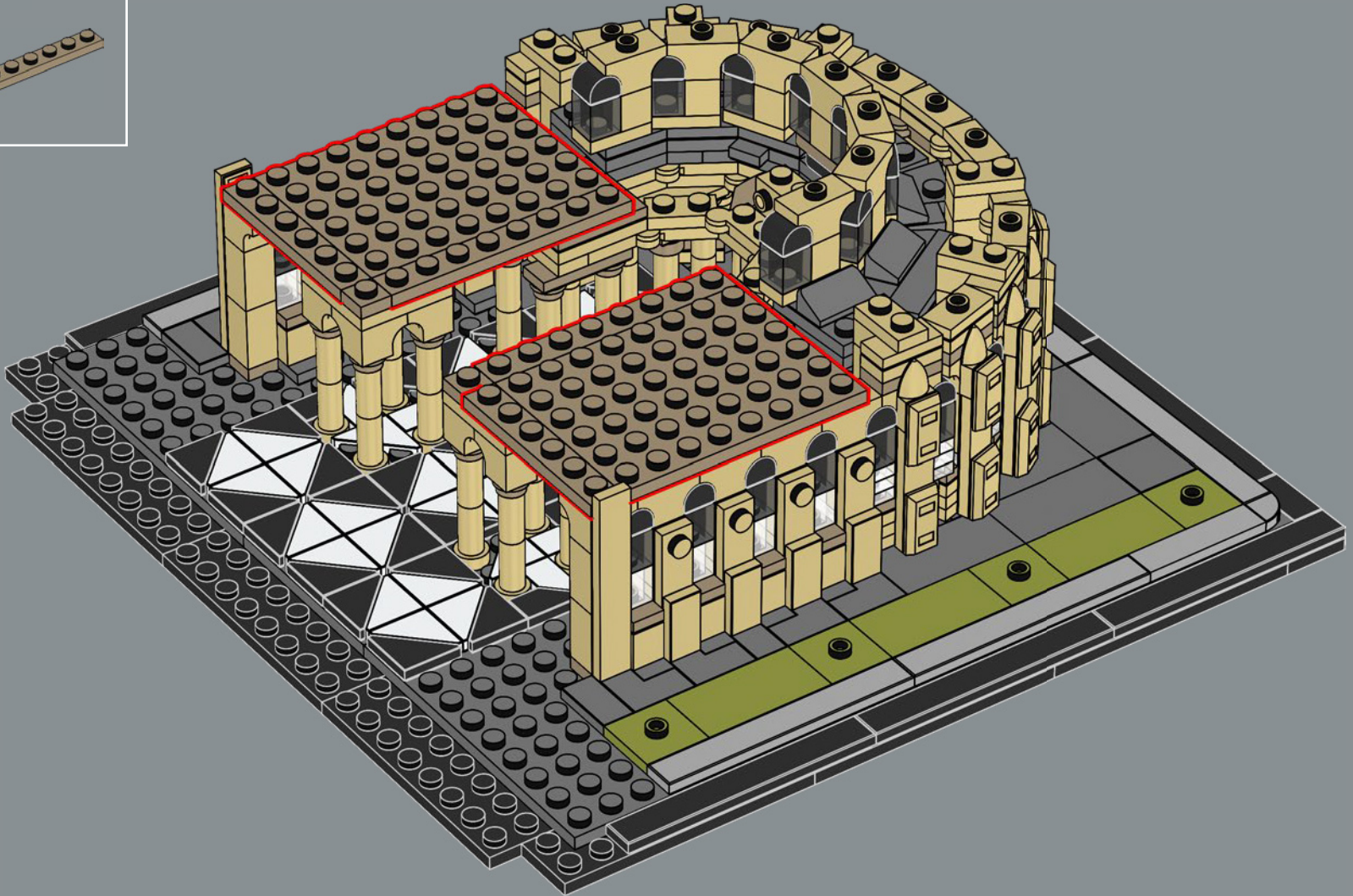



83

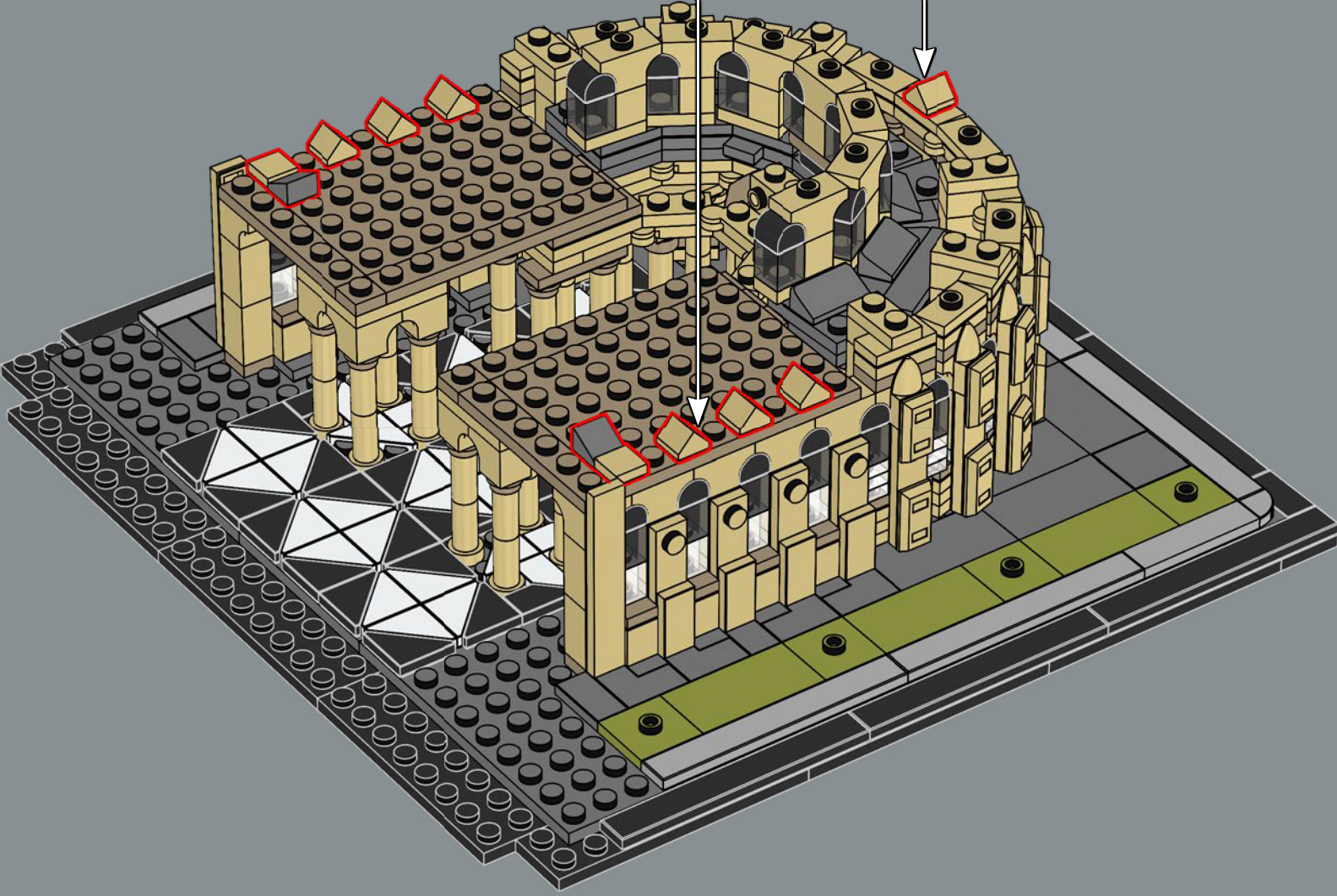

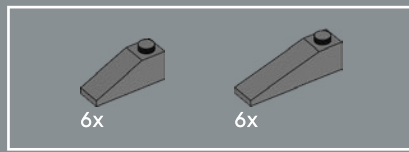

84

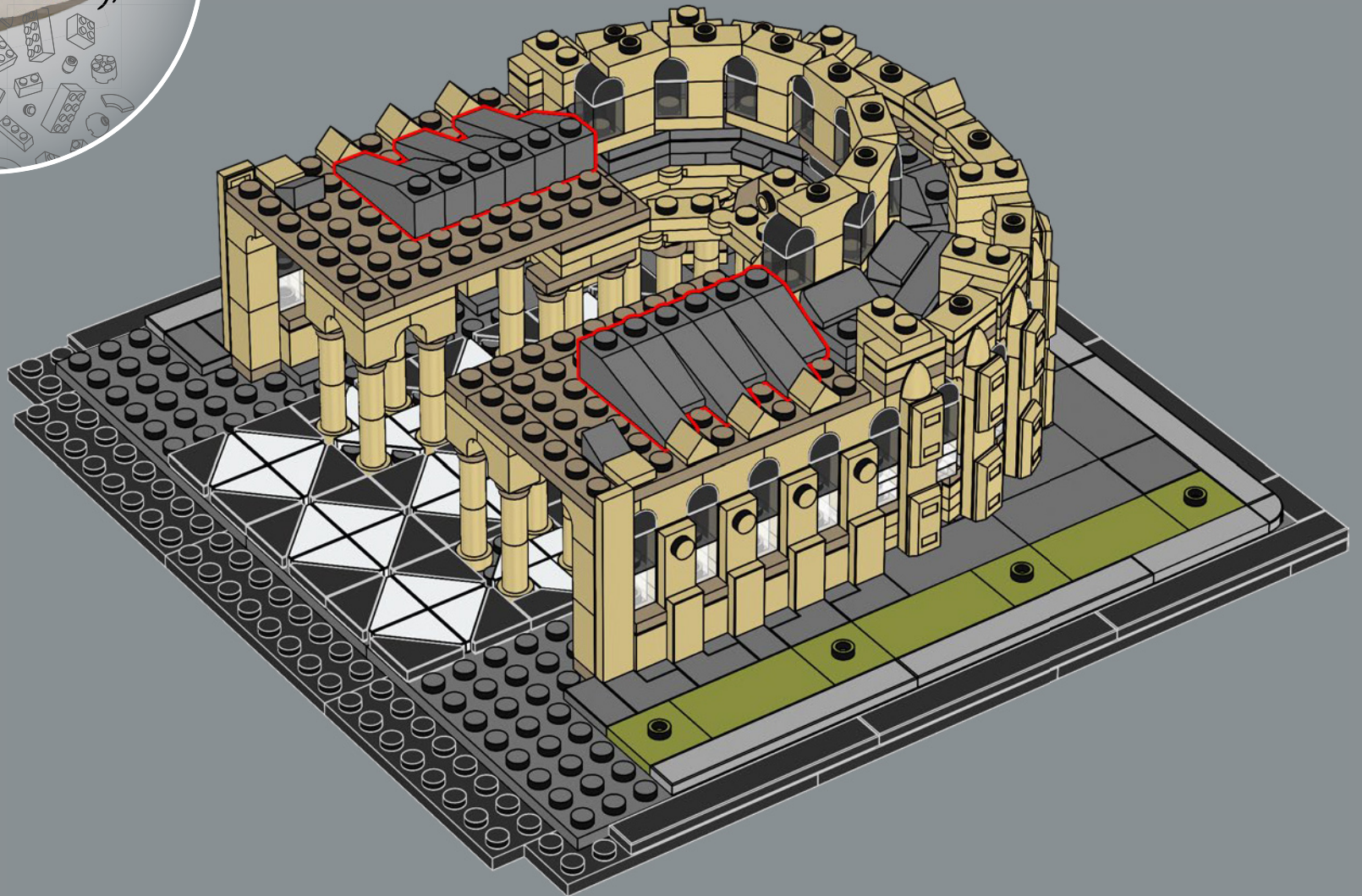

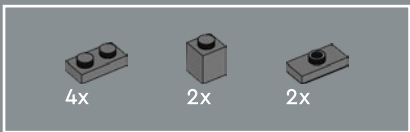

85

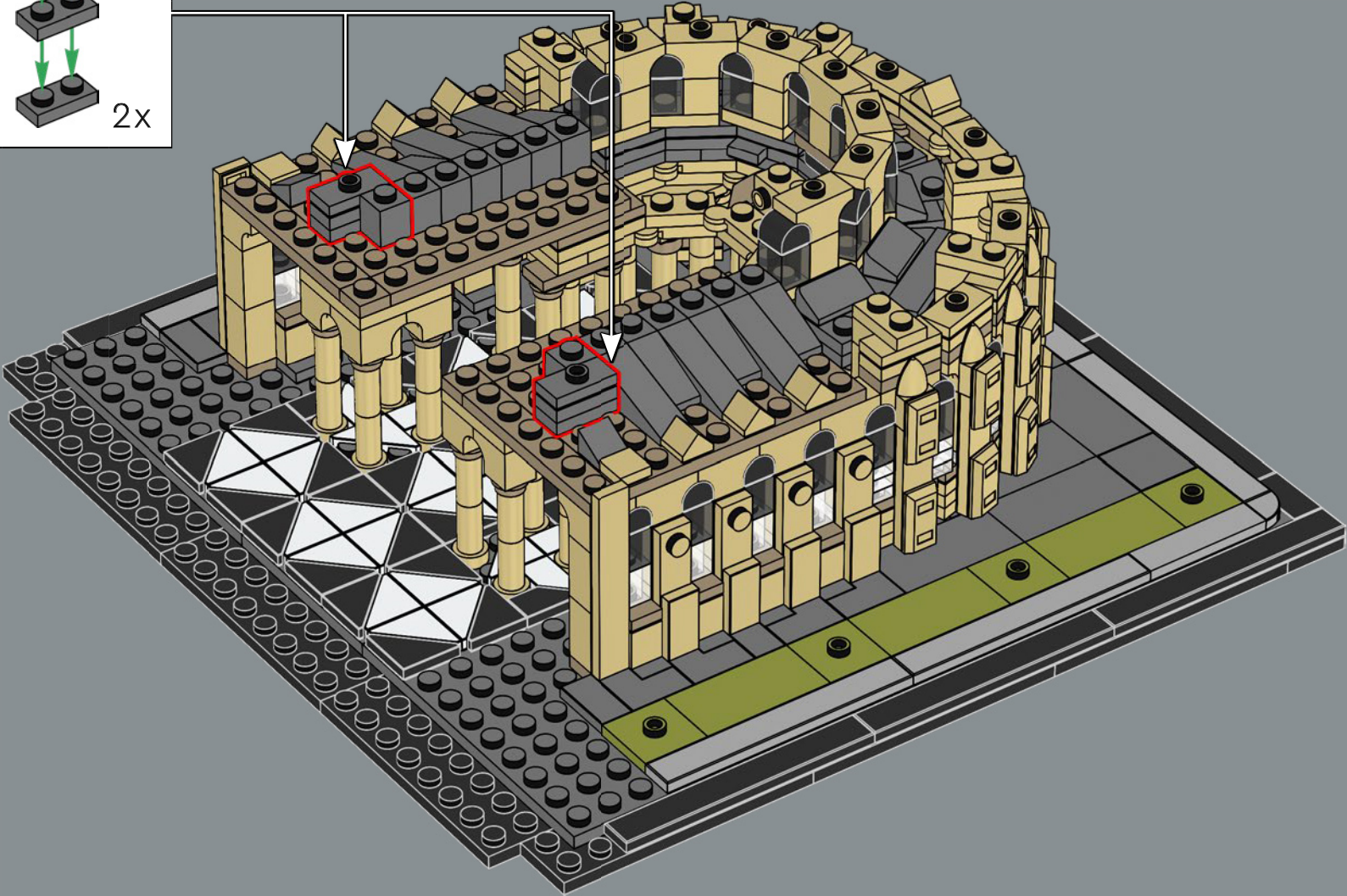
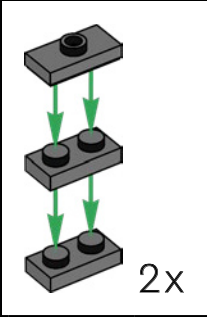



12x

86

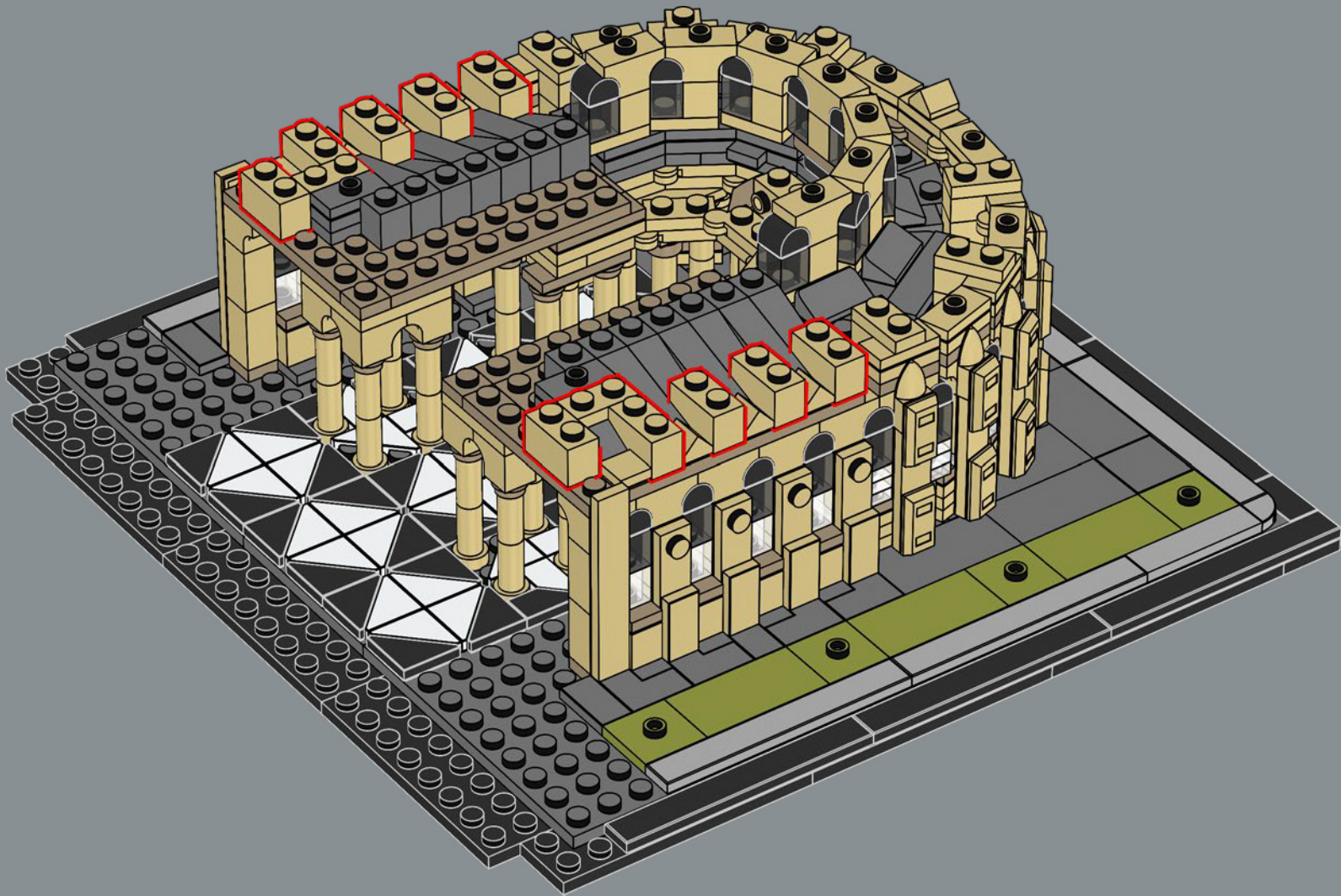



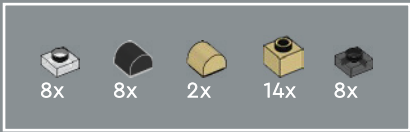

87

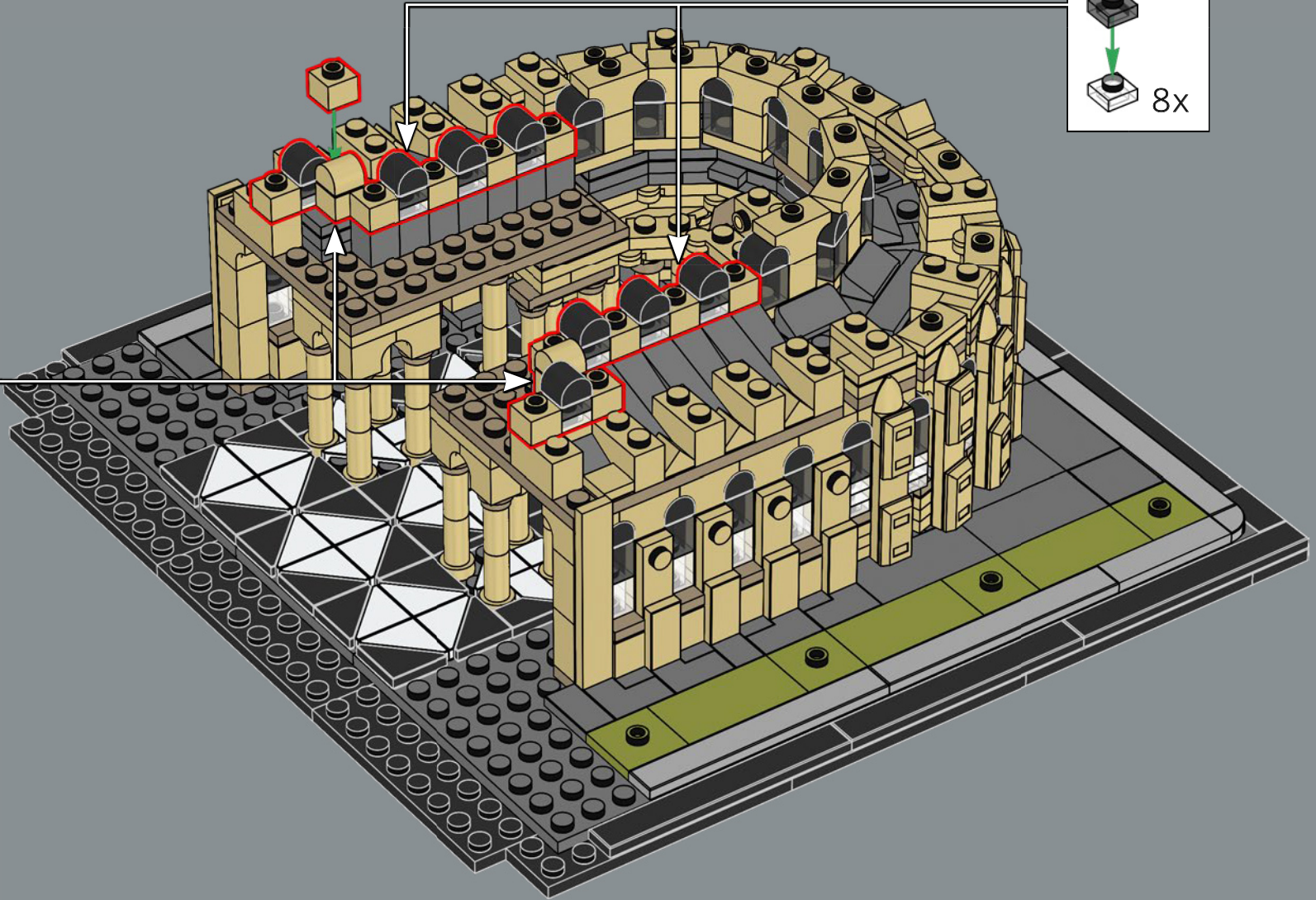
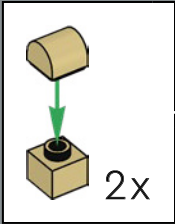
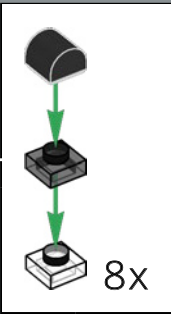

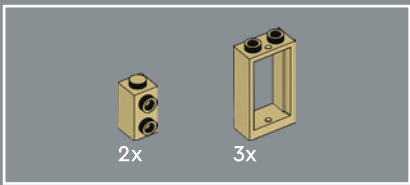

88

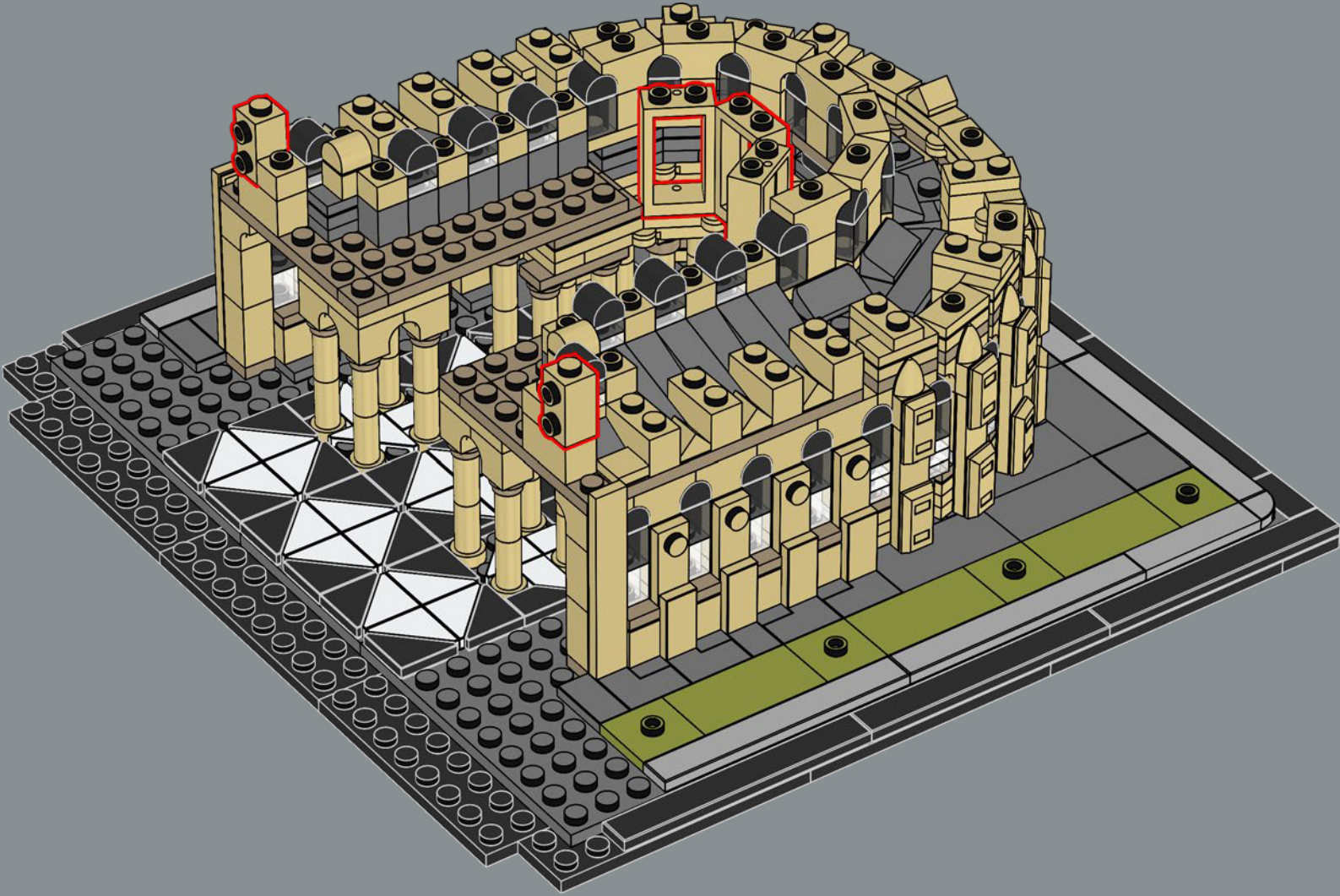

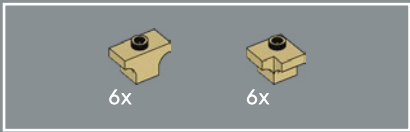

89

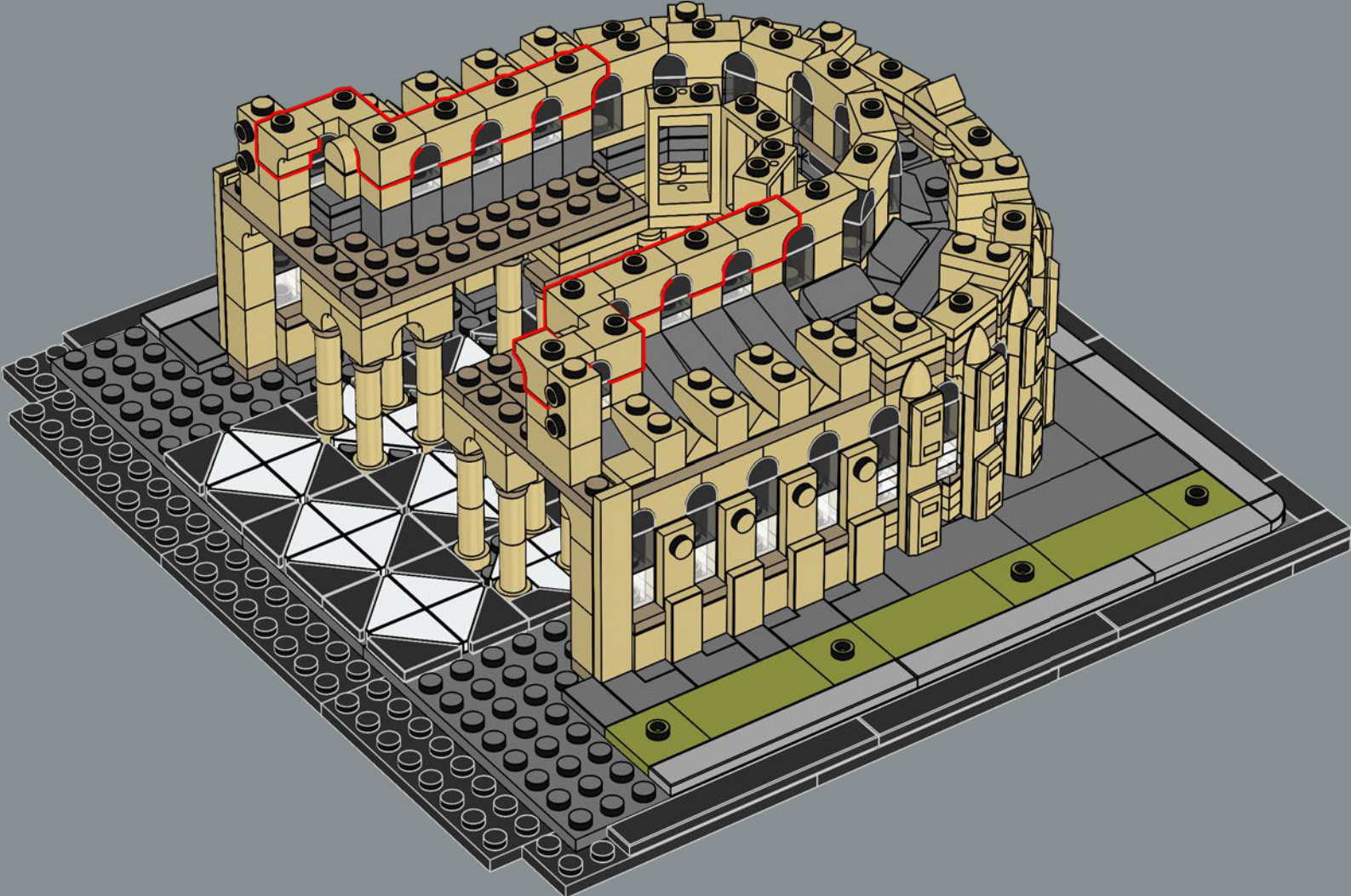

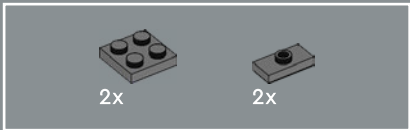

90

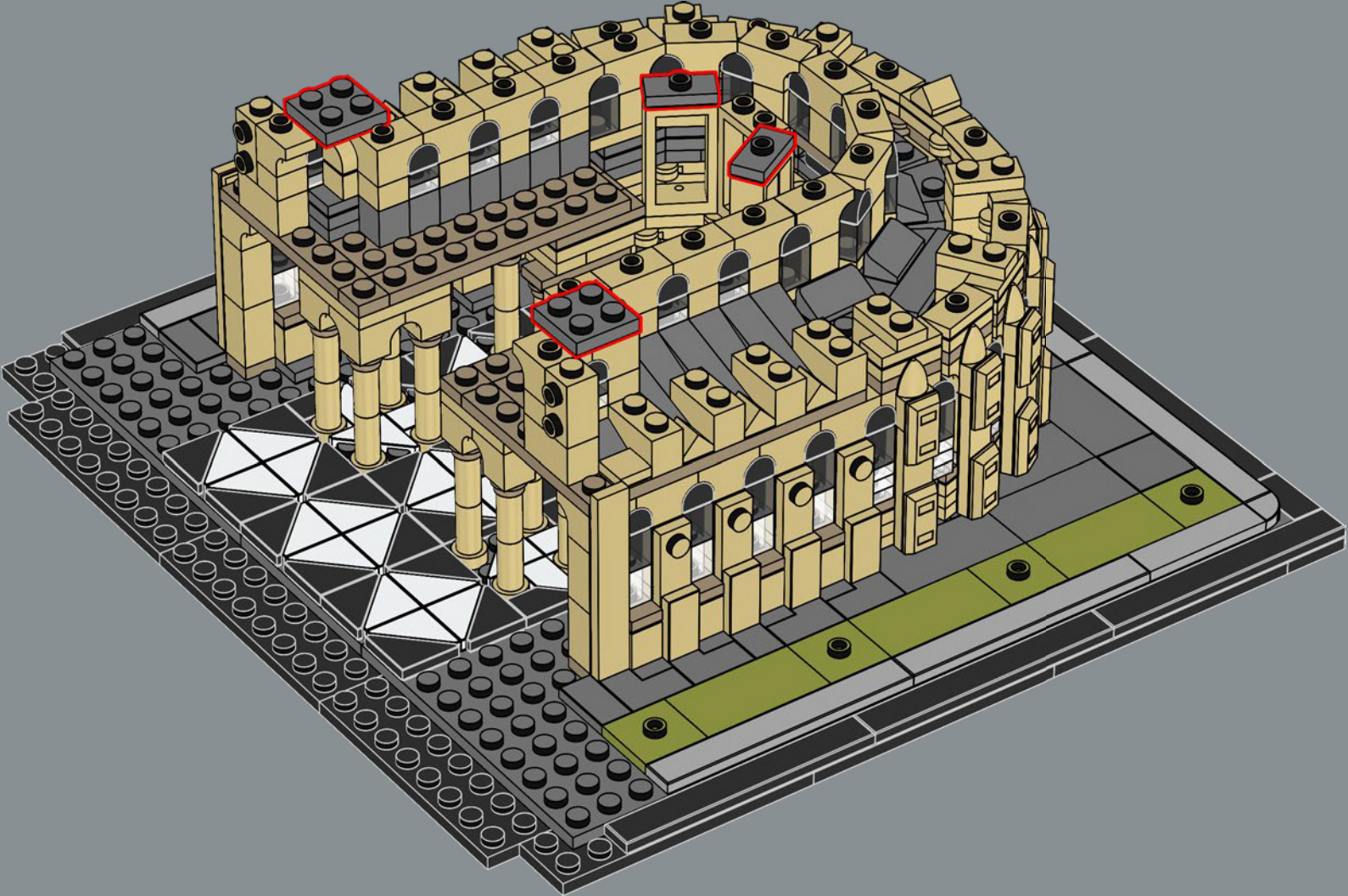

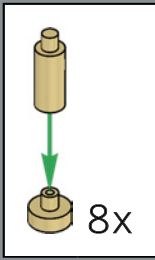

91

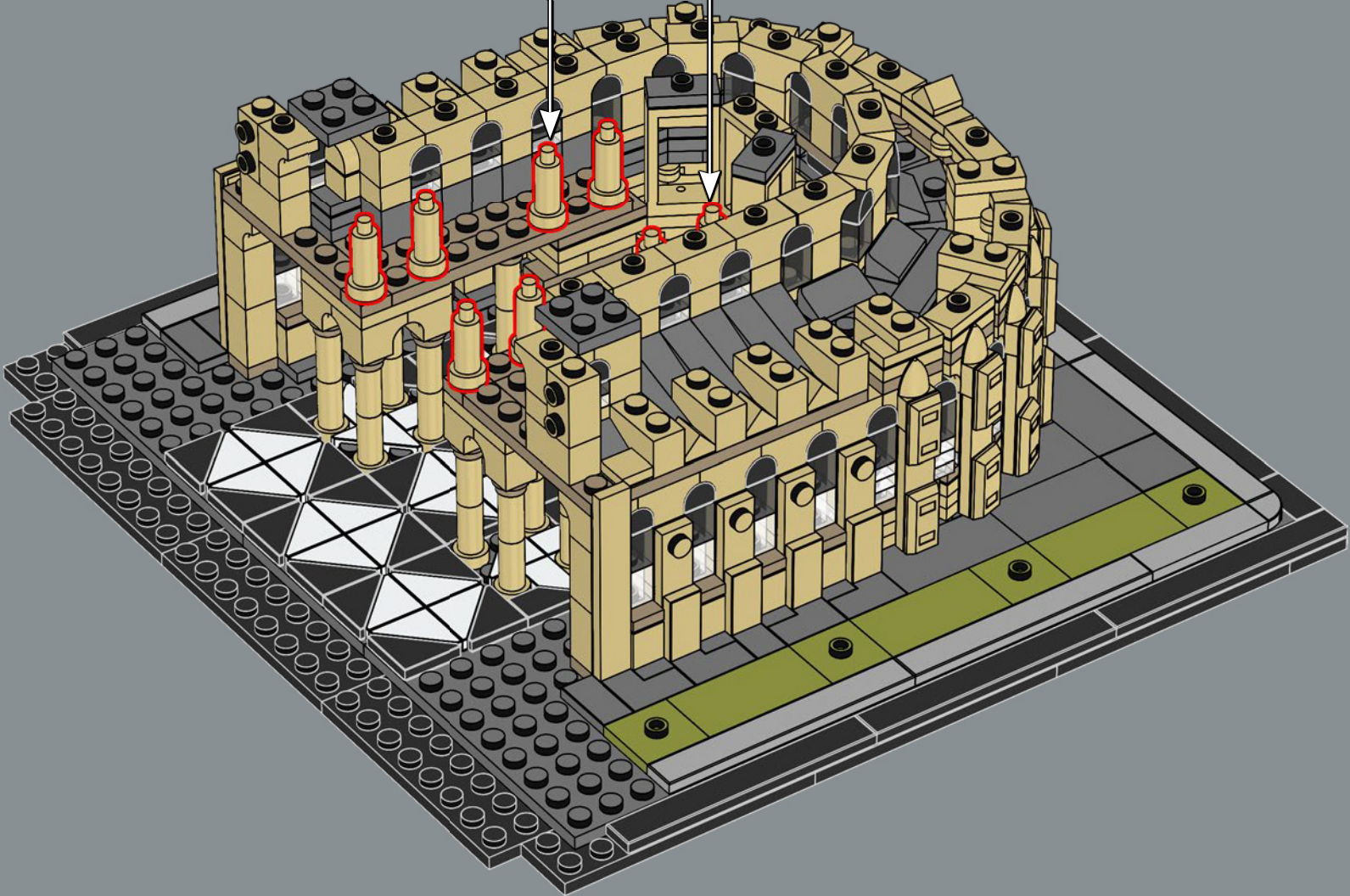

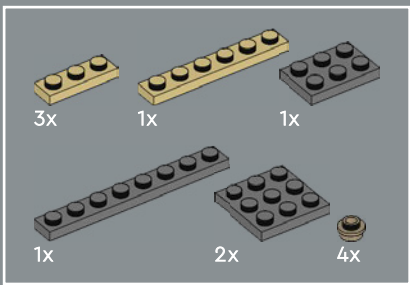

92

1

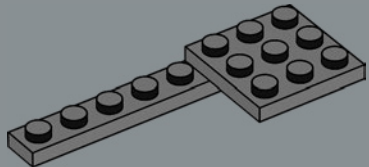

2

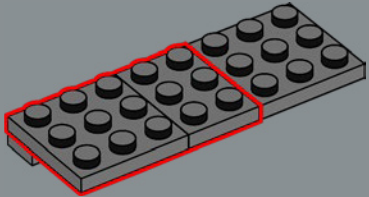

3

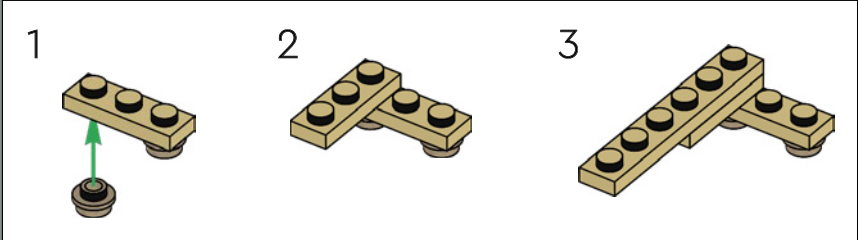
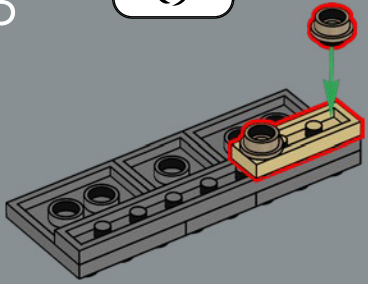

4

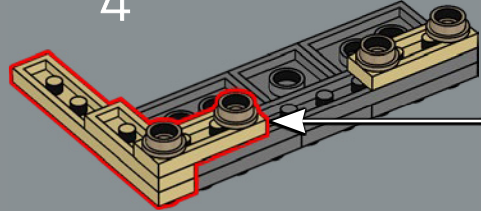

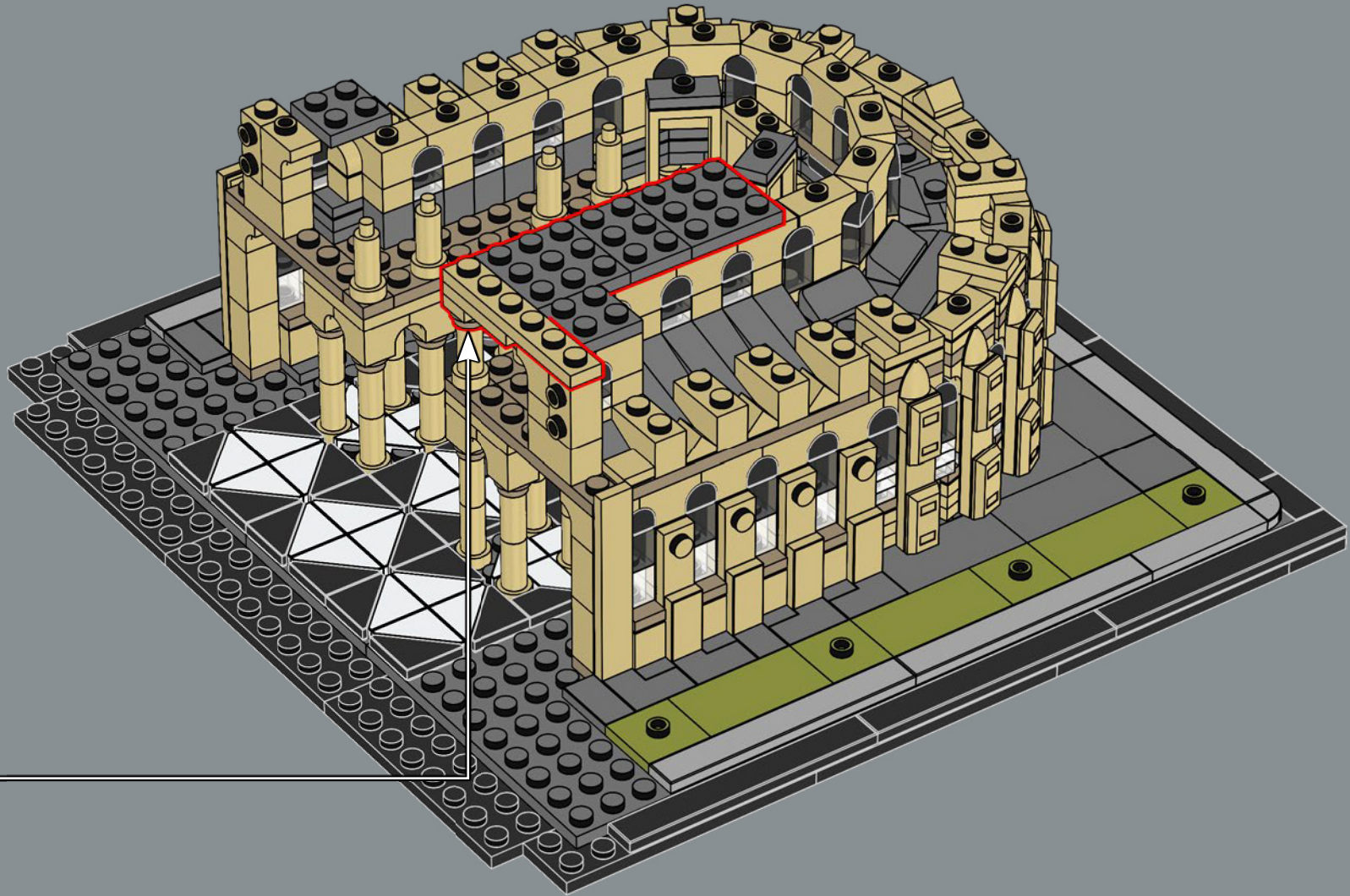

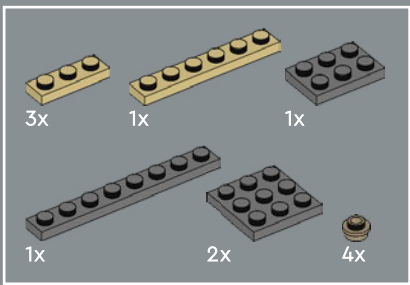

93

1

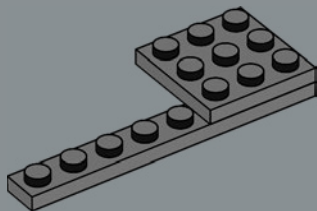

2

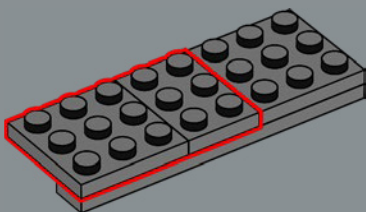

3

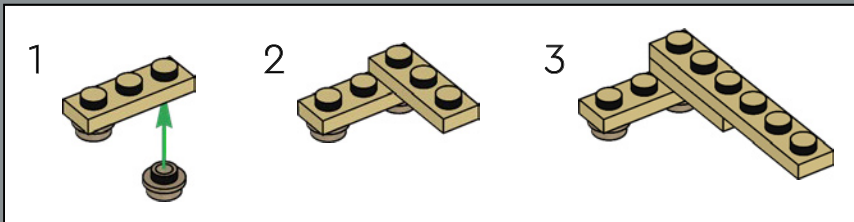
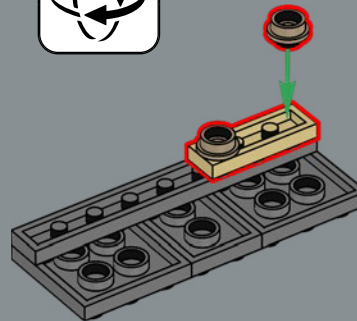

4

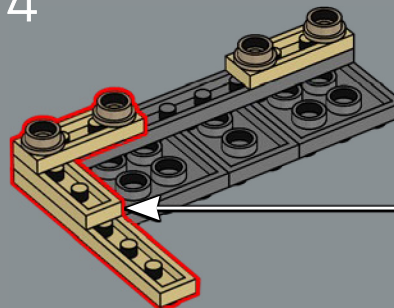



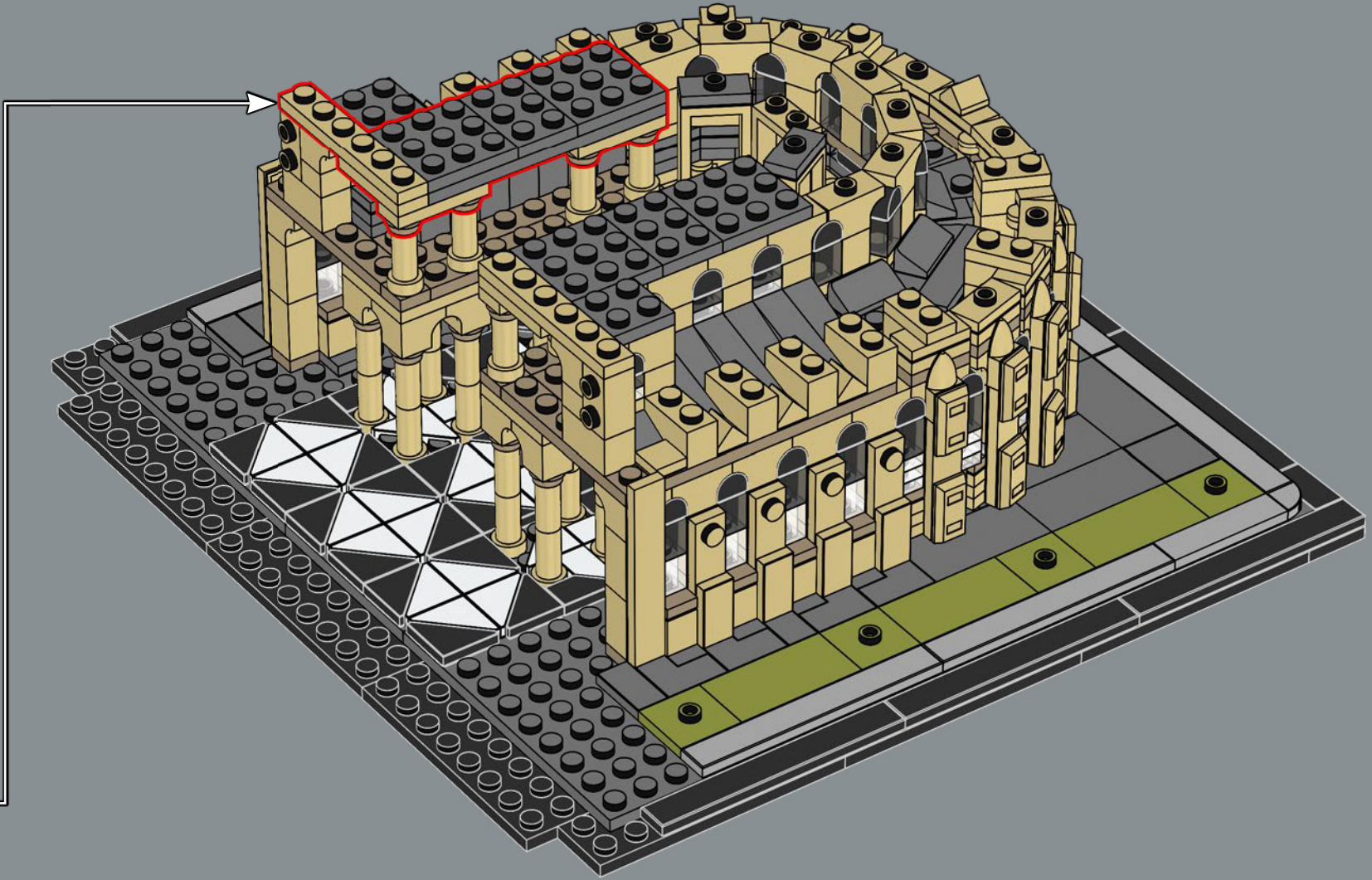



6x

94

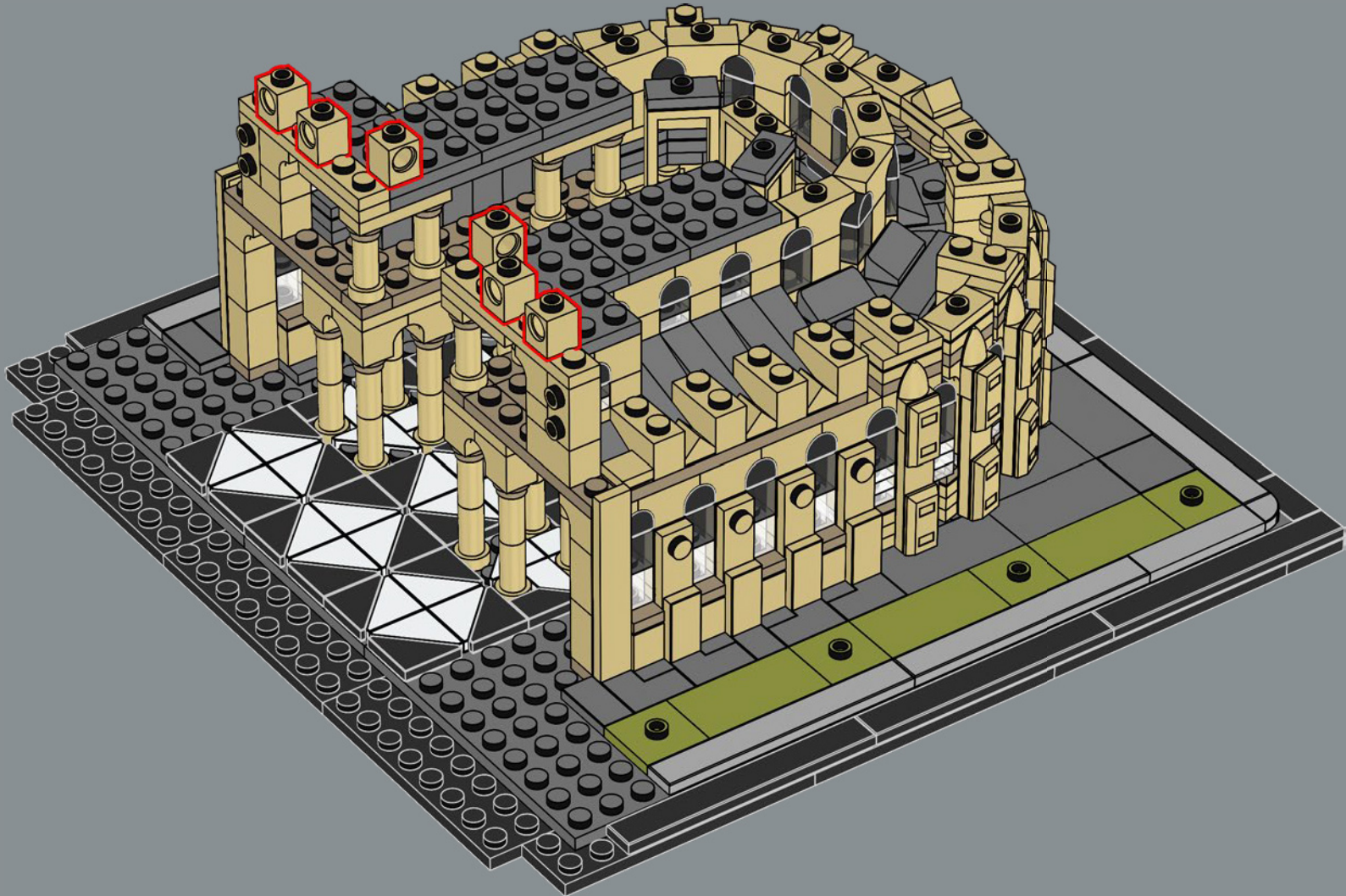

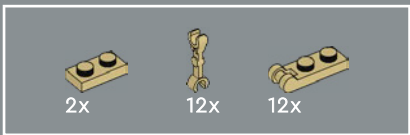

95

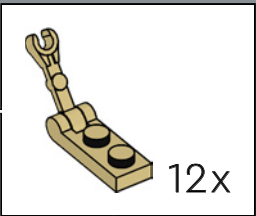
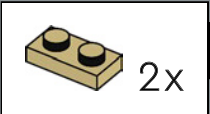

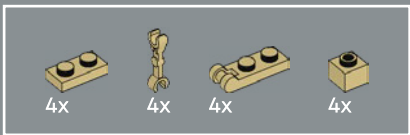

96

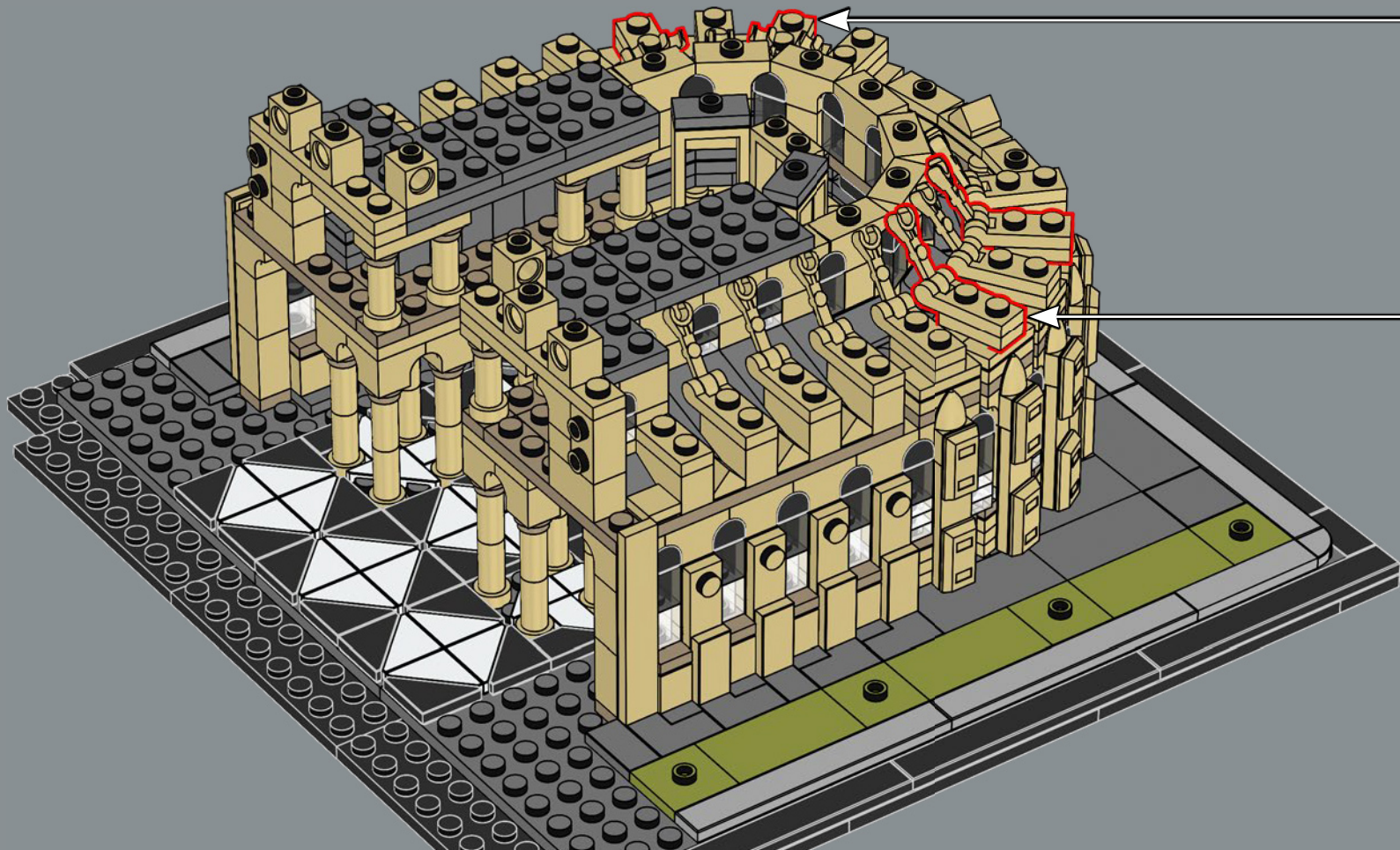
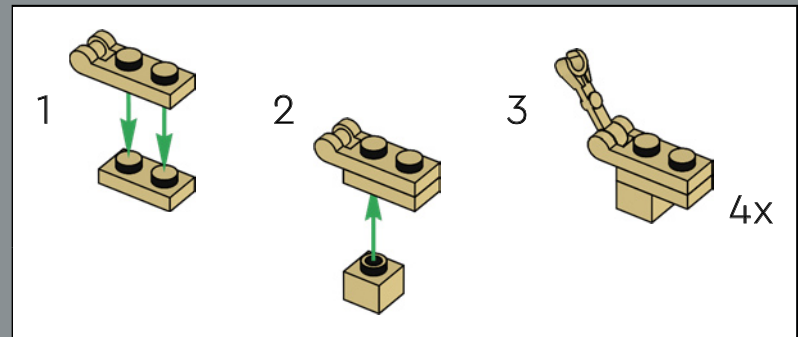

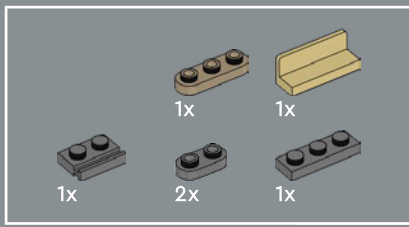

97

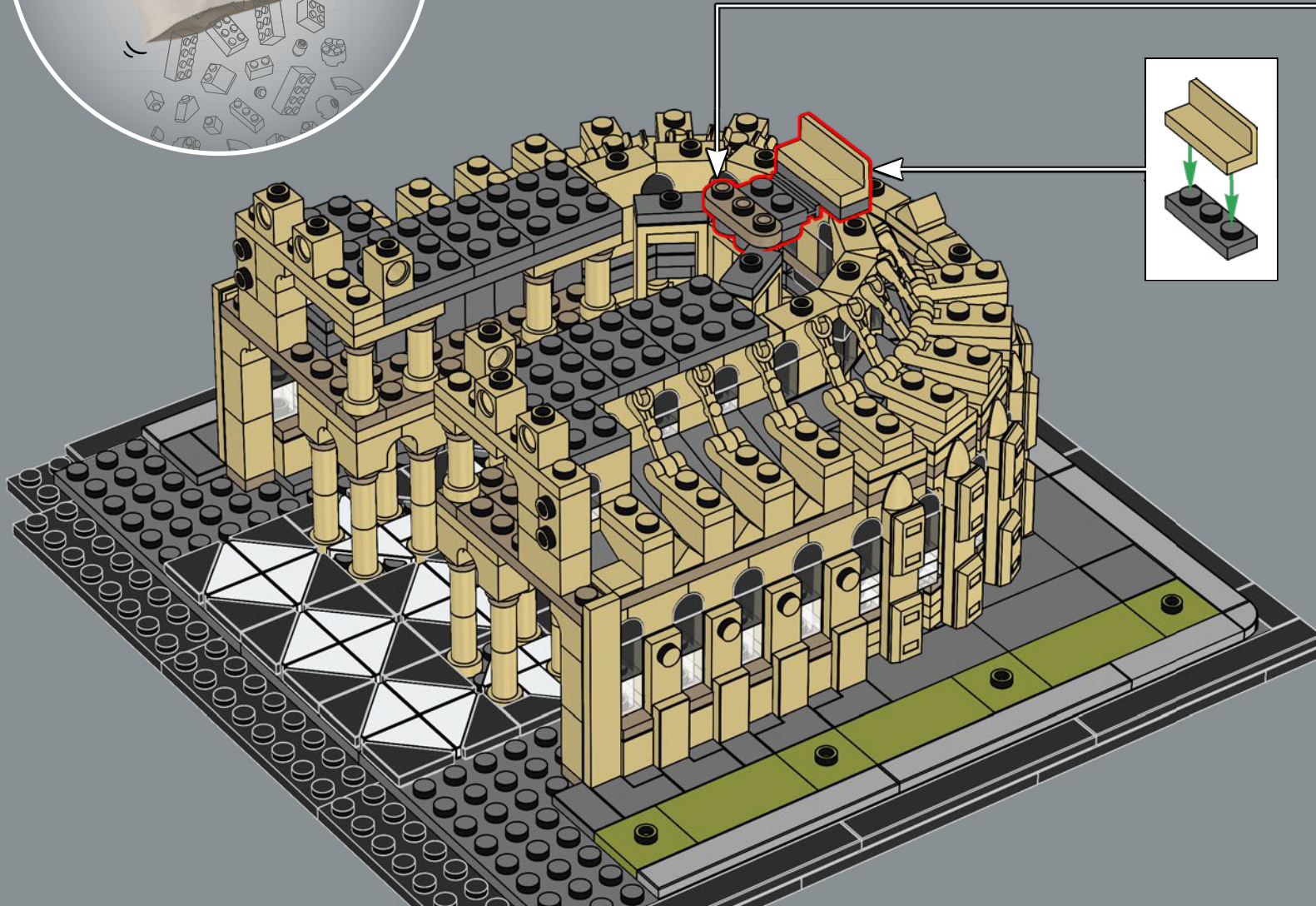
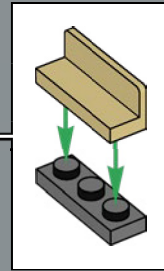
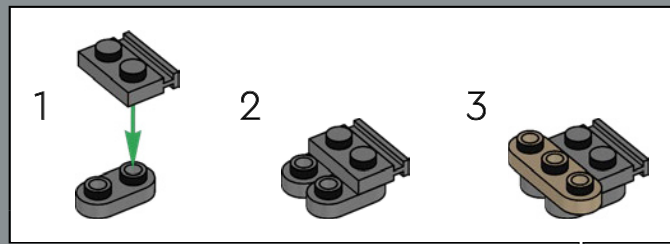



98

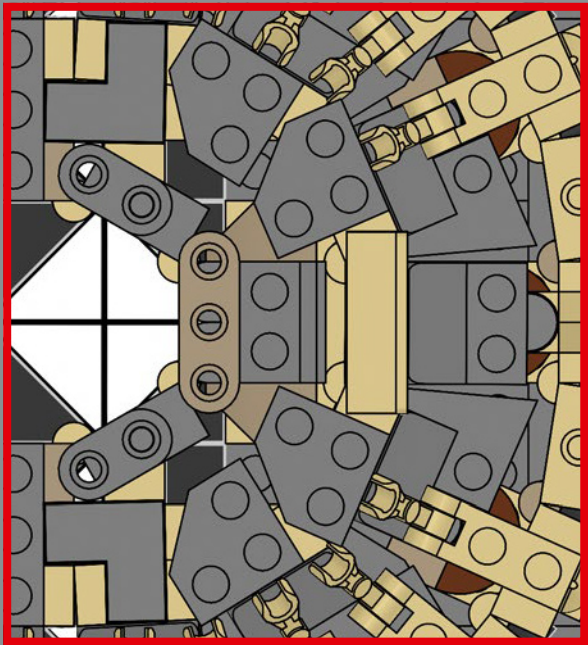
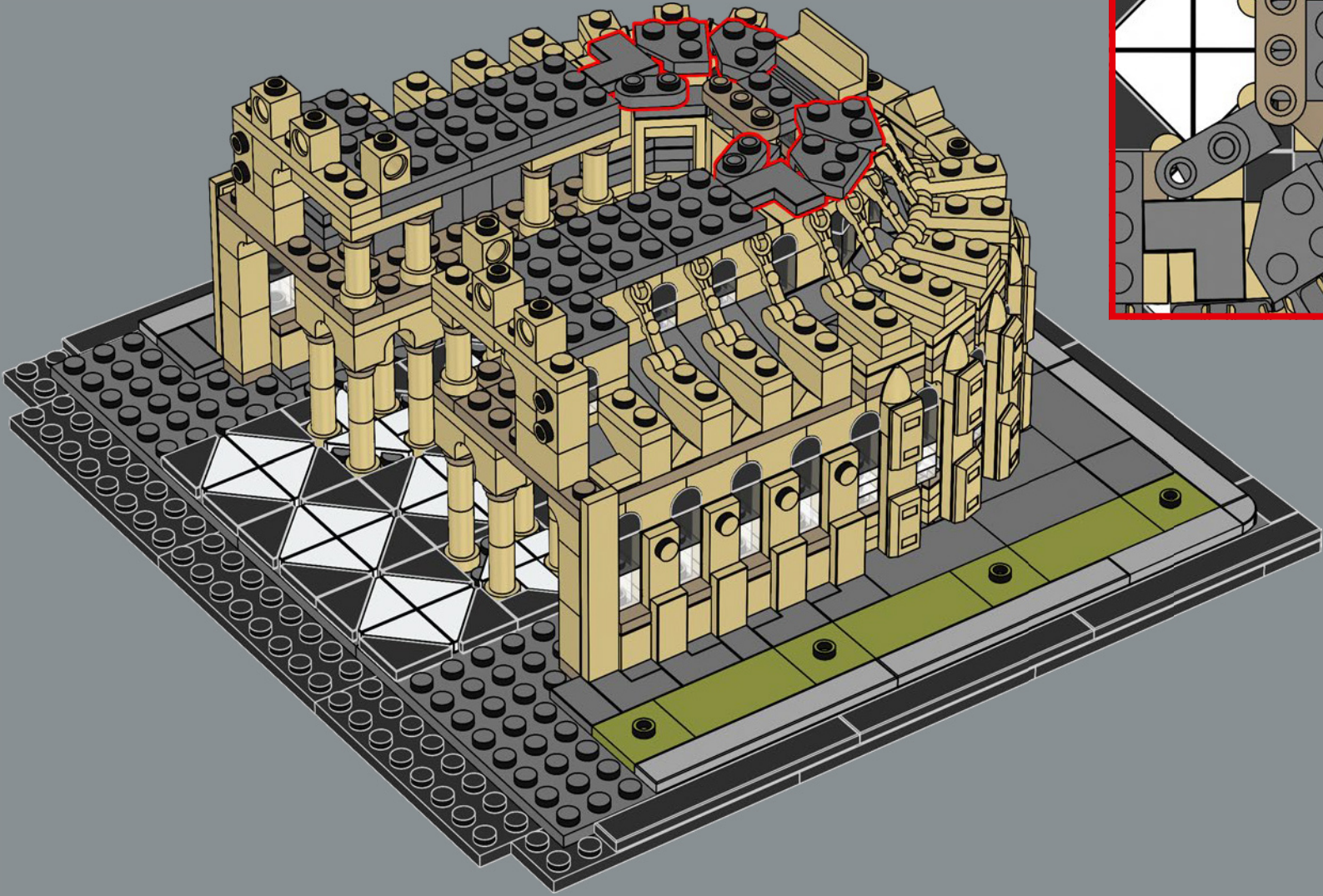

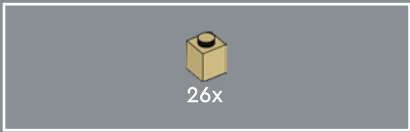

99

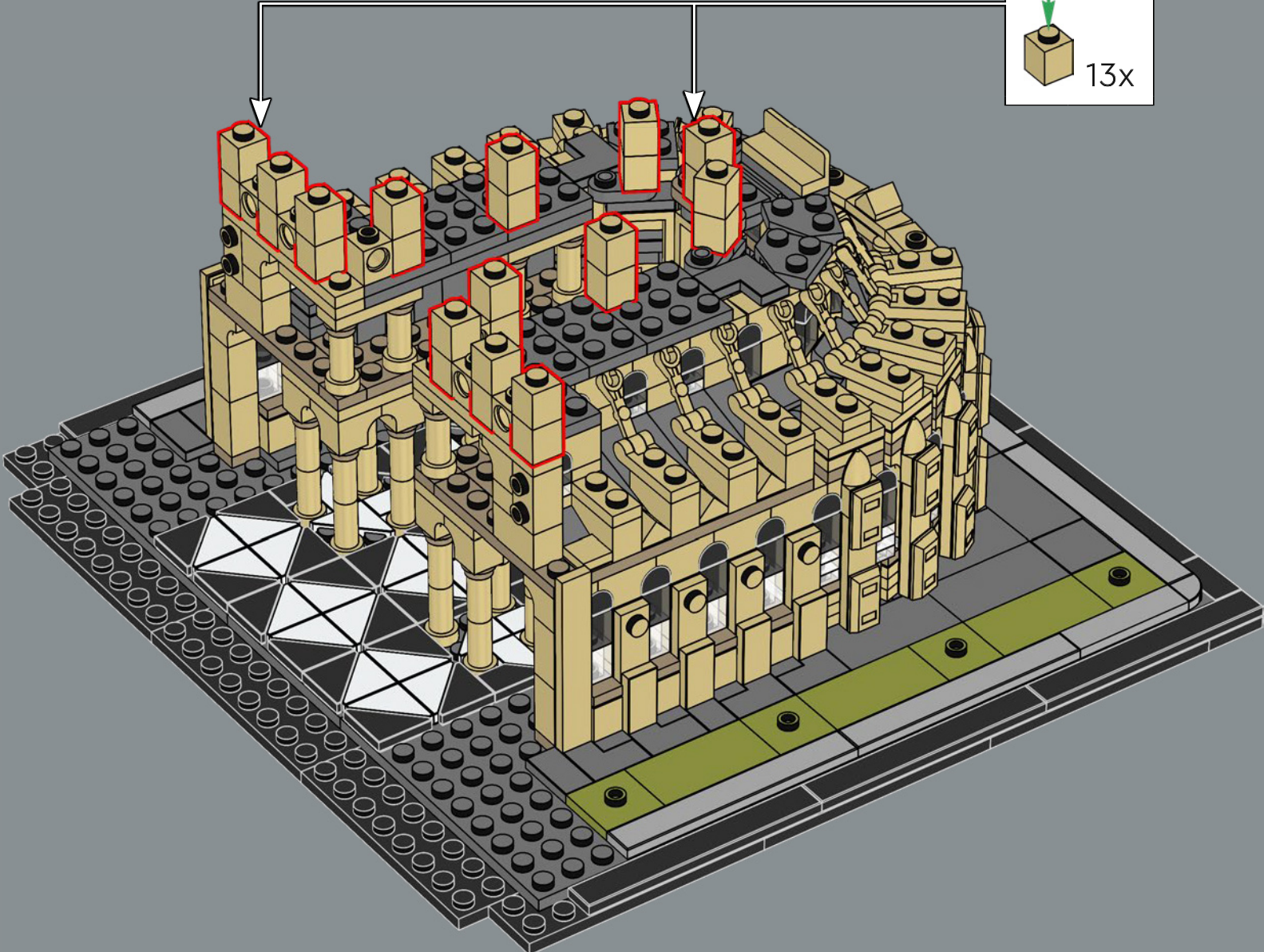
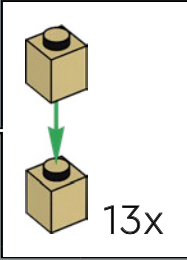

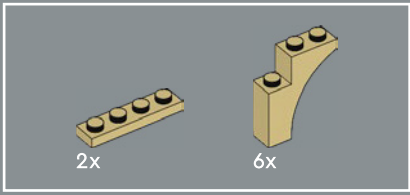

100

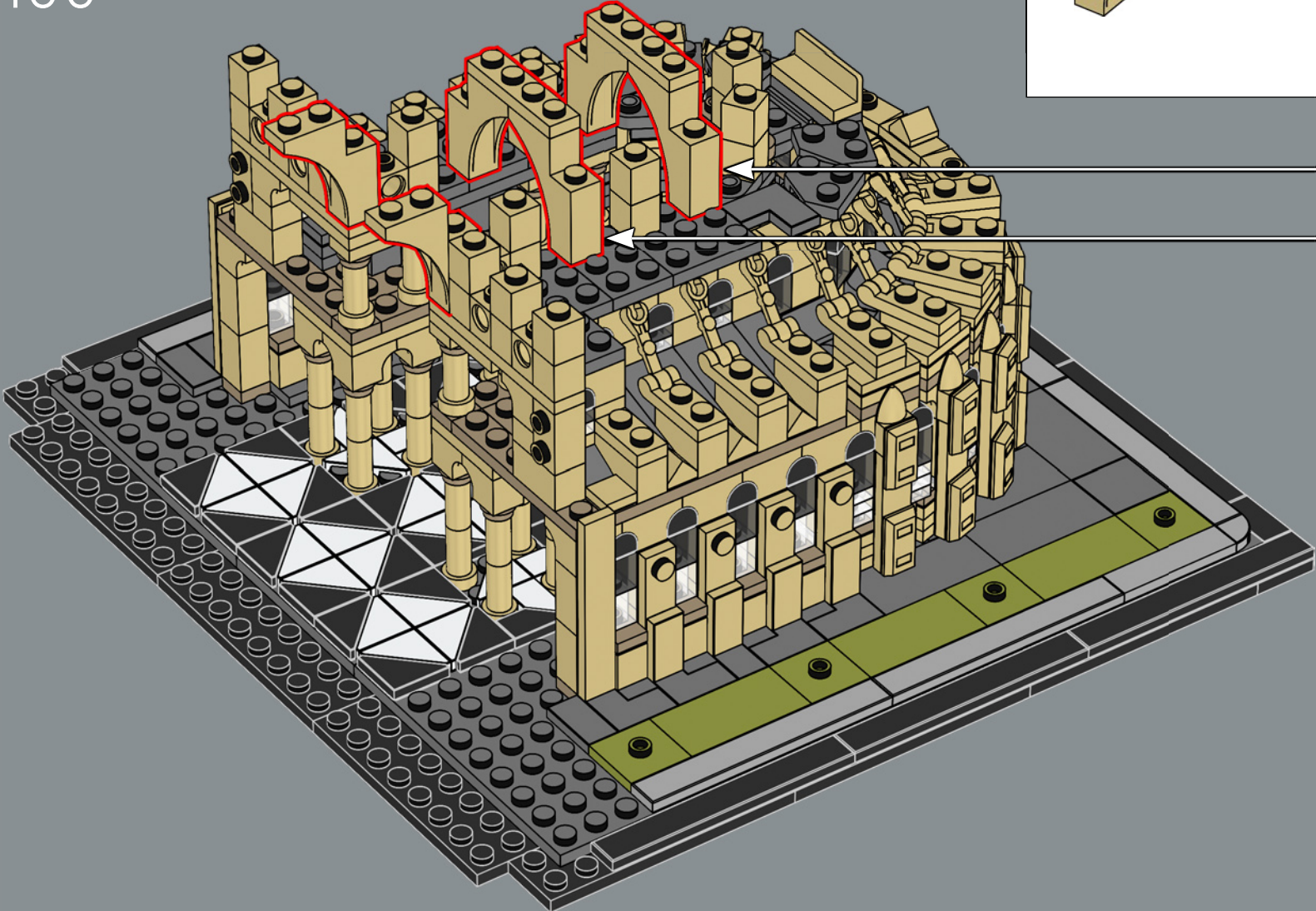
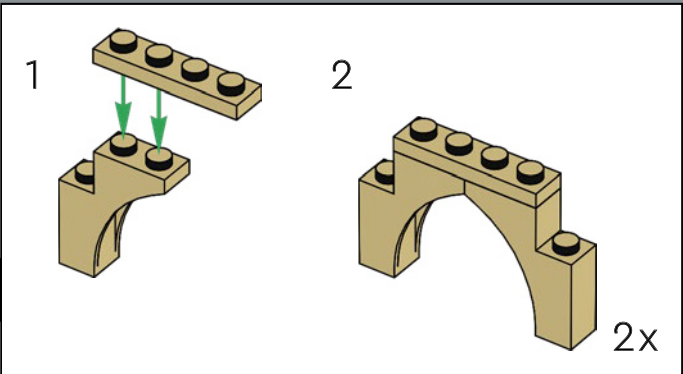





101

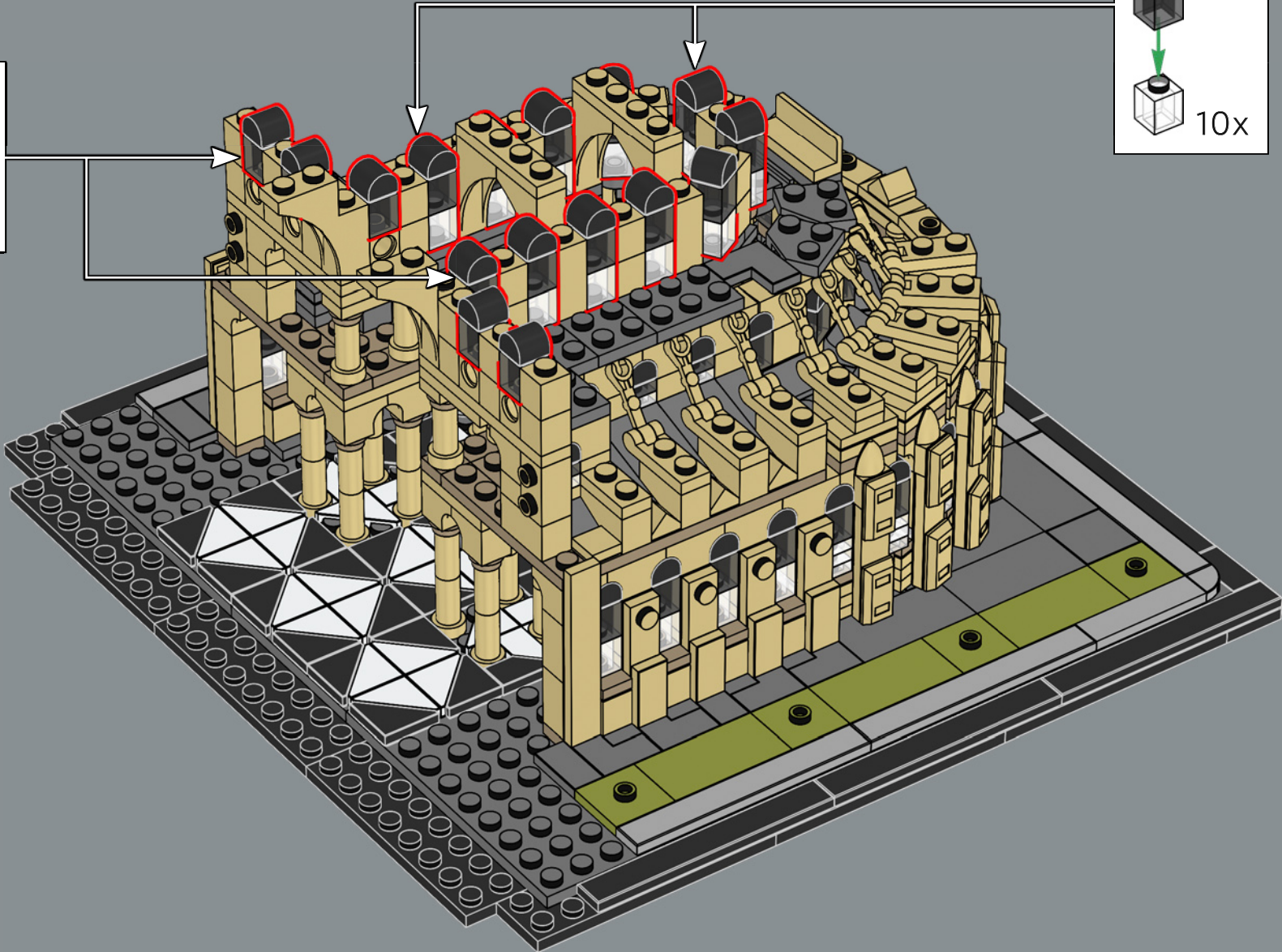
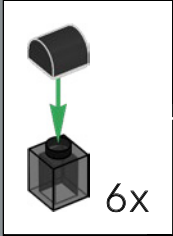

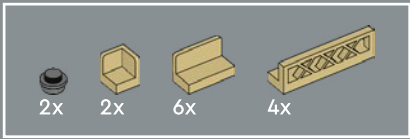

102

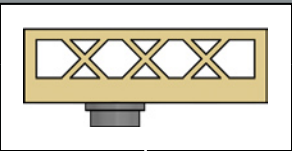
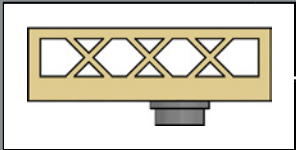
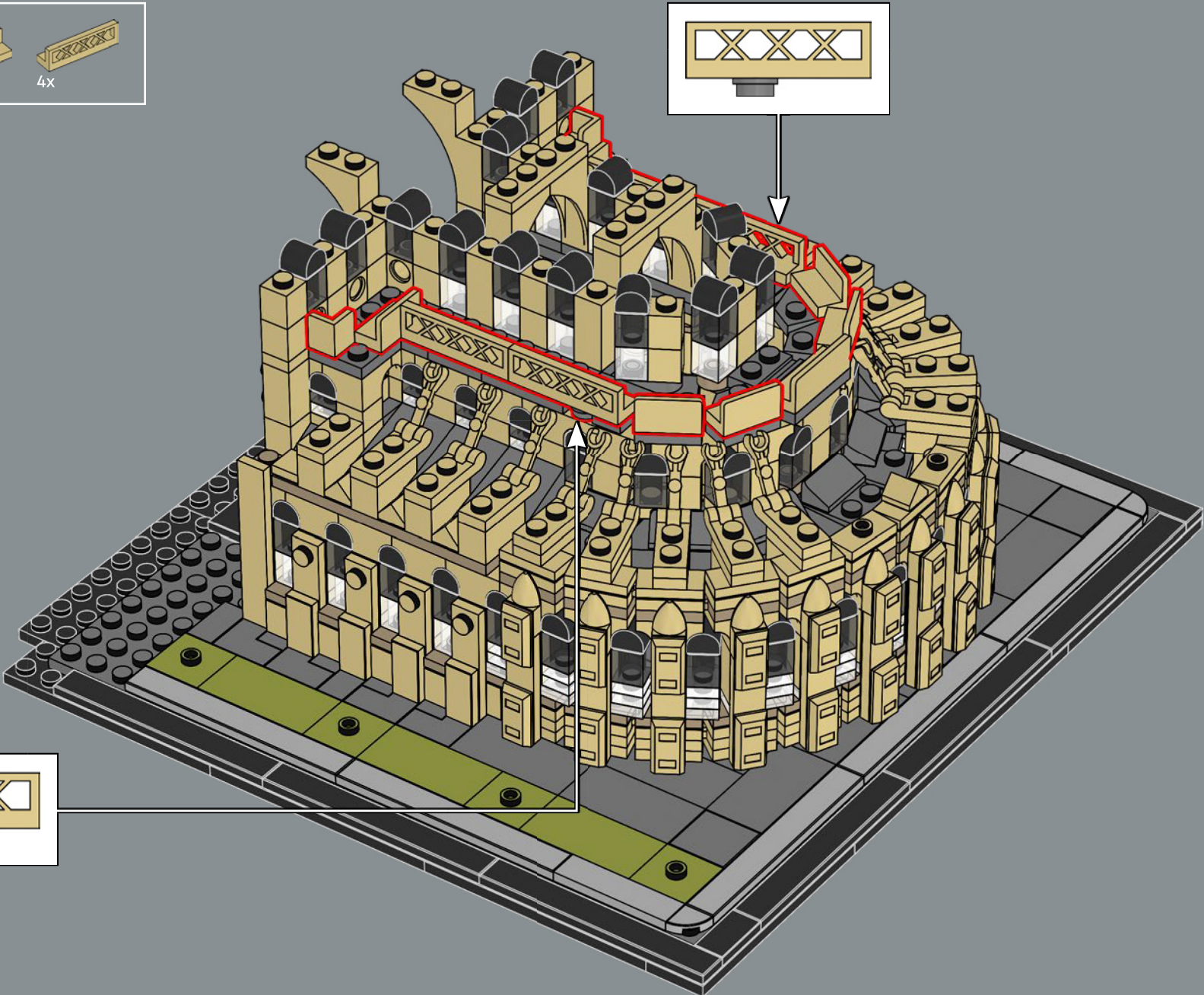

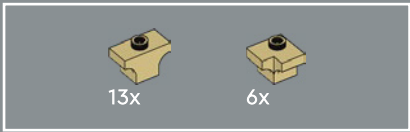

103

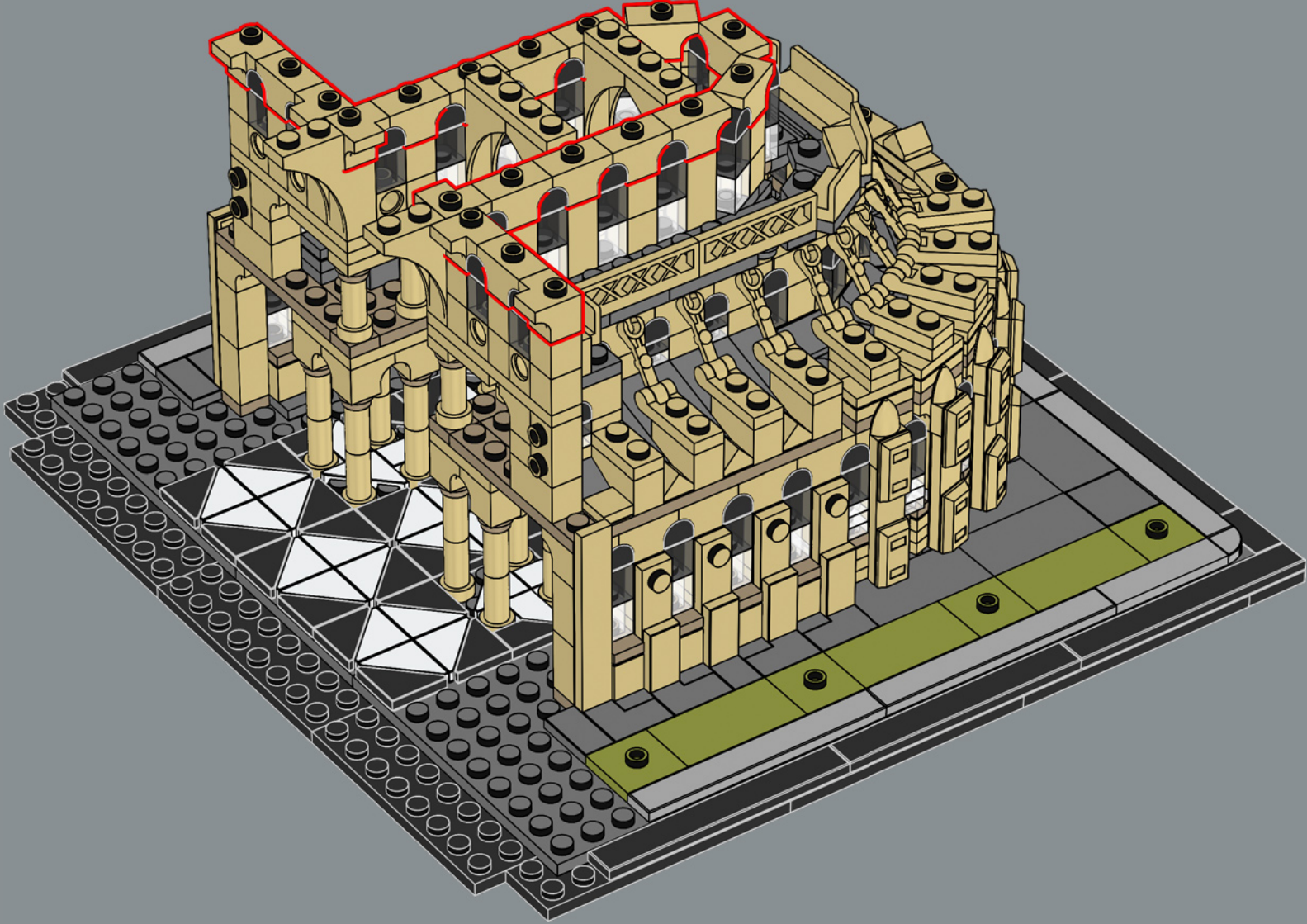

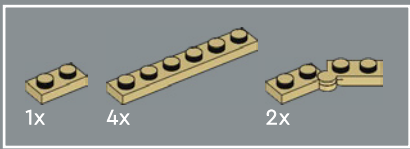

104

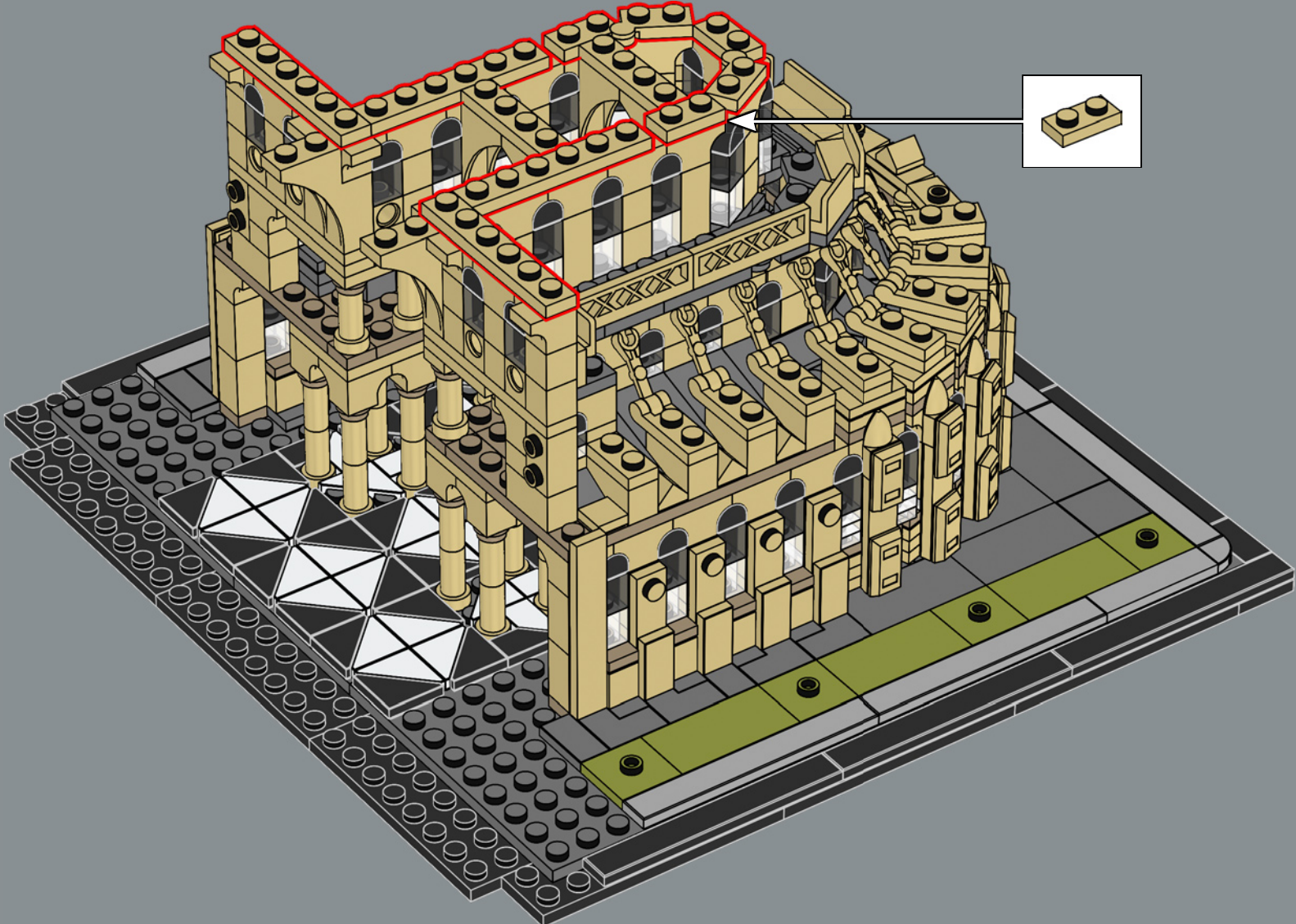

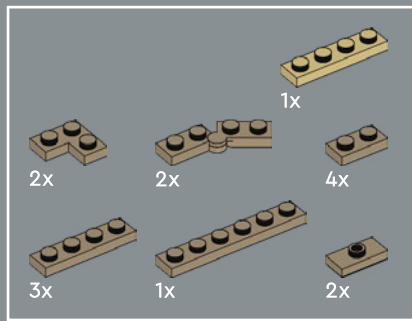

105

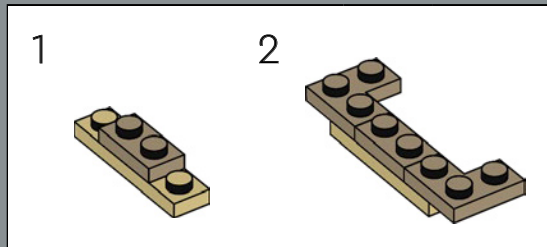
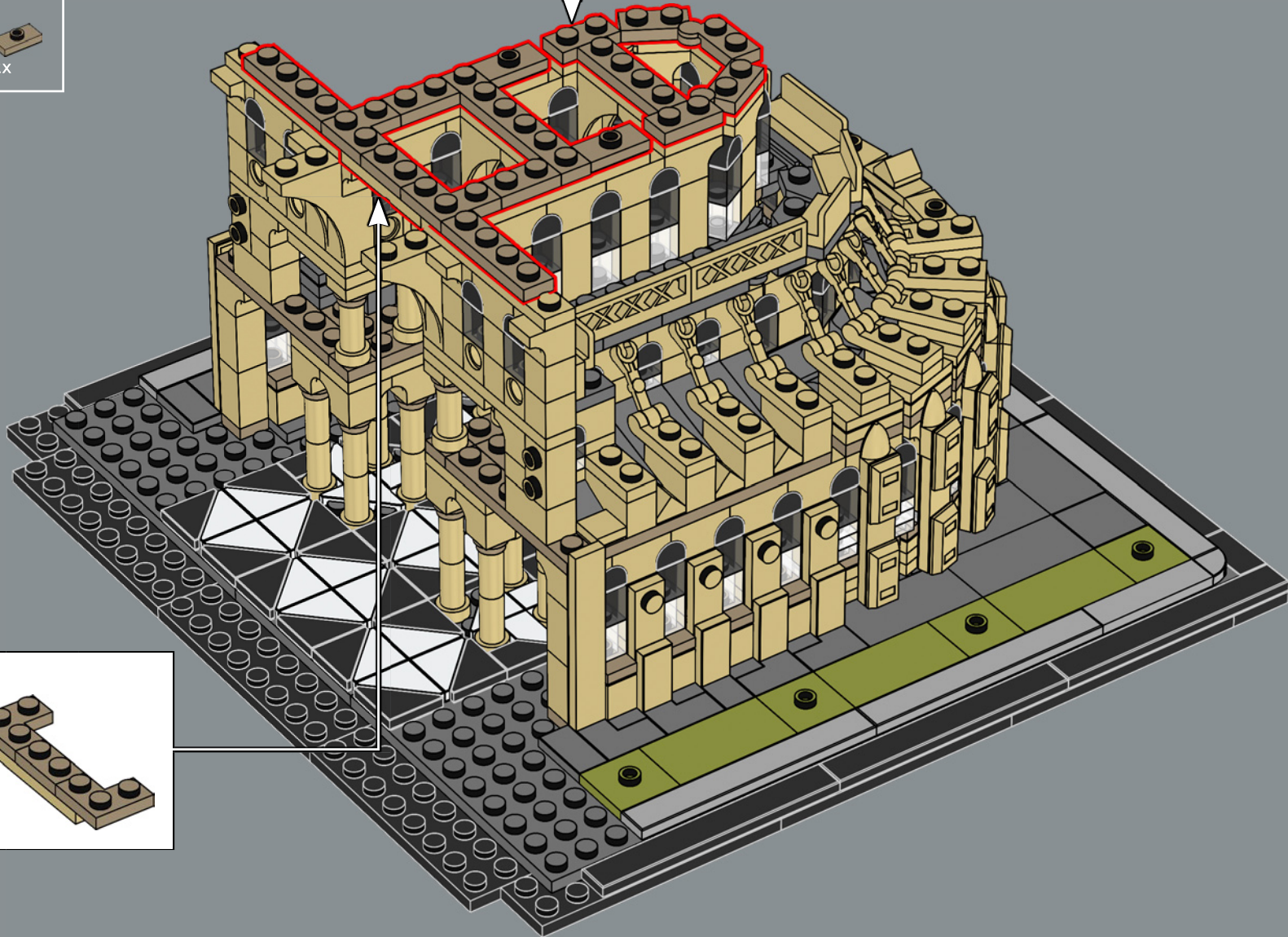
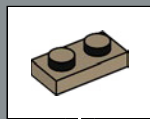

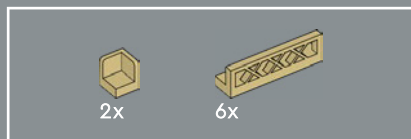

106

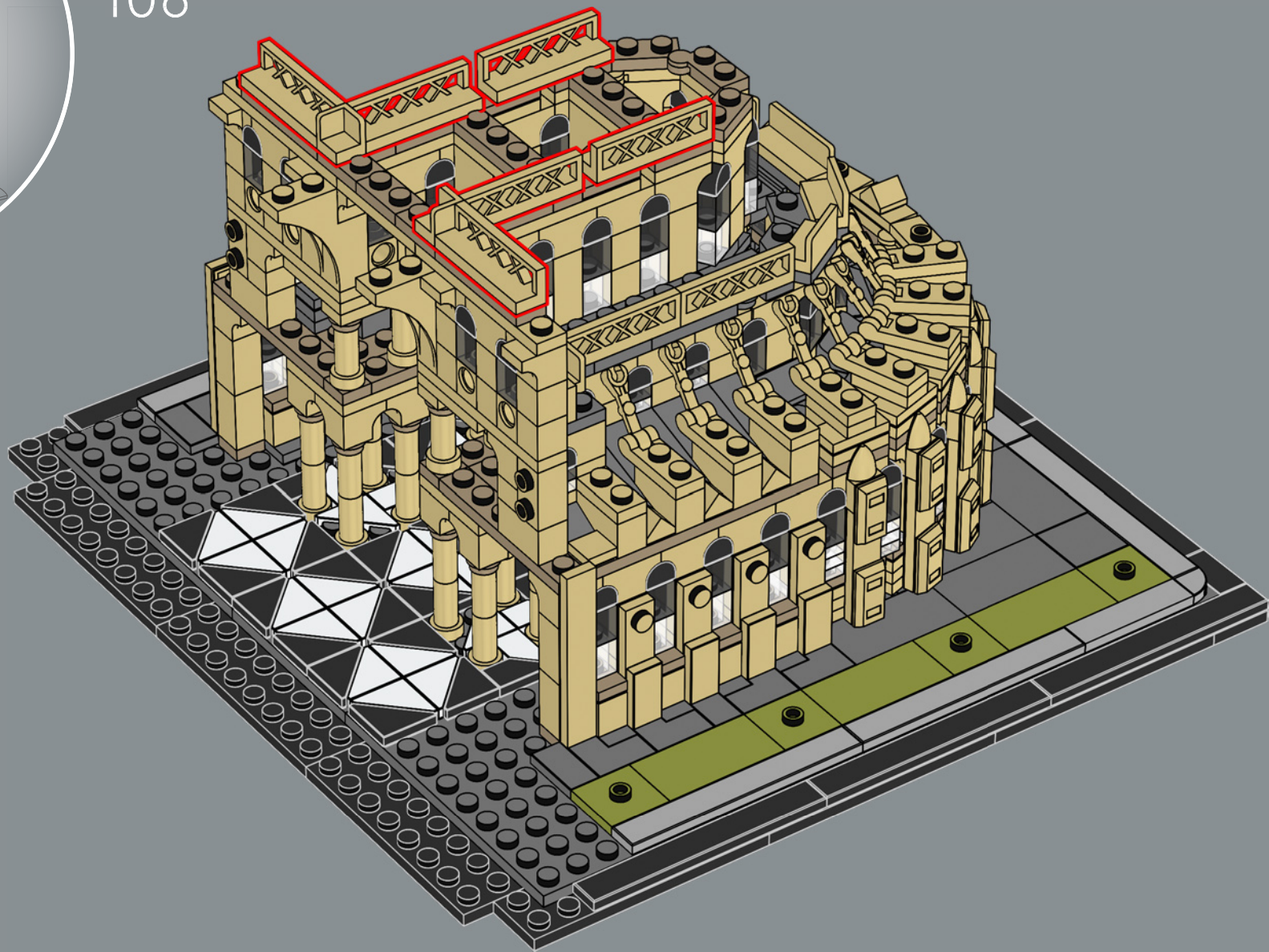

6x      10x

4x

6x

107

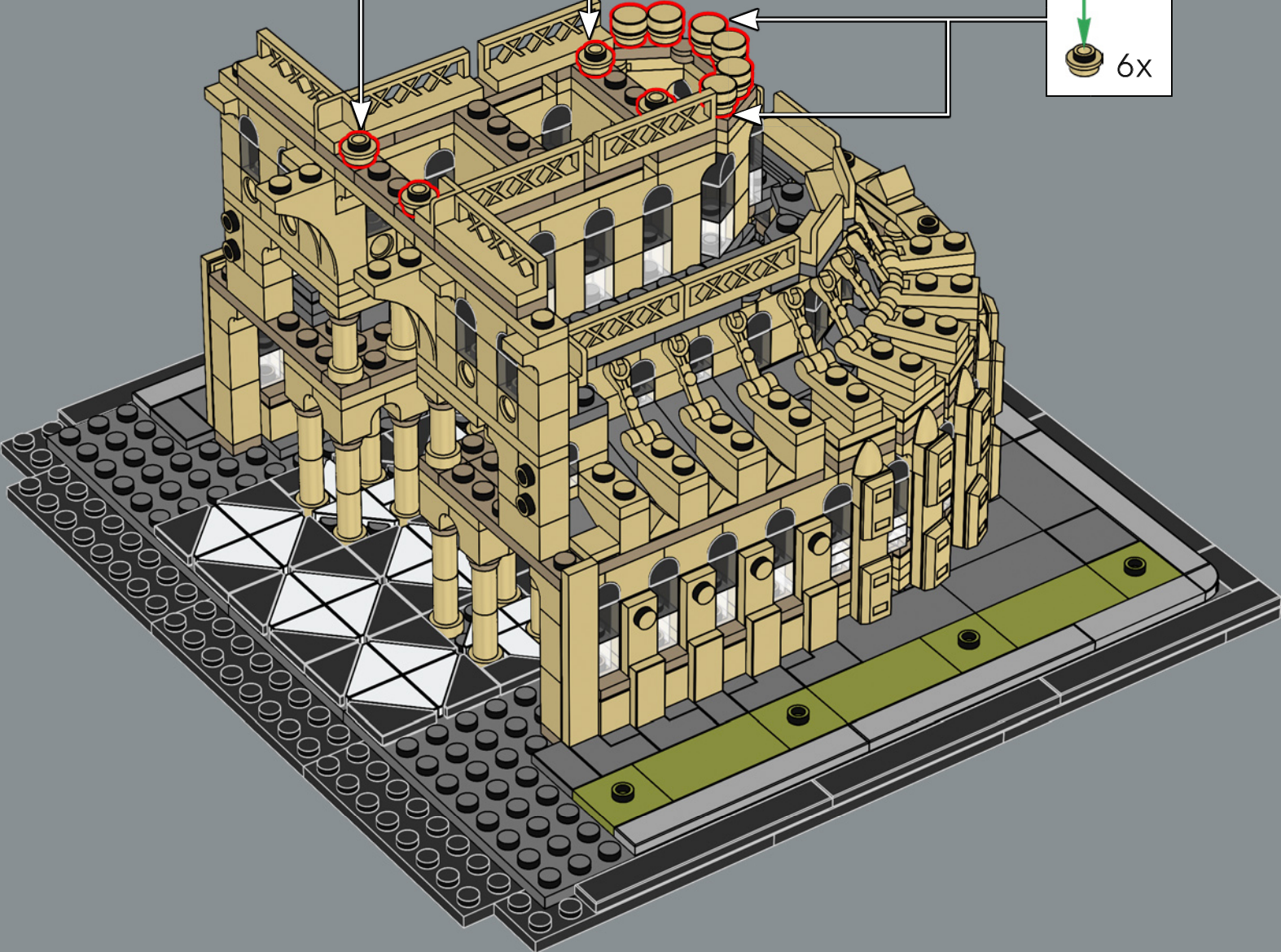

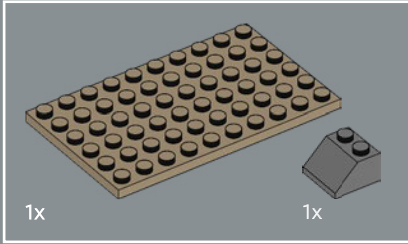
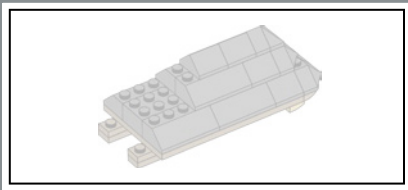

108

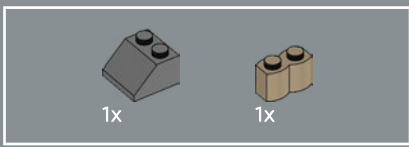
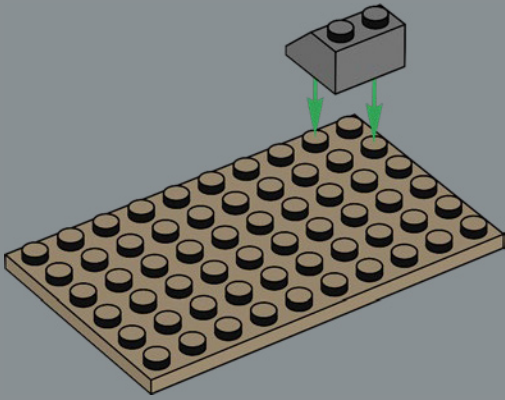

109

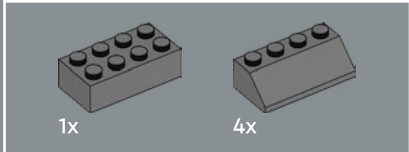
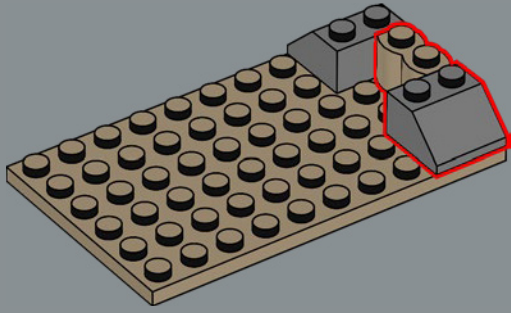

110

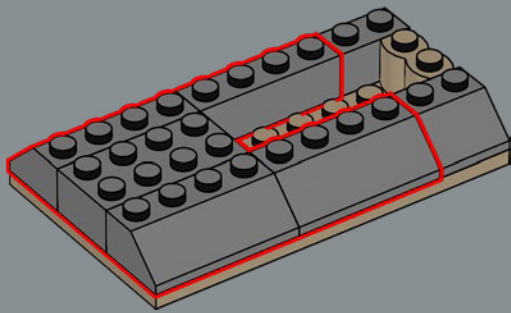



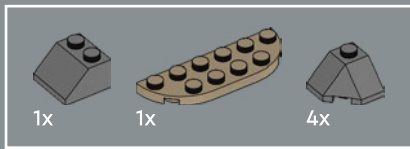

111

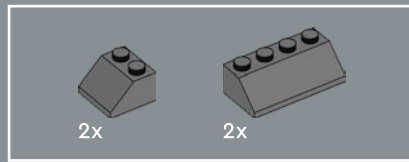
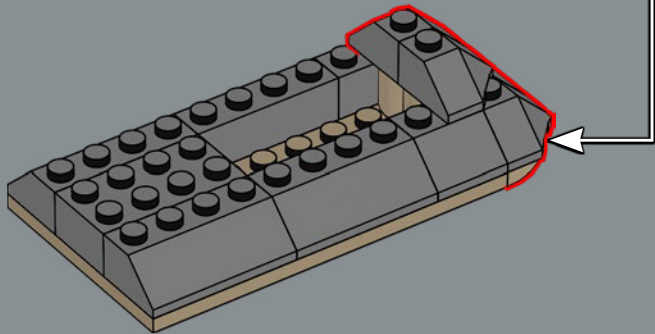

112

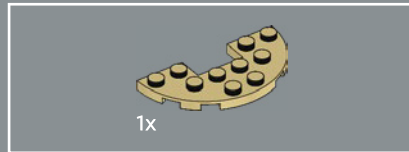
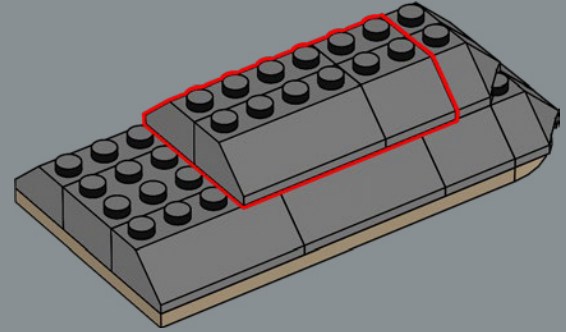

113

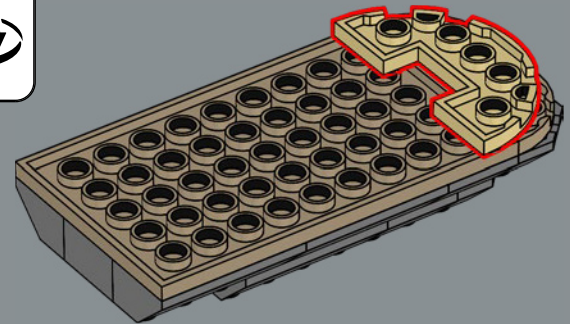

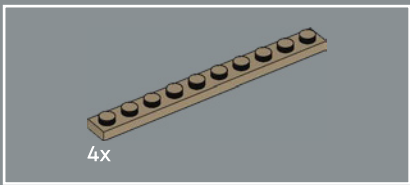

114

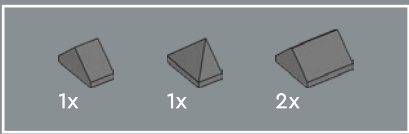
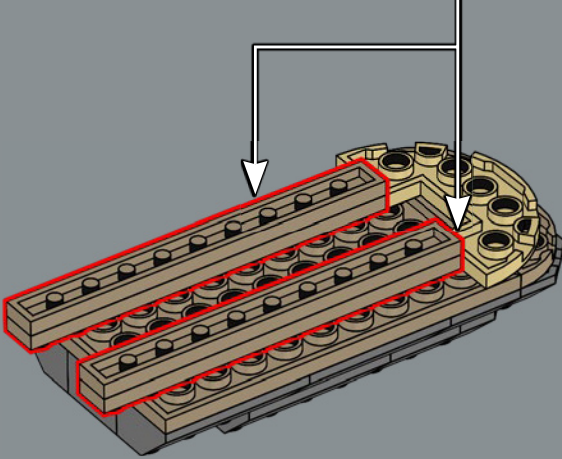
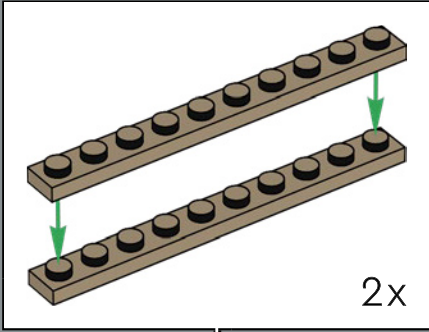

115

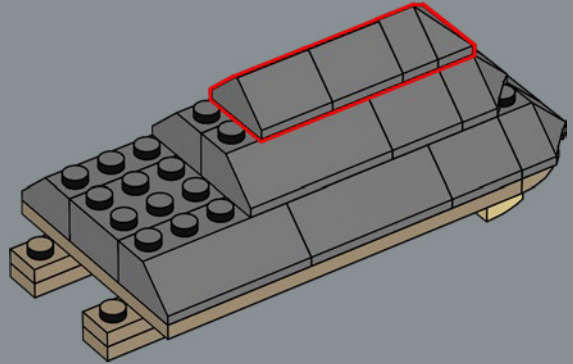

1177 - Il coro e l'abside sono quasi completati, ad eccezione delle volte alte. Il tetto e la struttura in legno vengono costruiti prima delle volte per proteggerle dagli elementi.

116

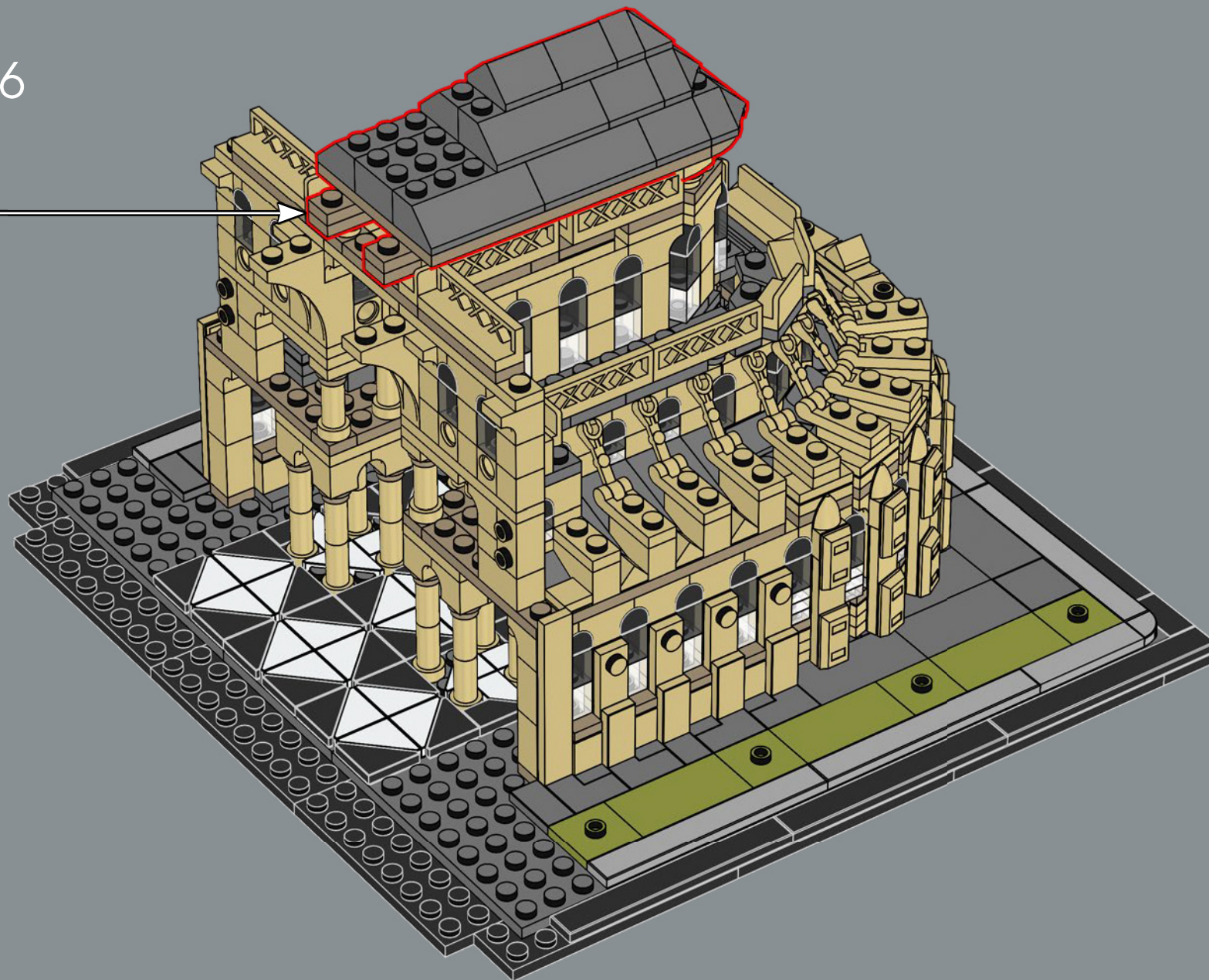

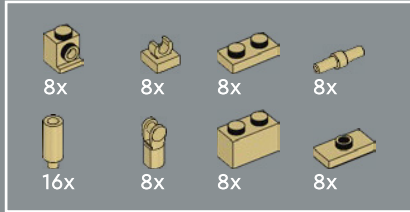
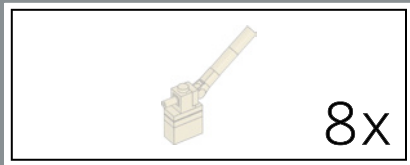

117

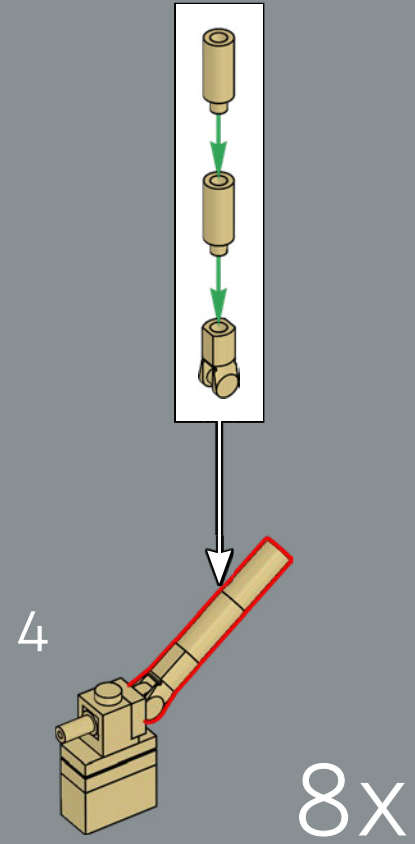
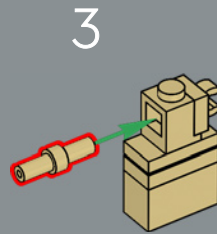
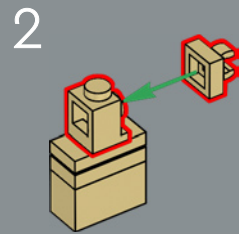
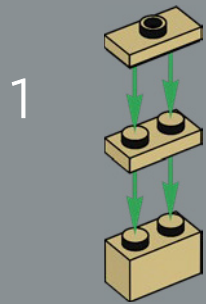

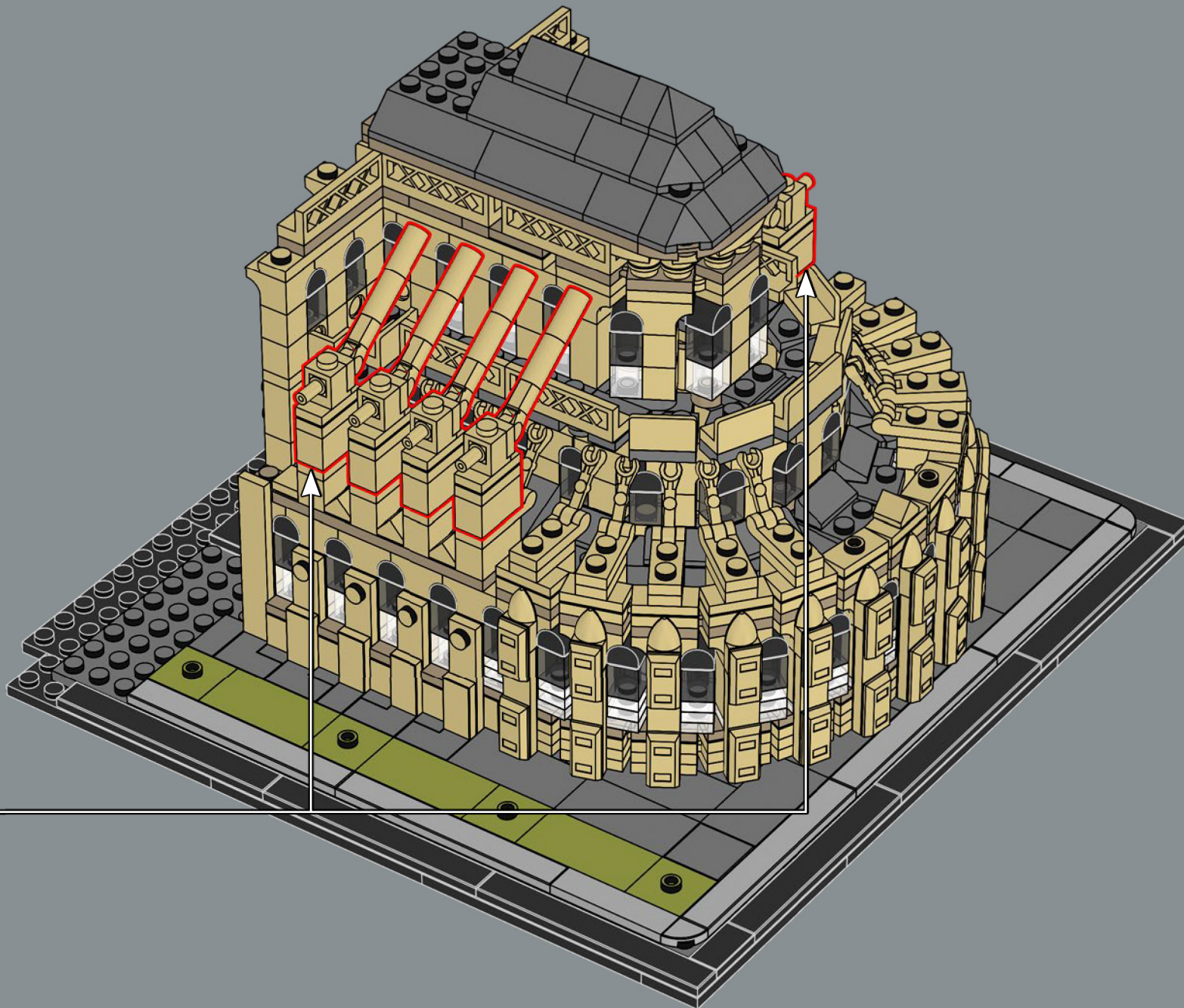

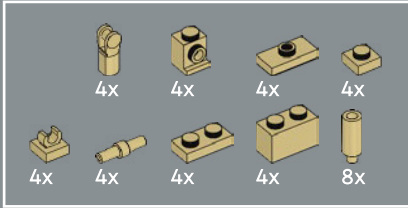
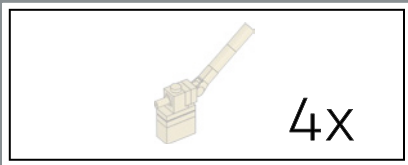

118

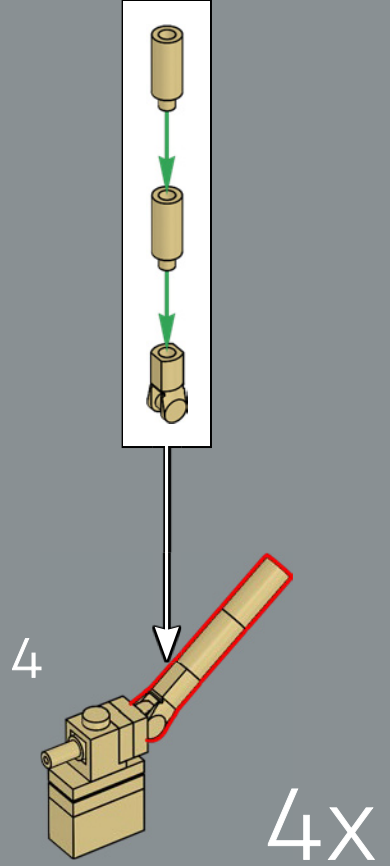
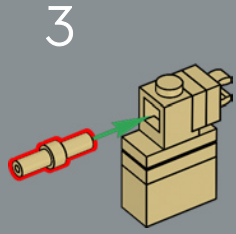
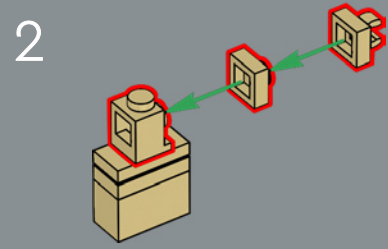
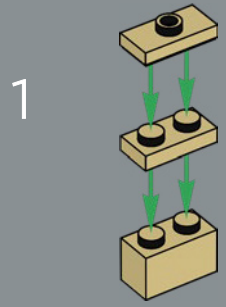

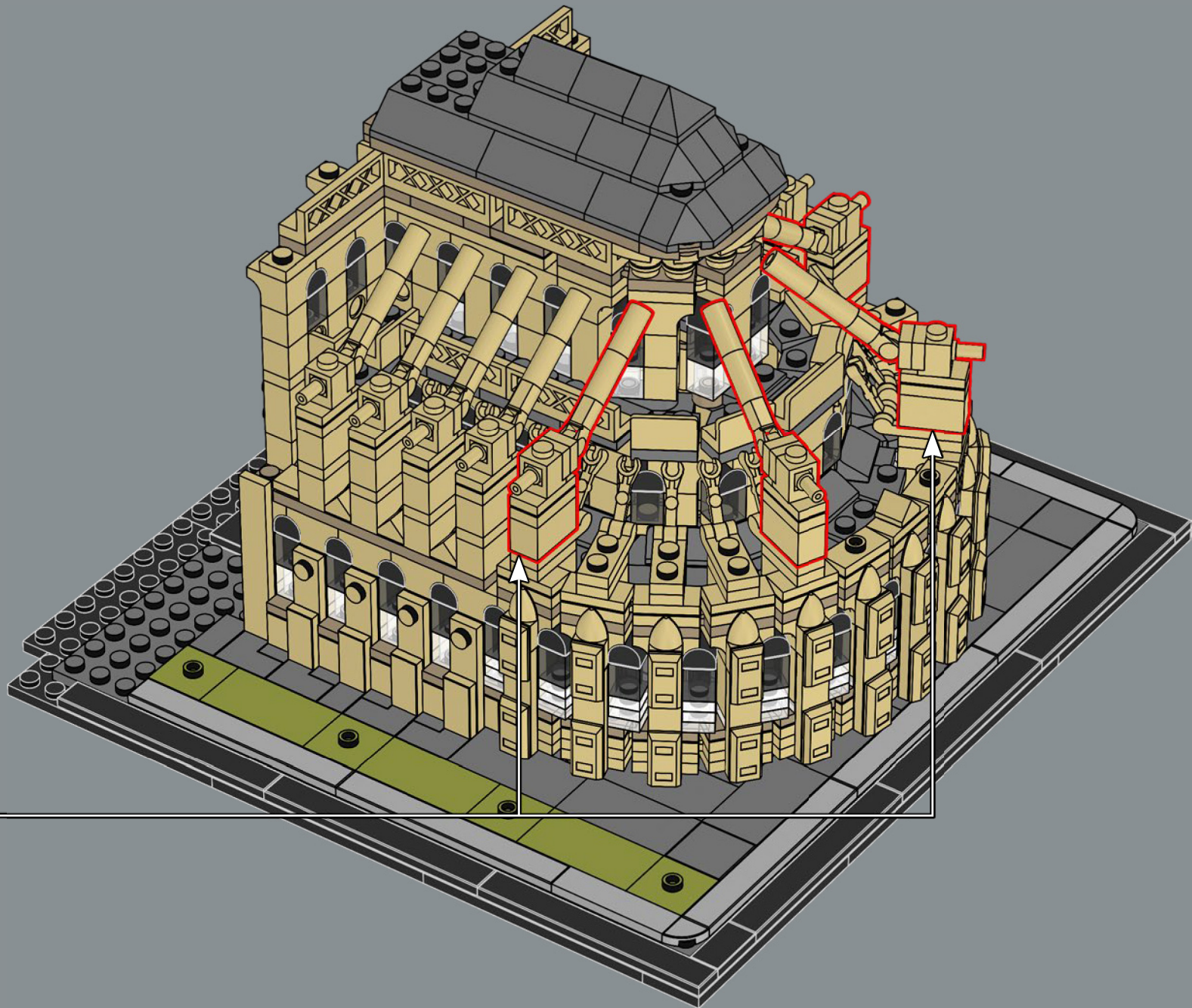

La cattedrale di Notre-Dame è la prima a integrare completamente archi rampanti, tratti distintivi dell'architettura gotica.

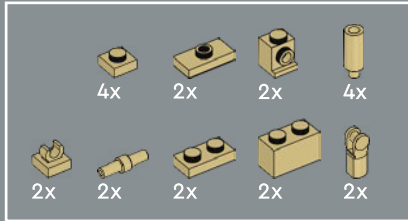
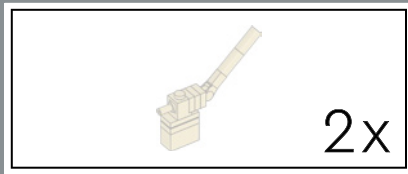

119

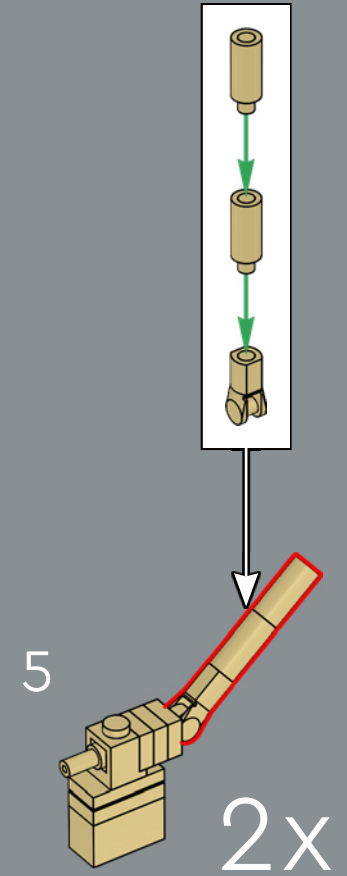
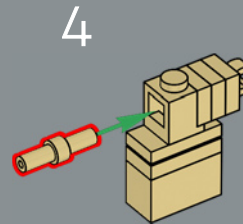
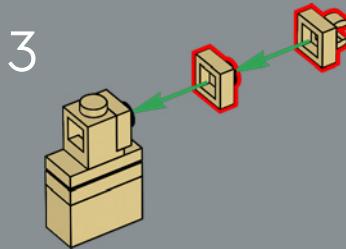
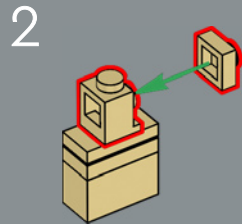
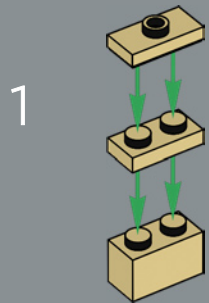



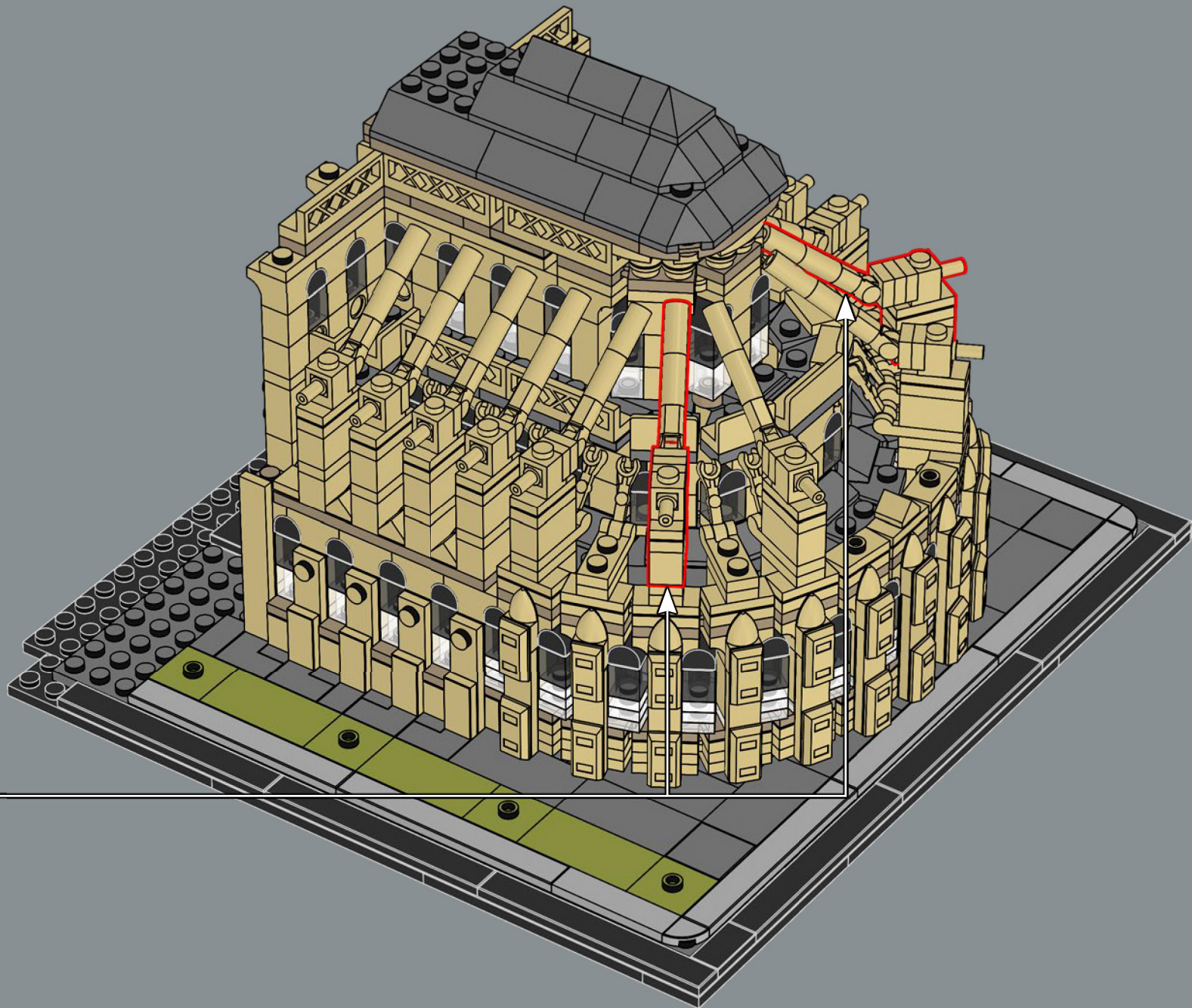

# UN FAMOSO EDIFICIO LEGO® PRENDE FORMA

1182-1200



*Proseguono i lavori di costruzione nel transetto e  
nelle campate del lato sud della navata.*

✂ Lunga 128 m, larga 48 m e alta 69 m, la cattedrale di Notre-Dame fu costruita sul sito di una cattedrale esistente sull'île de la Cité nella Senna. Mentre la prima parte orientale completata fungeva da chiesa provvisoria, i lavori di costruzione si concentrarono sul transetto e sulle prime campate sul lato sud della navata. Dall'originario stile architettonico romanico, la costruzione incorporò gradualmente stili architettonici contemporanei, evolvendo nello stile gotico di oggi. Questo modello rimane fedele alla costruzione sia della struttura interna sia dei dettagli architettonici esterni - con alcune caratteristiche ridimensionate - per ricreare il maestoso spettacolo che ha meravigliato i visitatori nel corso dei secoli.

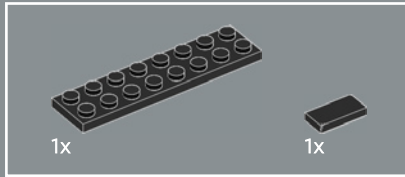
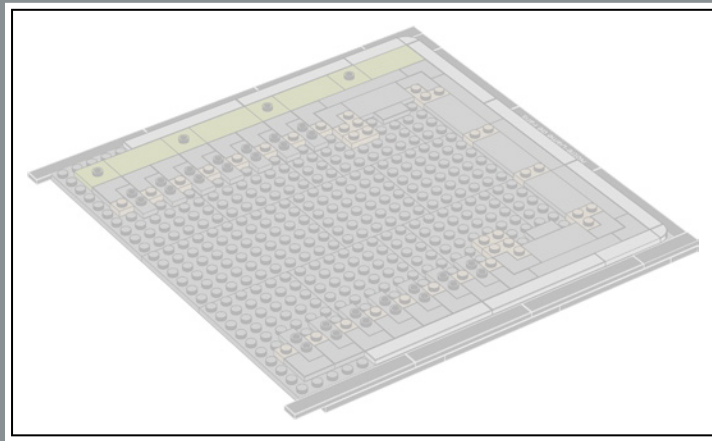

120

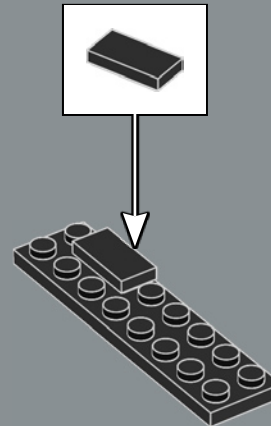

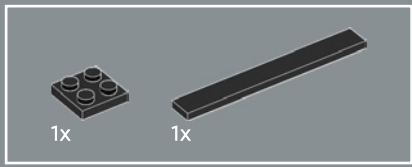

121

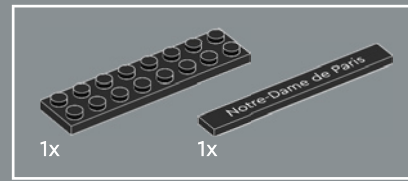
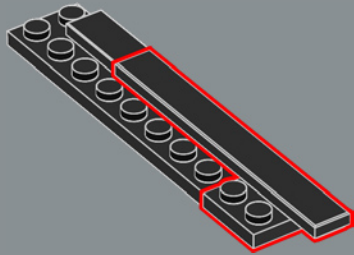

122

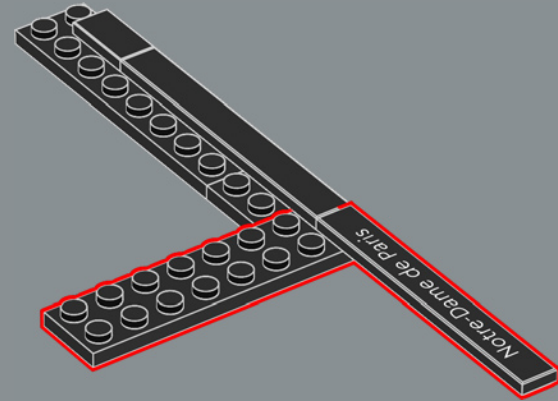

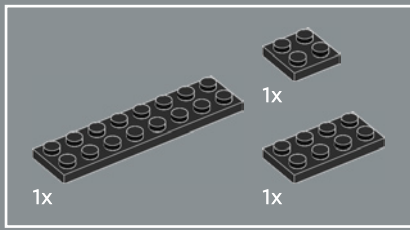

123

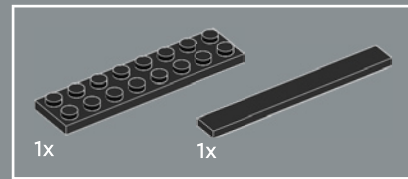
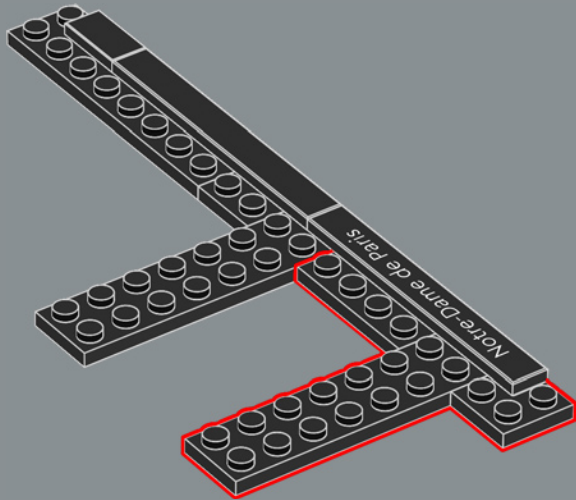

124

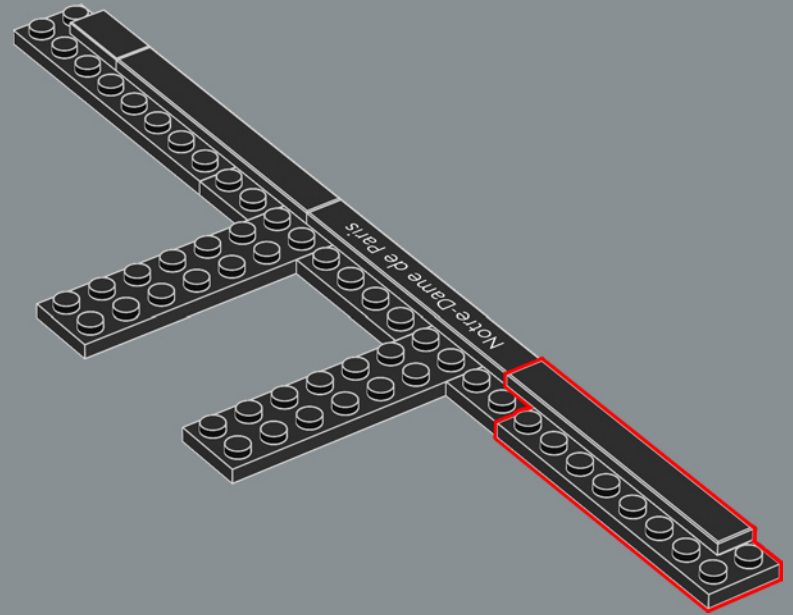

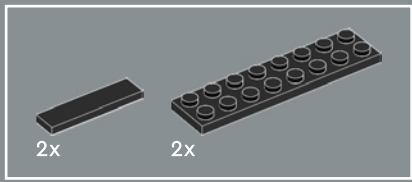

125

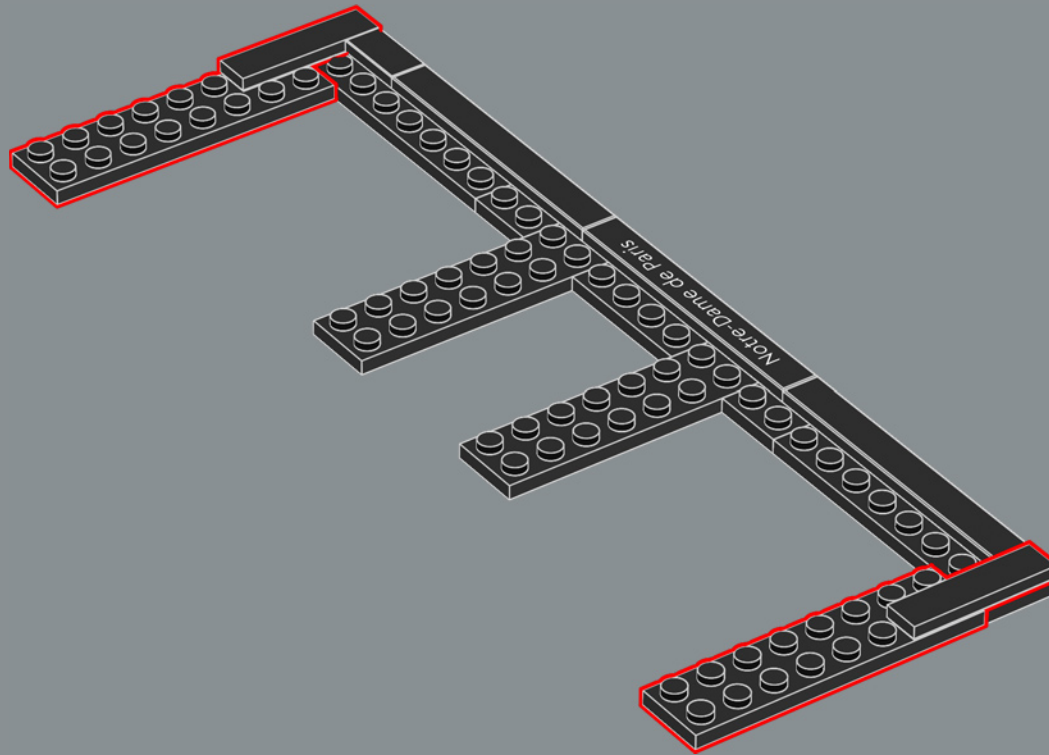

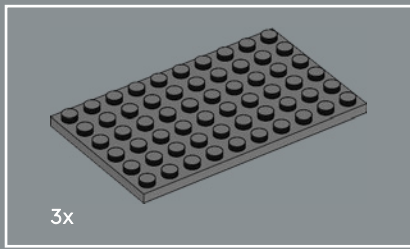

126

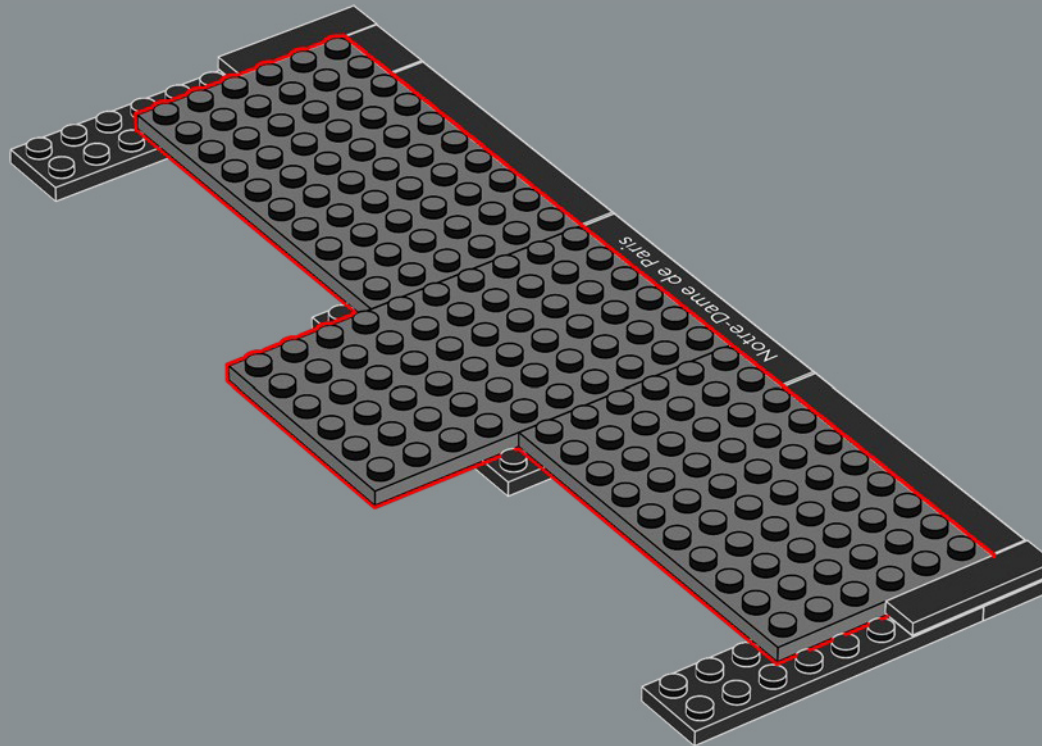

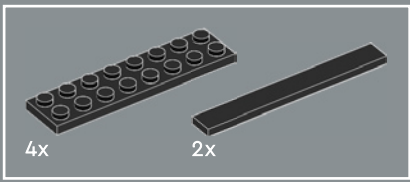

127

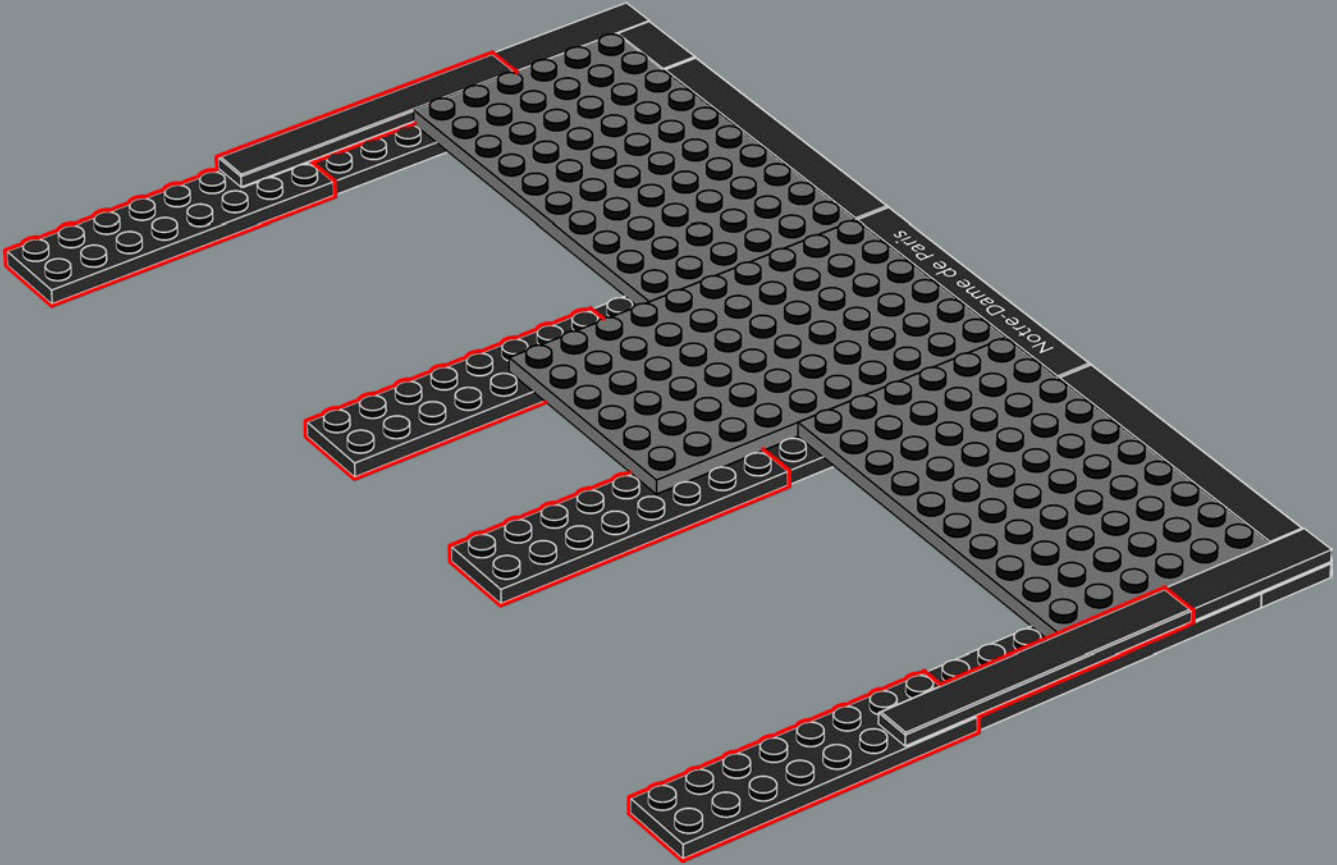



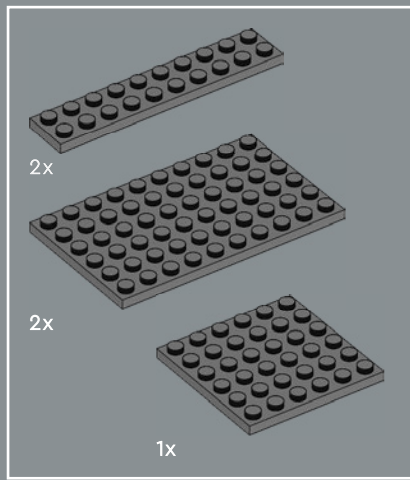

128

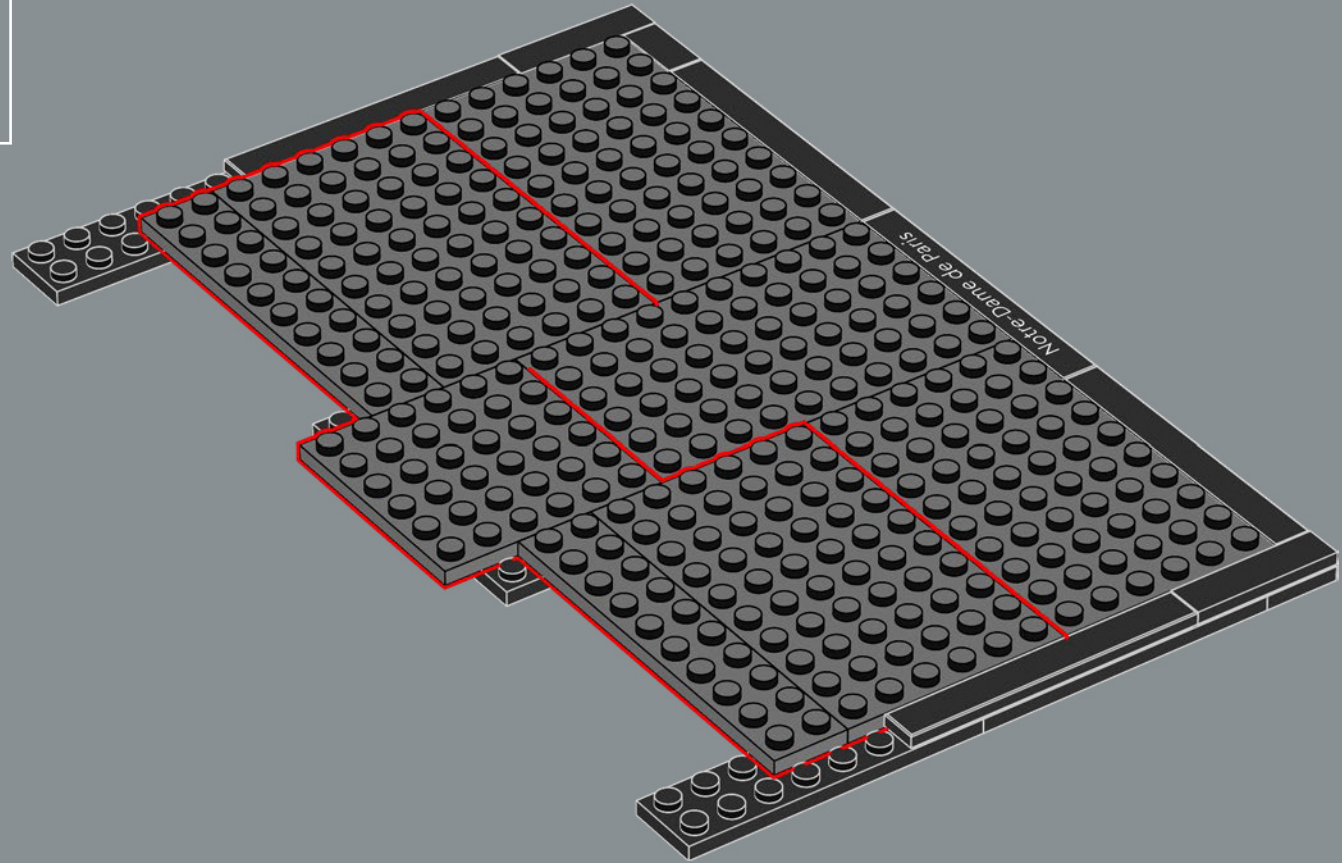

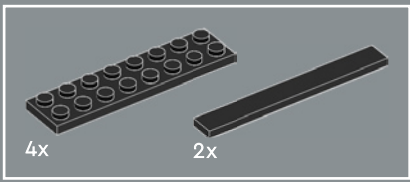

129

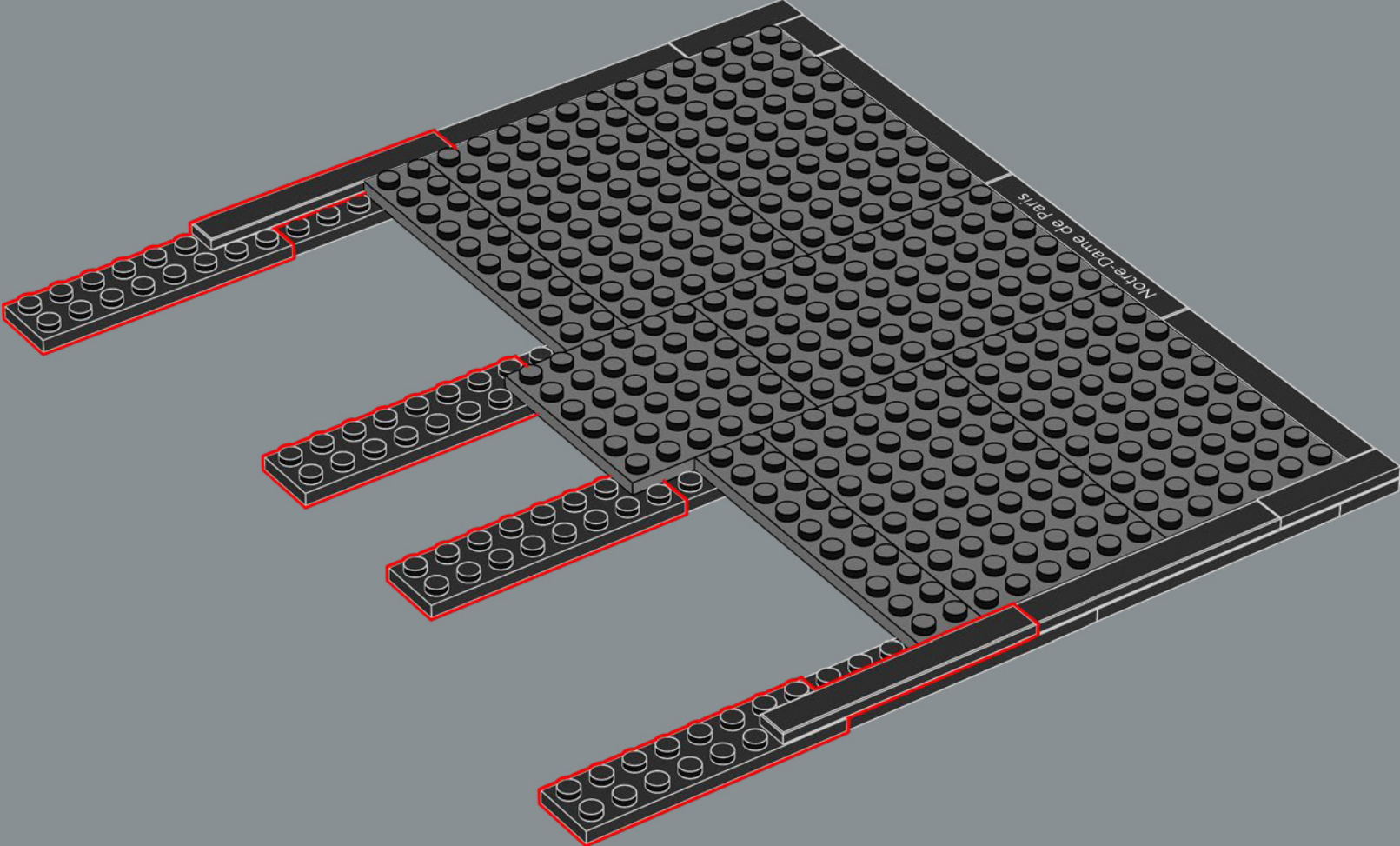

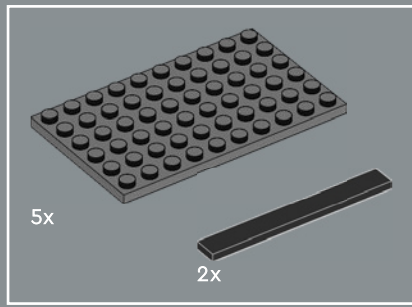

130

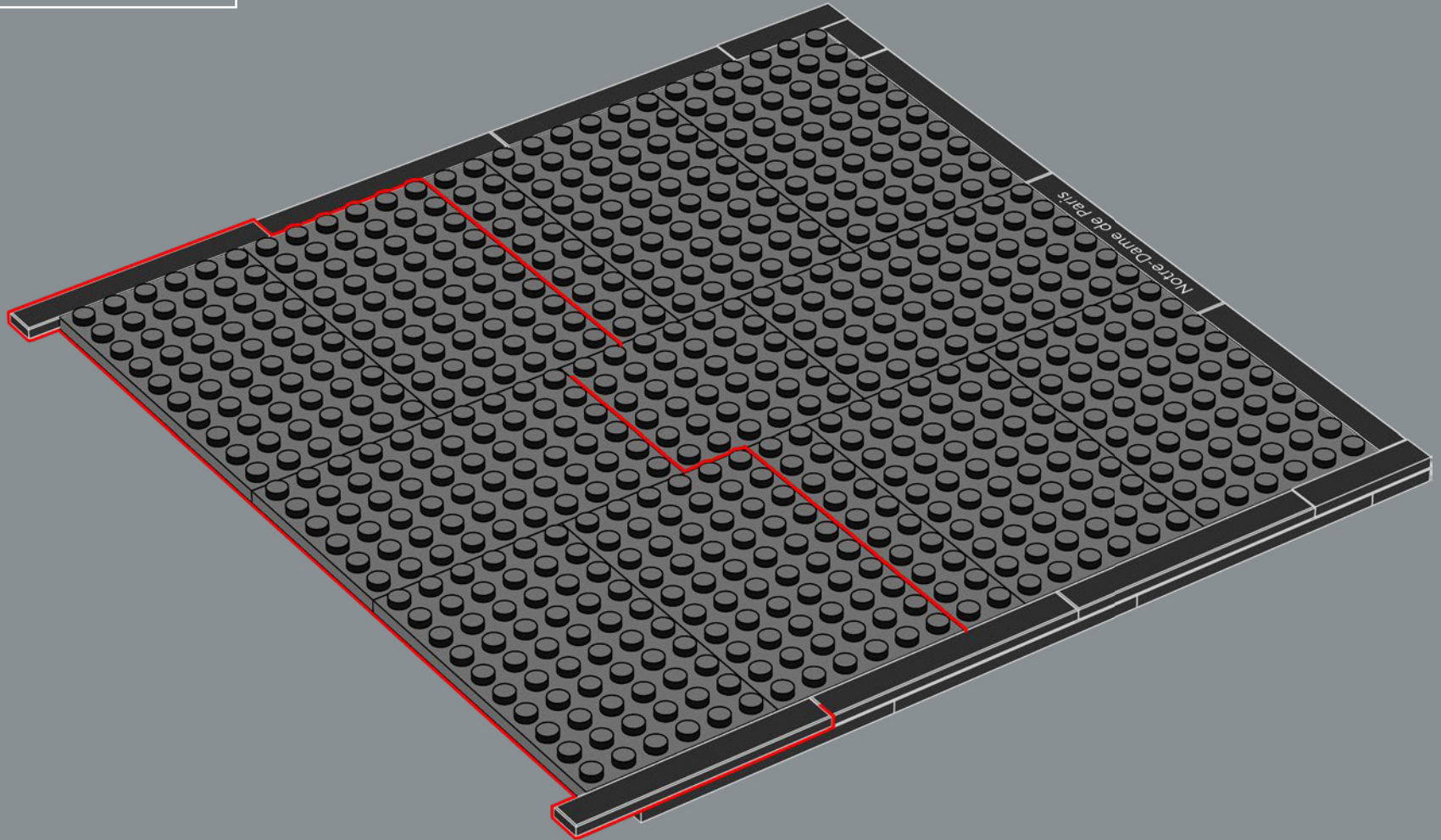

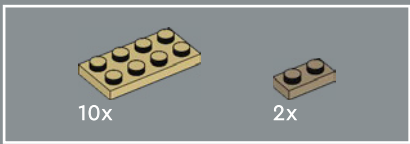

131

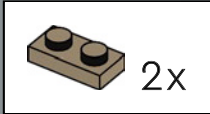
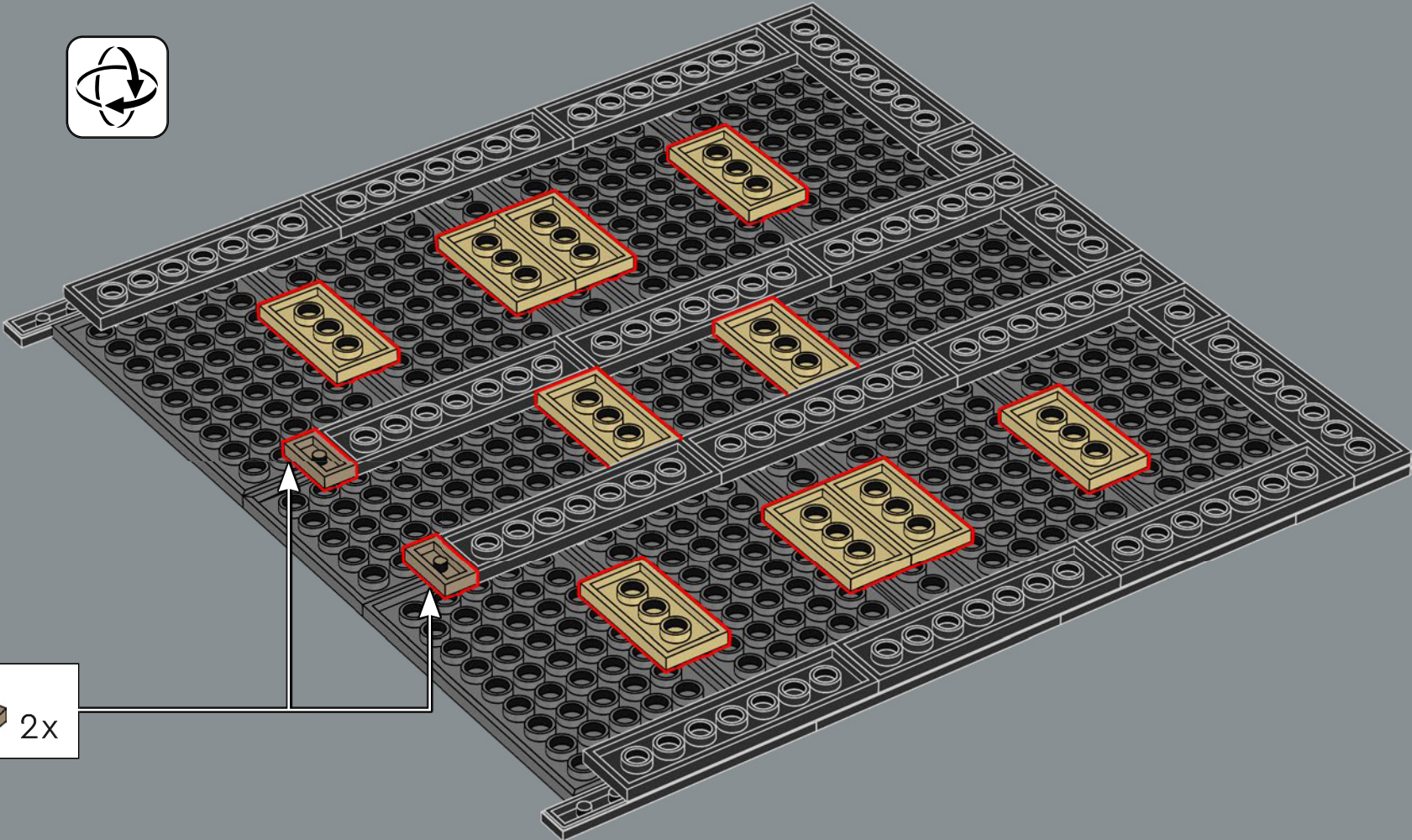

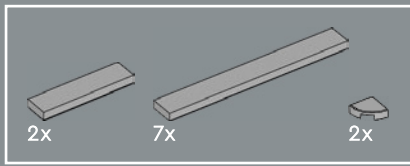

132

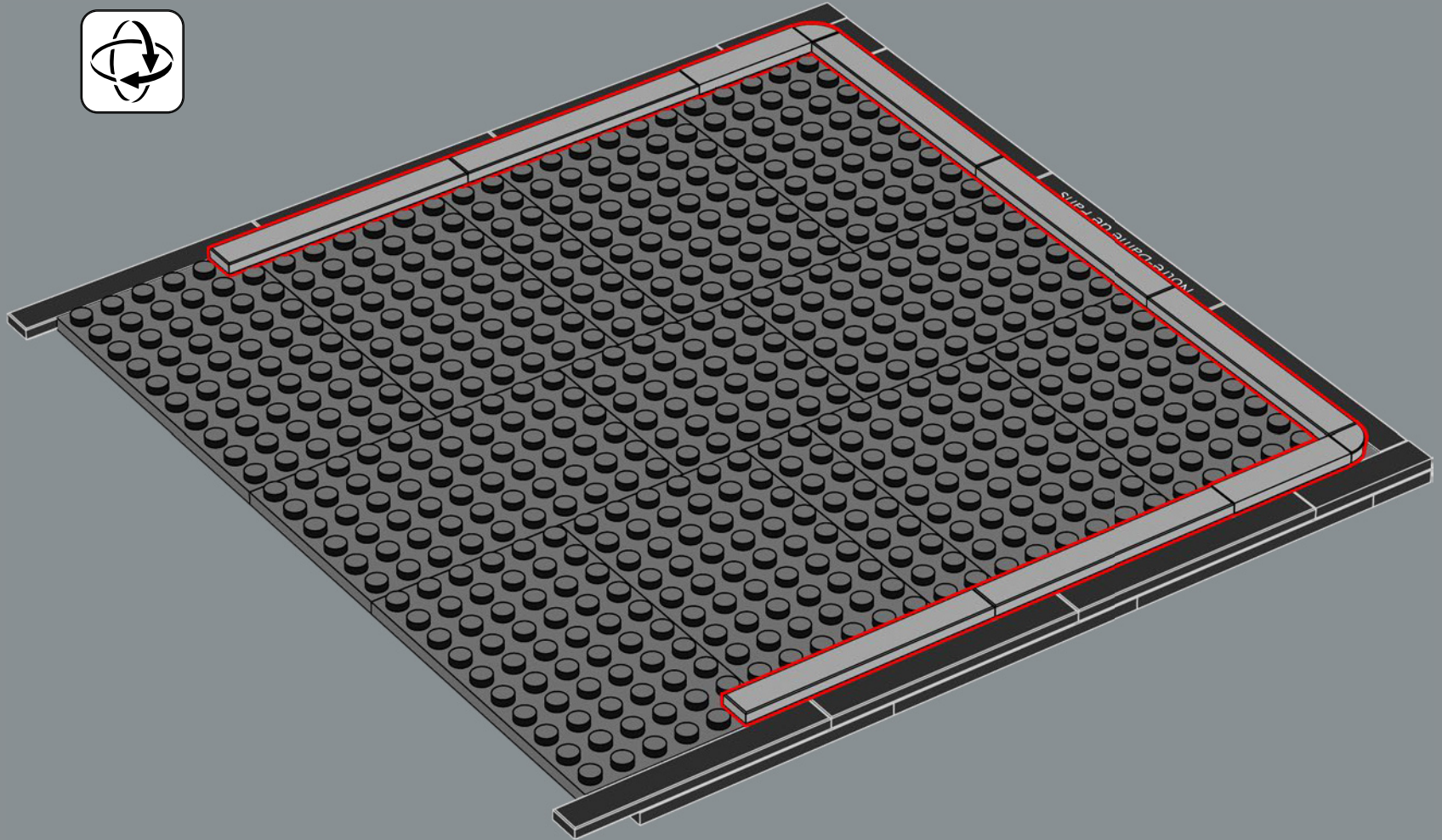

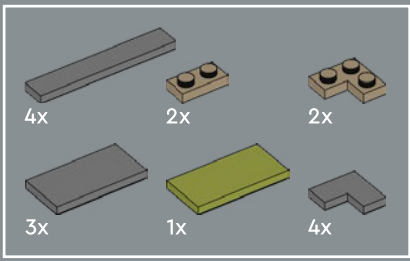

133

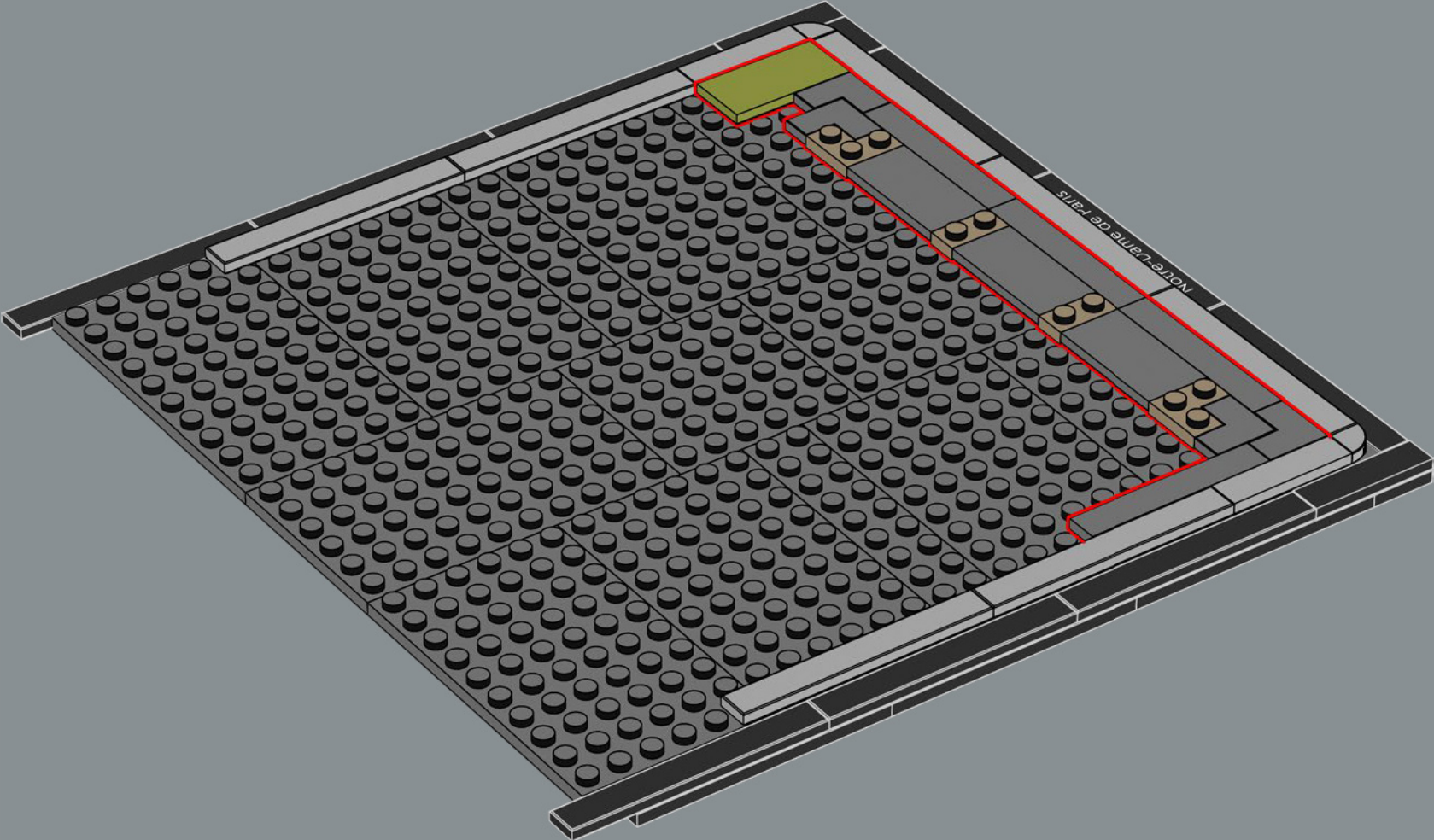

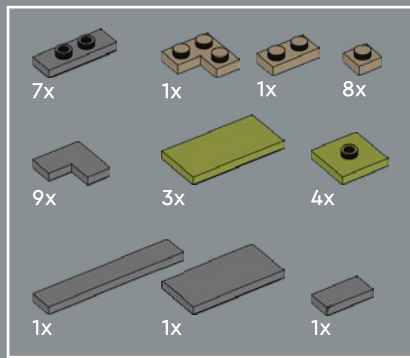

134

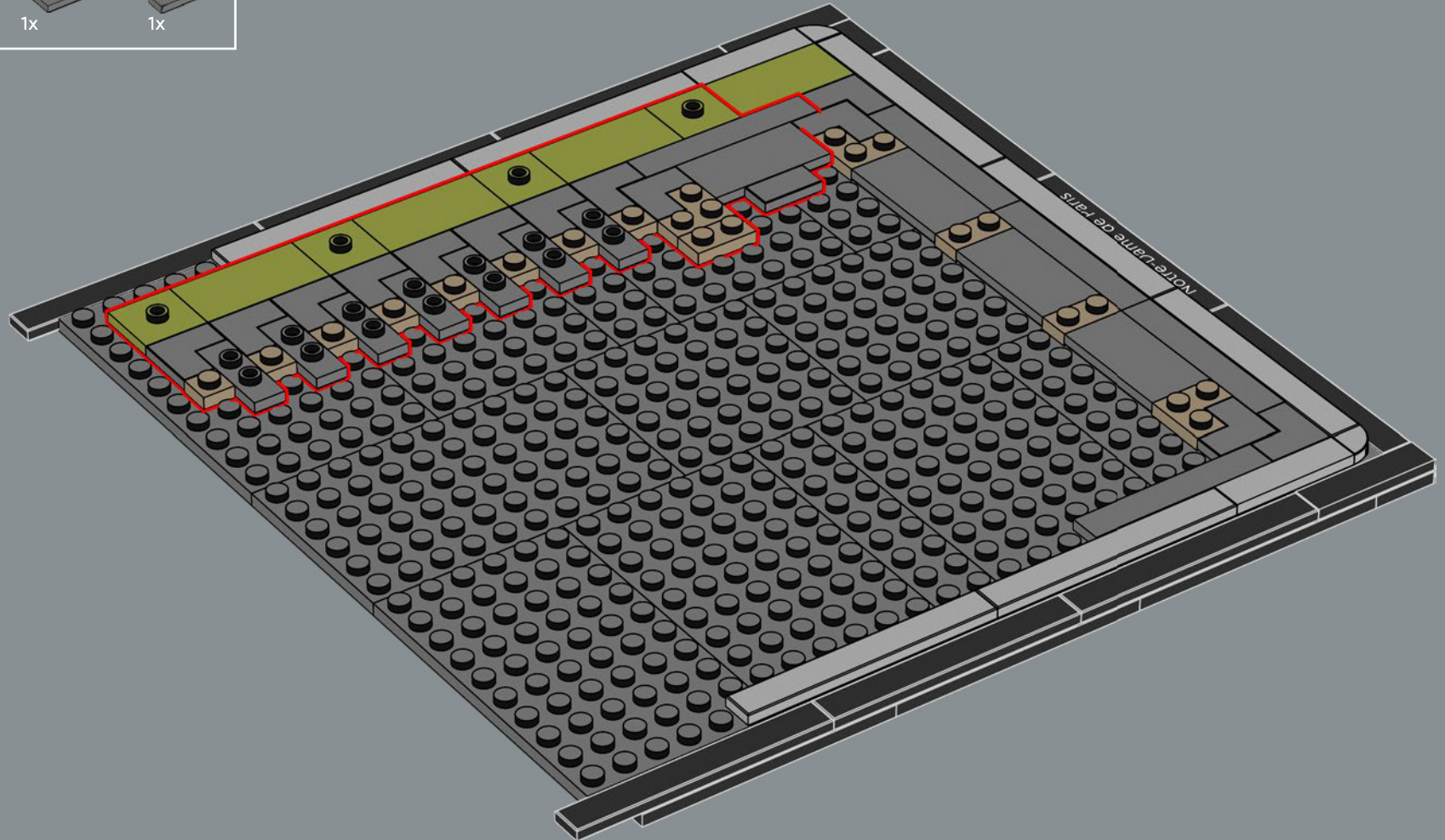

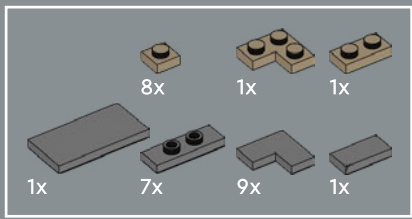

135

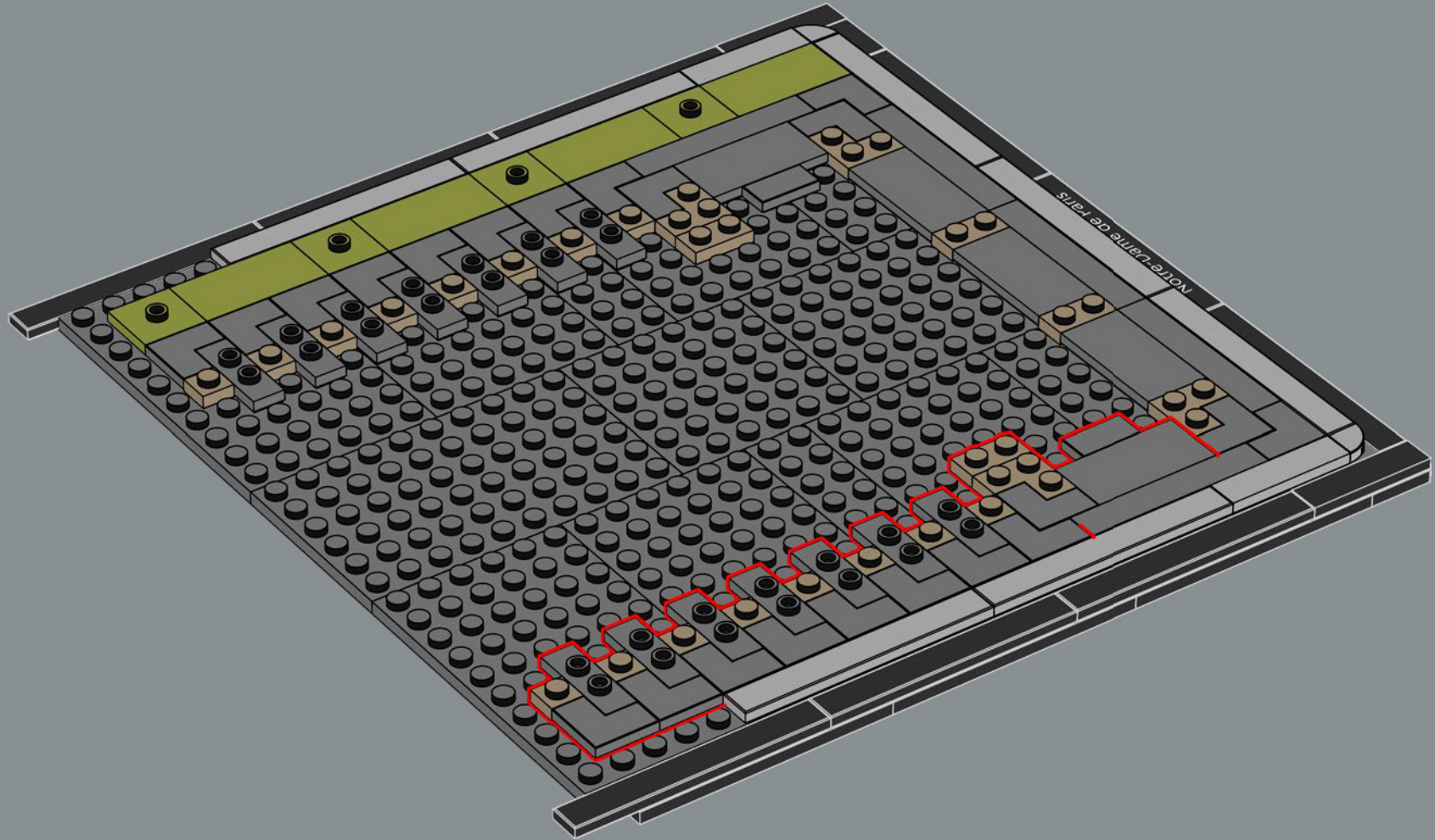



136

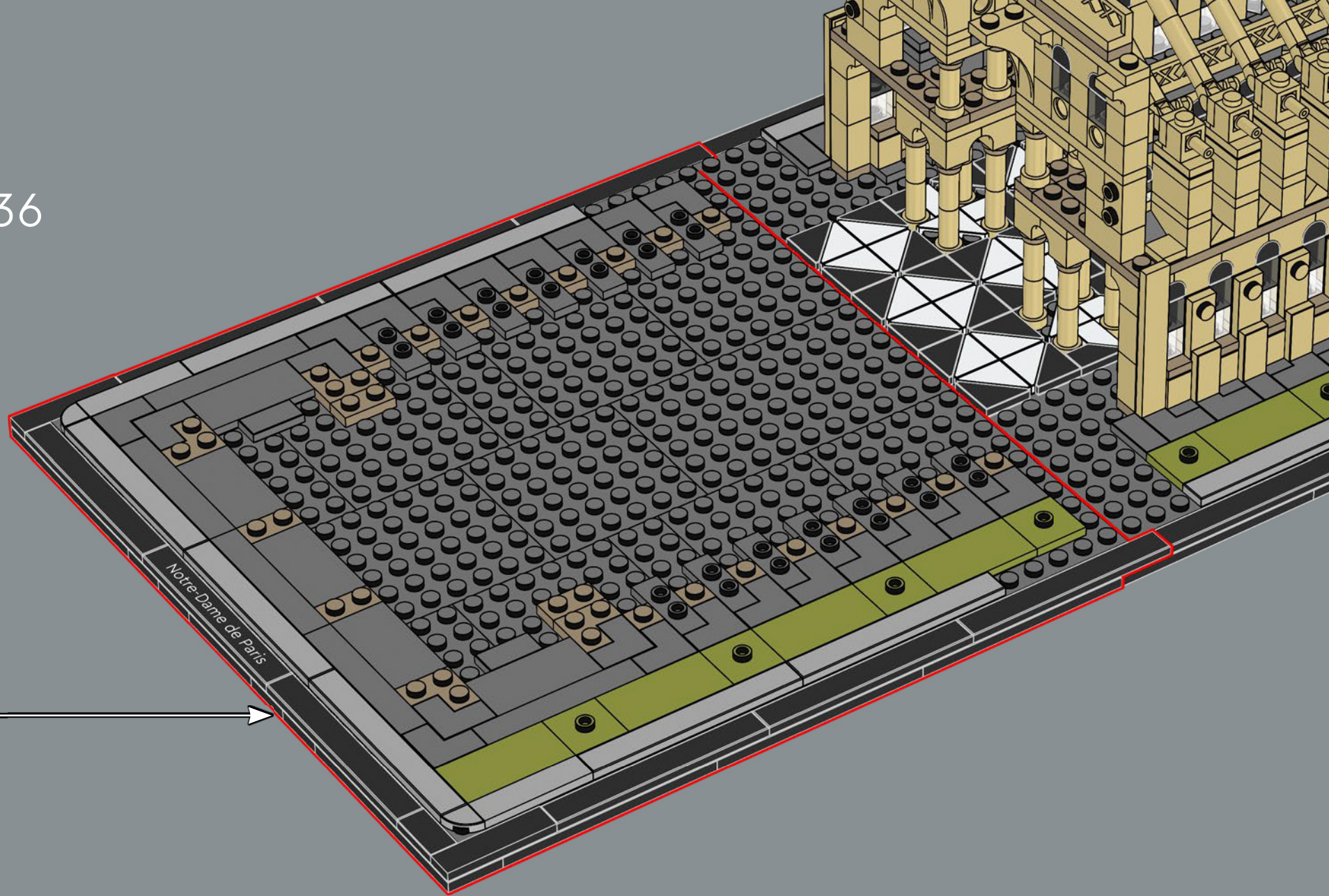

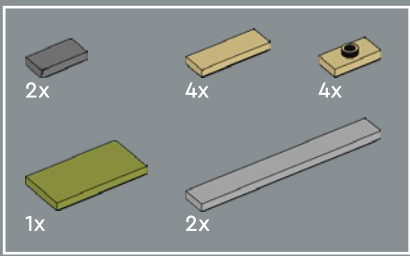

137

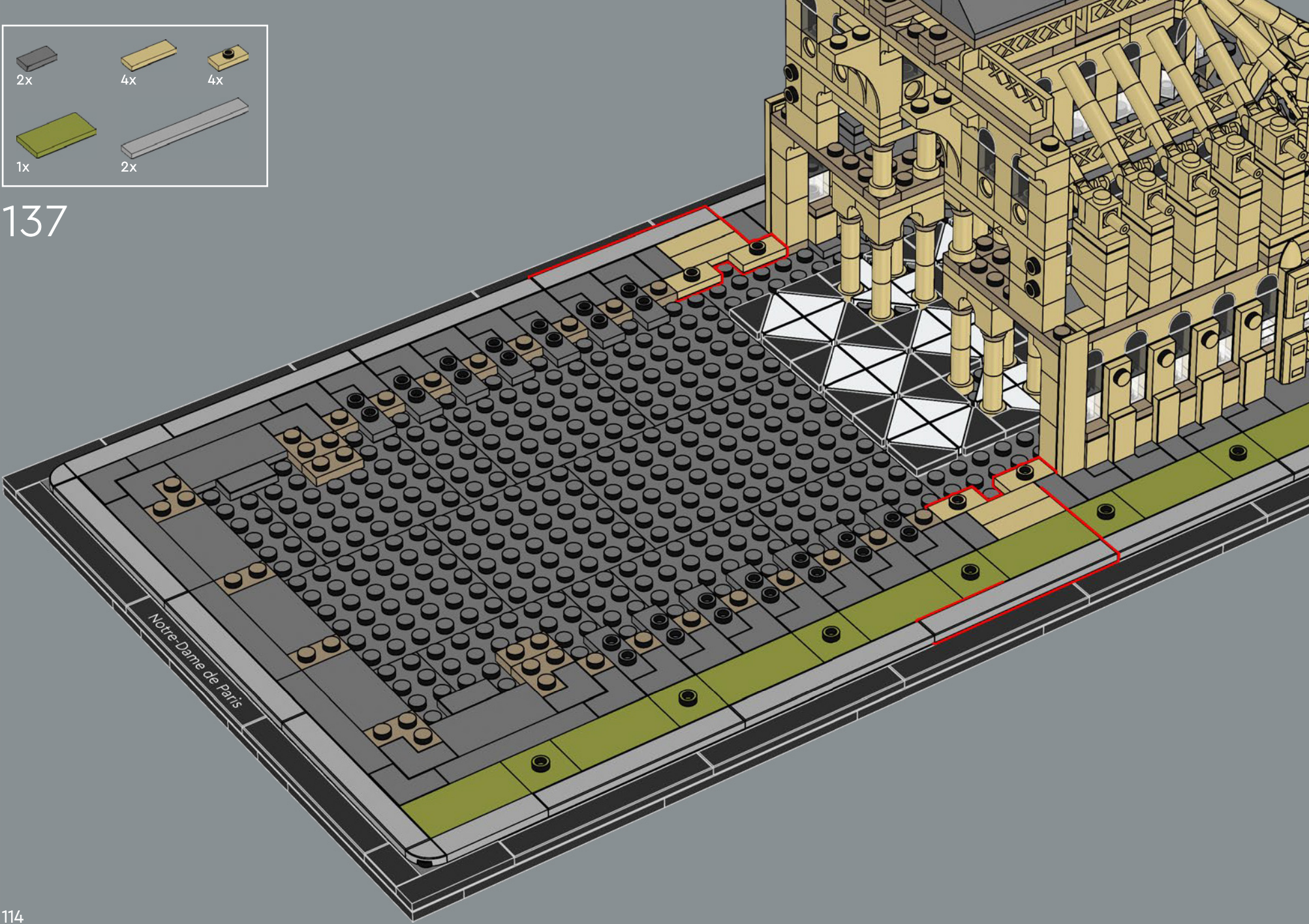

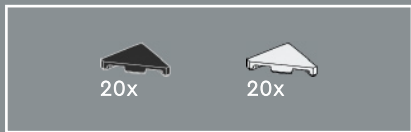

138

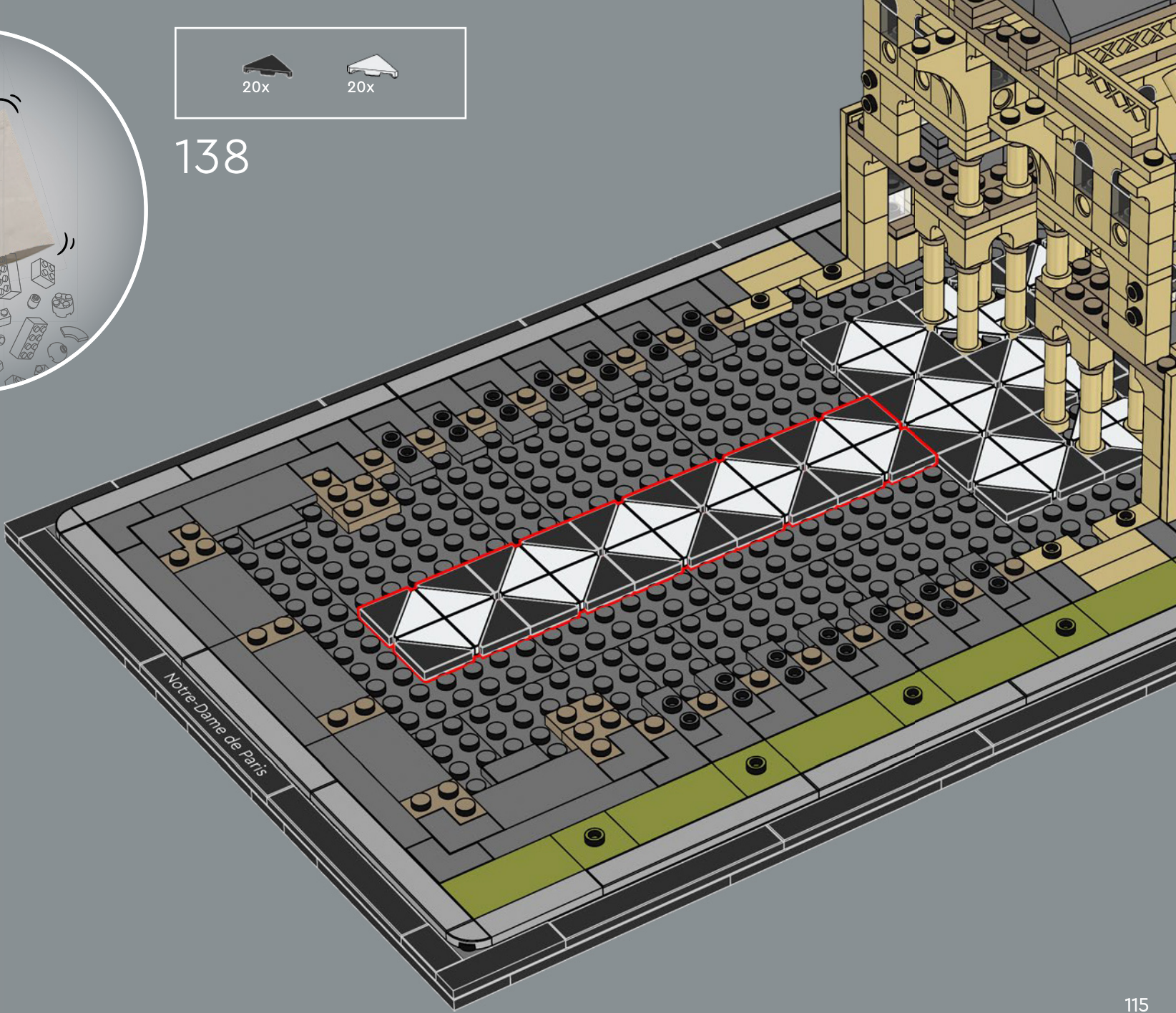

2x 30x

139

30x

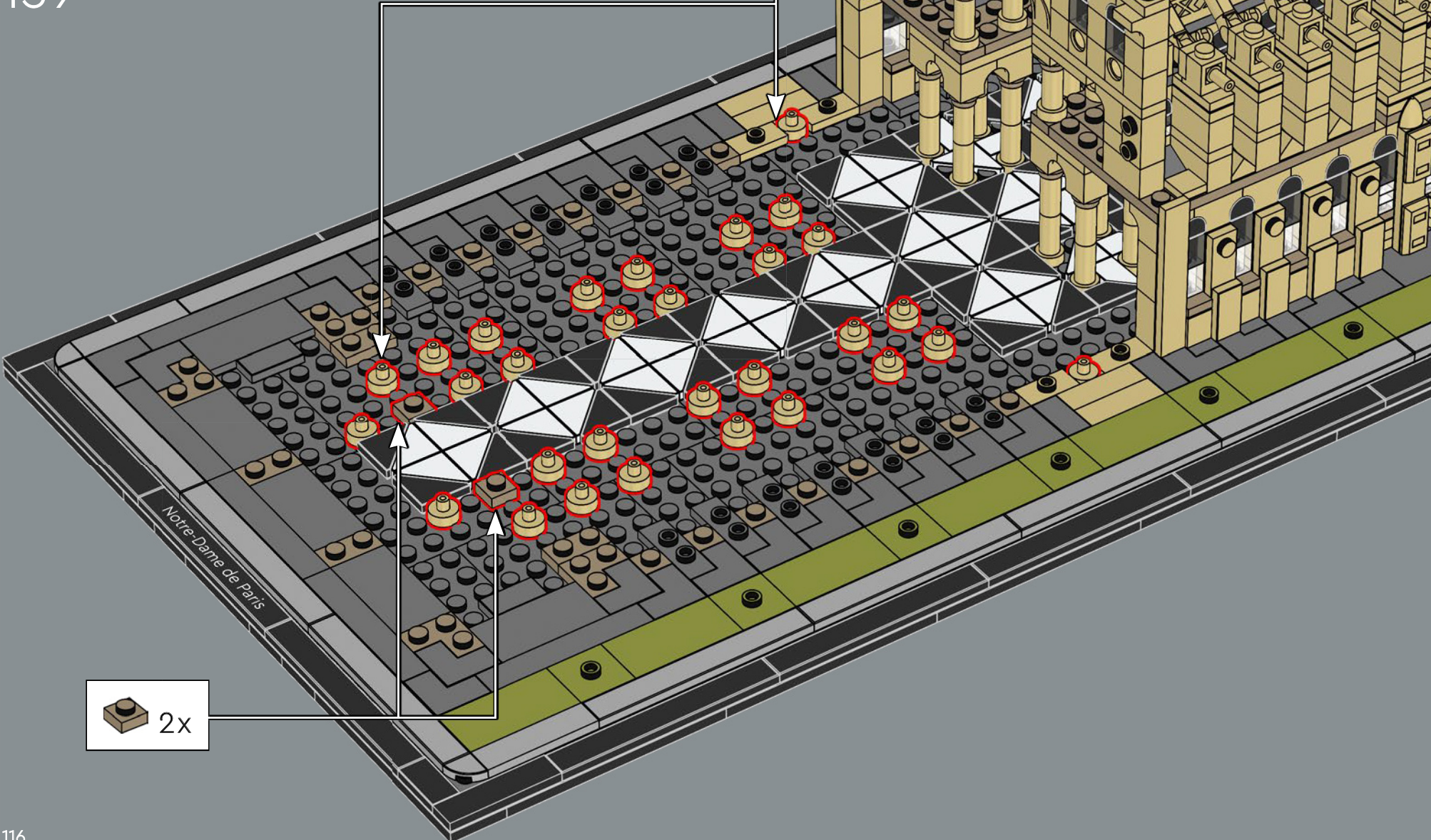

2x

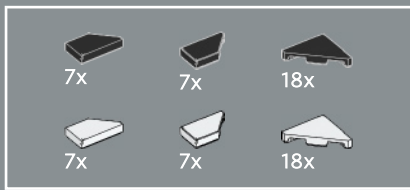

140

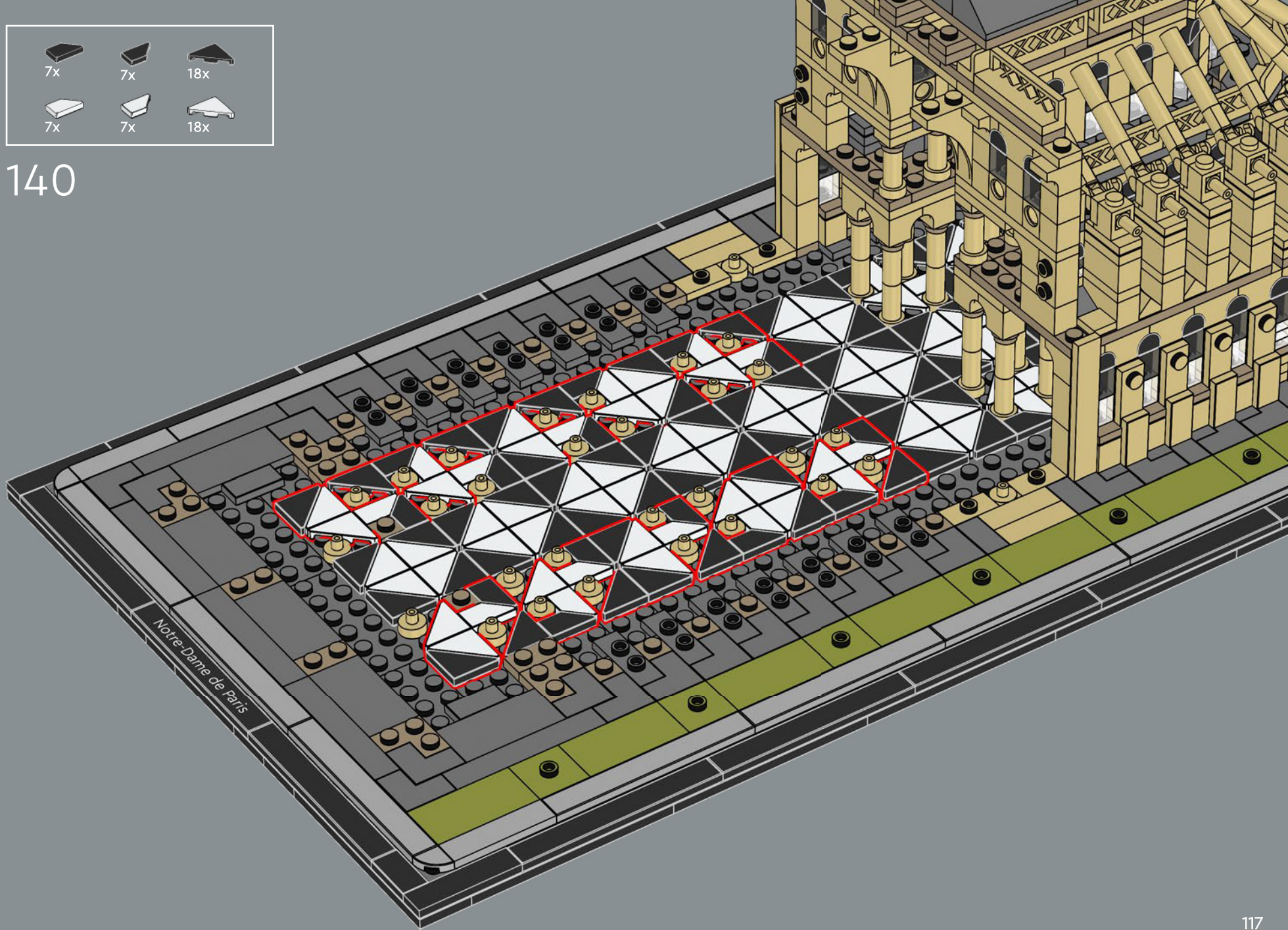

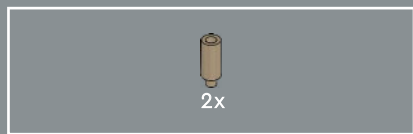

141

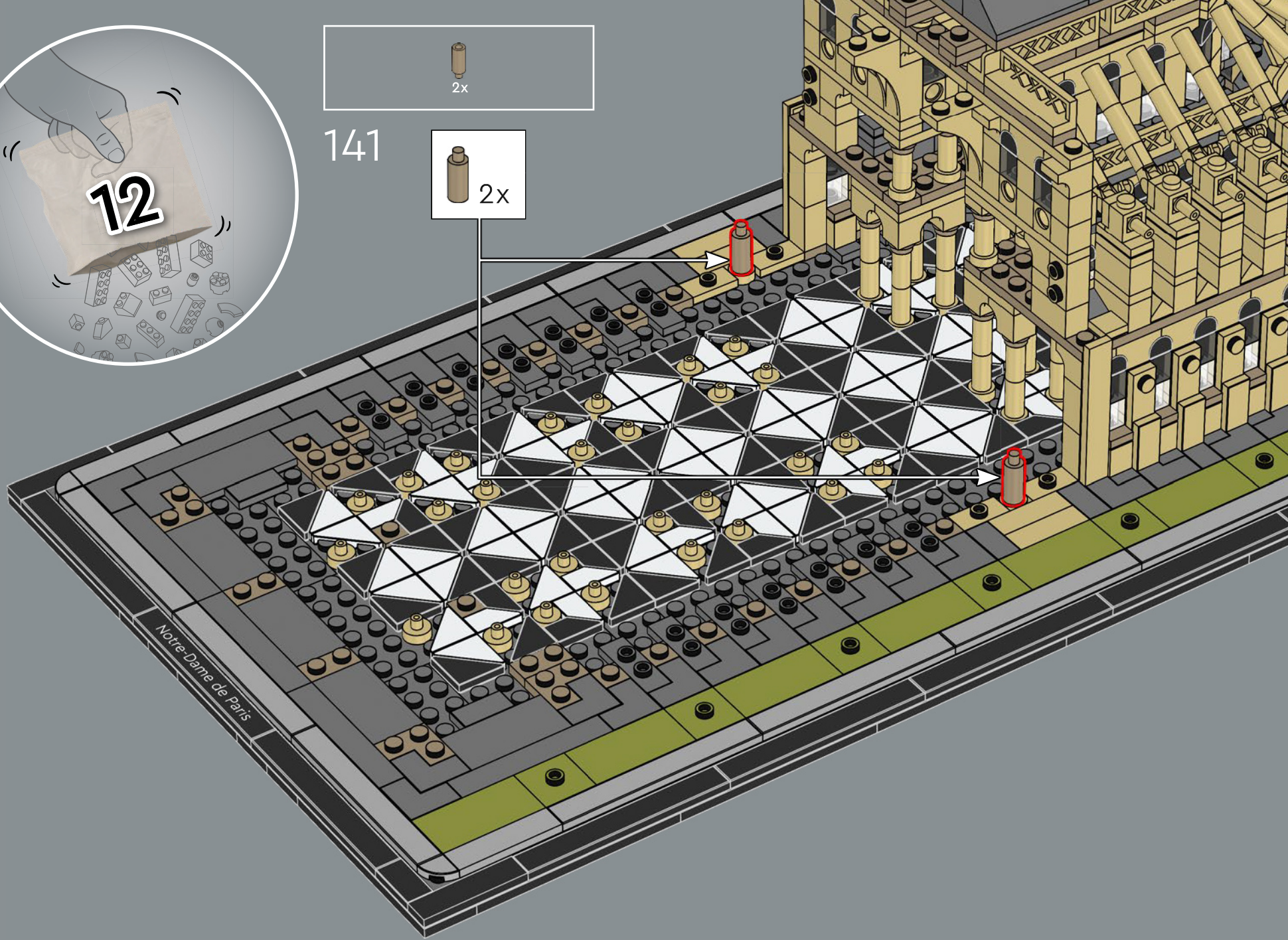
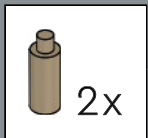

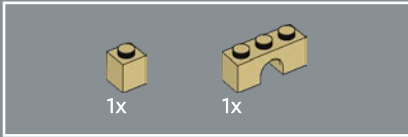
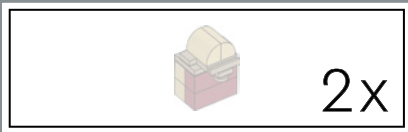

142

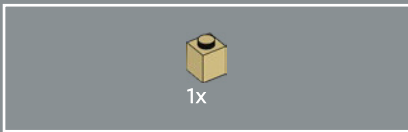
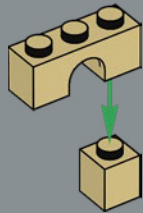

143

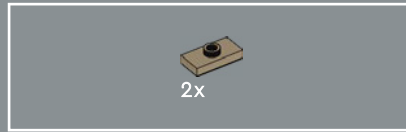
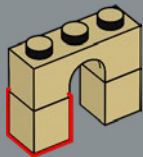

144

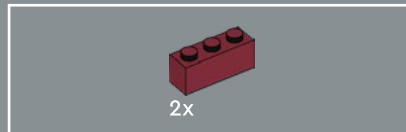
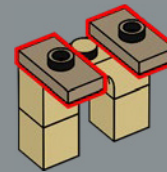

145

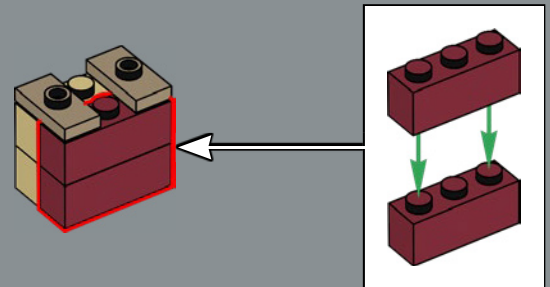

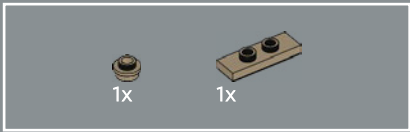

146

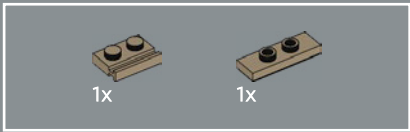
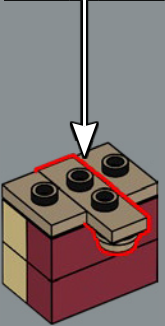
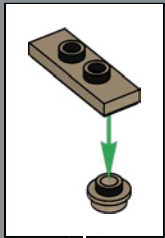

147

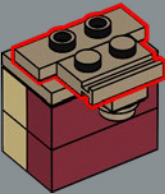

148

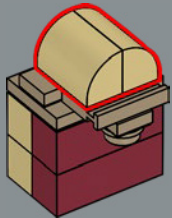

2x





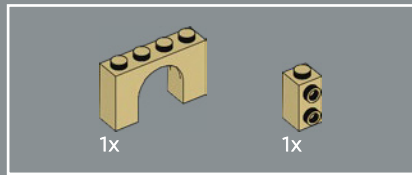
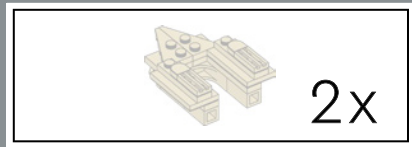

150

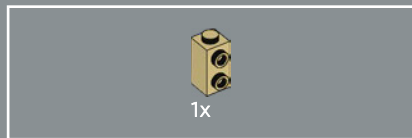
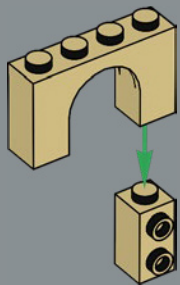

151

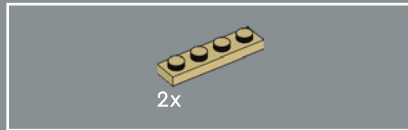
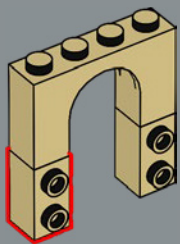

152

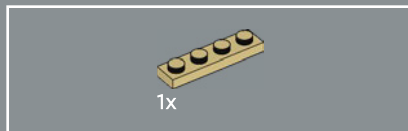
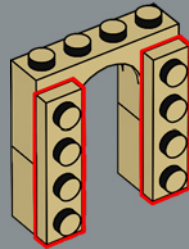

153

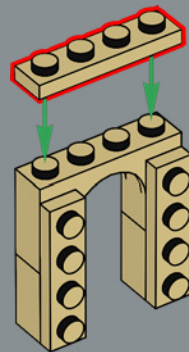

154

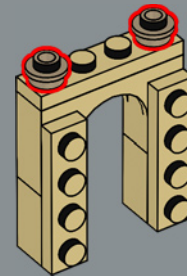

155

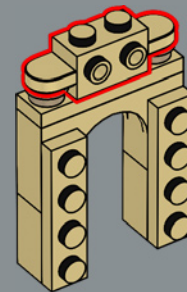

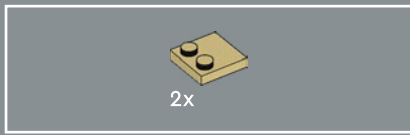

156

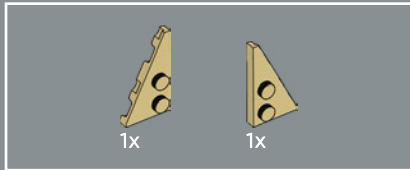
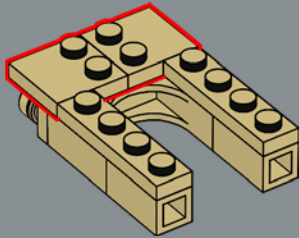

157

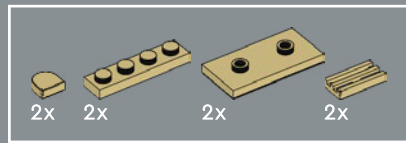
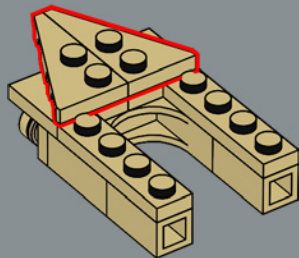

158

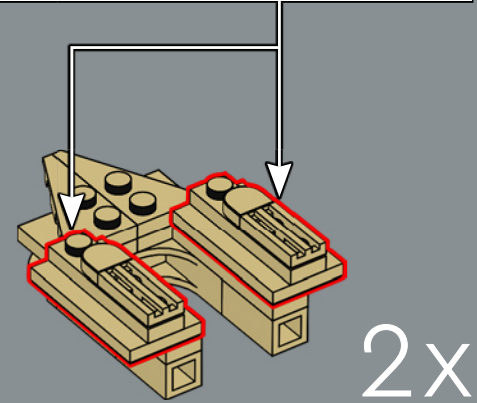
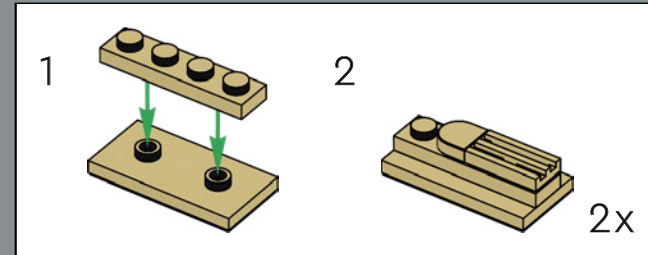

1182 - Il coro viene isolato dal cantiere attivo mediante un muro provvisorio. La costruzione prosegue da est a ovest nel transetto e nella navata.

159

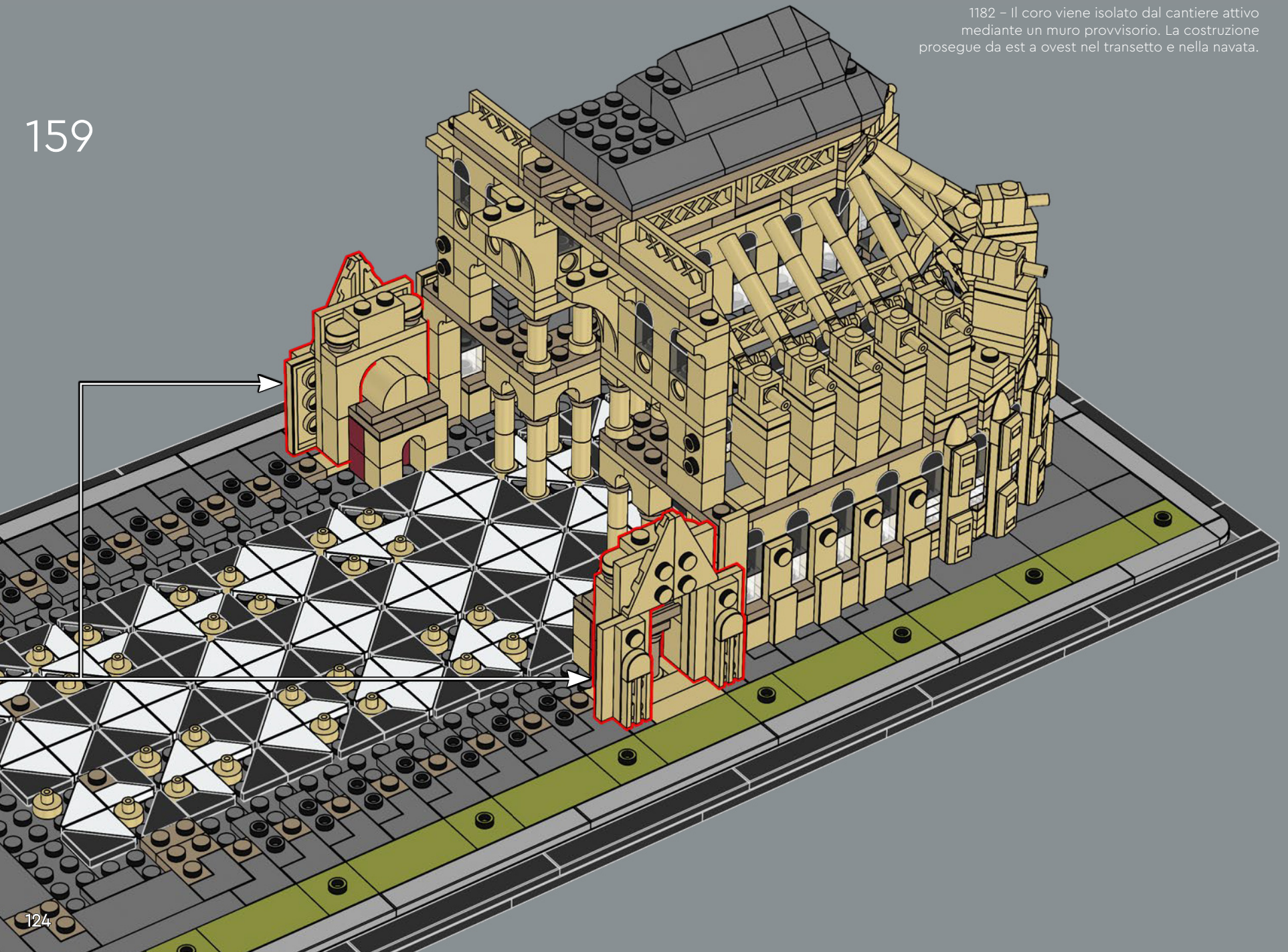

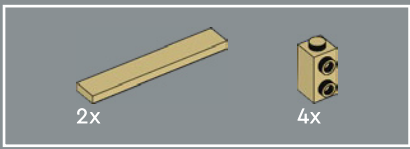

160

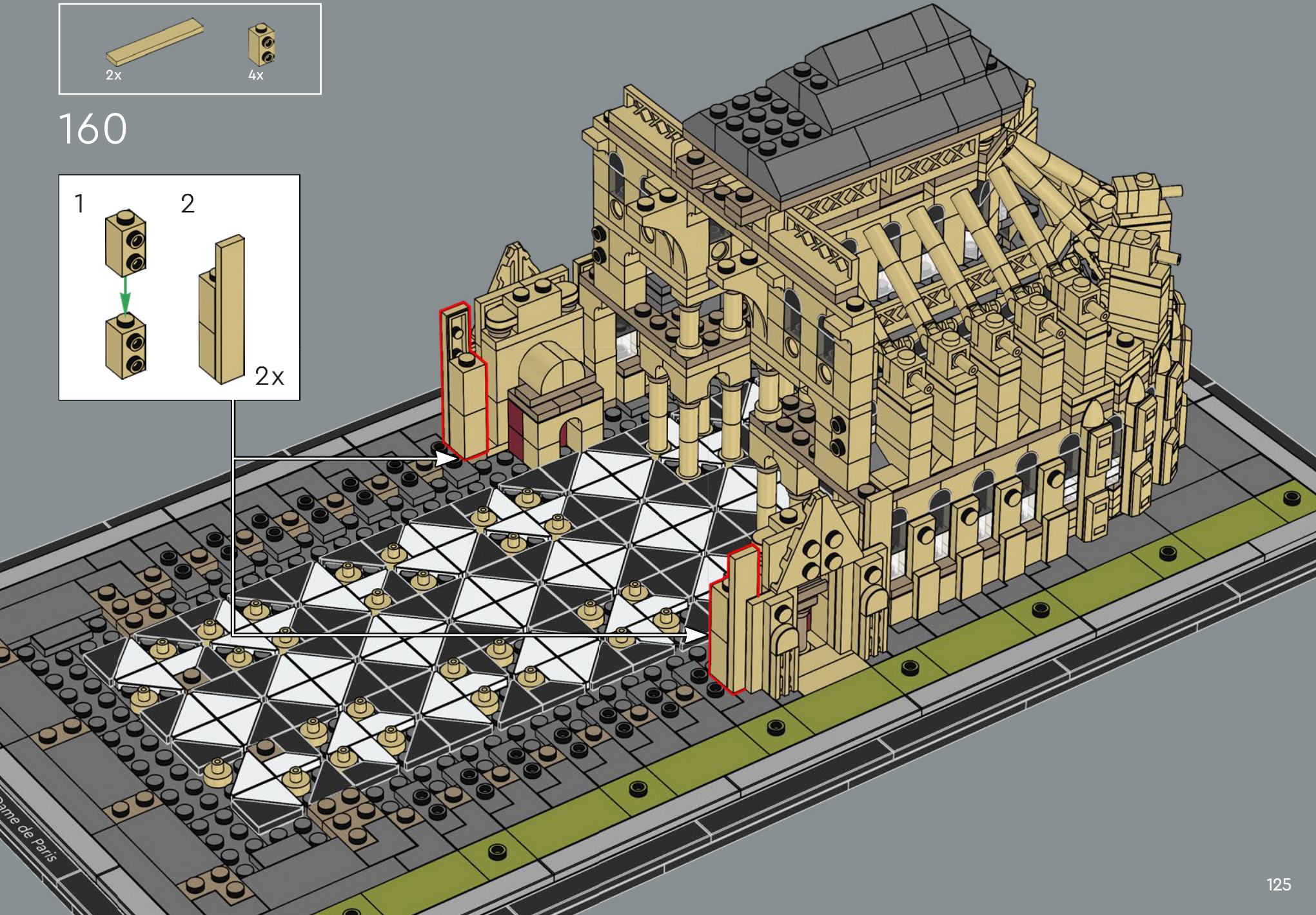
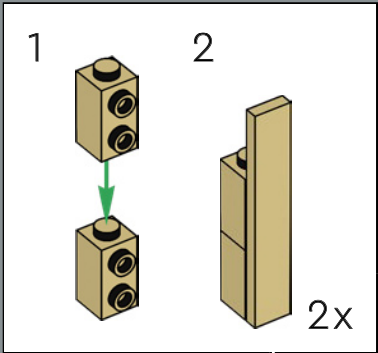

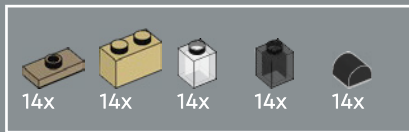

161

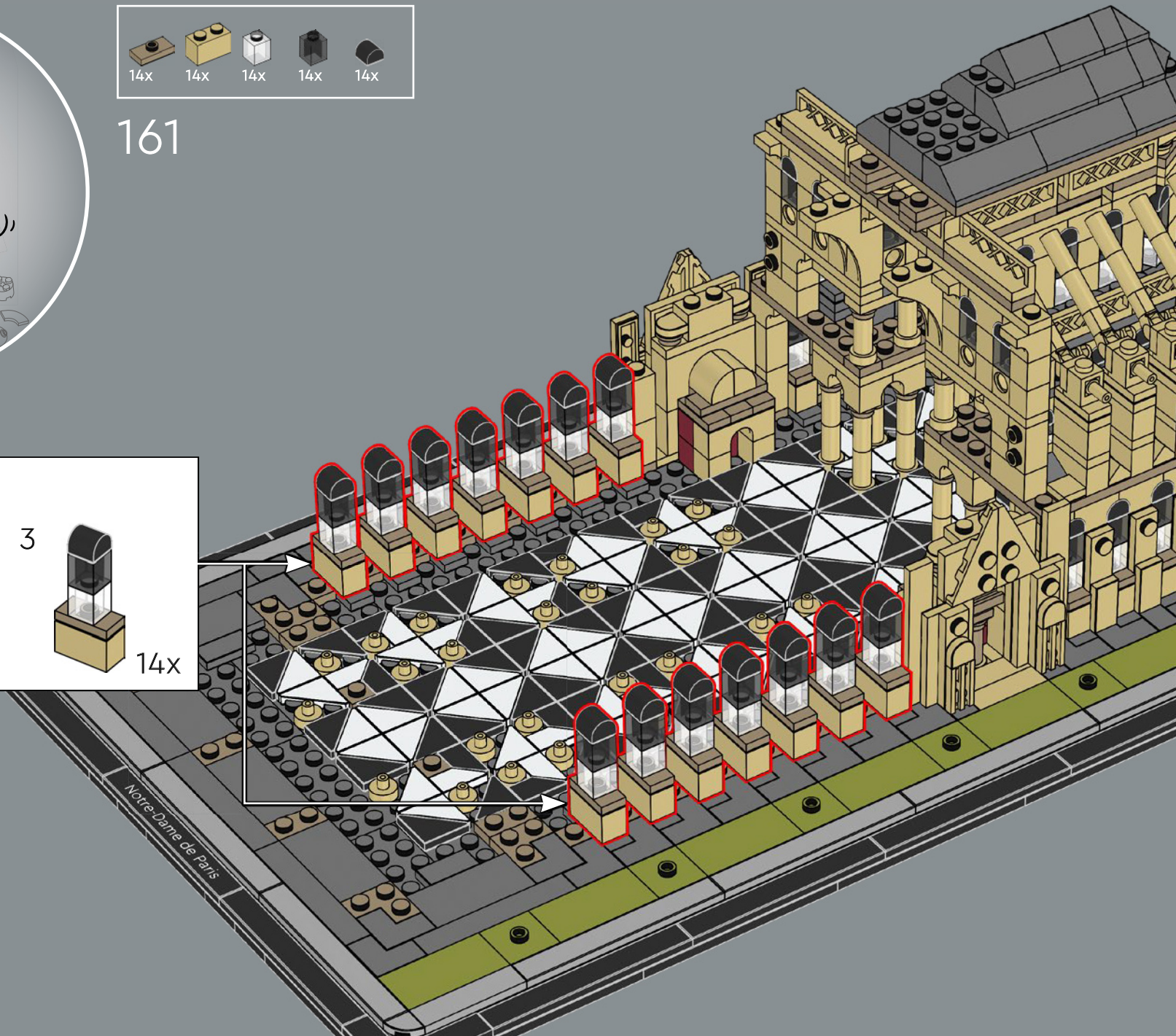
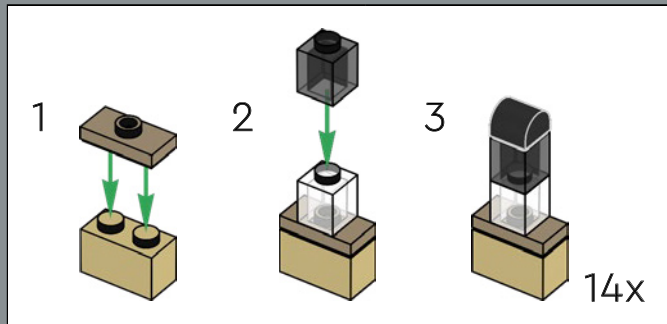

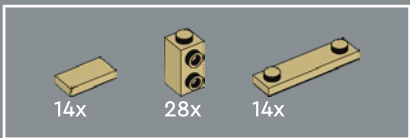

162

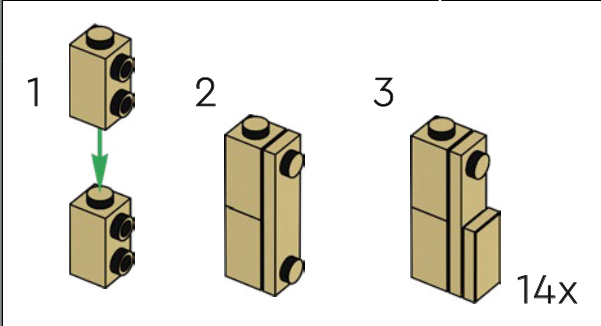
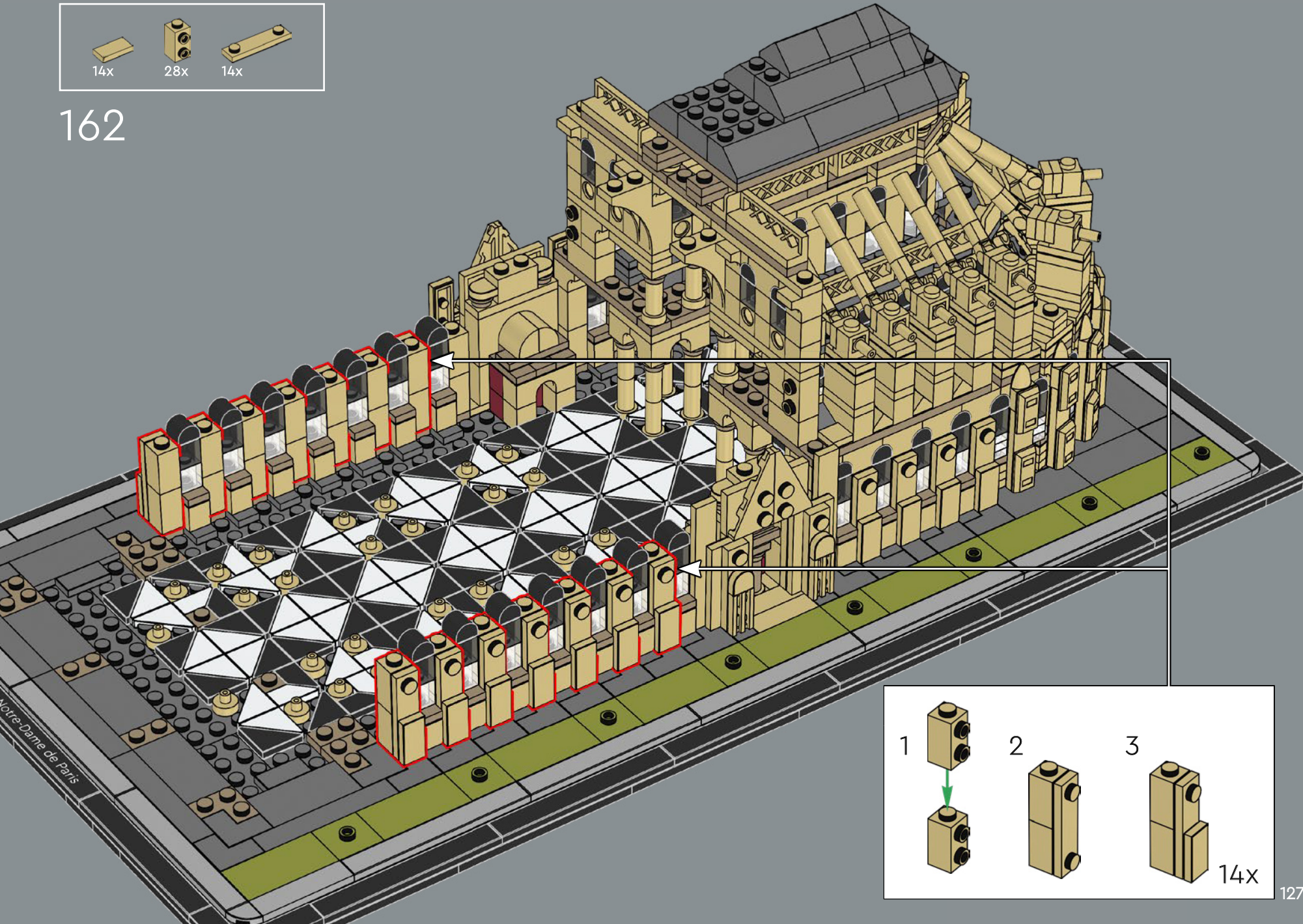



12x



4x

163







164

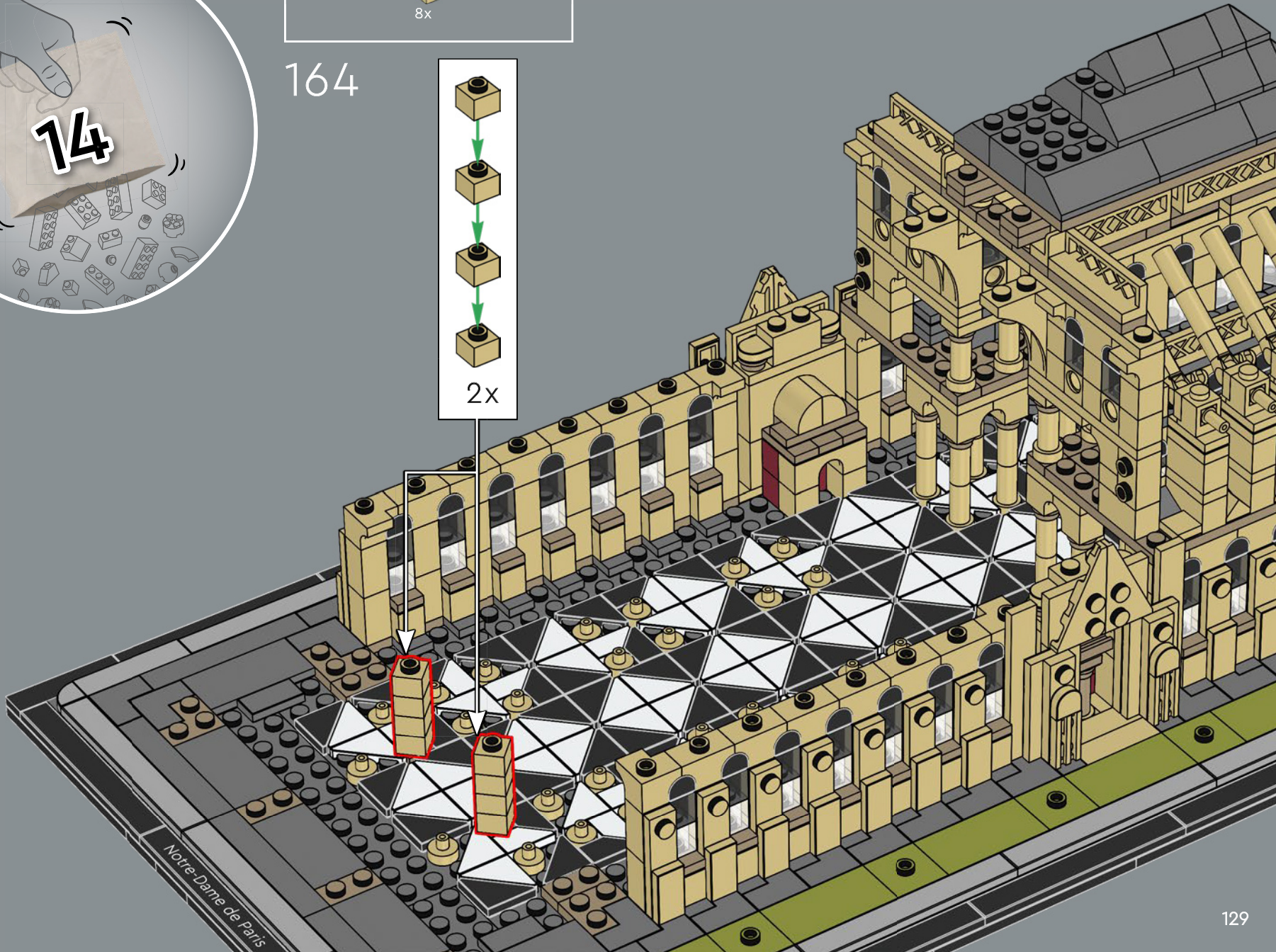
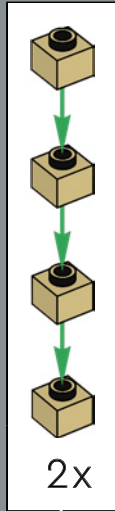



56x

165



28x

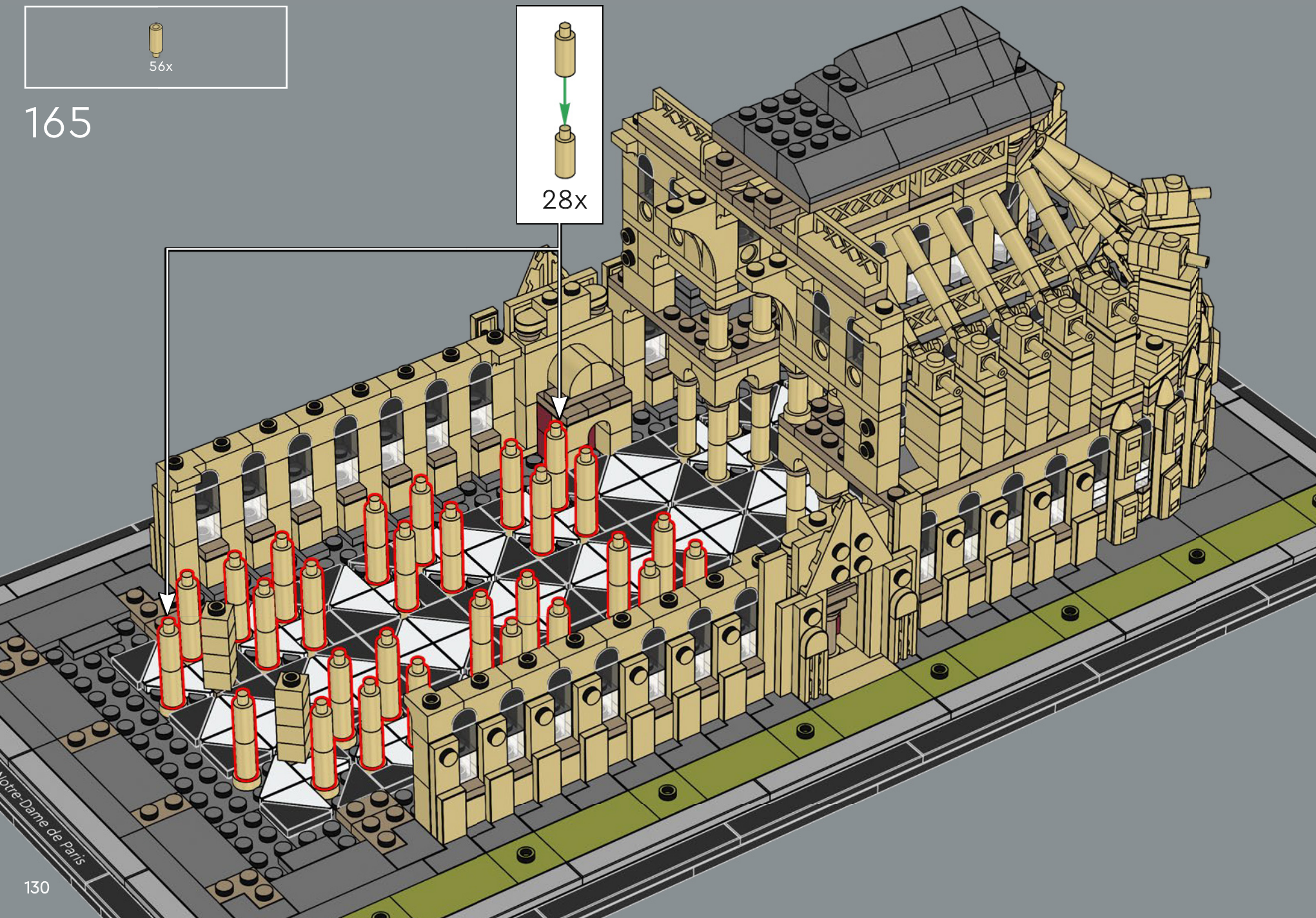

Notre-Dame de Paris

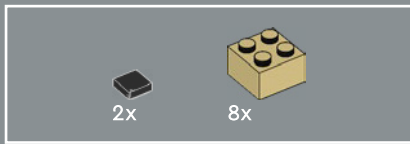

166

1208 - Proseguono i lavori nella navata centrale e vengono gettate le fondamenta delle grandi torri occidentali.

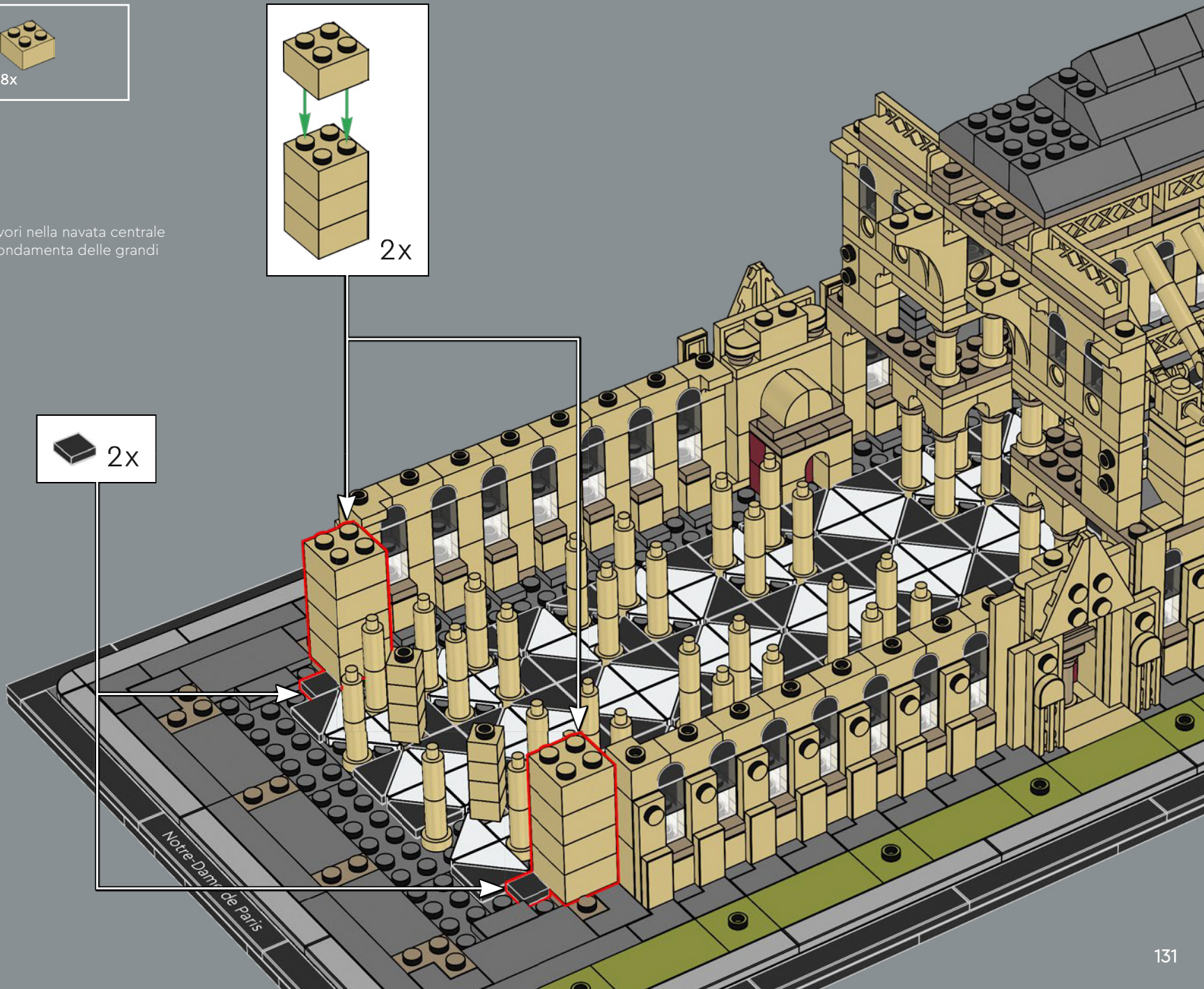
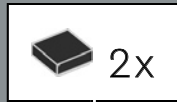
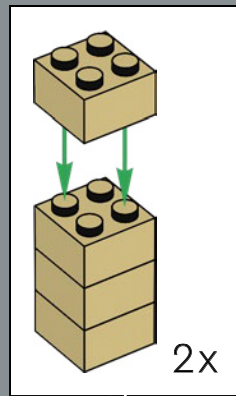

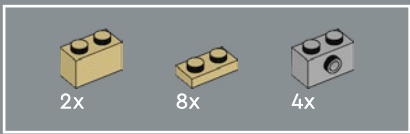

167

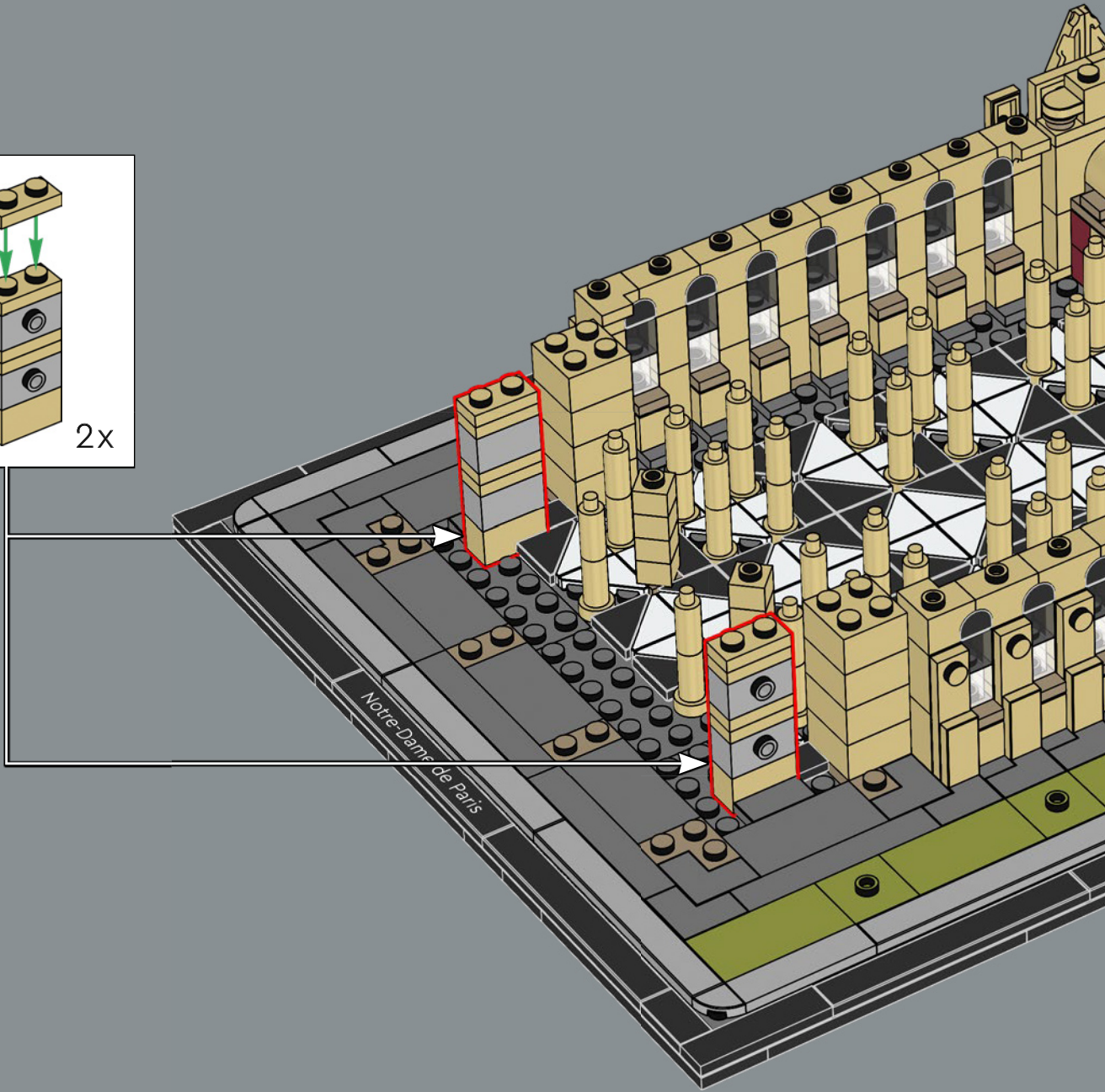
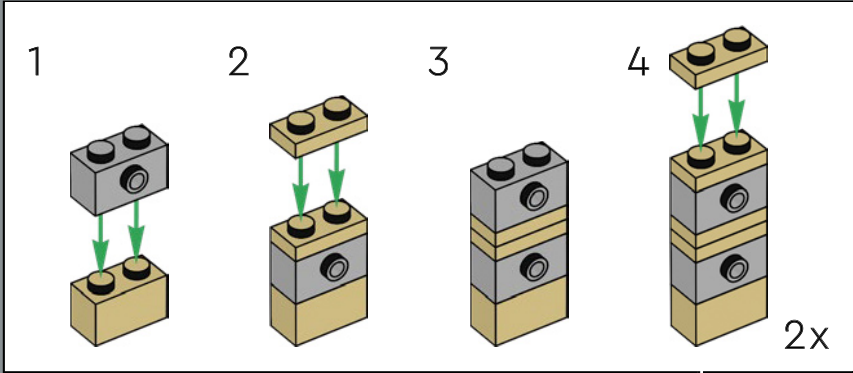

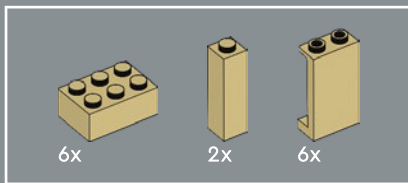

168

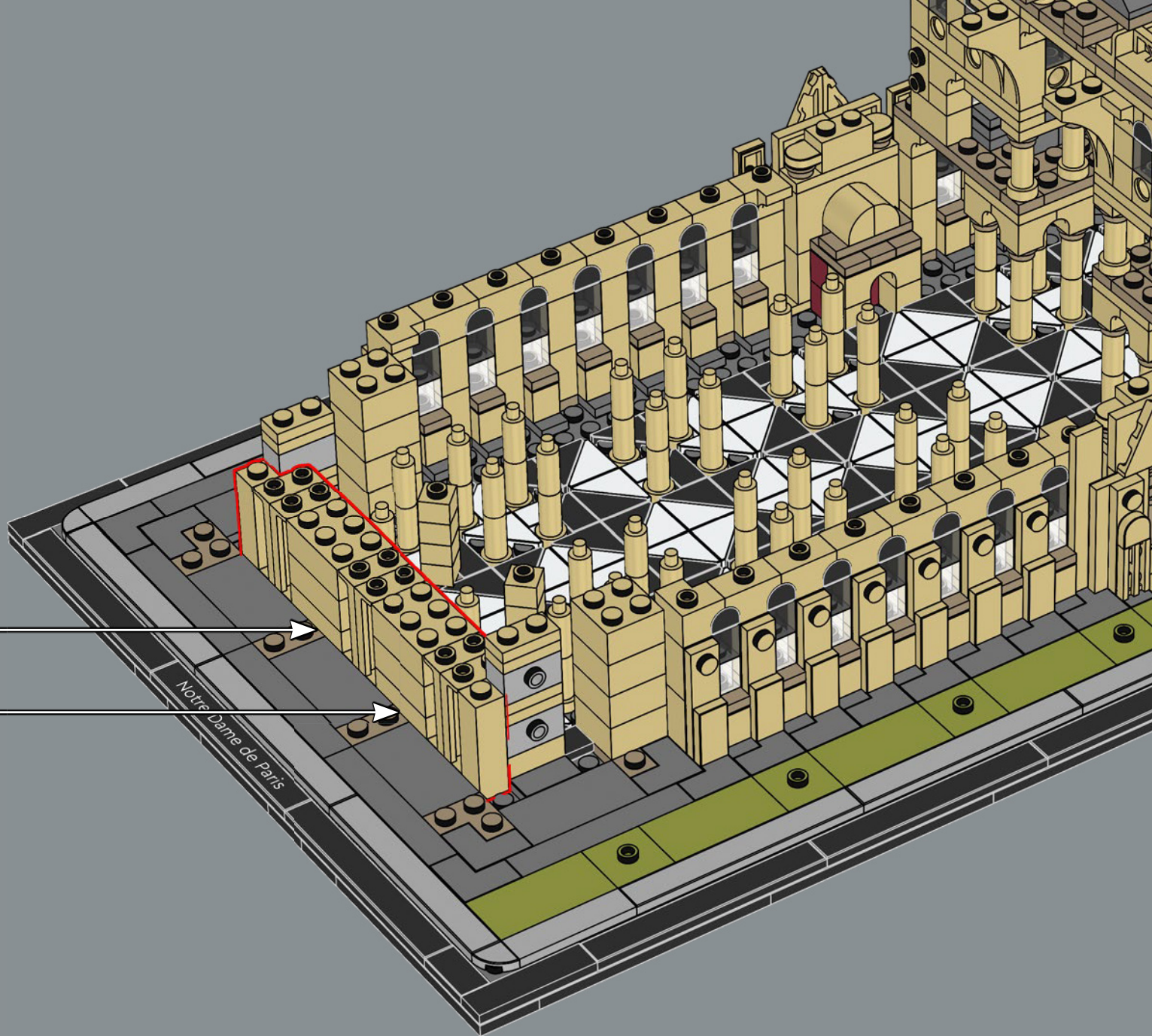
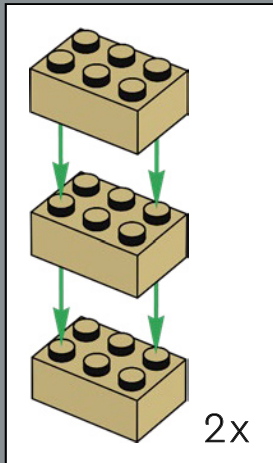

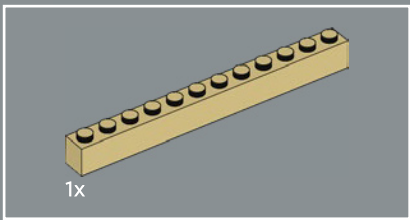

169

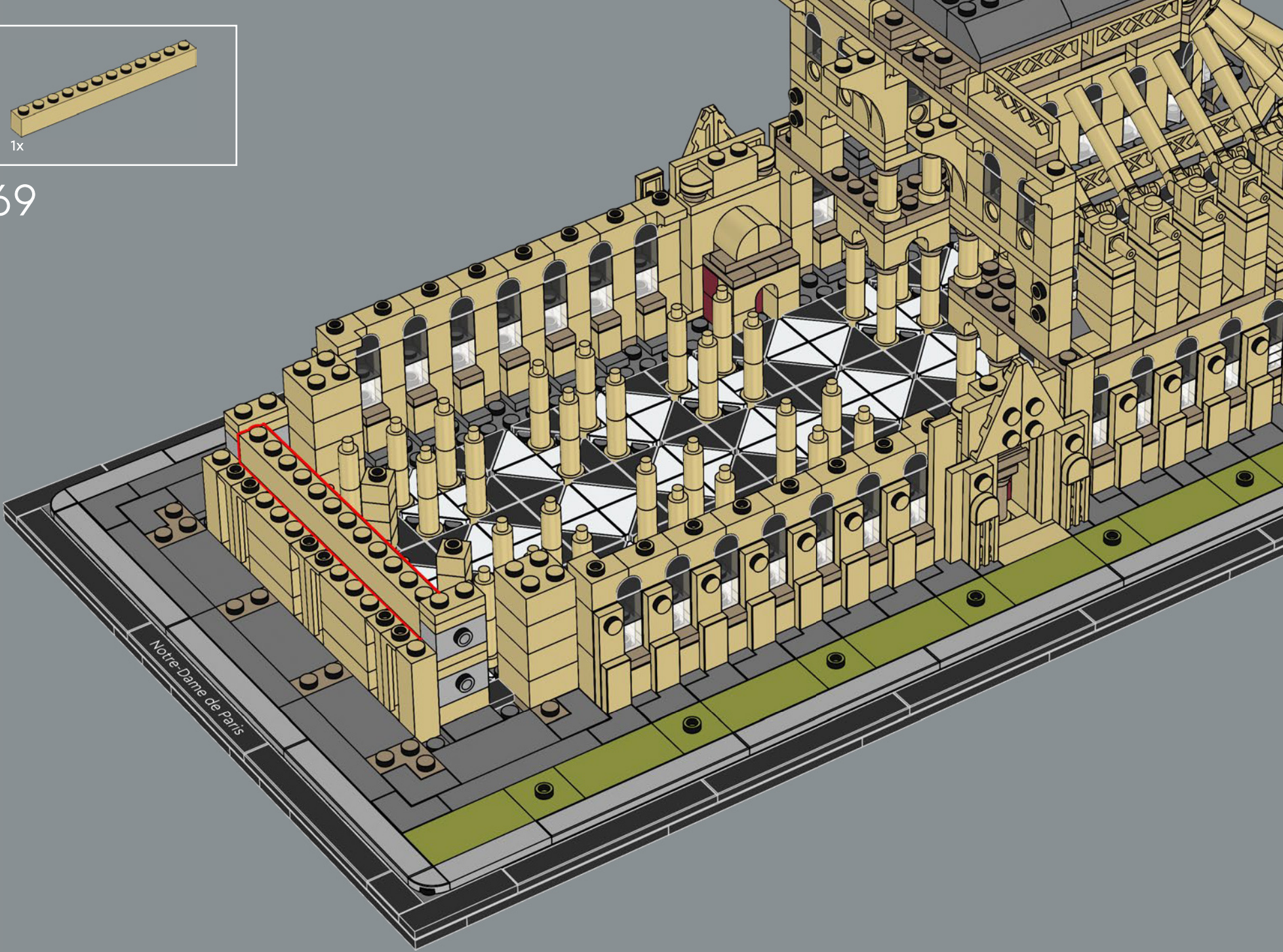



170

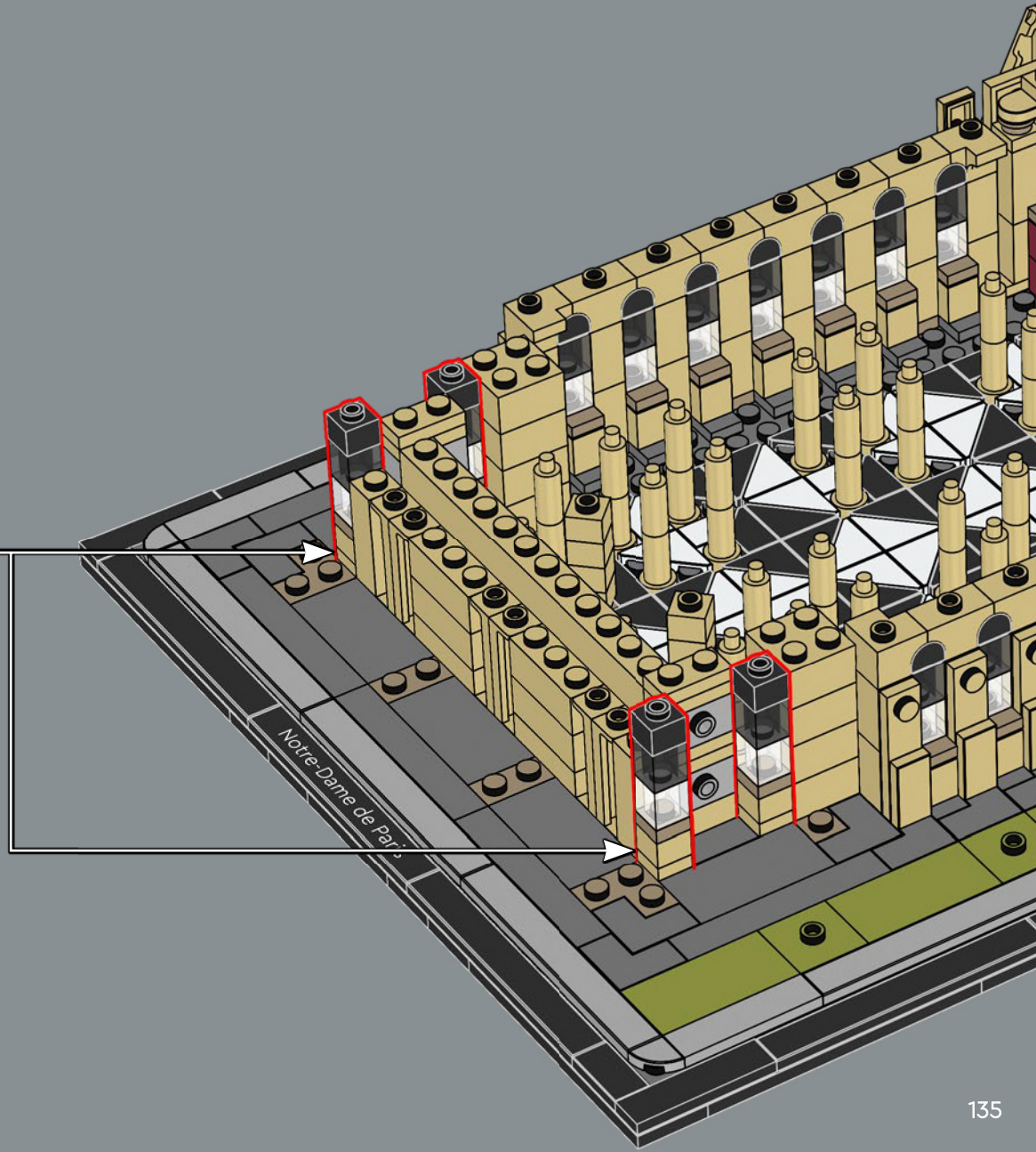
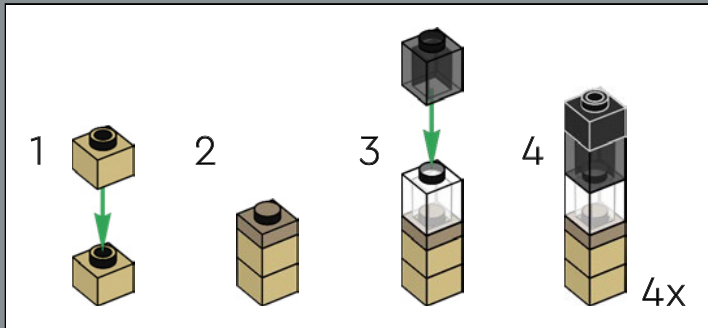

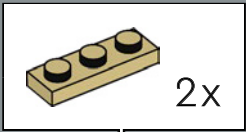
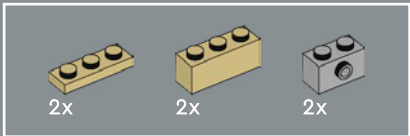

171

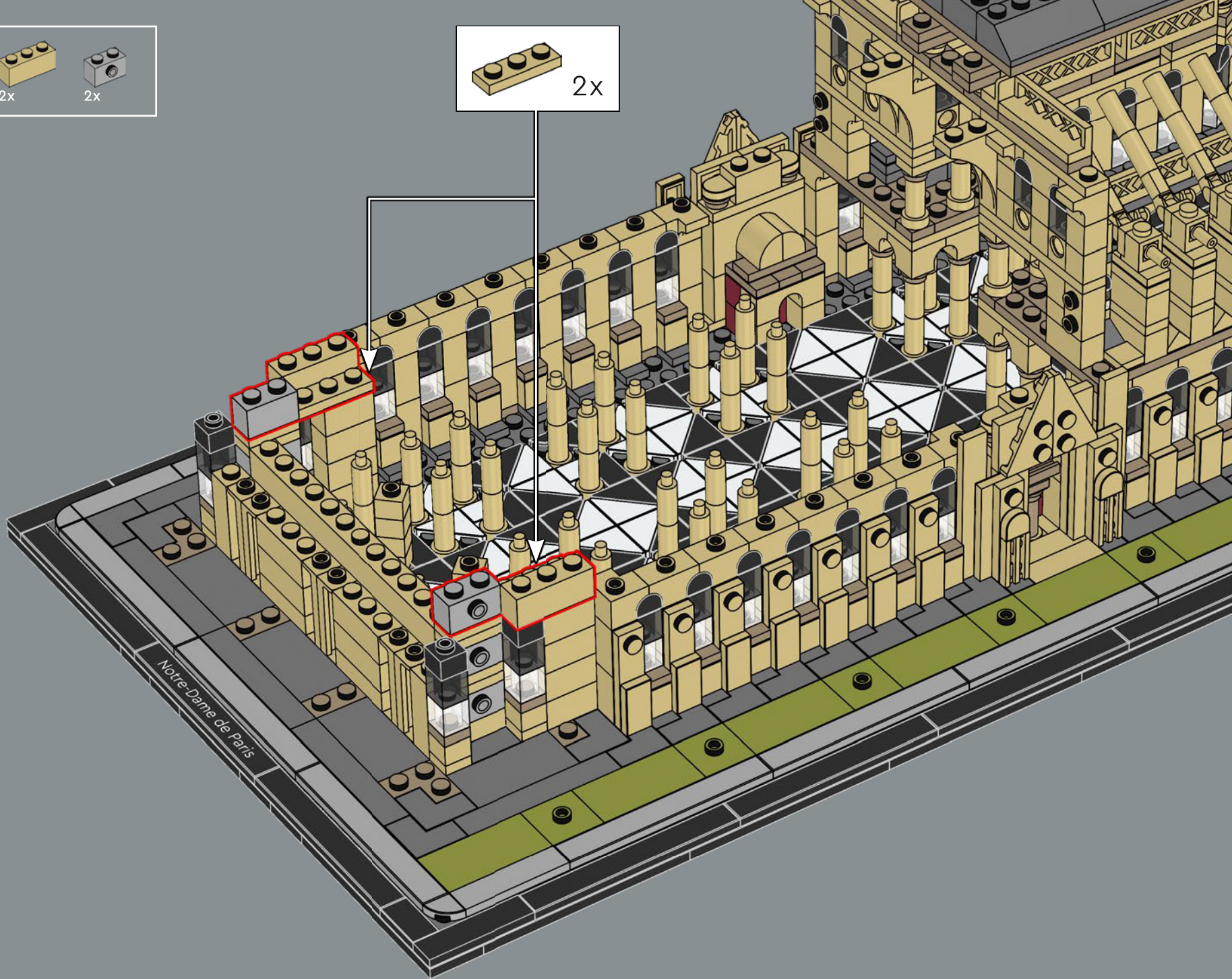



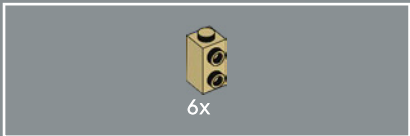

172

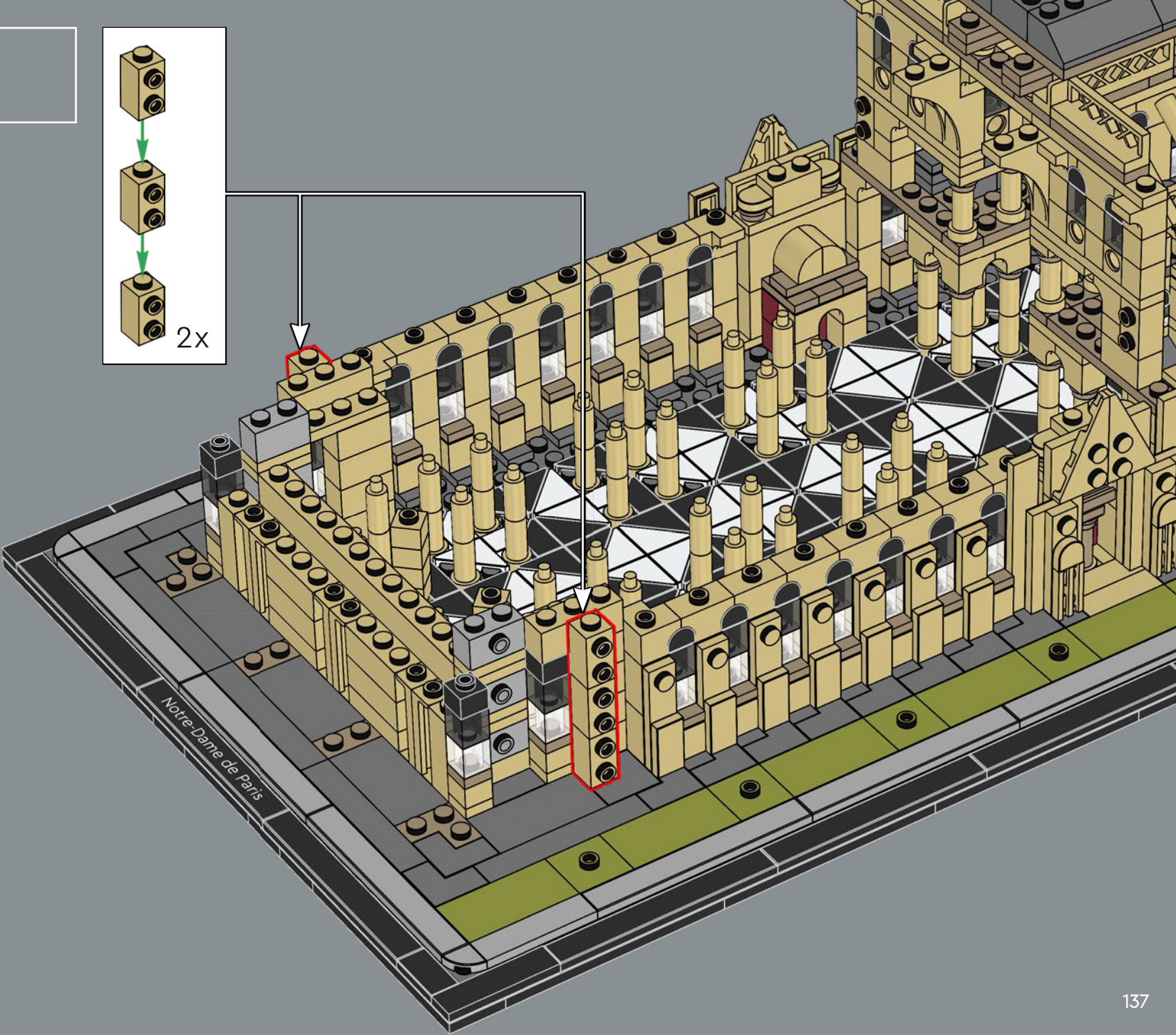
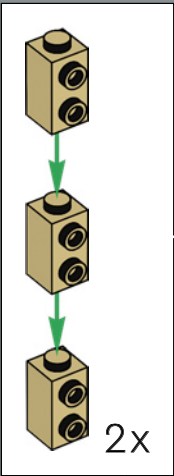

## TECNICHE E CARATTERISTICHE COSTRUTTIVE

✂ Nel 1208, fu completata la costruzione del transetto, con grandi rosoni sulle facciate, tutti di dimensioni e design diversi. Il rosone nord originale ha un diametro di 13,5 m, un record per l'epoca. Ogni elemento architettonico della cattedrale ha uno scopo, sia decorativo sia pratico. I tre elementi del rosone LEGO® sono un'astrazione degli originali: hanno tutti le stesse dimensioni e lo stesso design ed è possibile usarli in modo intercambiabile nel modello. Nel 1220, il corpo della cattedrale è completo, ad eccezione della parte superiore delle torri.



*I caratteristici doccioni, evacuando l'acqua piovana, servono anche a proteggere la cattedrale dai danni causati da un eccessivo deflusso. Puoi vedere questa funzionalità riprodotta nel tuo modello.*



173

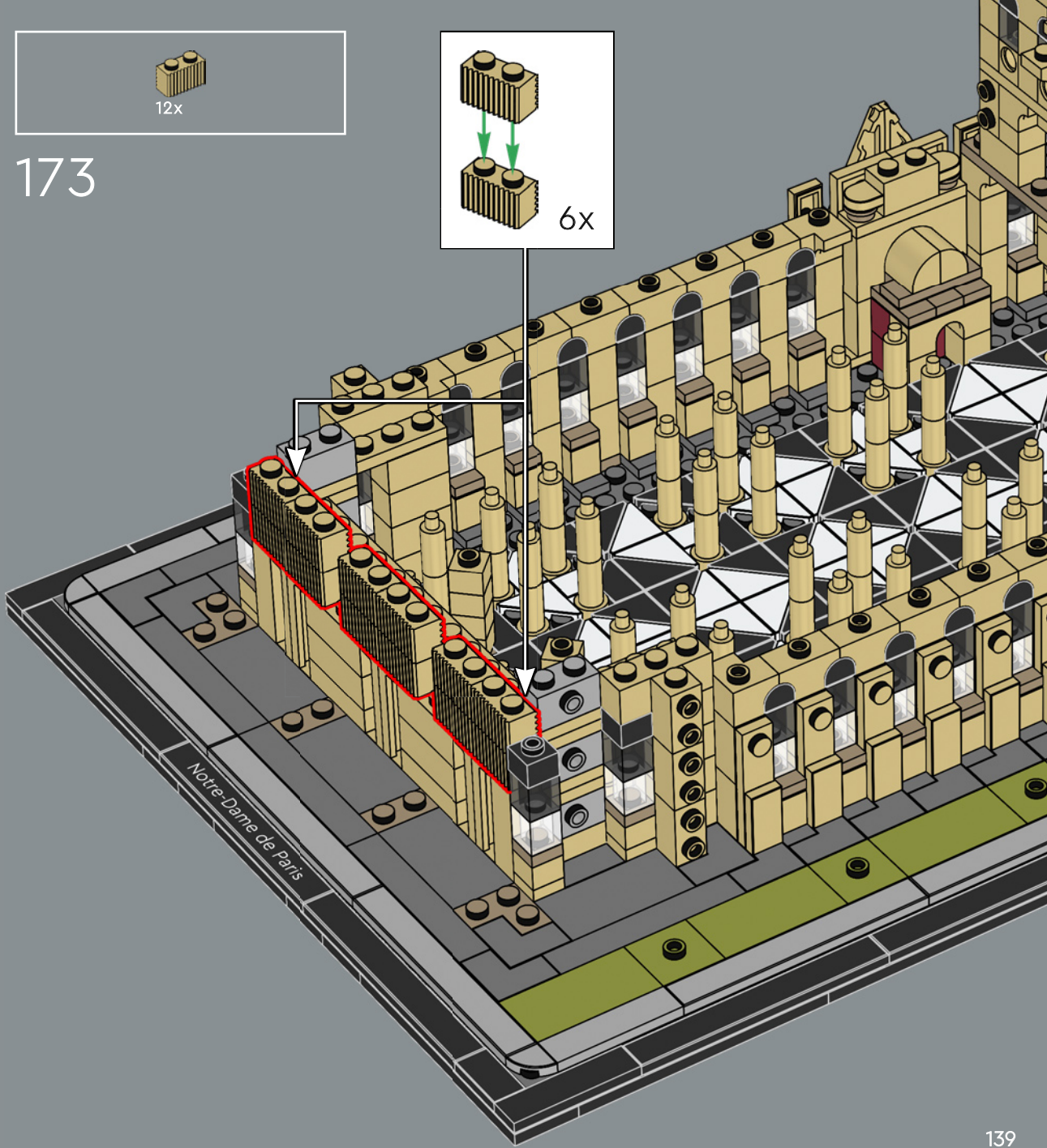
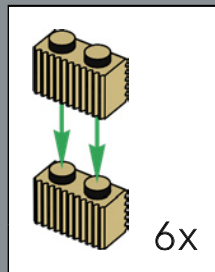

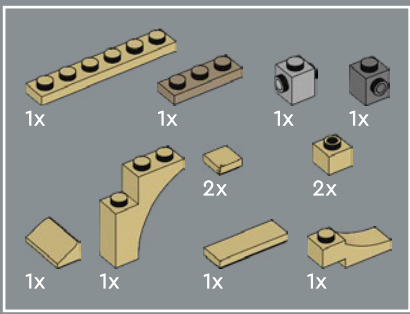

174

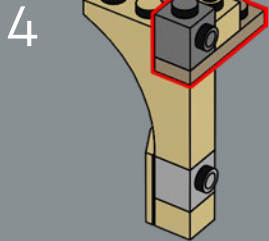
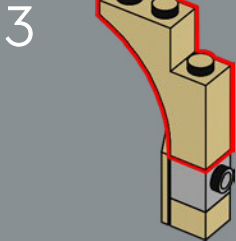
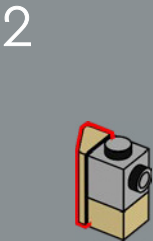
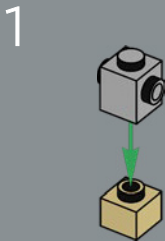
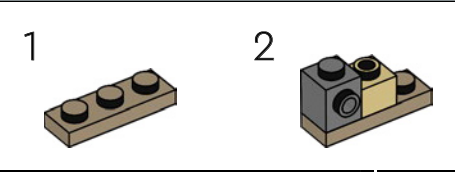

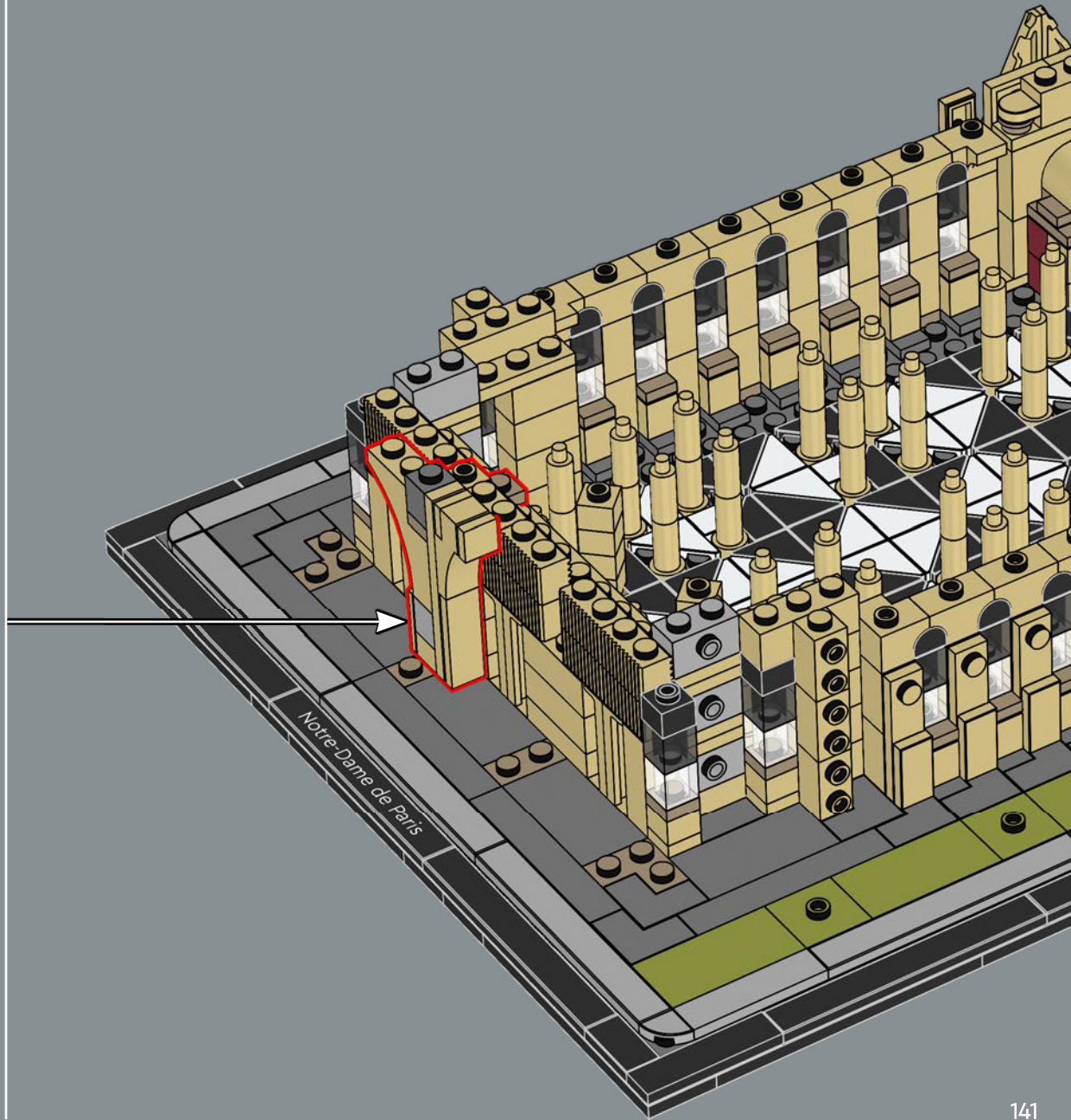
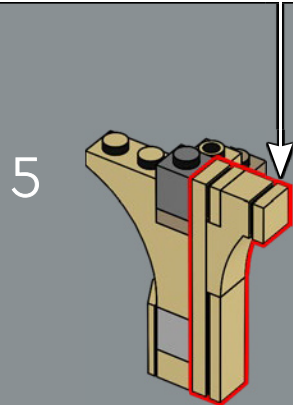
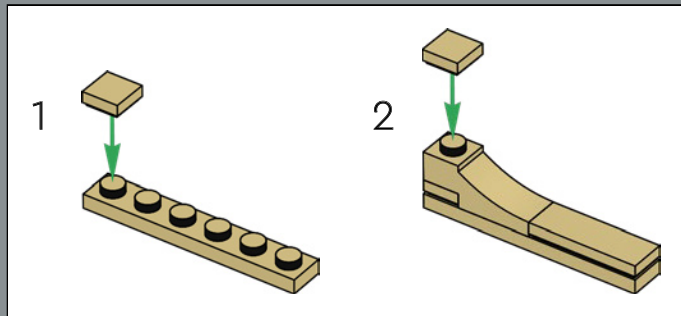

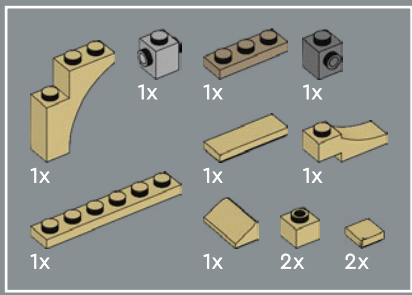

175

1

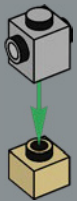

2



3

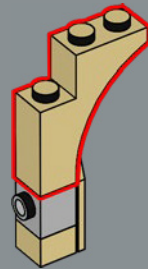

1

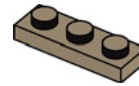

2

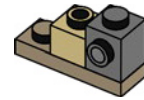

4

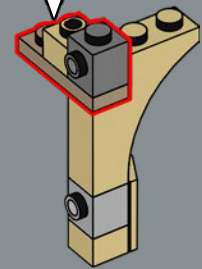

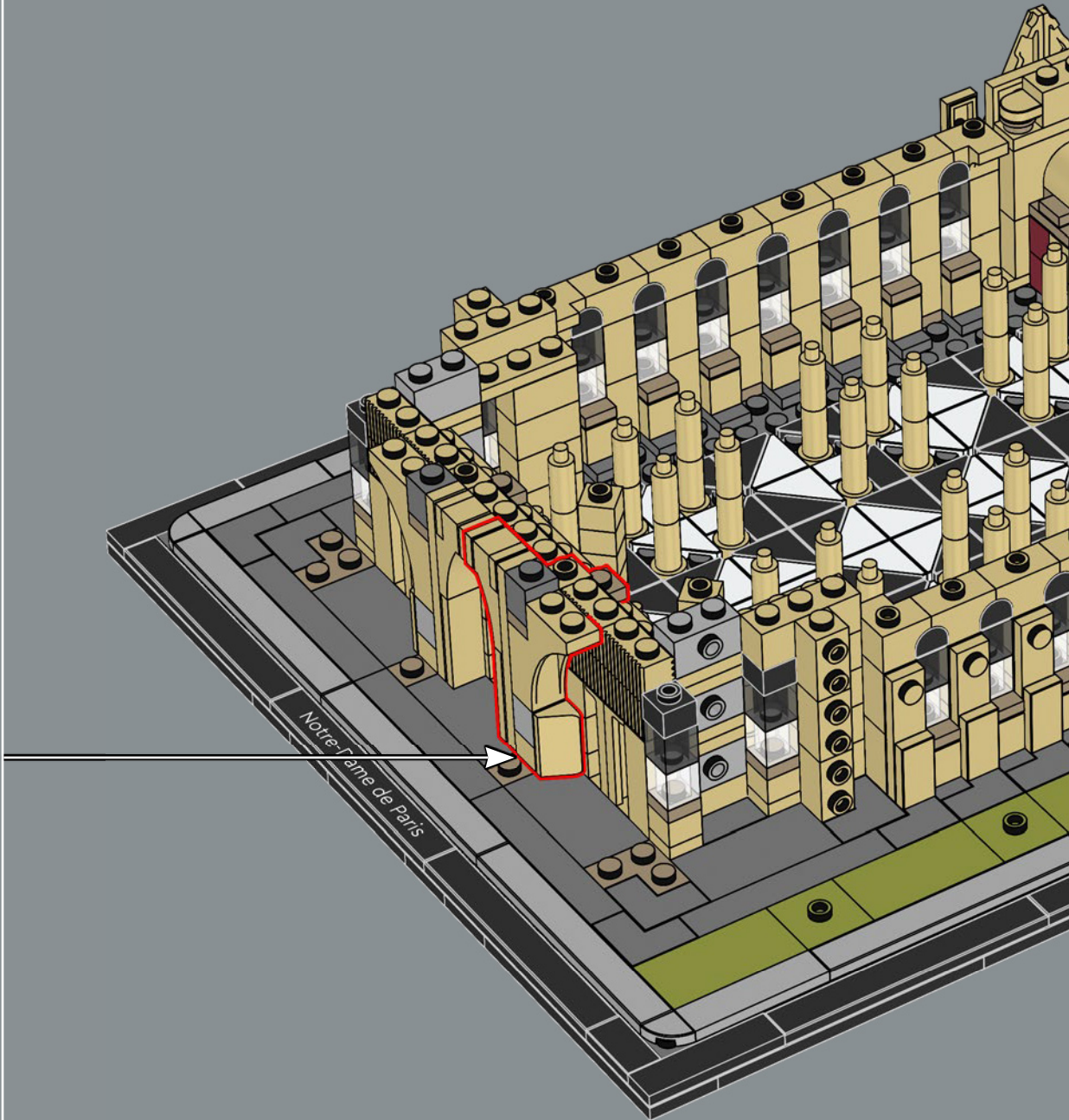
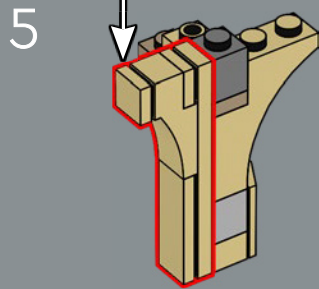
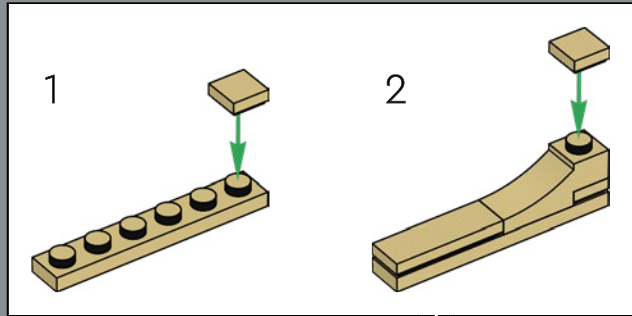

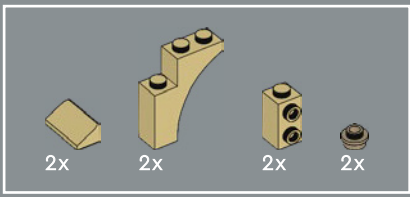

176

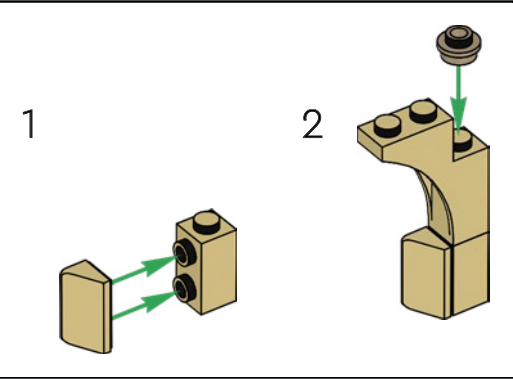
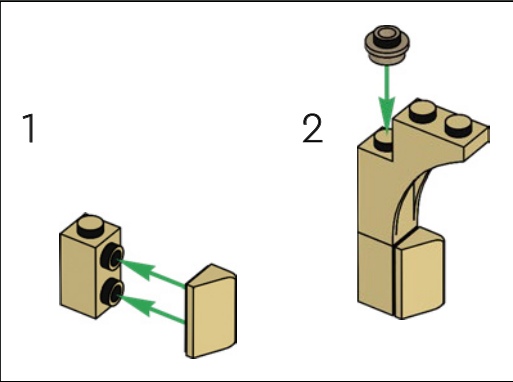



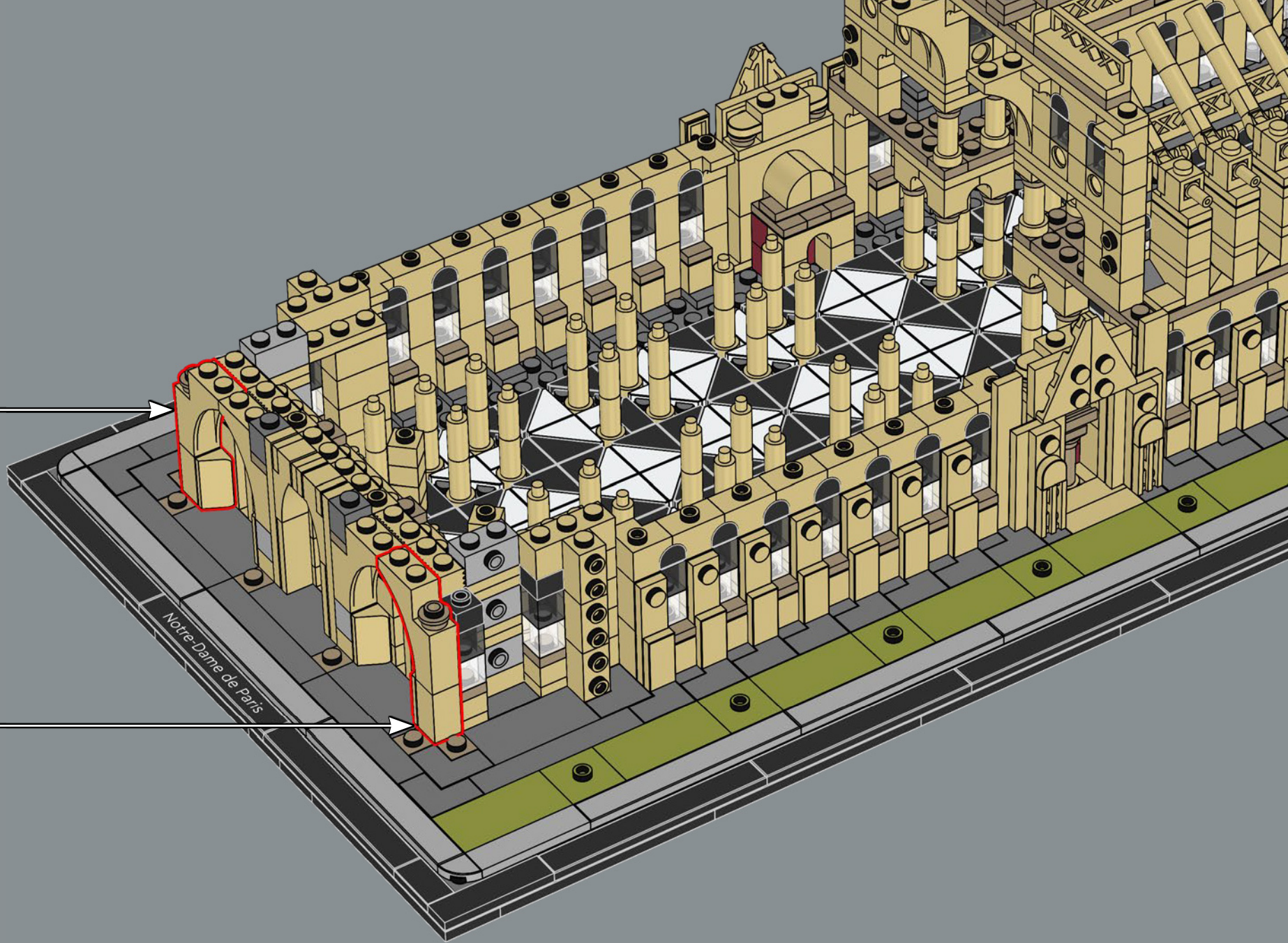

*Notre-Dame de Paris*

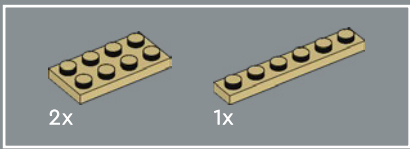

177



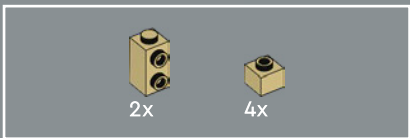

178

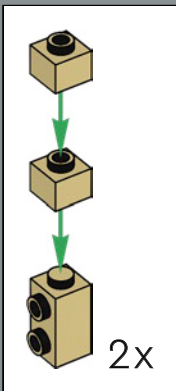

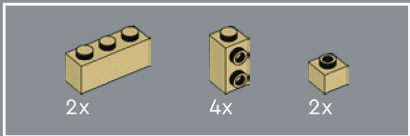

179

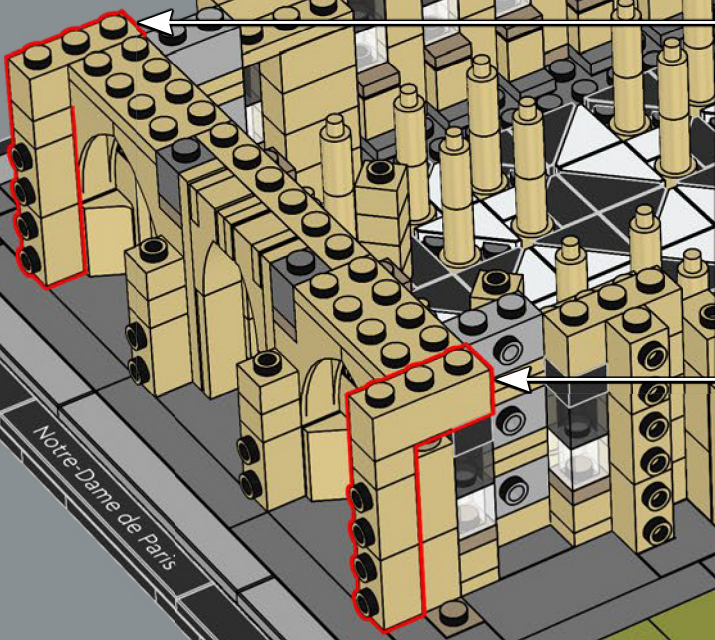
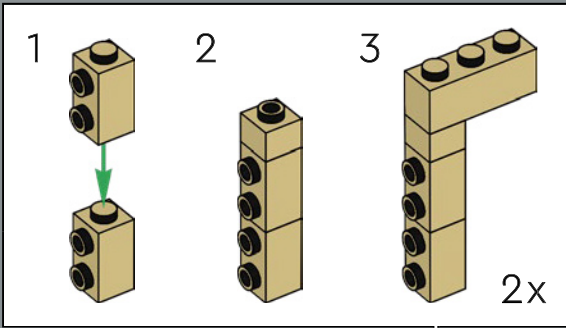

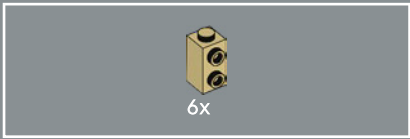

180

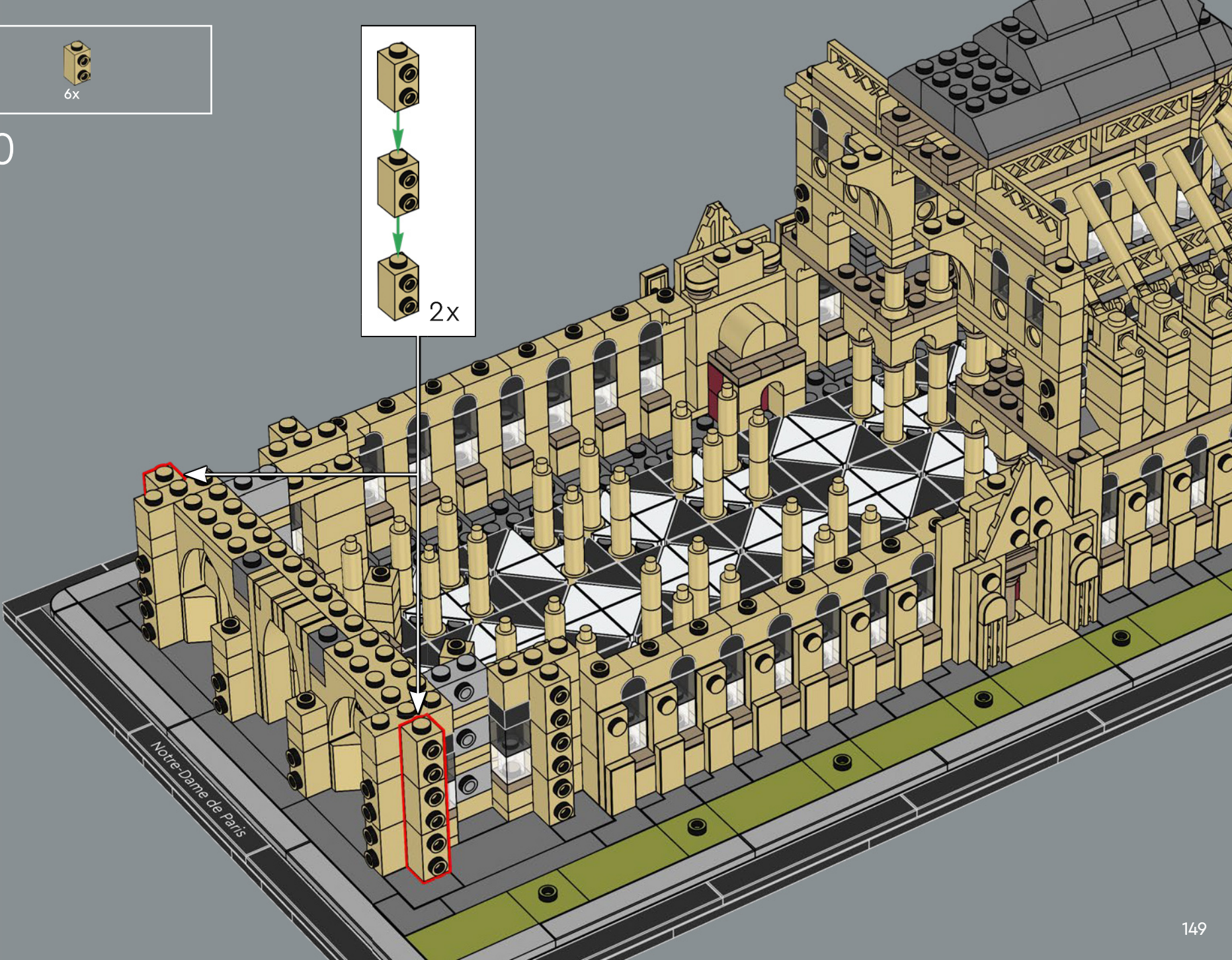
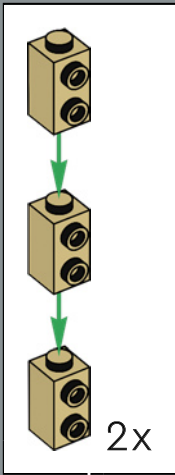

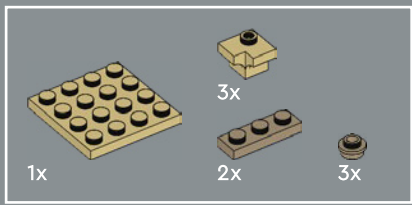

181

1

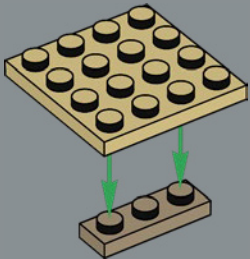

2

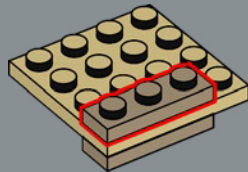

3

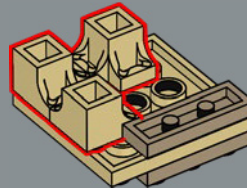

4

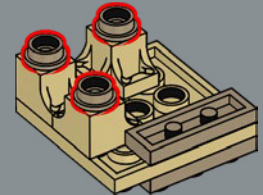



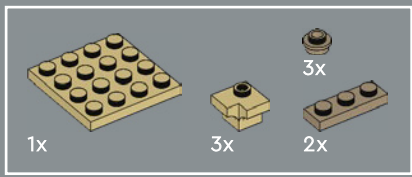

182

1

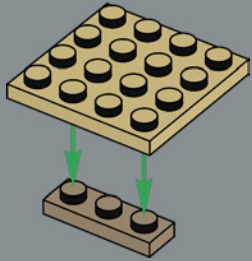

2

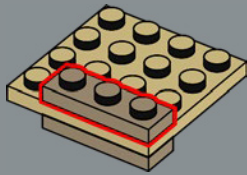

3

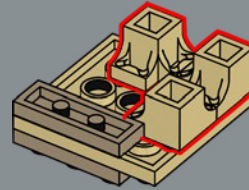

4

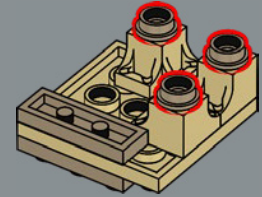





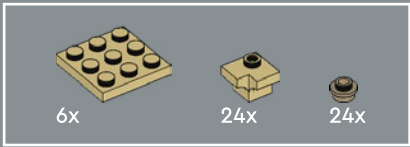

183

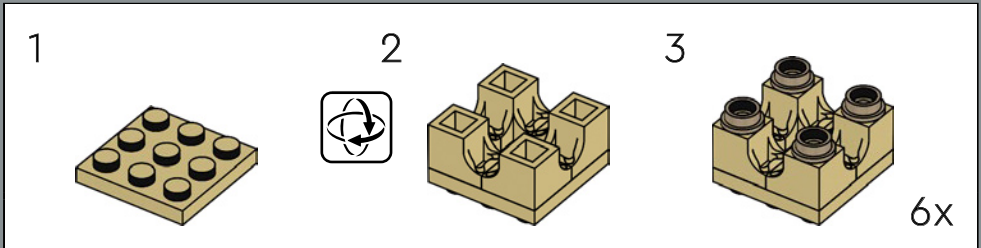

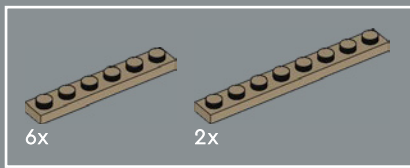

184

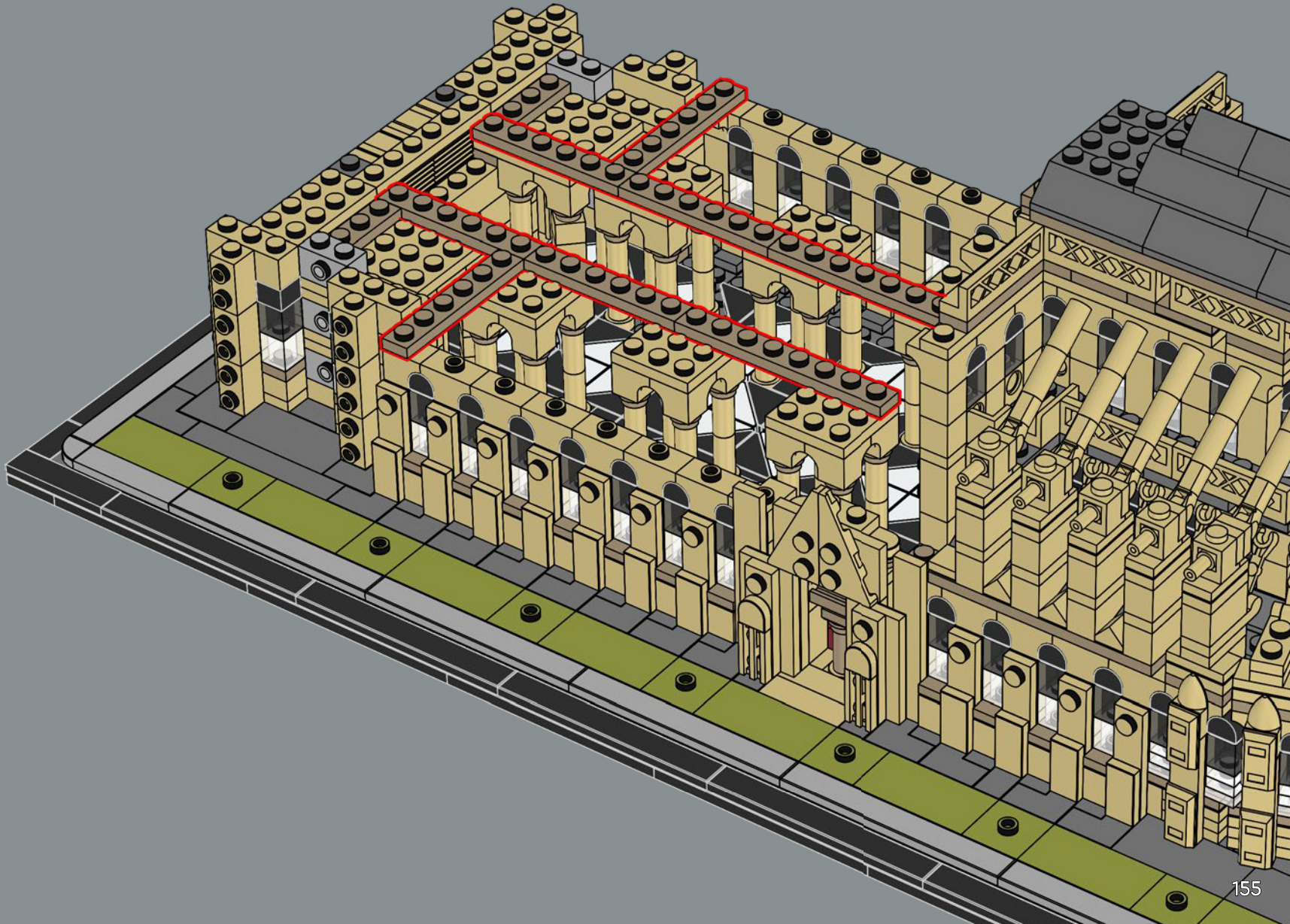



2x 2x 12x

186



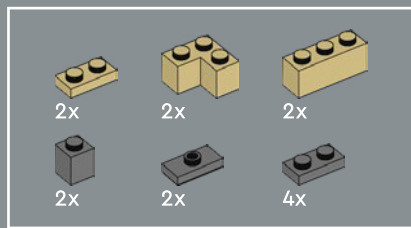

187

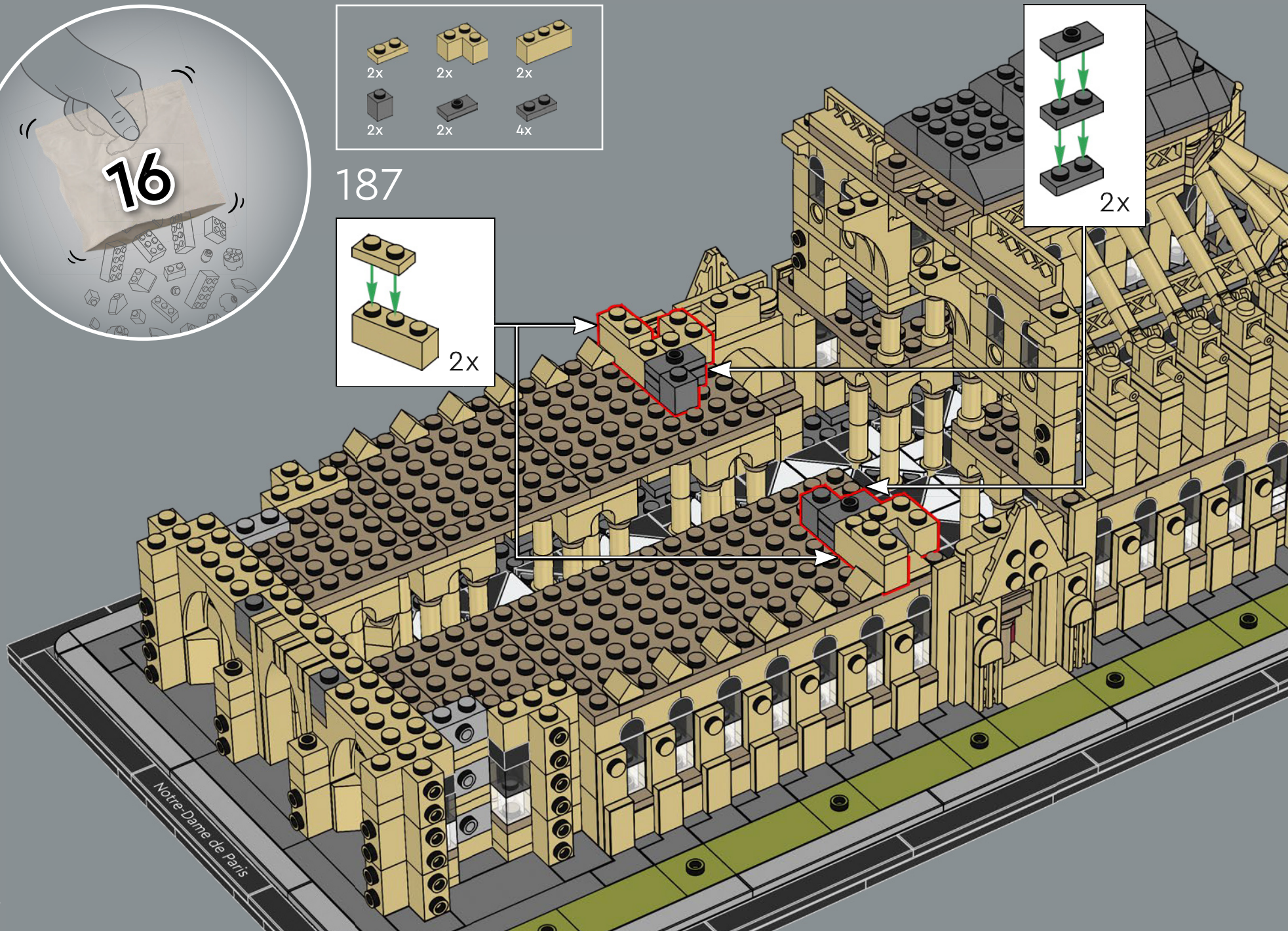
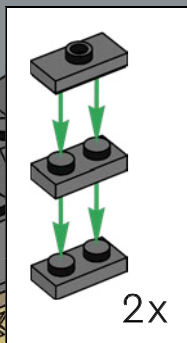
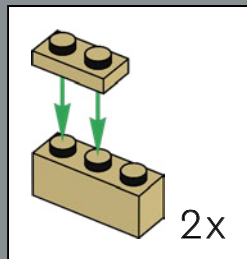

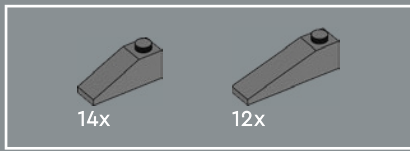

188



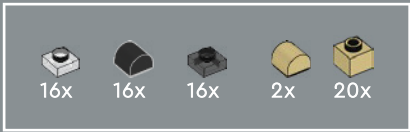

189

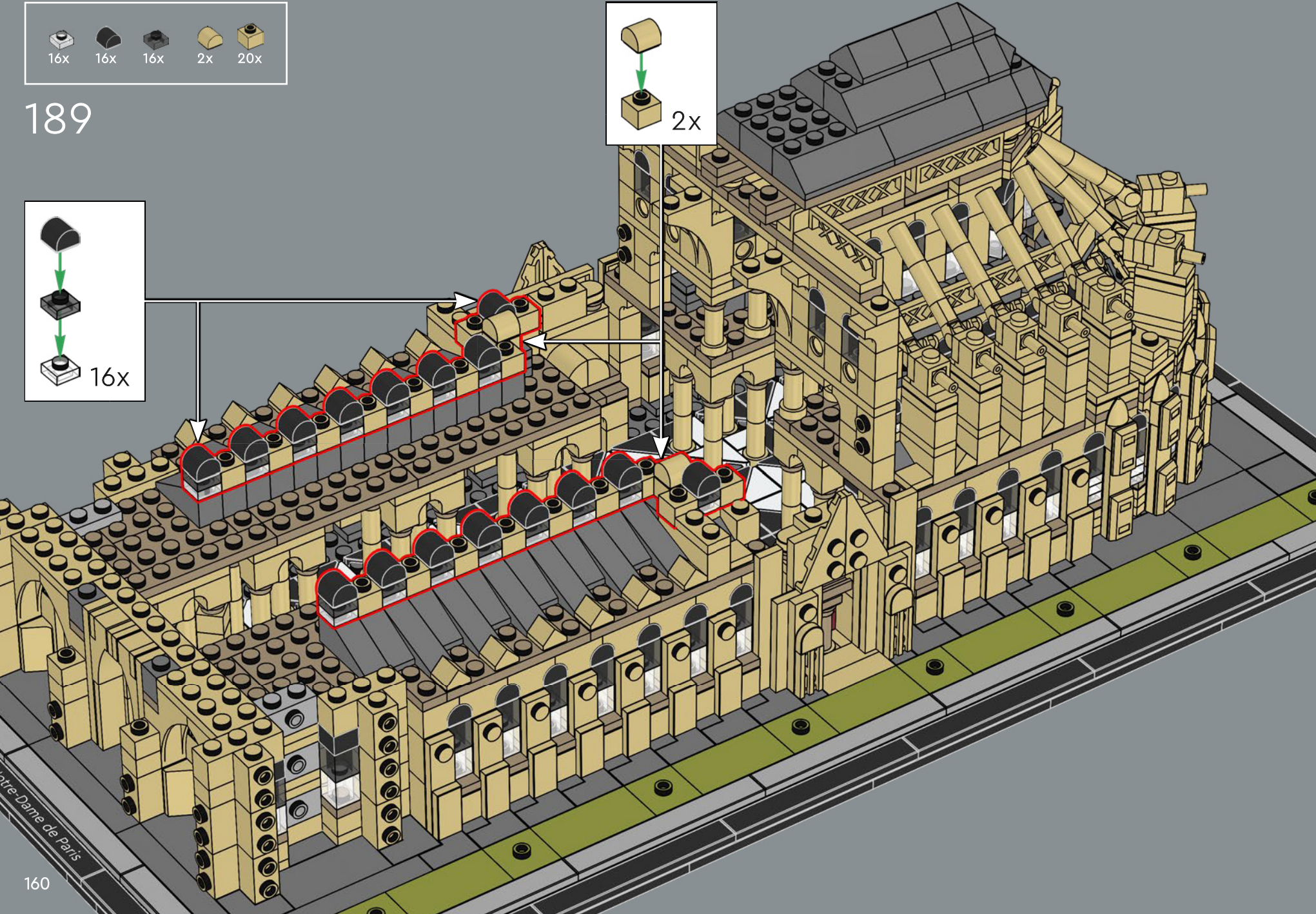
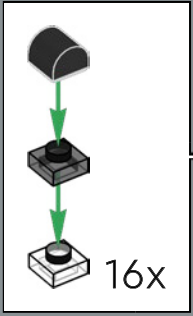
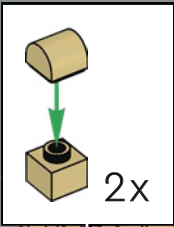



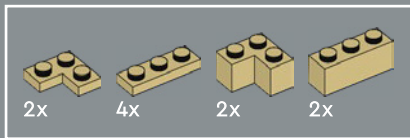

190

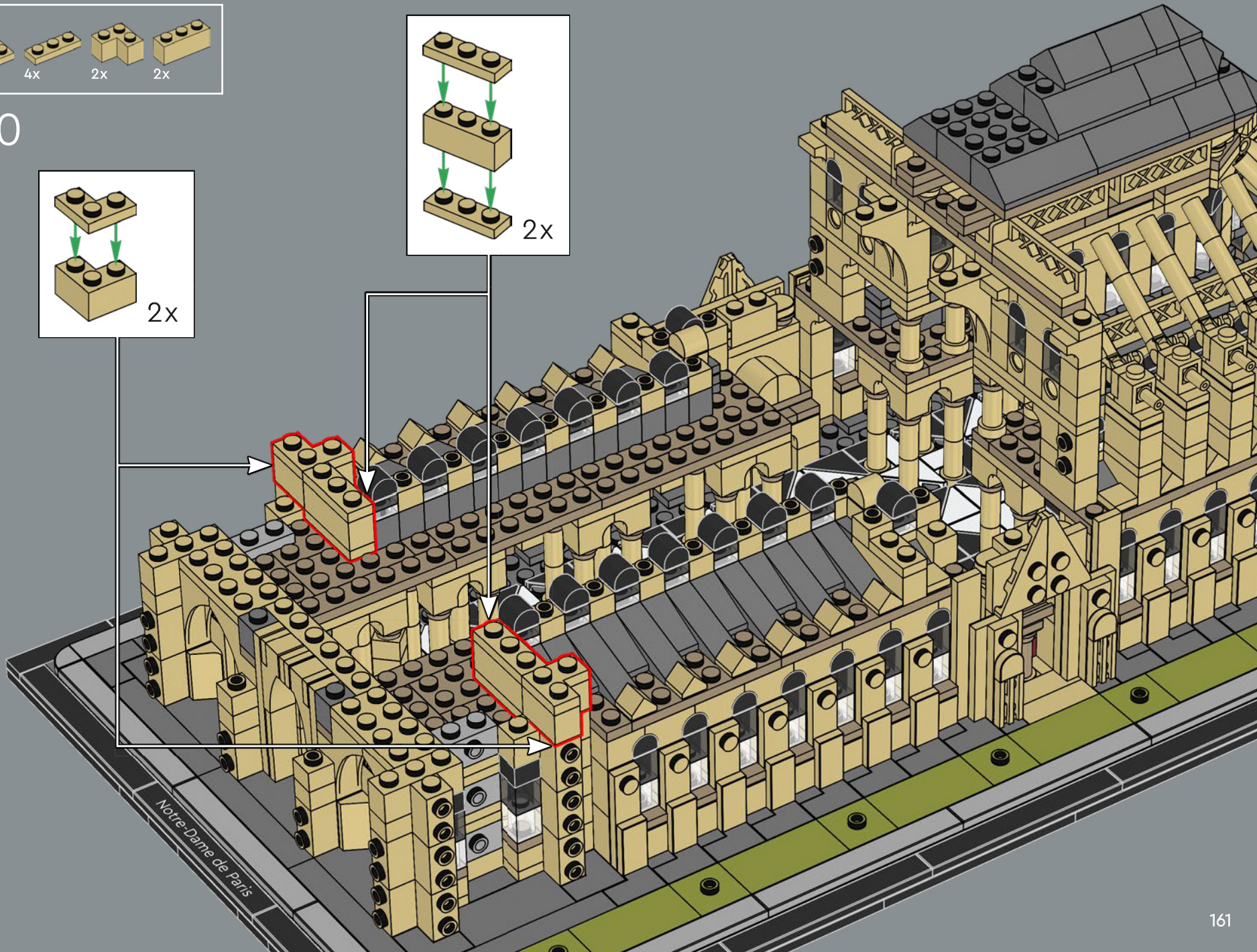
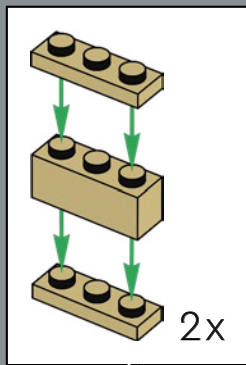
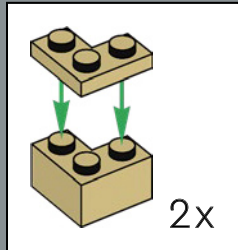



6x

191

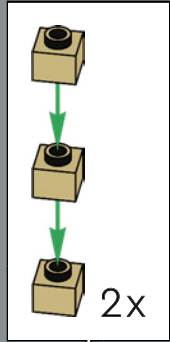

2x



*Notre-Dame de Paris*

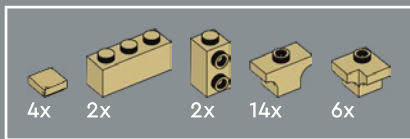

192

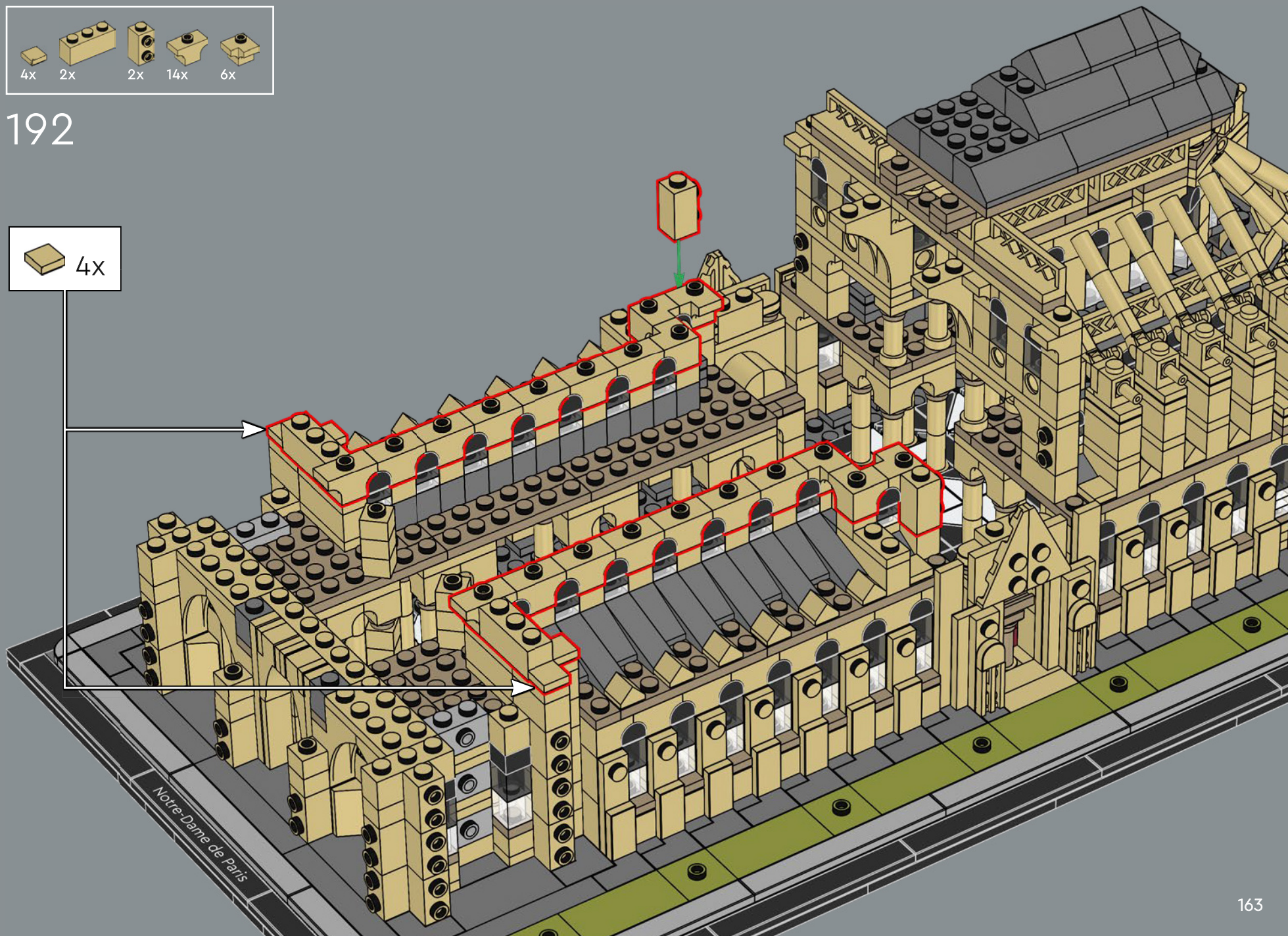

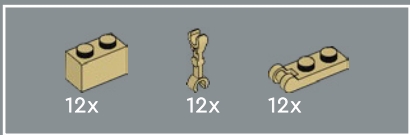

193

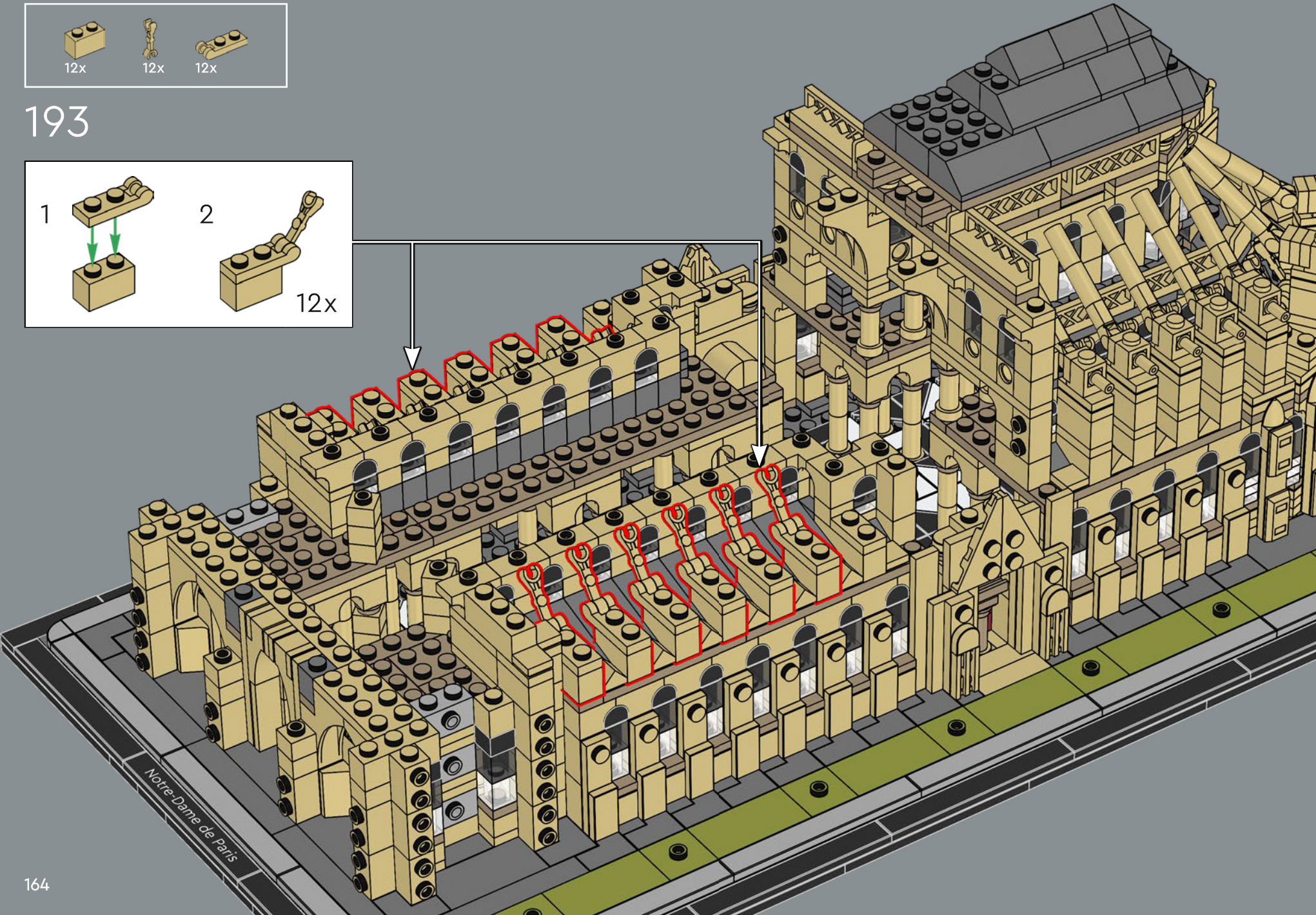
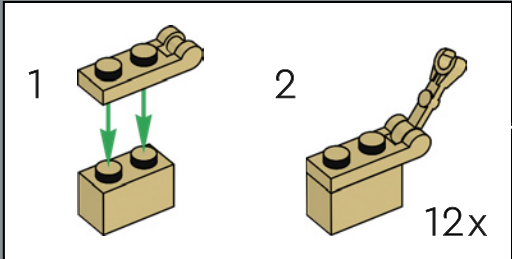



194

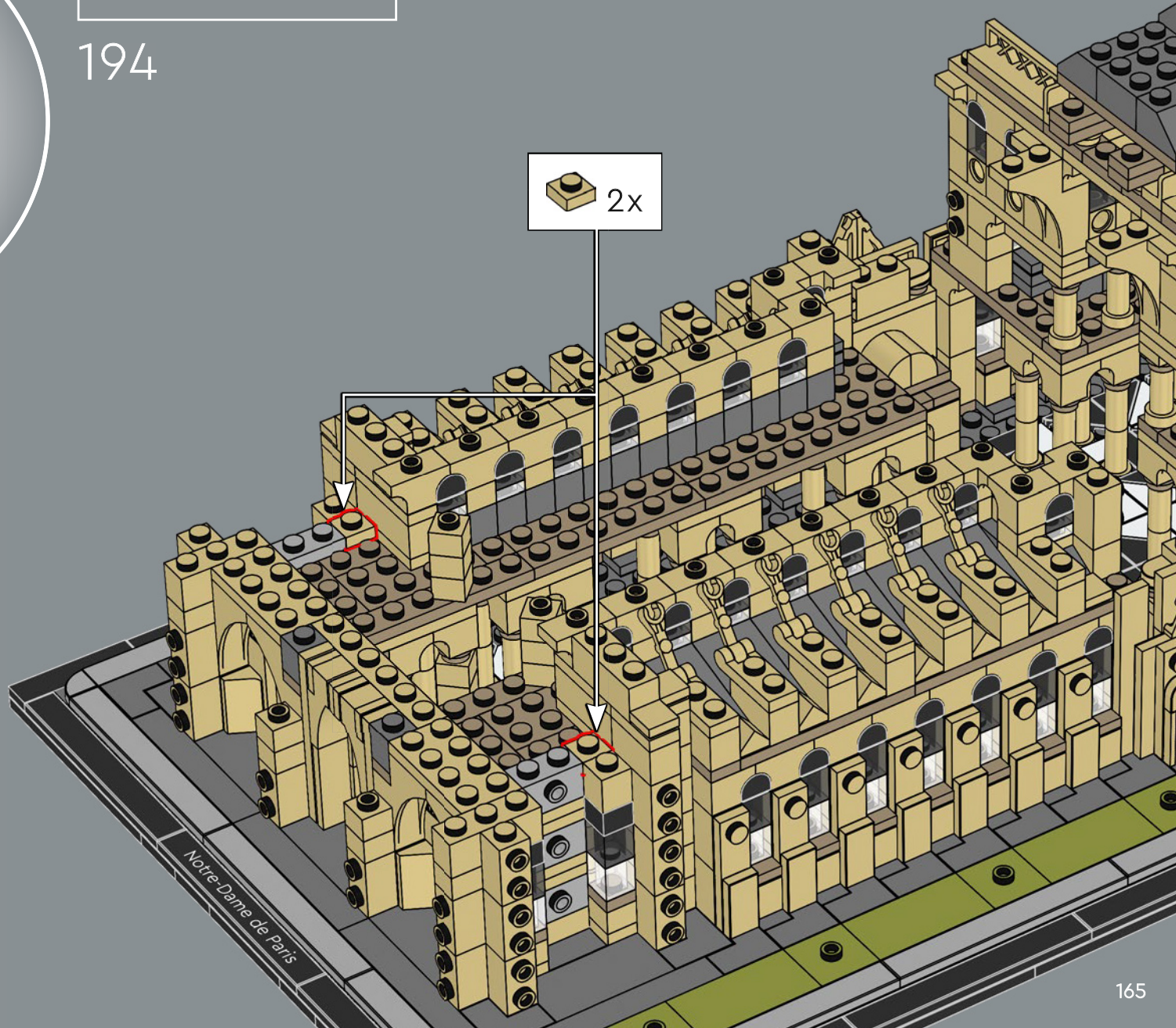

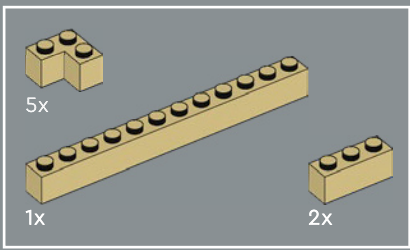

195

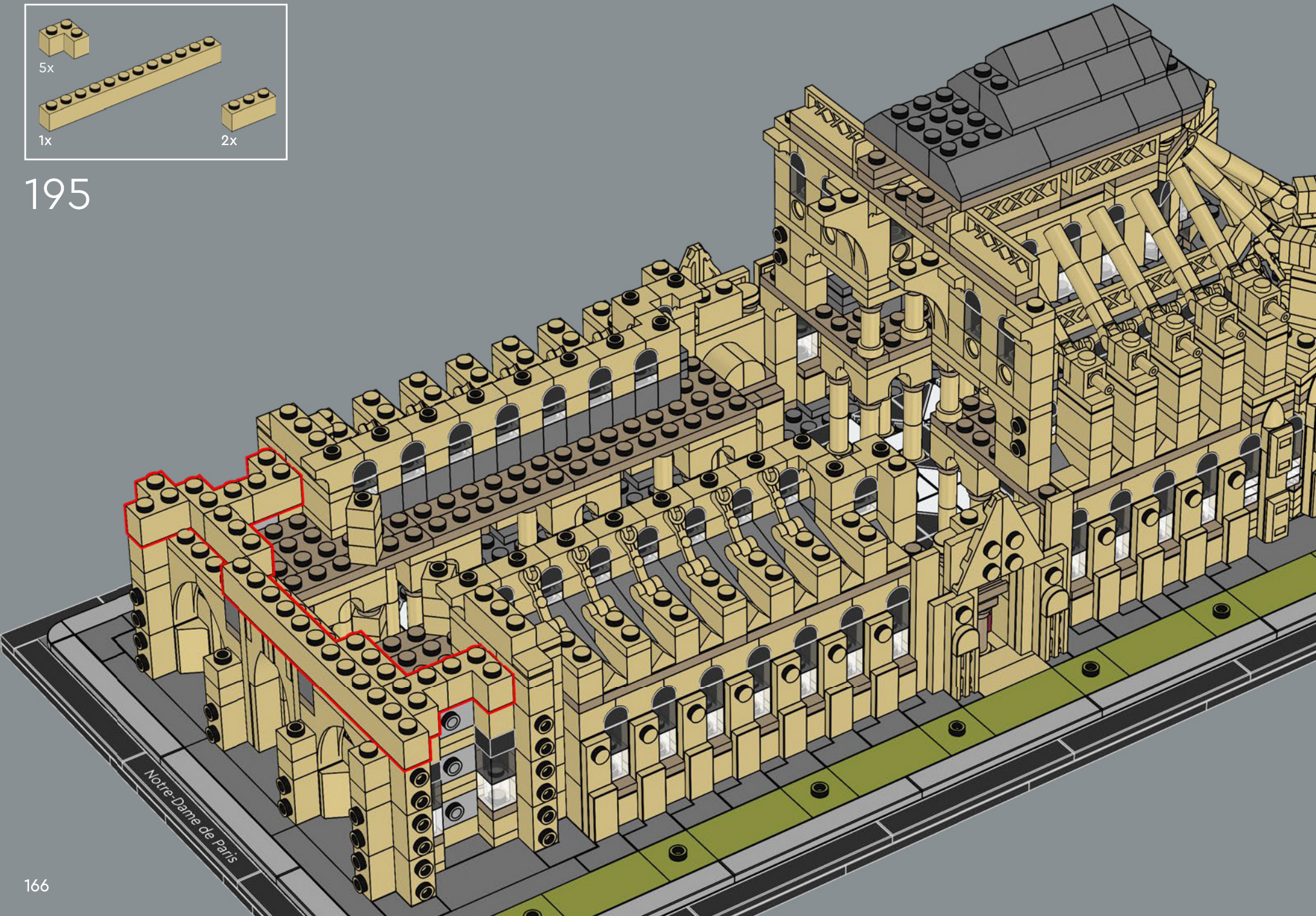

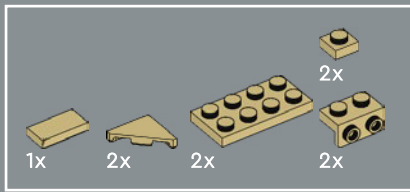

196

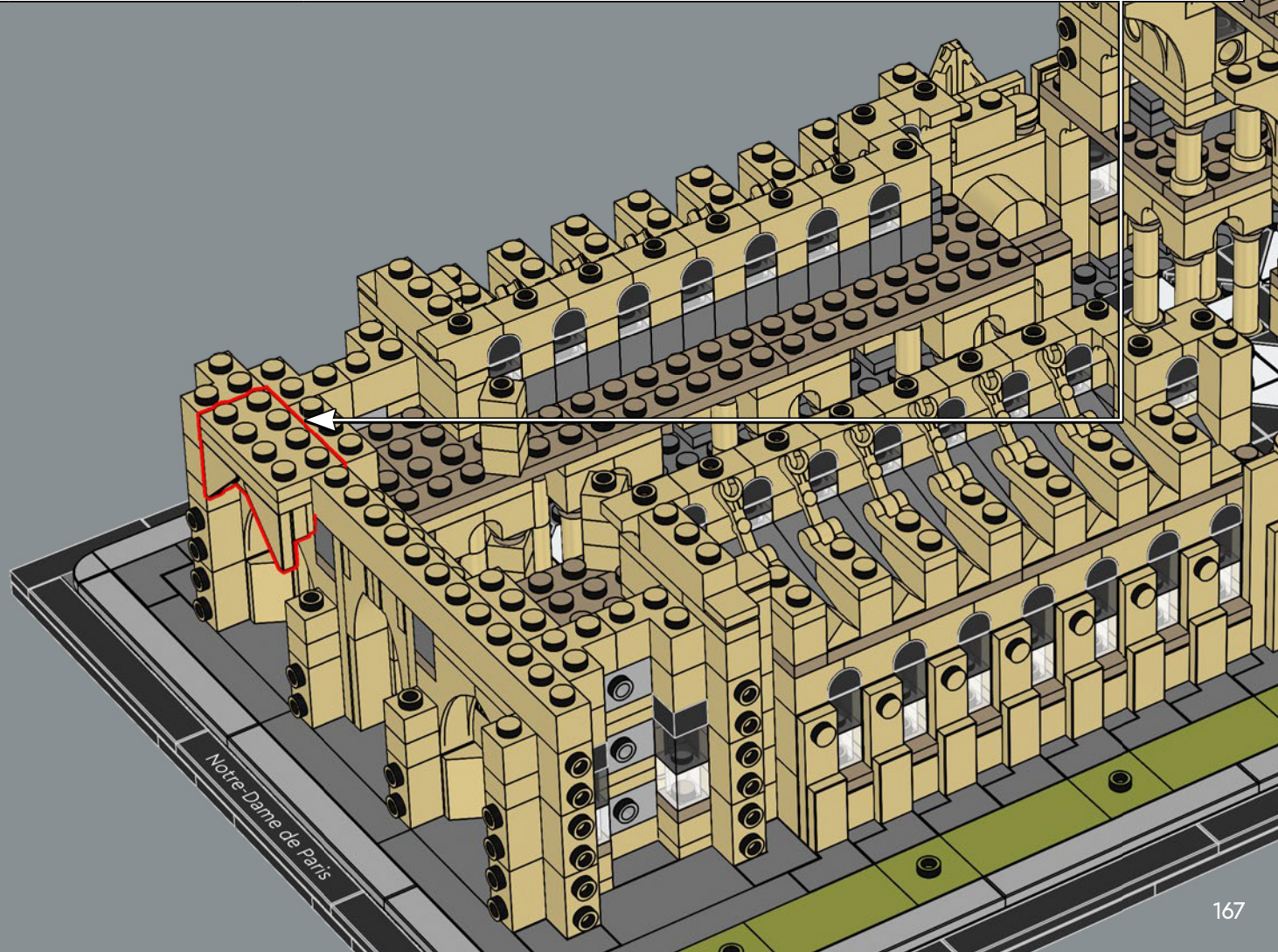
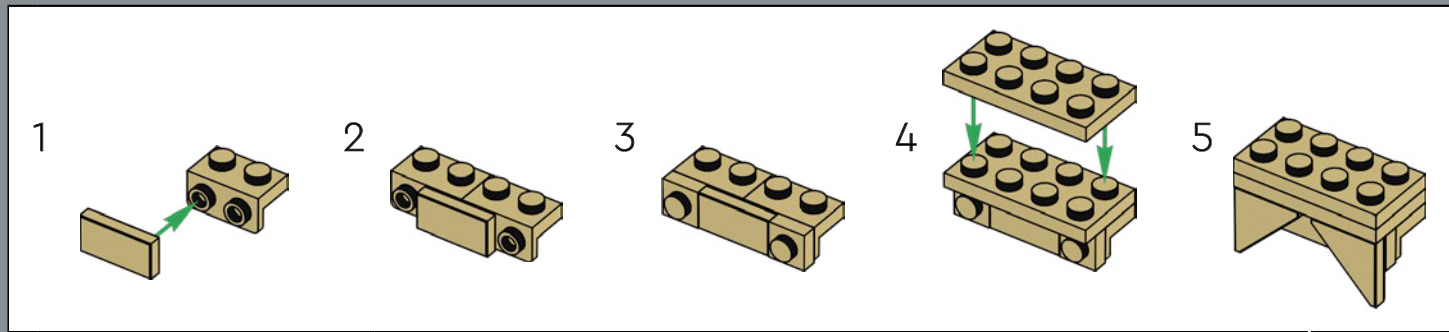

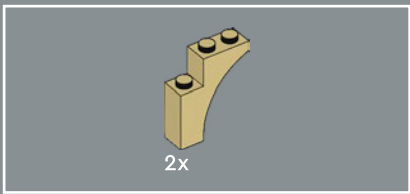

197

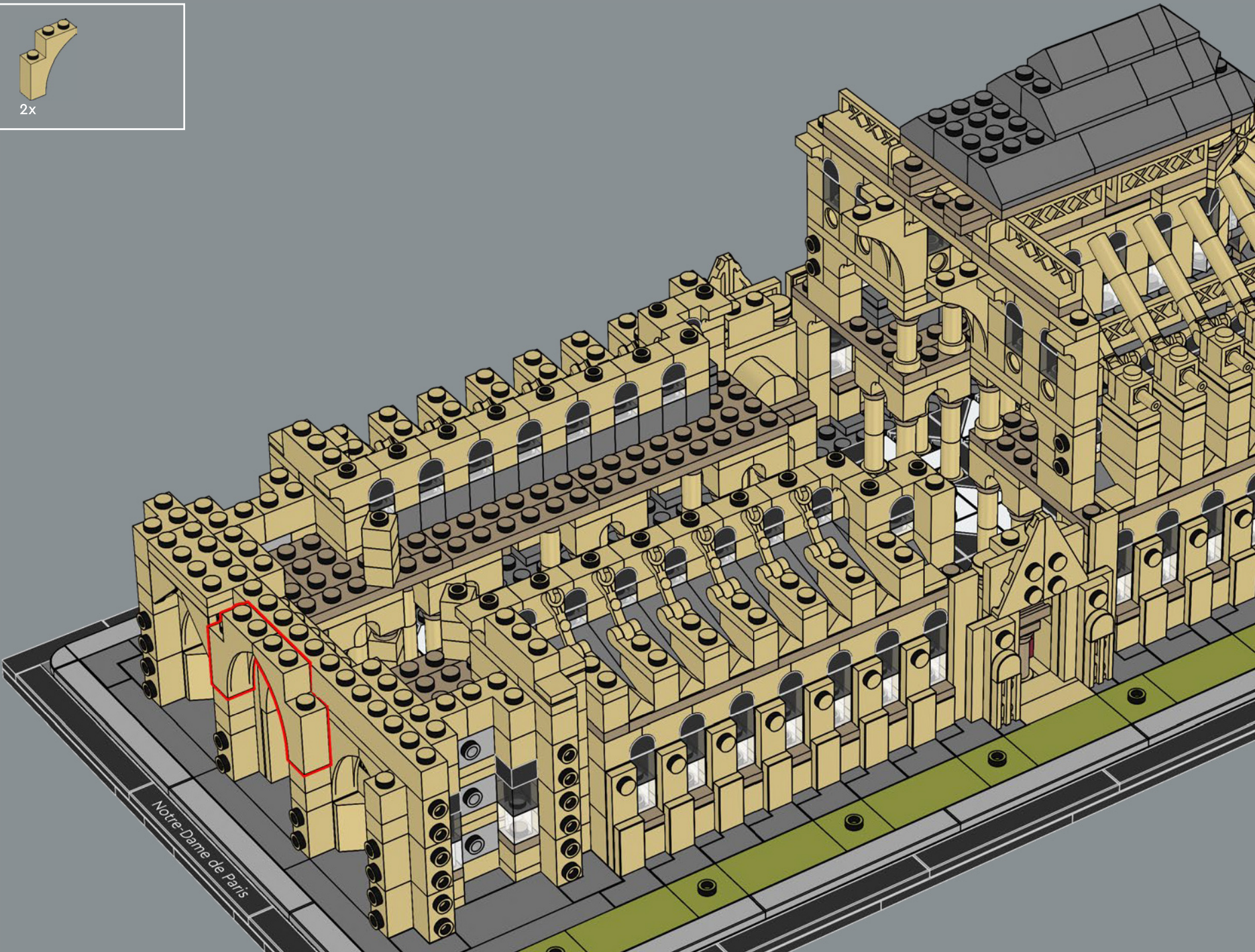



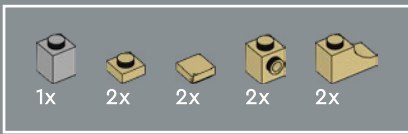

198

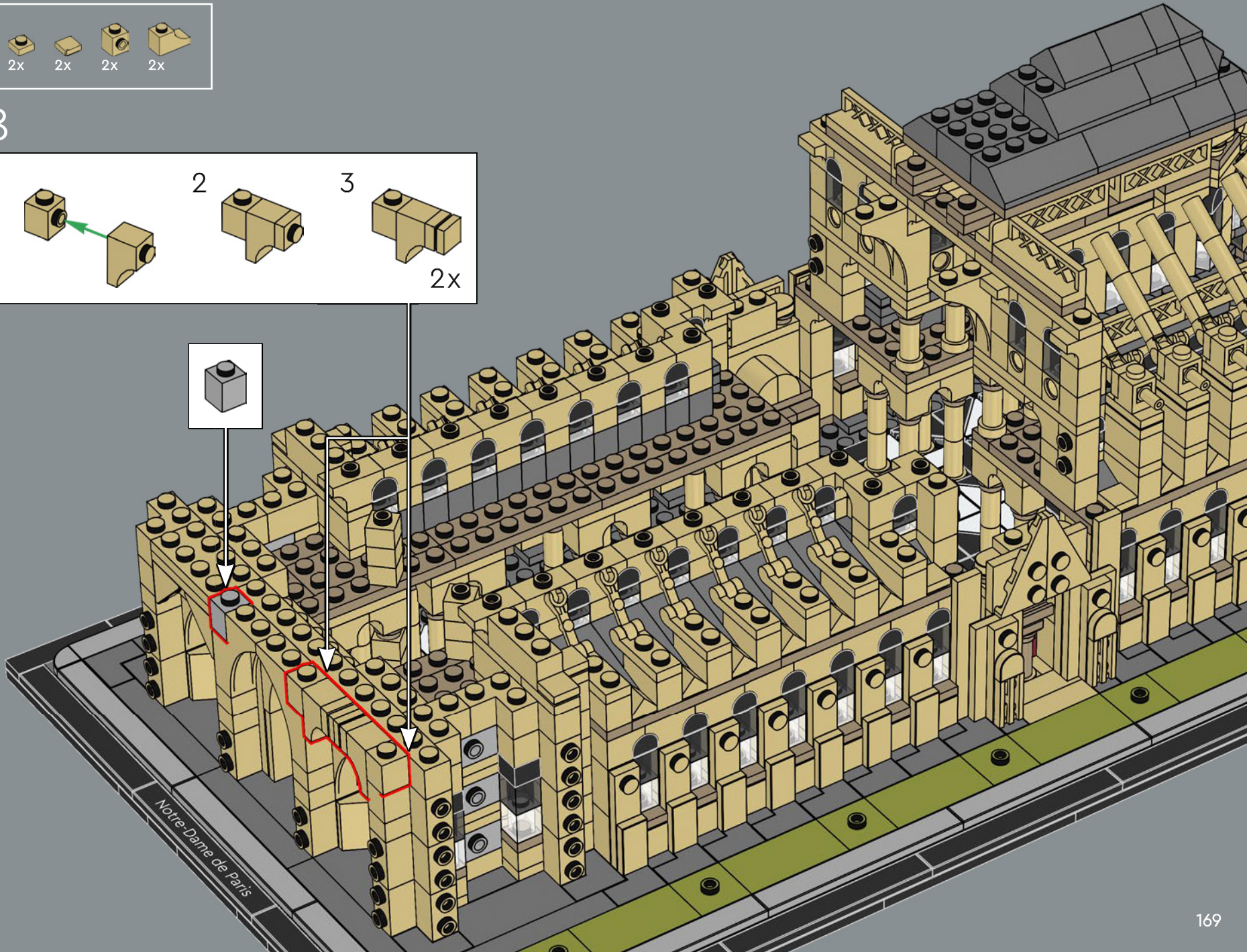
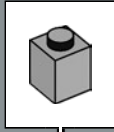
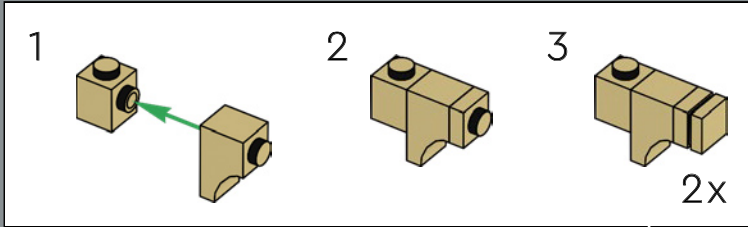

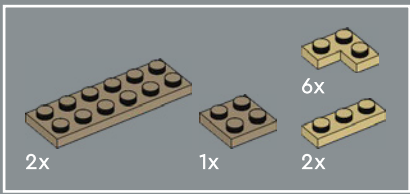

199



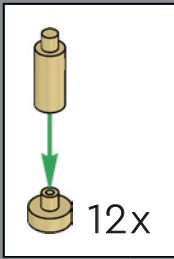

200

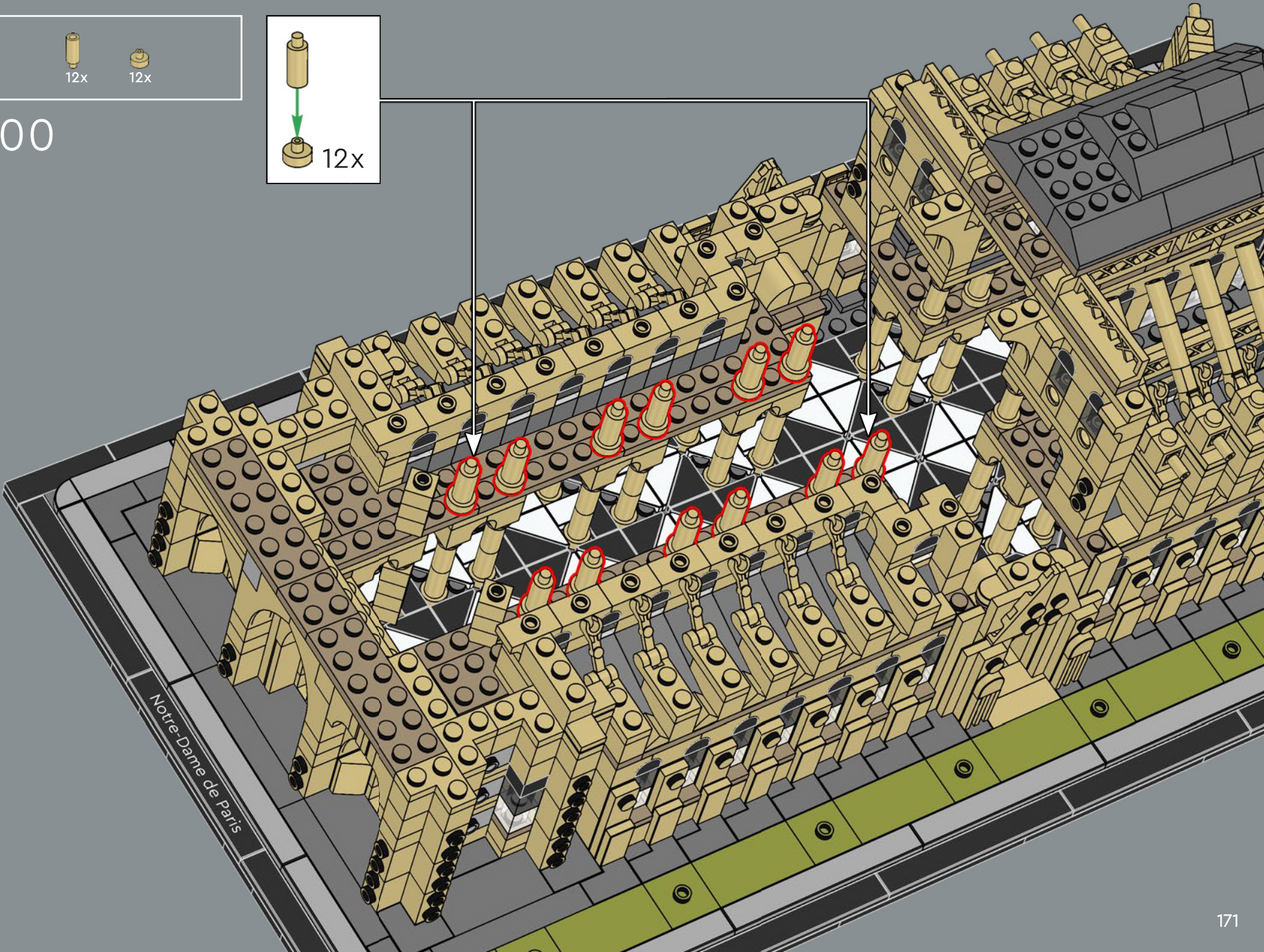

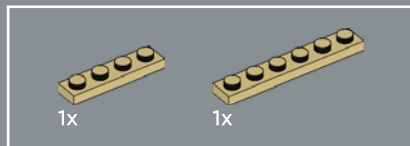
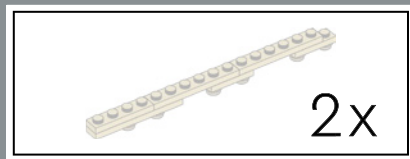

201

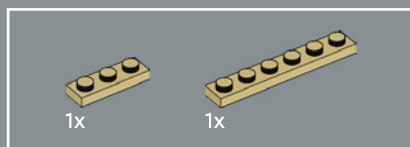
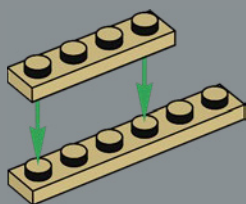

202

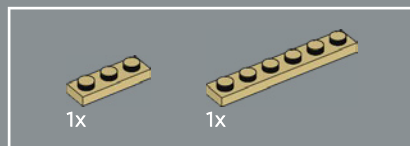
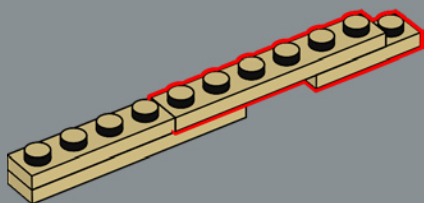

203

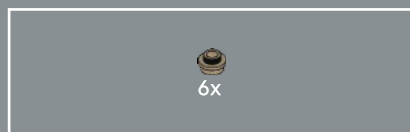
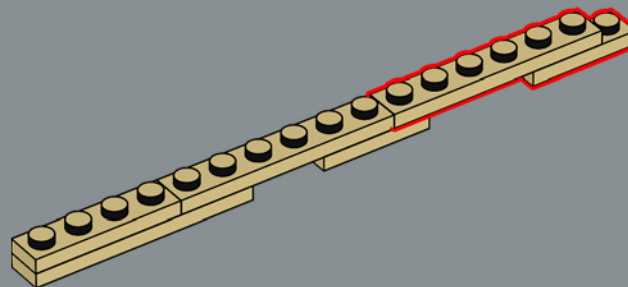

204

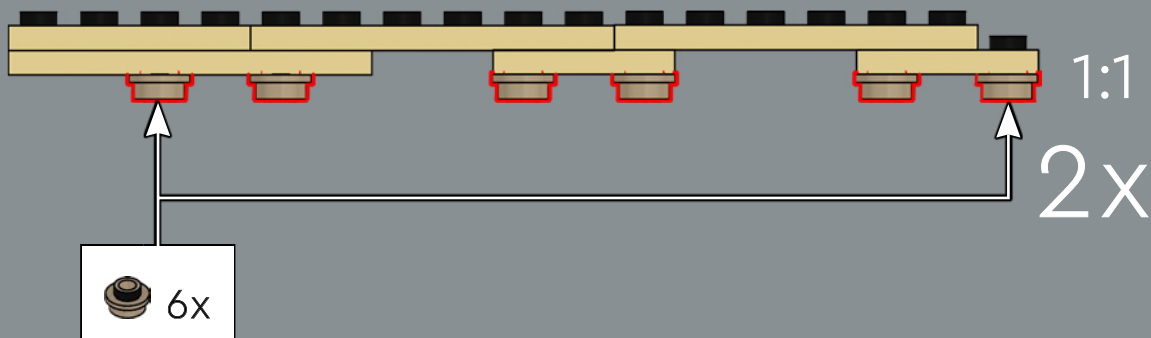

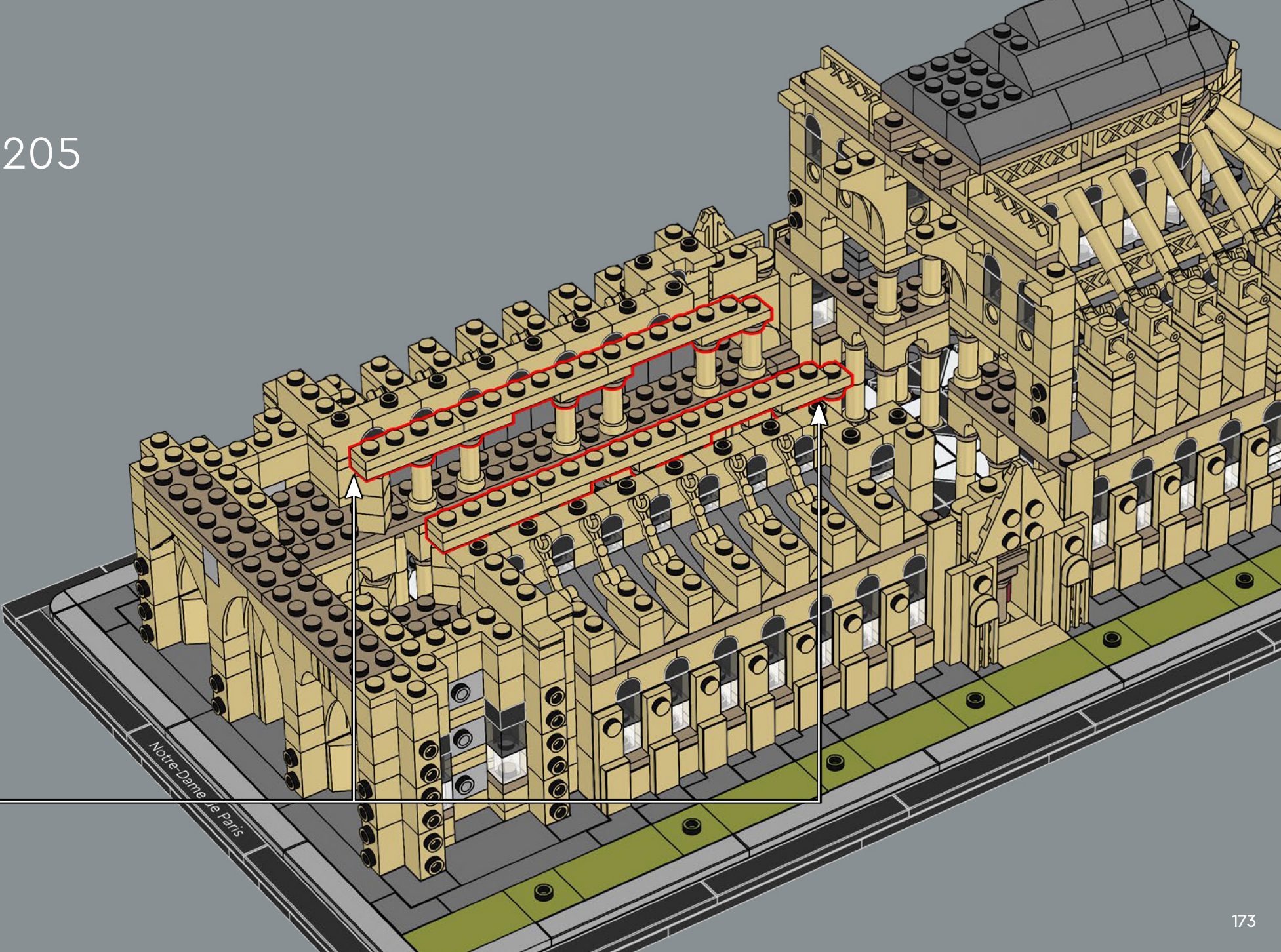

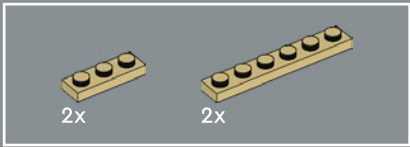

206

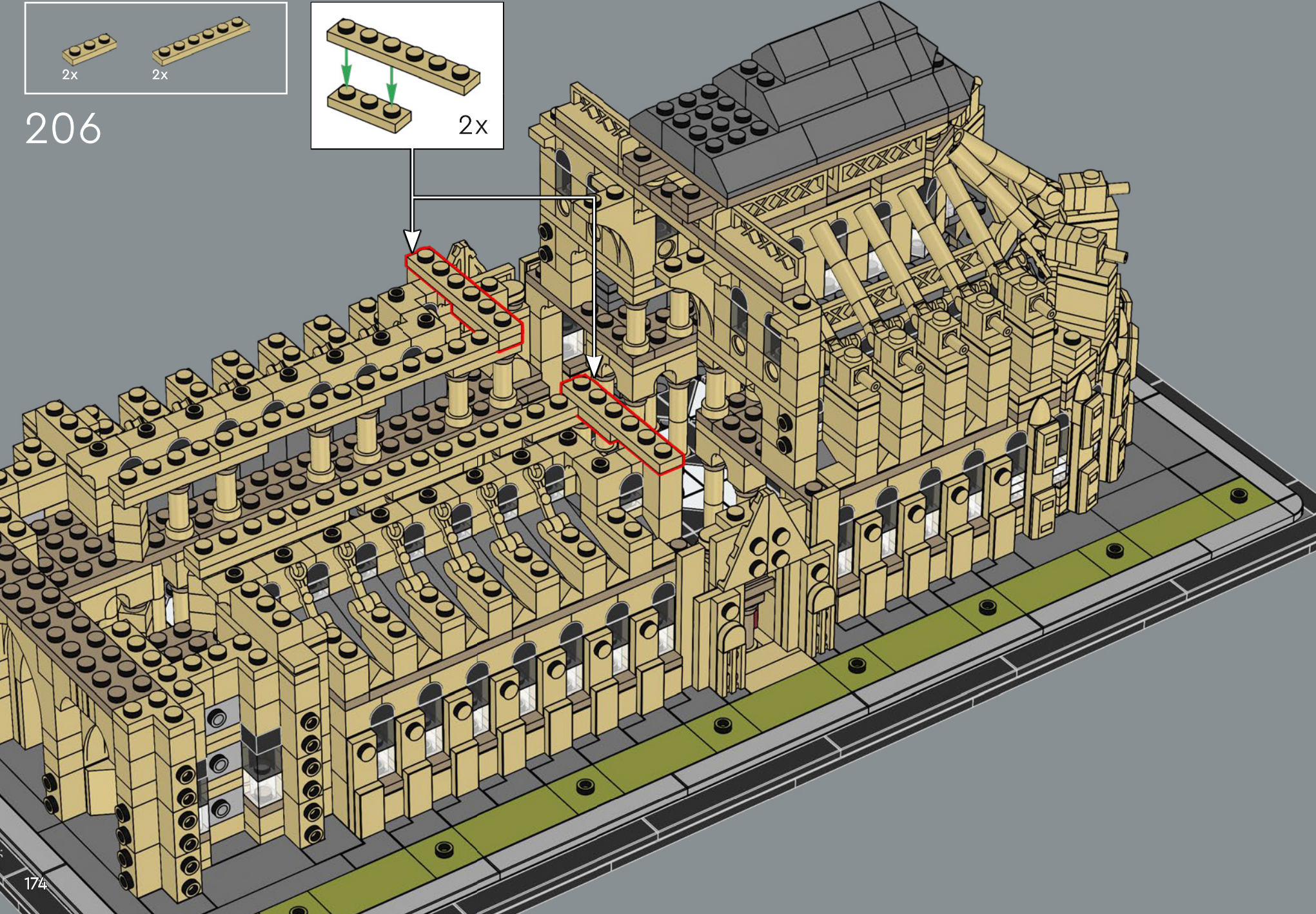
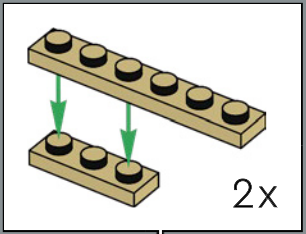

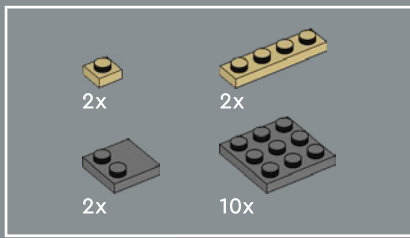

207

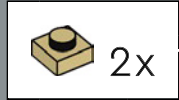

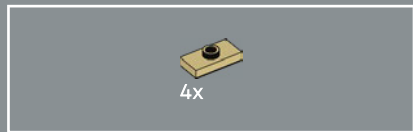

208

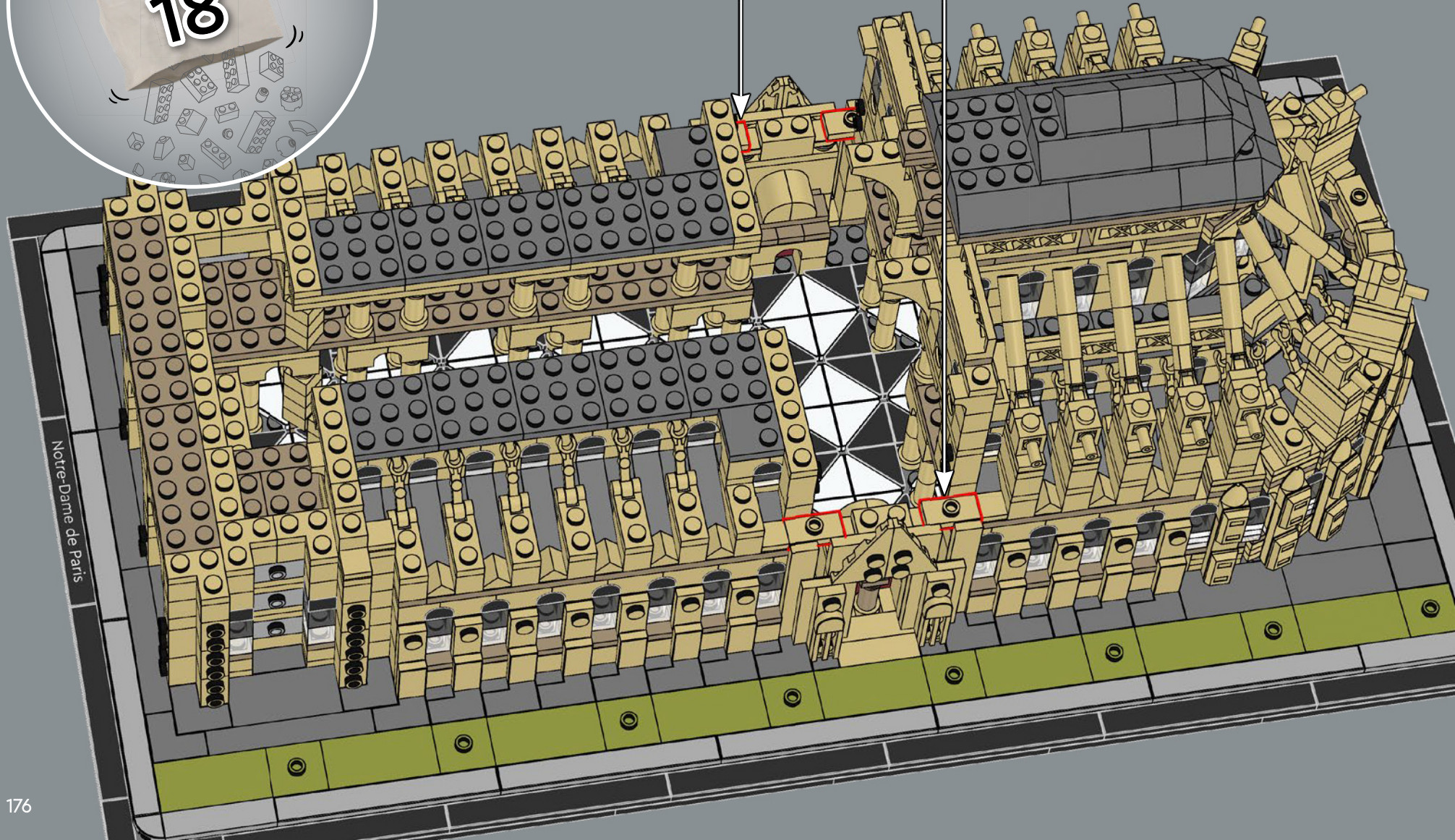



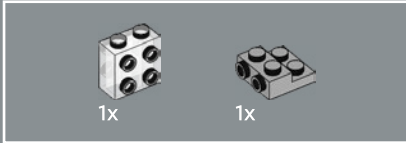
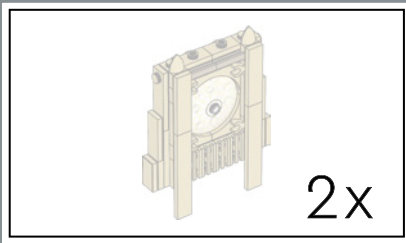

209

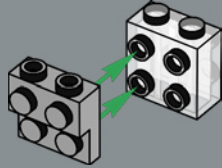

210

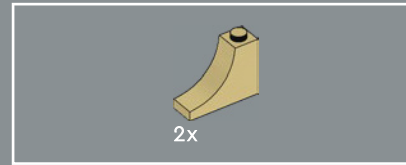
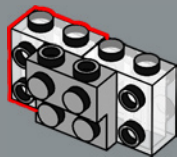

211

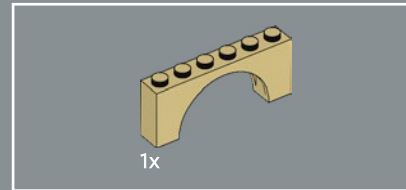
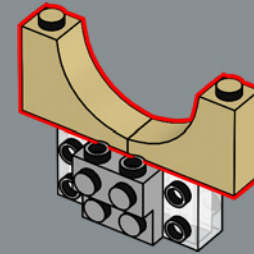

212

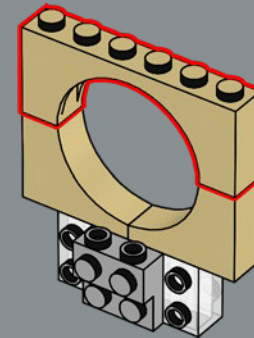

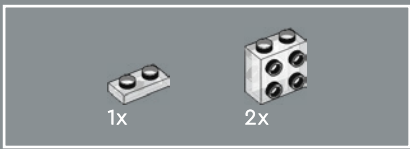

213

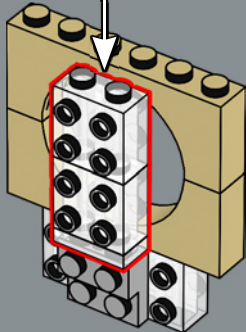
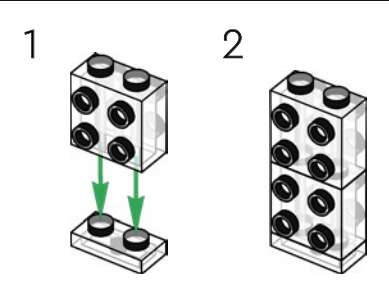

214

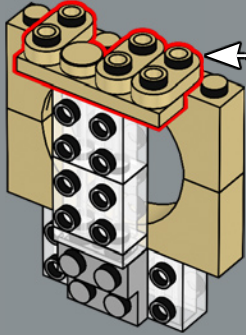
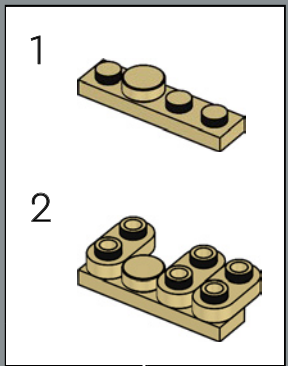

215

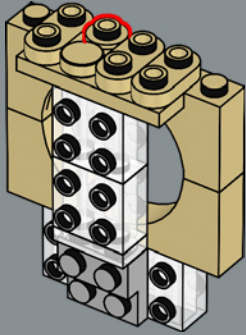

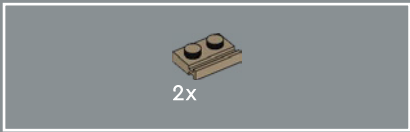

216

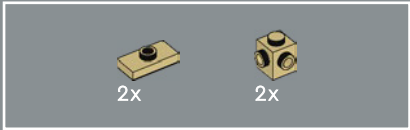
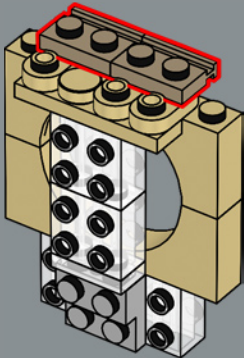

217

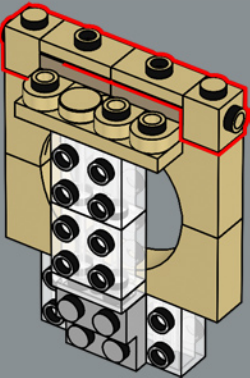

218

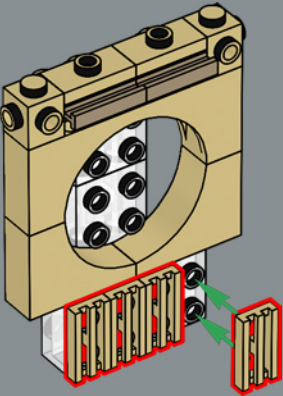

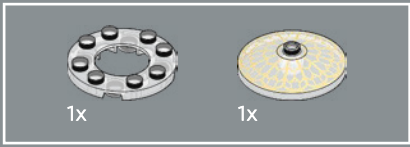

219

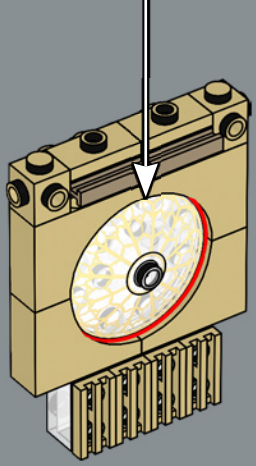
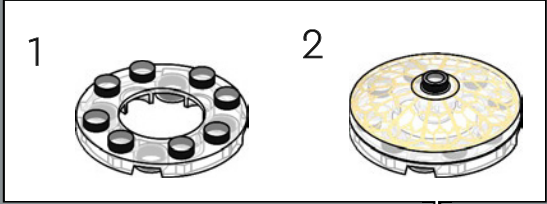

220

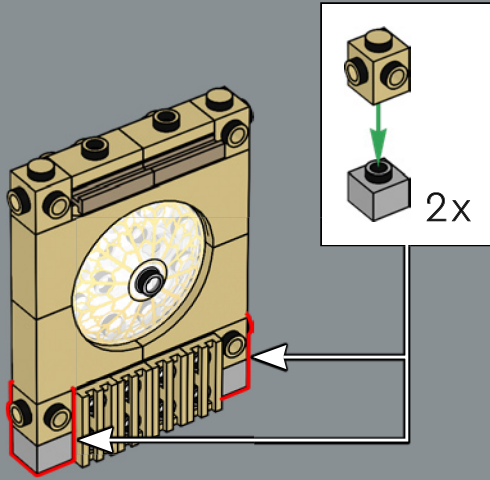

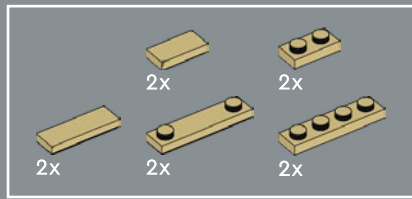

221

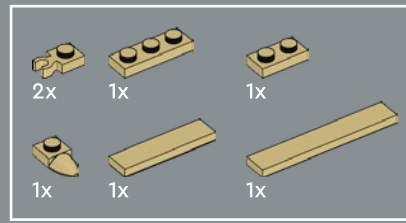
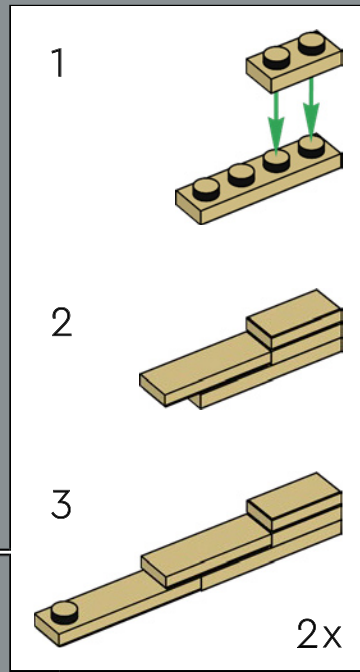
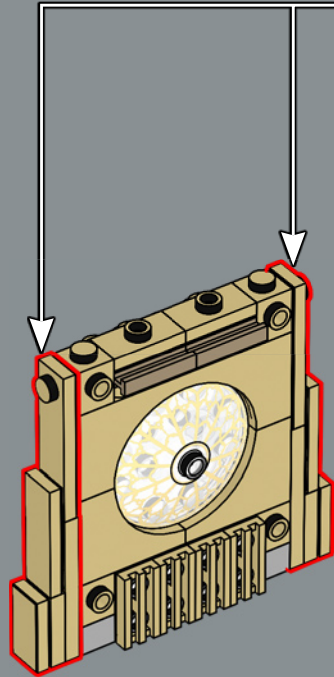

222

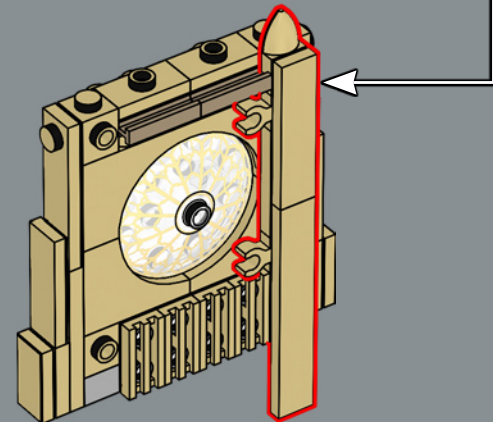
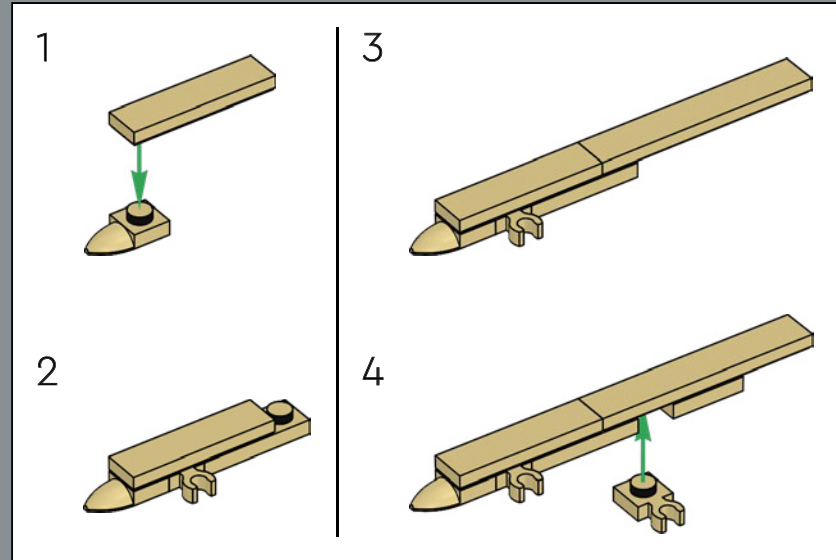

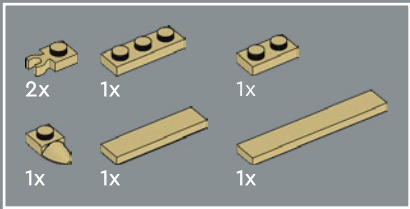

223

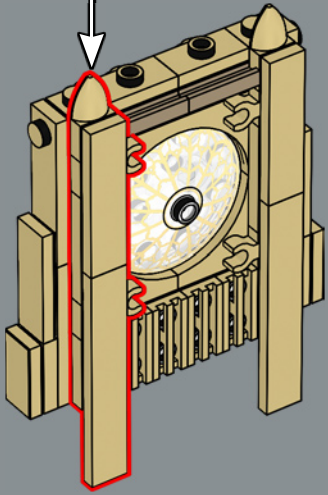
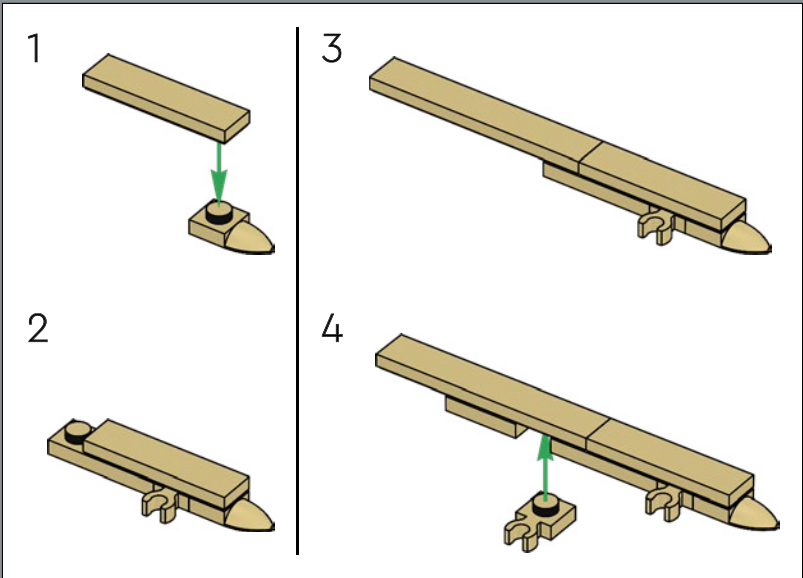

224

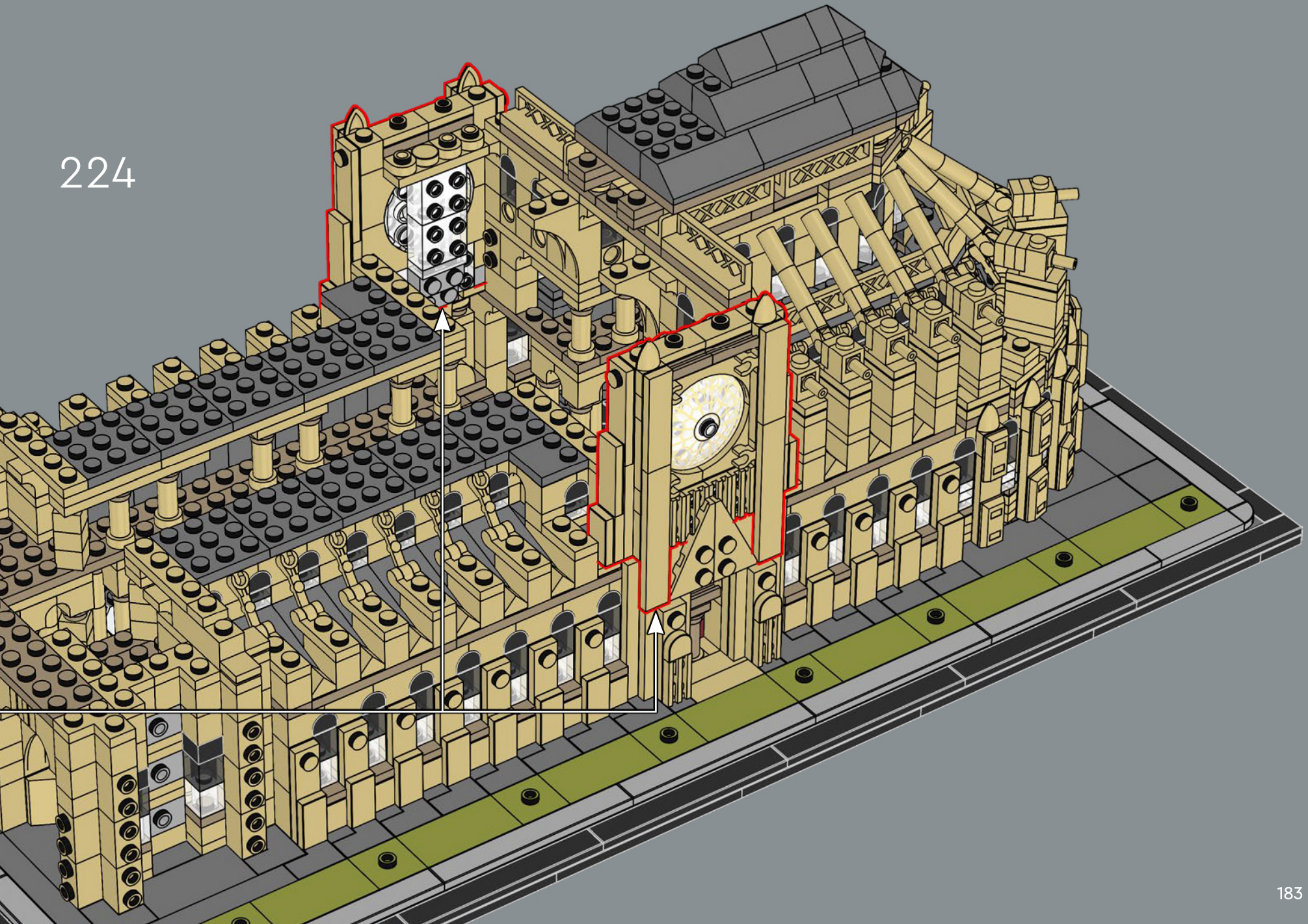

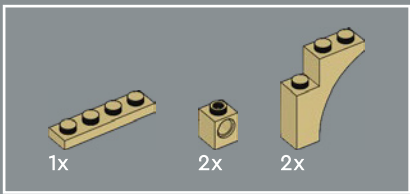

225

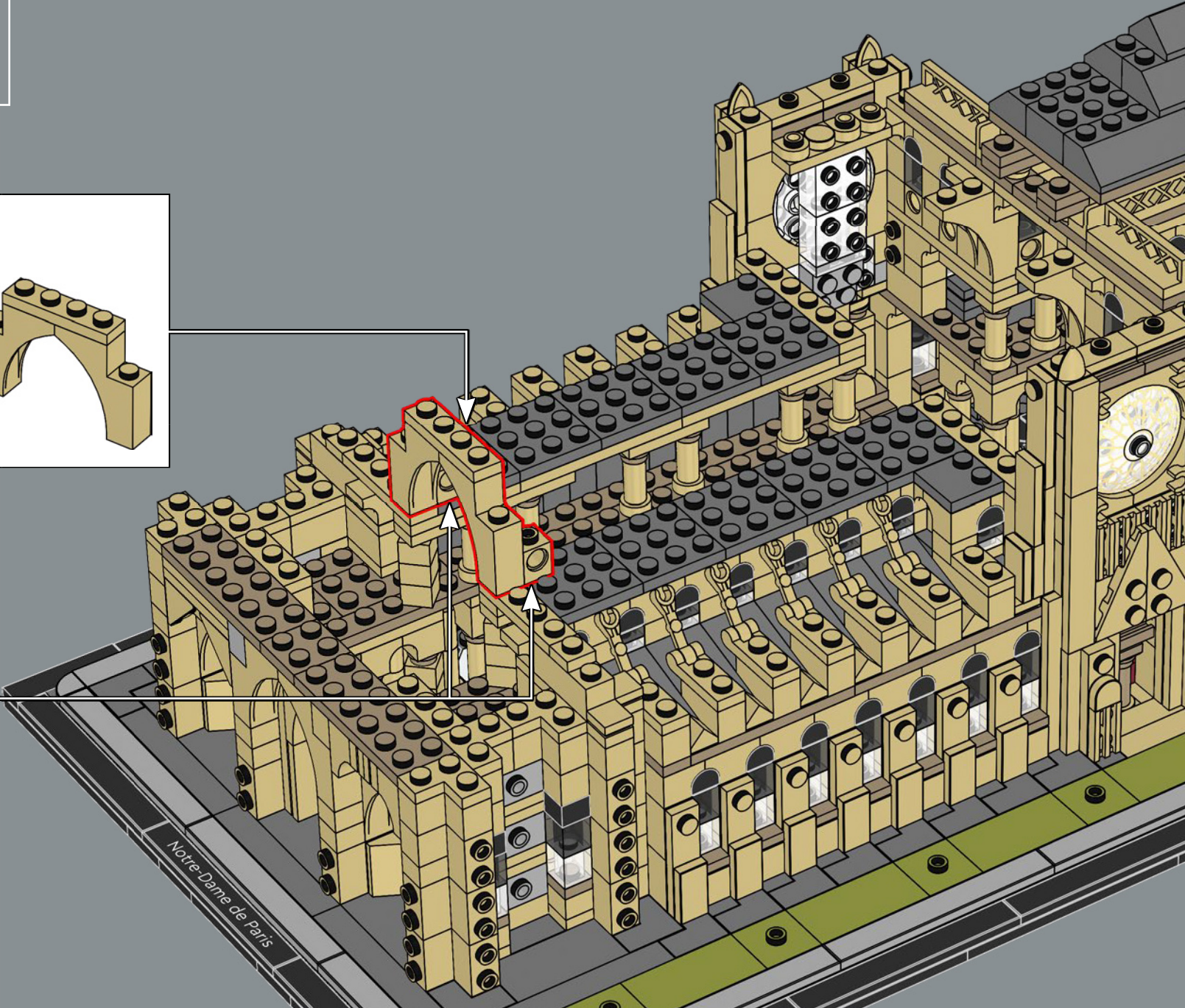
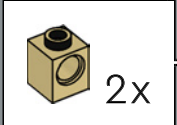
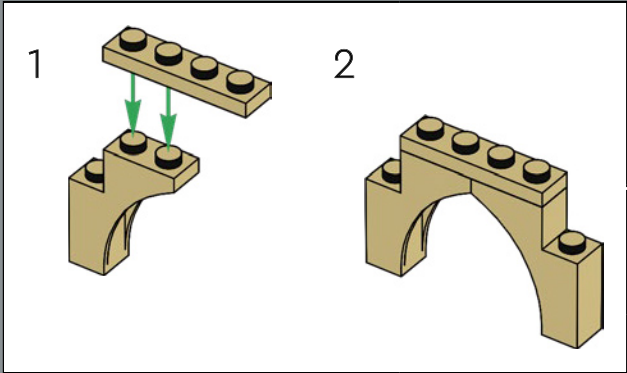



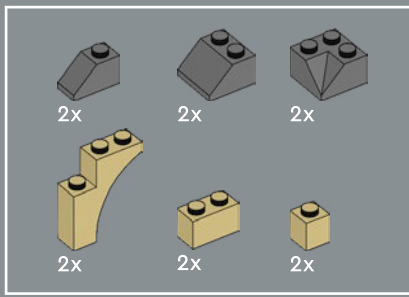

226

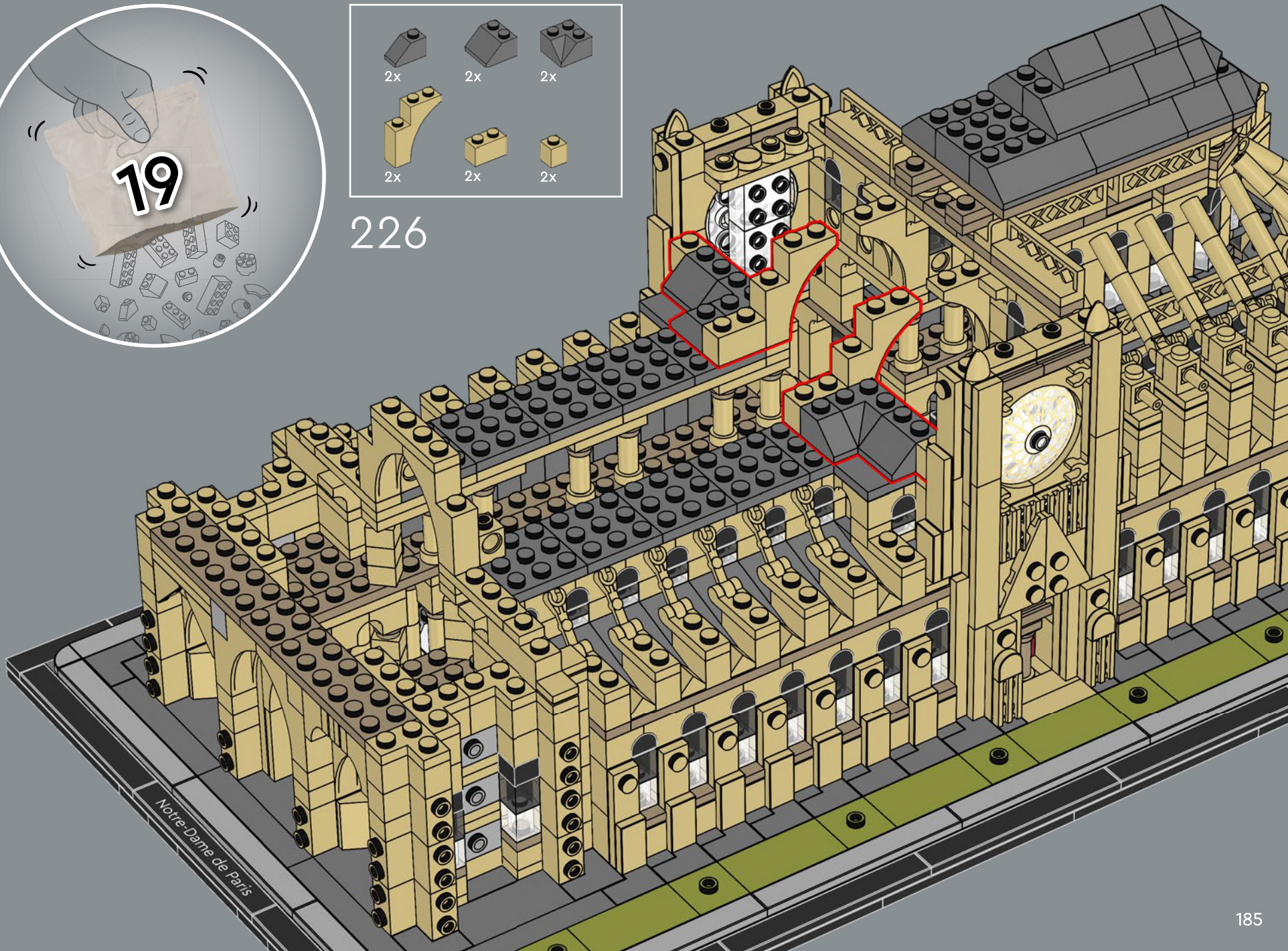

Notre-Dame de Paris



8x

227

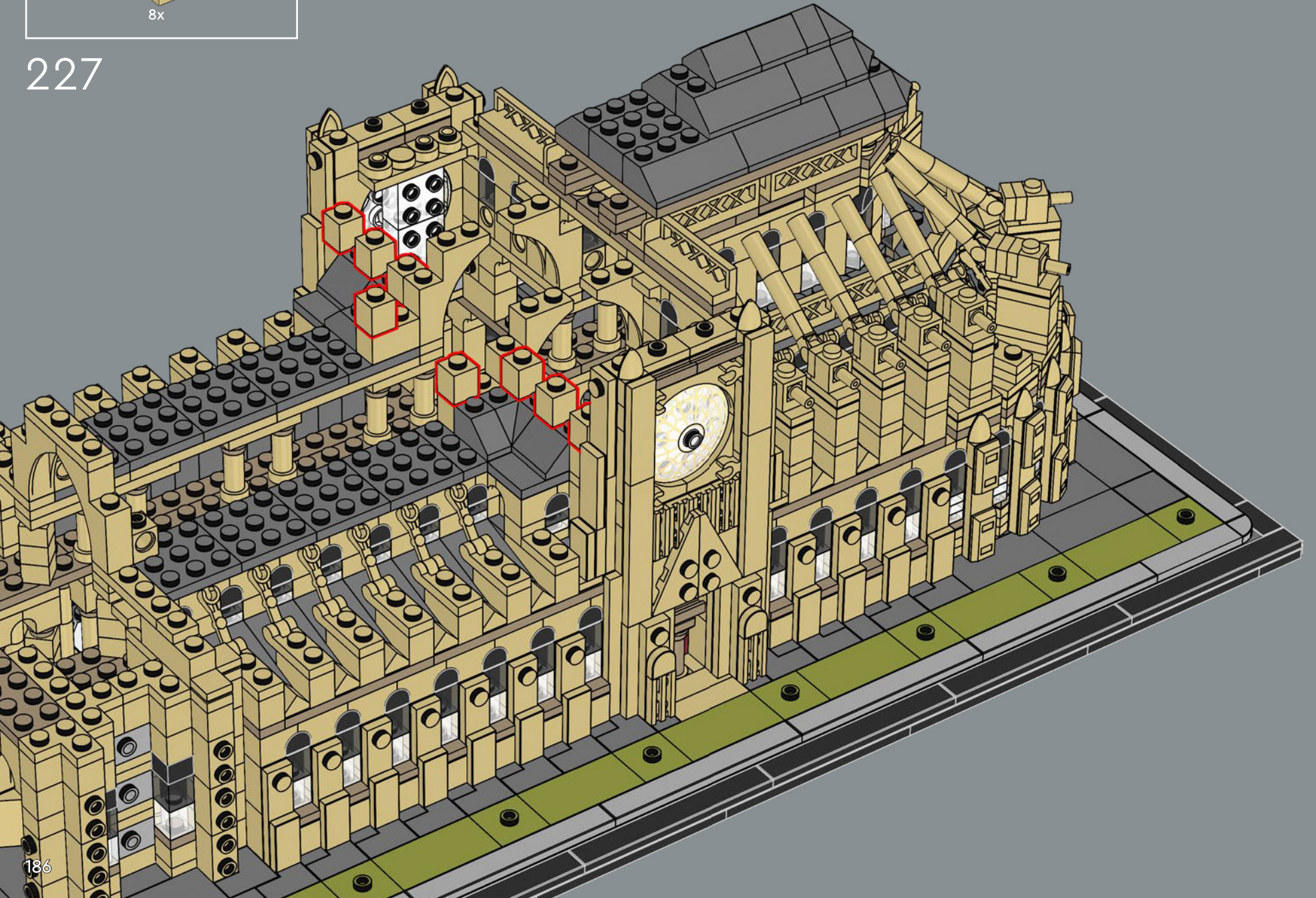

Le volte sono divise in sei parti da ogive - "volta esapartita".  
Il modello LEGO® segue l'originale incorporando un'ogiva  
(nervatura) trasversale in ogni secondo capitello.

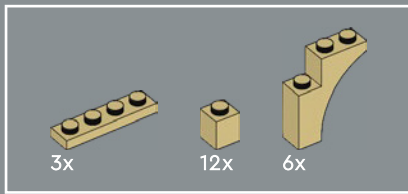

228

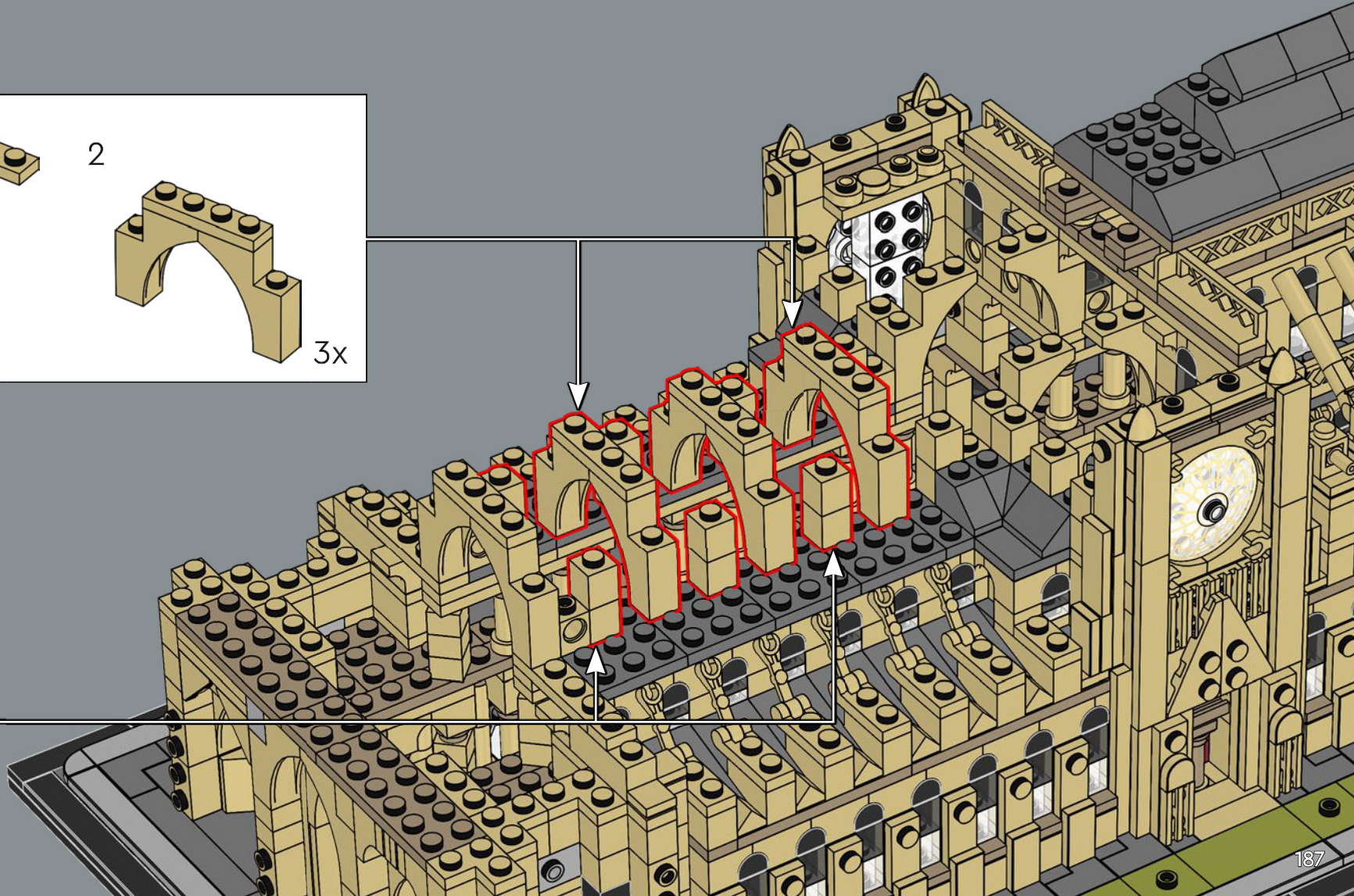
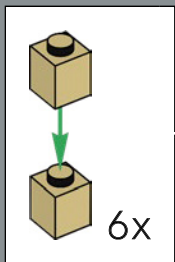
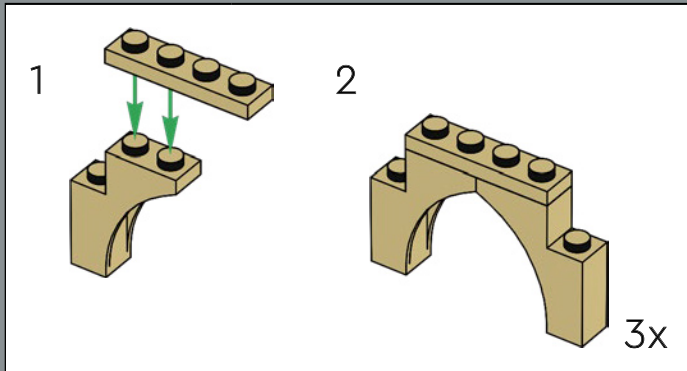



12x



20x



20x

229



8x



12x

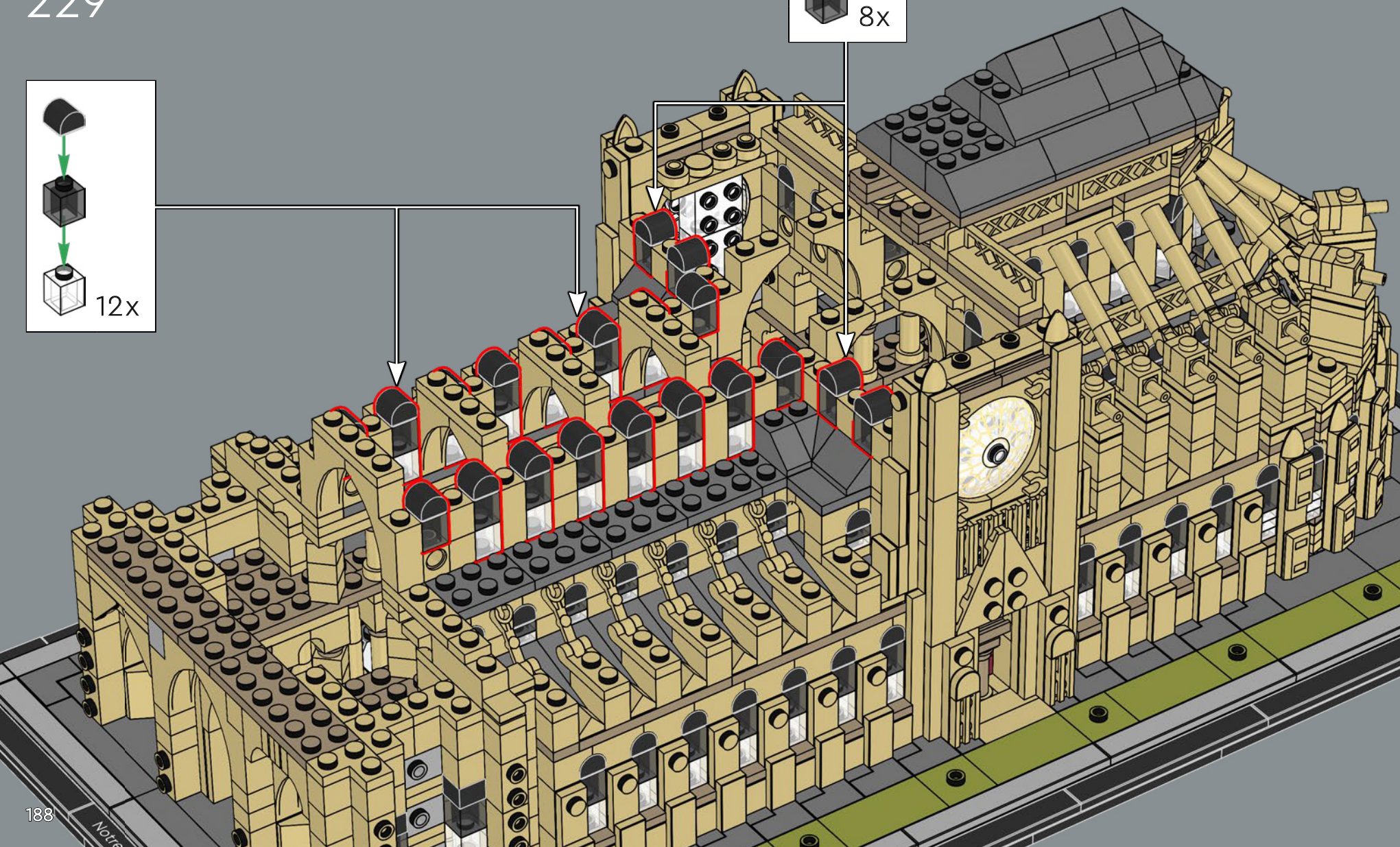

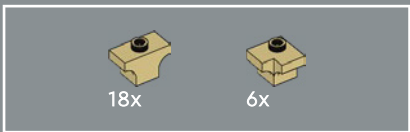

230

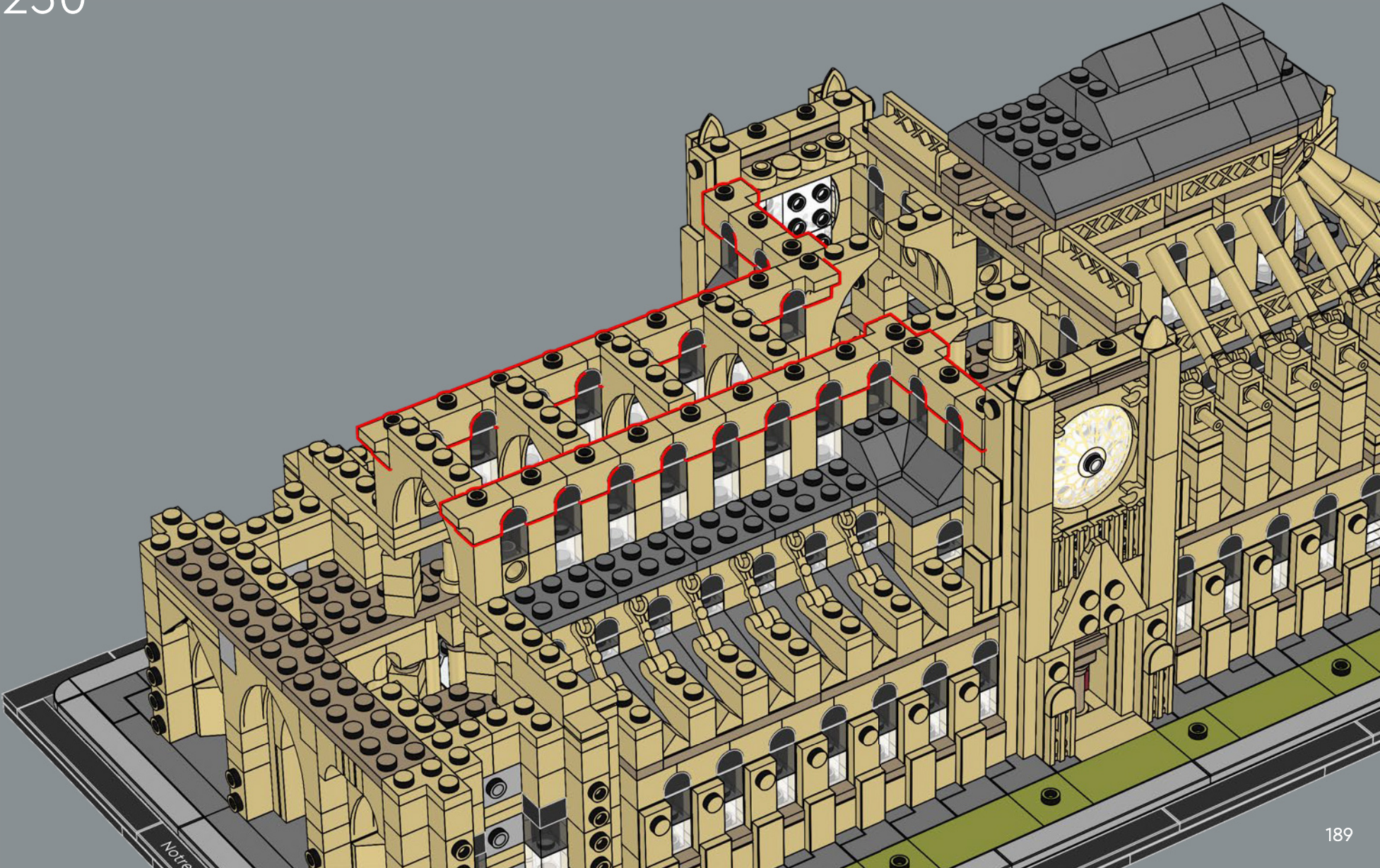

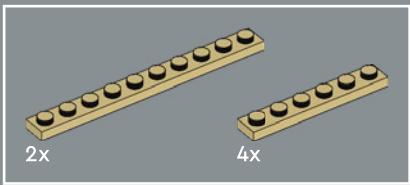

231

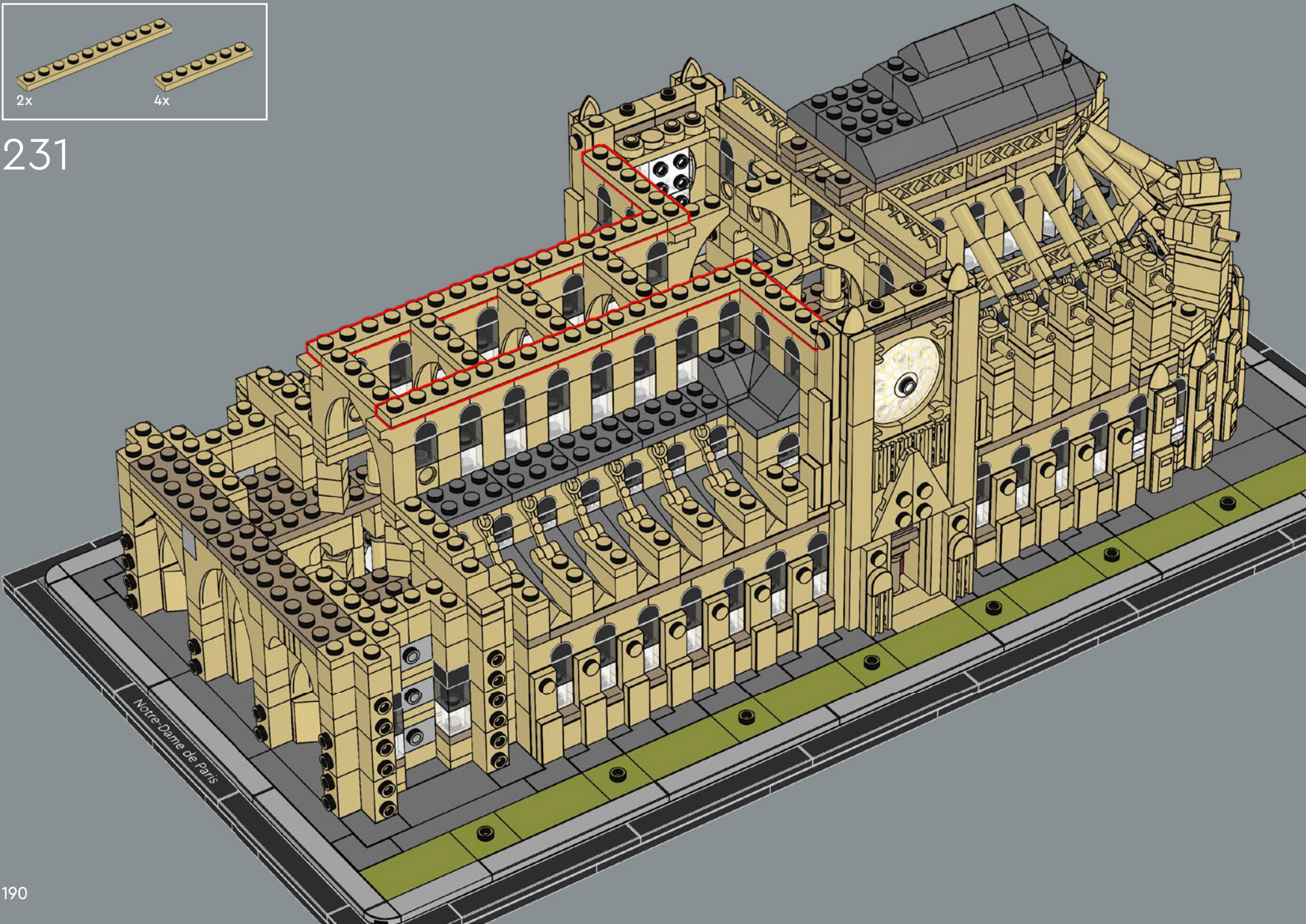

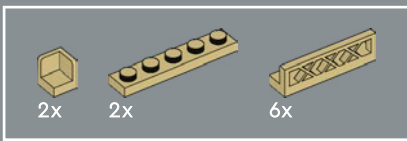

232

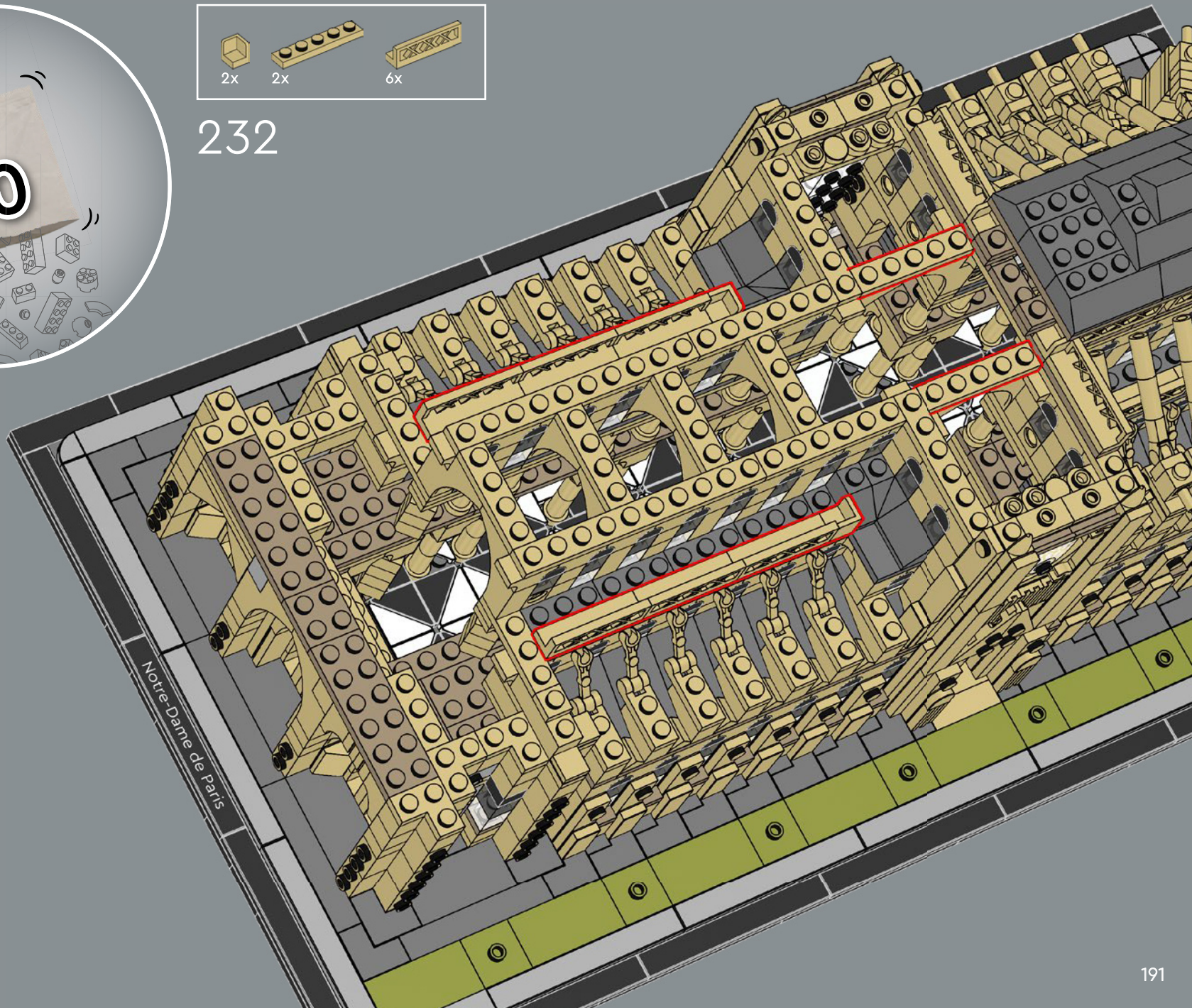

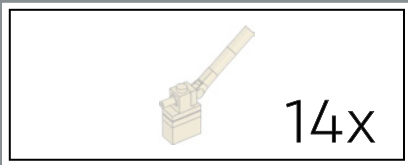

Gli archi rampanti di questo modello LEGO® sono dotati di fori attraverso elementi candela per imitare i canali d'acqua dei veri contrafforti.

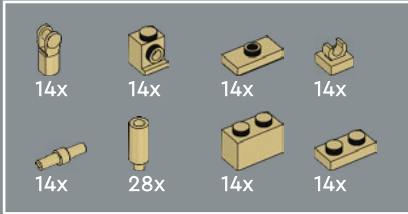

233

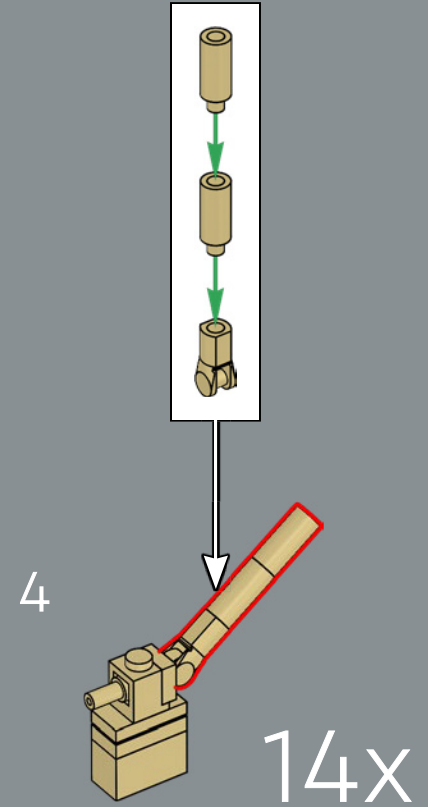
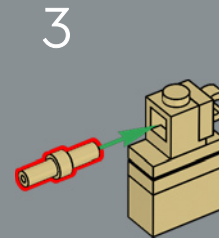
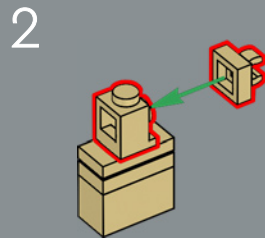
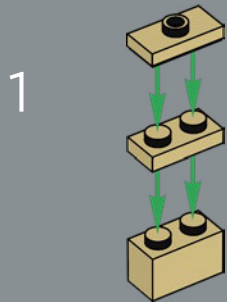



Nel 1225, gli archi rampanti della navata furono dotati di canali che drenavano l'acqua piovana dal tetto attraverso i doccioni.

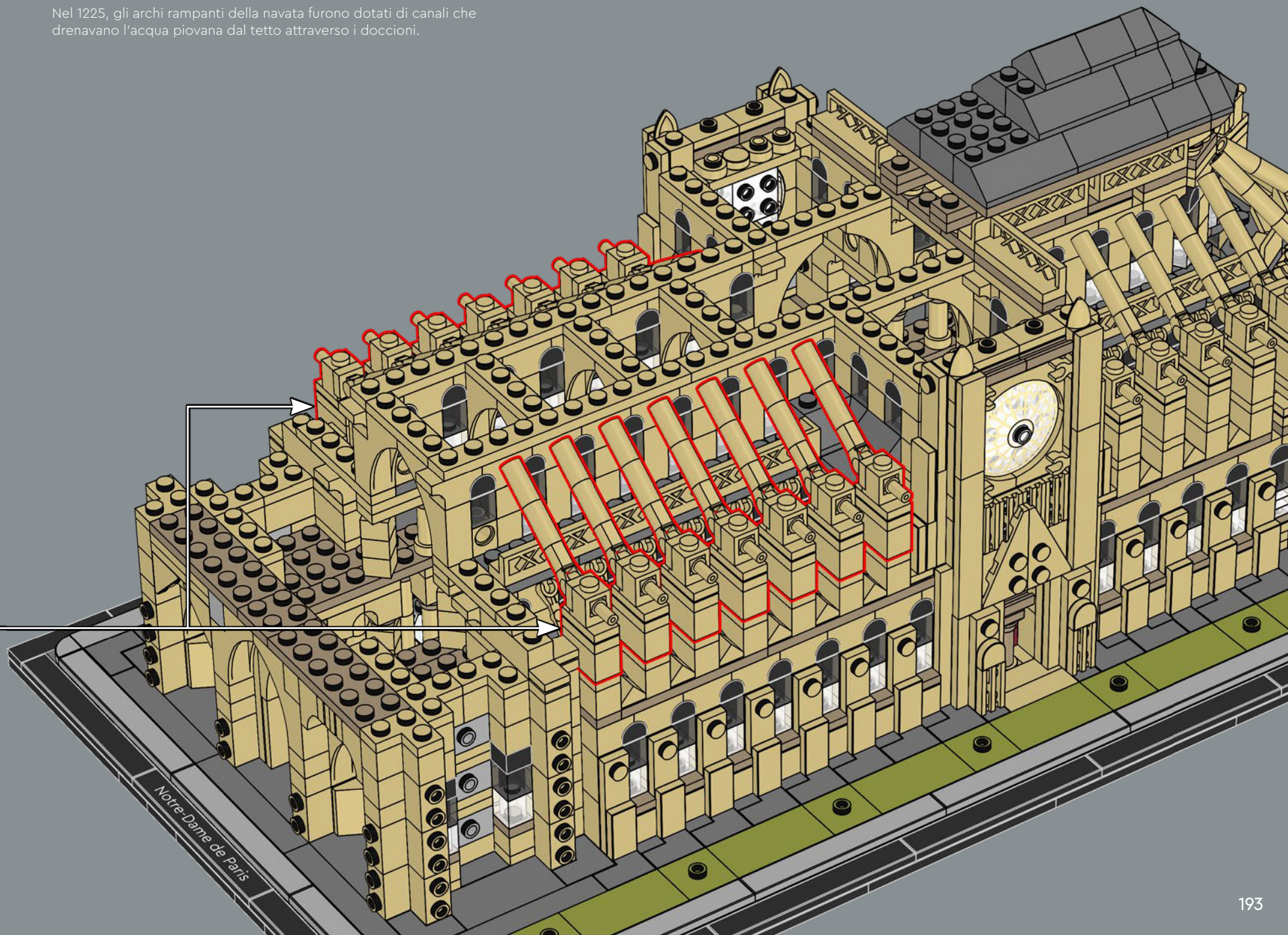

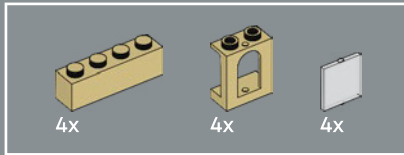
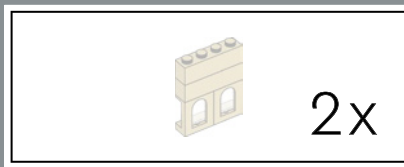

234

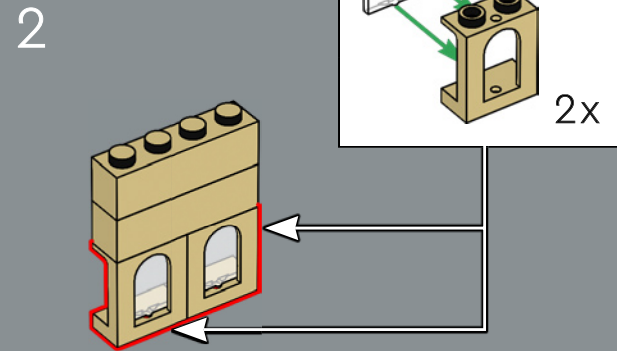
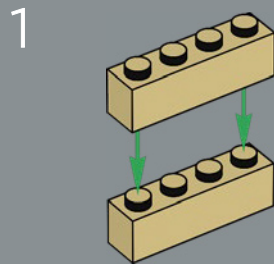

2x

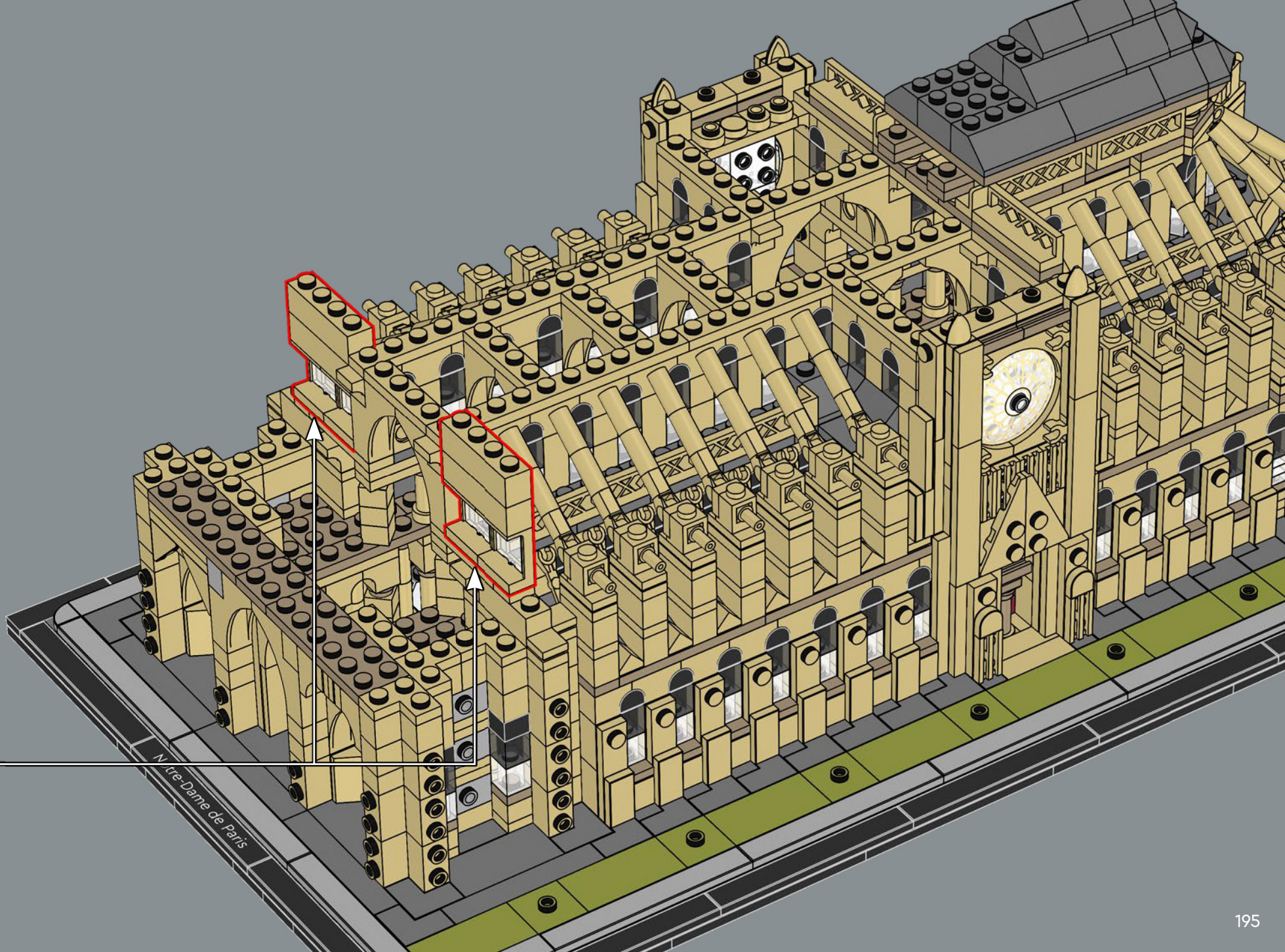

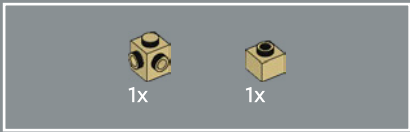

235

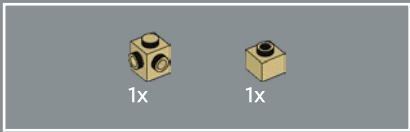
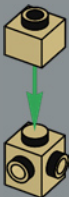

236

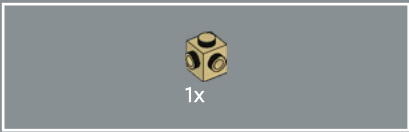

237

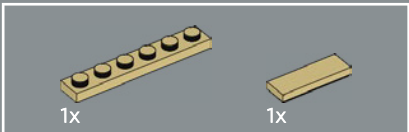

238

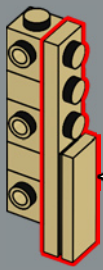
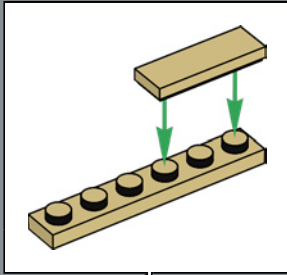

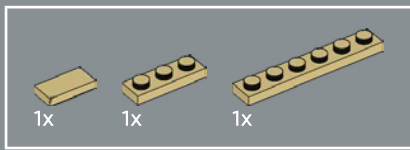

239

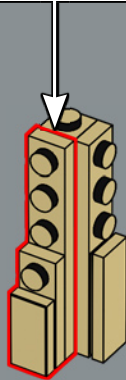
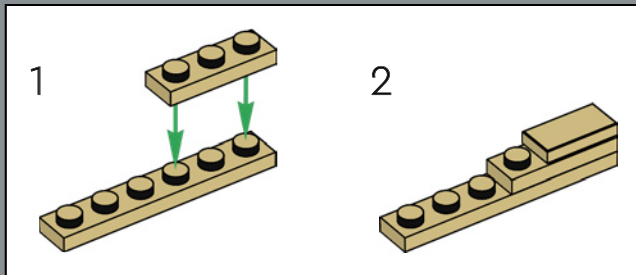

240

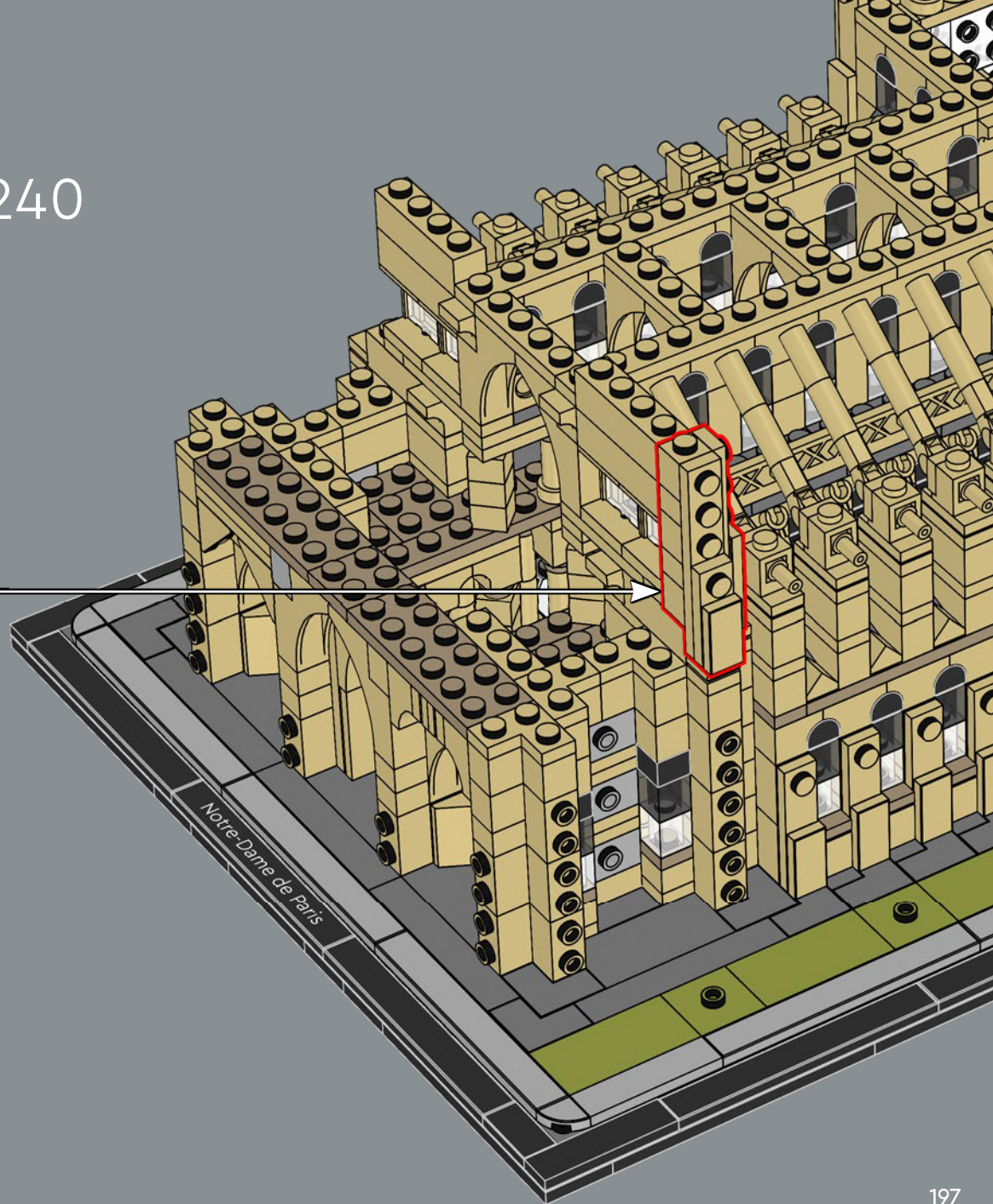

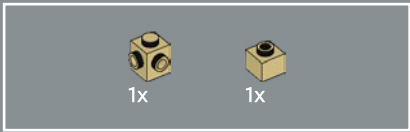

241

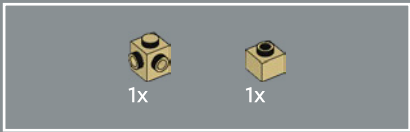
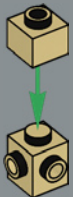

242



243

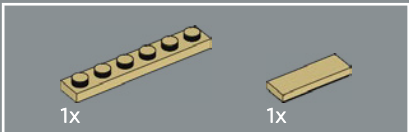

244

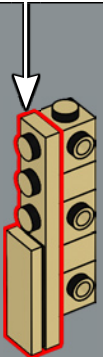
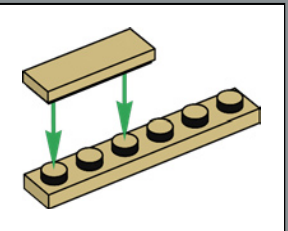

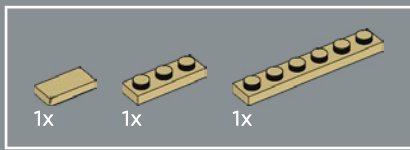

245

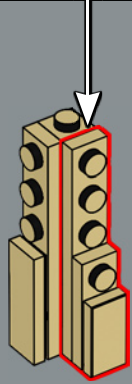
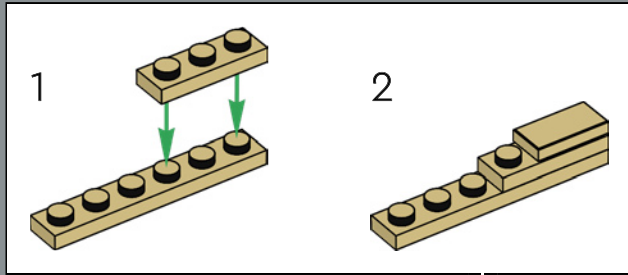

246

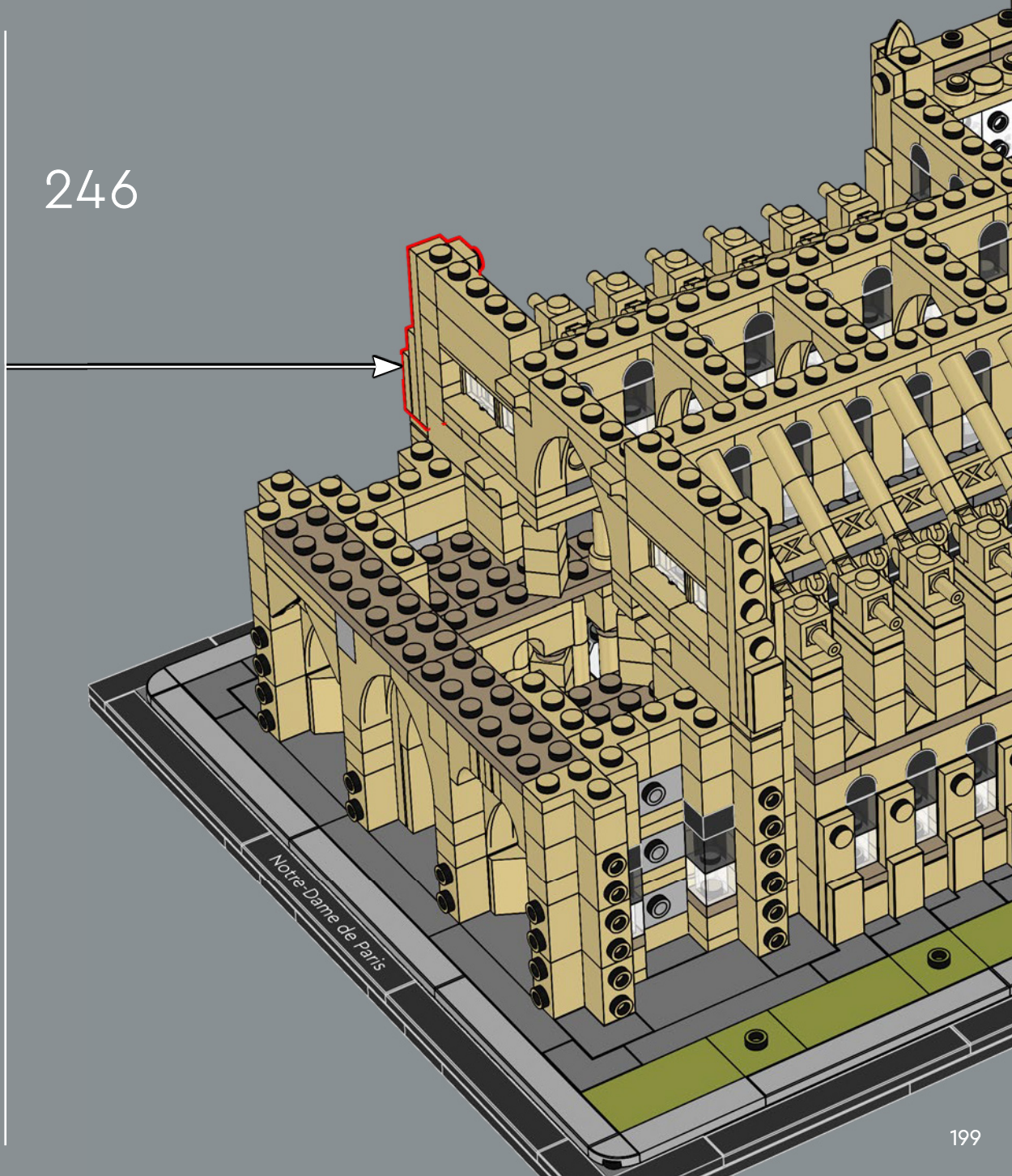



247

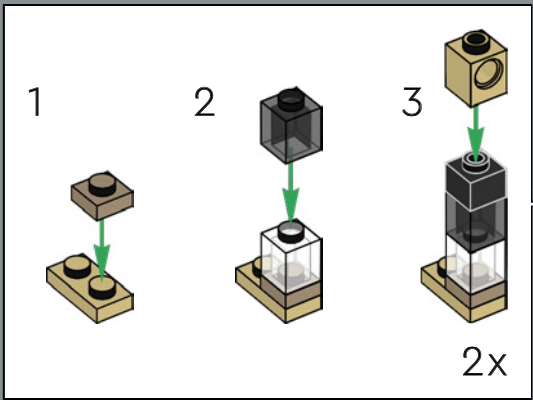



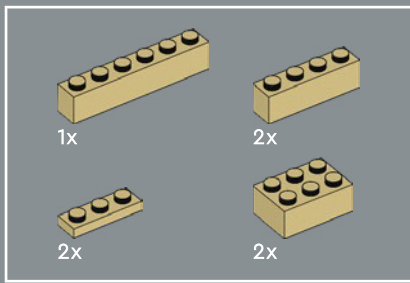

248

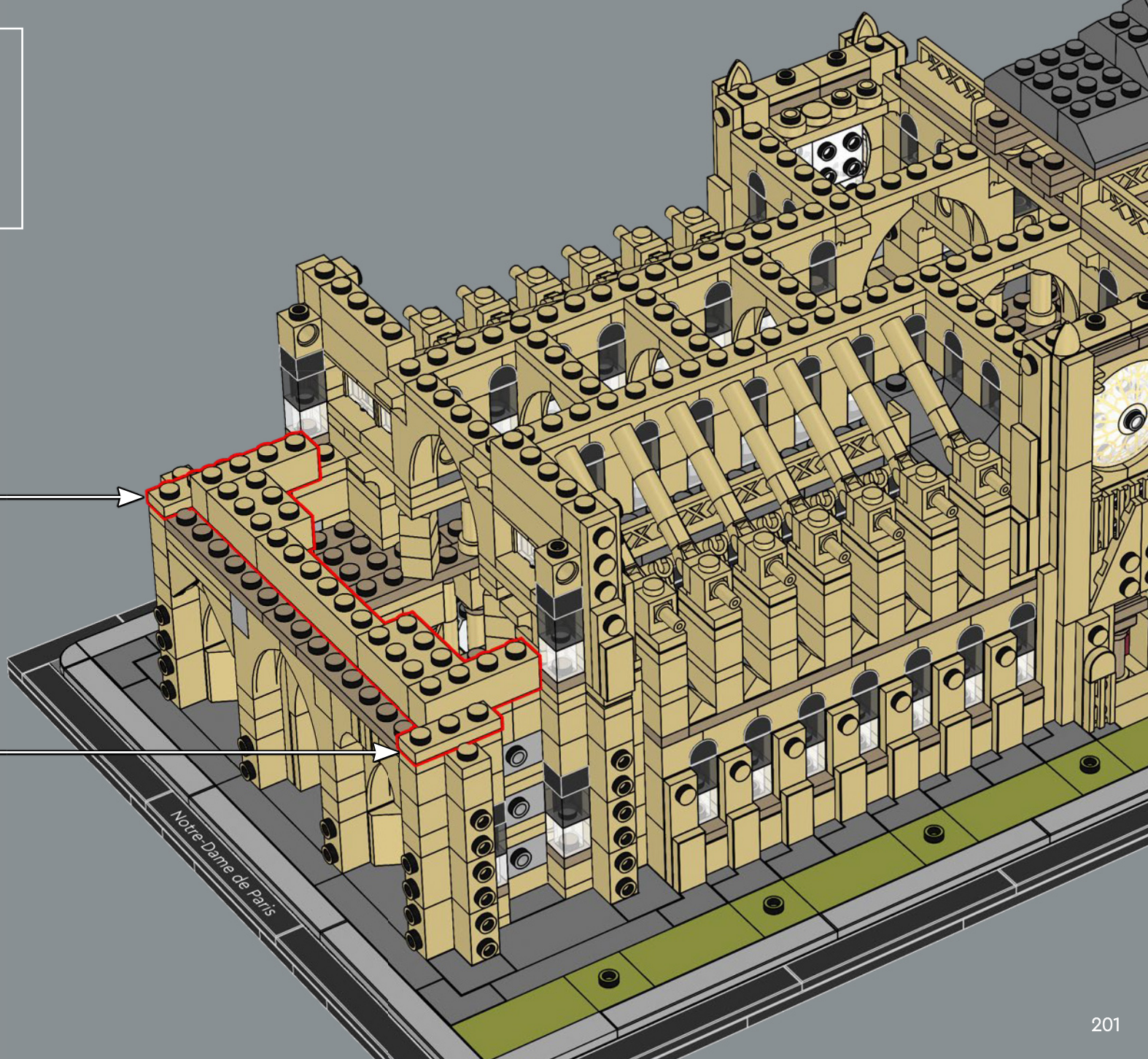
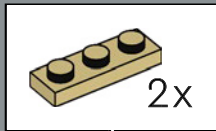

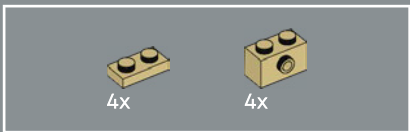

249

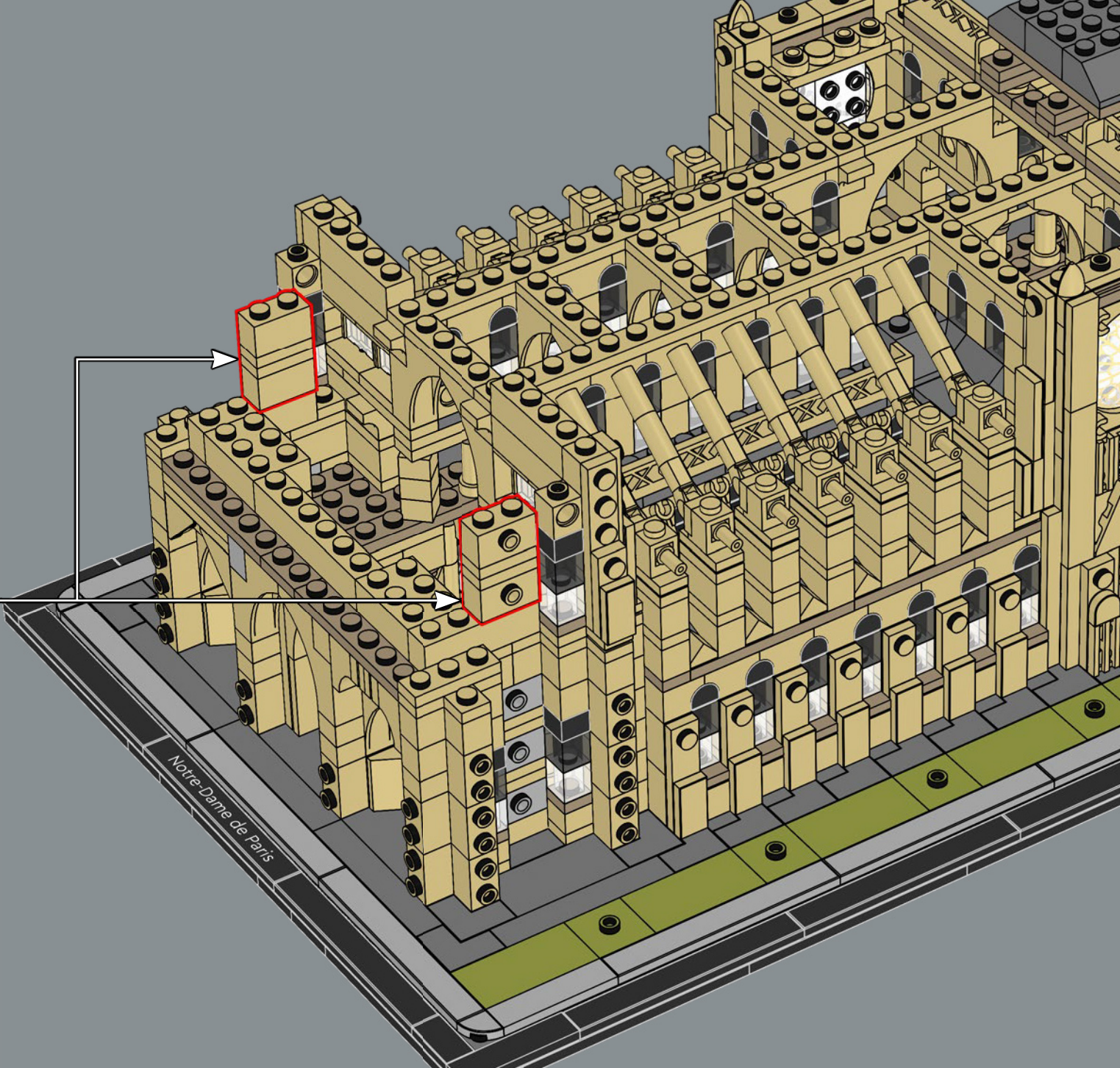
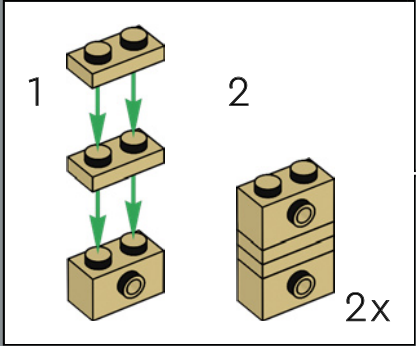

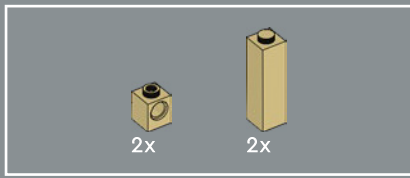

250

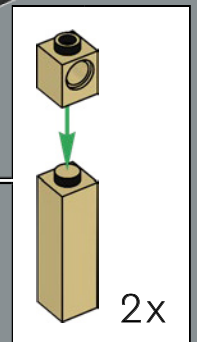
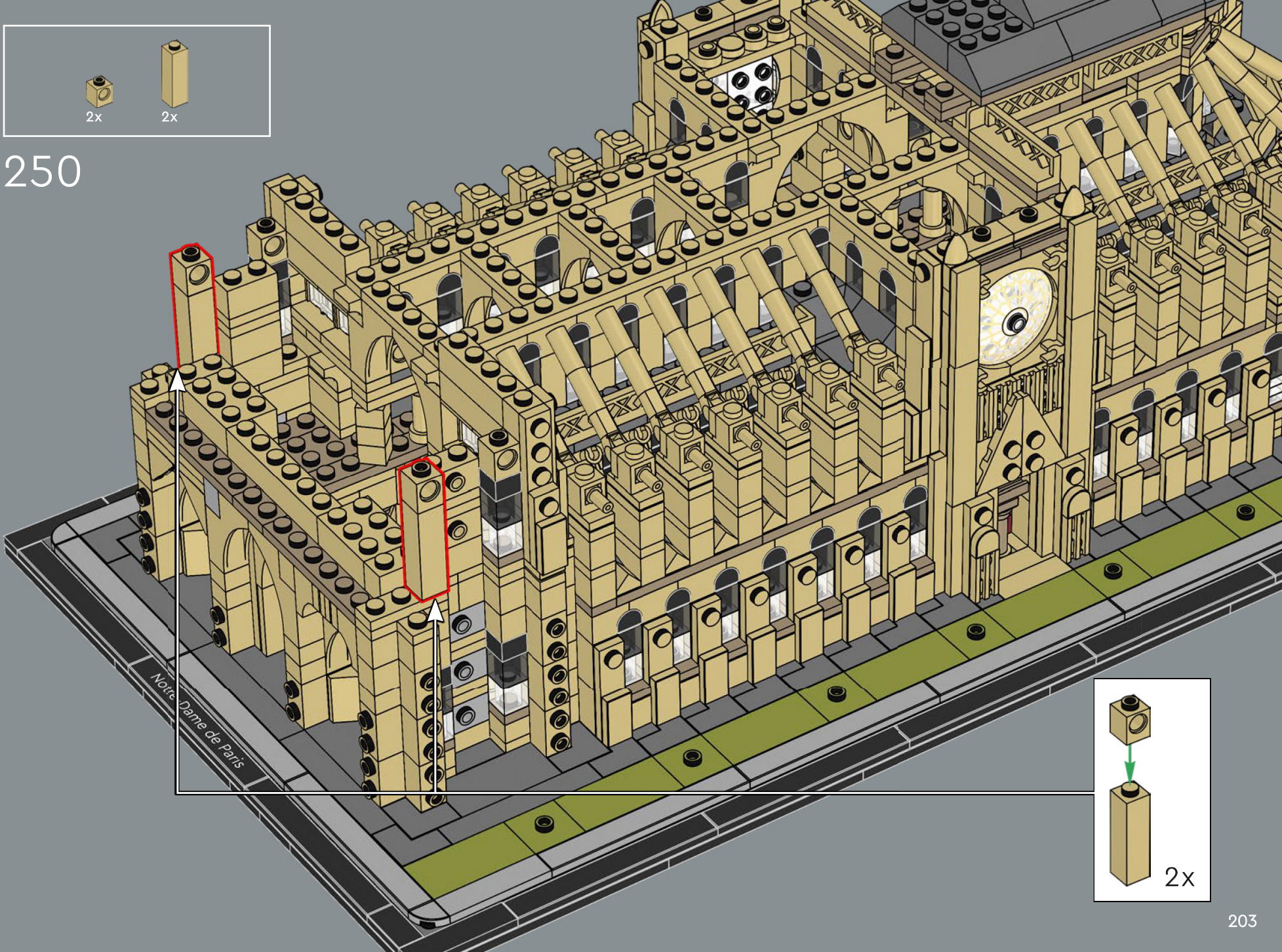

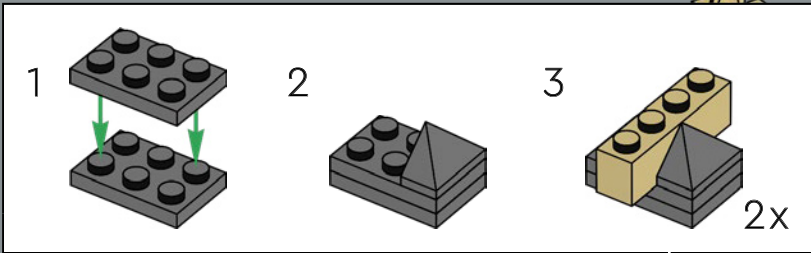
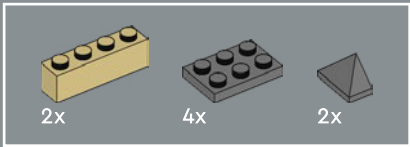

251

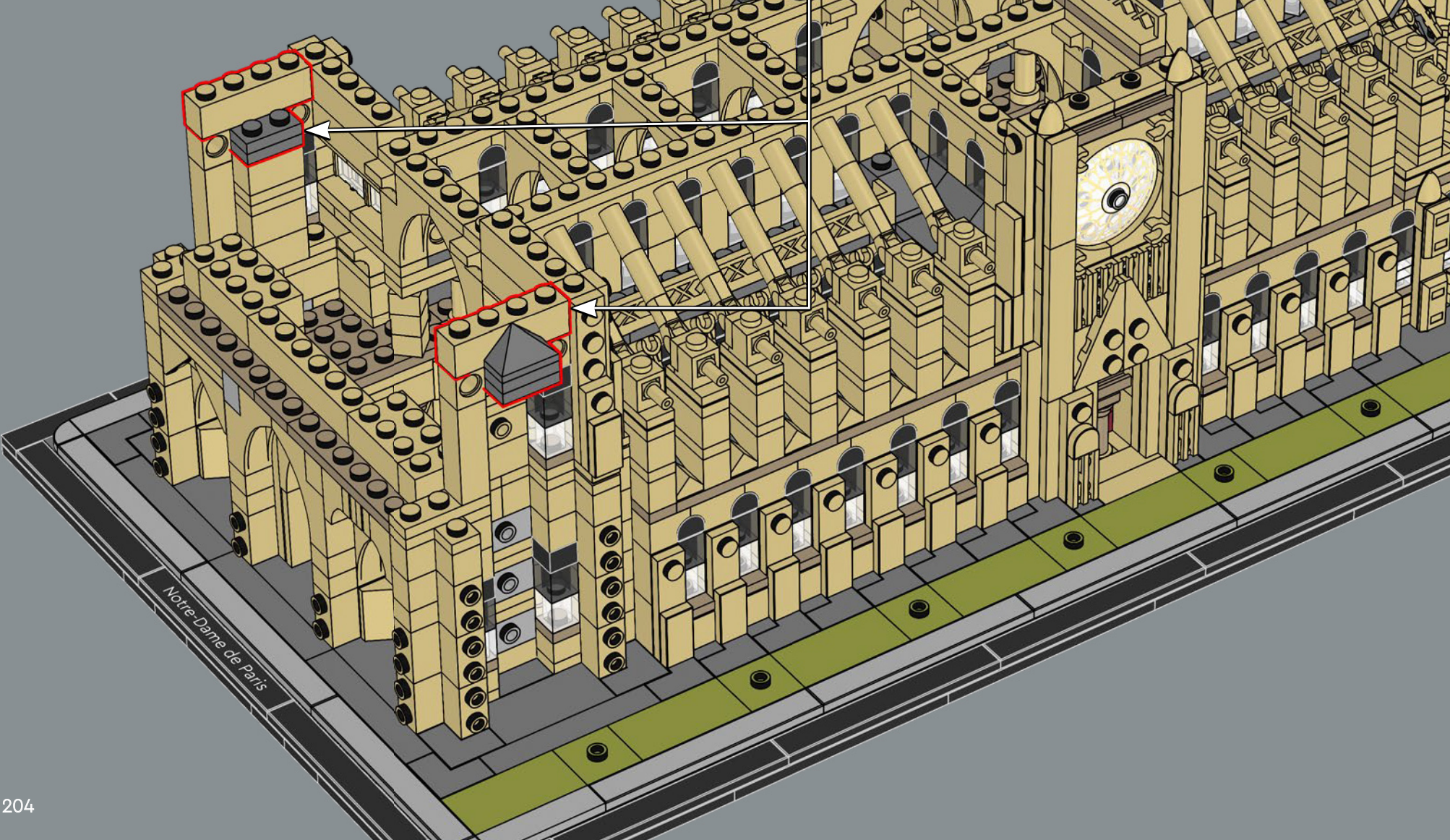

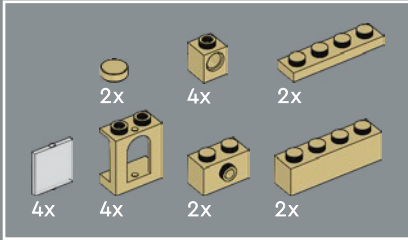
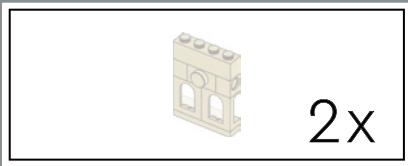

252

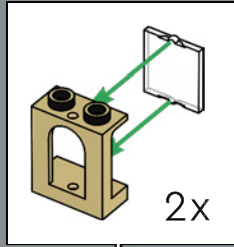

1

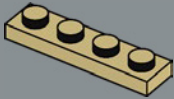

2

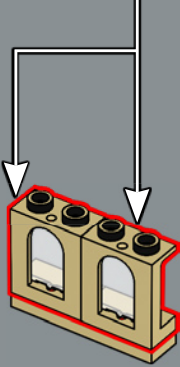

3

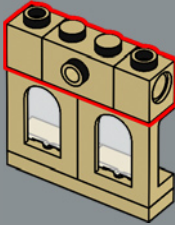

4

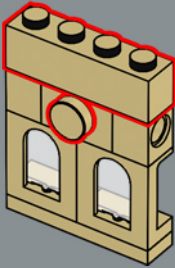

2x

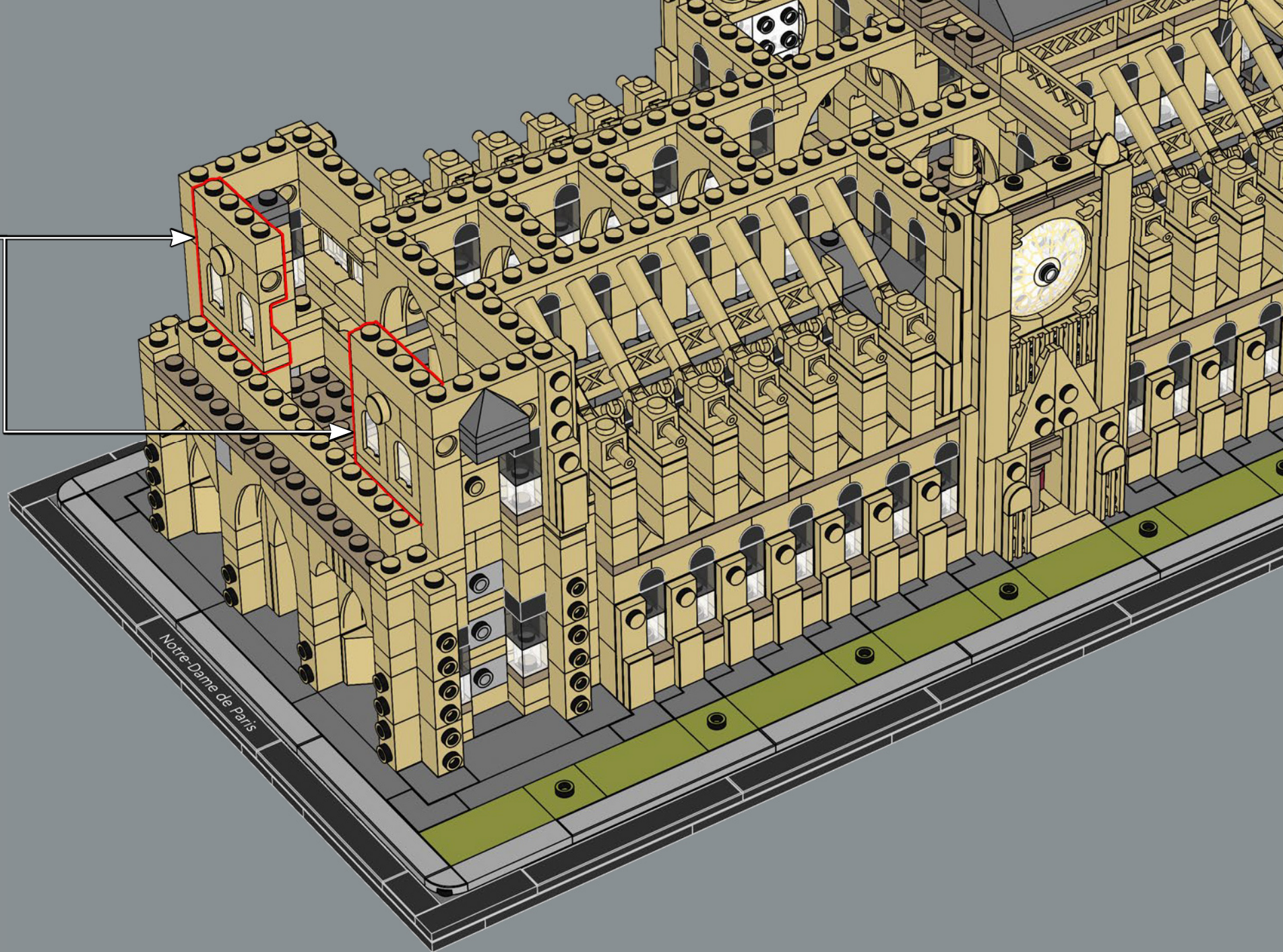

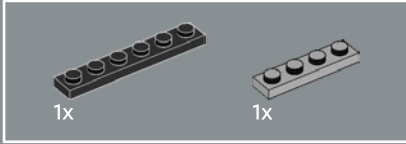
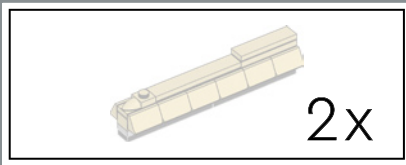

253

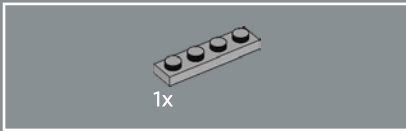
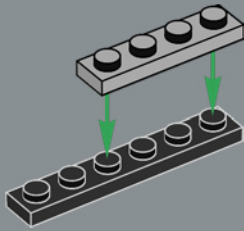

254

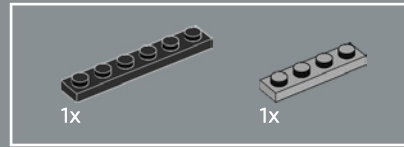
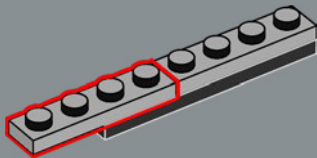

255

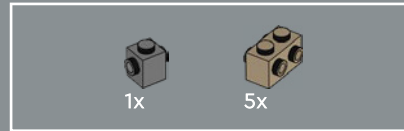
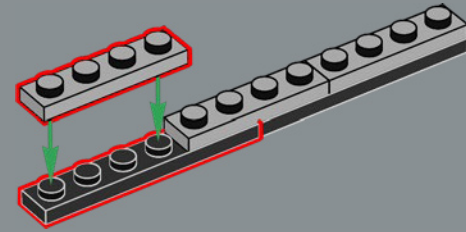

256

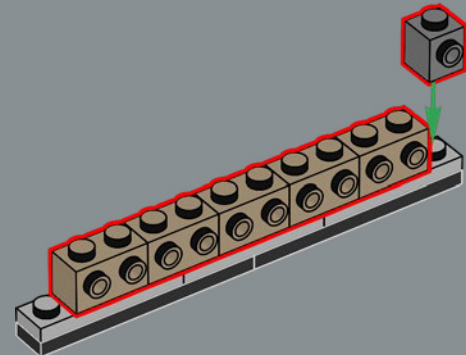

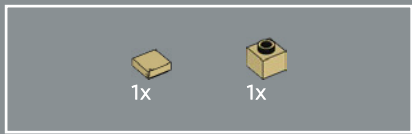

257

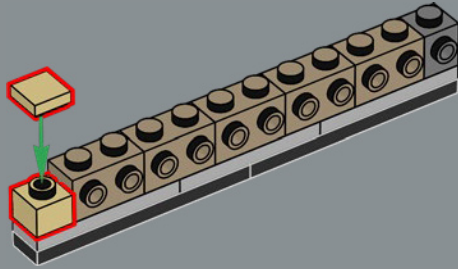

258

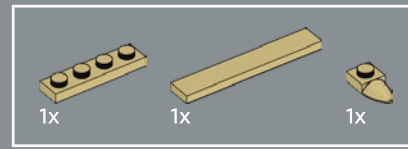
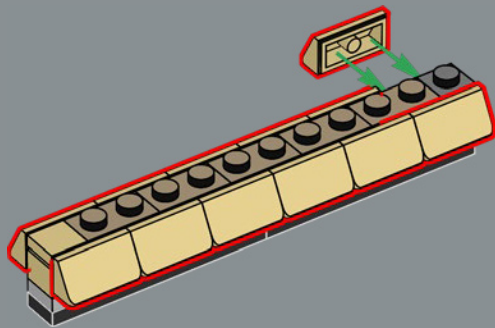

259

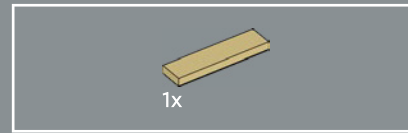
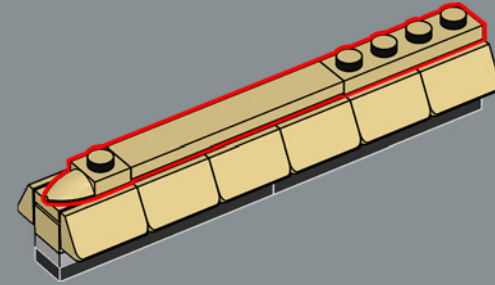

260

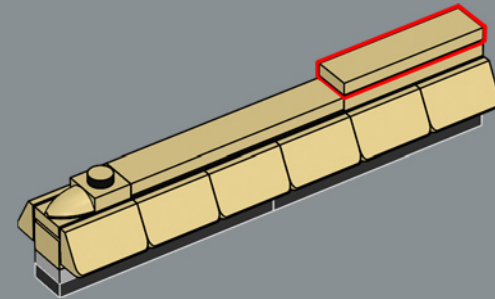

2x



261



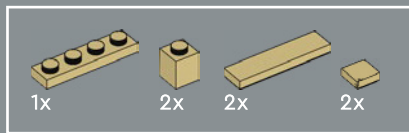

262

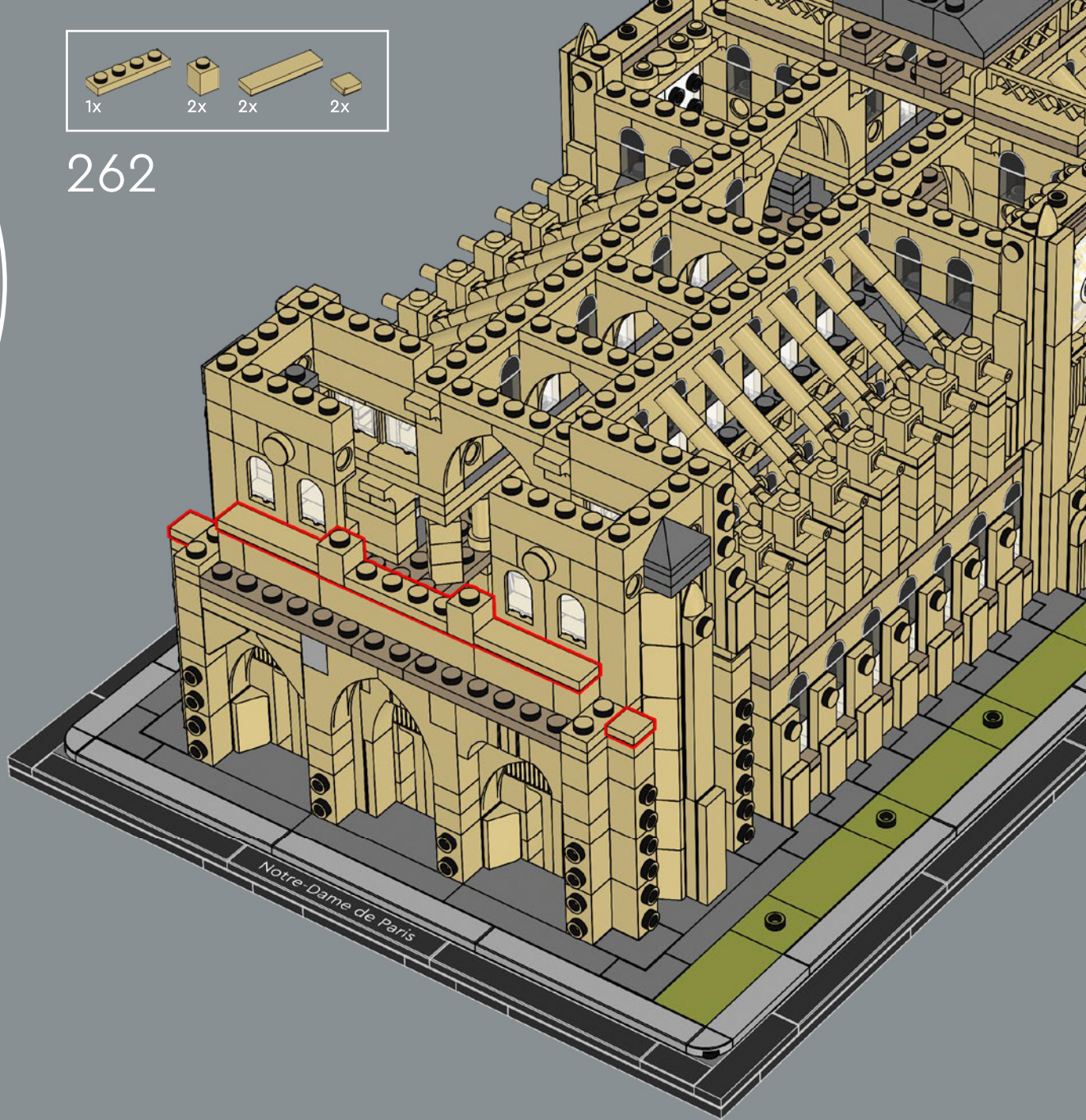



263



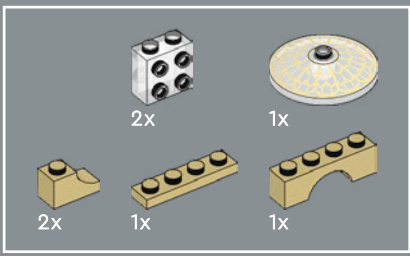

264

1

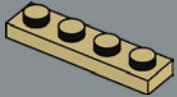

2

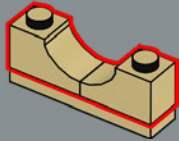

3

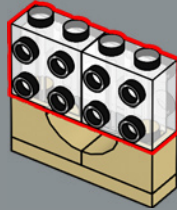

4

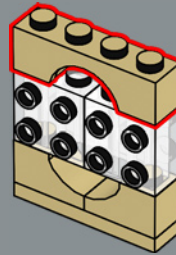

5



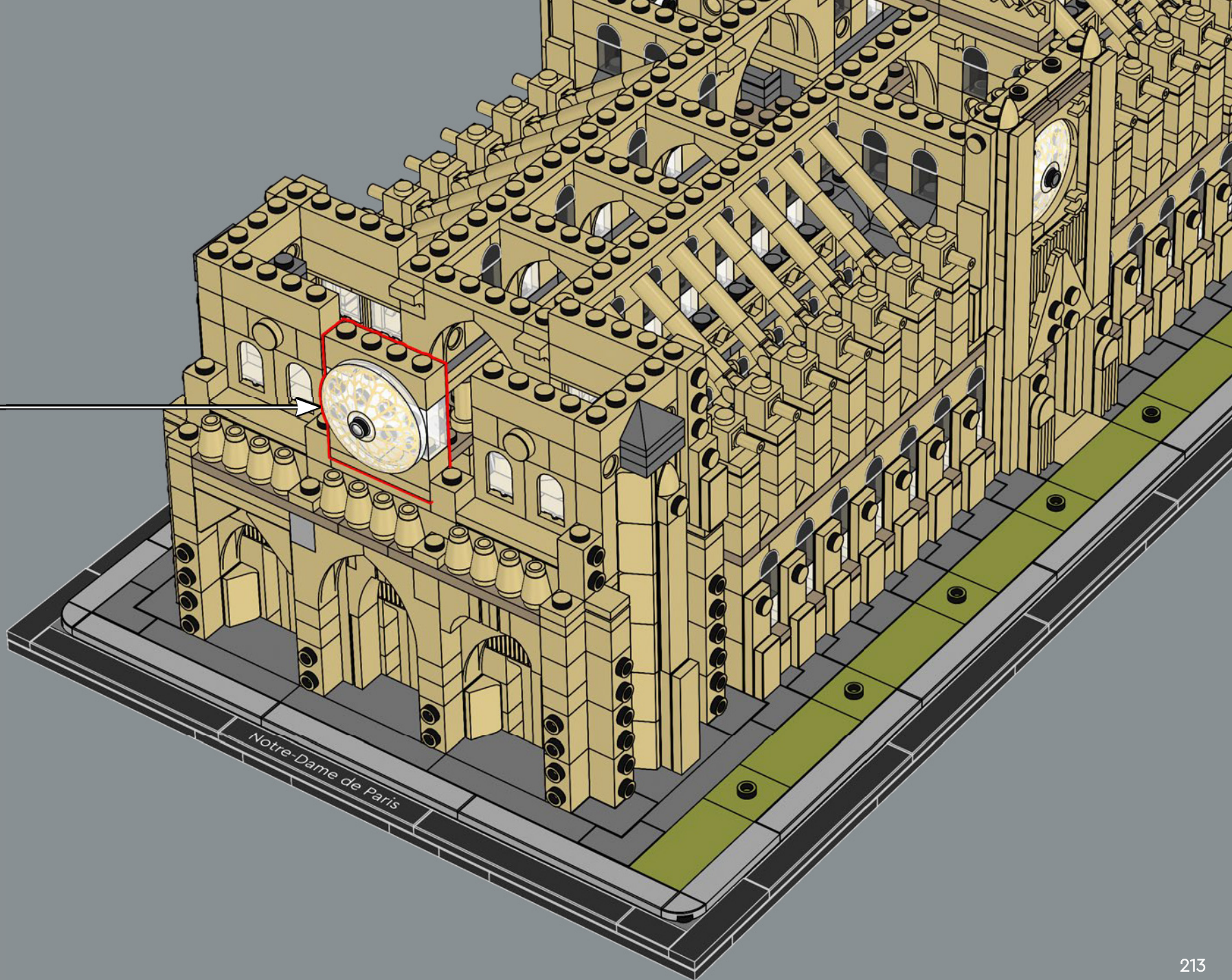

Notre-Dame de Paris

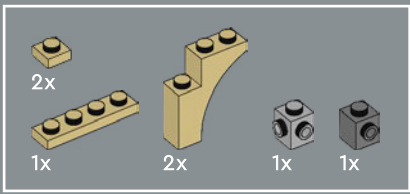

# 265

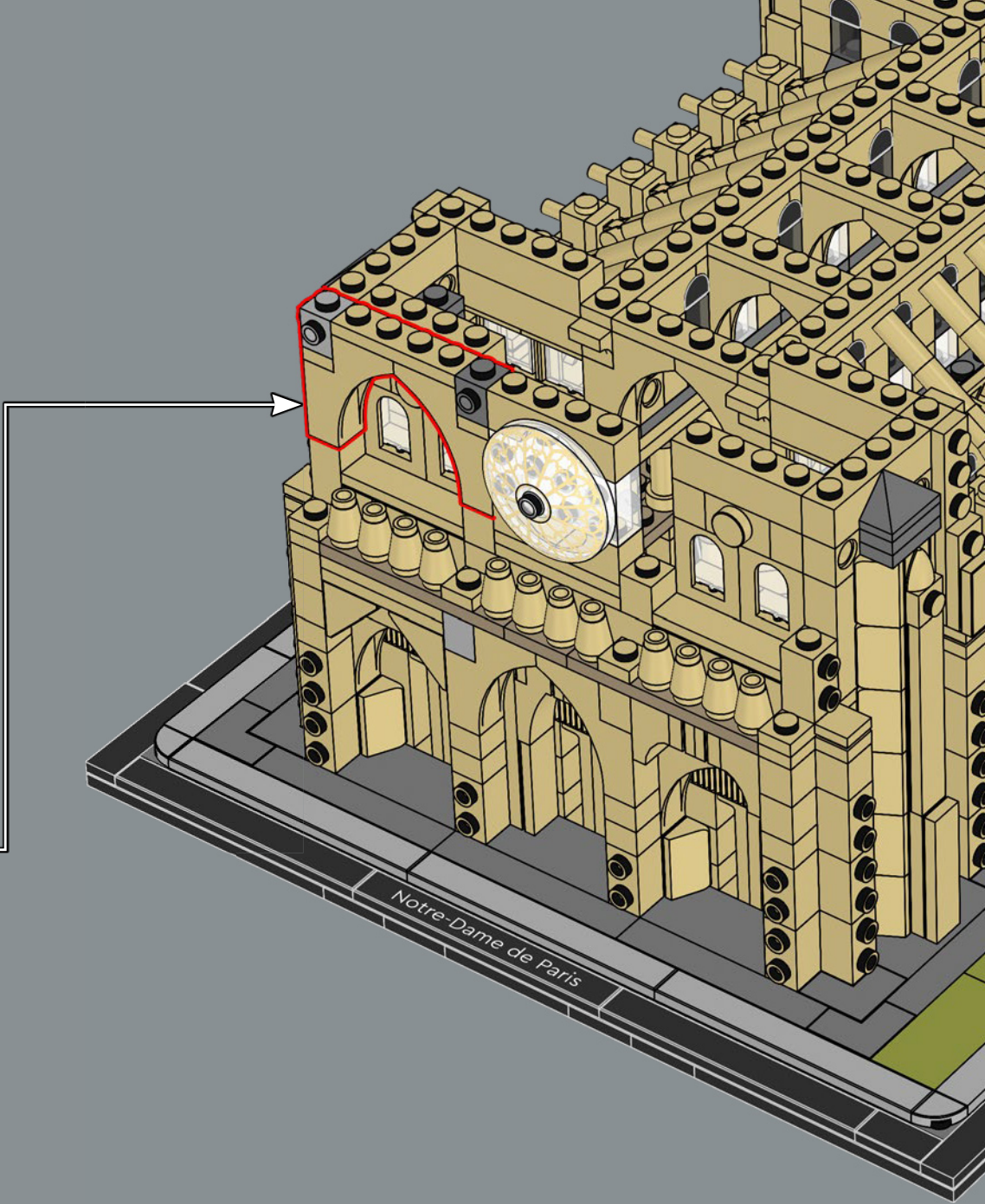
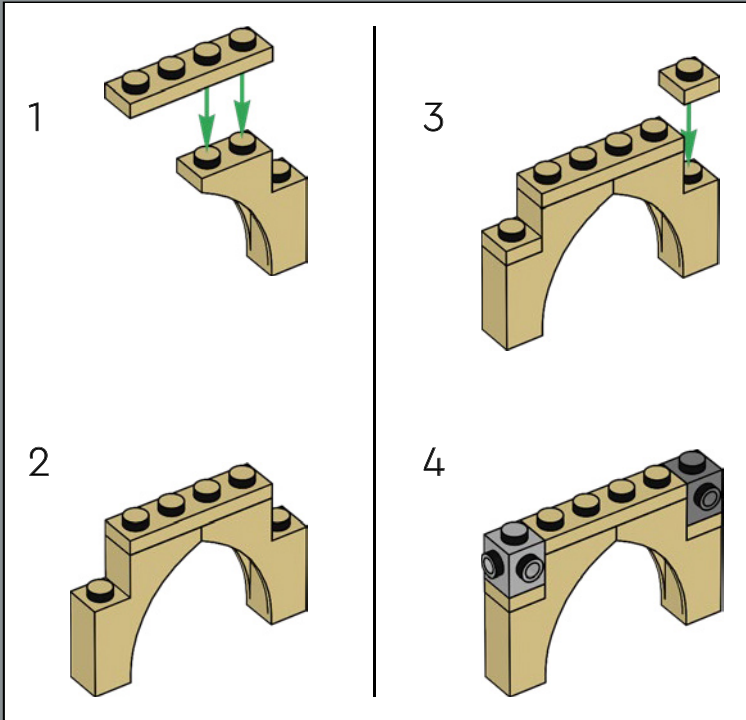

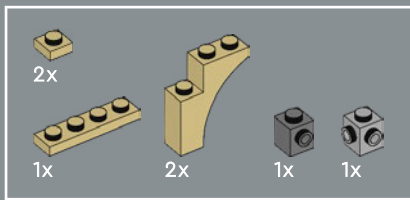

266

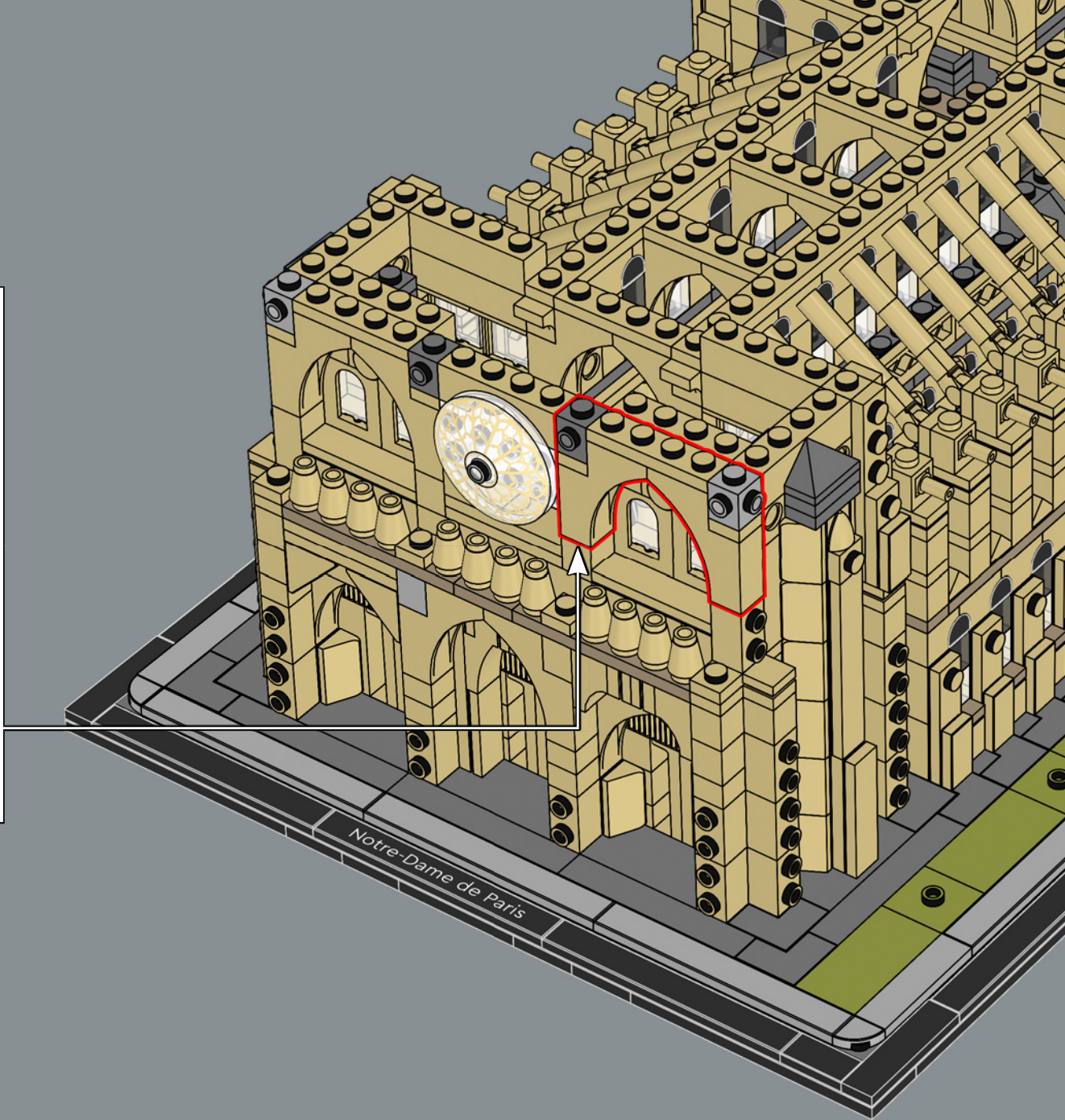
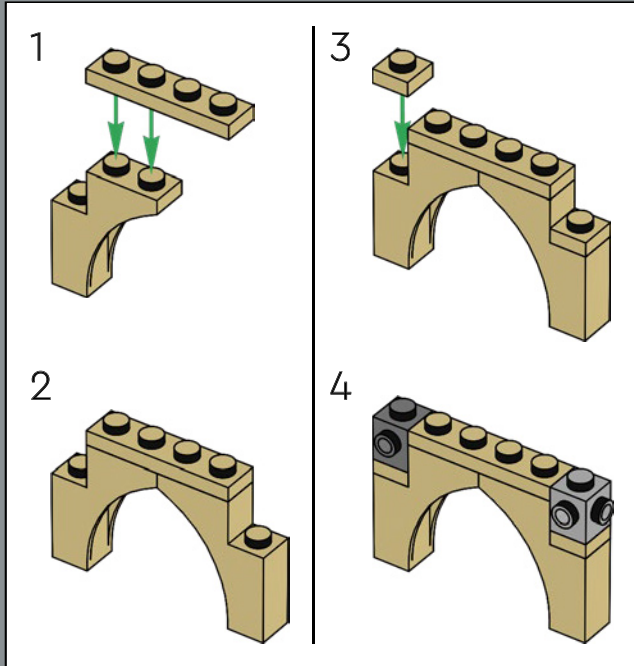

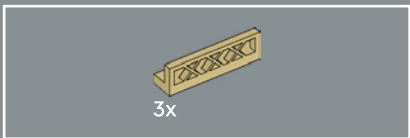

267

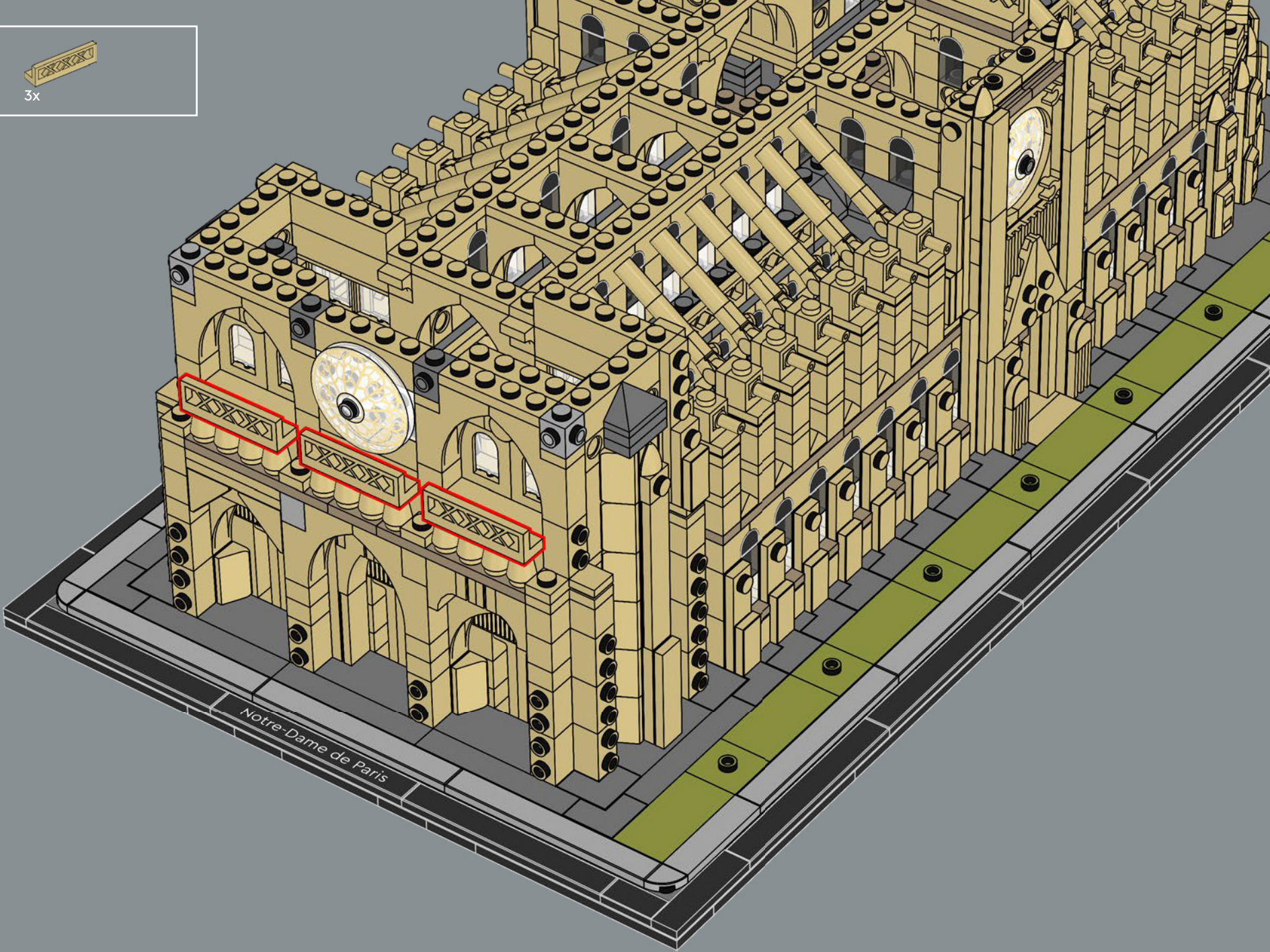



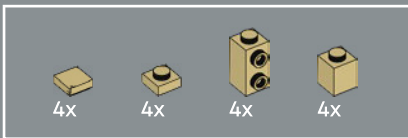

268

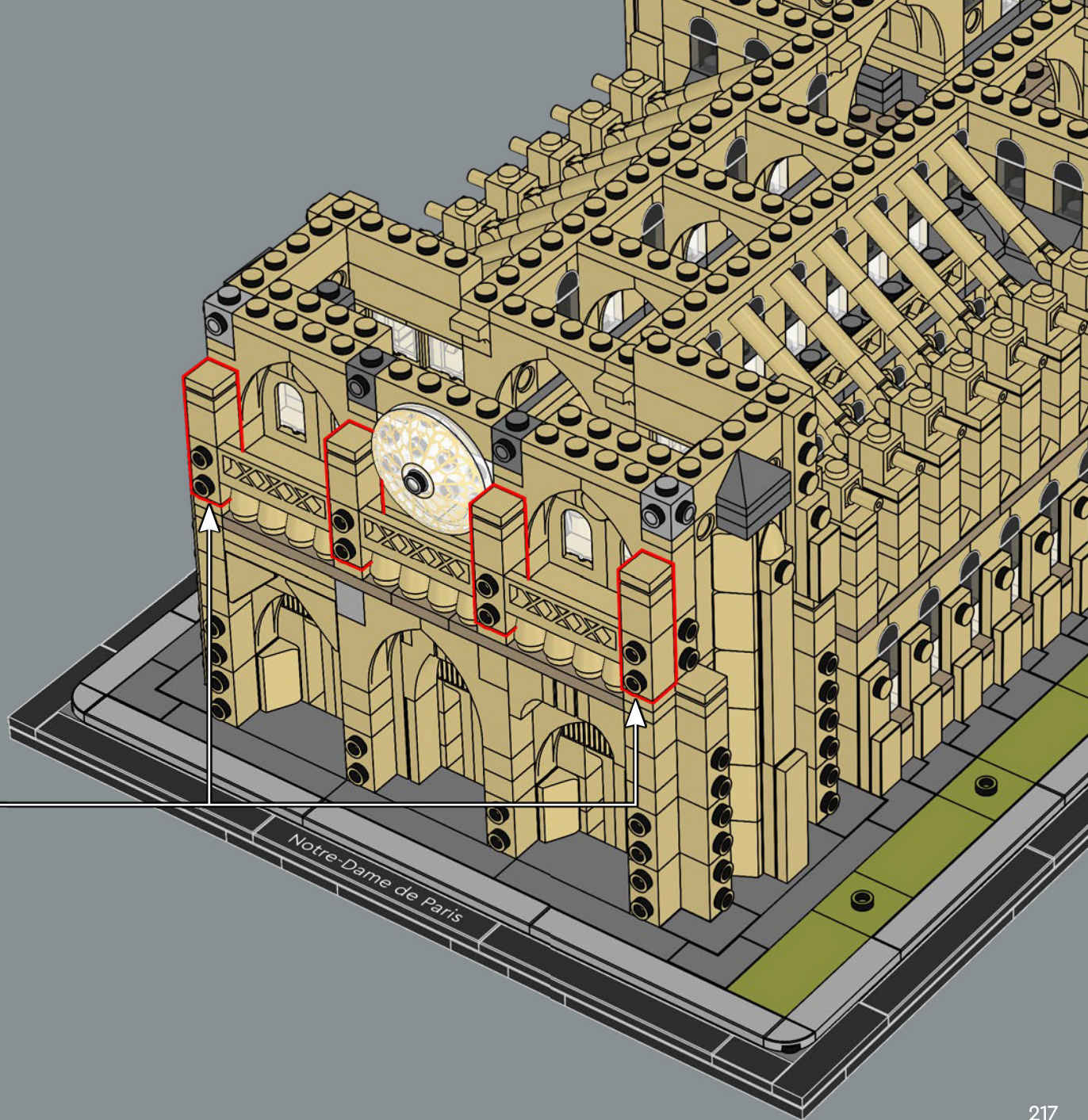
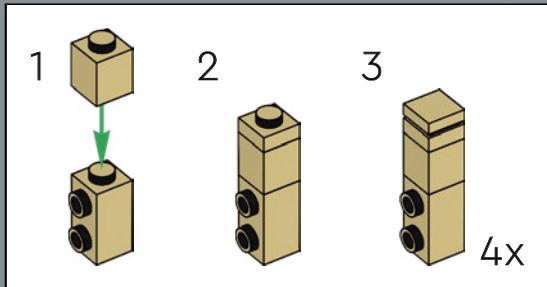

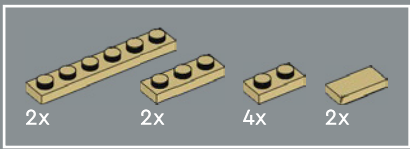

269

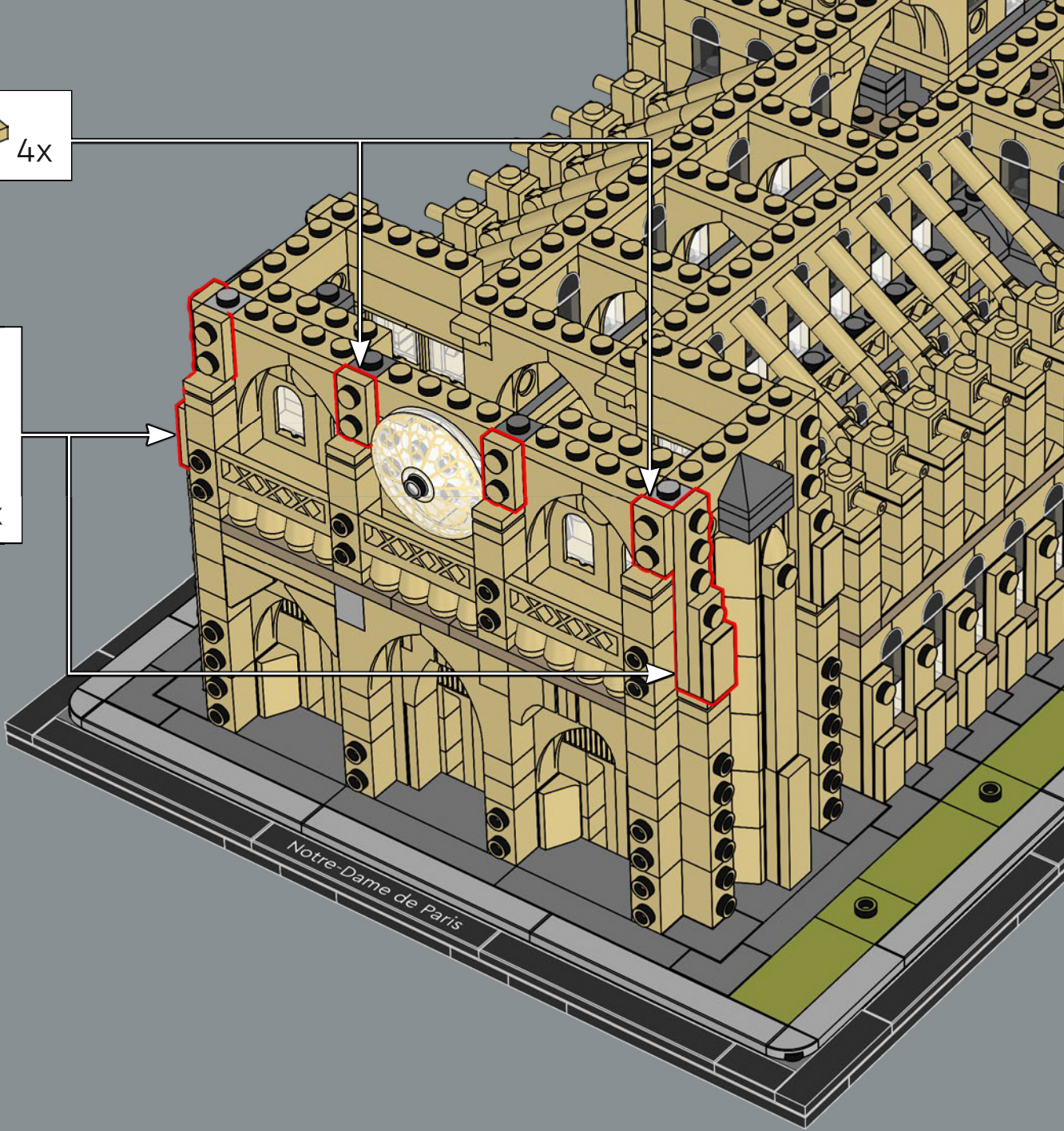
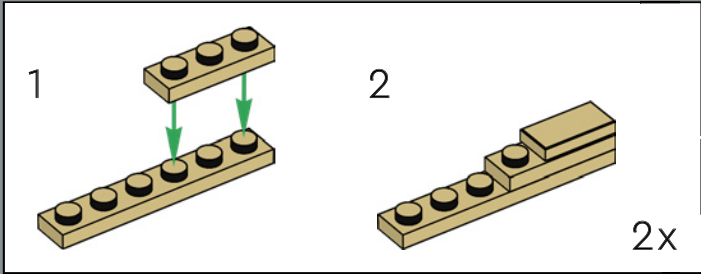
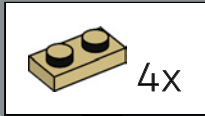

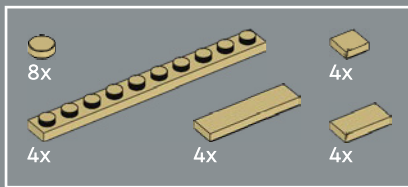

1220 – Tre portali, sui quali si erge la Galleria dei Re, accolgono i visitatori attraverso il maestoso ingresso della cattedrale. Le 28 statue colossali sono rappresentate da 20 coni LEGO® ed elementi rotondi.

270

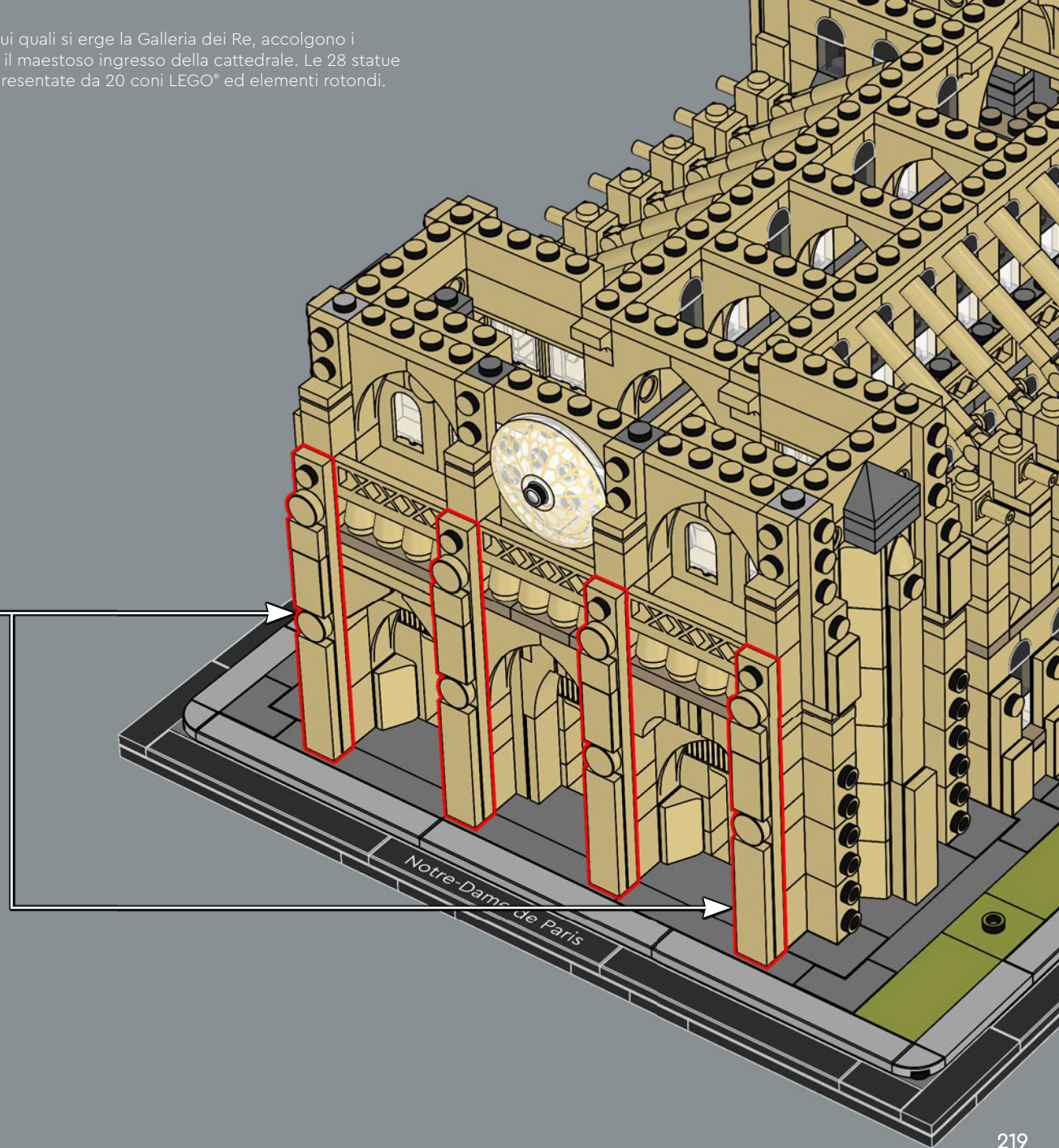
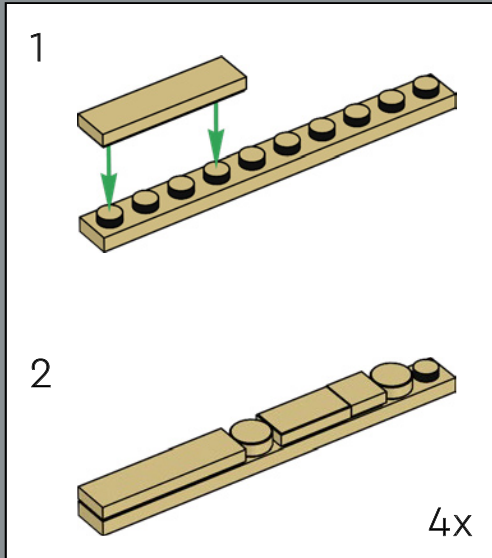

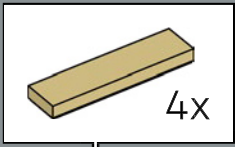
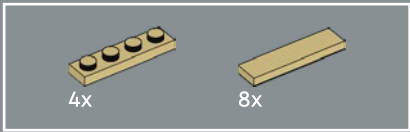

271

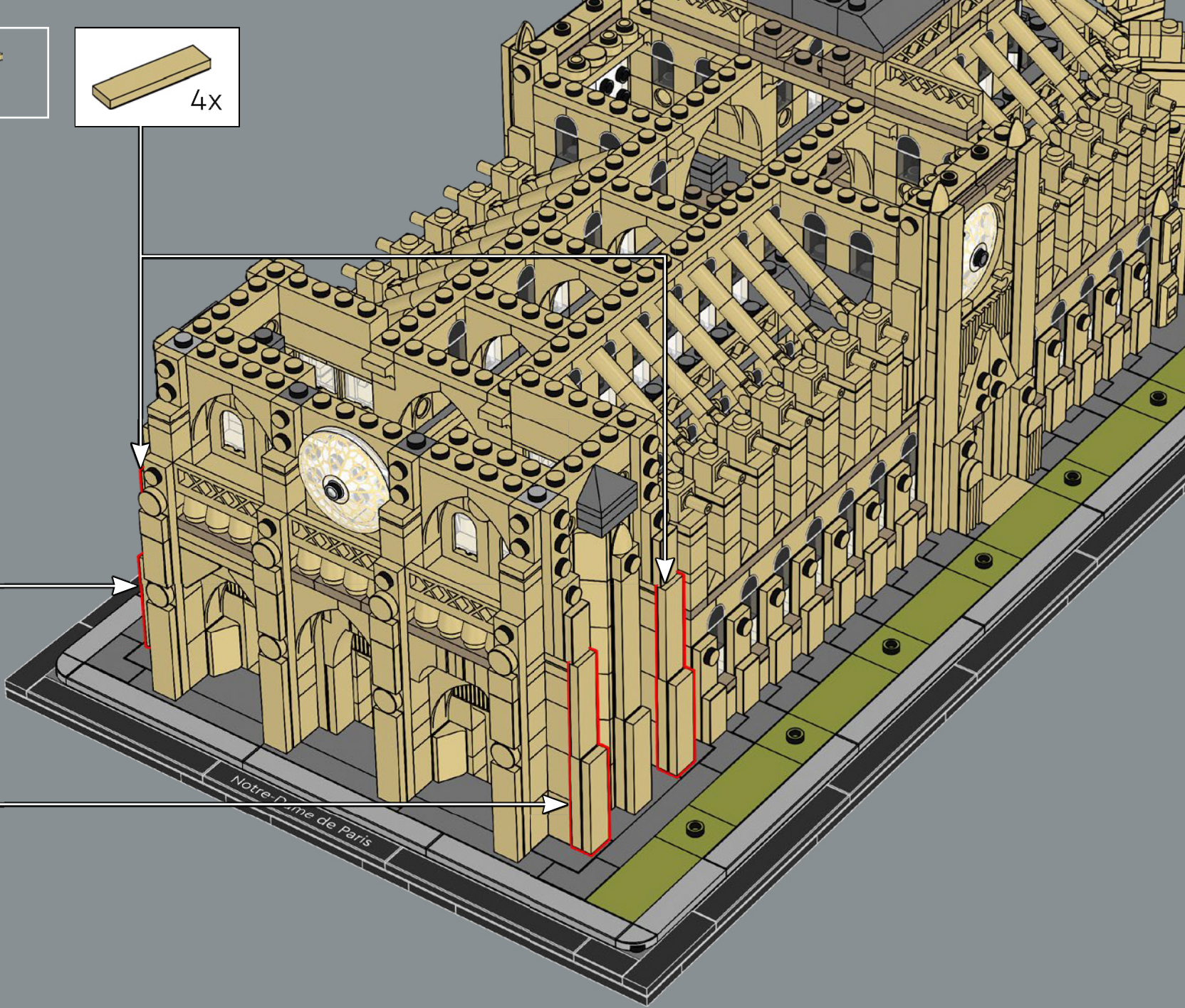
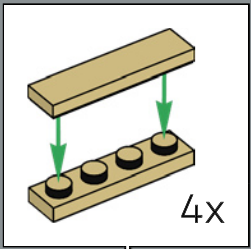

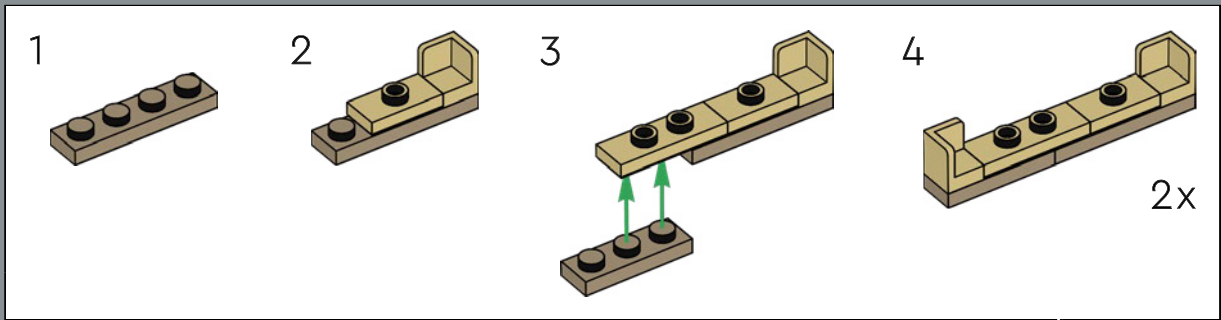
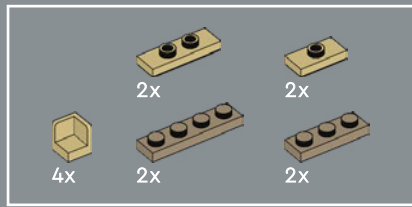

272

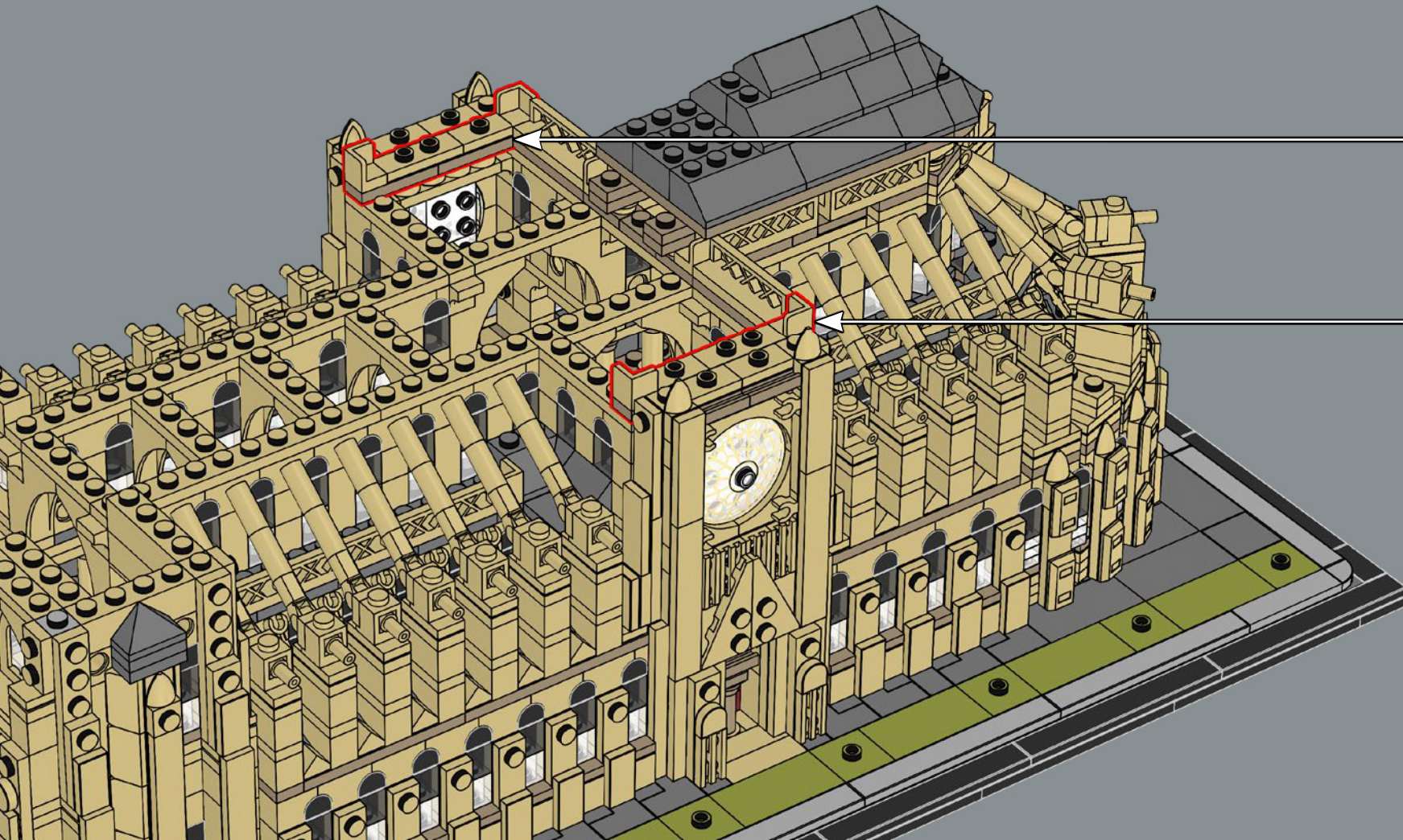

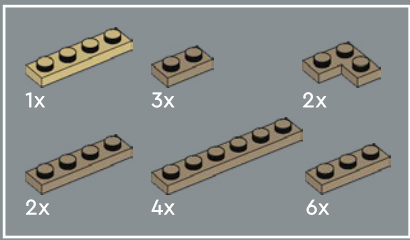

273

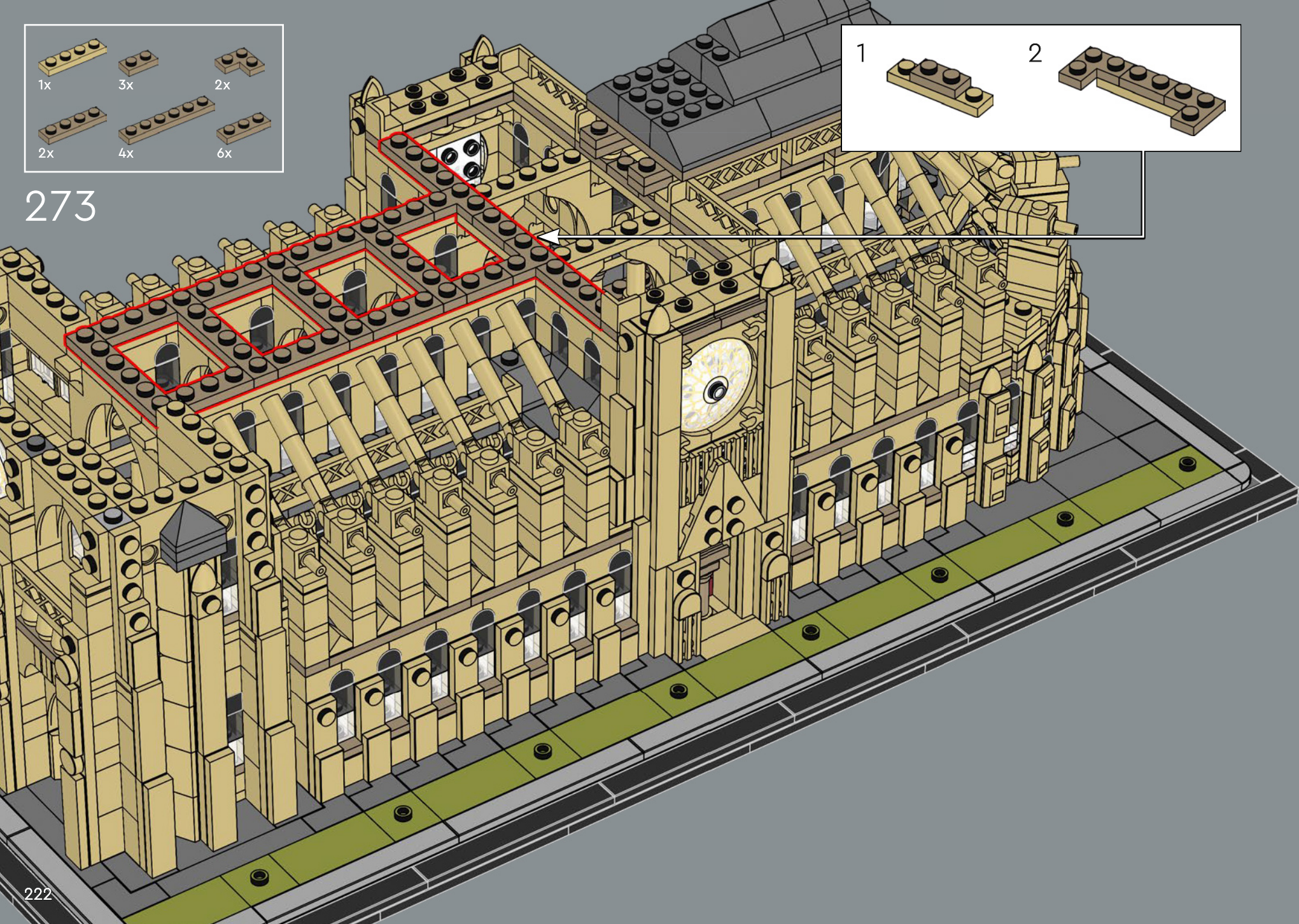
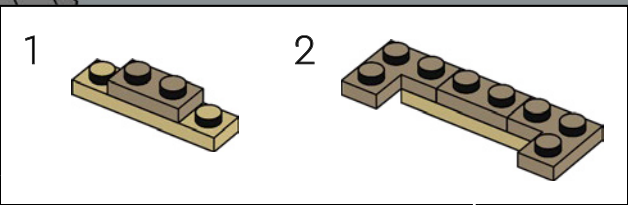

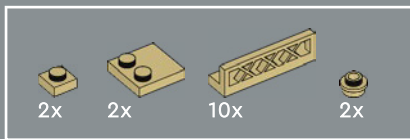

274

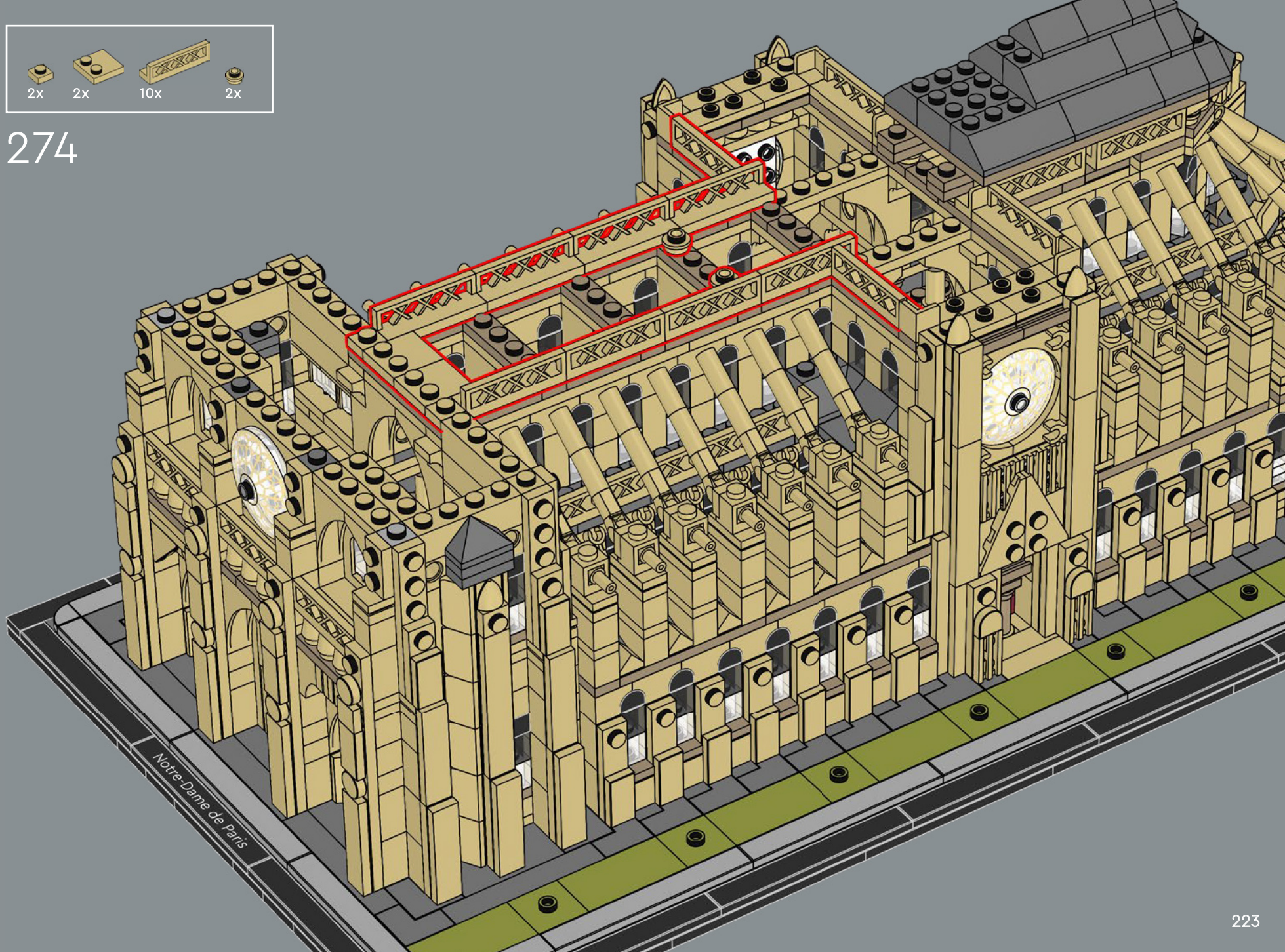



## LA TRASFORMAZIONE CONTINUA

✂ Nel 1245, tutte le torri furono completate. Mentre costruisci le torri, puoi provare alcuni dei meccanismi interni del campanile della cattedrale e della sovrastruttura che sostiene le leggendarie campane. Nel corso dei cinque secoli successivi, la cattedrale cominciò a mostrare i primi segni di decadimento. Nuove generazioni di architetti furono incaricate di apportare modifiche, riparazioni e aggiunte, come una guglia di legno ricoperta di piombo costruita sopra la crociera. Nel 1300, al perimetro del coro furono aggiunte le cappelle.





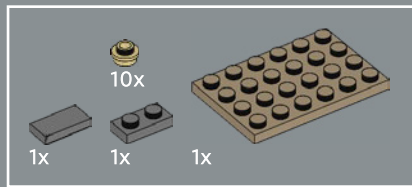

275

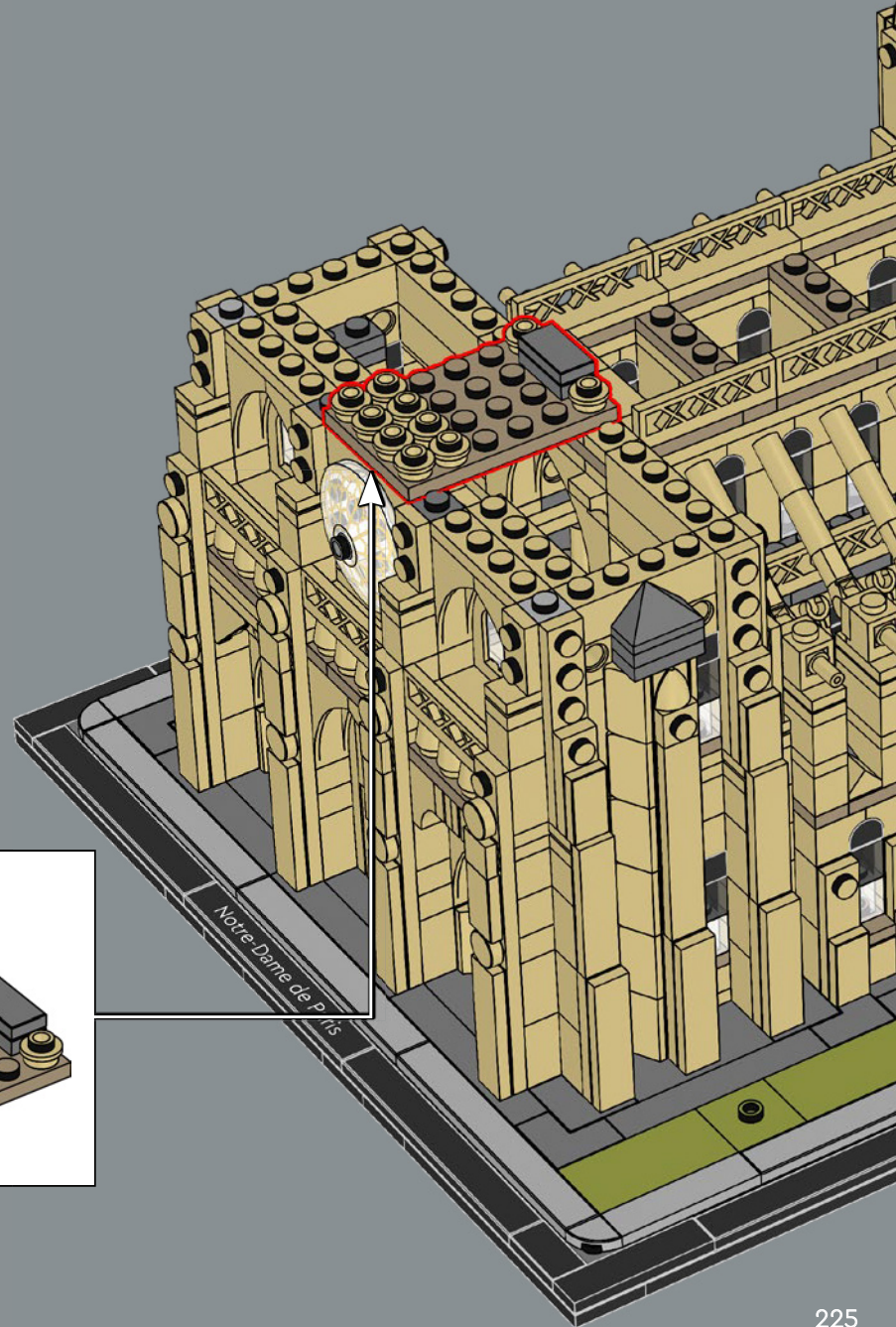
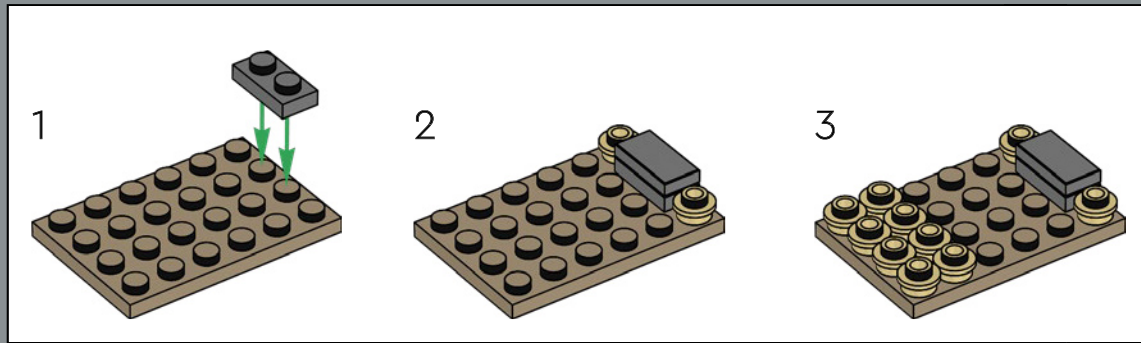

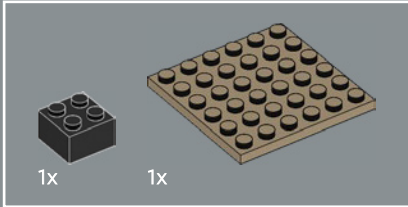
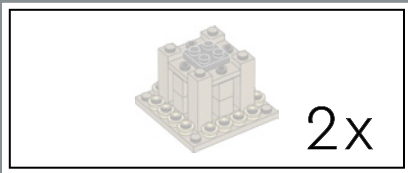

276

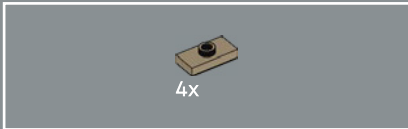
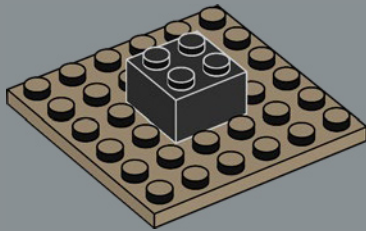

277

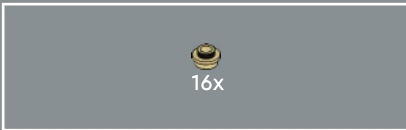
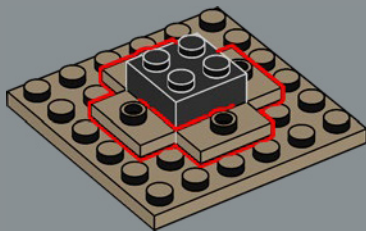

278

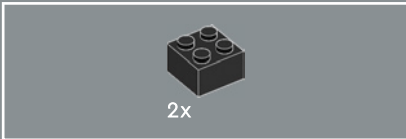
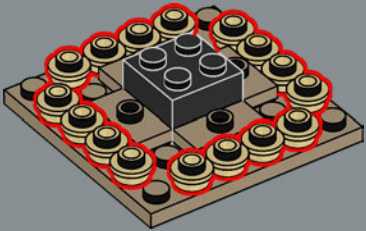

279

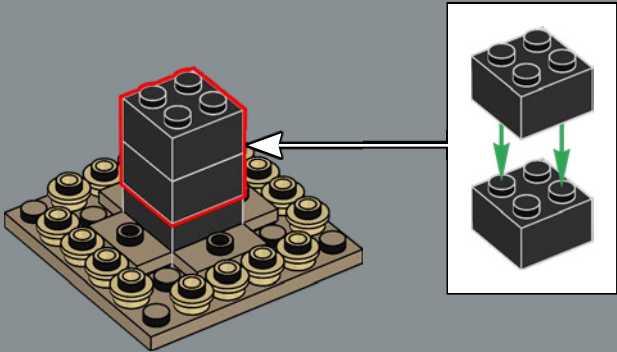



280

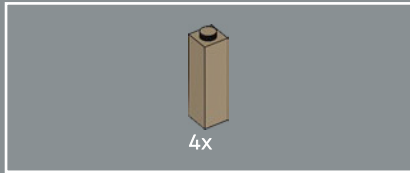
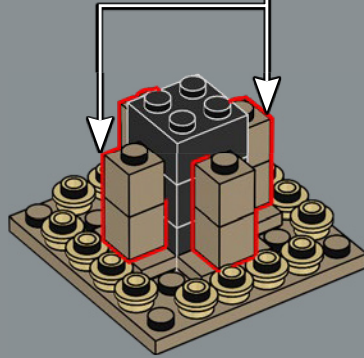
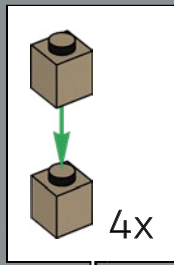

281

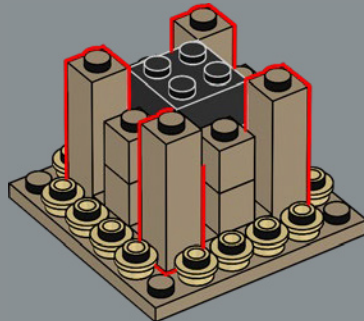

282

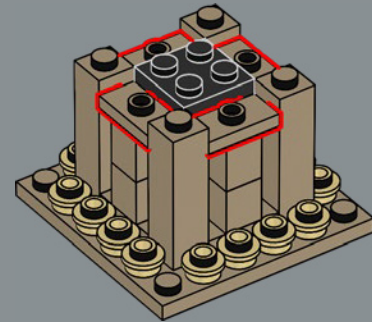

2x

283



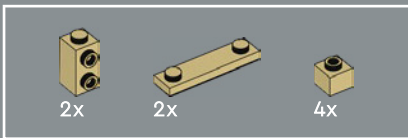

284

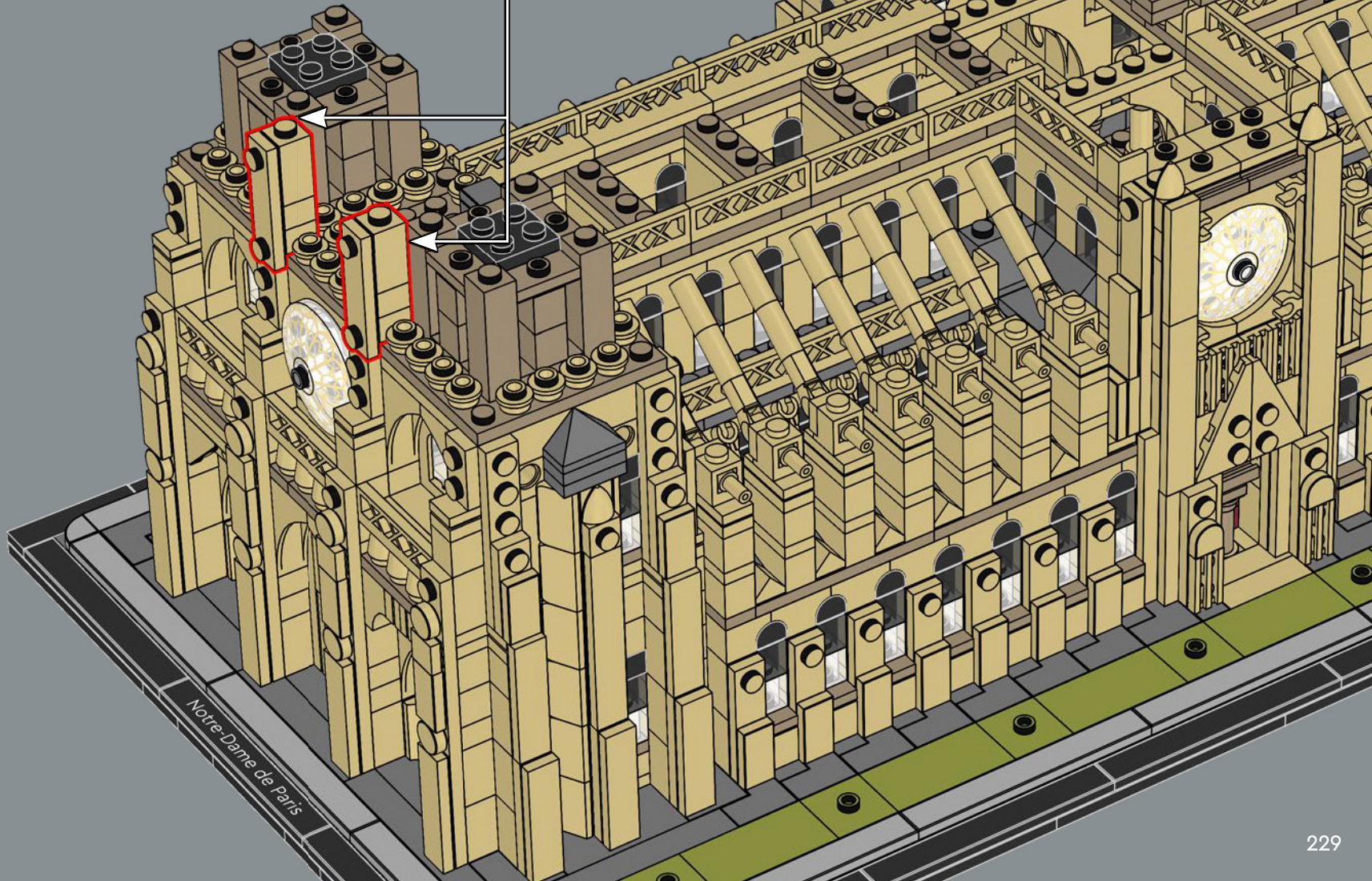
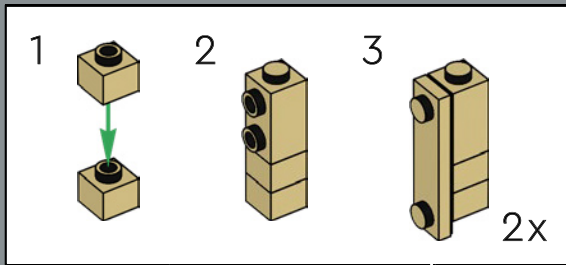



285

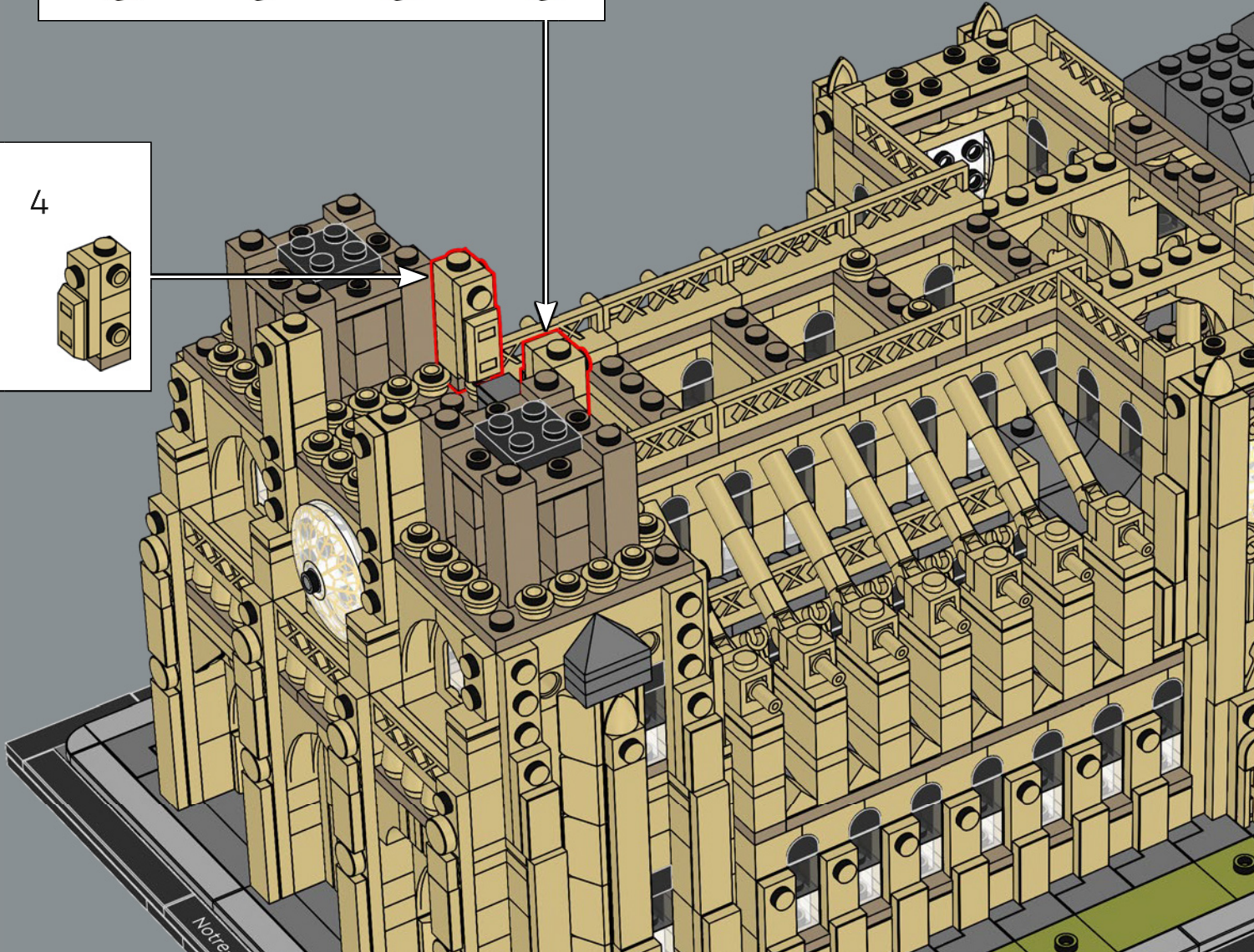
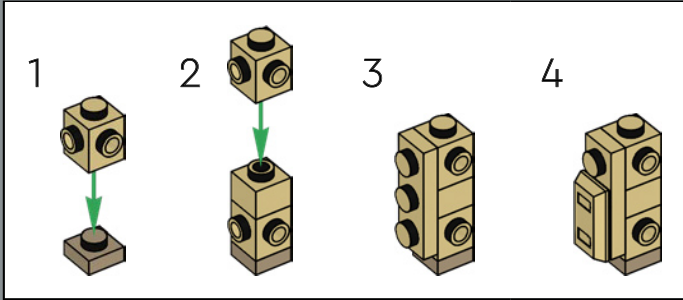
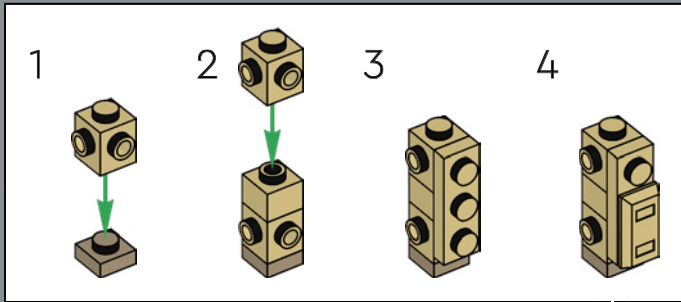

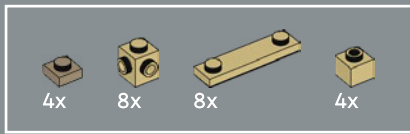

286

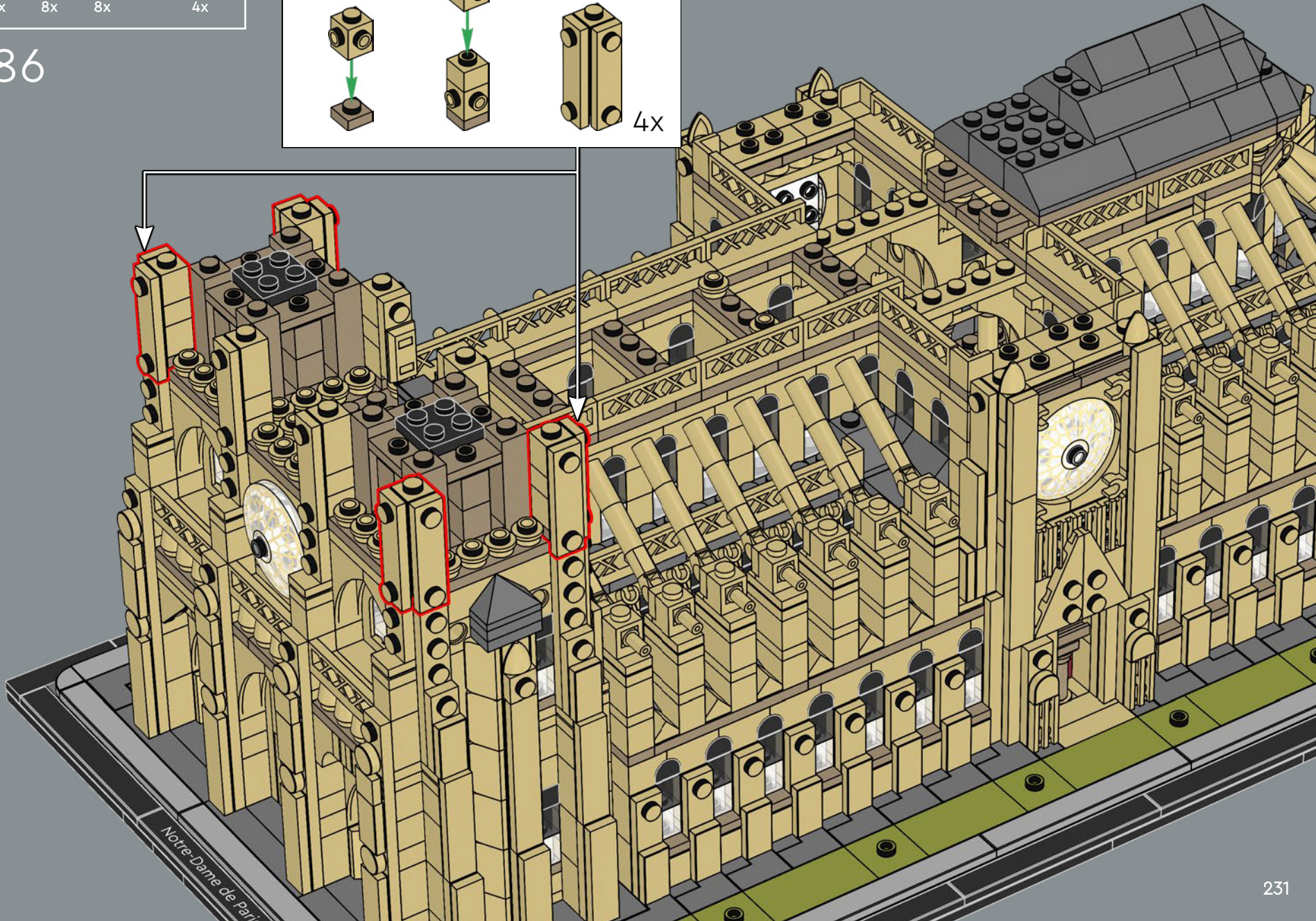
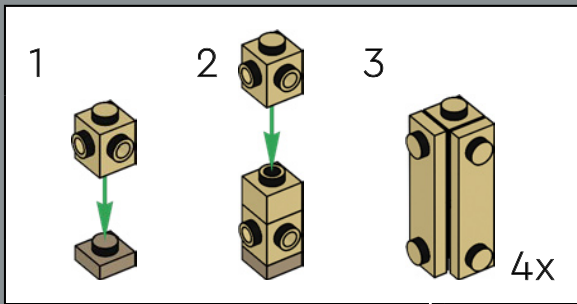



287

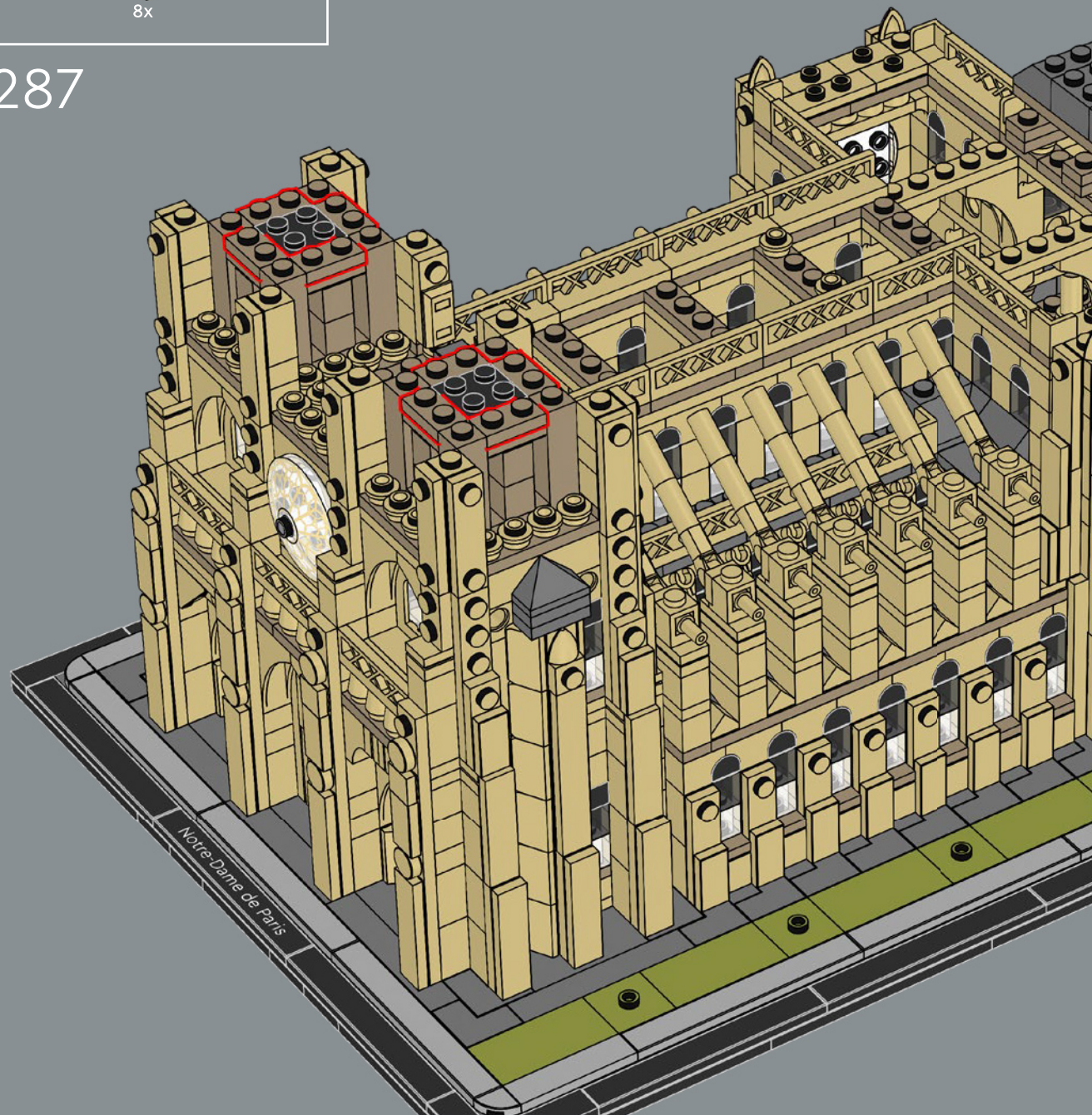





288

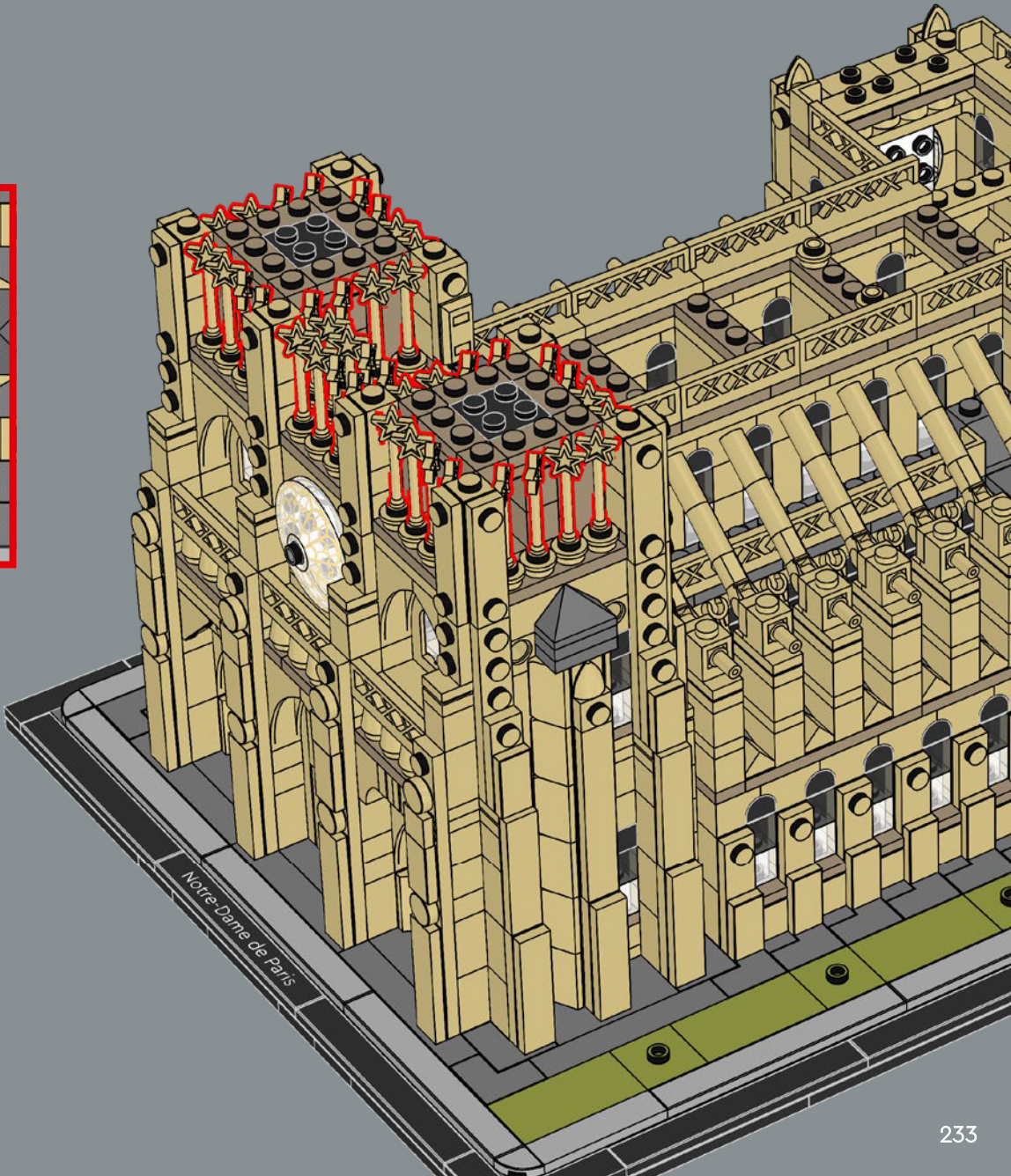
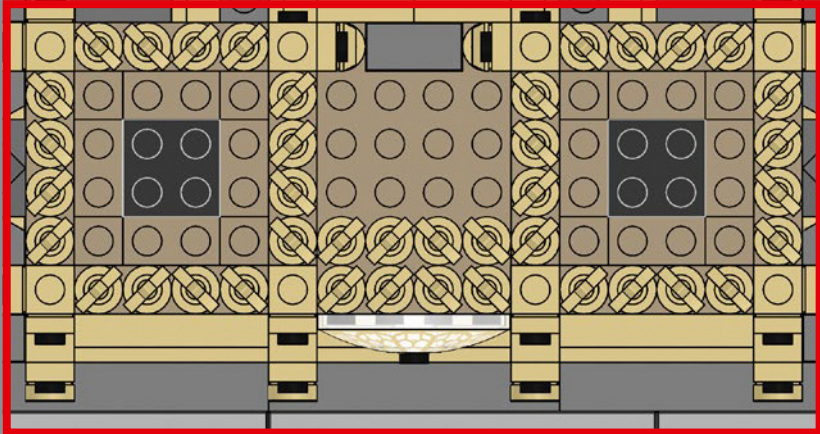

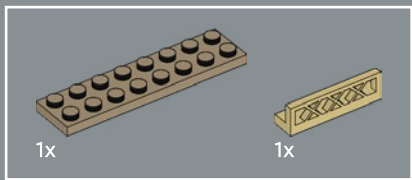

289

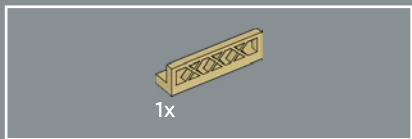
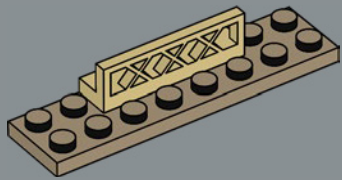

290

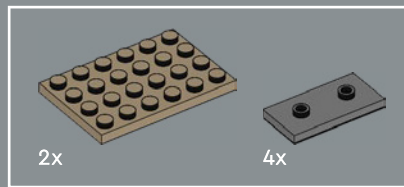
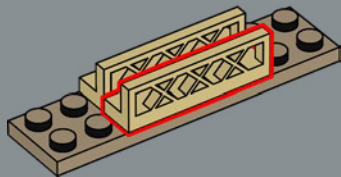

291

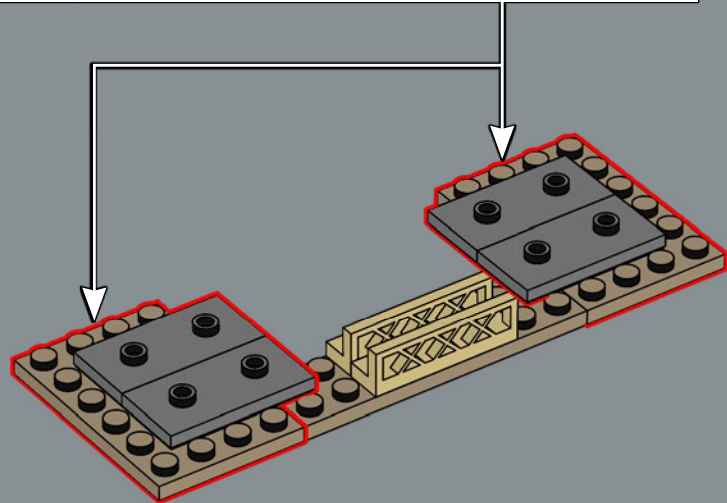
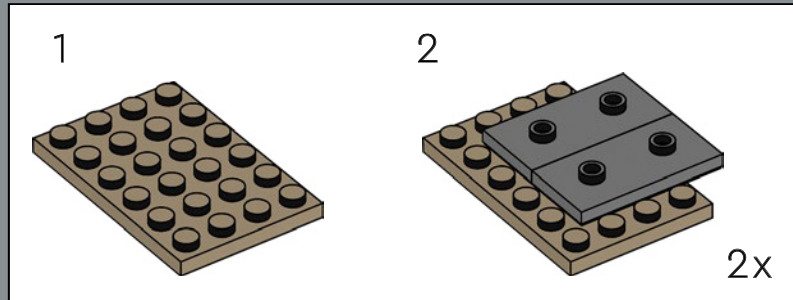

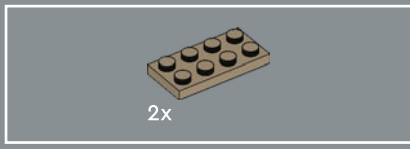

292

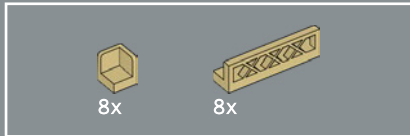
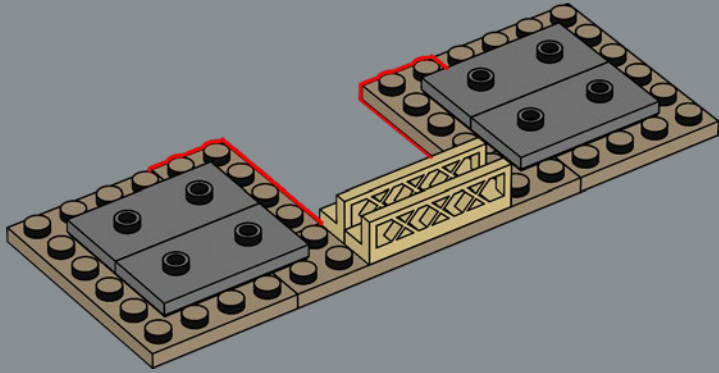

293

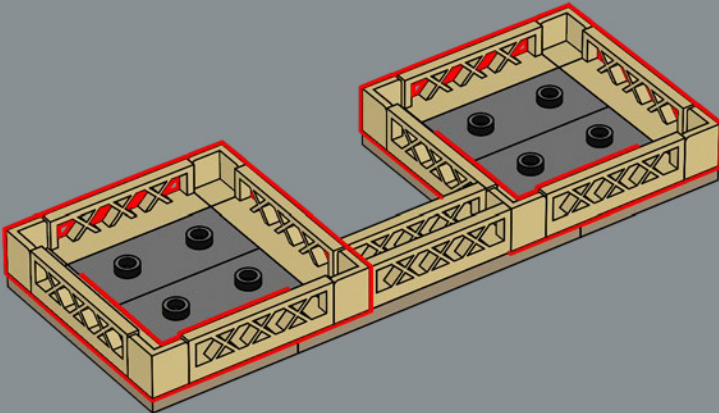

294

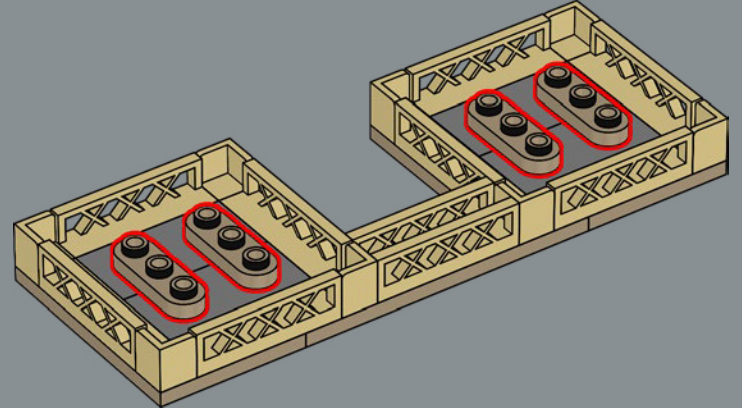

295

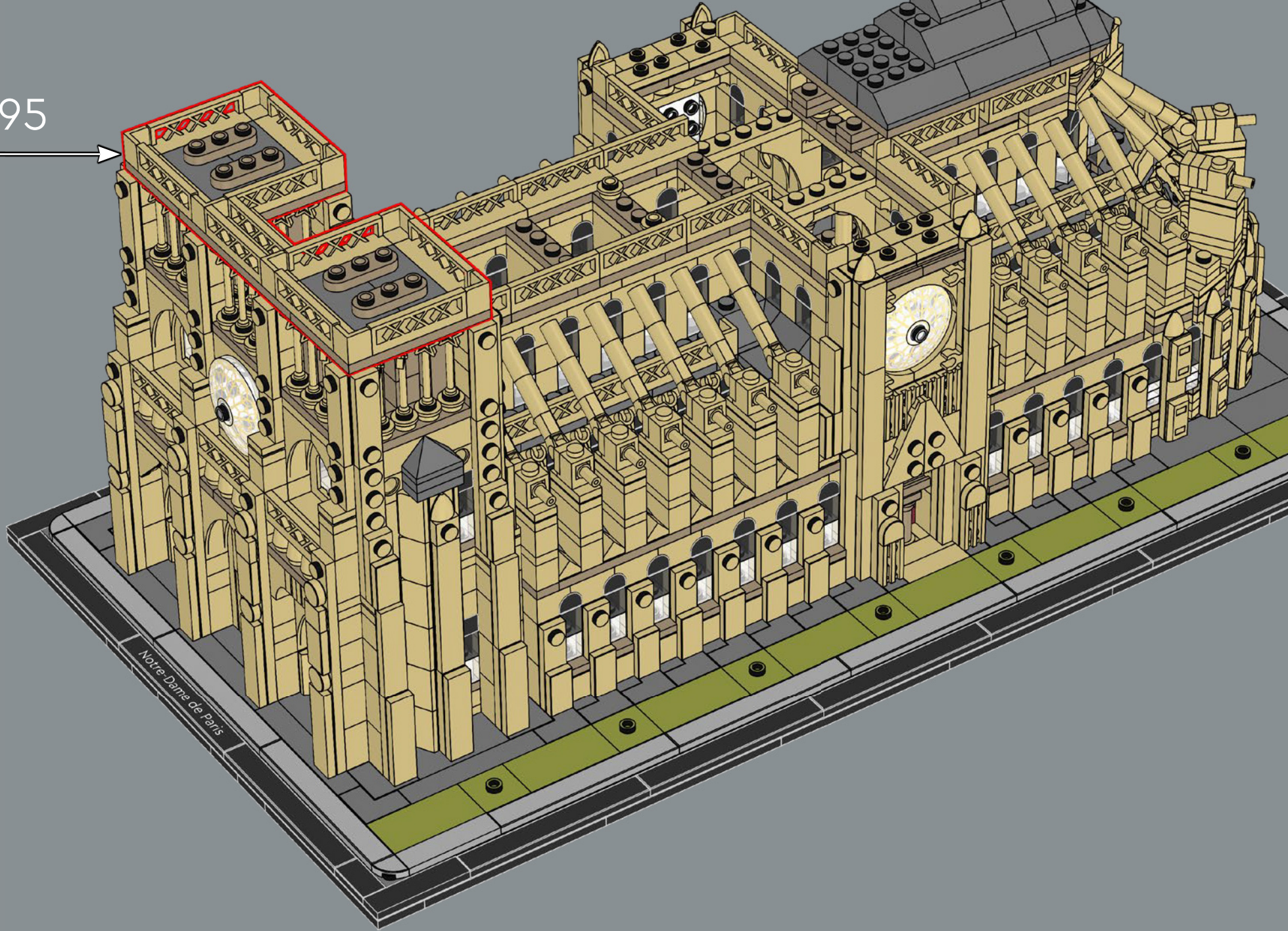

*Notre-Dame de Paris*

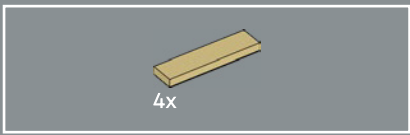

296

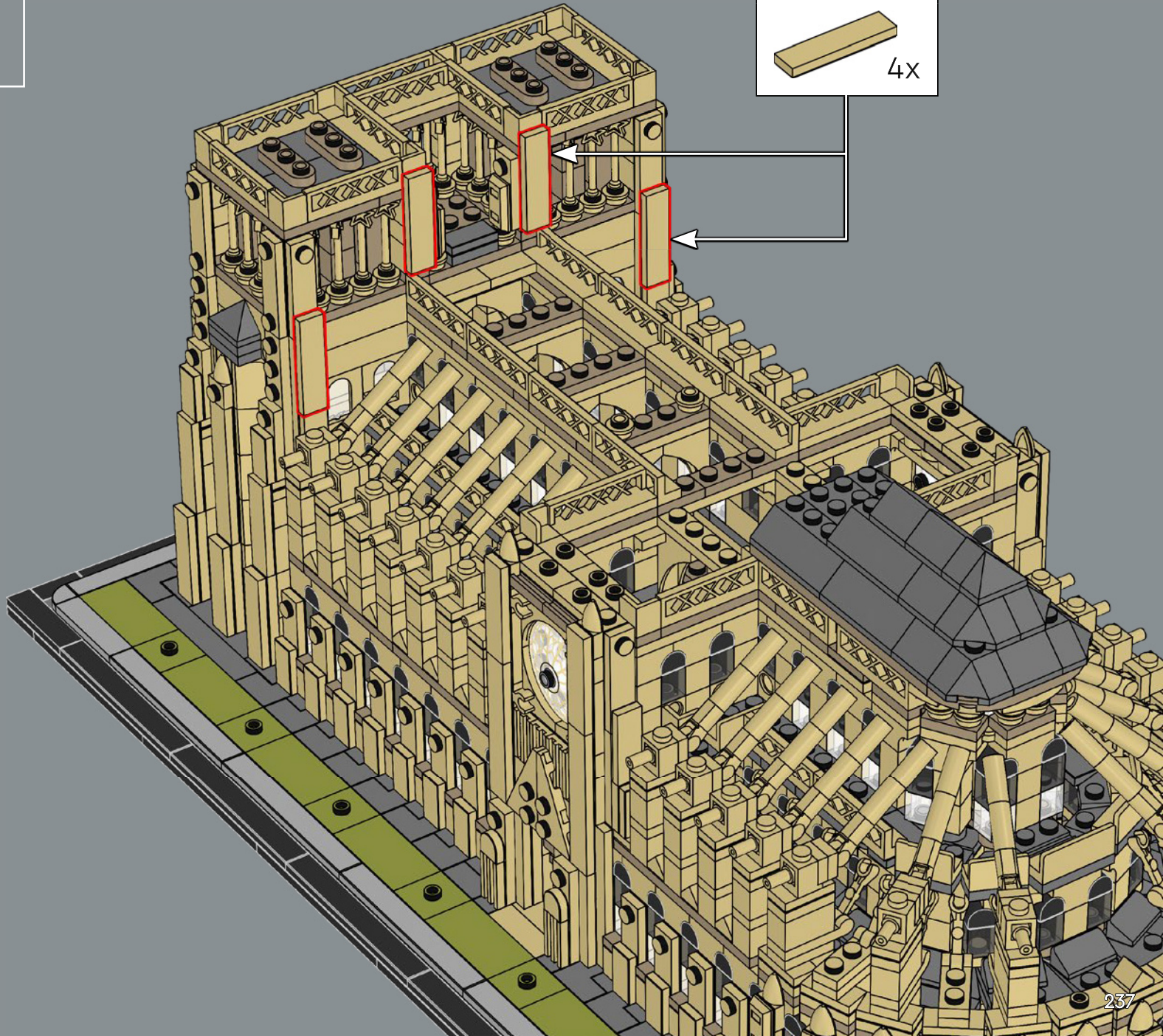
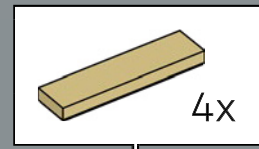



297

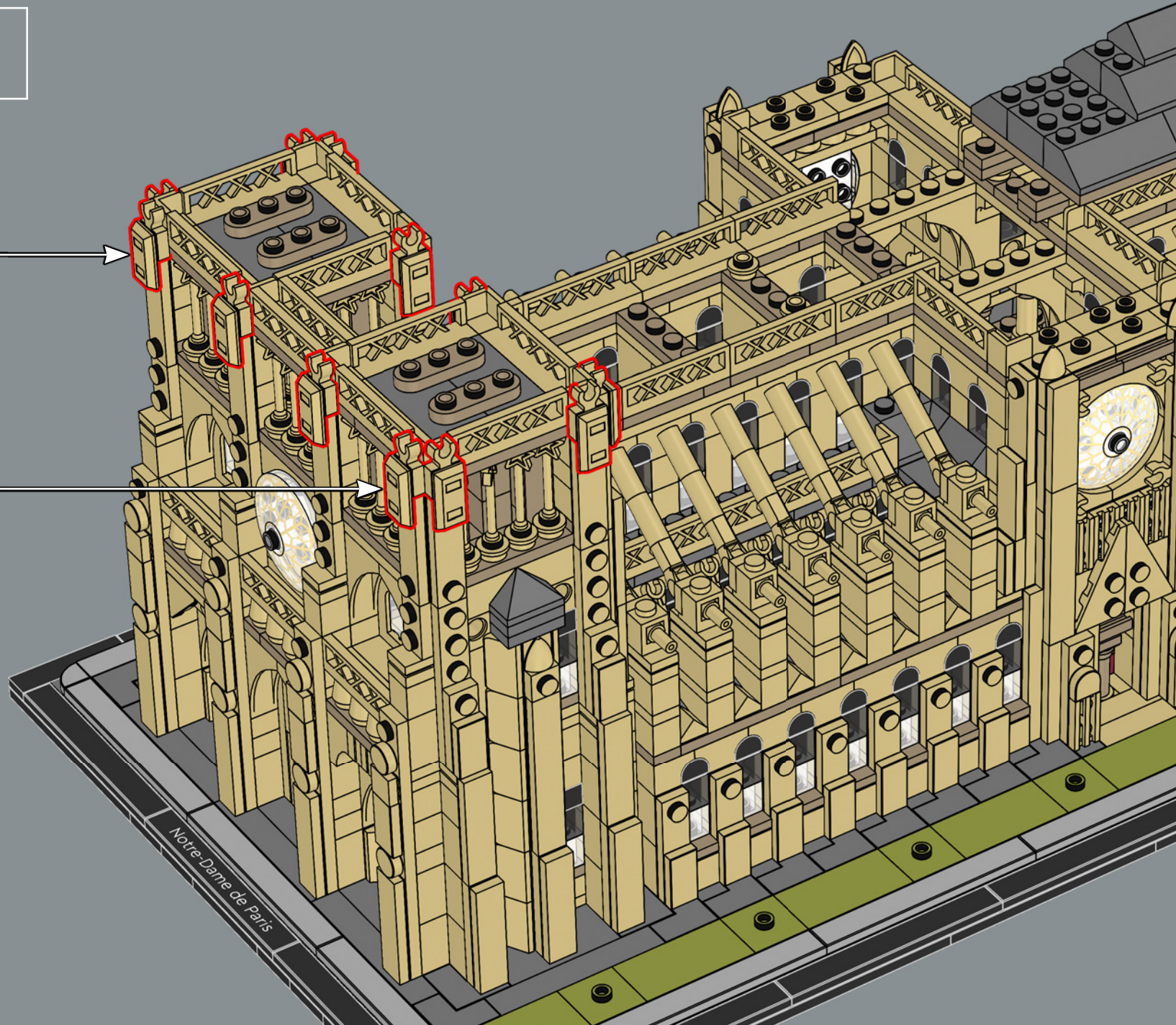
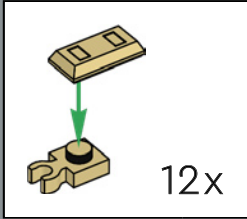

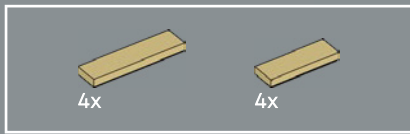

298

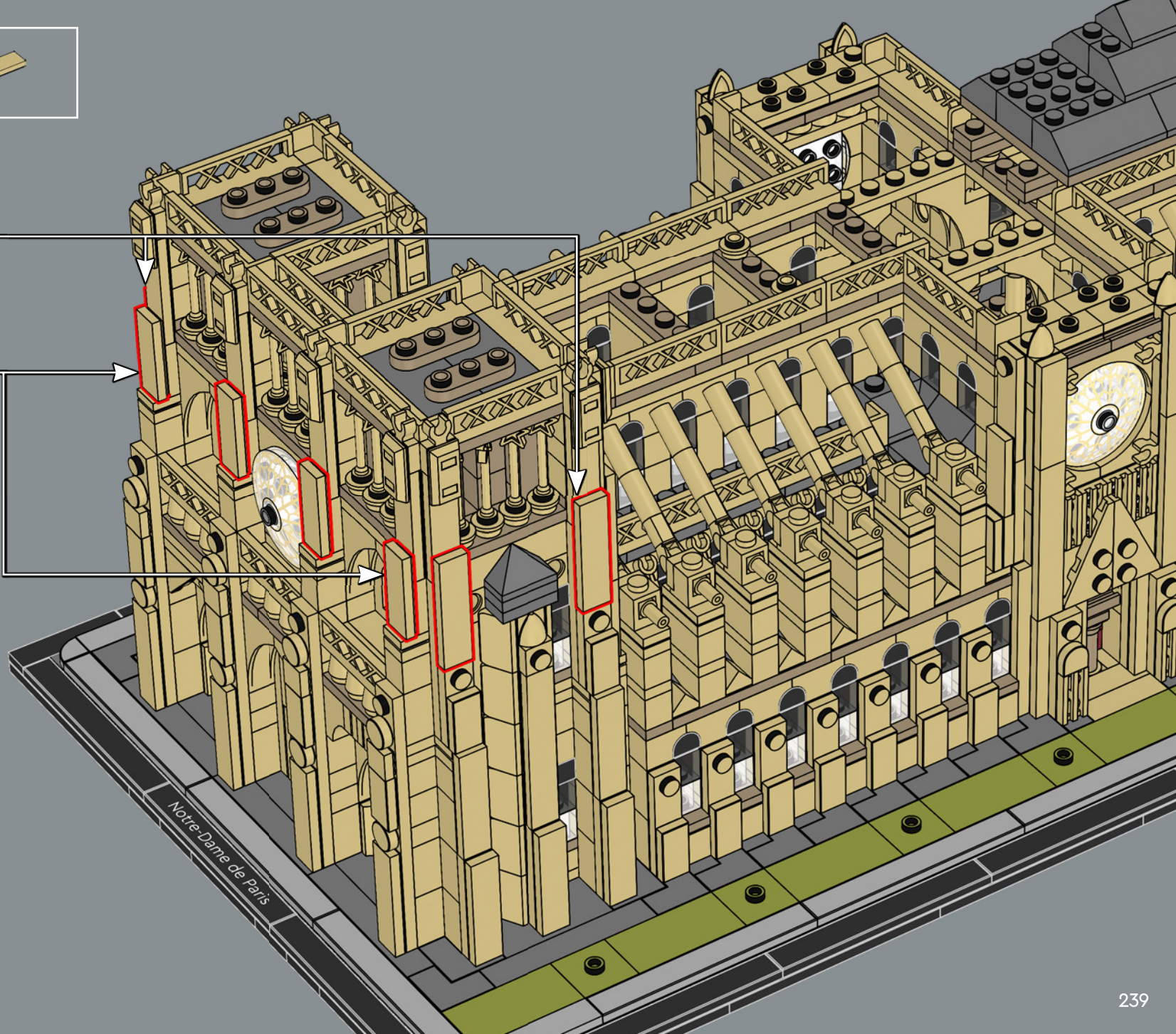
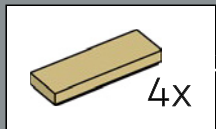
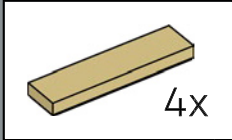



4x

299



4x

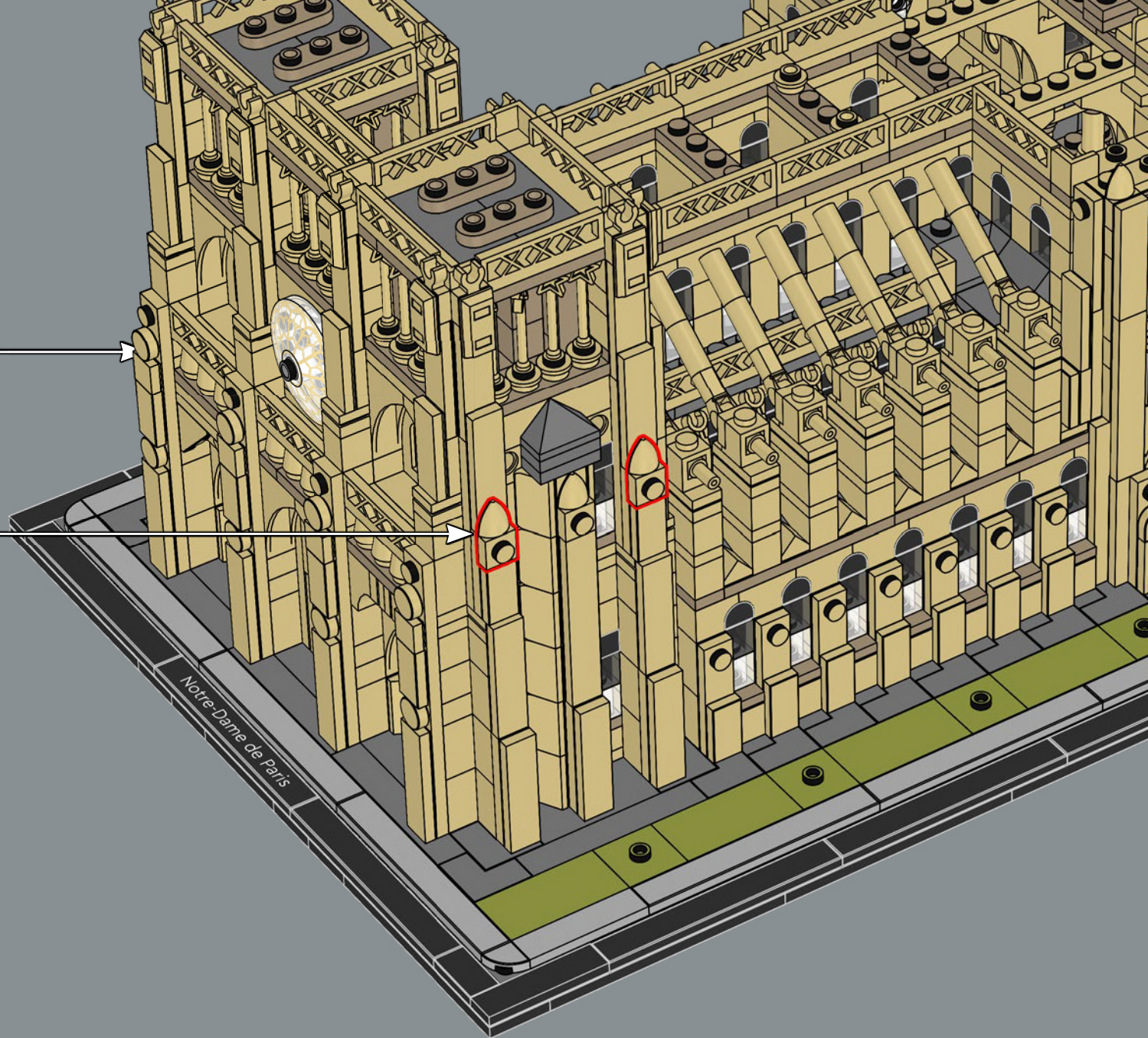



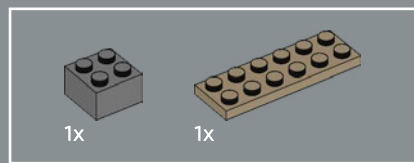
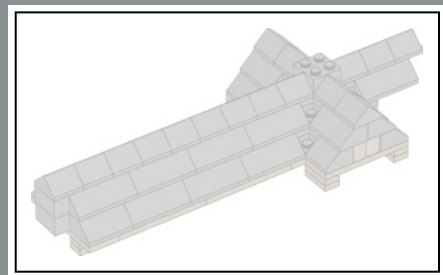

300

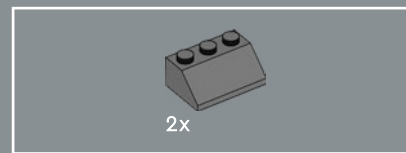
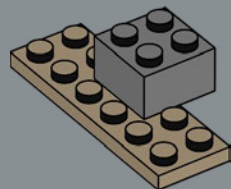

301

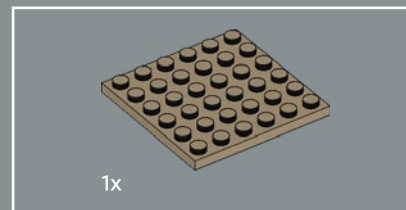
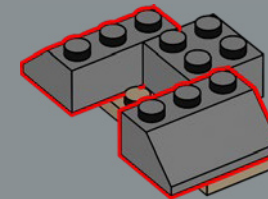

302

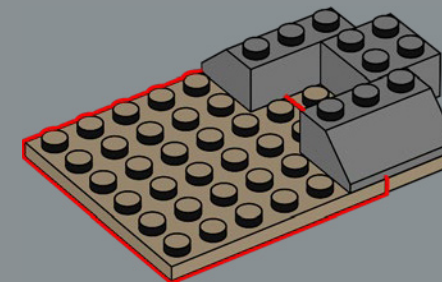

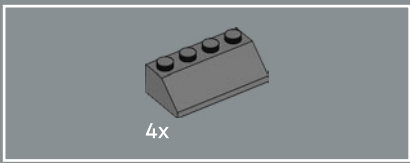

303

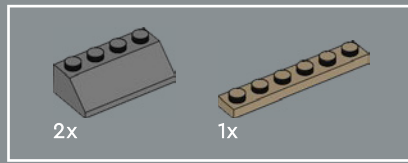
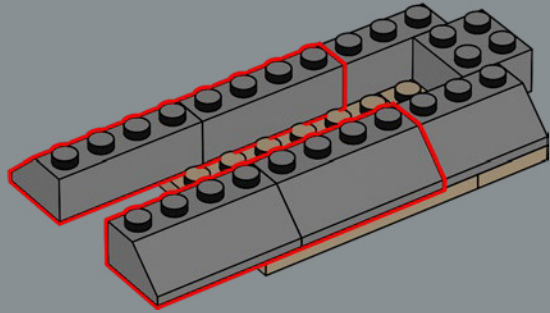

305

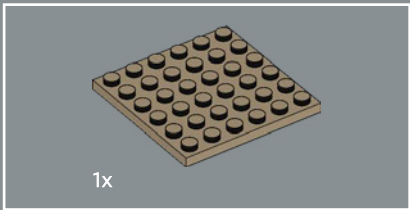
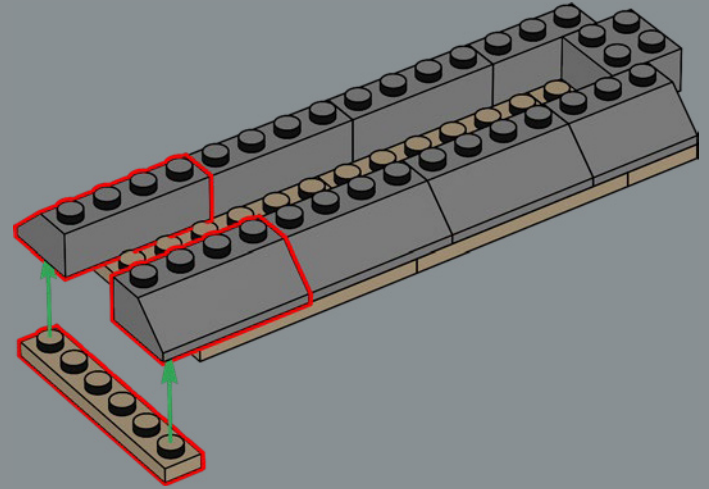

304

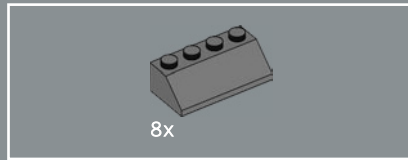
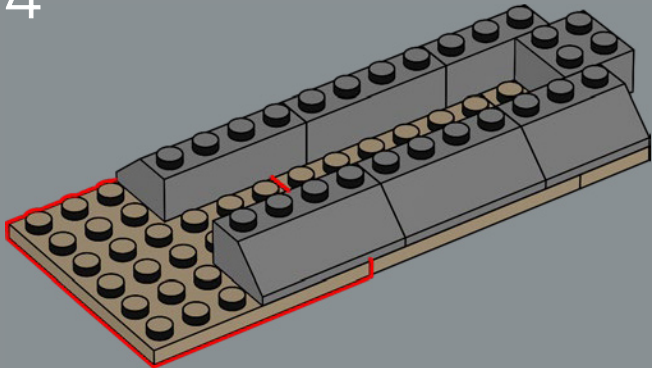

306

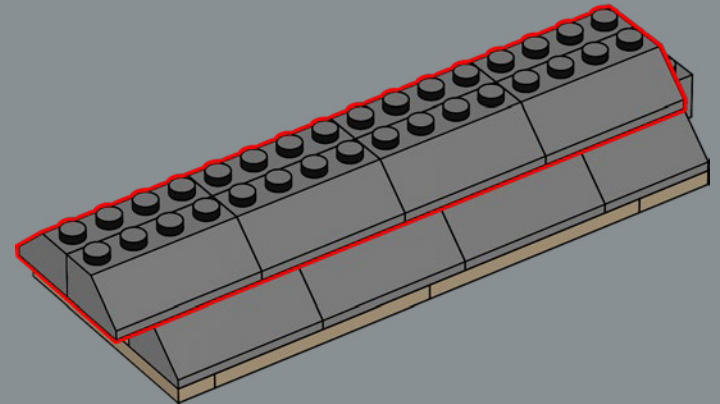

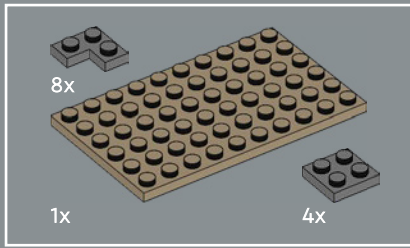

307

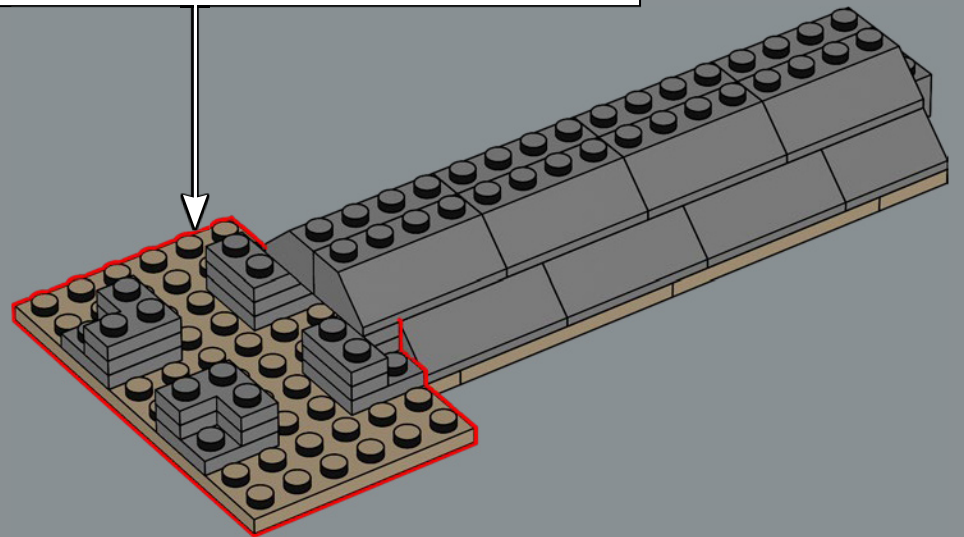
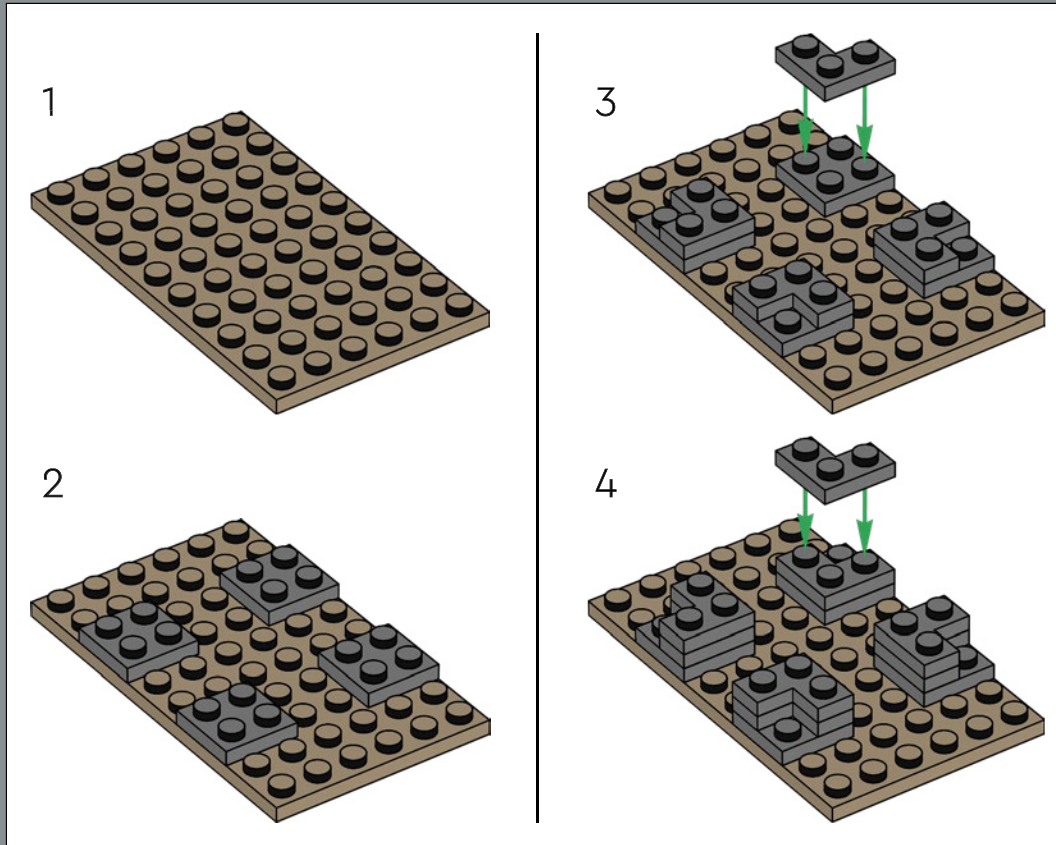

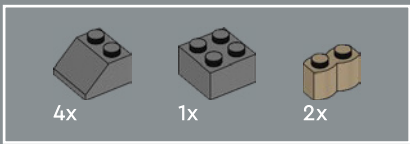

308

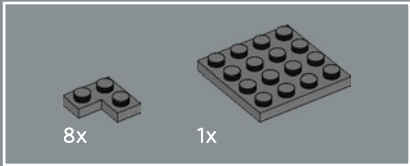
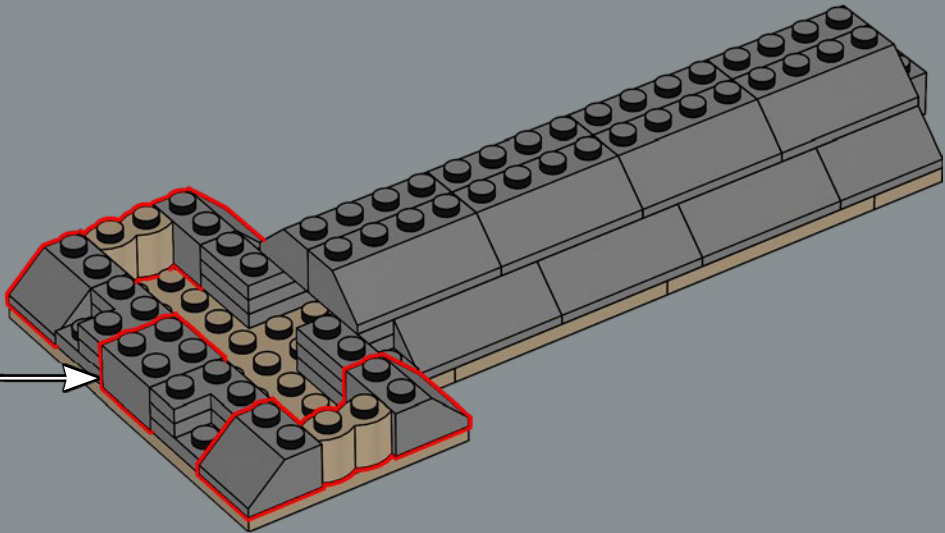
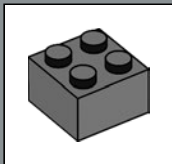

309

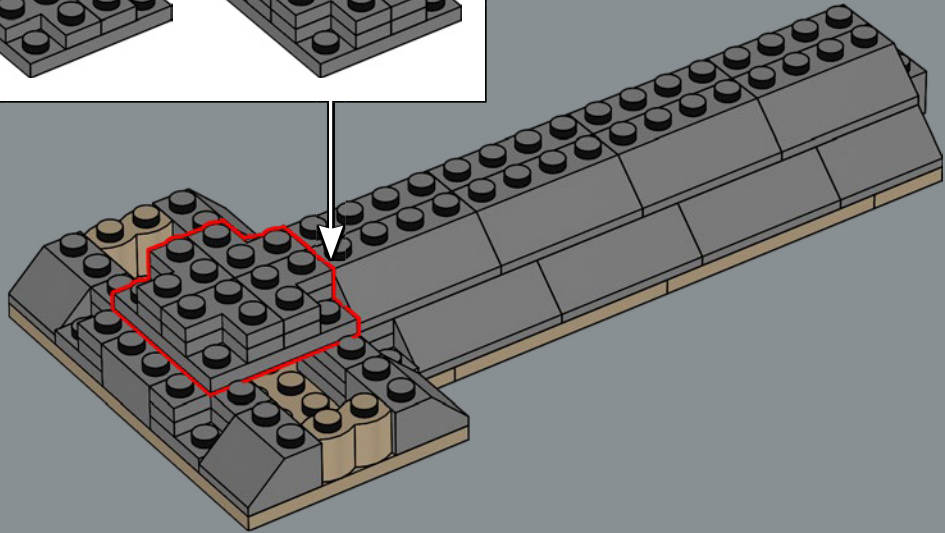
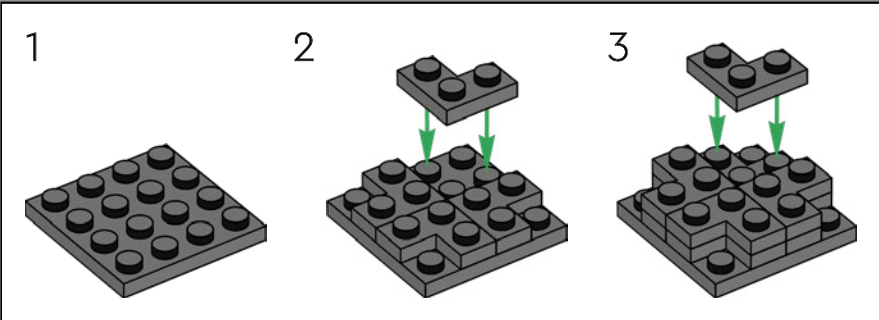

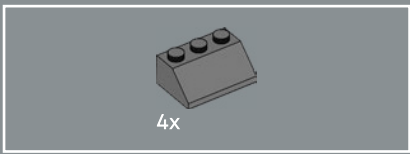

310

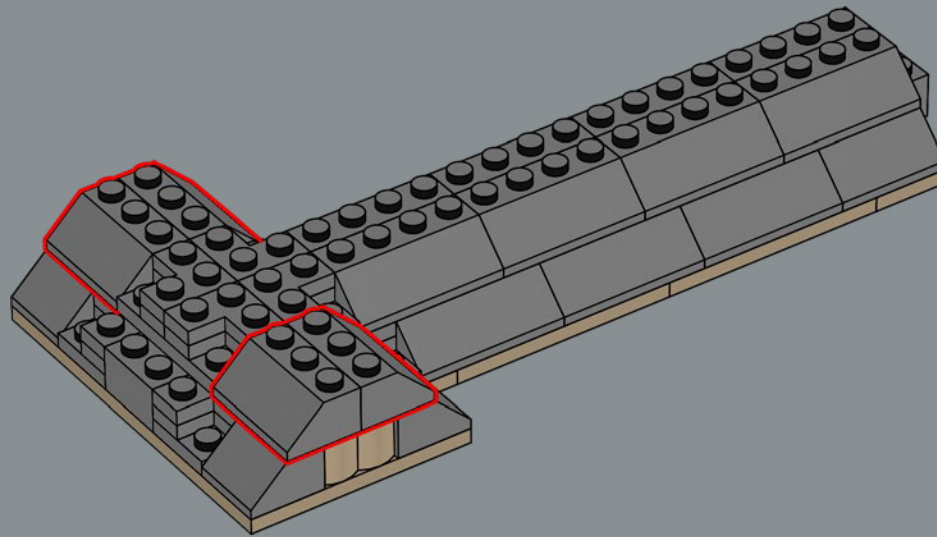

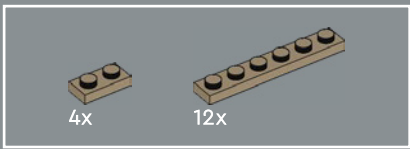

311

1

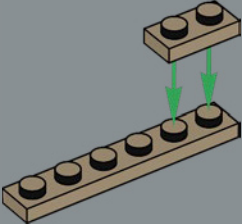

2

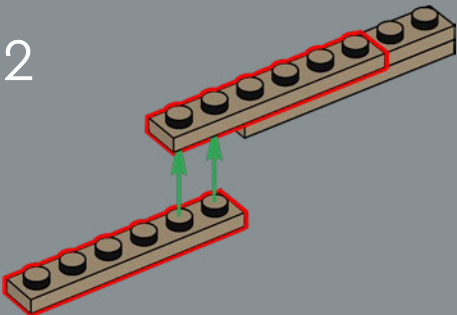

3

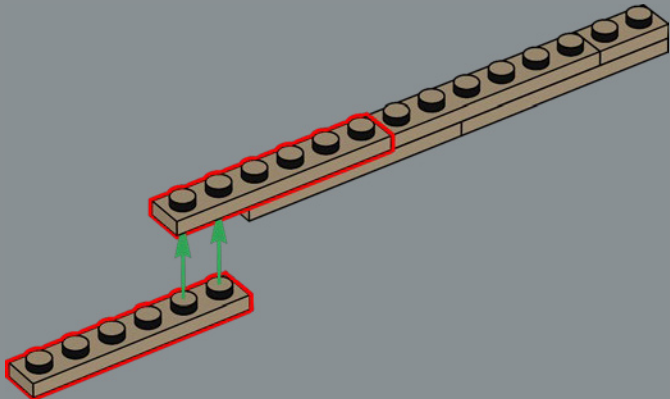

4

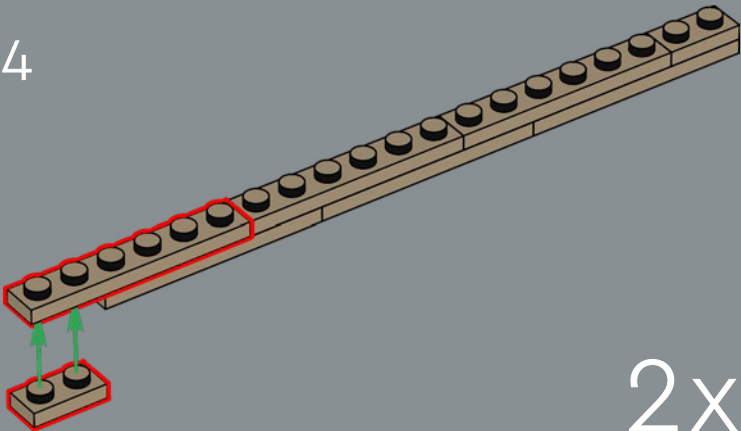

2x

Per la struttura in legno della cattedrale, fu usato legname proveniente da 1.300 querce, ovvero l'equivalente di 21 ettari (circa) di foresta!

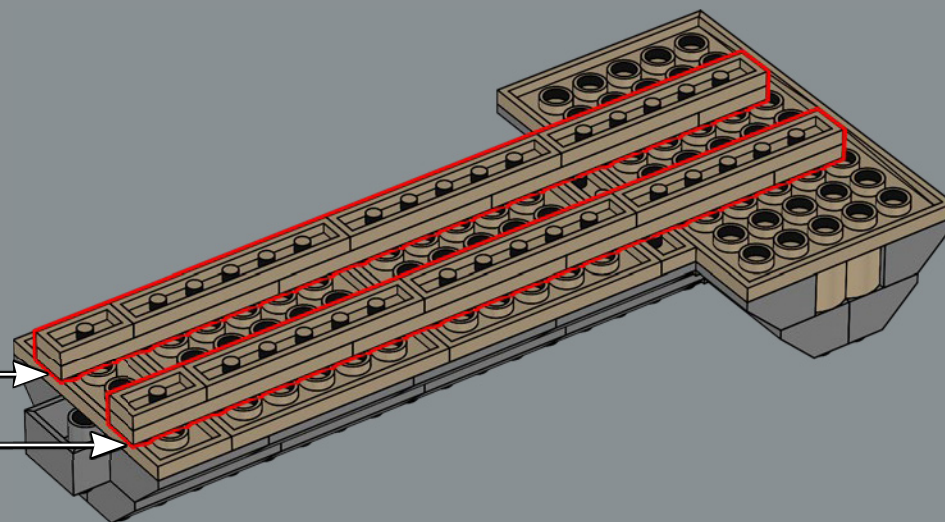



8x

312

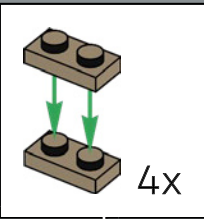

4x

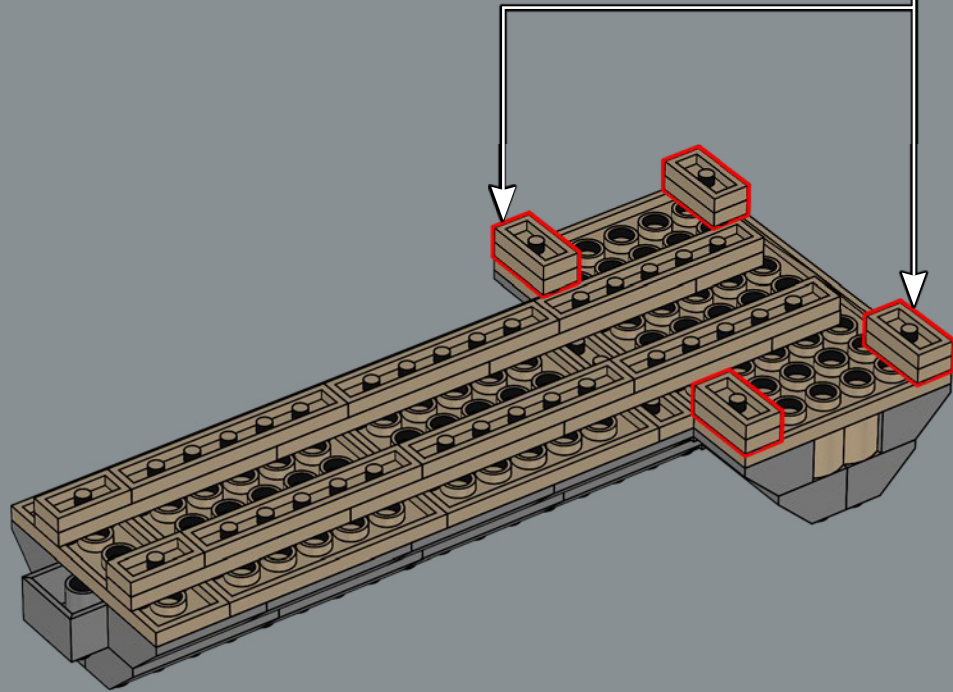



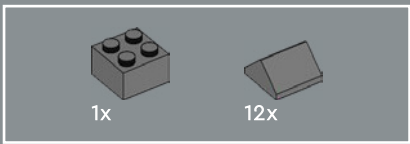

313

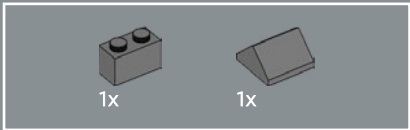
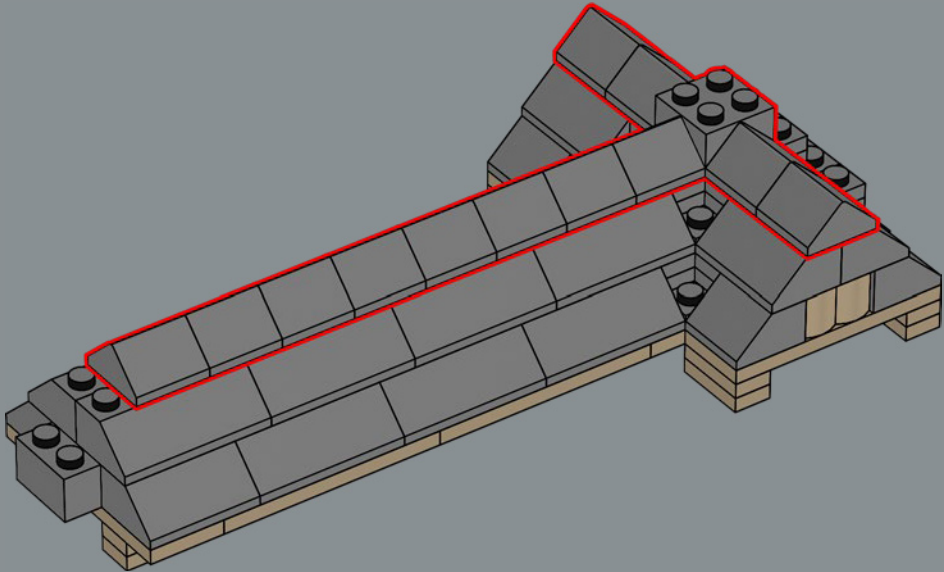

314

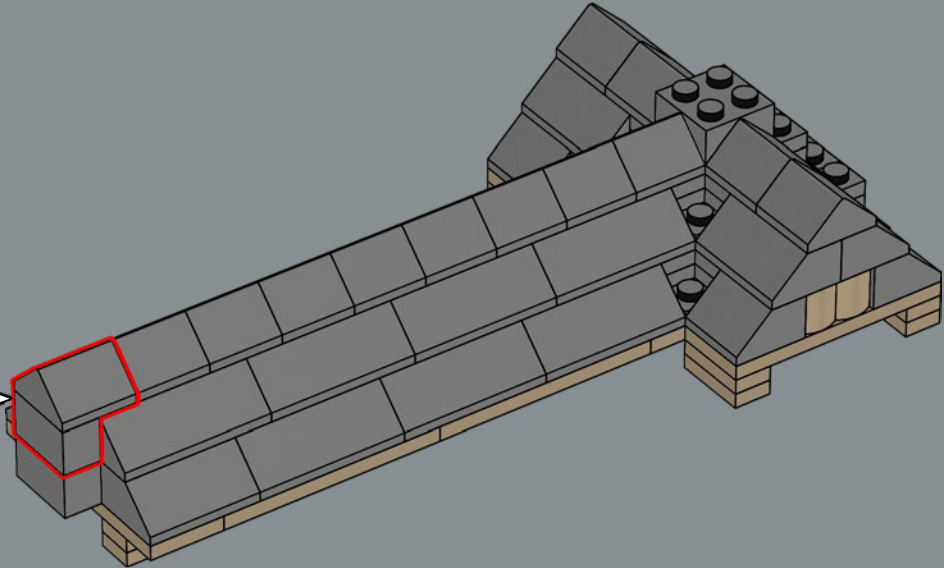
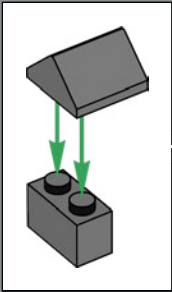

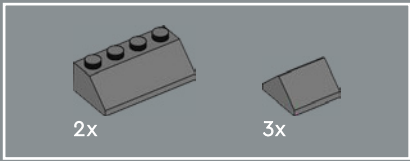

315

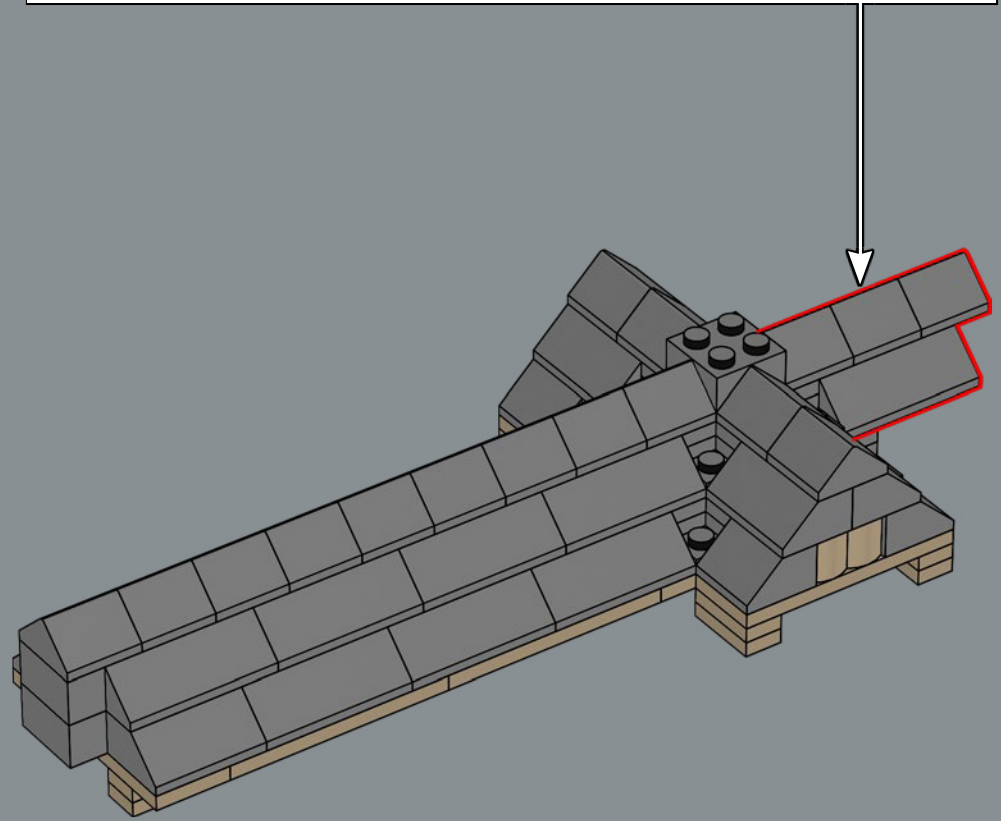
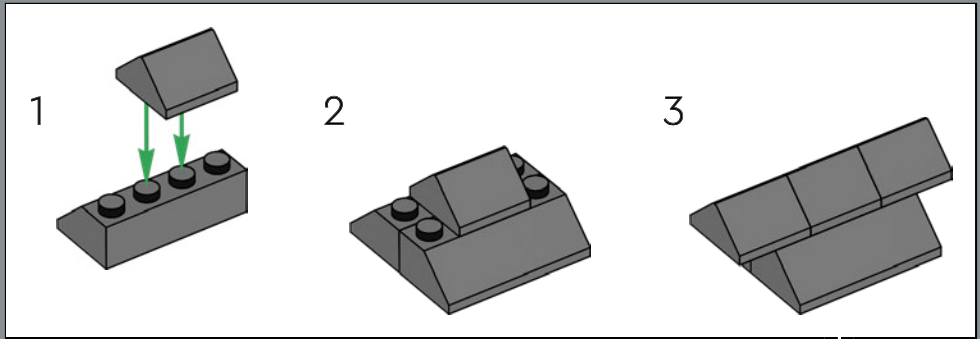

316

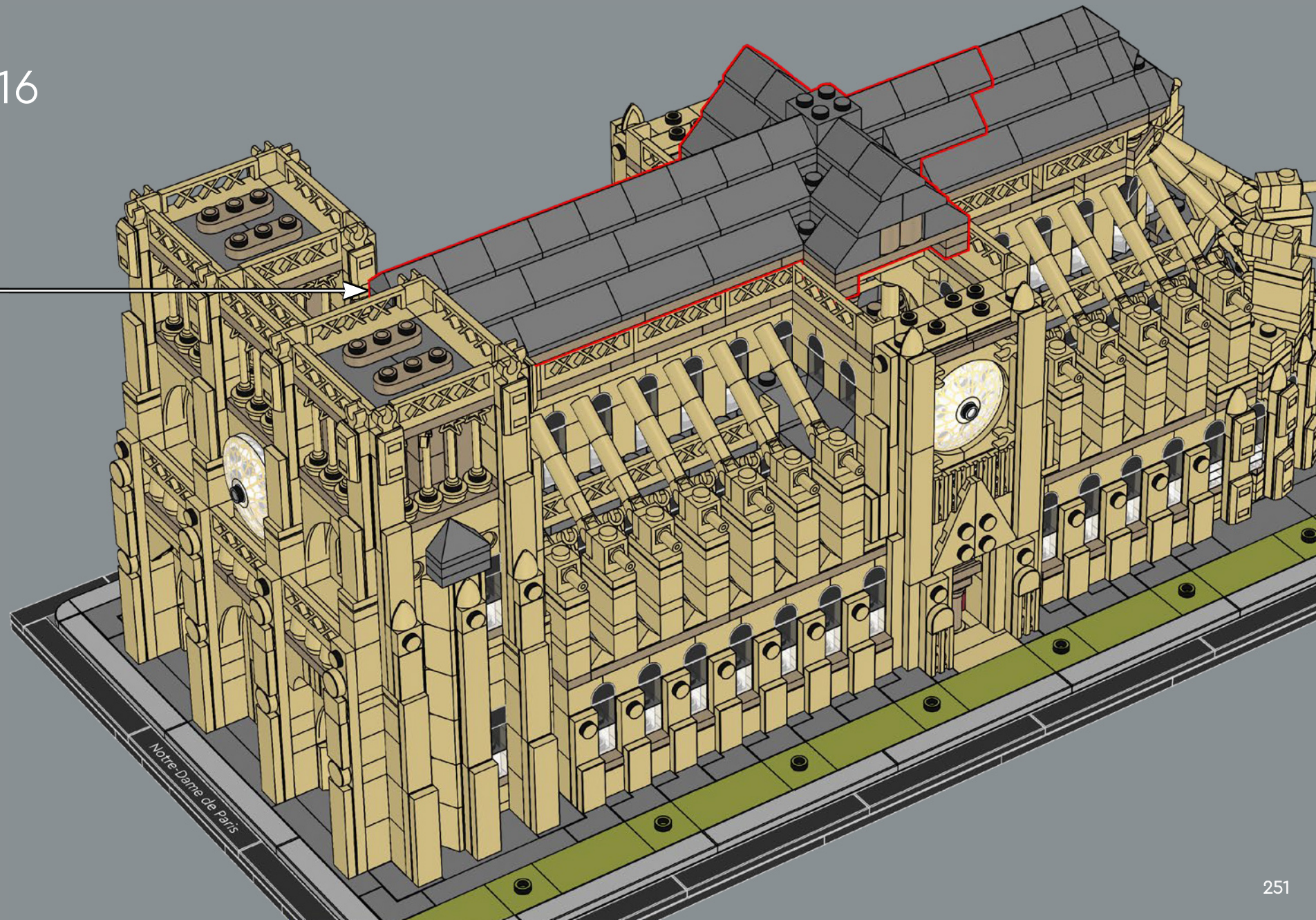

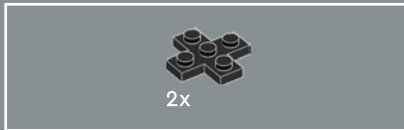
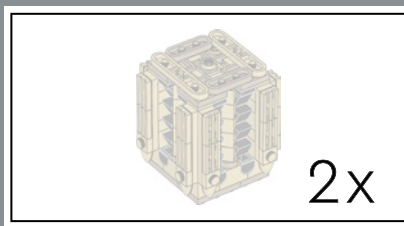

317

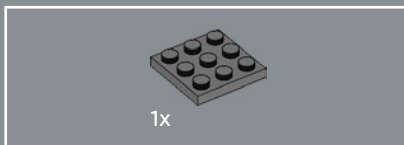
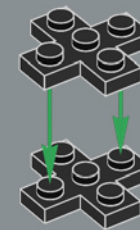

318

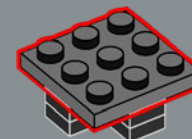

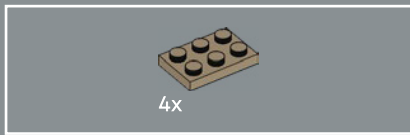

319

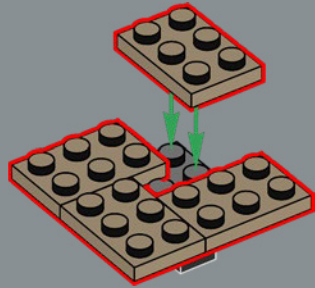

320

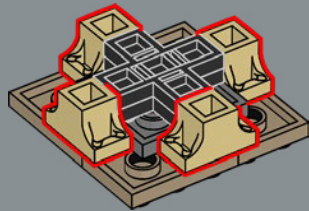

321

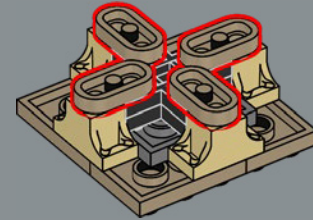

322

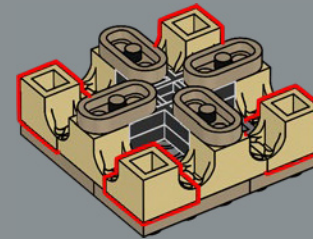



323

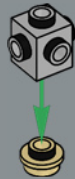

324

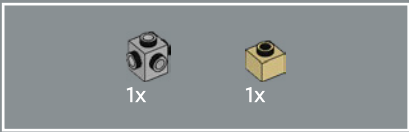

325

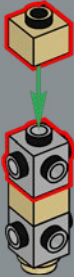

326



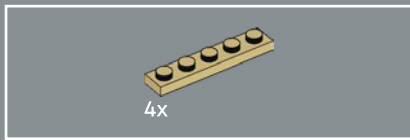

327

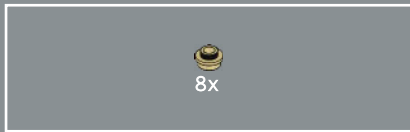

328

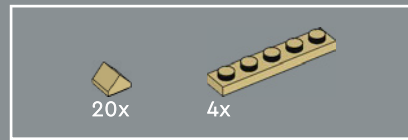
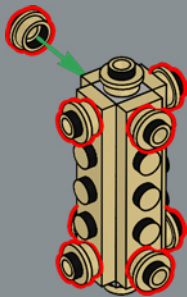

329

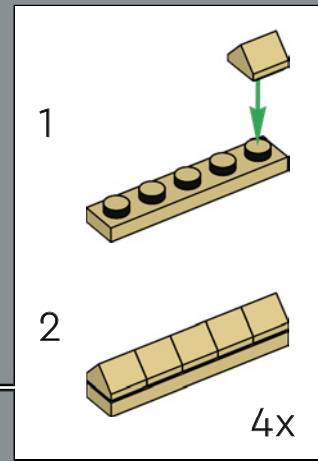
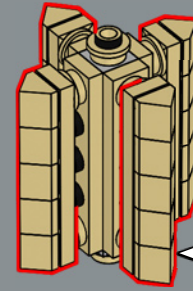

330

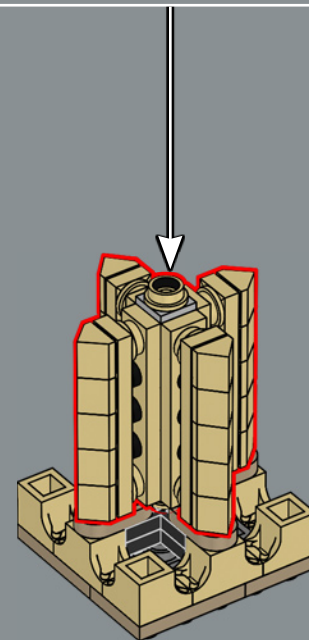

2x



331

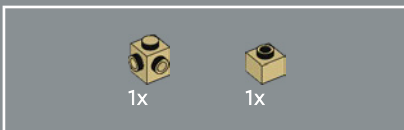

332

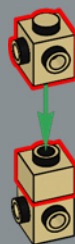

333





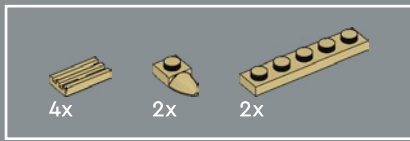

334

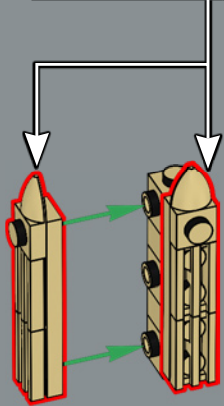
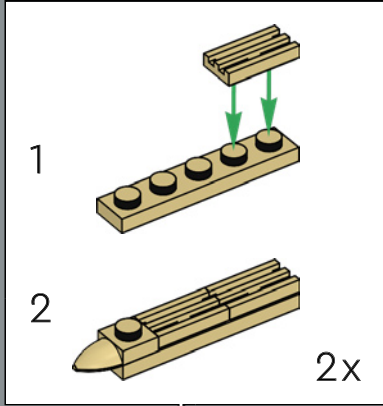

335

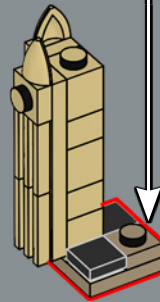
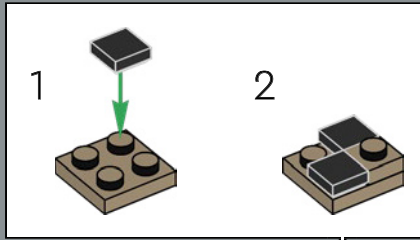

336

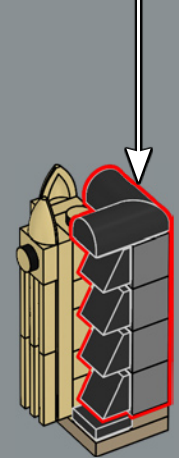
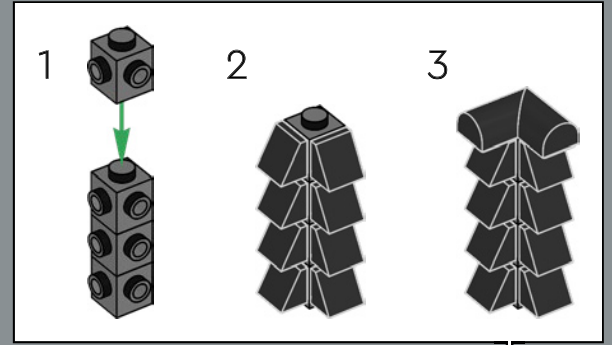

4x

337

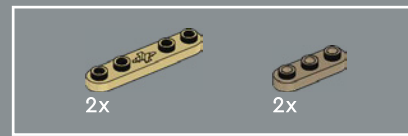
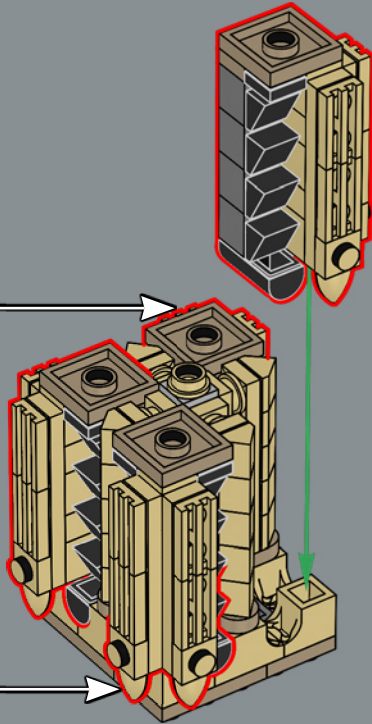

338

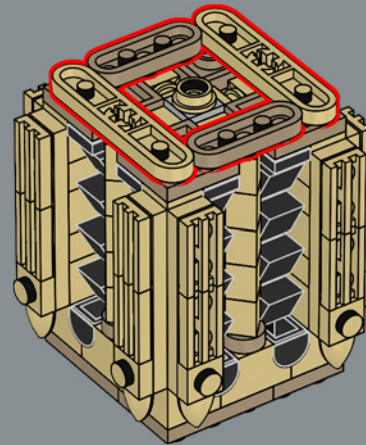

2x

Le torri ospitano le leggendarie campane della cattedrale.  
Furono installate per la prima volta nella torre nord,  
conosciuta anche come Grosse Tour o "Torre Guillaume".

339

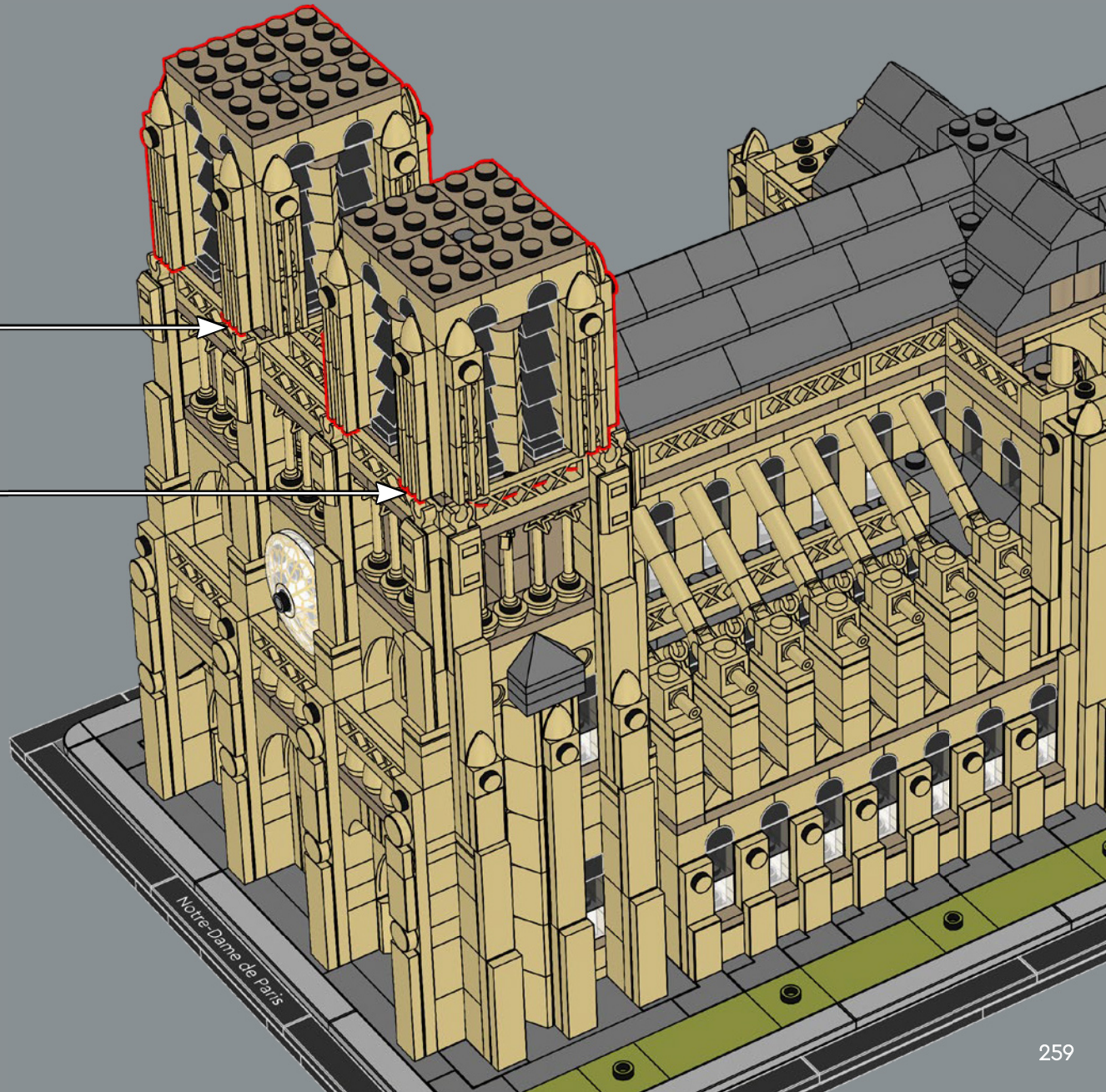



340

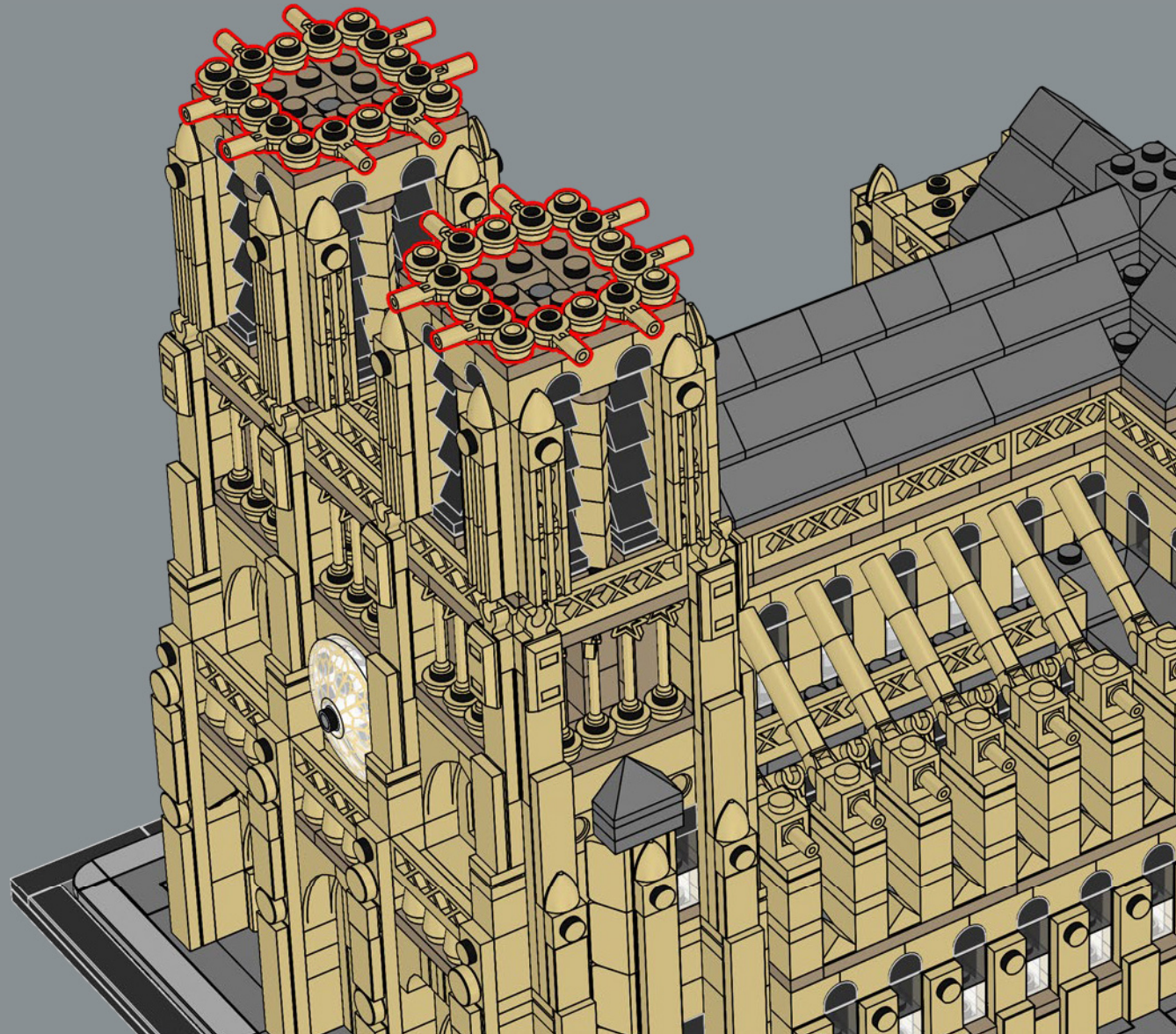



341

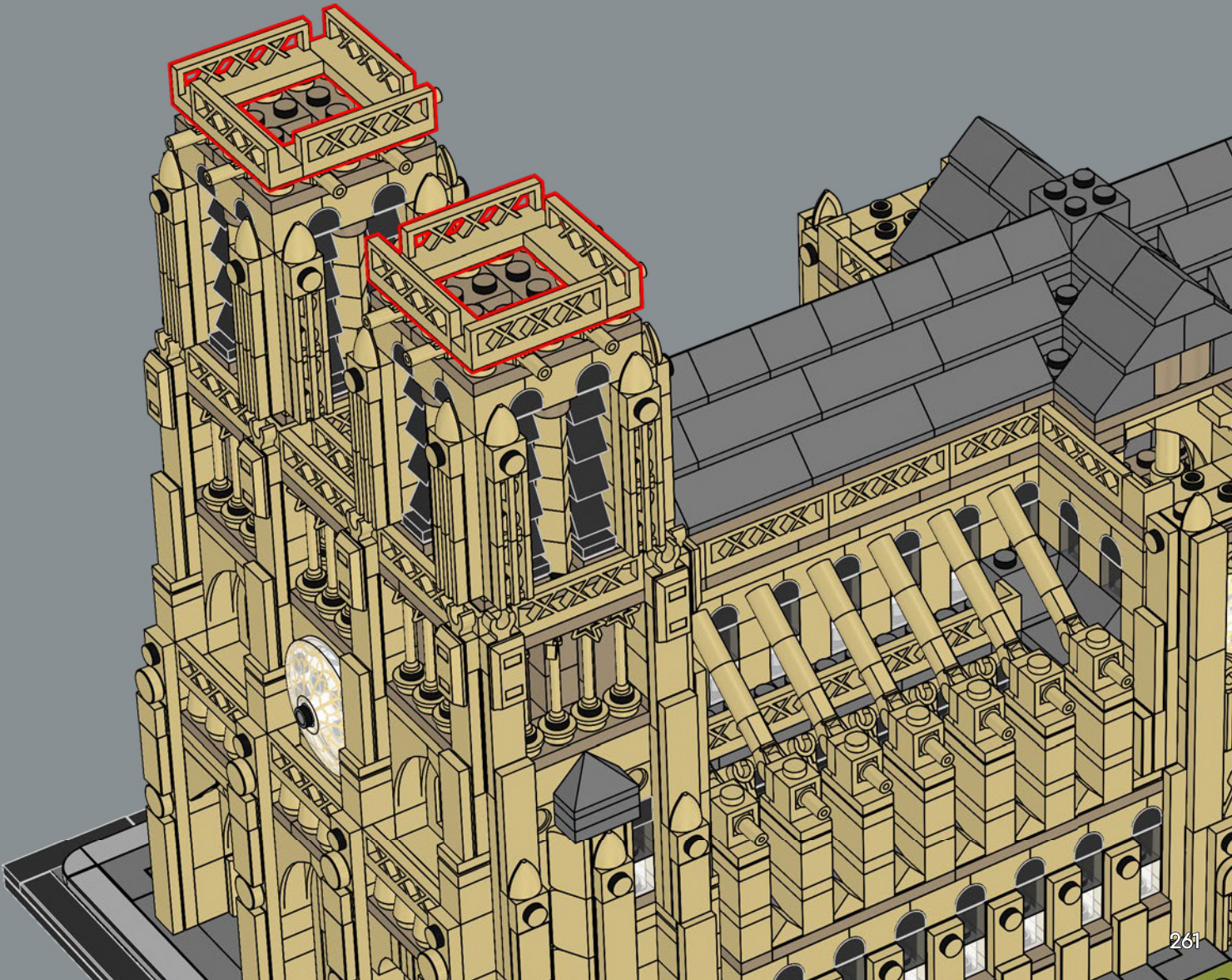

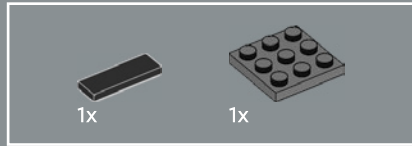

342

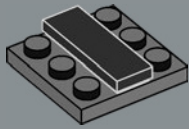

343

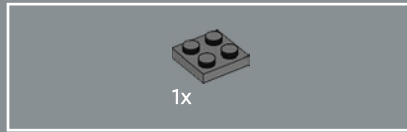
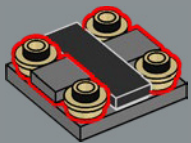

344

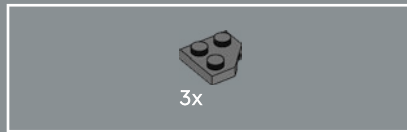
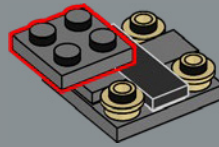

345

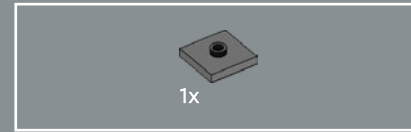
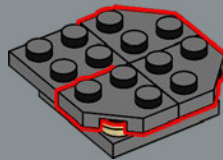

346

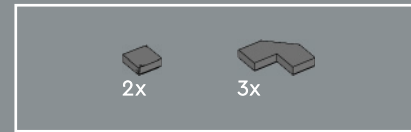
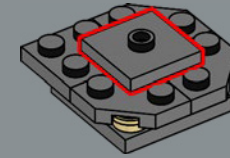

347

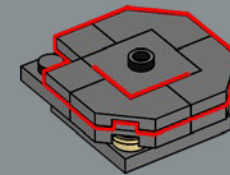



348

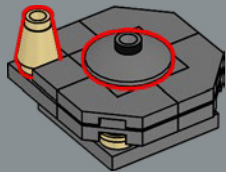

2x

349

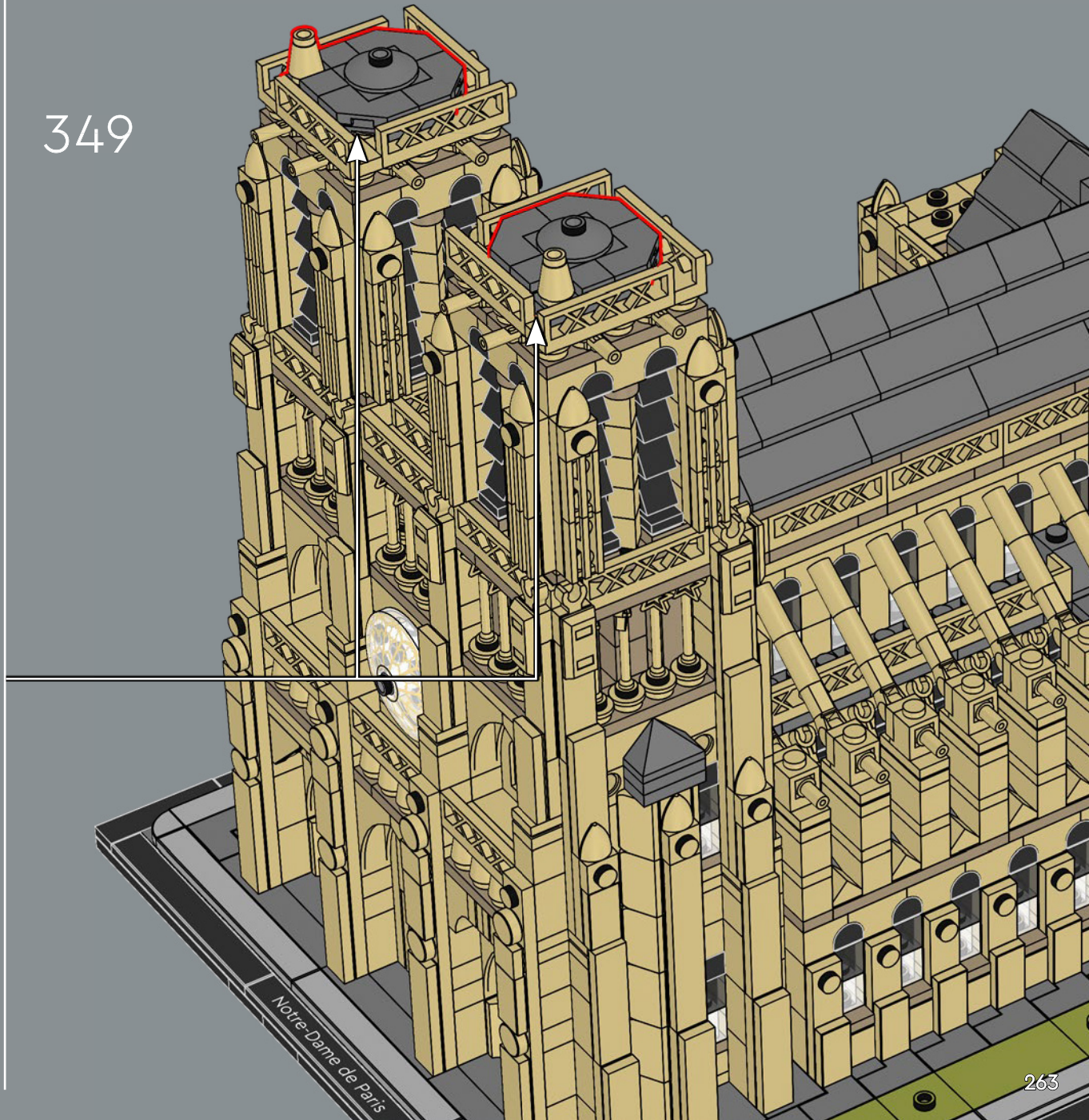

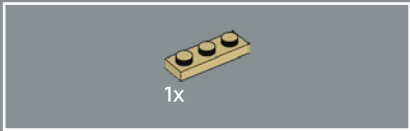
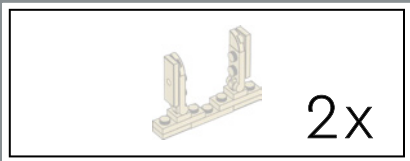

350

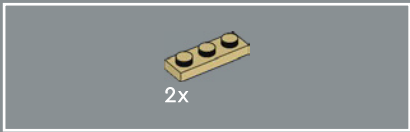
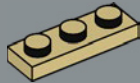

351

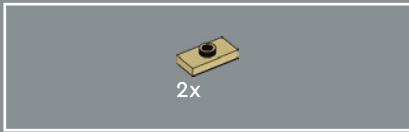
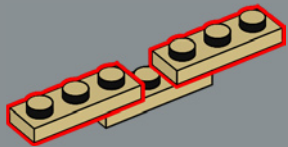

352

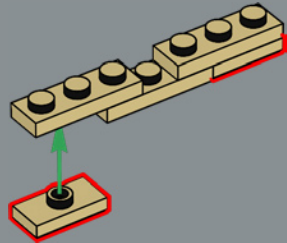

353

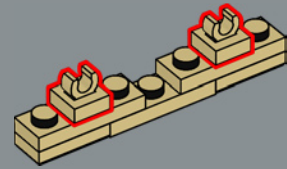

354

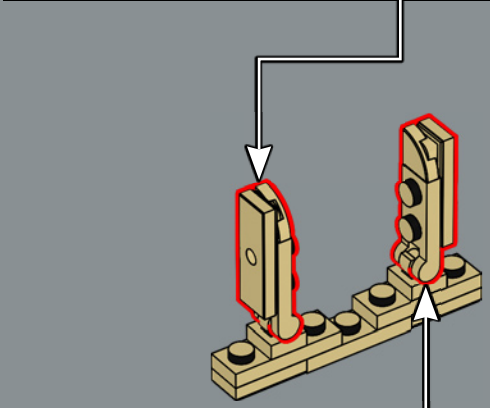
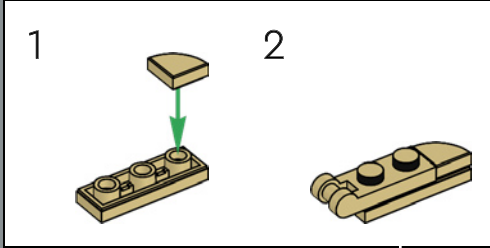

2x

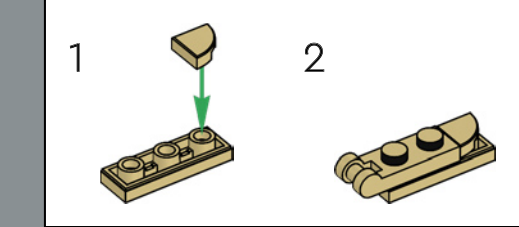



355

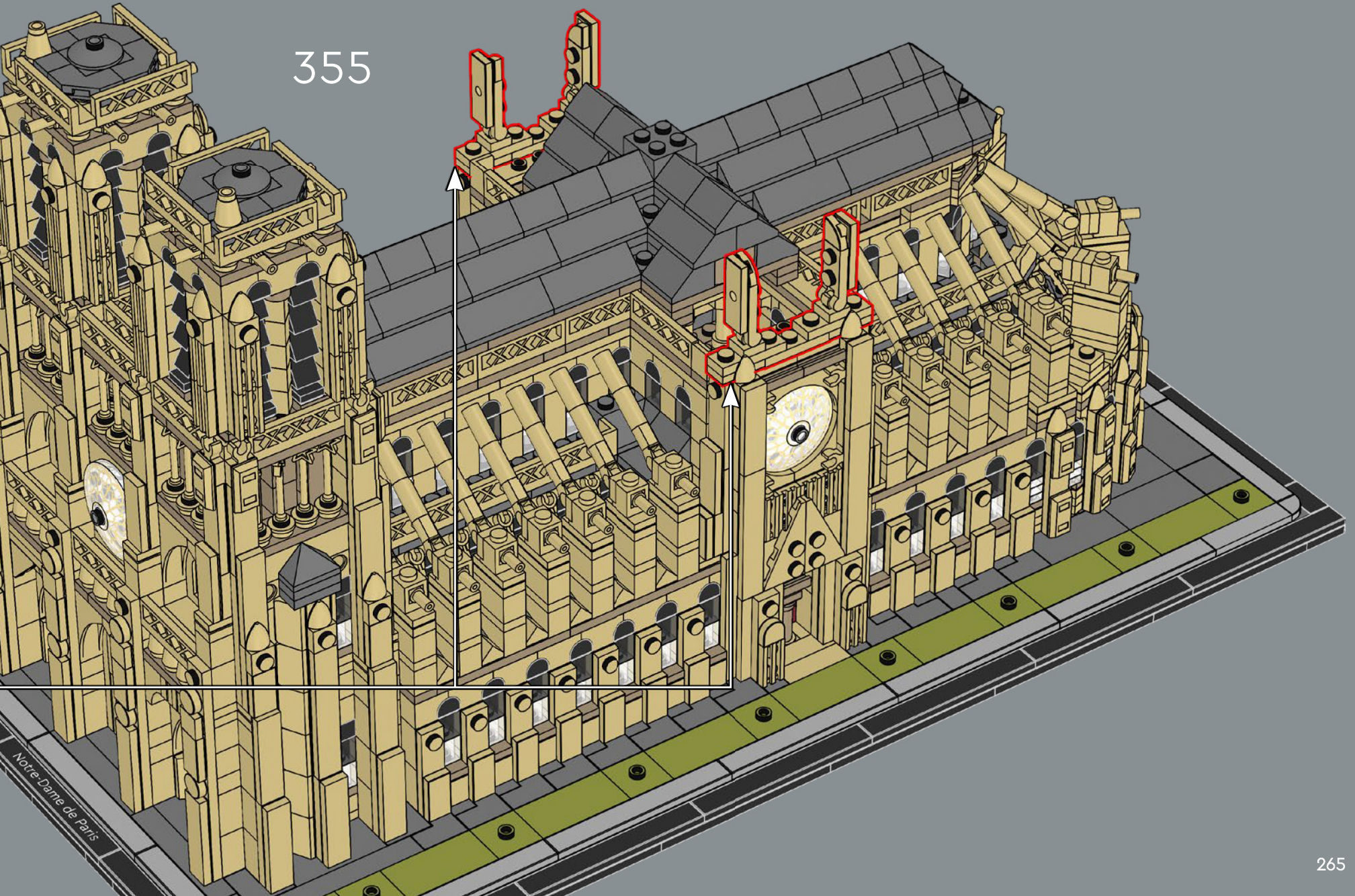

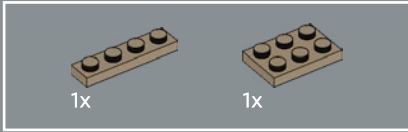

356

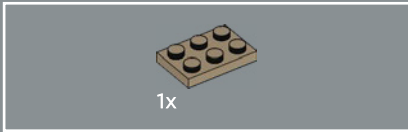
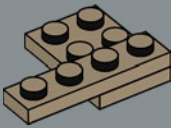

357

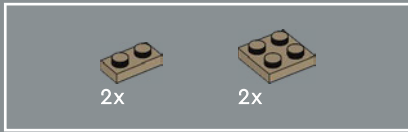
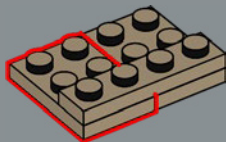

358

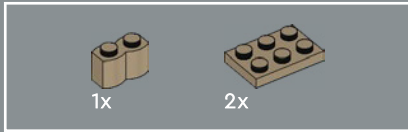
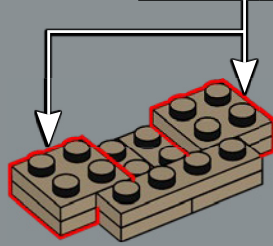
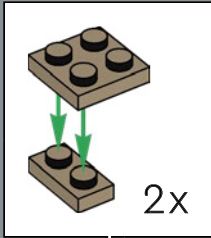

359

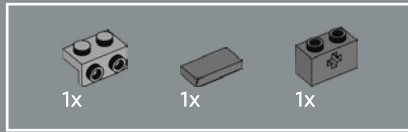
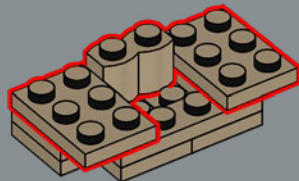

360

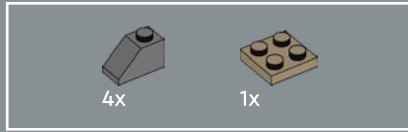
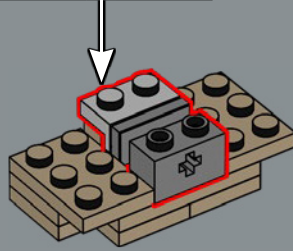
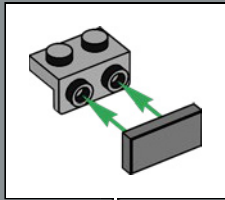

361

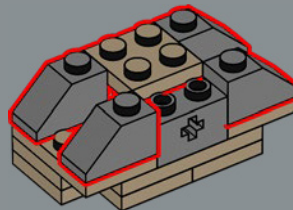

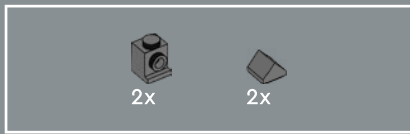

362

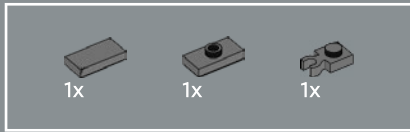
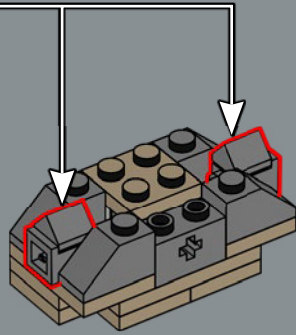
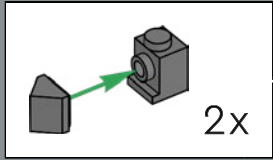

363

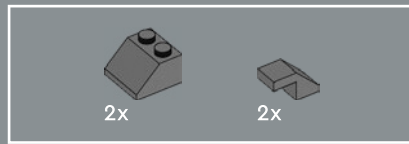
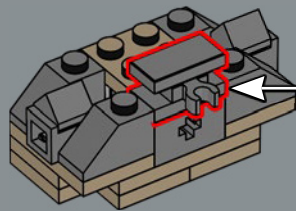
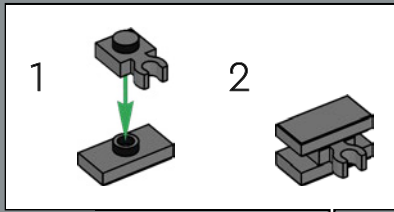

364

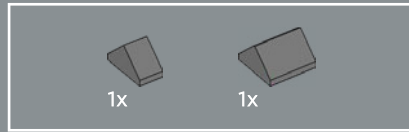
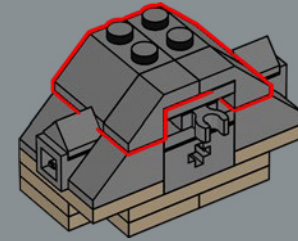

365

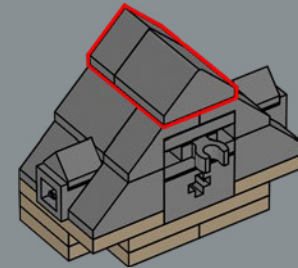



366

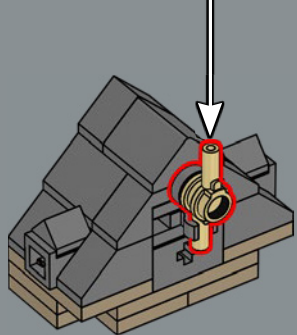
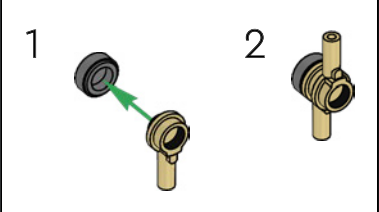

367

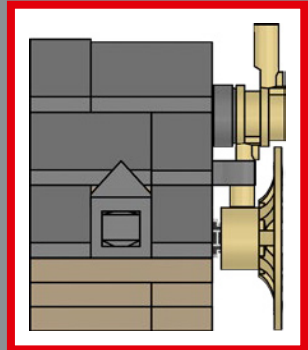
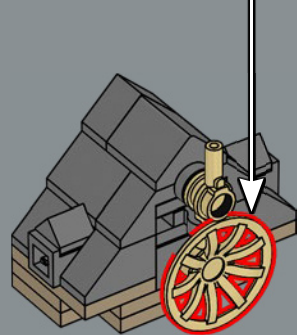
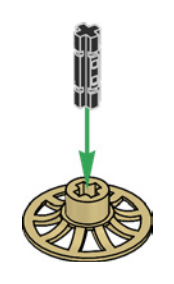

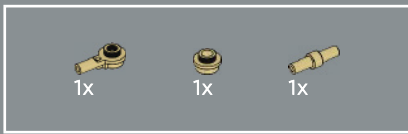

368

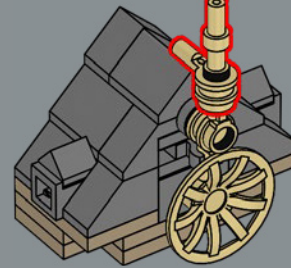
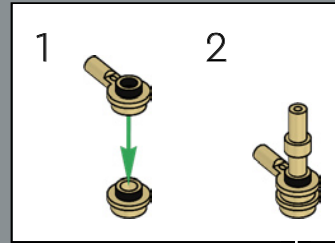

2x

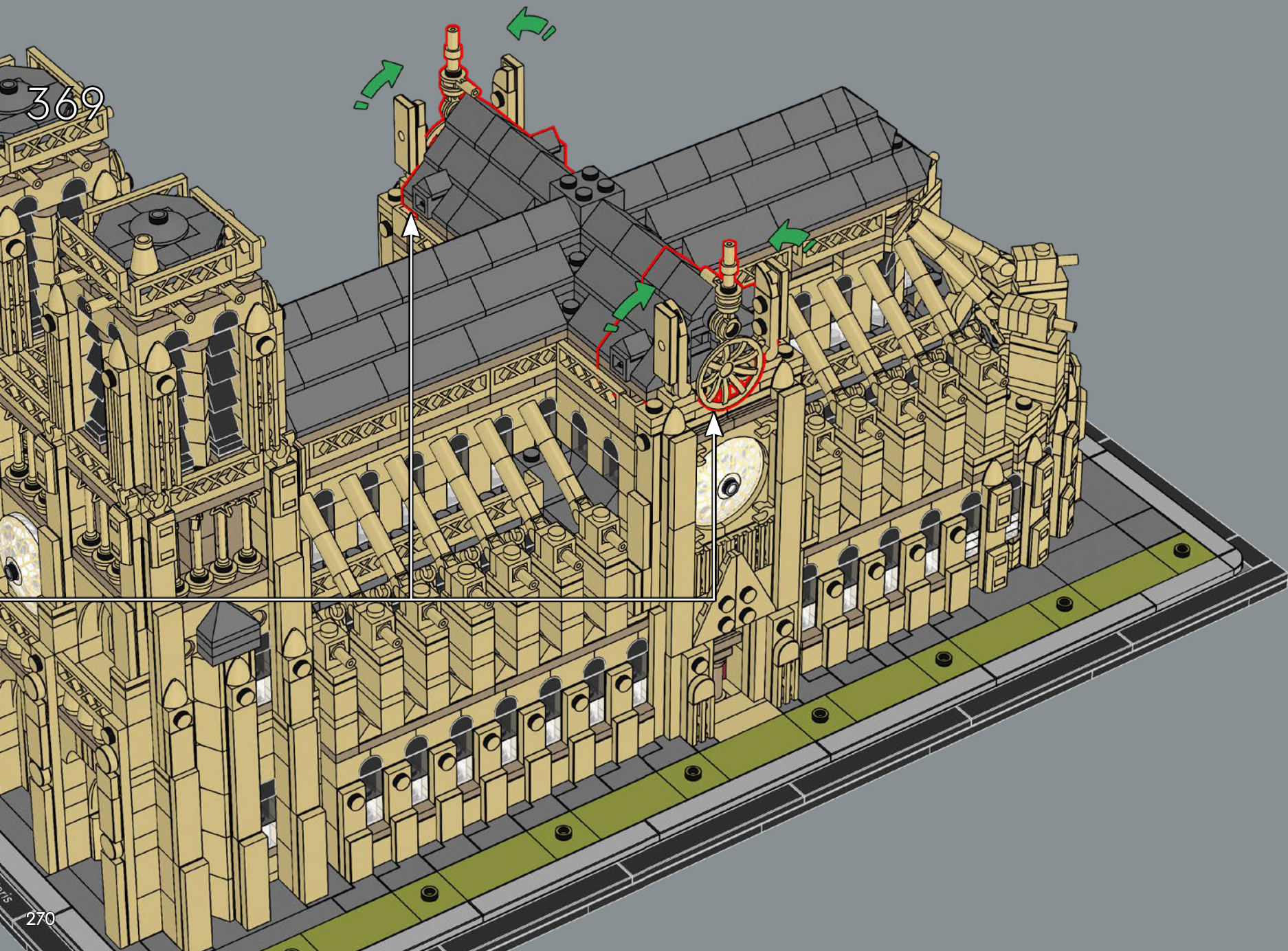

369

270

1245 - Continuano le modifiche e vengono aggiunte cappelle laterali lungo la navata.

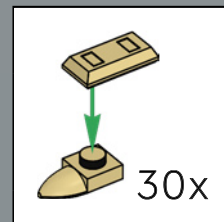
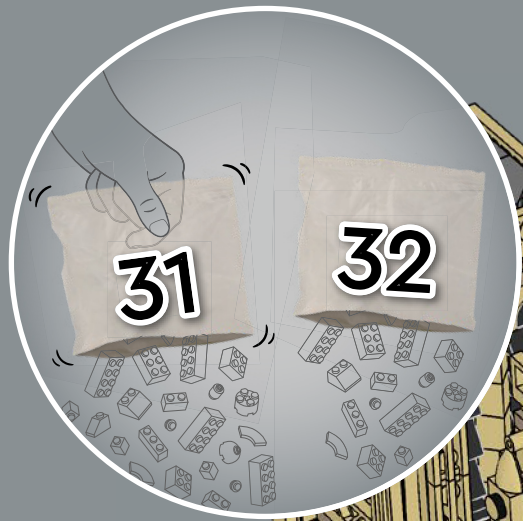

370



1789-1860



## RIVOLUZIONE E LASCITO CULTURALE

✂ Durante gli anni turbolenti della Rivoluzione francese (1789-1799), la nobile cattedrale di Notre-Dame subì diversi danni e un progressivo decadimento. Finestre, altari e tombe furono distrutte e le campane furono rimosse per essere fuse. Nel 1792, i rivoltosi abbattono le statue della Galleria dei Re e smantellarono la guglia. Per un certo periodo, la cattedrale fu utilizzata anche per conservare vino e altri beni. Ma al termine della rivoluzione, l'apprezzamento del patrimonio nazionale francese cominciò a diffondersi in tutta la nazione. La pubblicazione e il grande successo internazionale de *Il gobbo di Notre-Dame* (1831) di Victor Hugo consolidarono lo status della cattedrale come gioiello culturale nella storia del mondo. Dal 1843 al 1860, gli architetti Jean-Baptiste Lassus e Eugène-Emmanuel Viollet-le-Duc furono incaricati di un grande progetto di restauro, fino alla versione dell'edificio che conosciamo oggi.





371

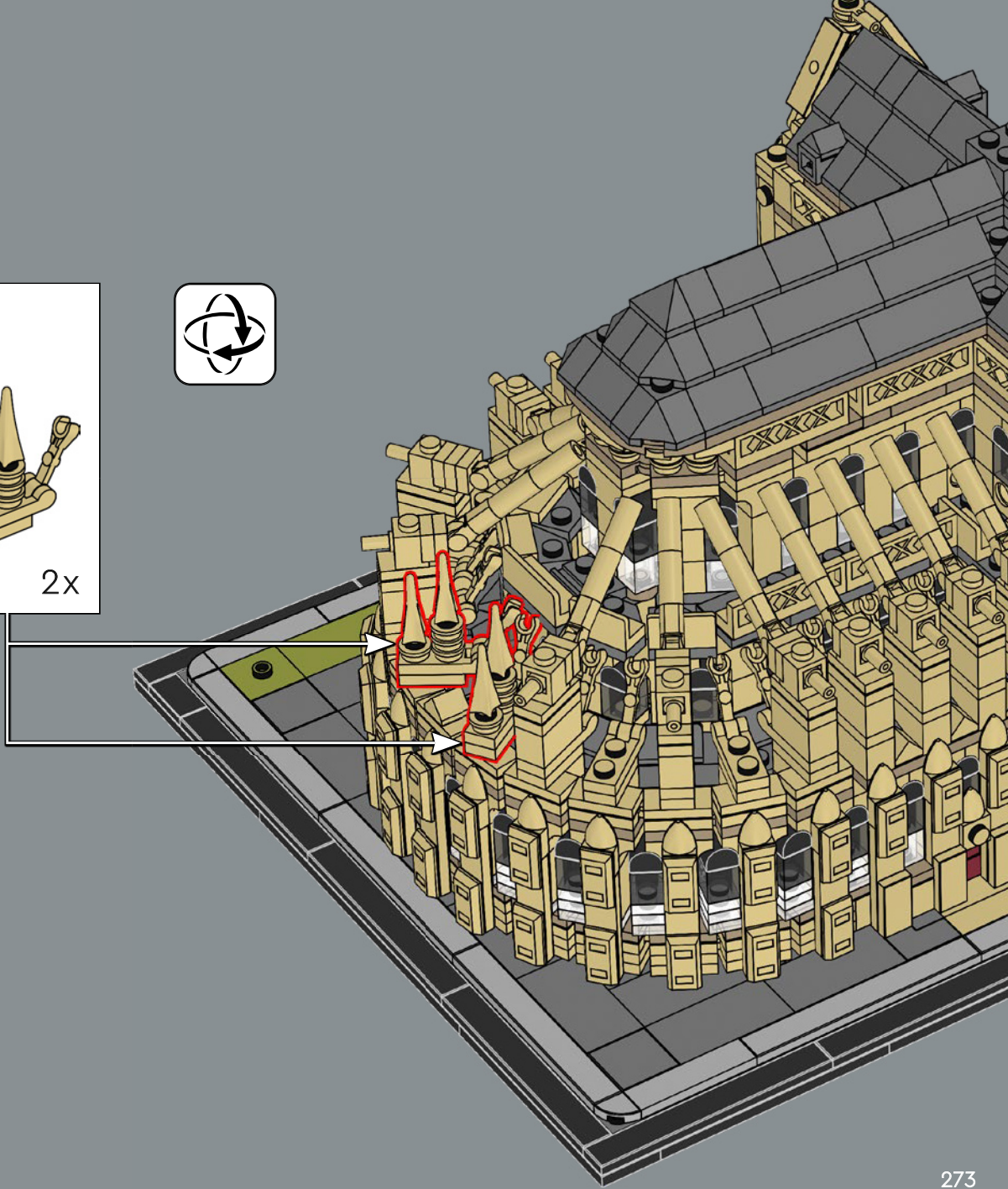
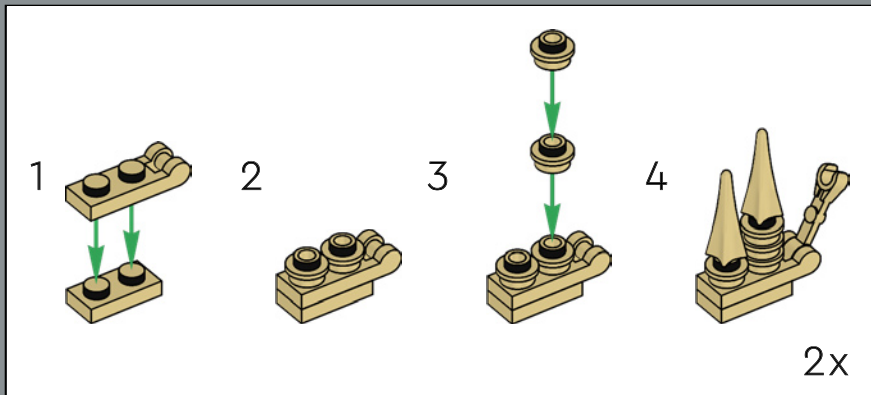



372

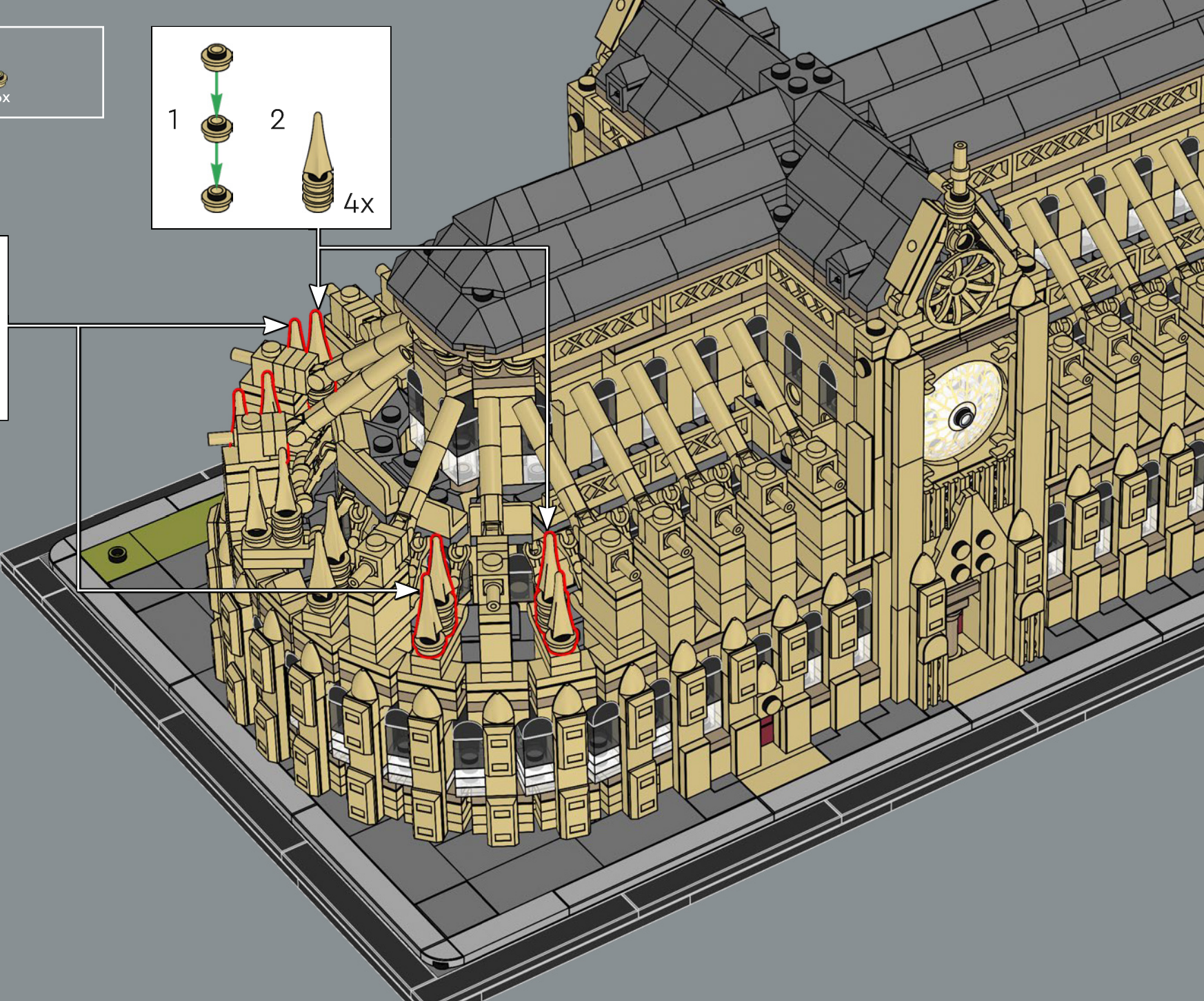
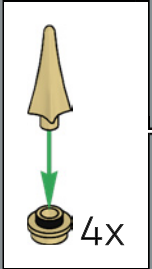
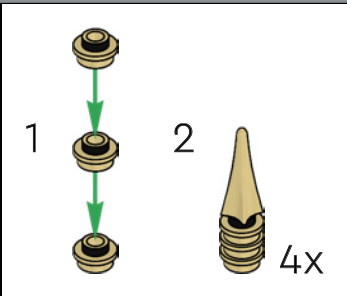



14x



28x

1350 – Gli ultimi ritocchi a Notre-Dame sono completati; furono ritoccati i pinnacoli sui montanti degli archi rampanti prima di essere nuovamente sostituiti nel XIX secolo.

373

1



2



14x

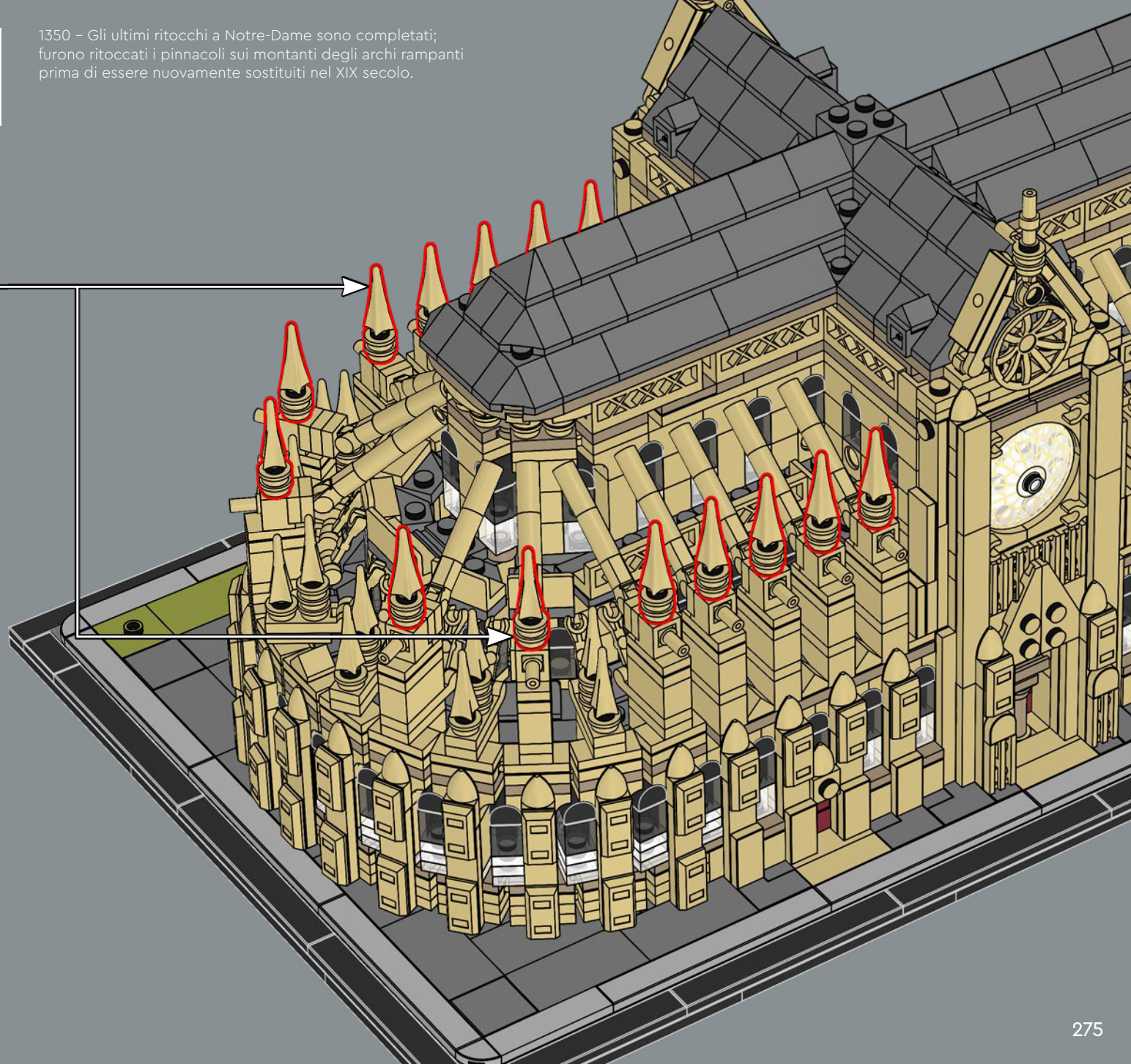



374

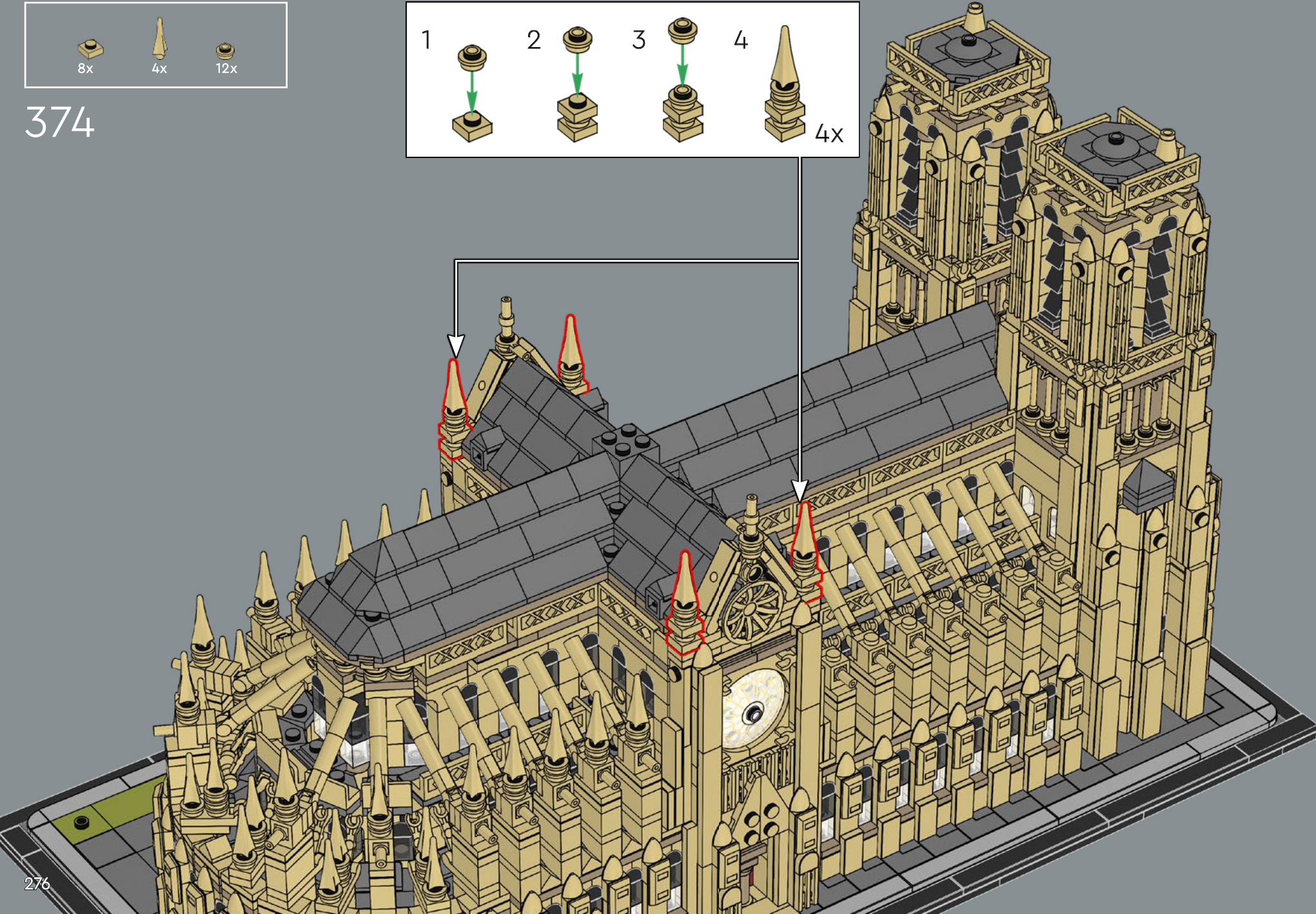
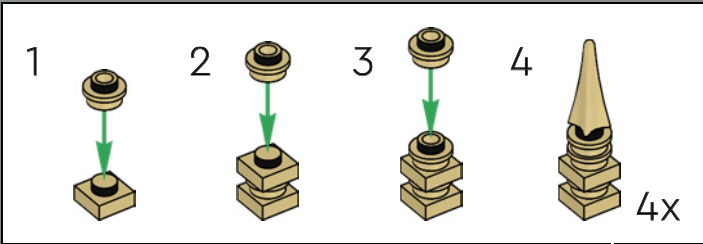



14x



14x

1858 - Jean-Baptiste Lassus e Eugene-Emmanuel Viollet-le-Duc  
aggiungono i tabernacoli sugli archi rampanti.

375



14x

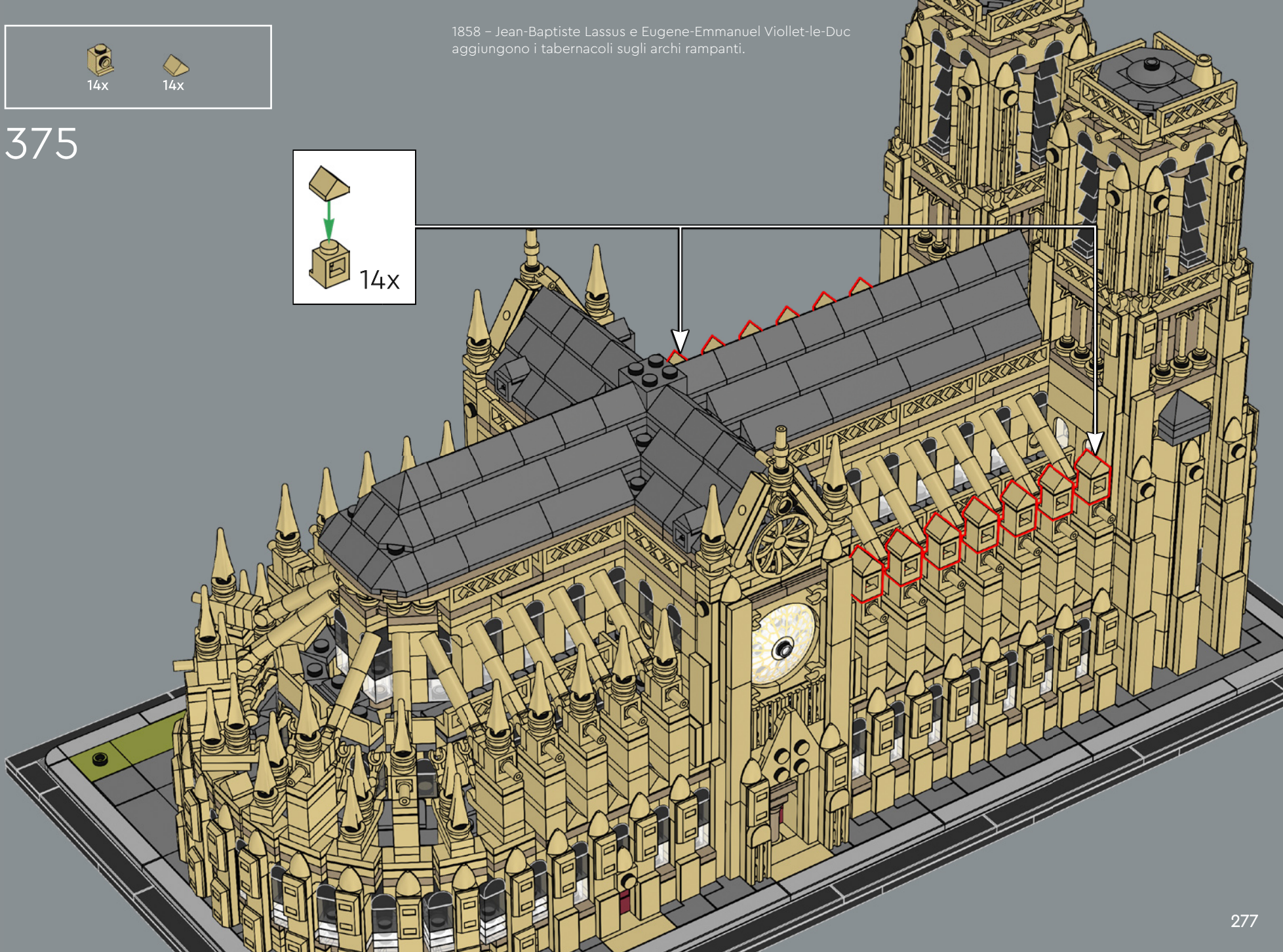

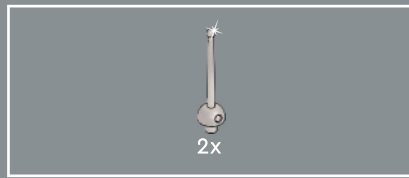

376

Grazie alla due torri della facciata occidentale, alte 69 m, la Cattedrale di Notre-Dame era l'edificio più alto di Parigi, fino alla costruzione della Torre Eiffel (1887-1889).

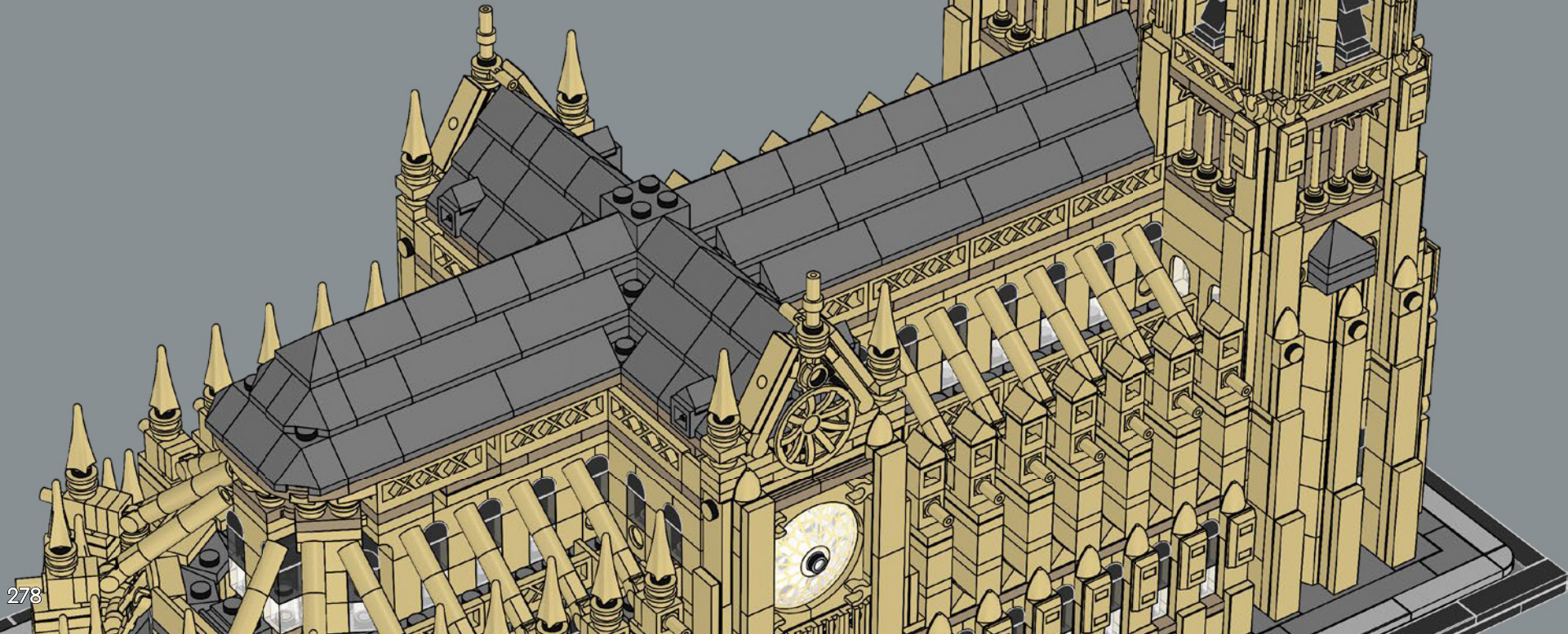



8x

# 377

1843-1860 – Importante restauro di Jean-Baptiste Lassus e Eugene-Emmanuel Viollet-le-Duc.

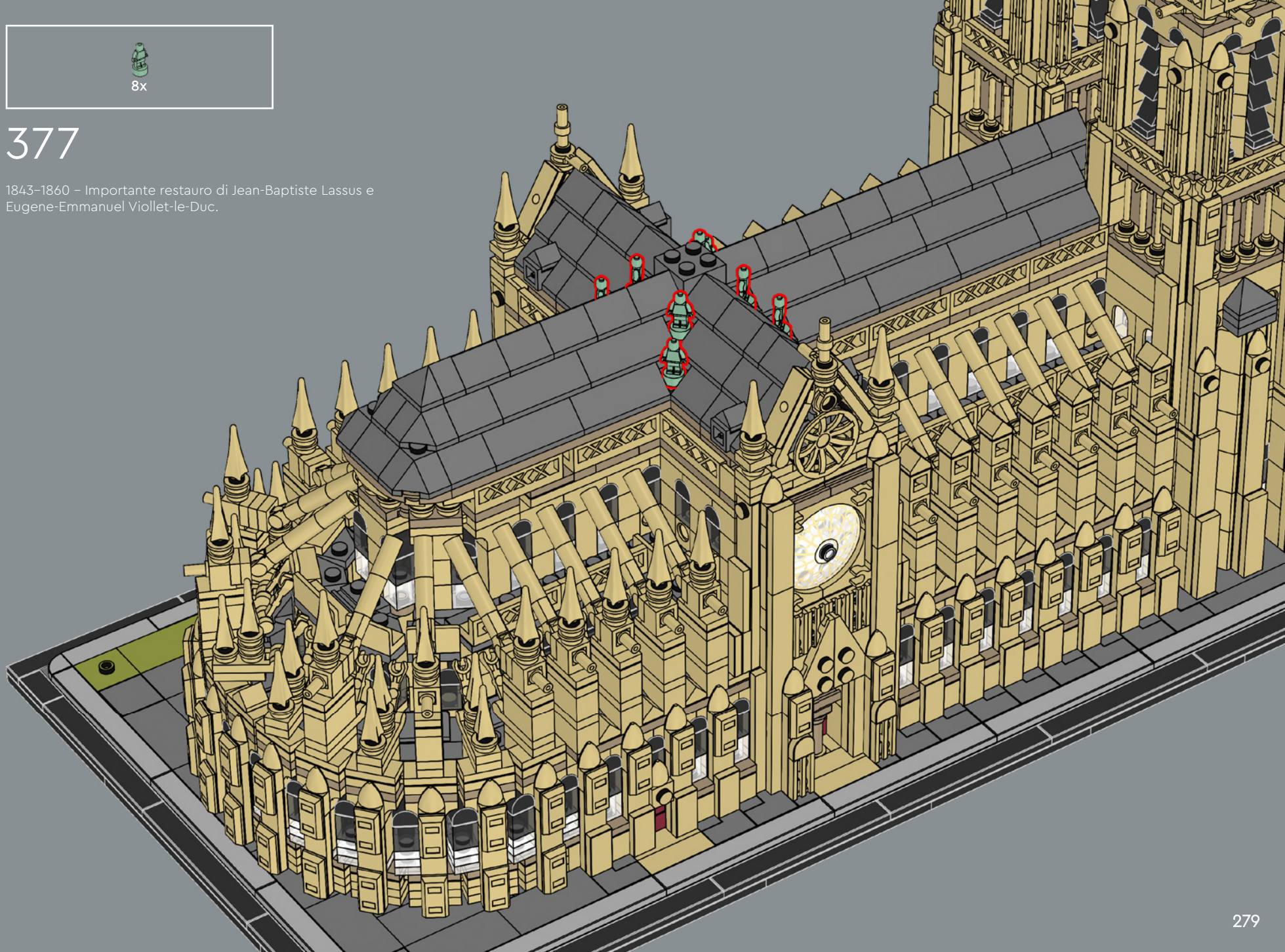

- 2x
- 1x
- 1x
- 8x



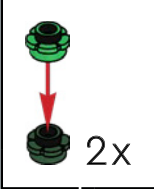

378

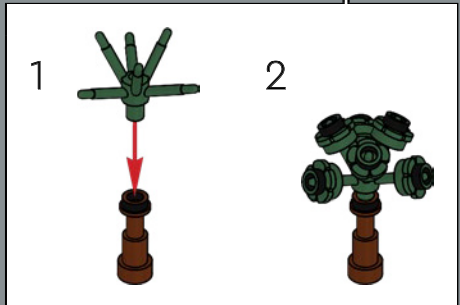

*Notre-Dame de Paris*







 18x  
 3x  
 3x

379



1   
 2  3x

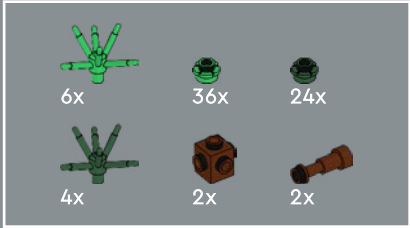
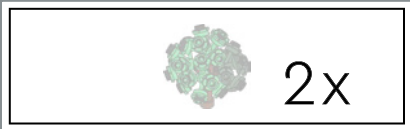

Dimensioni attuali della Cattedrale di Notre-Dame: larghezza della facciata: 43,5 m. Larghezza del transetto: 48 m. Lunghezza totale: 128 m. Altezza della guglia: 96 m. Altezza delle torri: 69 m. Altezza del tetto della navata: 35 m.

380

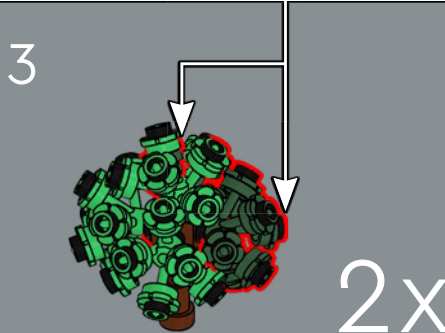
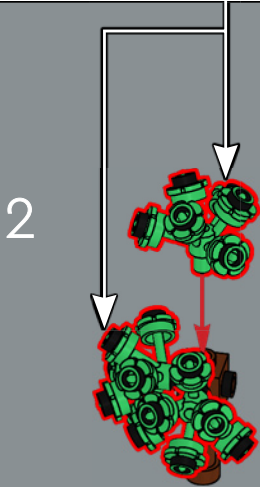
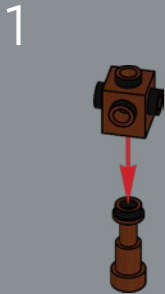
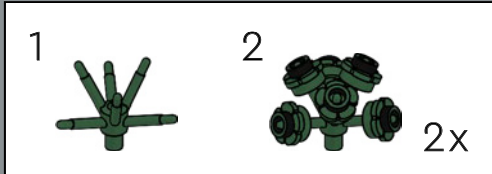
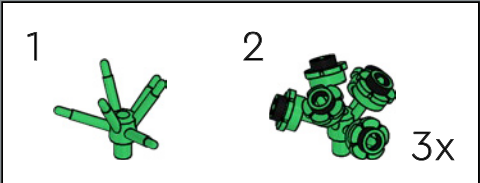



Notre-Dame de Paris

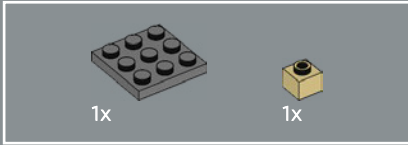
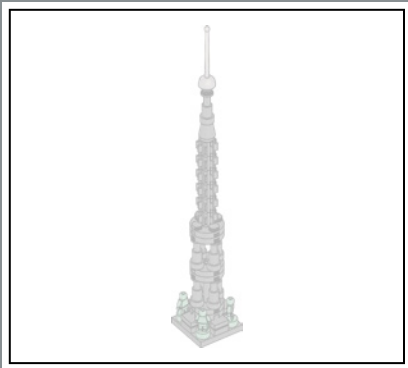

381

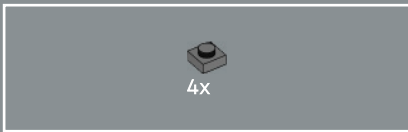
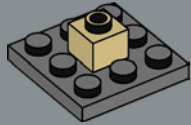

382

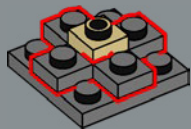

383

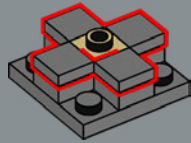

384

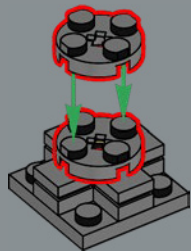

385

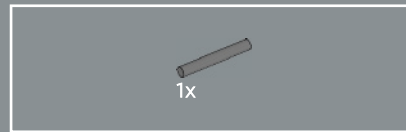
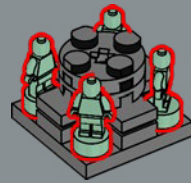

386

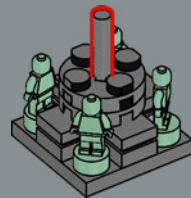



387

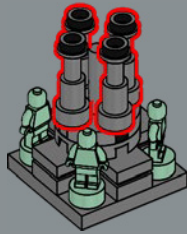

389

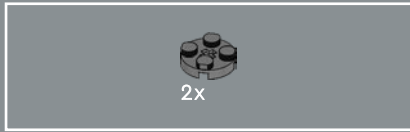
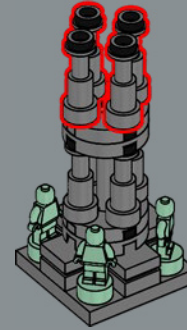

388

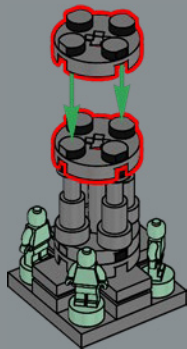

390

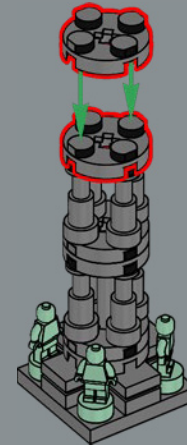

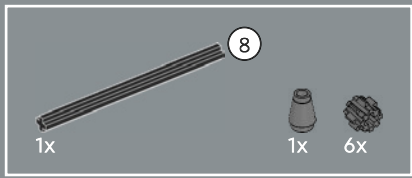

391

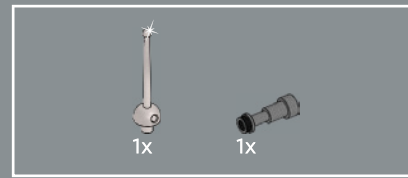
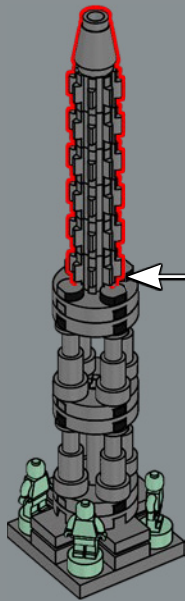
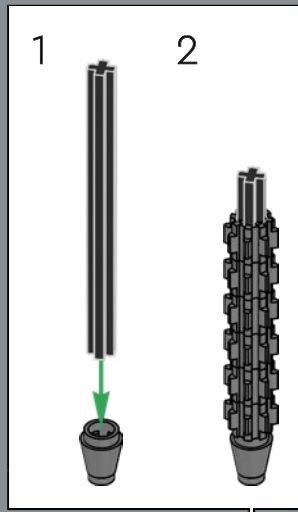

392

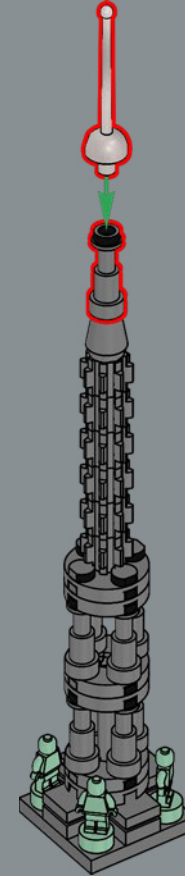

1860 - Viene ricostruita la guglia, ora più snella e più alta dell'originale, con l'aggiunta delle sculture dei 12 apostoli lungo lo spiovente del tetto.

Le porte anteriori della Cattedrale Notre-Dame LEGO® sono aperte per permetterci di sbirciare al suo interno e provare il senso di stupore che tutti sperimentano quando accedono all'intricato e vasto spazio arcuato al suo interno.

393

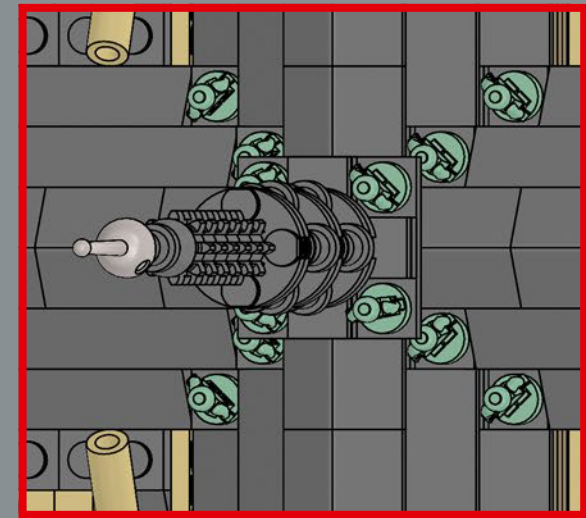

L'unica statua di fronte alla guglia ha il volto di Eugene-Emmanuel Viollet-le-Duc, uno degli architetti della cattedrale. Sembra osservare la guglia, apprezzando sicuramente l'edificio, mentre gli altri vegliano su Parigi.

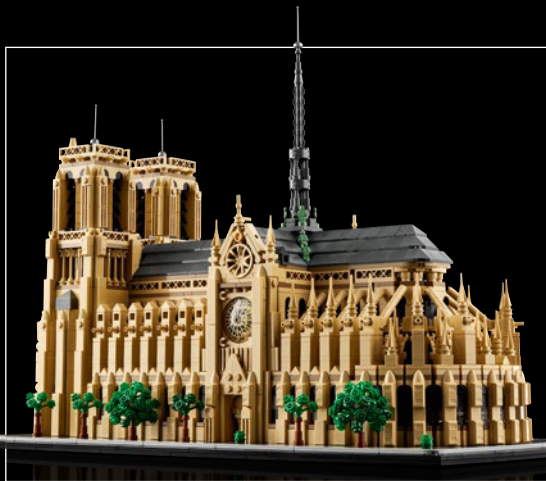

---

## INCENDIO E RICOSTRUZIONE

☞ Dopo il devastante incendio dell'aprile 2019, la cattedrale di Notre-Dame è stata chiusa a tempo indeterminato, in attesa della ricostruzione. Mentre il mondo osservava i soccorritori spegnere l'incendio, numerose campagne globali hanno consentito di raccogliere contributi enormi per finanziare gli sforzi di ricostruzione, in tempi record. Una testimonianza dell'impatto duraturo che la Cattedrale di Notre-Dame ha esercitato sulle persone di ogni cultura nel corso della sua esistenza e dello spirito incomparabile di Parigi. Con quasi 900 anni di storia racchiusi in più di 4.000 elementi LEGO®, siamo entusiasti di includere questo modello nella nostra collezione LEGO Architecture.







6x  
4616711



80x  
6300322



8x  
6231386



12x  
6449564



1x  
6167854



2x  
6300321



8x  
6458397



32x  
6446790



5x  
6398343



5x  
6264025



1x  
6341471



2x  
6133765



7x  
6428178



6x  
6310449



1x  
4211389



2x  
6267495



6x  
4211511



2x  
4213567



6x  
6383177



4x  
6401023



4x  
4211356



6x  
4211445

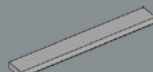

16x  
4211481



2x  
4654582



2x  
6469440



4x  
6176433



12x  
6335936



4x  
4211098



1x  
4211088



3x  
4211060



1x  
4211085



4x  
4211044



4x  
4558955



18x  
4535930



22x  
4211127



12x  
4210848



4x  
4210719



9x  
4211063



14x  
4211052



14x  
6092572



16x  
4210635



2x  
6126083



2x  
6309059



6x  
6177079



10x  
4211094



2x  
4211055



31x  
6247784



31x  
6343852



4x  
4568734



1x  
4211133



12x  
4211043



2x  
4211053



19x  
6039176



4x  
6307616



19x  
4560184



5x  
42110651



1x  
4243831



2x  
4210998



1x  
4211115



1x  
4211134



2x  
6296892



1x  
4543086



9x  
6284596



2x  
4210633



4x  
6221607



3x  
4210872



3x  
4210869



6x  
4211042



2x  
4211010



10x  
6164073



2x  
4527082



1x  
6310596



9x  
6396412



6x  
6012451



20x  
4211045



6x  
4218188



2x  
4210678



20x  
4211114



3x  
6222063



8x  
6212080



8x  
6016488



86x  
6470140



24x  
6446336

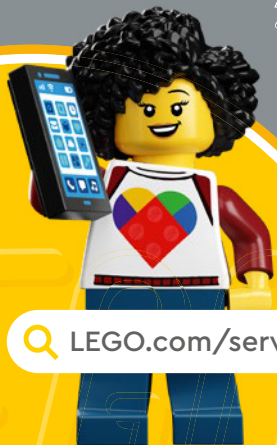

[LEGO.com/service](https://www.LEGO.com/service)



# YOU COULD WIN



## YOU COULD WIN

Your feedback will help shape the future development of this product series.

Visit:

## DU KÖNNTEST GEWINNEN

Dein Feedback trägt zur Weiterentwicklung dieser Produktreihe bei.

Geh auf:

## VOUS POURRIEZ GAGNER

Vos commentaires nous aideront à concevoir les futurs produits de cette gamme.

Visitez :

## POTRESTI VINCERE TU

La tua opinione ci aiuterà a migliorare la creazione futura di questa linea di prodotti.

Visita:

## PUEDES GANAR

Tu opinión contribuirá al futuro de esta serie de productos.

Visita:

## 轻松获奖

您的反馈将有助于我们在今后改进本产品系列。

请访问:

---

[LEGO.com/productfeedback](https://www.lego.com/productfeedback)

---

You also have the chance to win a LEGO® set.

Terms and conditions apply.\*

Außerdem hast du die Chance, ein LEGO® Set zu gewinnen.

Es gelten die Teilnahmebedingungen.\*

Vous pourriez également gagner un ensemble LEGO®.

Des conditions s'appliquent.\*

Hai anche la possibilità di vincere un set LEGO®.

Termini e condizioni sono applicabili.\*

También tienes la oportunidad de ganar un set LEGO®.

Aplican términos y condiciones.\*

您还有机会赢取乐高®套装。

条款和条件适用。\*

\*[LEGO.com/productfeedback-terms](https://www.lego.com/productfeedback-terms)

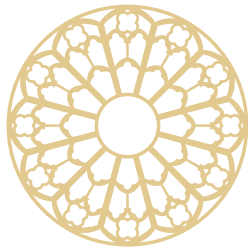

LEGO and the LEGO logo are trademarks of the LEGO Group. ©2024 The LEGO Group.  
Adam Reed Tucker is the co-developer of the LEGO® Architecture product line.