

VIDEO COMPUTER SYSTEM

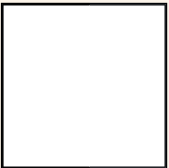

Booklet available in English on
Livret disponible en français sur
Folleto disponible en español en



HAVE YOU BUILT ATARI® TODAY?

Unveiled in 1977, the ATARI® Video Computer System brought the realistic thrills of the arcade into the home and would go on to become one of the most popular gaming systems in history with 30 million units sold. This LEGO® version of the ATARI® Video Computer System is the iconic four-switch CX-2600A from 1980. It's full of authentic details and hidden gems that will take you back in time to the halcyon days of classic gaming. Enjoy.

AVEZ-VOUS CONSTRUIT UN ATARI® AUJOURD'HUI?

Dévoilée en 1977, la console de jeu vidéo ATARI® fait entrer les joies des salles d'arcade dans les foyers et devient l'une des consoles de jeu les plus populaires de l'histoire avec 30 millions d'unités vendues. Cette version LEGO® de la console de jeu vidéo ATARI® représente l'emblématique CX-2600A à quatre commutateurs de 1980. Elle regorge de détails authentiques et de bijoux cachés qui vous feront remonter le temps jusqu'à l'époque glorieuse des jeux classiques. Amusez-vous !

¿YA CONSTRUISTE HOY TU ATARI®?

Presentado en 1977, el ATARI® Video Computer System (VCS) trasladó el realismo y las emociones de las salas de maquinitas a los hogares, llegando a convertirse en uno de los sistemas de videojuegos más populares de la historia, con 30 millones de unidades vendidas. Esta versión LEGO® del ATARI® Video Computer System corresponde al inconfundible CX-2600A de cuatro interruptores de 1980. El modelo está repleto de detalles de gran realismo y joyas ocultas que te permitirán regresar en el tiempo a los felices días de los videojuegos clásicos. Esperamos que lo disfrutes.

THE GAMING ICON

As incredible as it sounds, the four-switch CX-2600A – the most popular version of the ATARI® Video Computer System – celebrates its 42nd anniversary in 2022. It set the standard for console gaming in its day and remains the starting point for all retro console design from ATARI® today.

L'ICÔNE DU JEU

Aussi incroyable que cela puisse paraître, le modèle CX-2600A à quatre commutateurs (la version la plus populaire de la console de jeu vidéo ATARI®) fête son 42^e anniversaire en 2022. Elle a posé les bases du jeu sur console à son époque et demeure le point de départ de toutes les formes de consoles rétro d'ATARI®.

UN ÍCONO DE LOS VIDEOJUEGOS

Por increíble que parezca, el CX-2600A de cuatro interruptores, la versión más popular del ATARI® Video Computer System, celebra su 42 aniversario en 2022. Sentó las bases de los juegos de consola en su día y ATARI® sigue considerándolo el punto de partida a la hora de diseñar una consola retro.





HAVE YOU PLAYED ATARI TODAY ?

ATARI 50

50 YEARS OF FUN

Founded in 1972 ATARI® remains one of the most iconic names in the gaming world, and more than half a century later the brand continues to resonate with fans and those looking for the thrill of vintage gaming. Namechecked widely in countless TV shows, movies and in pop culture, ATARI® has also become an authentic cultural reference point reaching far beyond its computer gaming origins.

50 ANS D'AMUSEMENT

Fondée en 1972, ATARI® est toujours l'un des noms les plus emblématiques du monde du jeu, et plus d'un demi-siècle plus tard, la marque continue de susciter l'intérêt des amateurs et de tous les joueurs qui désirent goûter aux joies du jeu rétro. Citée dans d'innombrables émissions de télévision, films et autres éléments de la culture populaire, ATARI® est également devenue une référence culturelle authentique qui va bien au-delà de ses origines de jeu sur ordinateur.

50 AÑOS DE DIVERSIÓN

Fundada en 1972, ATARI® sobrevive como uno de los nombres más representativos del mundo de los videojuegos; más de medio siglo después, la marca sigue resonando entre los aficionados y quienes buscan la emoción de los antiguos juegos. Con una amplia presencia en incontables programas de televisión, películas y la cultura pop en general, ATARI® también se ha convertido en un verdadero referente que va mucho más allá de sus orígenes en el ámbito de los juegos informáticos.



← The cartridge system allowed players to immerse themselves in many different games

← Le système de cartouches permettait aux joueurs de plonger dans une multitude de jeux différents.

← El sistema de cartuchos permitía a los jugadores sumergirse en numerosos juegos diferentes

↓ Advertisement for the ATARI® Video Computer System

↓ Publicité pour la console de jeux vidéo ATARI®

↓ Anuncio del ATARI® Video Computer System

ATARI®

THERE'S NO COMPARING IT WITH ANY OTHER VIDEO GAME.

Only ATARI makes the games the world wants most. Games that are innovative. Intense. Incredibly involving. And totally original.

The most games, the best games, are only from ATARI. Atari makes more video game cartridges than anyone else. Today ATARI Missile Command and Asteroids are the fastest selling home video games in the country.



NIGHT DRIVER	▲
SCOTTRACKERS	▲
ASTEROIDS	▲
BACKLASH	▲
KRAMI CONQUEST	▲
LURIELORDS	▲
CHESS	▲
BASKETBALL	▲
RACE	▲
HOME RUN	▲
STREET RACER	▲
ADVENTURE	▲
MISSILE COMMAND	▲
BIRLACROT	▲
VIDEO CHESS	▲
CONCENTRATION	▲
CODEBREAKER	▲
GOLE	▲
CASINO	▲
BLACKJACK	▲
FOOTBALL	▲
SOFTDIVER	▲
SOFTDIVER 2	▲
HAWKMAN	▲
BRUN JAMES	▲
VIDEO PINBALL	▲
BOWLING	▲
AGENT X	▲
VIDEO CHESS	▲
CORNER KICK	▲
DODGE 'EM	▲
WHEEL ORICE	▲
VIDEO CHECKERS	▲
ARCADE BATTLE	▲
COMBAT	▲
STAR WARRIORS	▲

MORE GAMES. MORE FUN.

Unlike many earlier gaming systems that only offered a single integrated game, ATARI® used a cartridge system that allowed a virtually limitless selection of games. A total of 527 games would be published for the ATARI® Video Computer System and hits such as *Asteroids*, *Ms. Pac-Man*, and *Pitfall* established it as the must-have gaming system in the late '70s and early '80s.

PLUS DE JEUX. PLUS D'AMUSEMENT.

Contrairement à d'autres anciens systèmes de jeu qui ne proposaient qu'un seul jeu intégré, ATARI® utilisait un système de cartouches qui offrait une sélection pratiquement illimitée de jeux. Au total, 527 jeux ont été lancés sur la console de jeux vidéo ATARI®, et des classiques comme *Asteroids*, *Ms. Pac-Man* et *Pitfall* en ont fait la console de jeu incontournable de la fin des années 70 et du début des années 80.

MÁS JUEGOS. MÁS DIVERSIÓN.

A diferencia de otros muchos sistemas de juego anteriores que solo ofrecían un único juego integrado, ATARI® optó por un sistema de cartuchos que abría las puertas a una gama de juegos virtualmente ilimitada. Se publicaron 527 juegos en total para el ATARI® Video Computer System, y éxitos como *Asteroids*, *Ms. Pac-Man* y *Pitfall* lo convirtieron en un sistema de juego infaltable a finales de los 70 y principios de los 80.



1980
ADVENTURE

In a game that would inspire a whole generation of quest adventures, the wicked wizard has stolen your castle's magical chalice and you must lead your brave knight through terrible dangers to ensure its safe return!

1980
ADVENTURE

Dans ce jeu qui inspirera toute une génération d'aventures de quête, vous devez mener un courageux chevalier à travers de graves dangers pour récupérer le calice magique volé par un méchant sorcier et le rapporter au château !

1980
ADVENTURE

En este juego, que daría lugar a toda una generación de títulos de aventuras, un malvado mago roba el cáliz mágico de tu castillo y tienes que guiar a tu valiente caballero a través de terribles peligros para recuperarlo.



1981
ASTEROIDS

The highly addictive object of this game is to gain the highest score by shooting down waves of asteroids, satellites and UFOs. Once shot, the asteroids break into smaller, faster pieces that fly off in unpredictable directions!

1981
ASTEROIDS

Le but de ce jeu très prenant est de réaliser le meilleur score en tirant sur des vagues d'astéroïdes, de satellites et d'ovnis. Une fois touchés, les astéroïdes se divisent en morceaux plus petits et plus rapides qui se dispersent dans des directions imprévisibles !

1981
ASTEROIDS

El objetivo de este juego, altamente adictivo, es alcanzar la máxima puntuación acabando con oleadas de asteroides, satélites y ovnis. ¡Al alcanzarlos, los asteroides se rompen en trozos más pequeños y rápidos que salen volando en direcciones imprevisibles!



1982
CENTIPEDE

Use the wand at the bottom of the screen to destroy as many bugs as you can. Your nemesis is a long and winding centipede that invades each level. To proceed in the game, you must exterminate each segment of the centipede in every level!

1982
CENTIPEDE

Utilisez la baguette au bas de l'écran pour détruire autant d'insectes que possible. Votre ennemi est un long et sinueux mille-pattes qui envahit chaque niveau. Pour avancer dans le jeu, vous devez éliminer chaque segment du mille-pattes dans chaque niveau !

1982
CENTIPEDE

Usa la varita de la parte inferior de la pantalla para destruir tantos bichos como puedas. Tu némesis es un largo y sinuoso ciempiés que invade la pantalla. ¡Para avanzar en el juego y superar cada nivel, debes exterminar todos los segmentos que lo componen!

BUILDING AN ICON

This 2,532-piece LEGO® model is a close 1:1 representation of the iconic four-switch ATARI® Video Computer System (Model CX-2600A). As well as a replica joystick that plugs into the back of the console, it also has four functioning switches on the front. Three cartridges of famous VCS games are included, and each game is represented by a buildable LEGO vignette visualizing the gaming experience offered. All the games can be stored in a cool '80s-style cartridge holder when not in use!

LA CRÉATION D'UNE ICÔNE

Ce modèle LEGO® de 2 532 pièces est une représentation fidèle à l'échelle 1:1 de l'emblématique console de jeux vidéo ATARI® à quatre commutateurs (modèle CX-2600A). En plus d'une réplique de manette qui se branche à l'arrière de la console, la console comporte également quatre commutateurs fonctionnels à l'avant. Trois cartouches de jeux VCS célèbres sont incluses, et chaque jeu est accompagné d'une vignette LEGO à construire pour illustrer l'expérience de jeu offerte. Tous les jeux peuvent être rangés dans un support de cartouches de style années 80 lorsqu'ils ne sont pas utilisés !

LA CONSTRUCCIÓN DE UN ÍCONO

Este modelo LEGO® de 2532 piezas es una representación 1:1 del emblemático ATARI® Video Computer System de cuatro interruptores (modelo CX-2600A). Además de una réplica del control que se conectaba a la parte trasera de la consola, cuenta también con cuatro interruptores delanteros que se pueden accionar. Incluye tres cartuchos de juegos famosos del VCS, cada uno de ellos representado en una viñeta LEGO construible que ilustra la experiencia de juego que ofrecía. ¡Los juegos se pueden guardar en un genial portacartuchos de los 80 cuando no se están usando!



INCLUDES
**ADVENTURE,
ASTEROIDS™
AND CENTIPEDE™**
CARTRIDGES, PLUS
BUILDABLE VIGNETTES

COMPREND LES CARTOUCHES
**D'ADVENTURE,
D'ASTEROIDS™
CENTIPEDE™**,
ET DE
AINSI QUE DES VIGNETTES
À CONSTRUIRE.

INCLUDE CARTUCHOS
DE LOS JUEGOS
**ADVENTURE,
ASTEROIDS™
Y CENTIPEDE™**,
ASÍ COMO VIÑETAS
CONSTRUIBLES

FRONT PANEL/PANNEAU AVANT/PANEL FRONTAL



BACK PANEL/PANNEAU ARRIÈRE/PANEL POSTERIOR

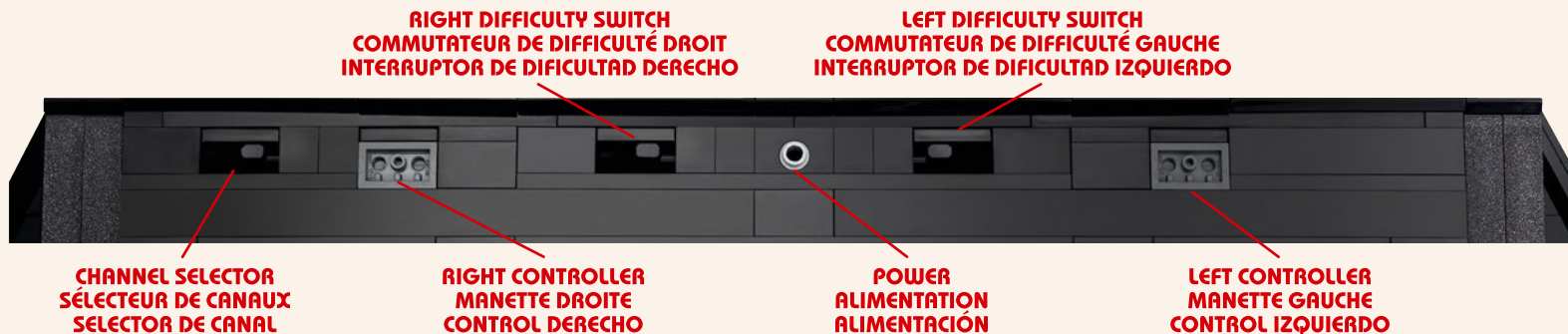

THE ATARI® VIDEO COMPUTER SYSTEM

There were various versions of the ATARI® Video Computer System launched between 1977 and 1992, mostly differentiated by weight, number of switches or the finish of the console itself. The technology, while impressive in its day seems inconceivable today, with a limited processor speed of 1.19 MHz, a total capacity of 128 bytes of onboard RAM and a game cartridge capacity of only 4 kilobytes!

CONSOLE DE JEUX VIDÉO ATARI®

Plusieurs versions de la console de jeux vidéo ATARI® ont été lancées entre 1977 et 1992. Elles se distinguaient principalement par leur poids, leur nombre de commutateurs et leur finition. La technologie, bien qu'impressionnante à l'époque, semble inconcevable aujourd'hui, avec une vitesse de processeur limitée à 1,19 MHz, une capacité totale de 128 octets de RAM, ainsi que des cartouches de jeu d'une capacité de seulement 4 kilo-octets !

EL ATARI® VIDEO COMPUTER SYSTEM

Entre 1977 y 1992 se lanzaron al mercado varias versiones del ATARI® Video Computer System que se diferenciaban principalmente en el peso, el número de interruptores o el acabado de la consola. La tecnología, impresionante en su día, parece inconcebible en la actualidad: ¡una velocidad de procesamiento limitada a 1,19 MHz, una capacidad total de 128 B de memoria RAM soldada en la placa y compatibilidad con cartuchos de juego de solo 4 kB!



ATARI

ENTERTAINMENT
INDUSTRIES
BERKELEY, CA

CENTIPEDE

ADVENTURE

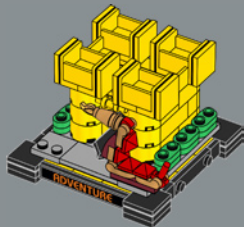
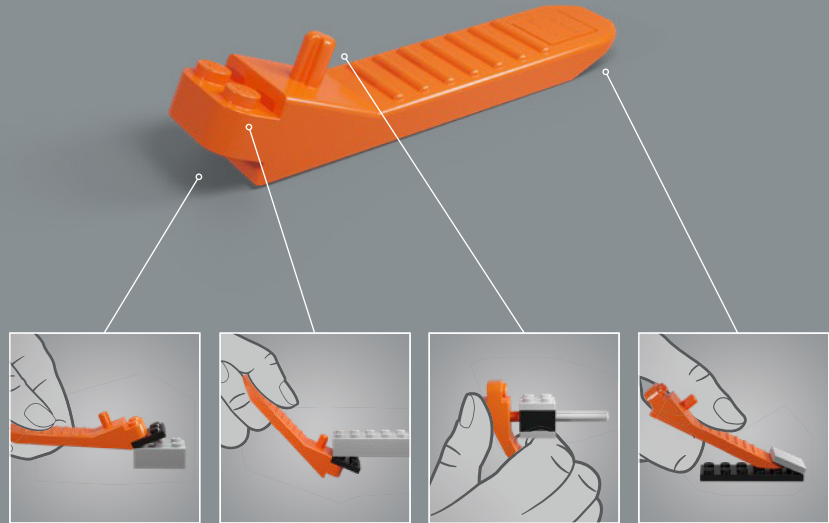

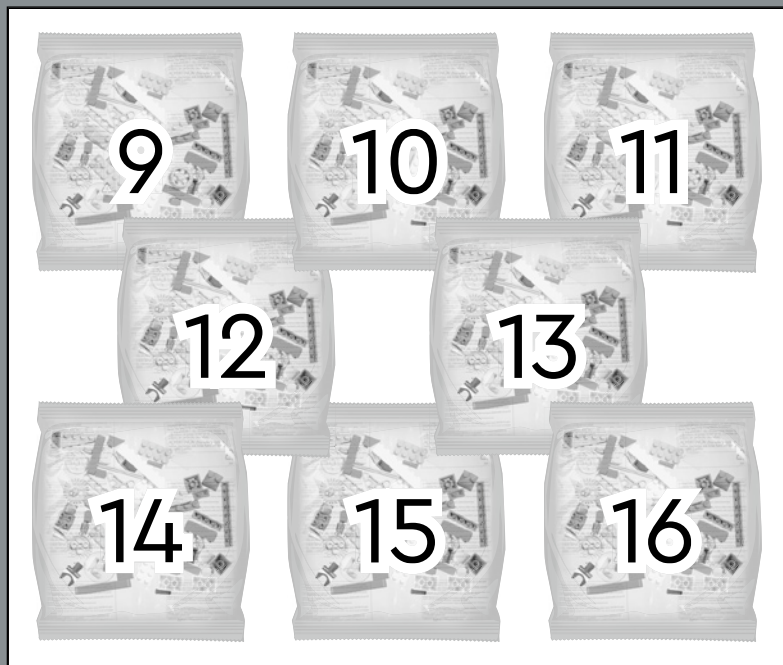
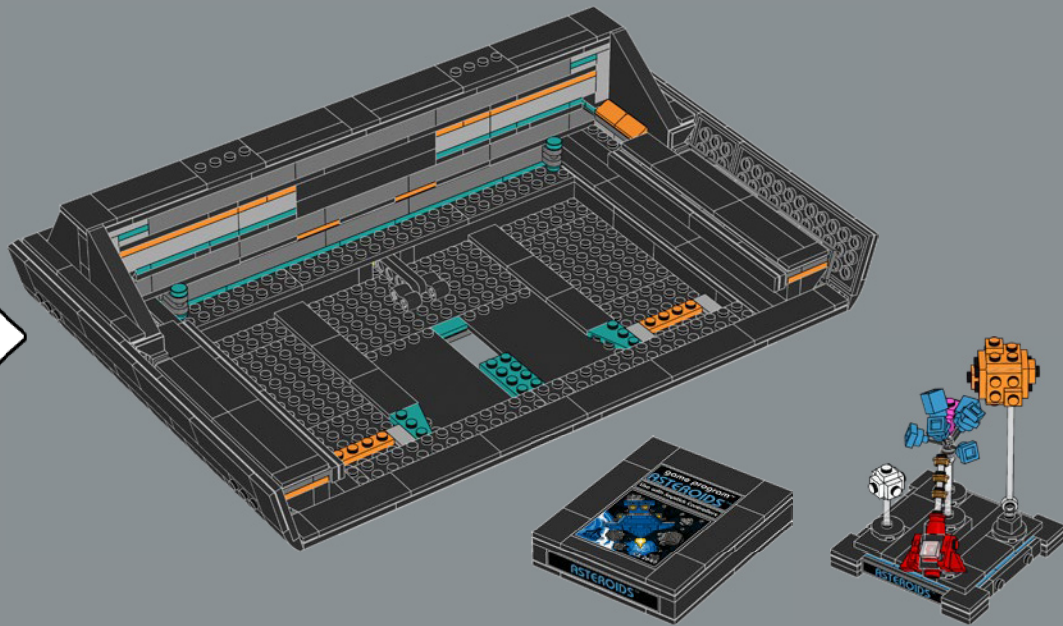

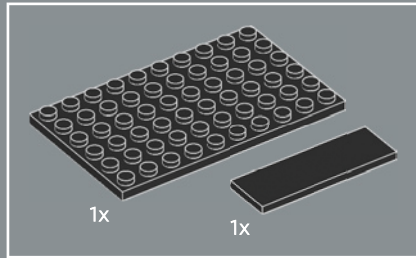
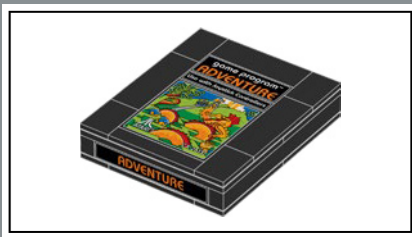

1

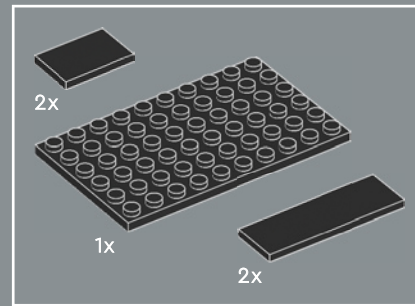
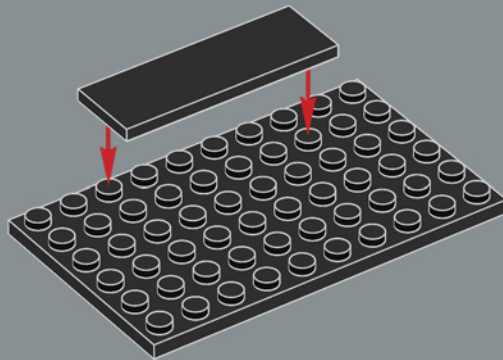

2

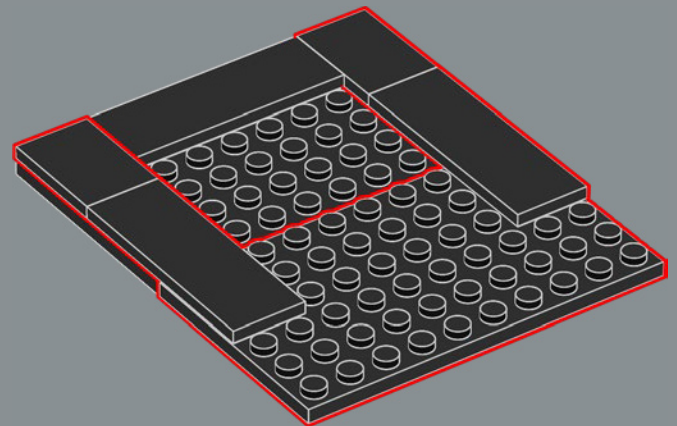

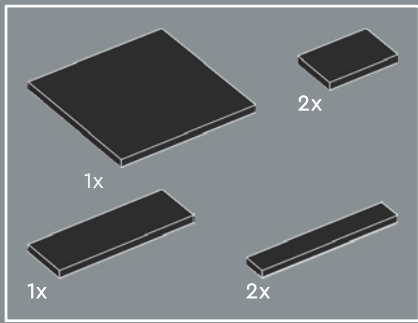

3

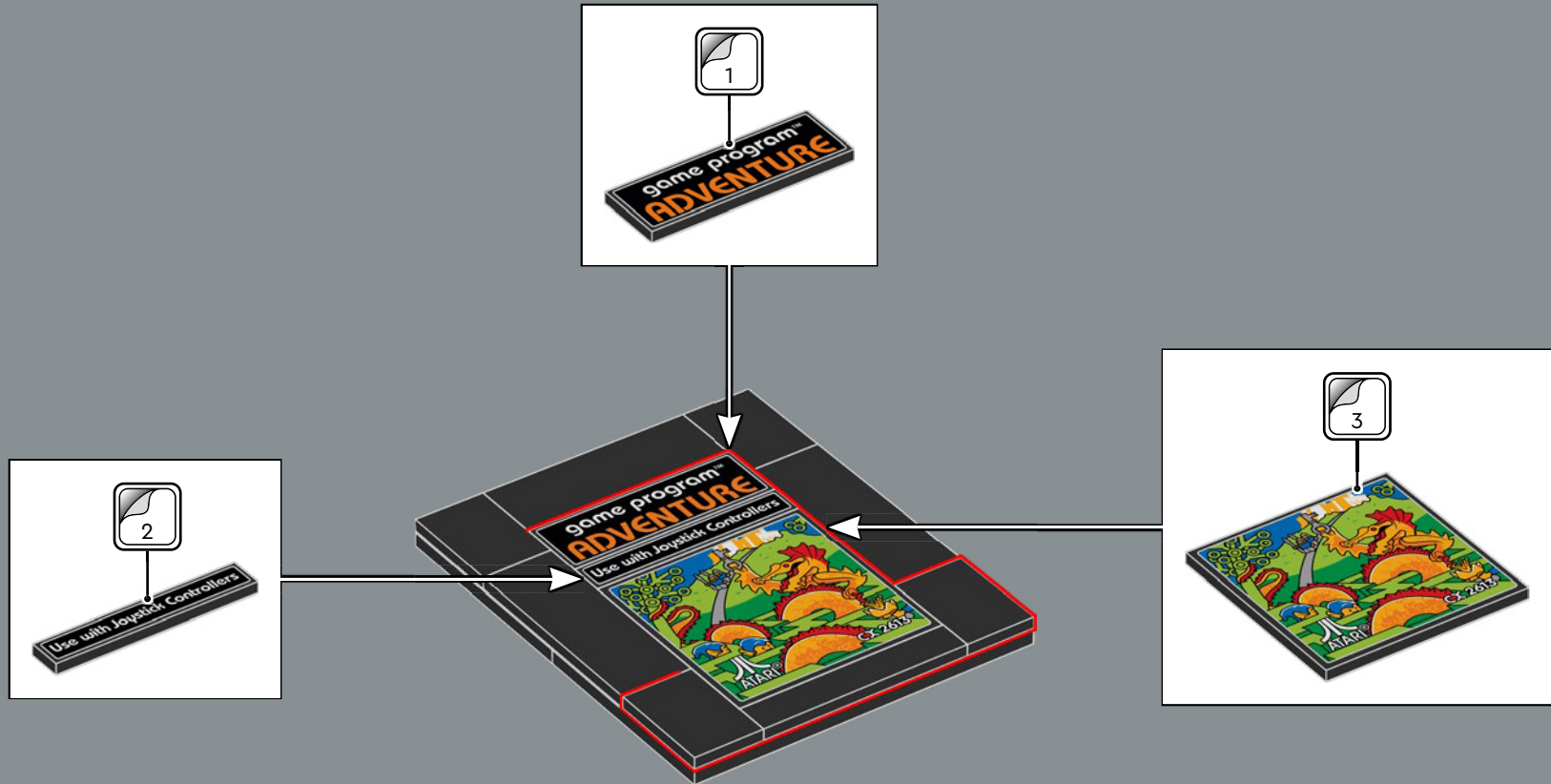

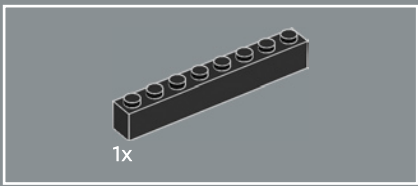

4

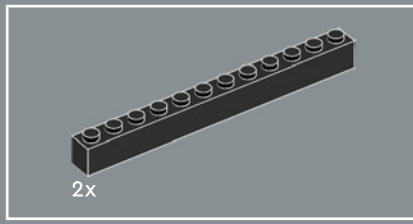
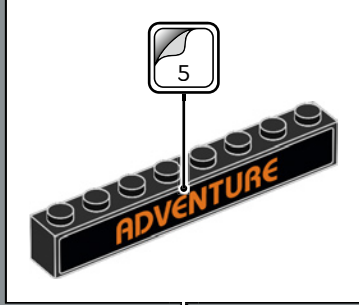

5

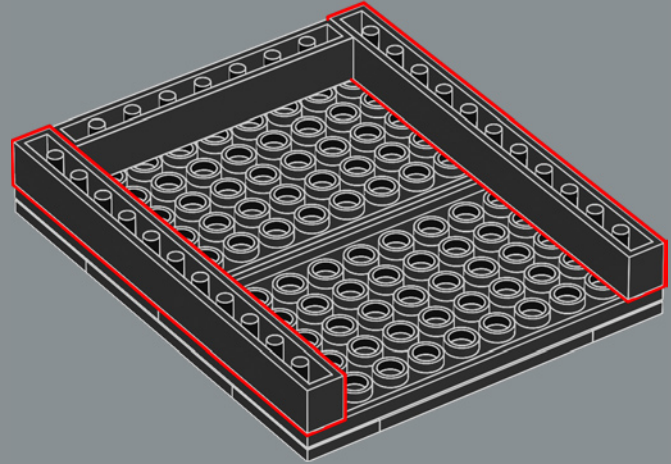

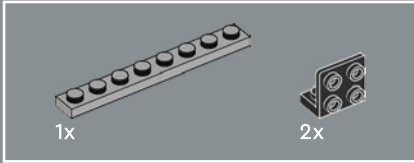
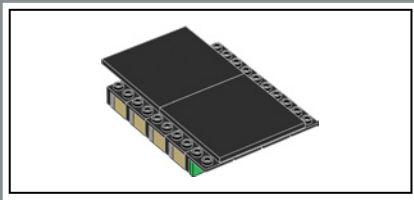

6

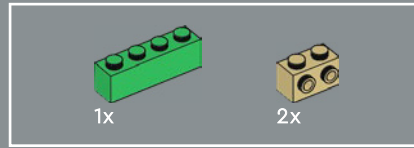
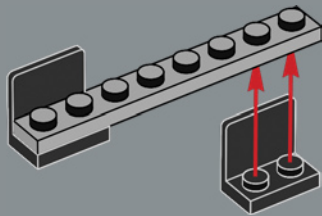

7

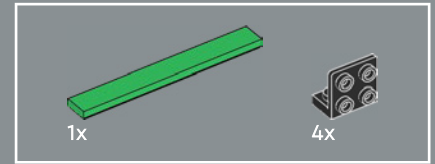
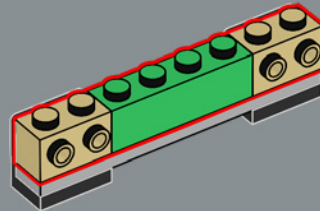

8

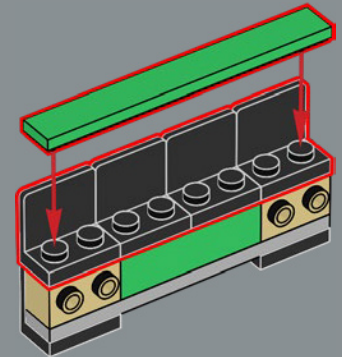

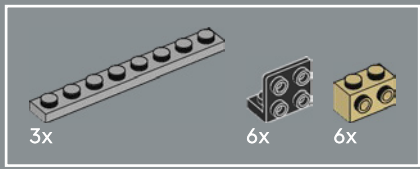

9

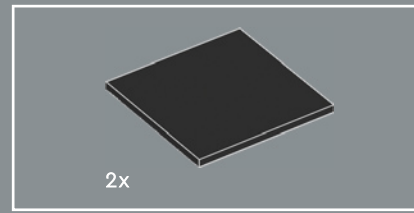
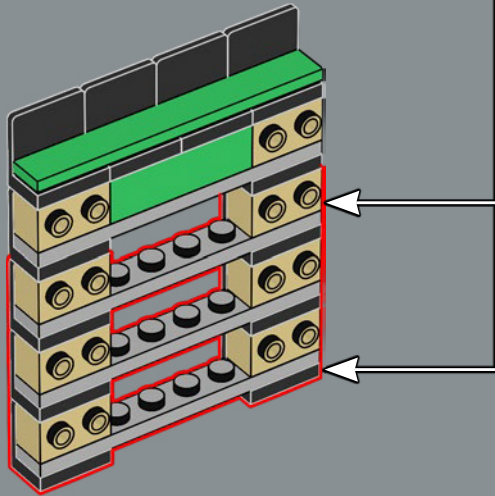
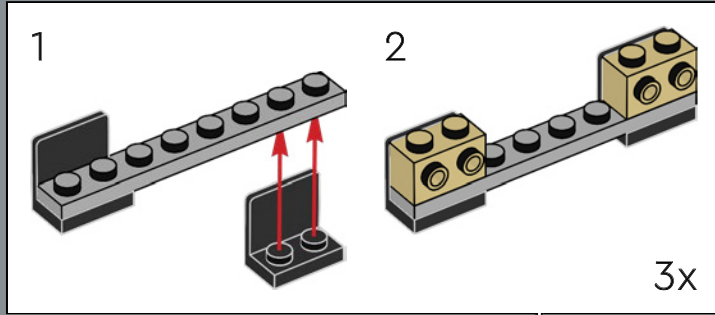

10

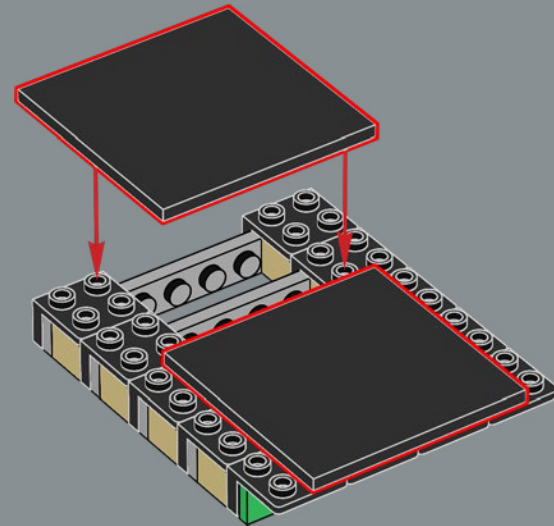

11

Many of the first ATARI® Video Computer System game cartridges used just 2k of data. That's roughly equivalent to a single page of text.

Bon nombre des premières cartouches de jeux de la console ATARI® n'utilisaient que 2 ko de données. C'est à peu près l'équivalent d'une page de texte.

Muchos de los primeros cartuchos de juego del ATARI® Video Computer System ocupaban solo 2 kB de datos. Es más o menos lo mismo que ocupa una página de texto.

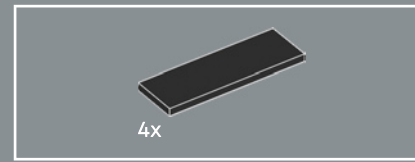
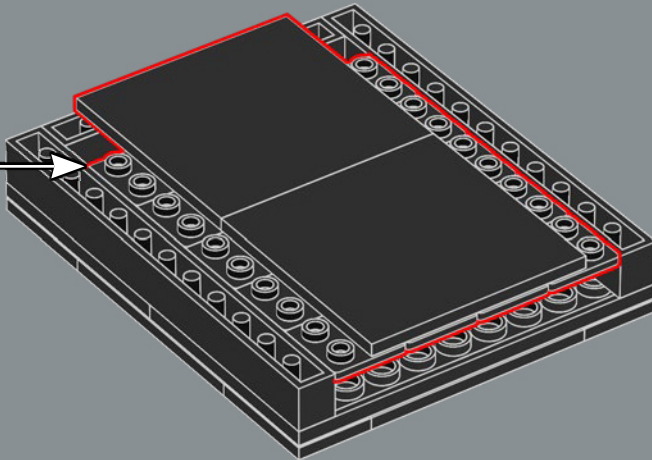

12

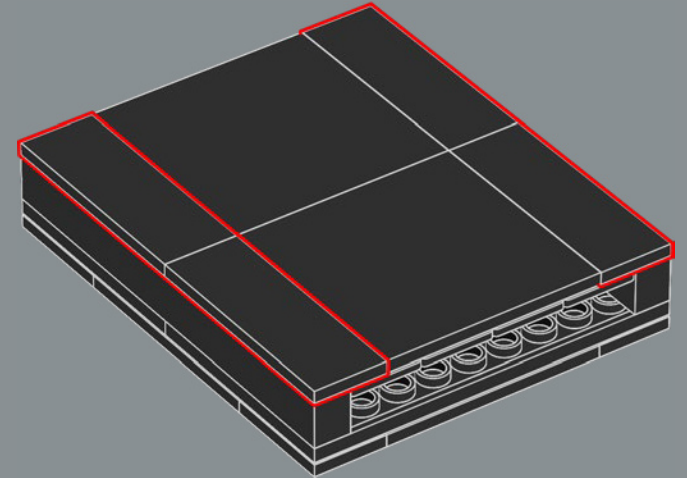

13



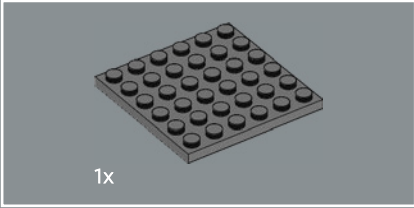
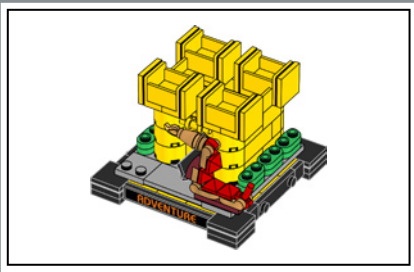

1

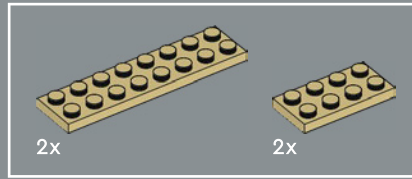
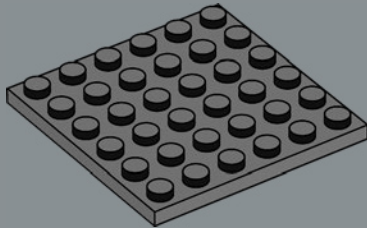

2

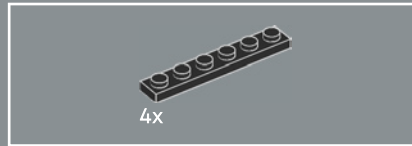
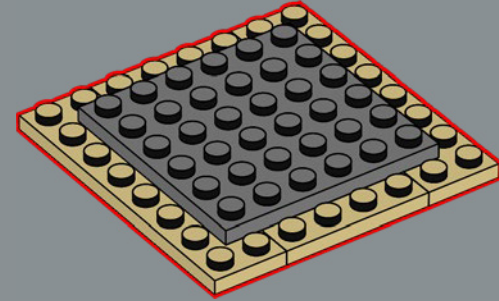

3

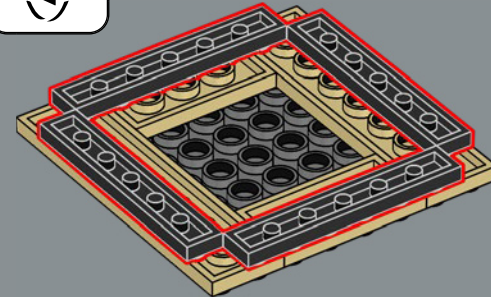

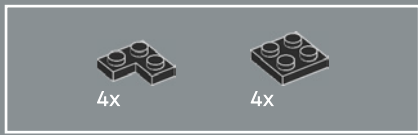

4

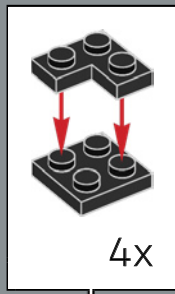
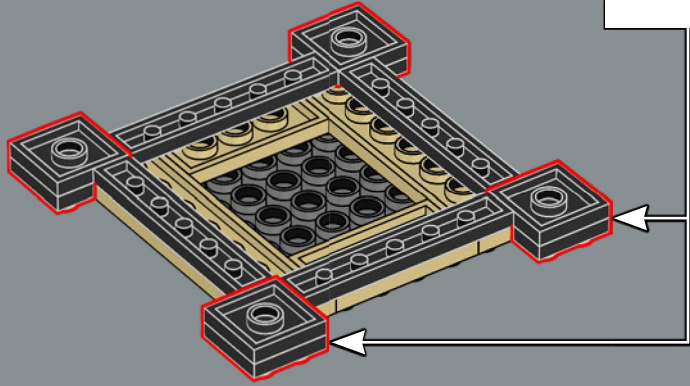

4x

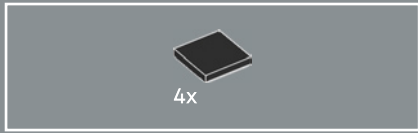

5

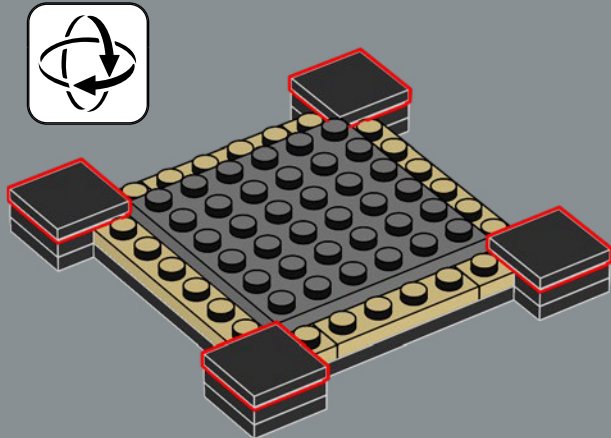

6

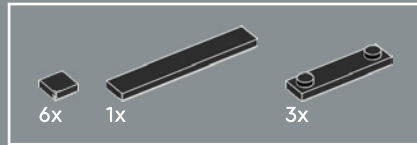
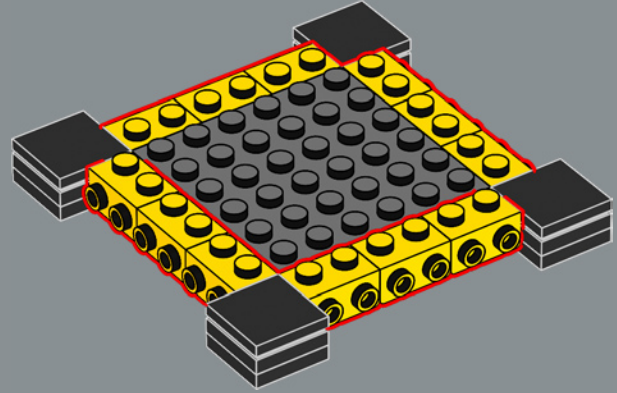

7

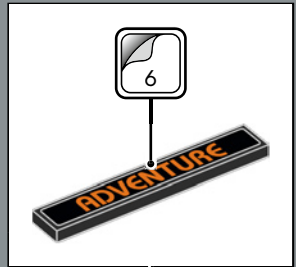
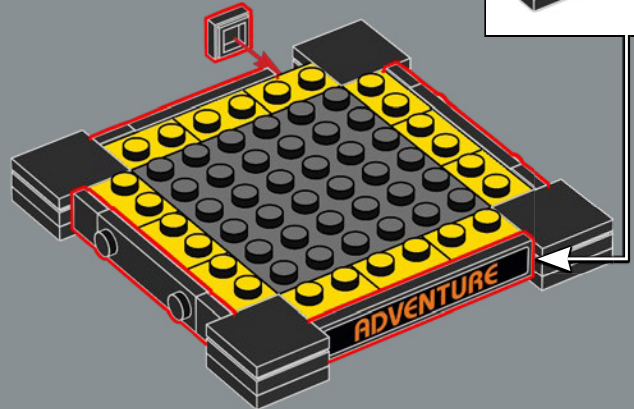

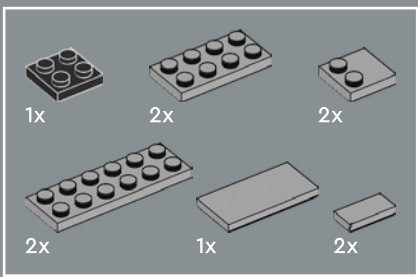

8

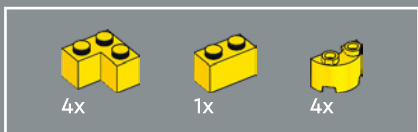
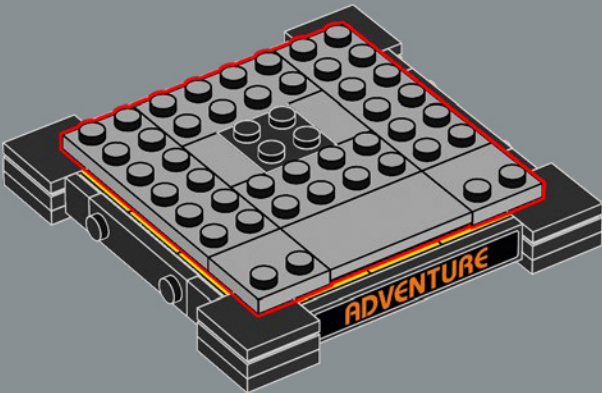

9

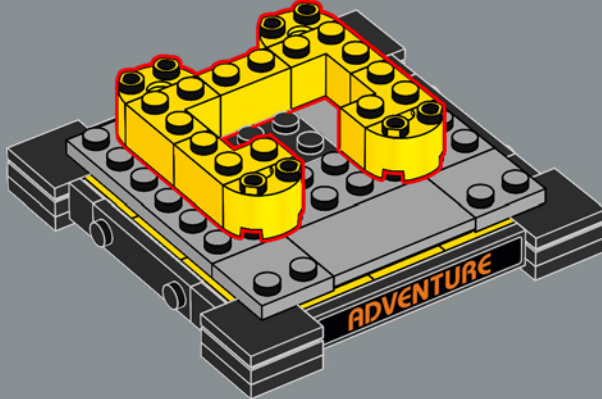

10

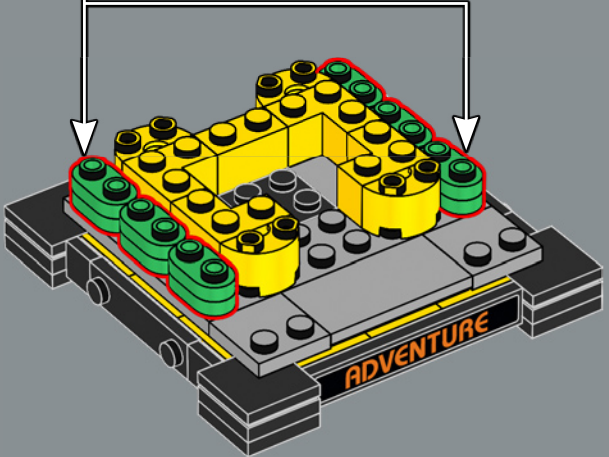
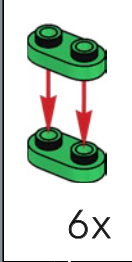



11

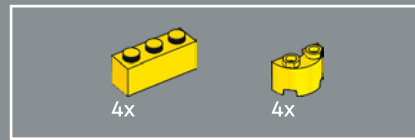
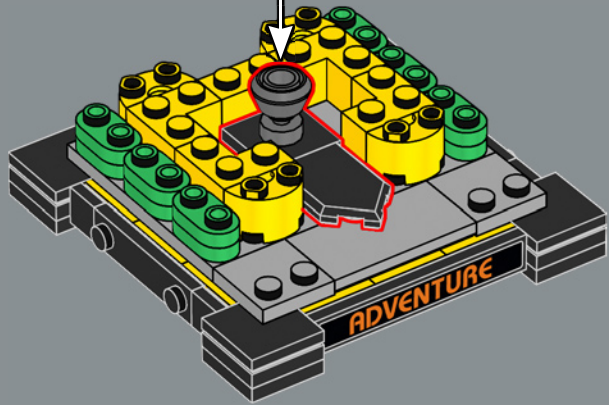
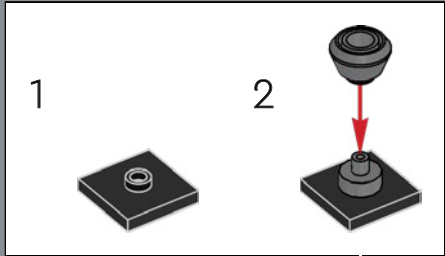

12

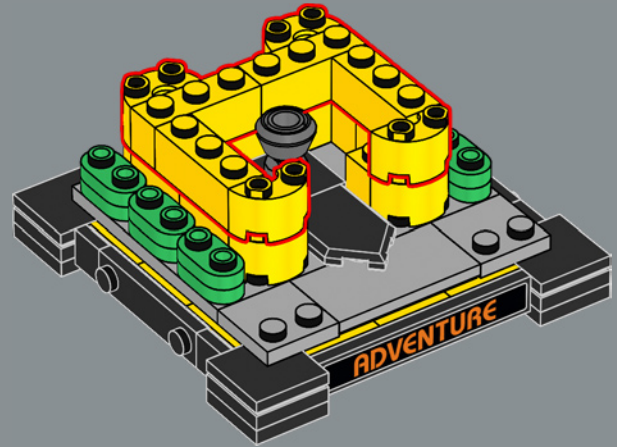

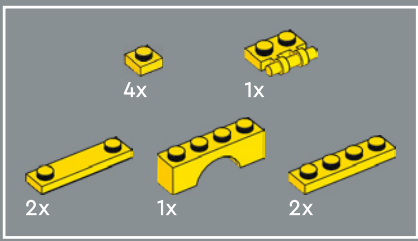

13

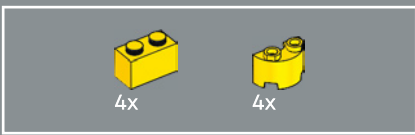
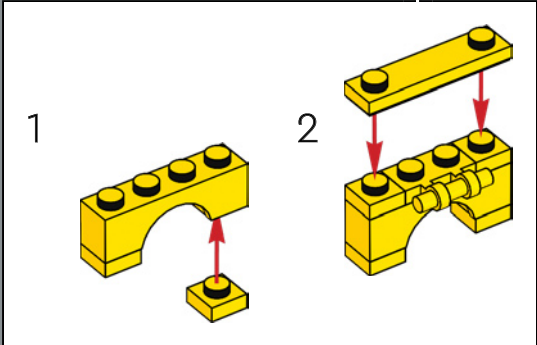
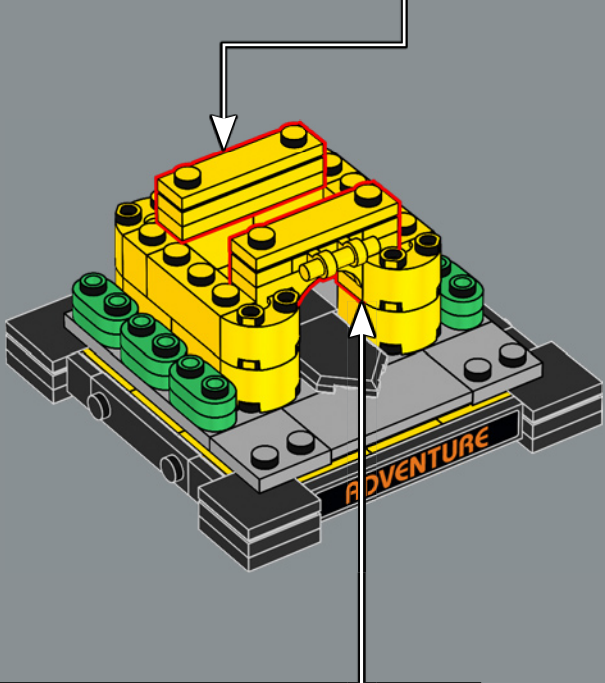
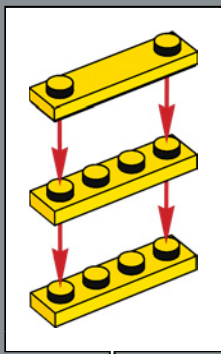

14

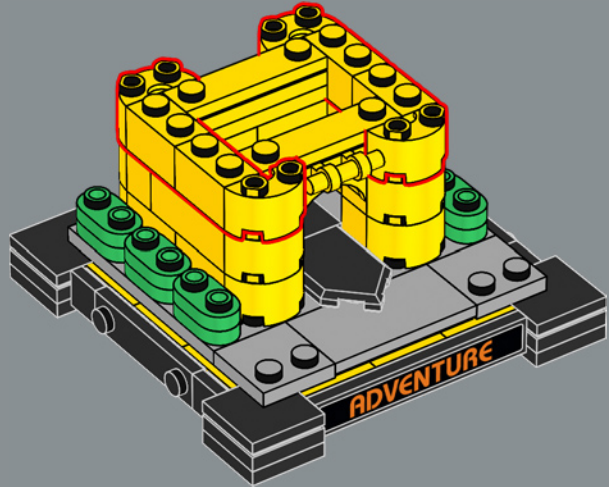

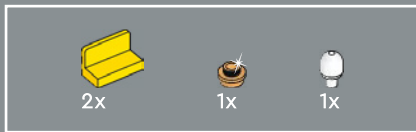

15

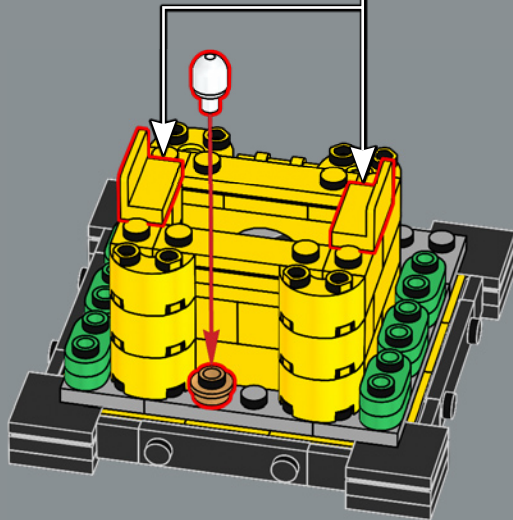
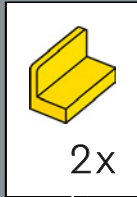

The Adventure vignette includes a small nest with egg at the back of the castle. This is a nod to the fact that Adventure features the first-ever Easter egg in a video game.

La vignette Adventure comprend un petit nid avec un œuf à l'arrière du château. C'est un clin d'œil au fait qu'Adventure renferme le tout premier œuf de Pâques dans un jeu vidéo.

La viñeta de Adventure incluye un pequeño nido con un huevo detrás del castillo. Es un guiño al hecho de que Adventure fue el primer videojuego de la historia en incluir un huevo de Pascua.

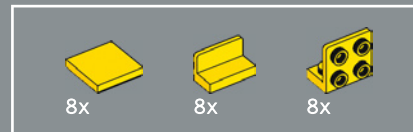

16

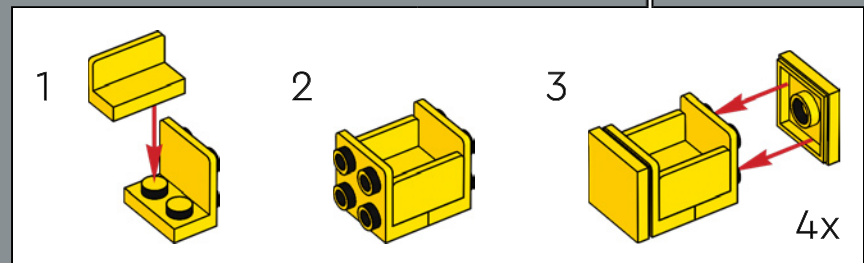
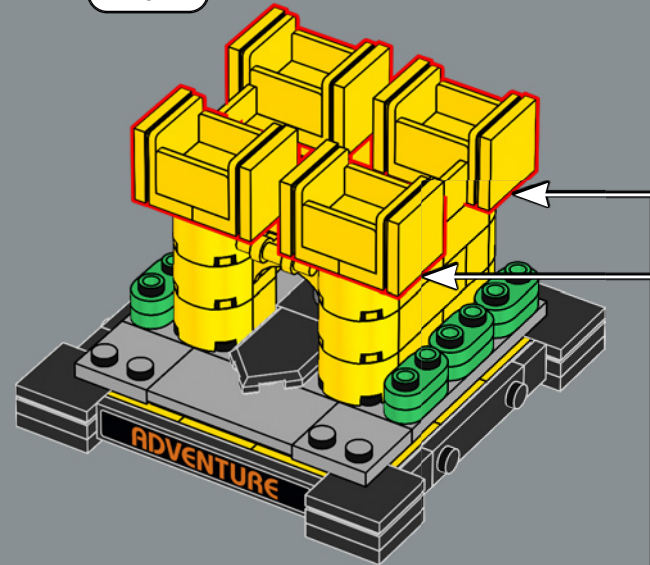

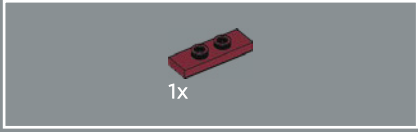

17

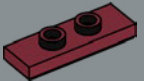

18

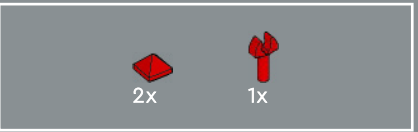

19



20

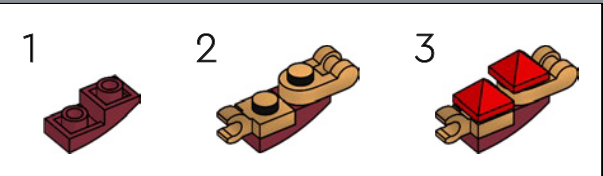



21

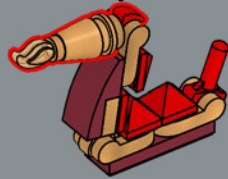
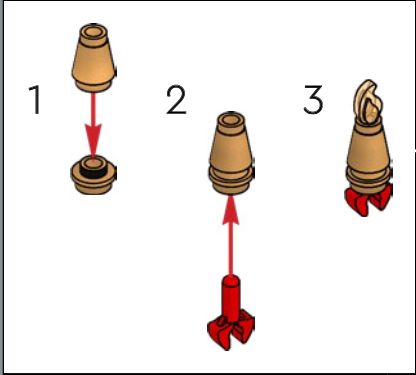

22

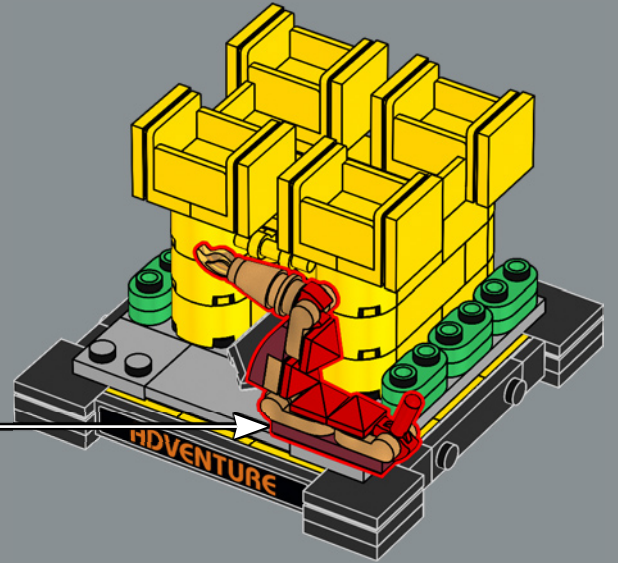

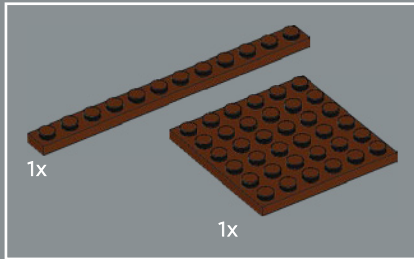
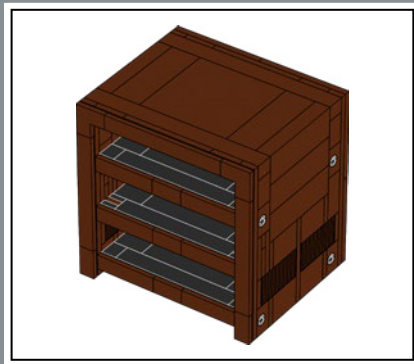

1

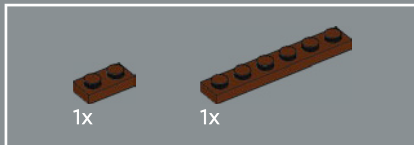
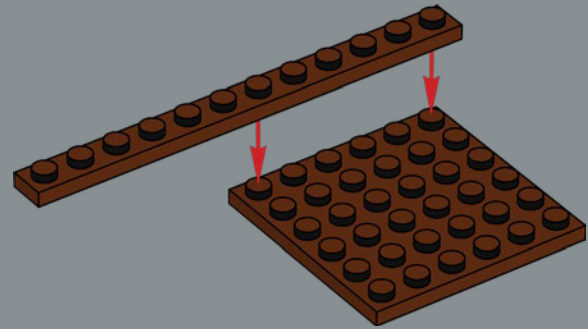

2

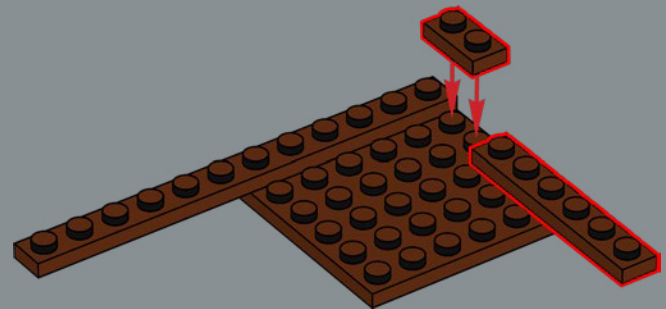

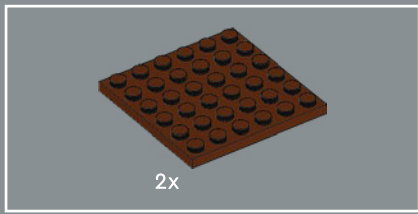

3

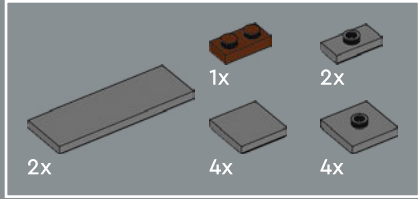
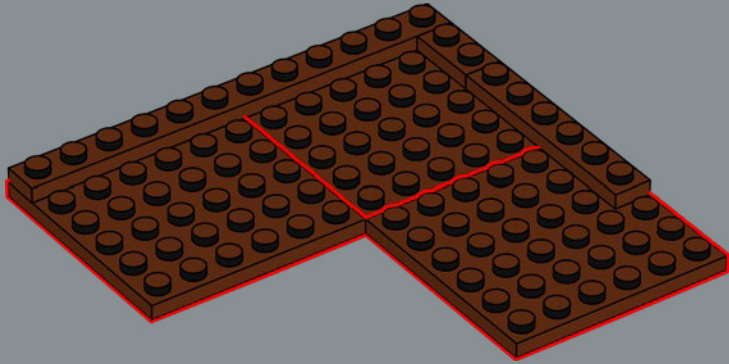

4

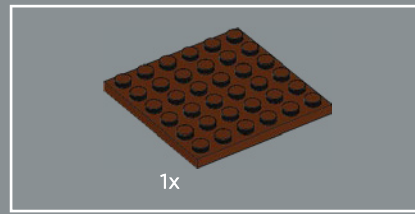
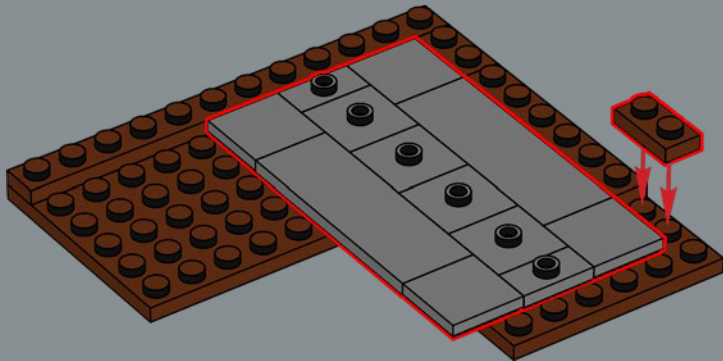

5

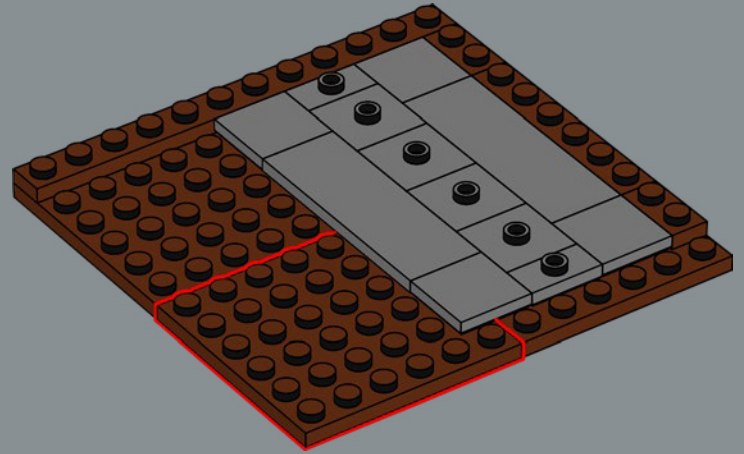

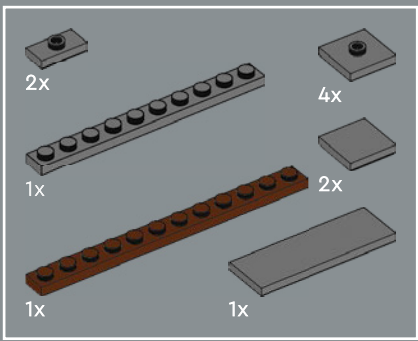

6

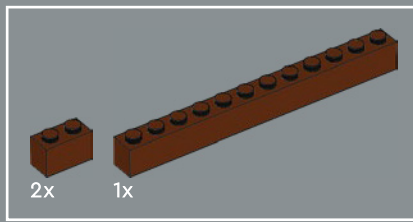
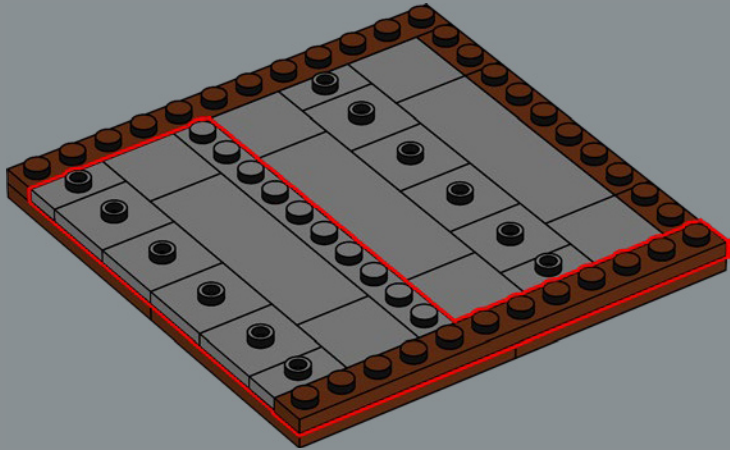

7

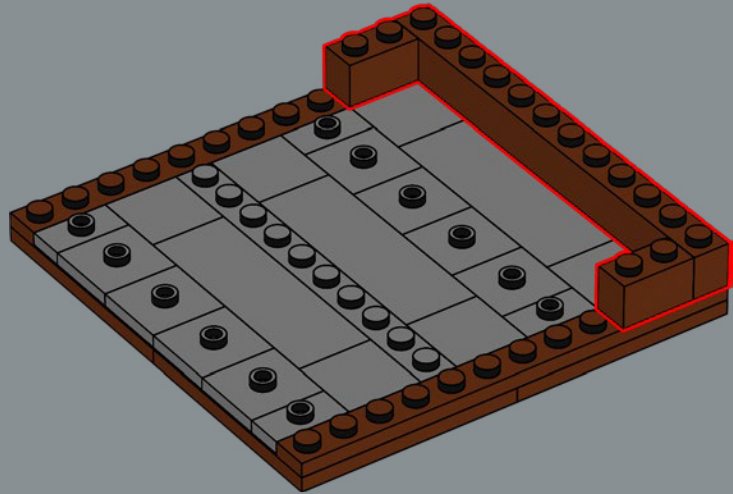

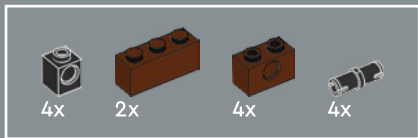

8

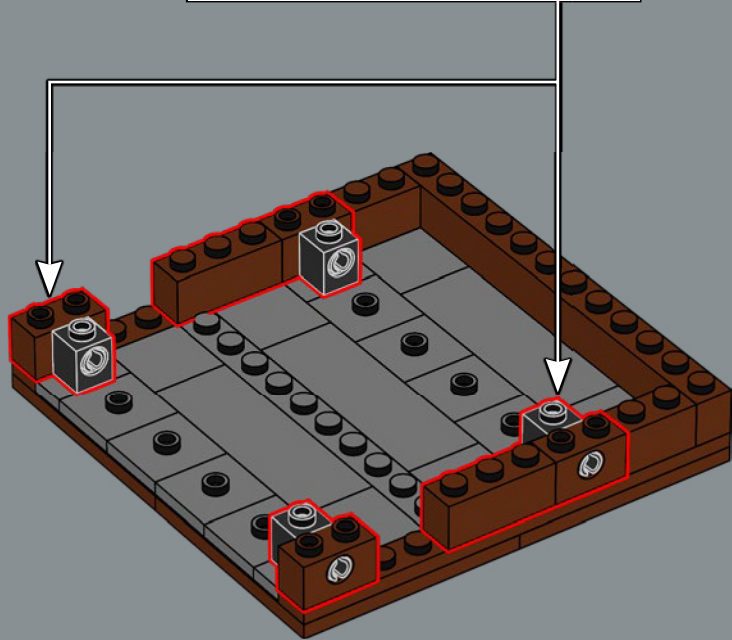
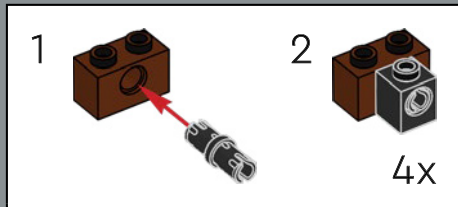

9

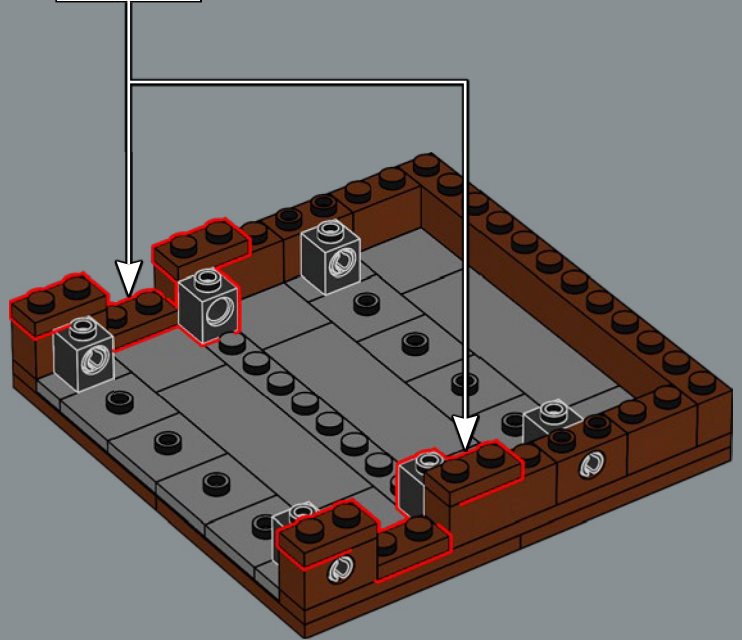
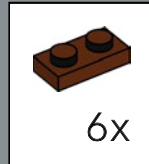

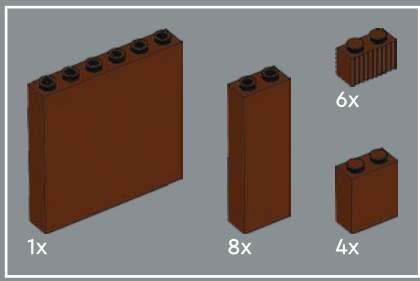

10

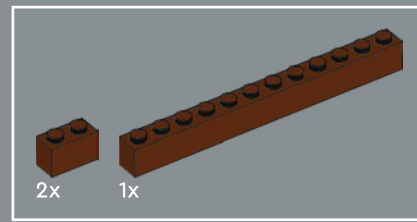
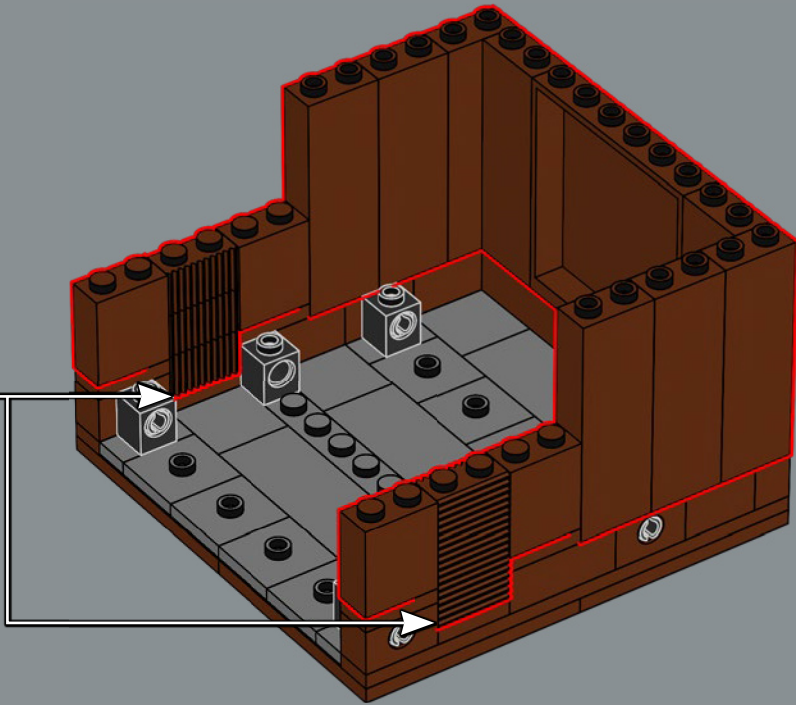
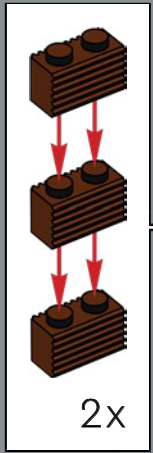

11

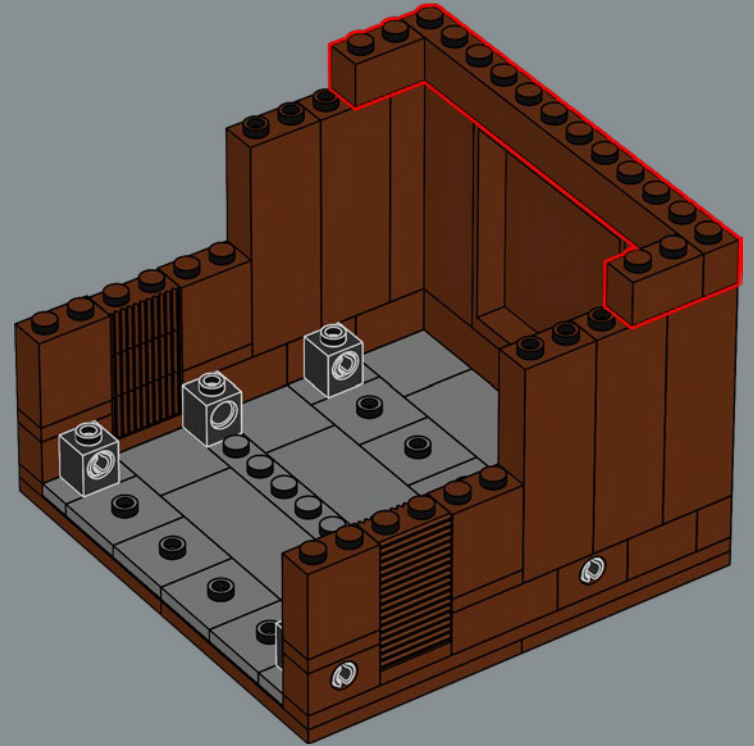

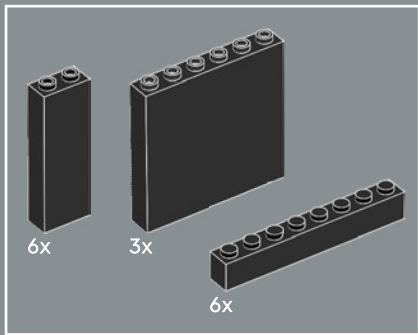

12

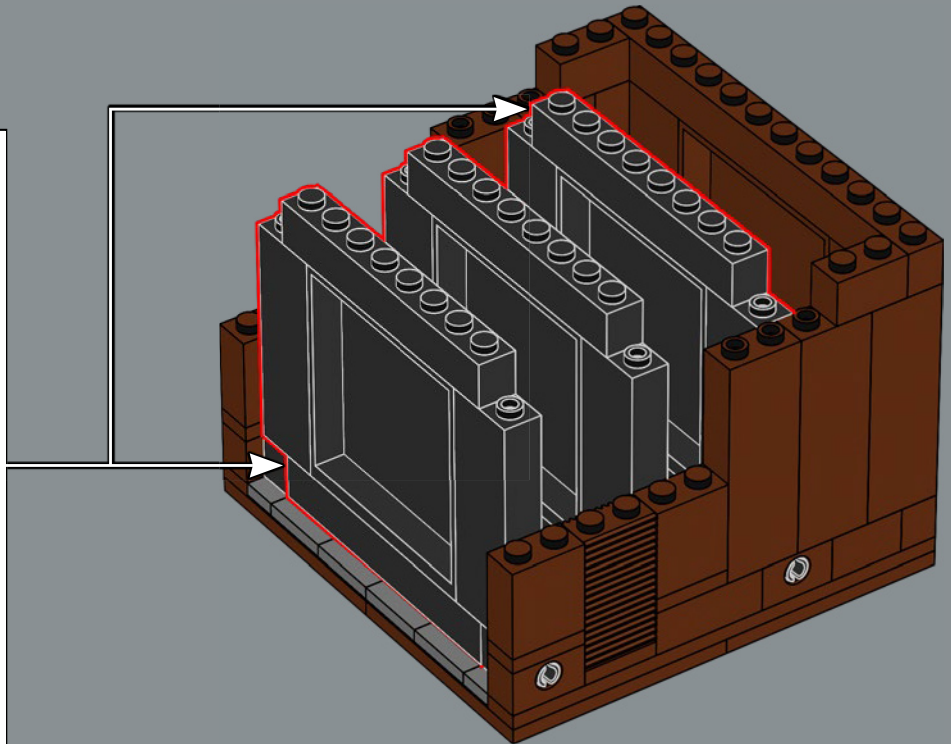
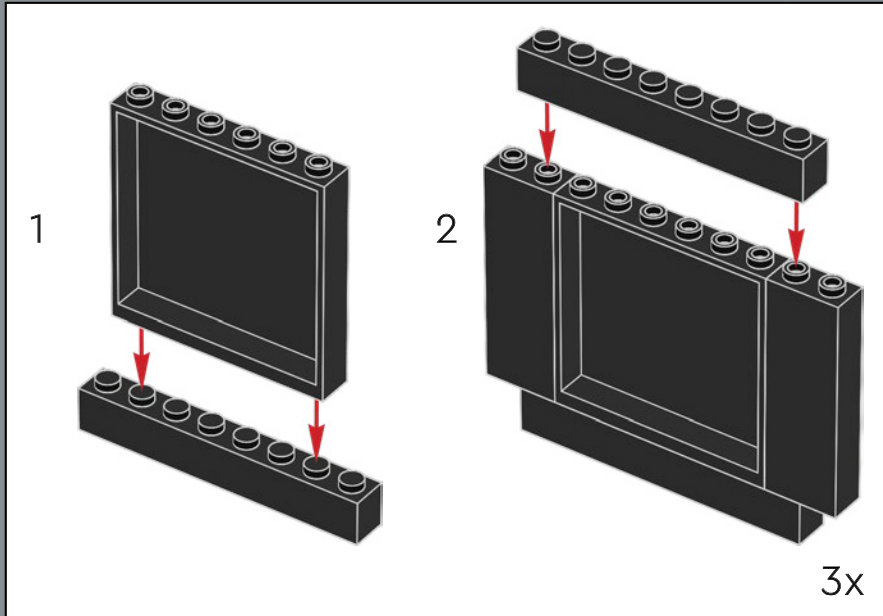

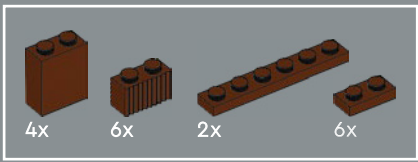

13

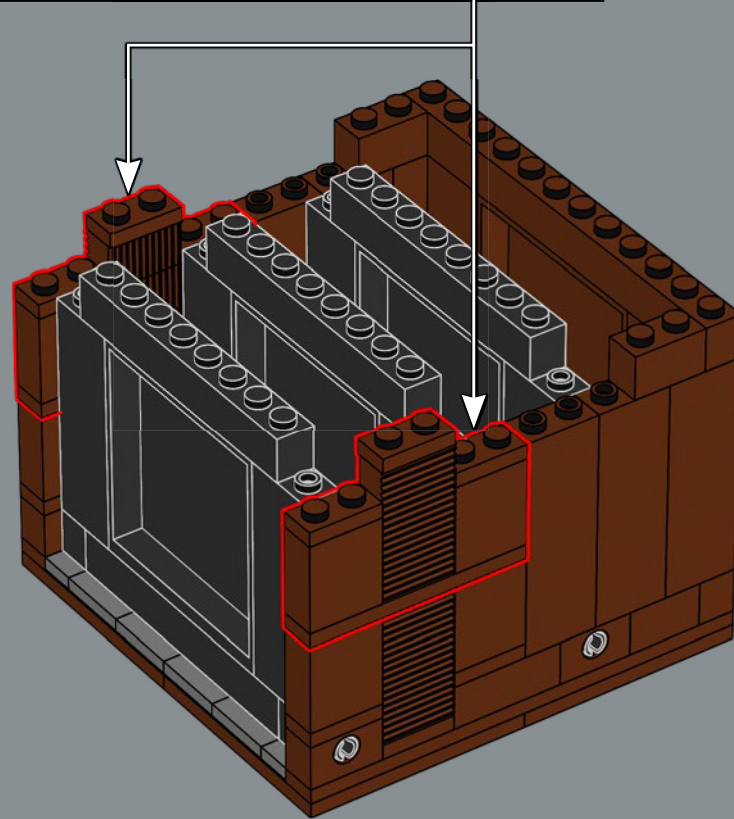
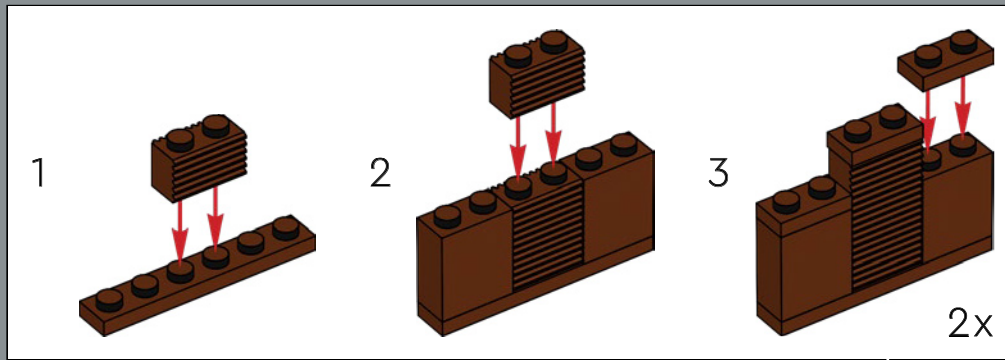

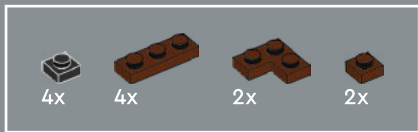

14

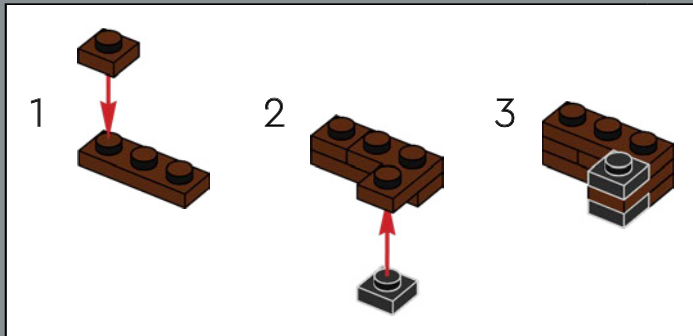
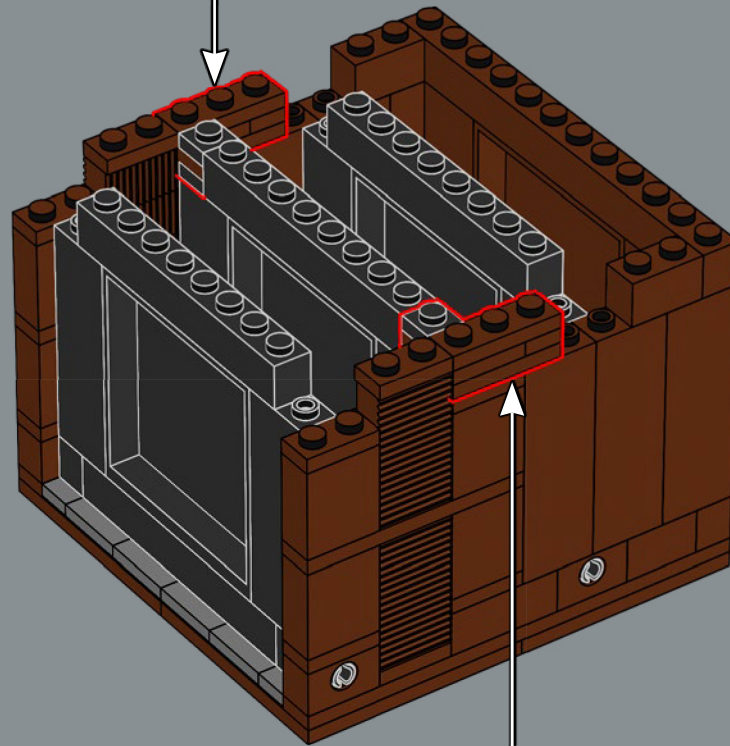
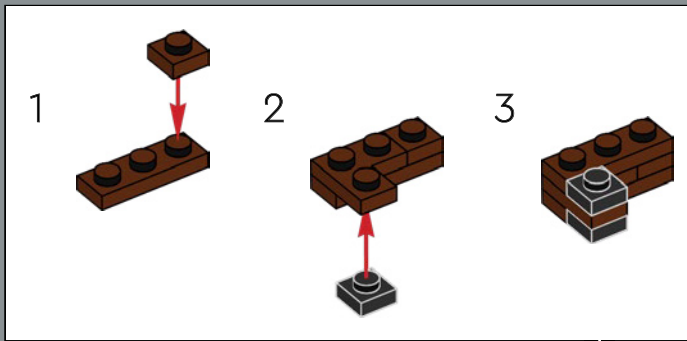

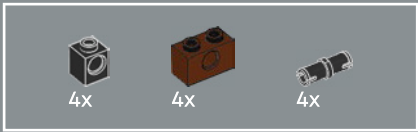

15

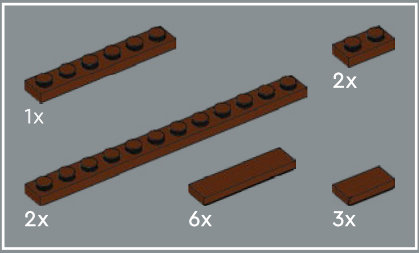
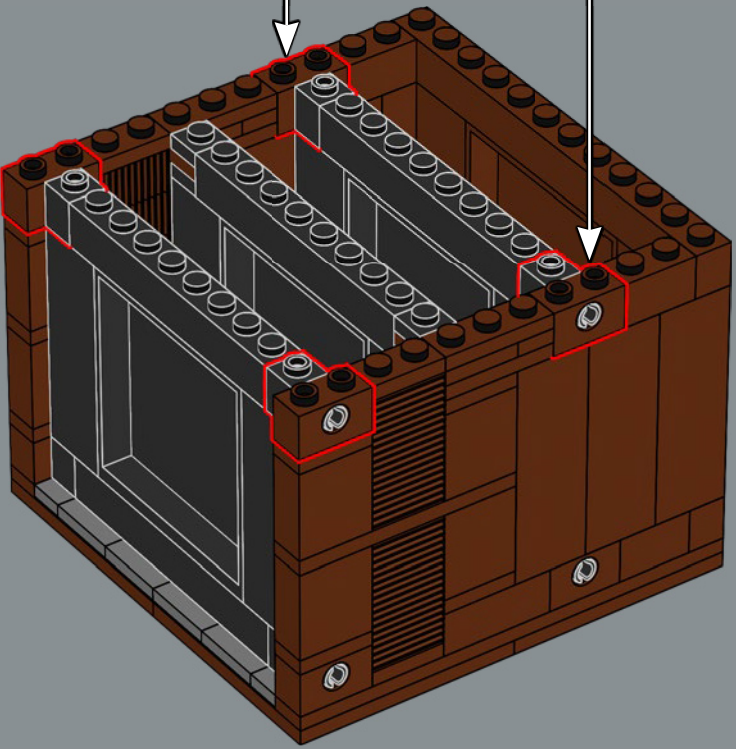
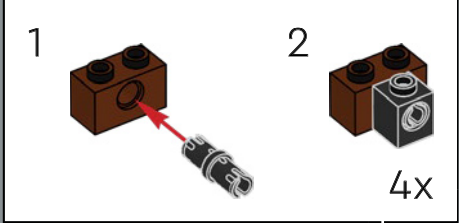

16

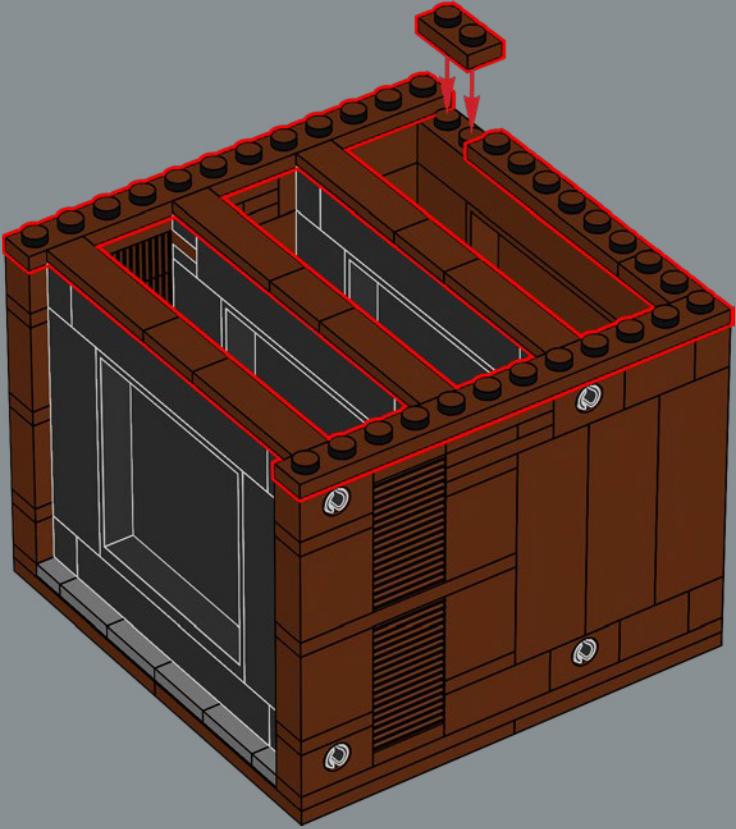

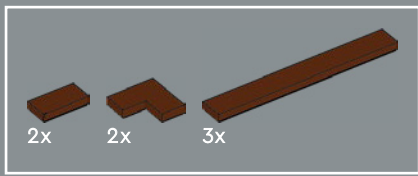

17

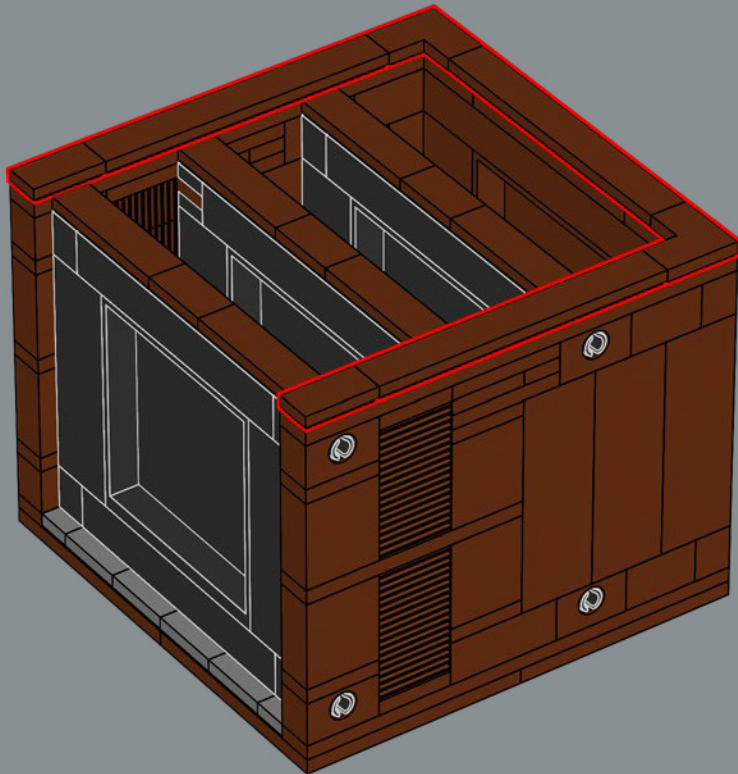

18

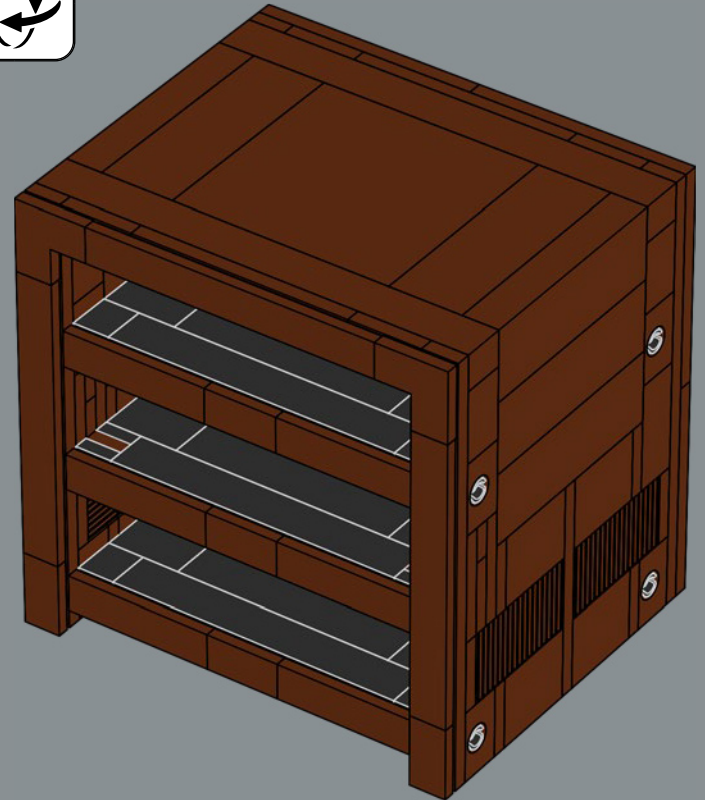

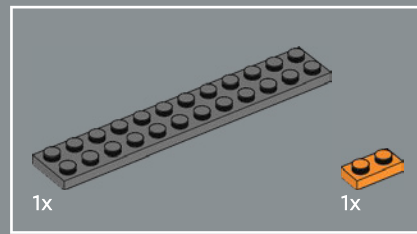
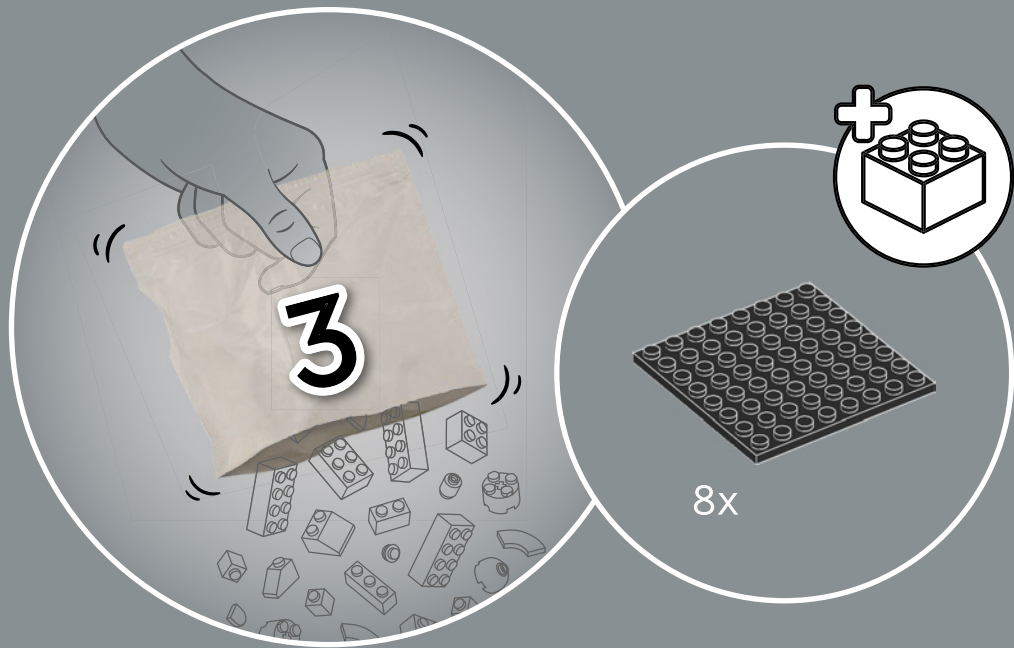

1

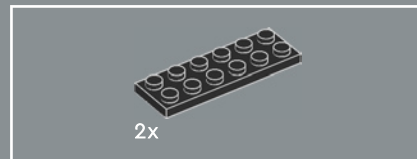
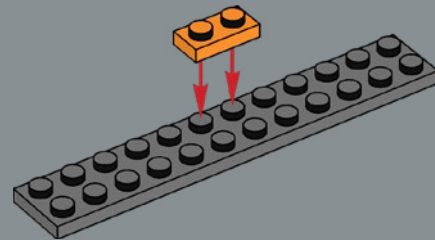

2

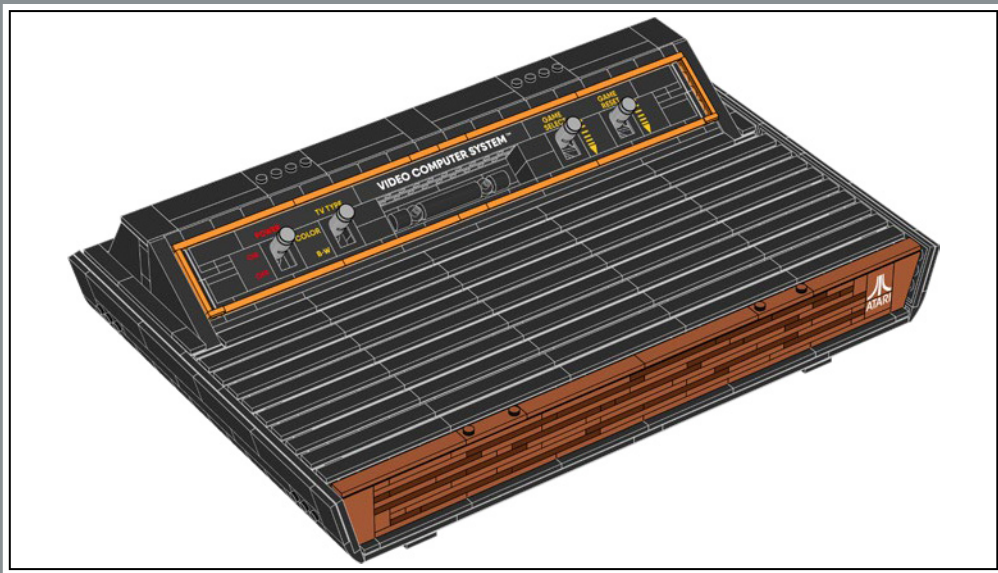
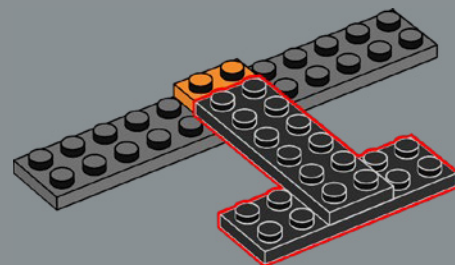

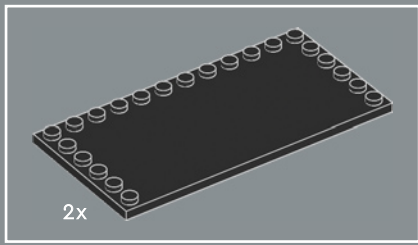

3

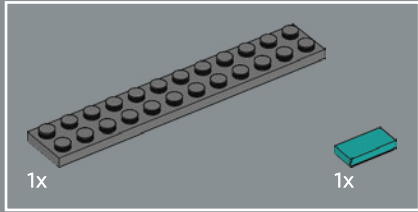
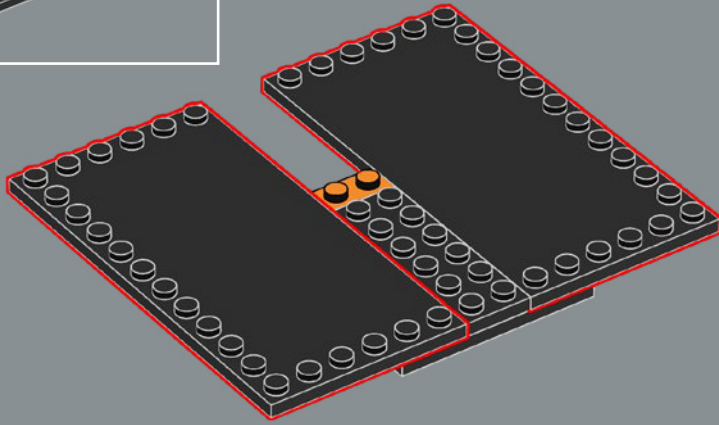

4

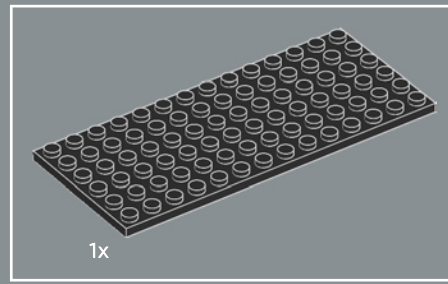
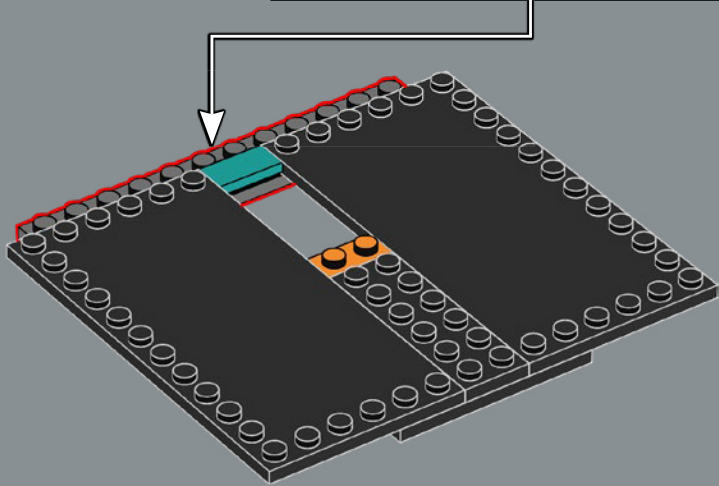
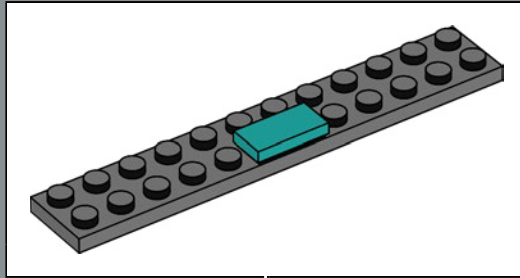

5

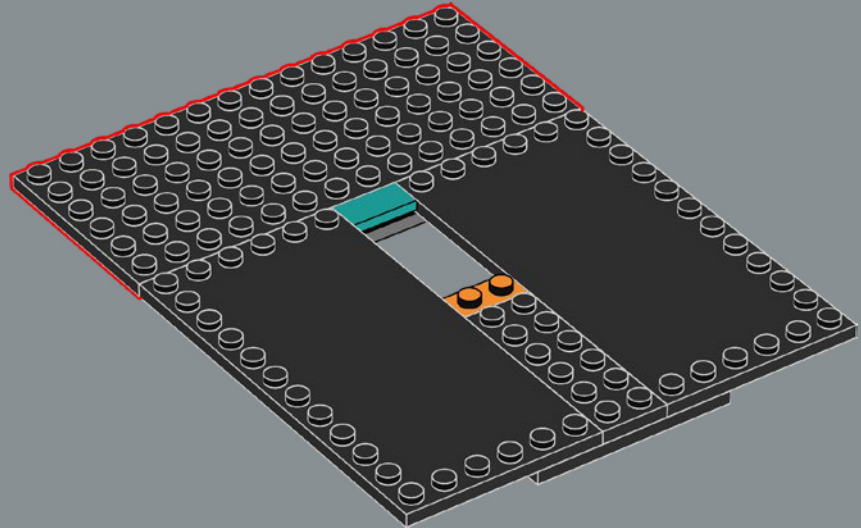

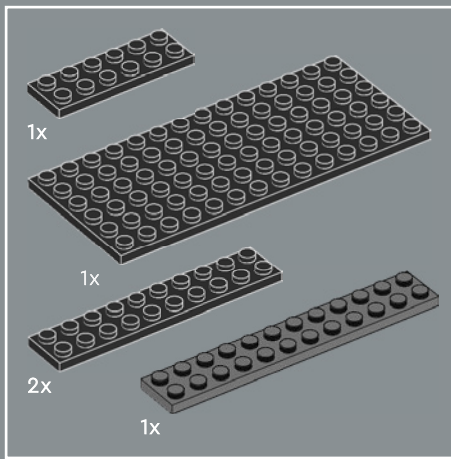

6

1

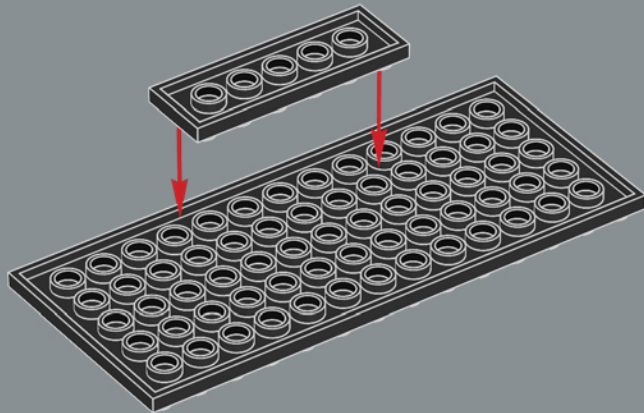

2

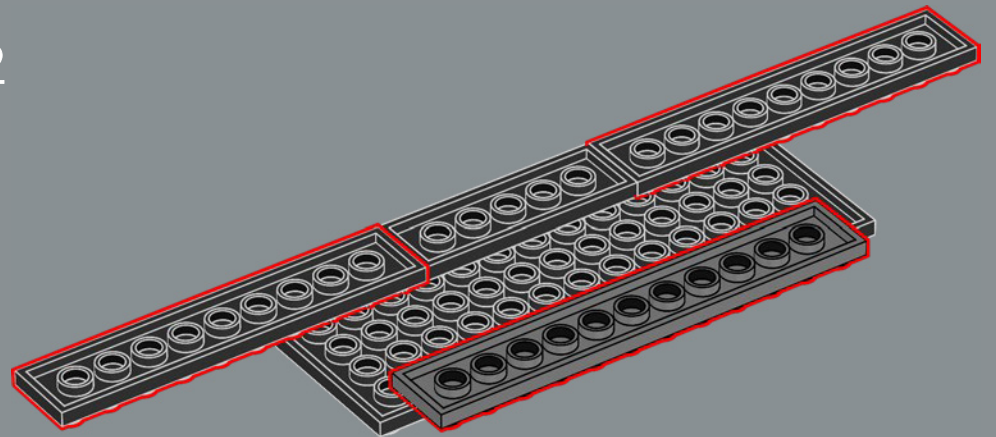

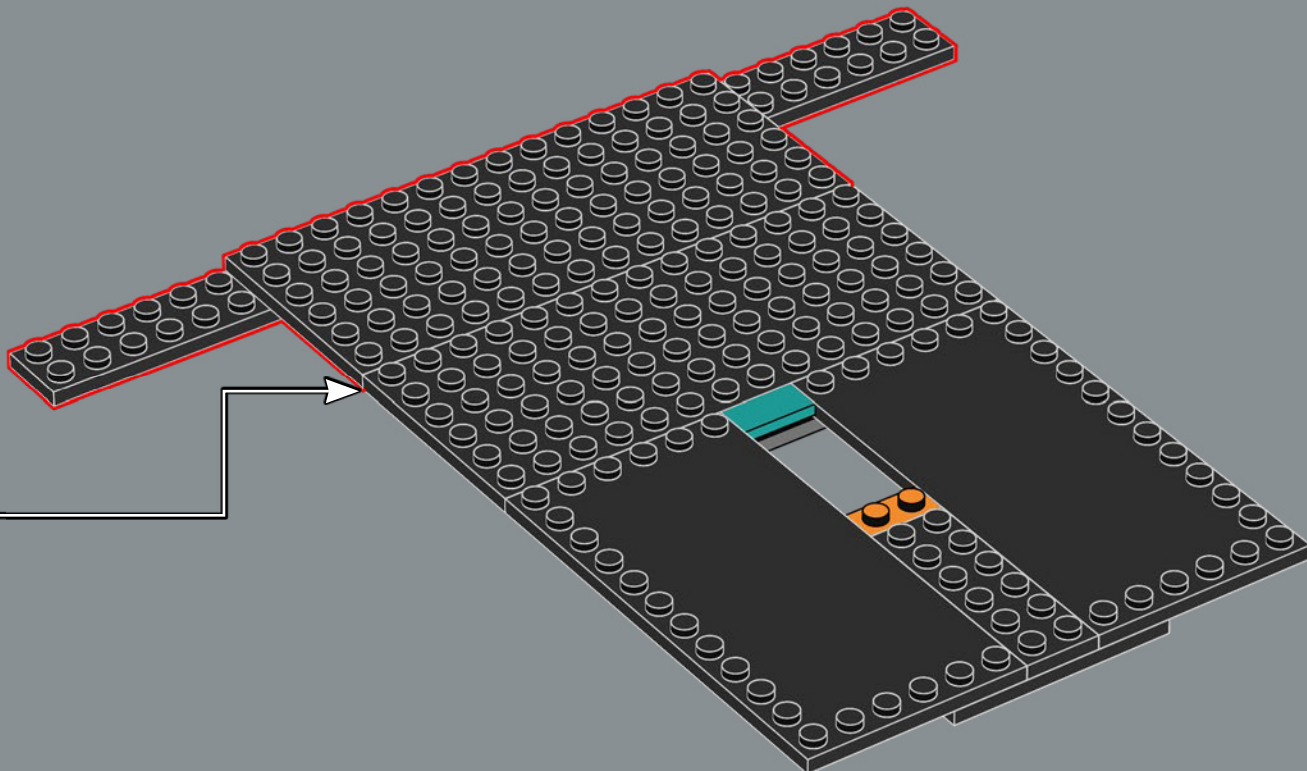

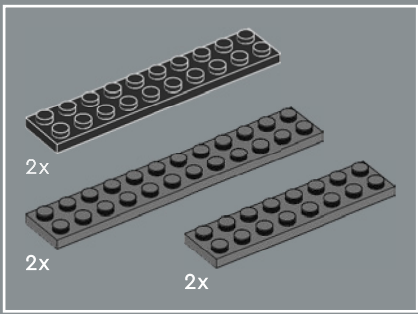

7

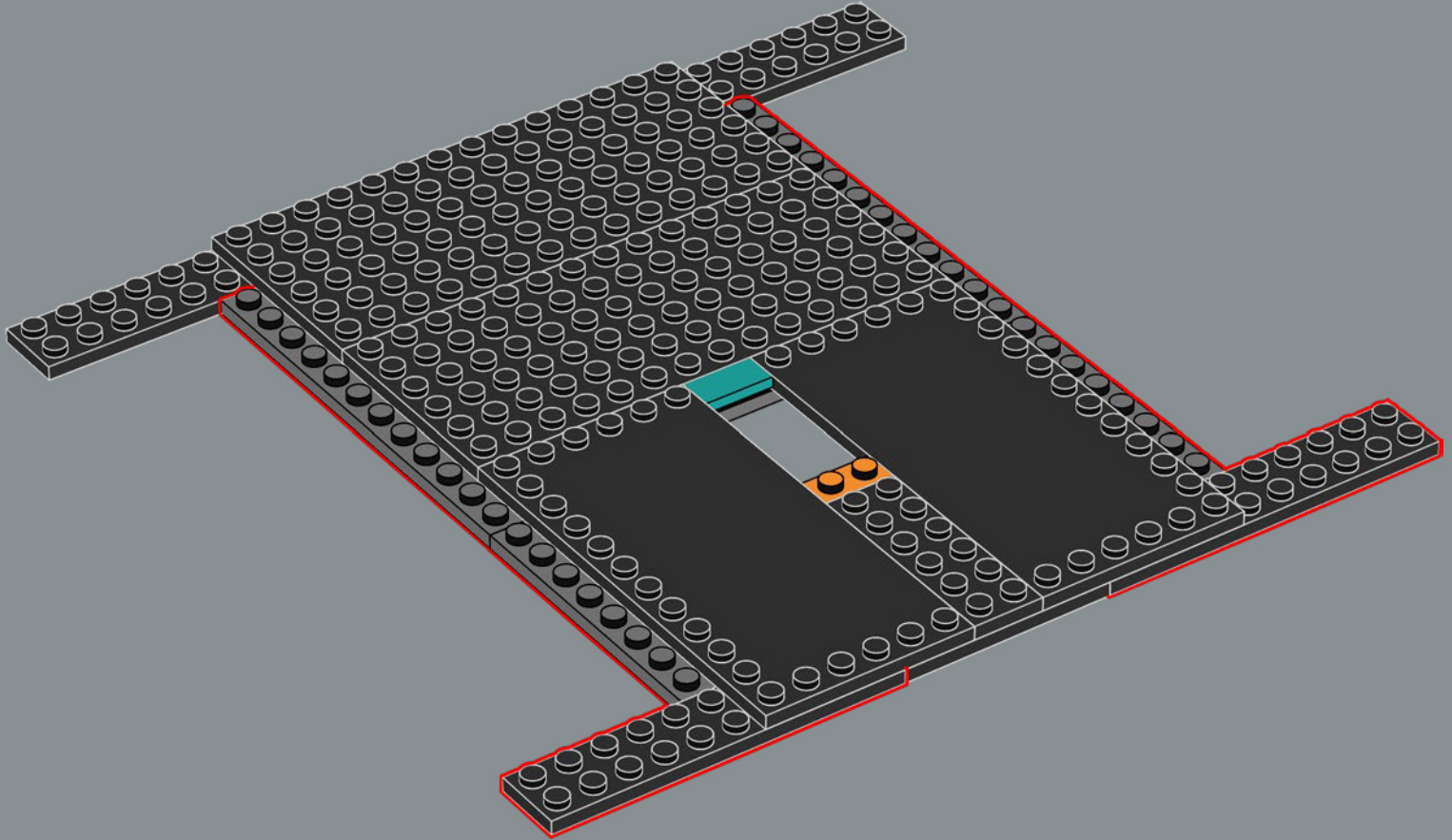

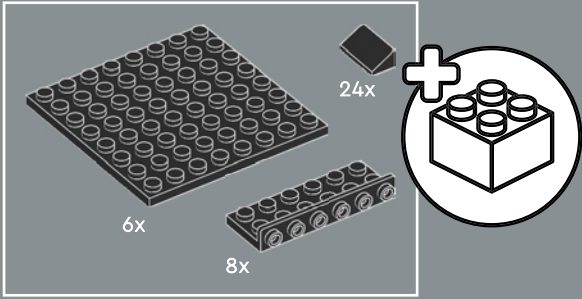
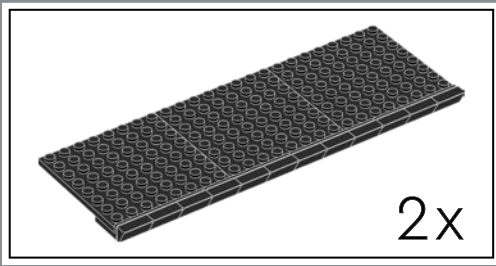

8

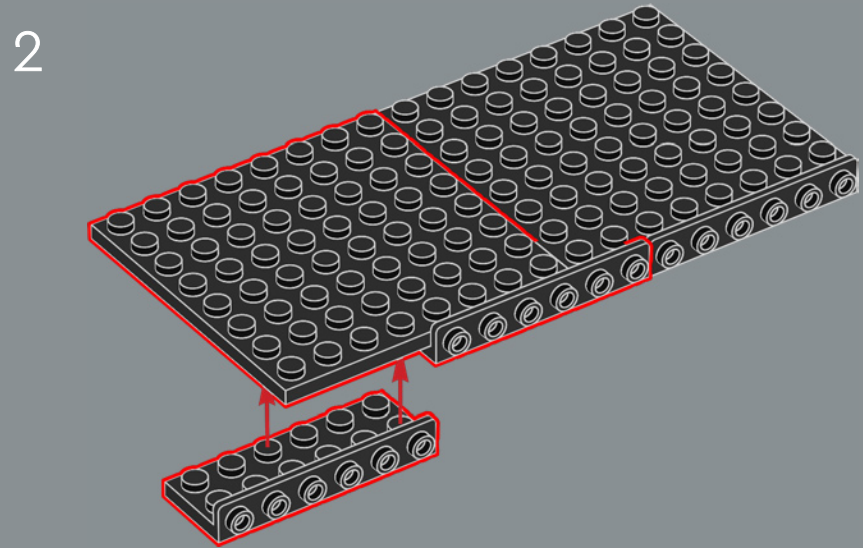
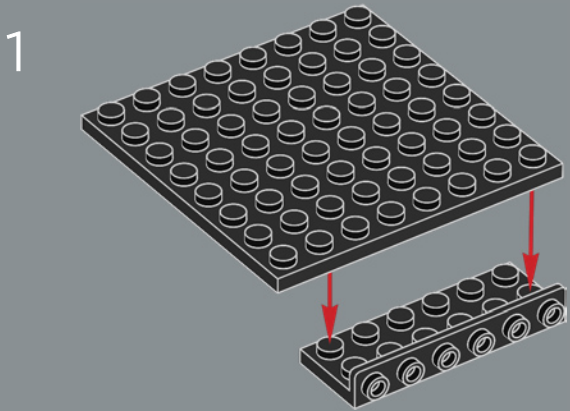

3

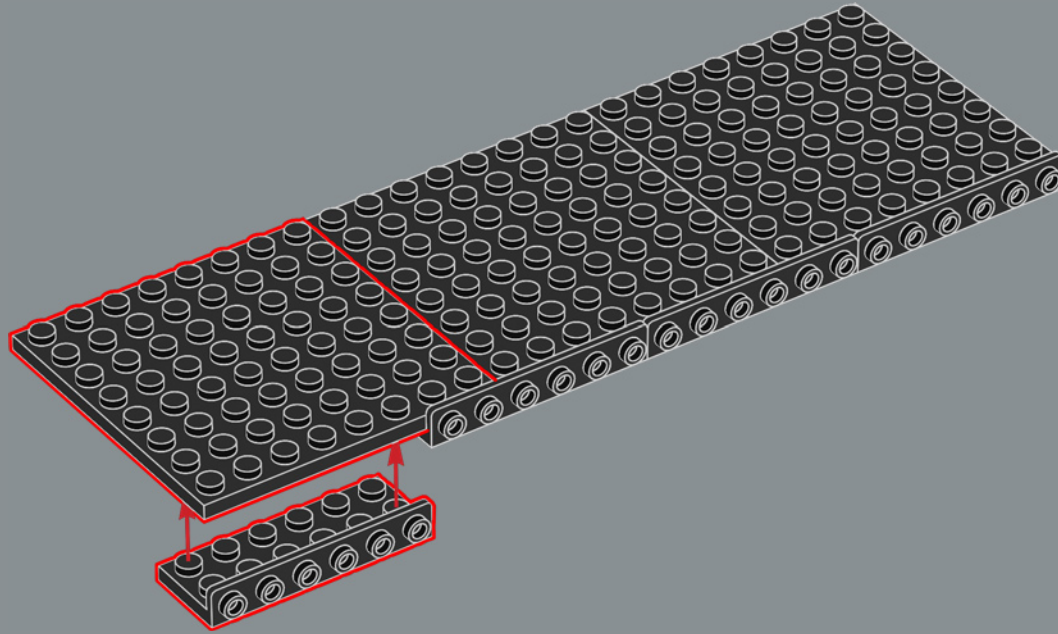

4

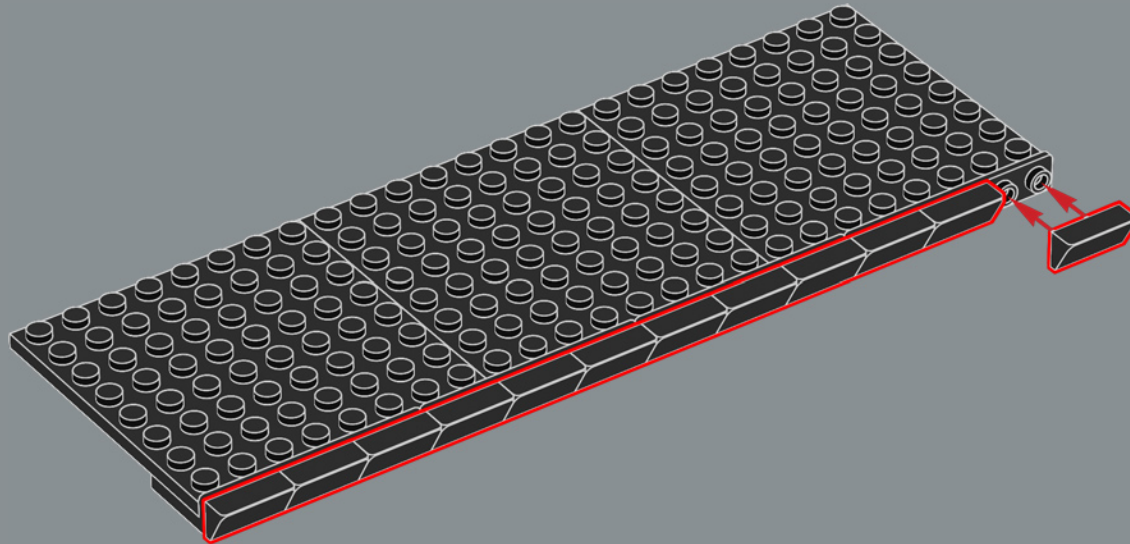

2x

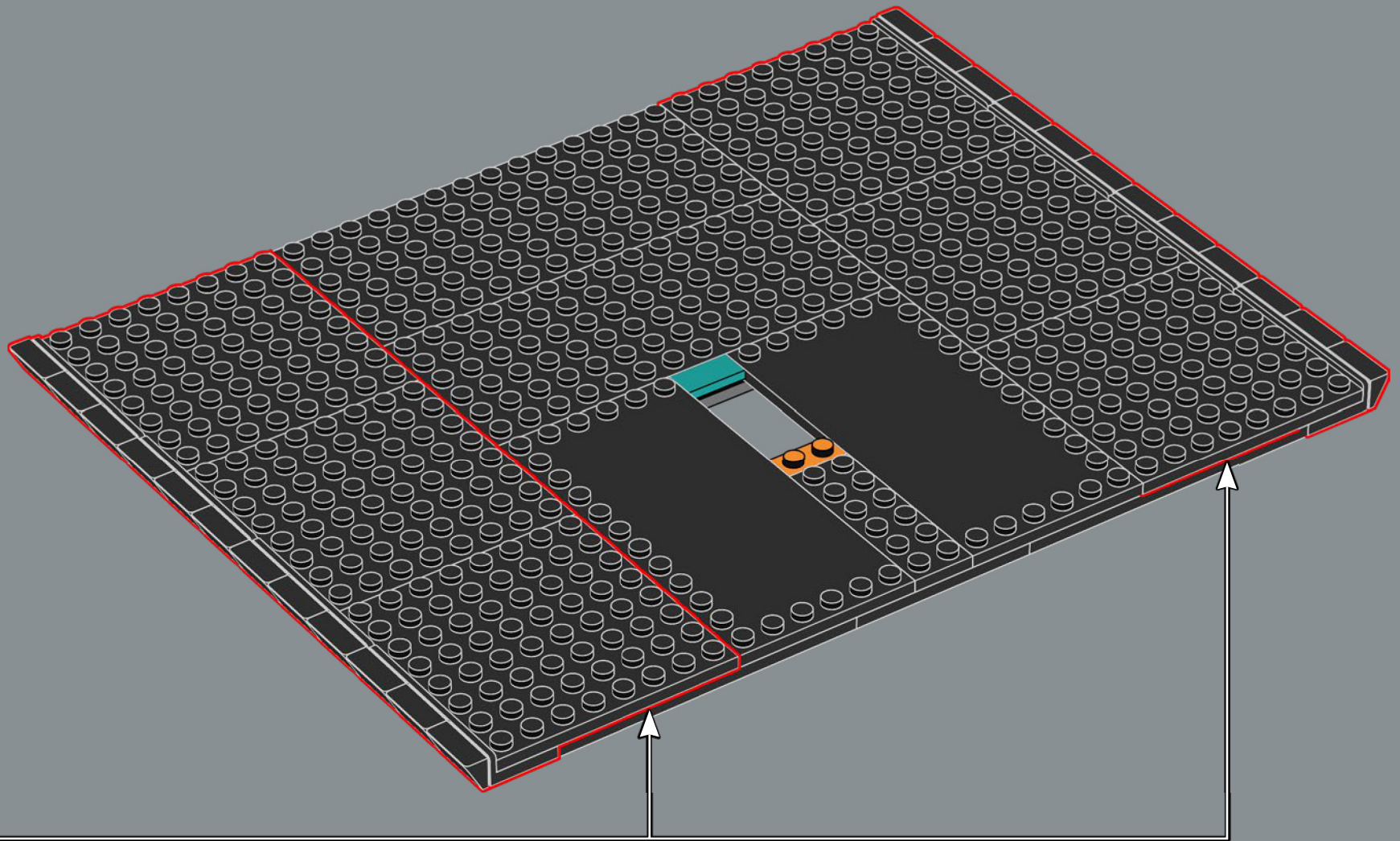

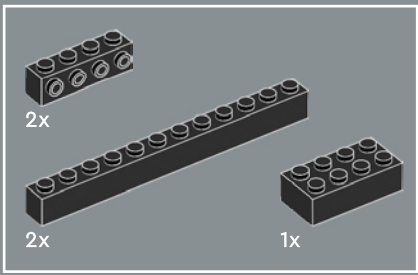

9

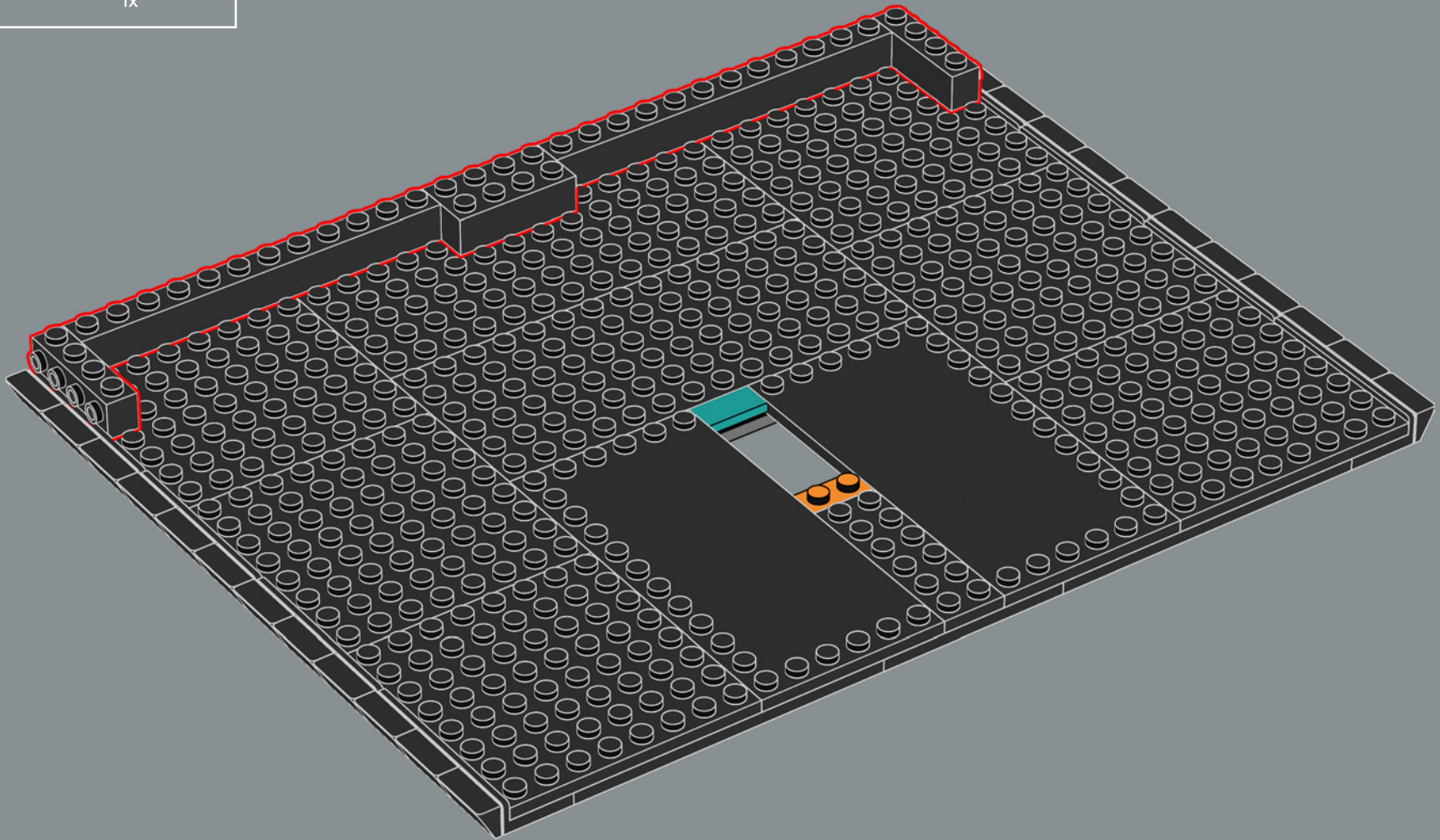

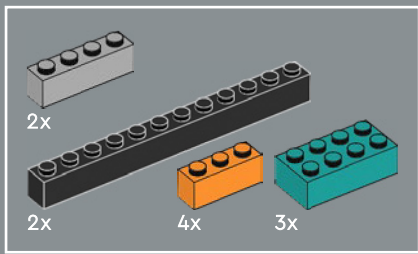

10

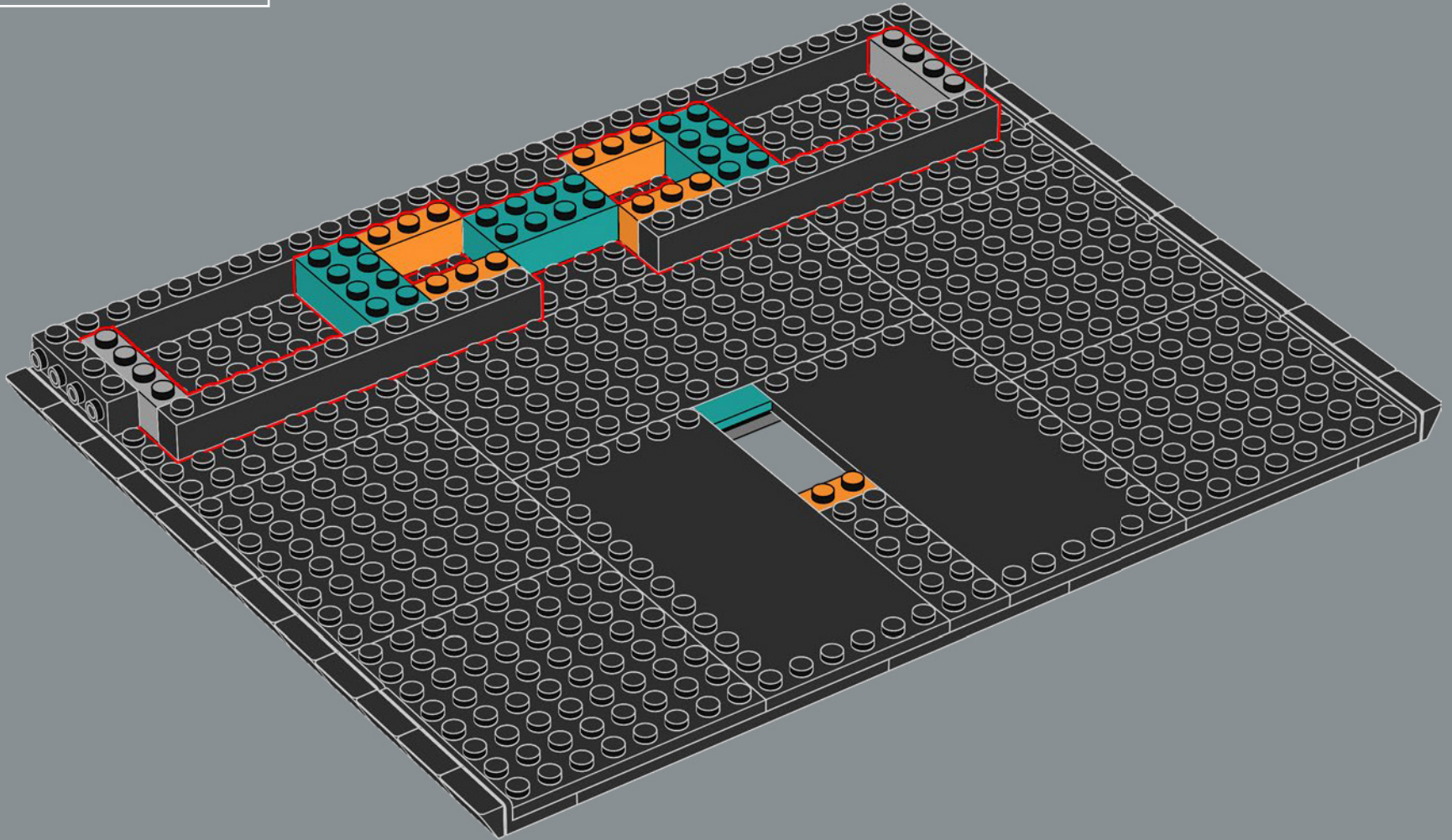

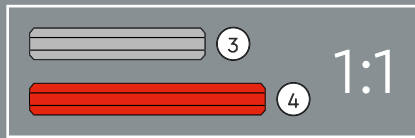
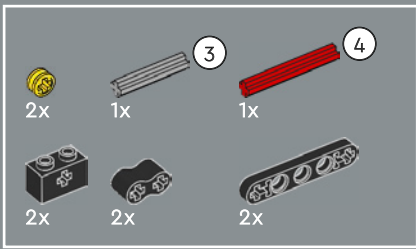

11

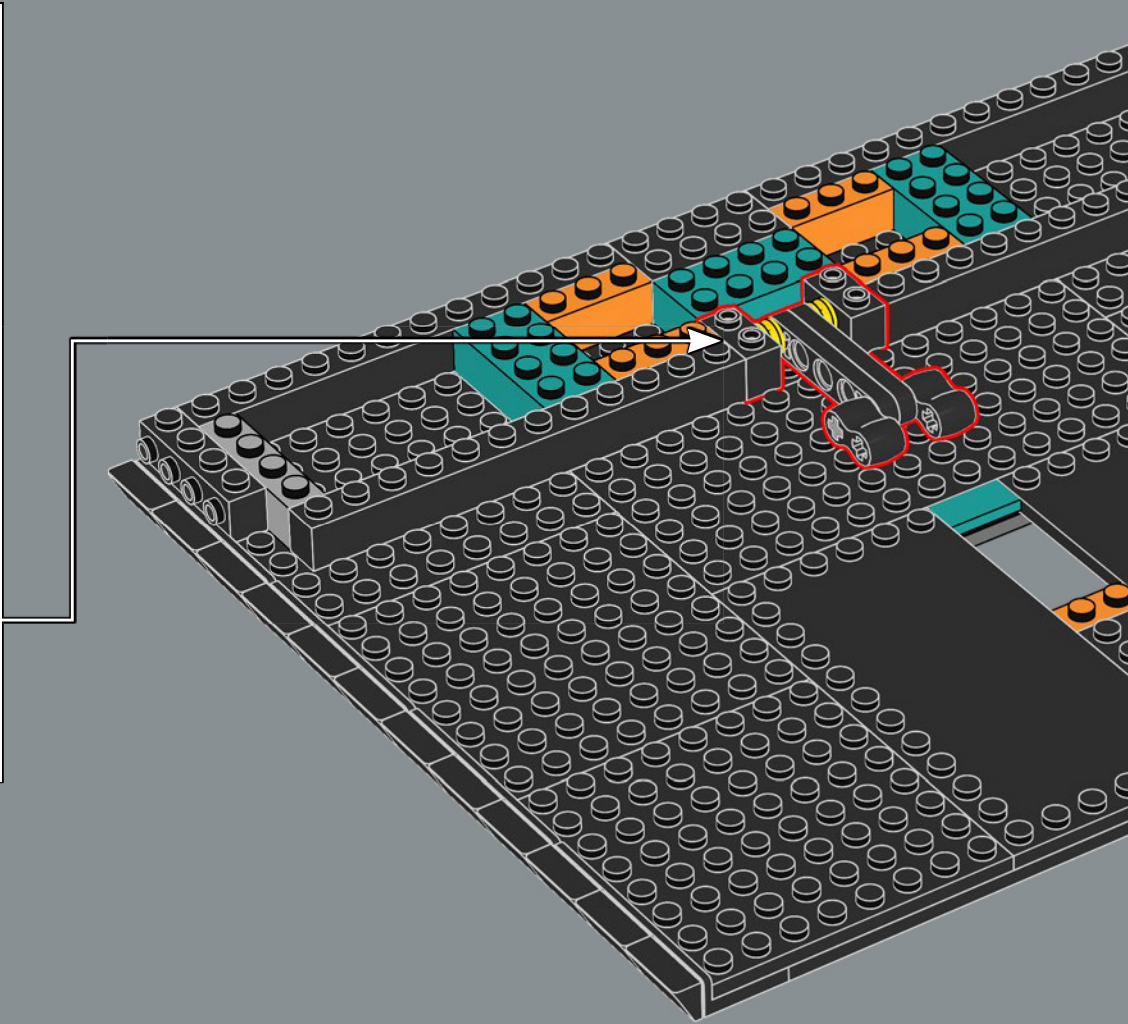
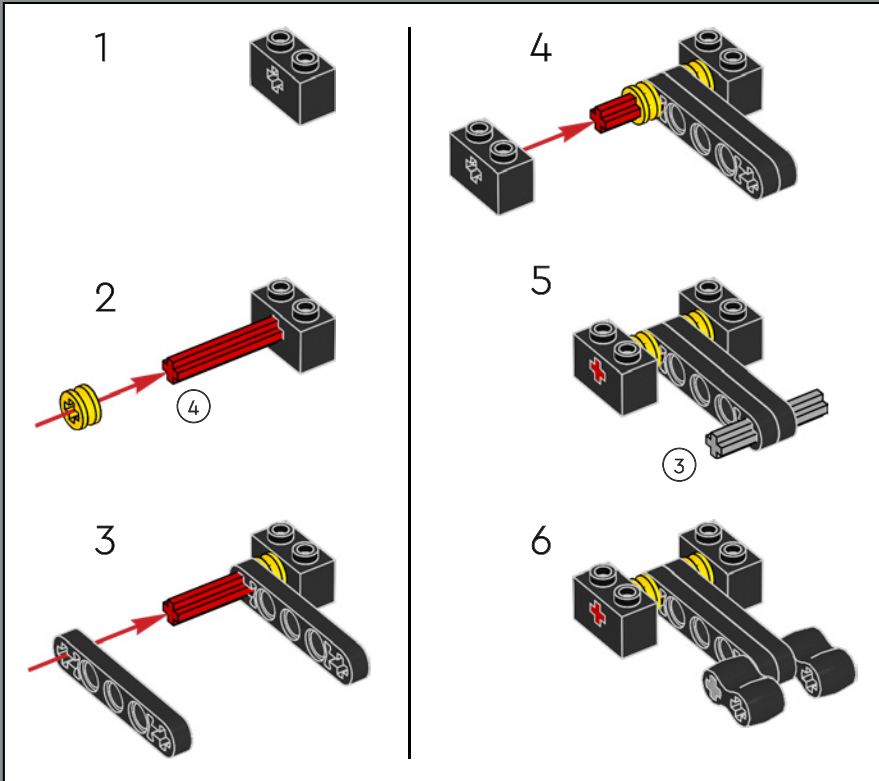

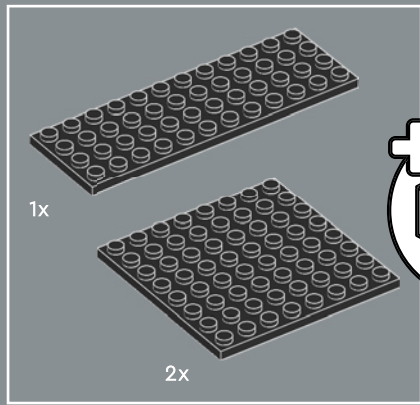

12

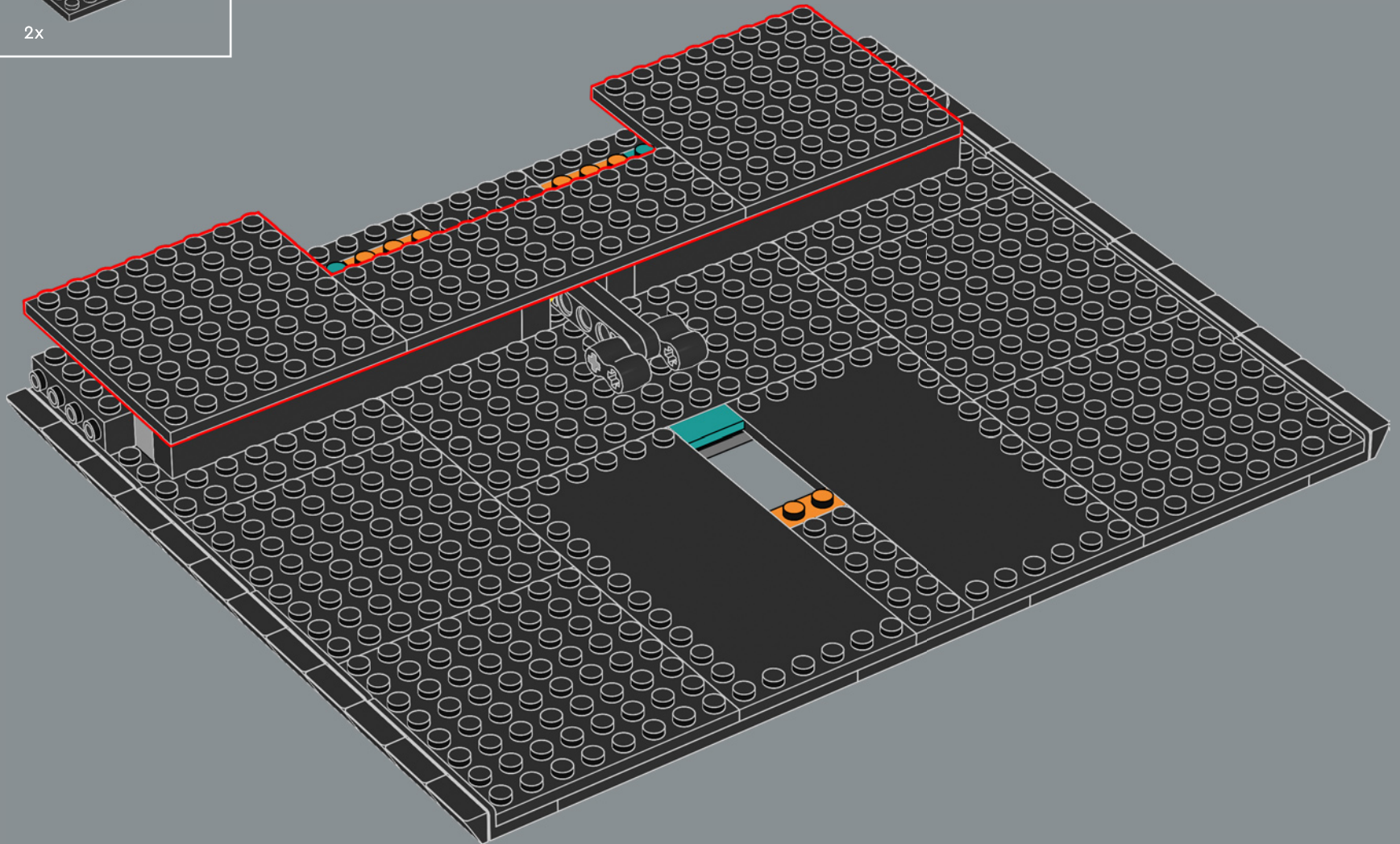

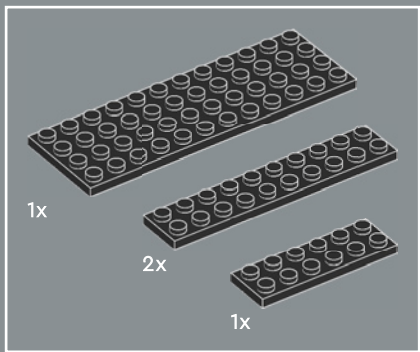

13

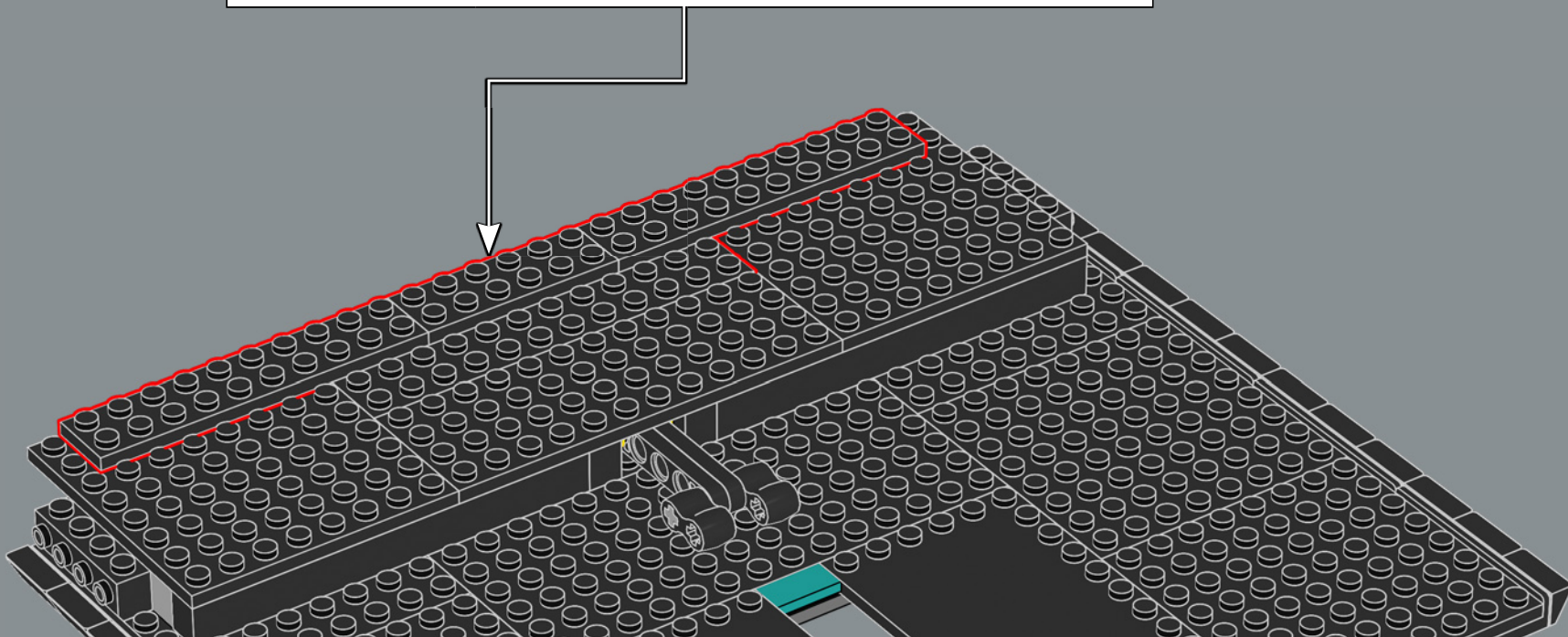
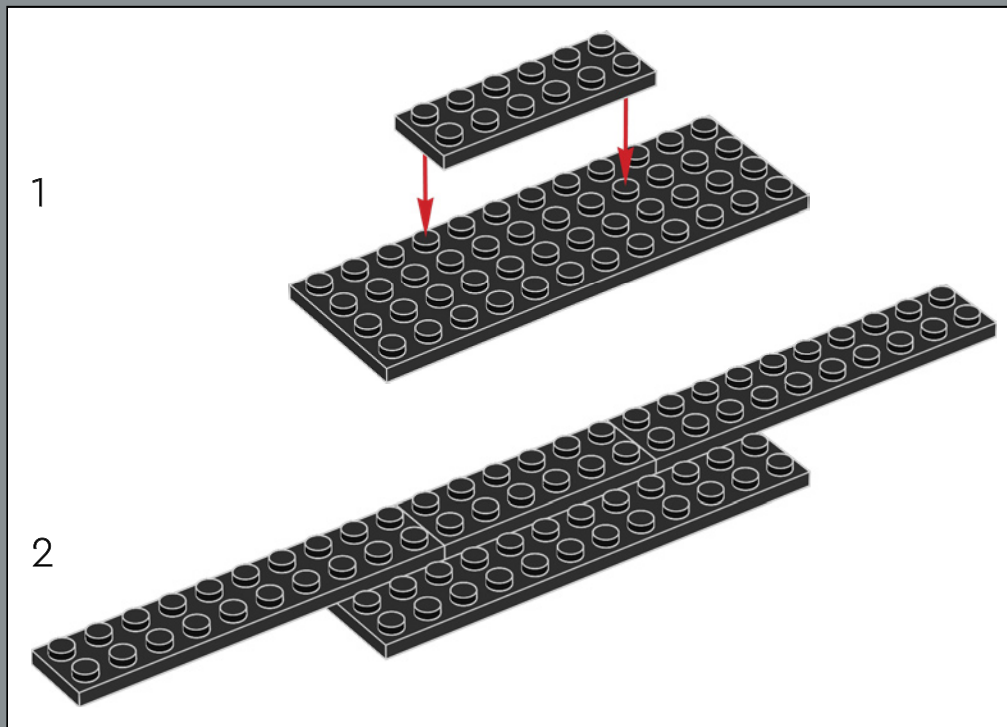

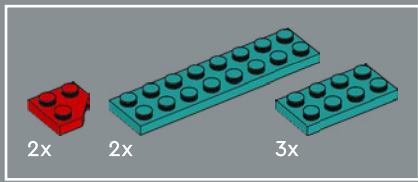

14

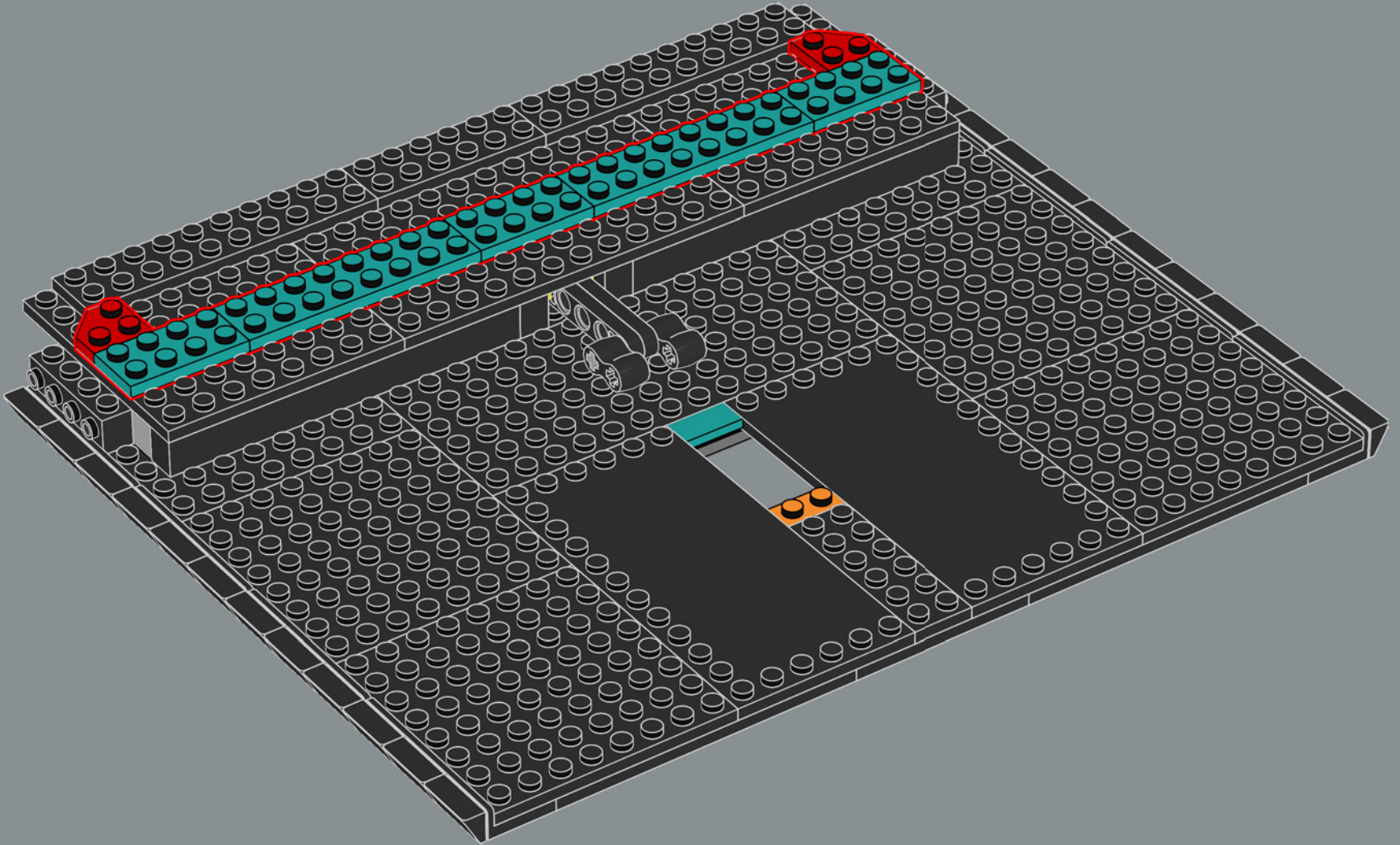

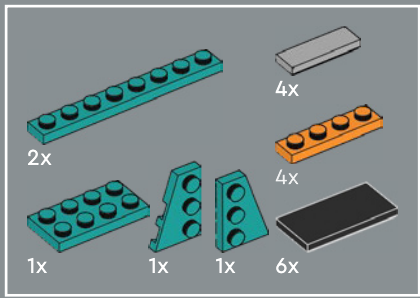

15

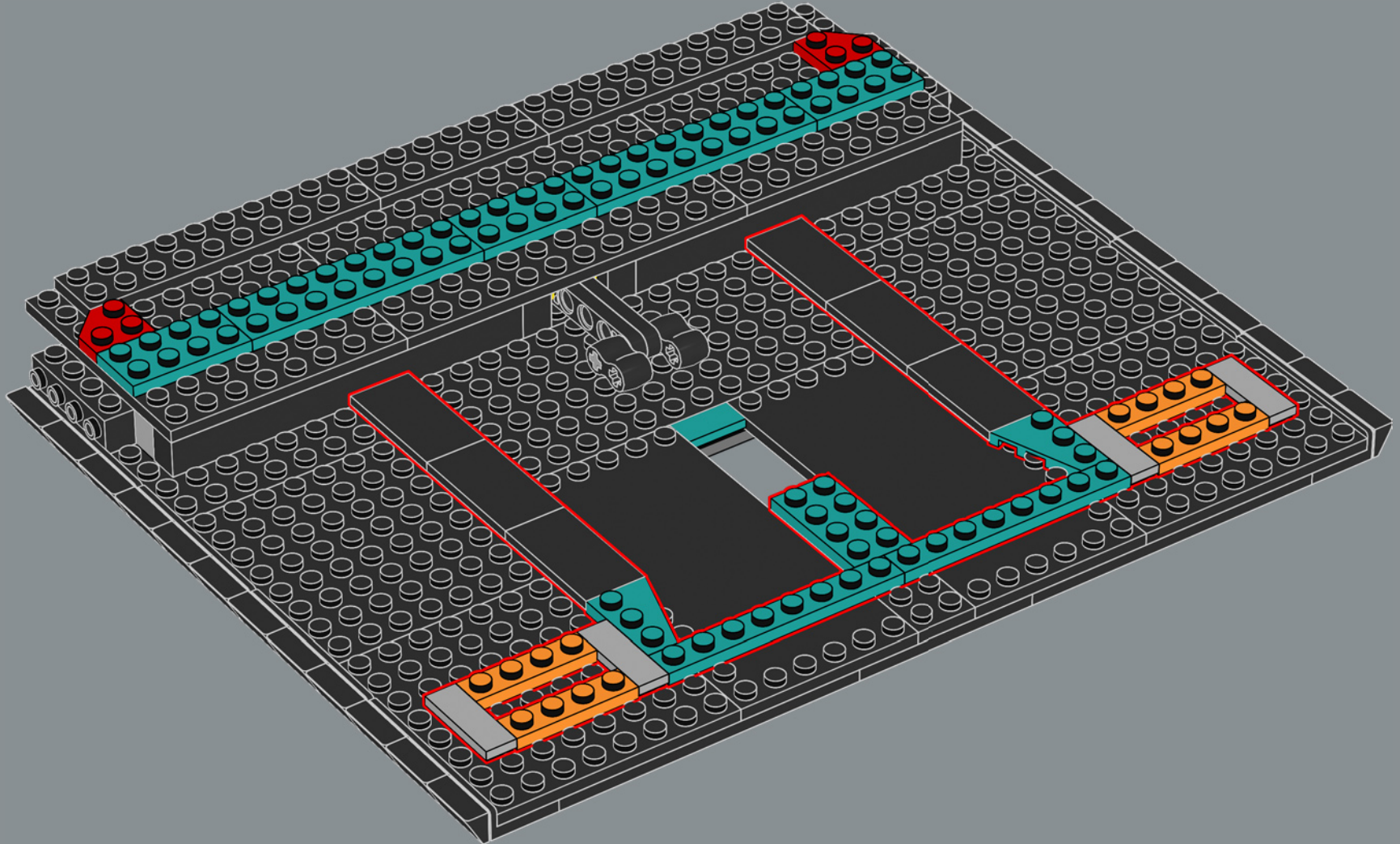

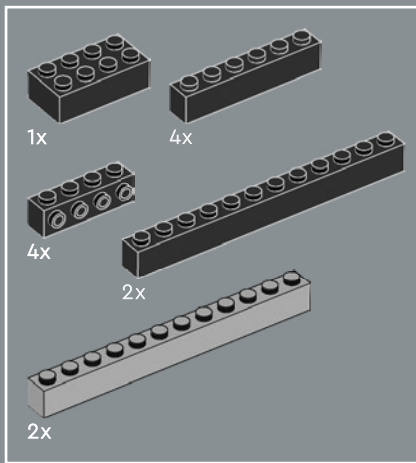

16

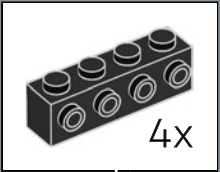
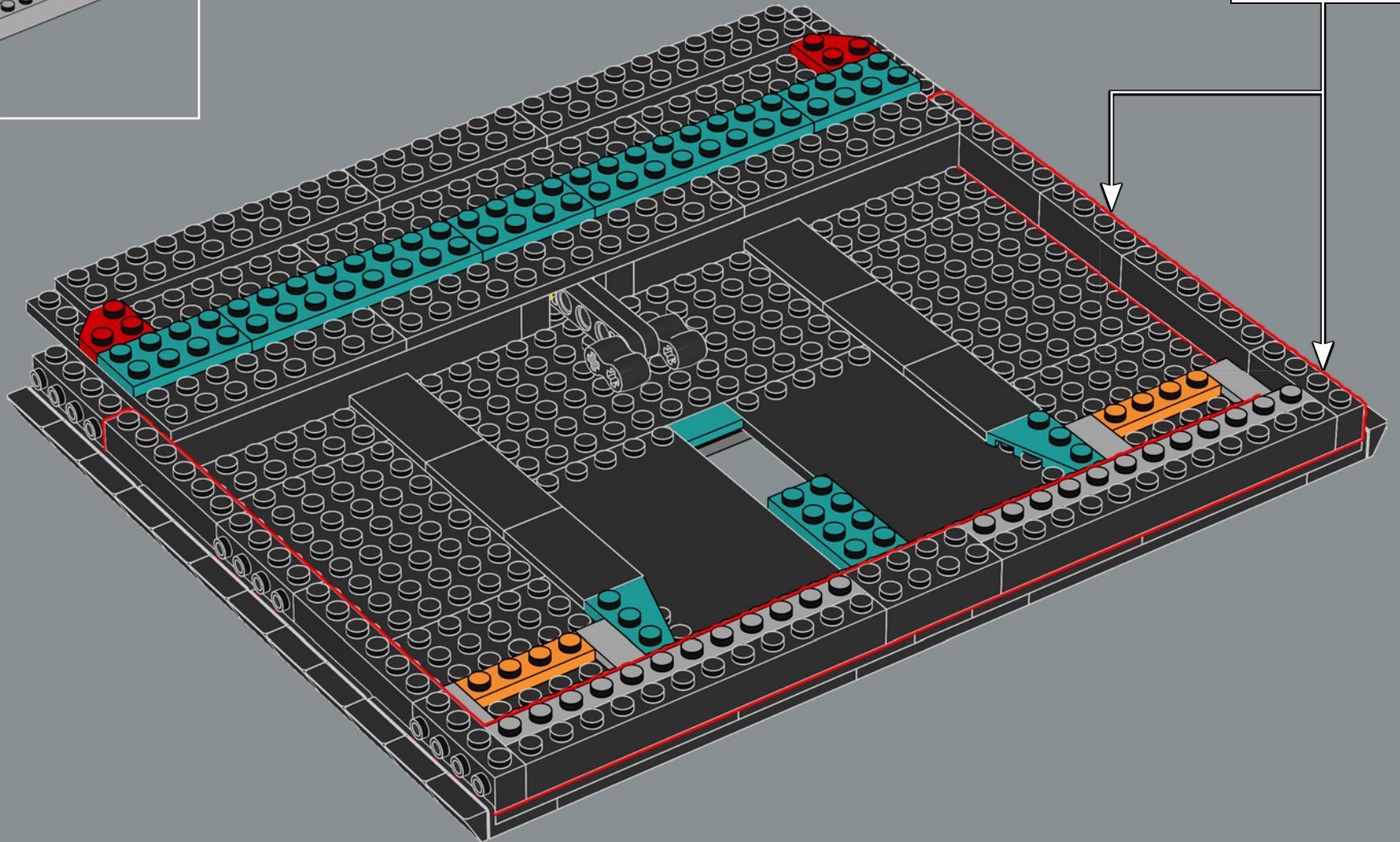

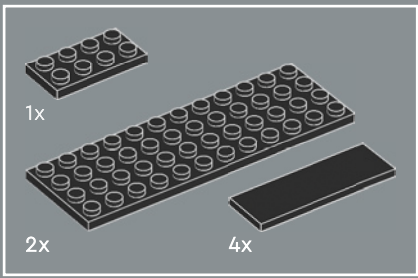

17

1

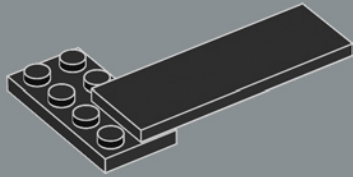

2

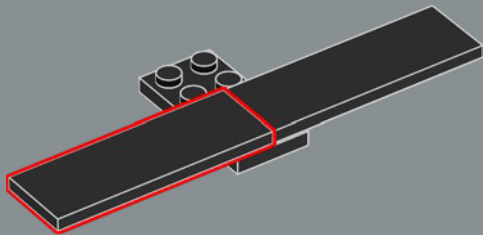

3

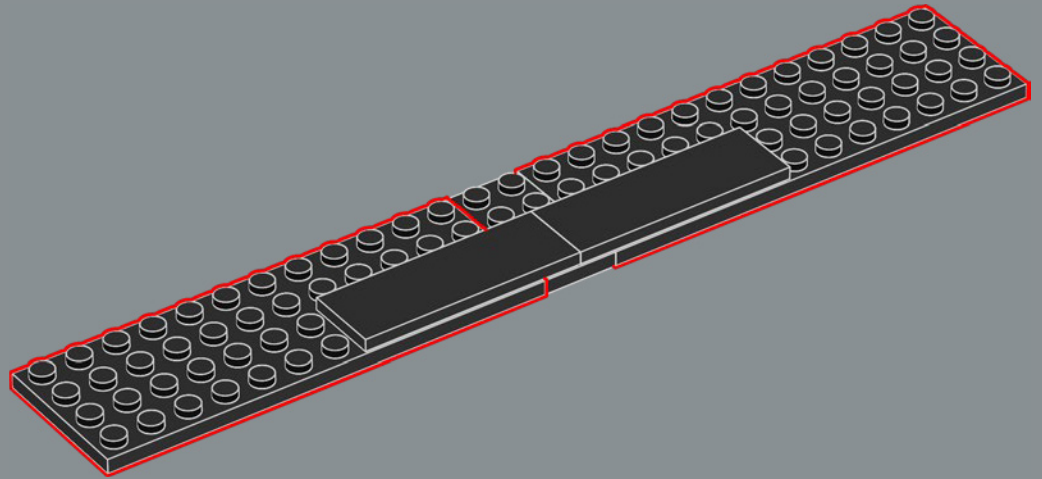

4

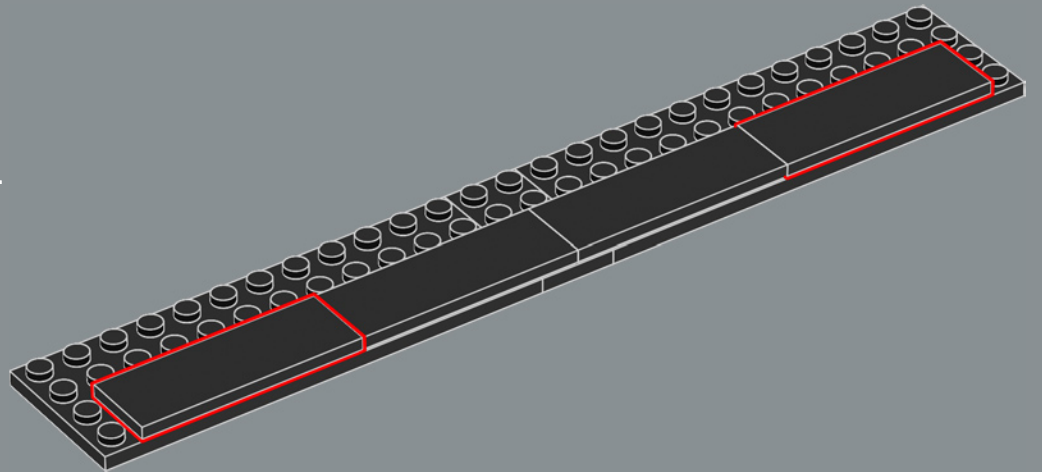

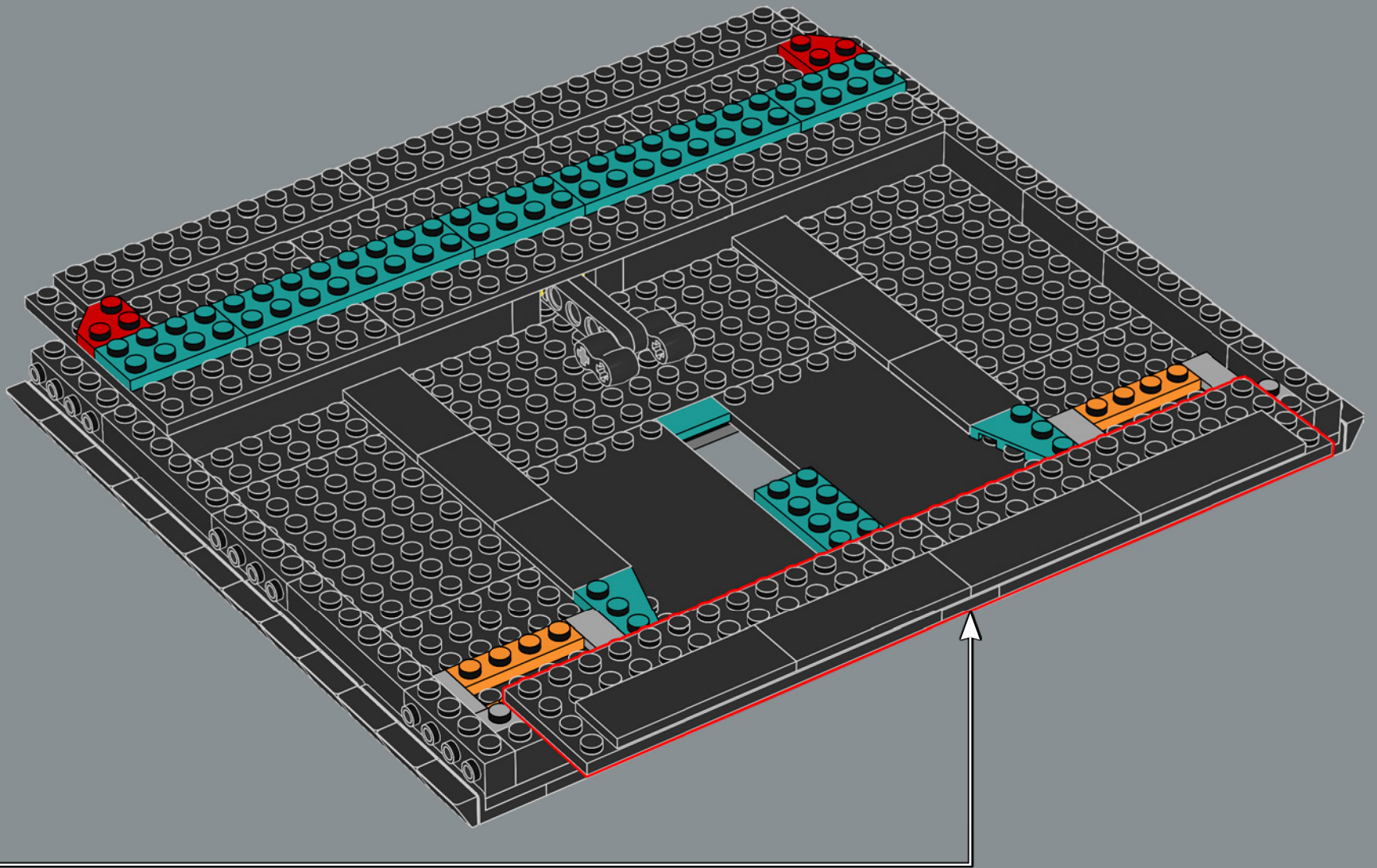

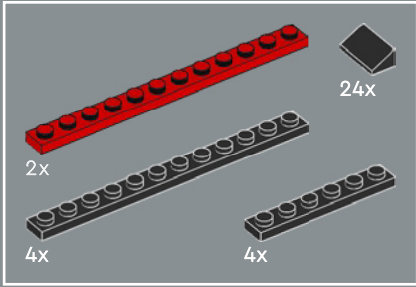
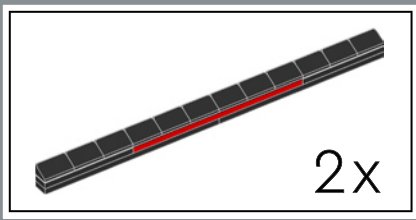

18

1

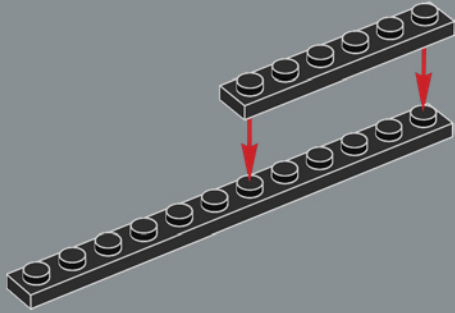

2

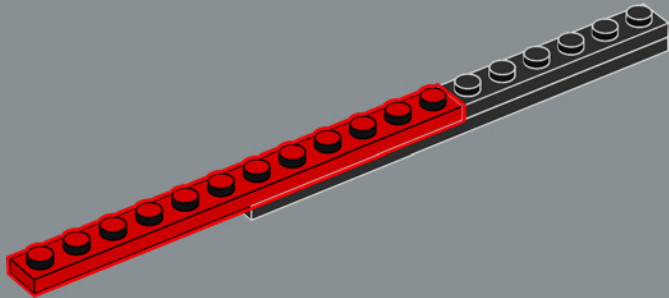

3

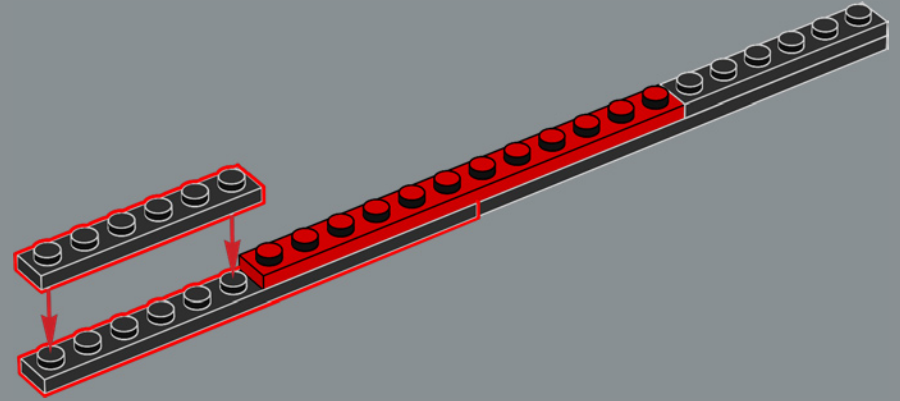

4

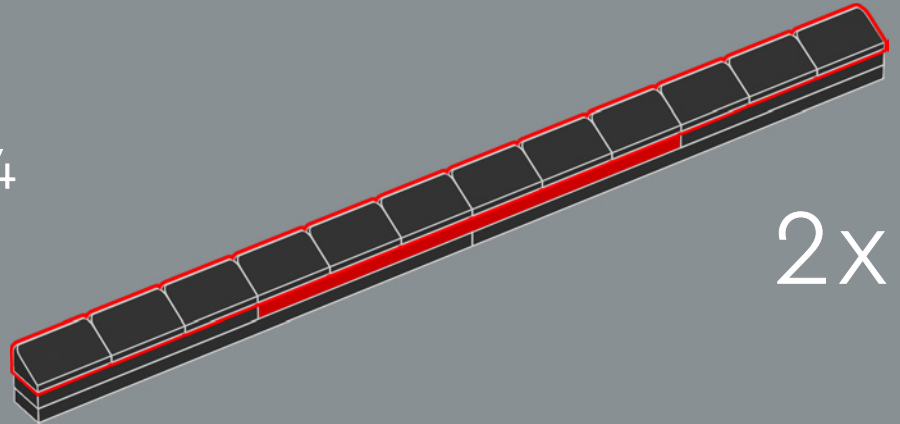

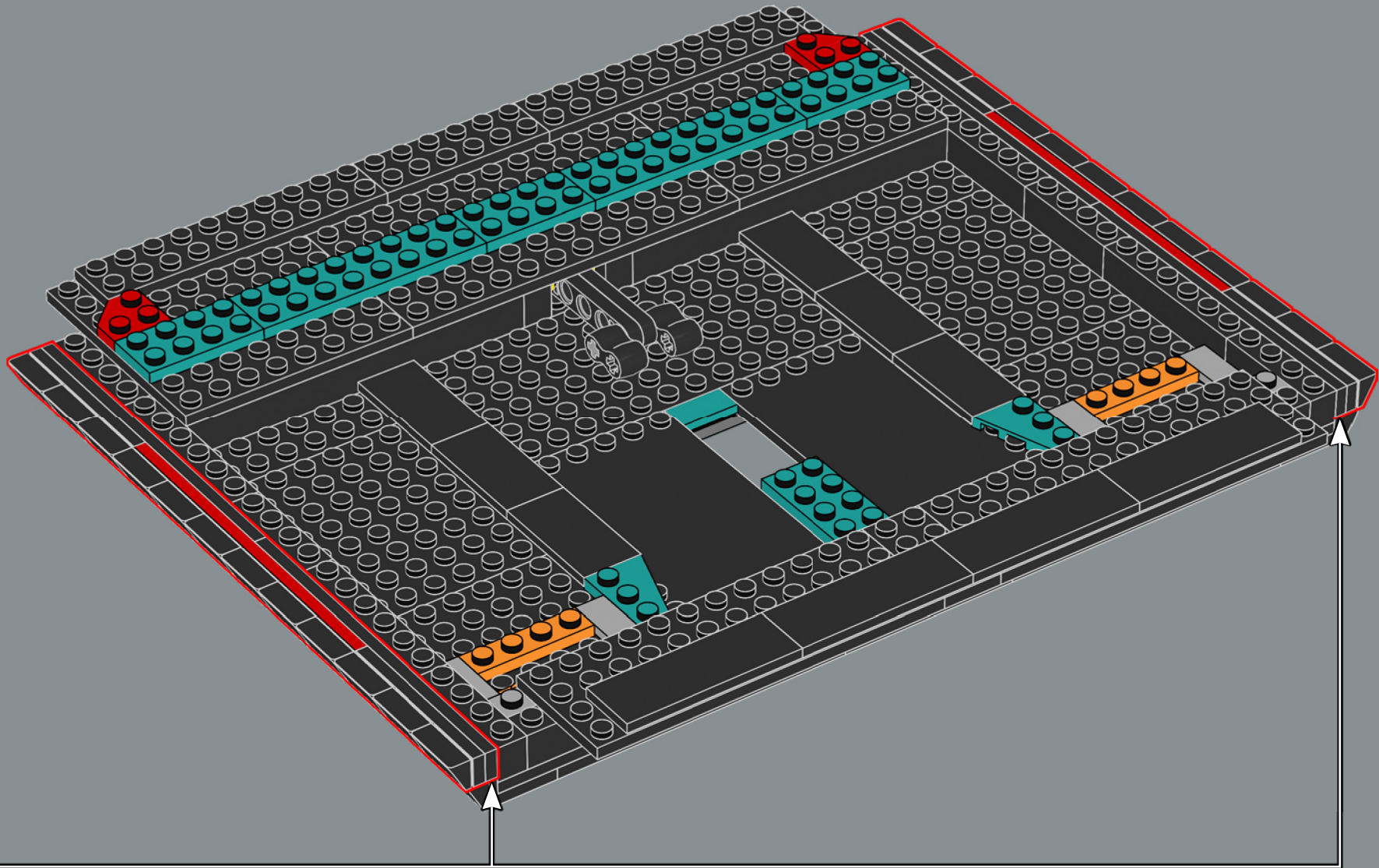

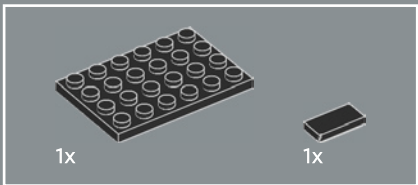
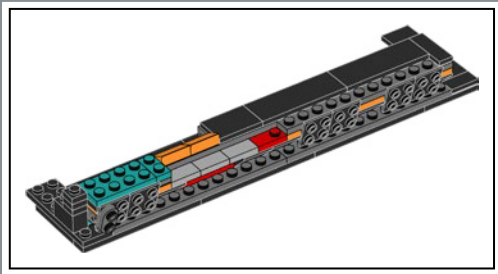

19

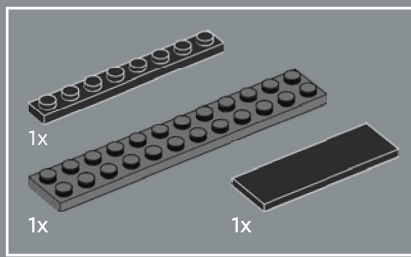
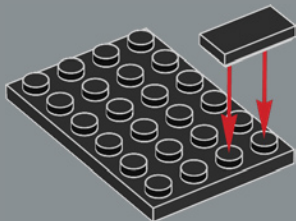

20

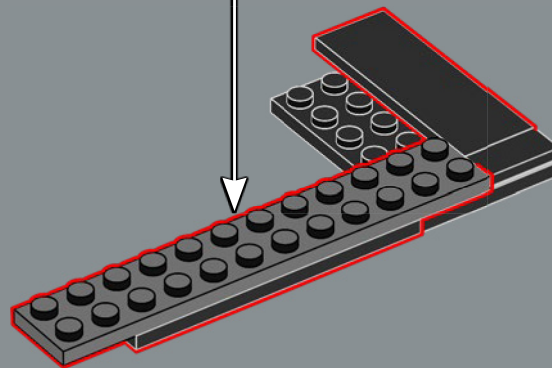
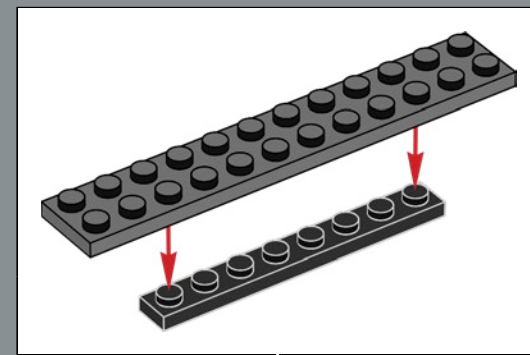

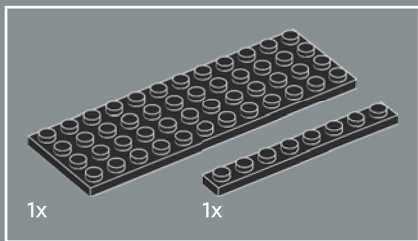

21

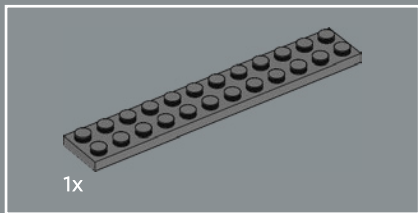
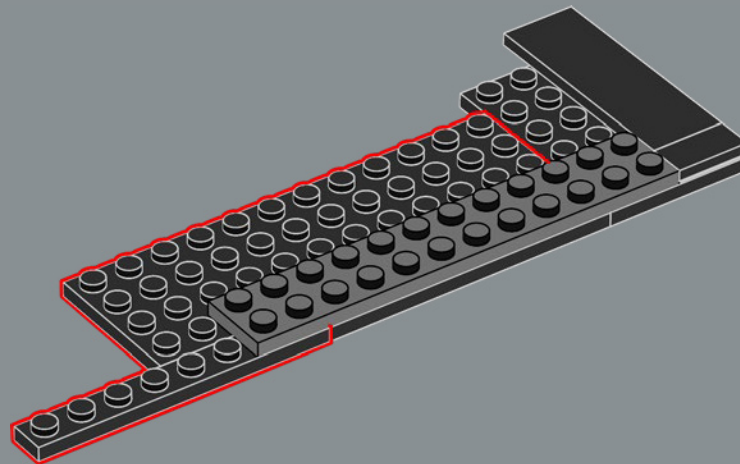

22

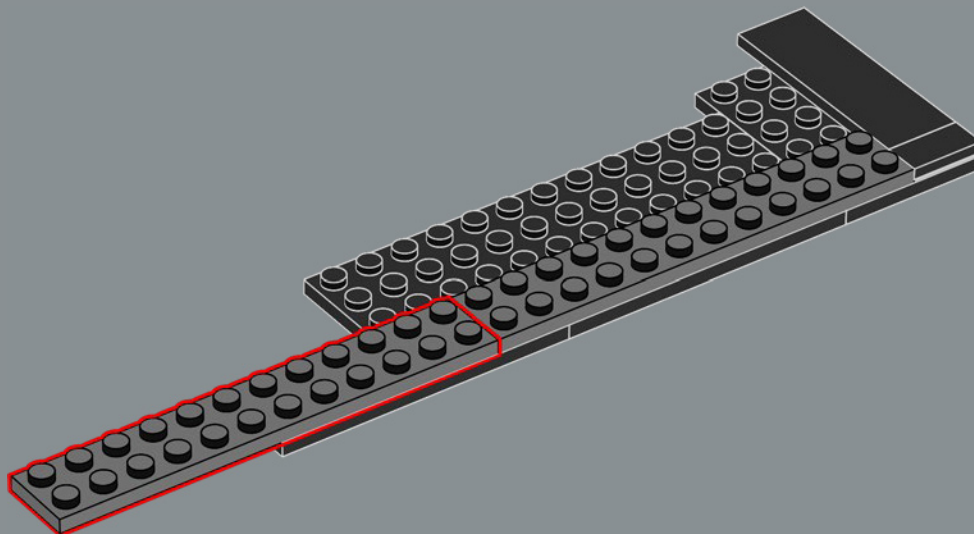

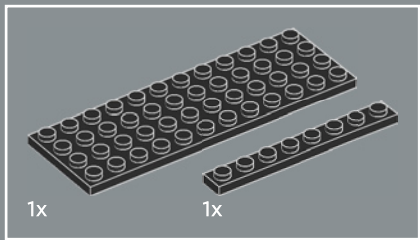

23

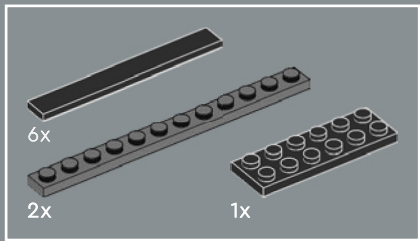
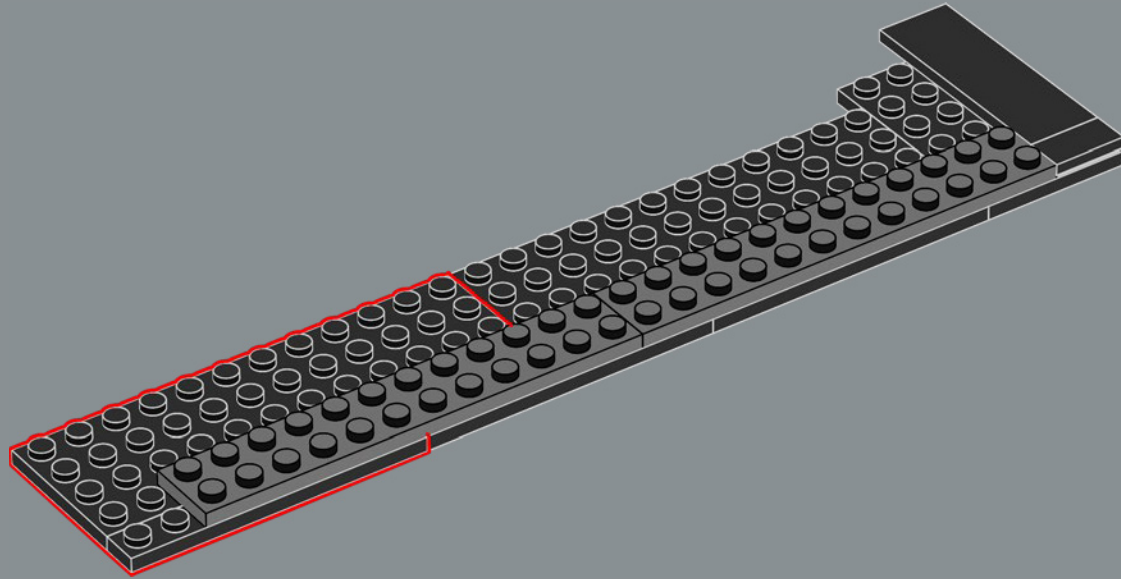

24

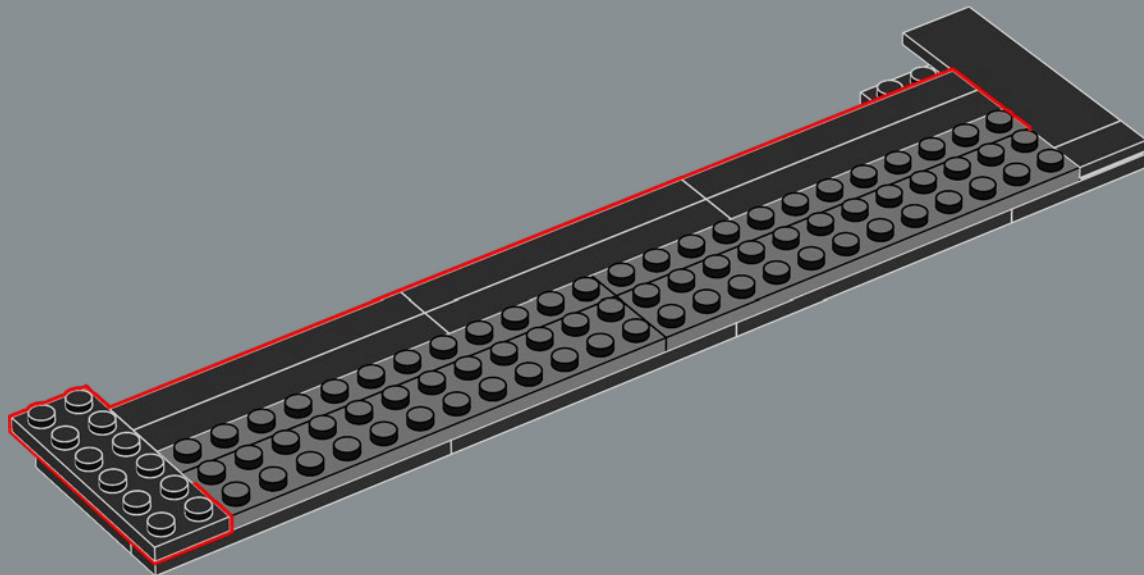

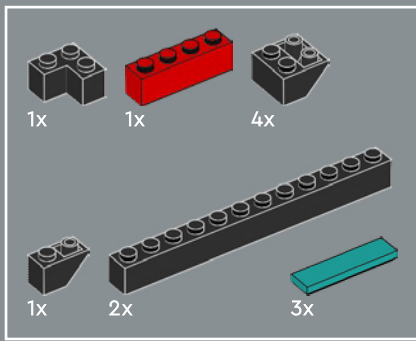

25

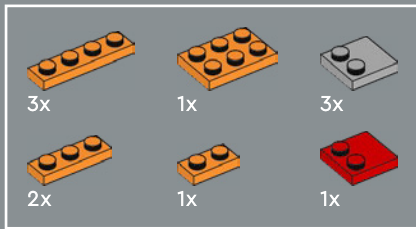
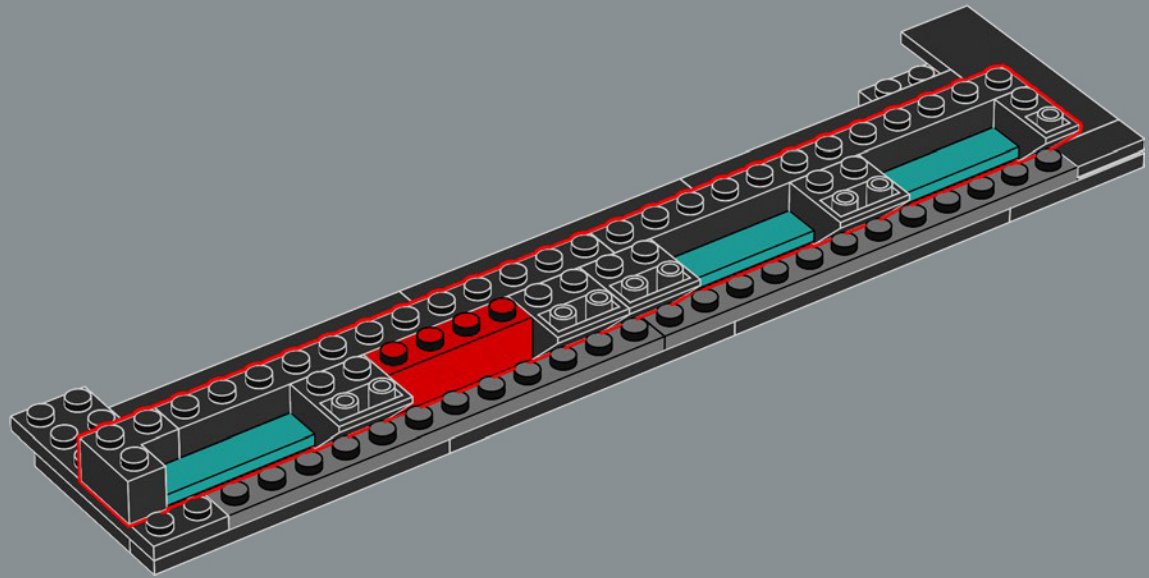

26

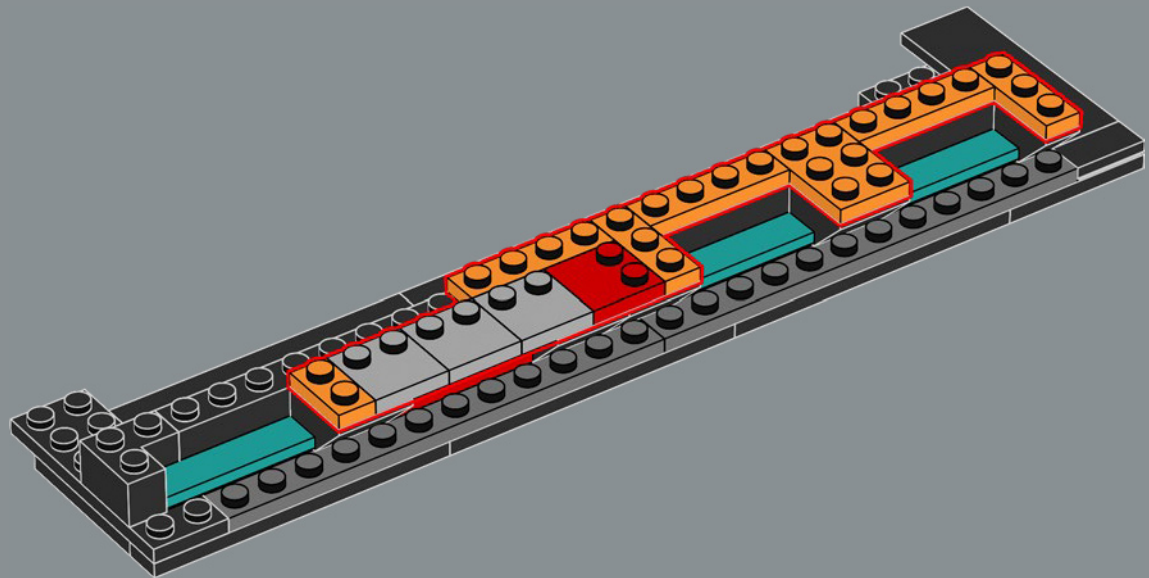

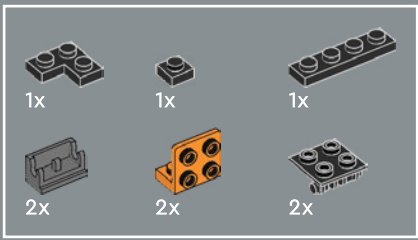

27

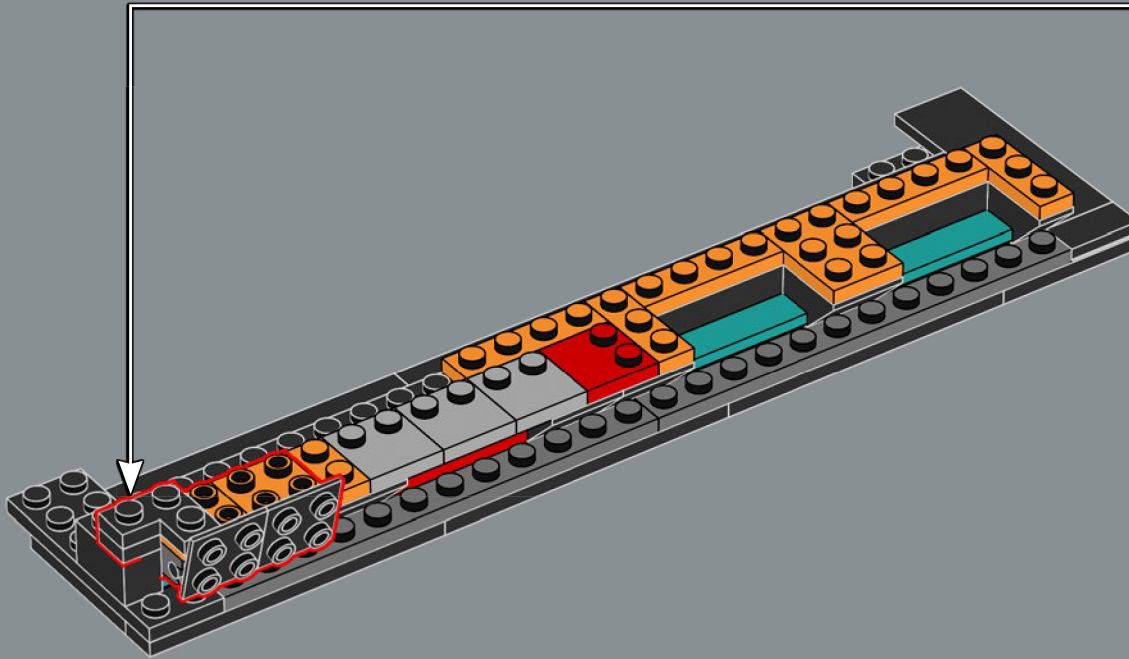
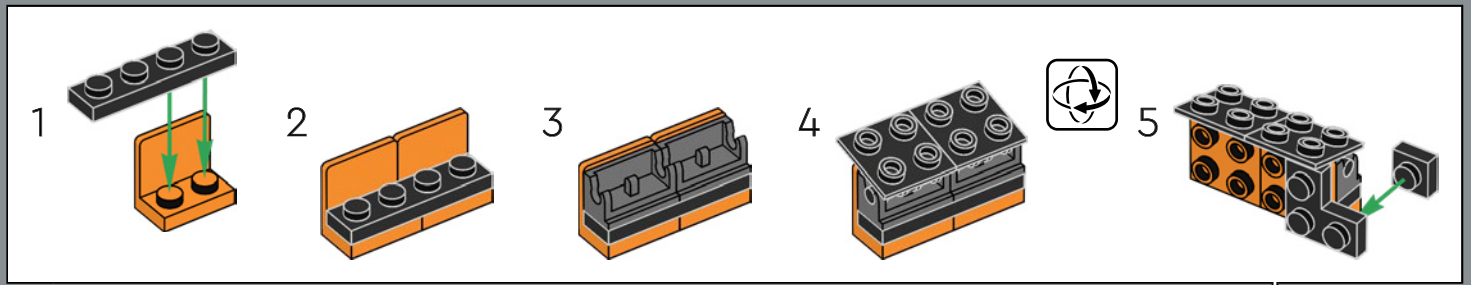

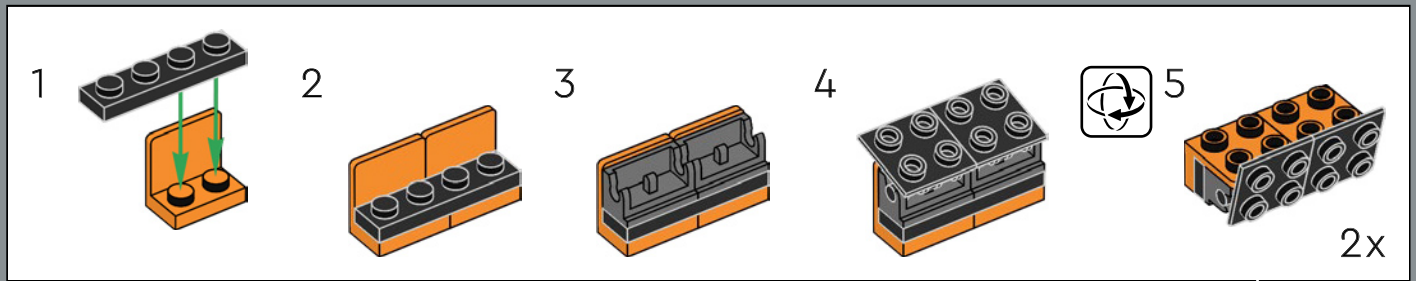
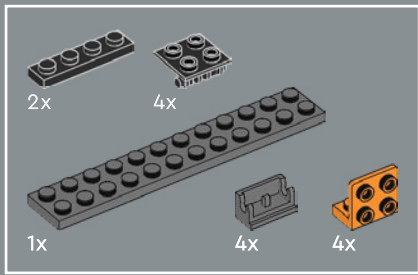

28

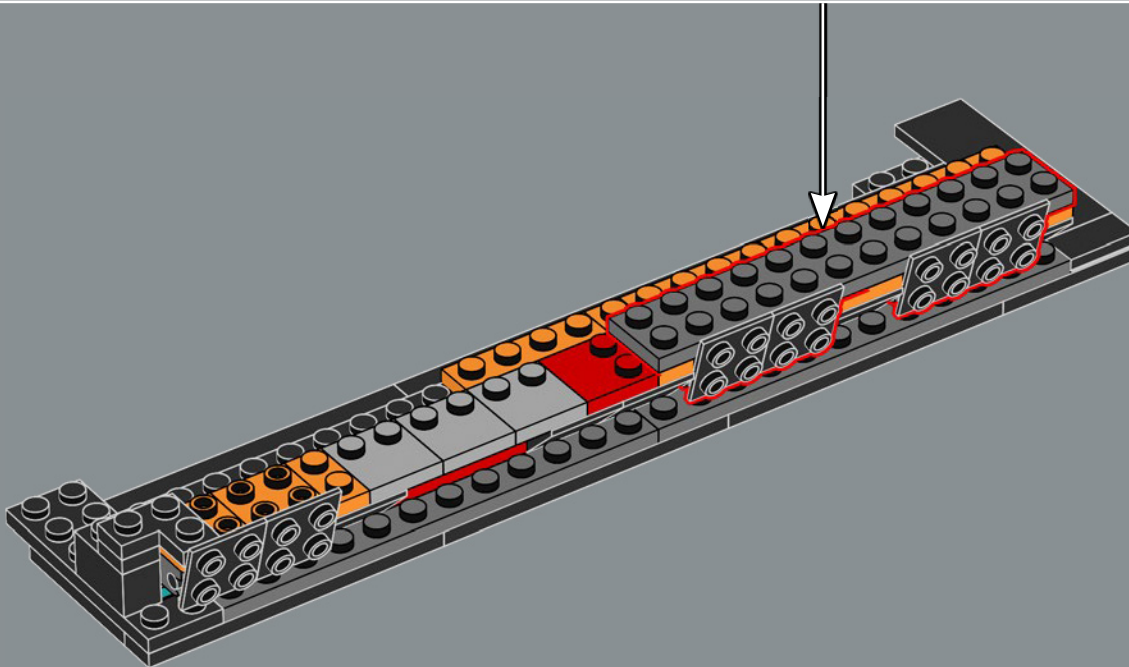
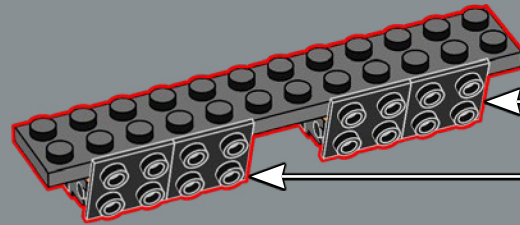

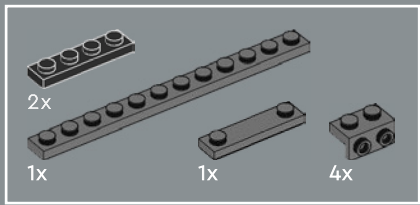

29

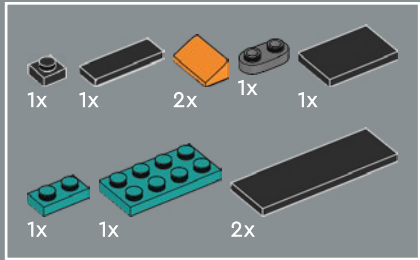
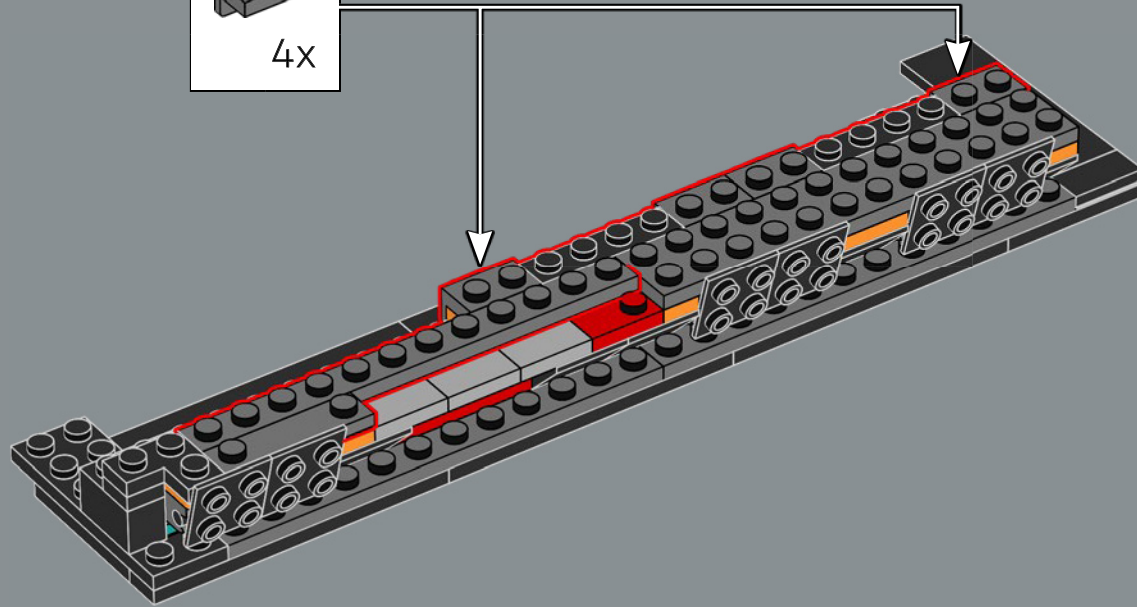
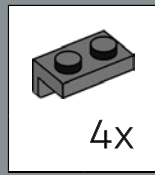

30

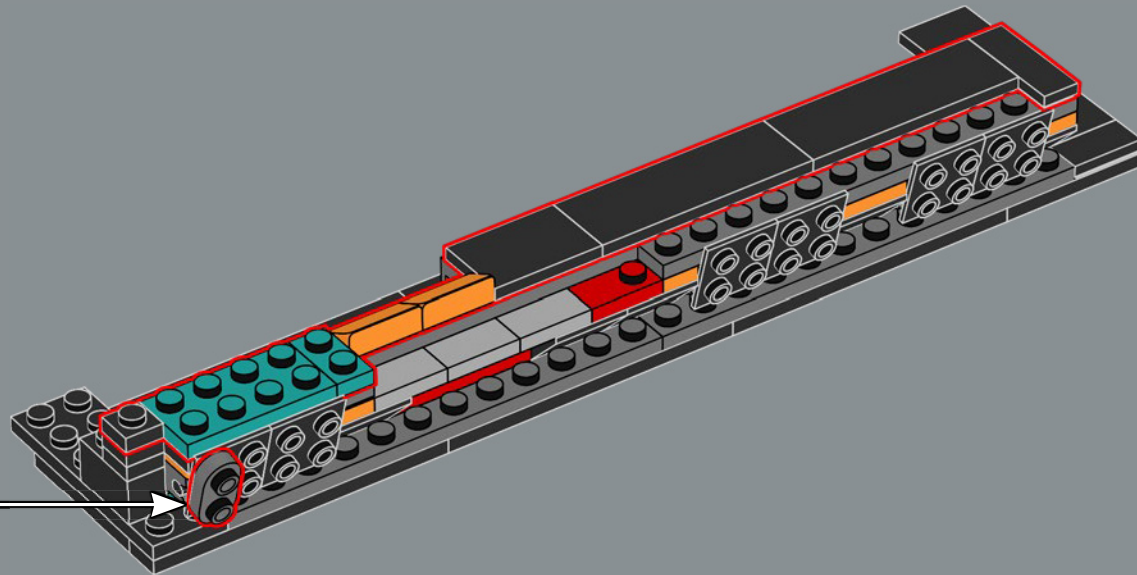

31

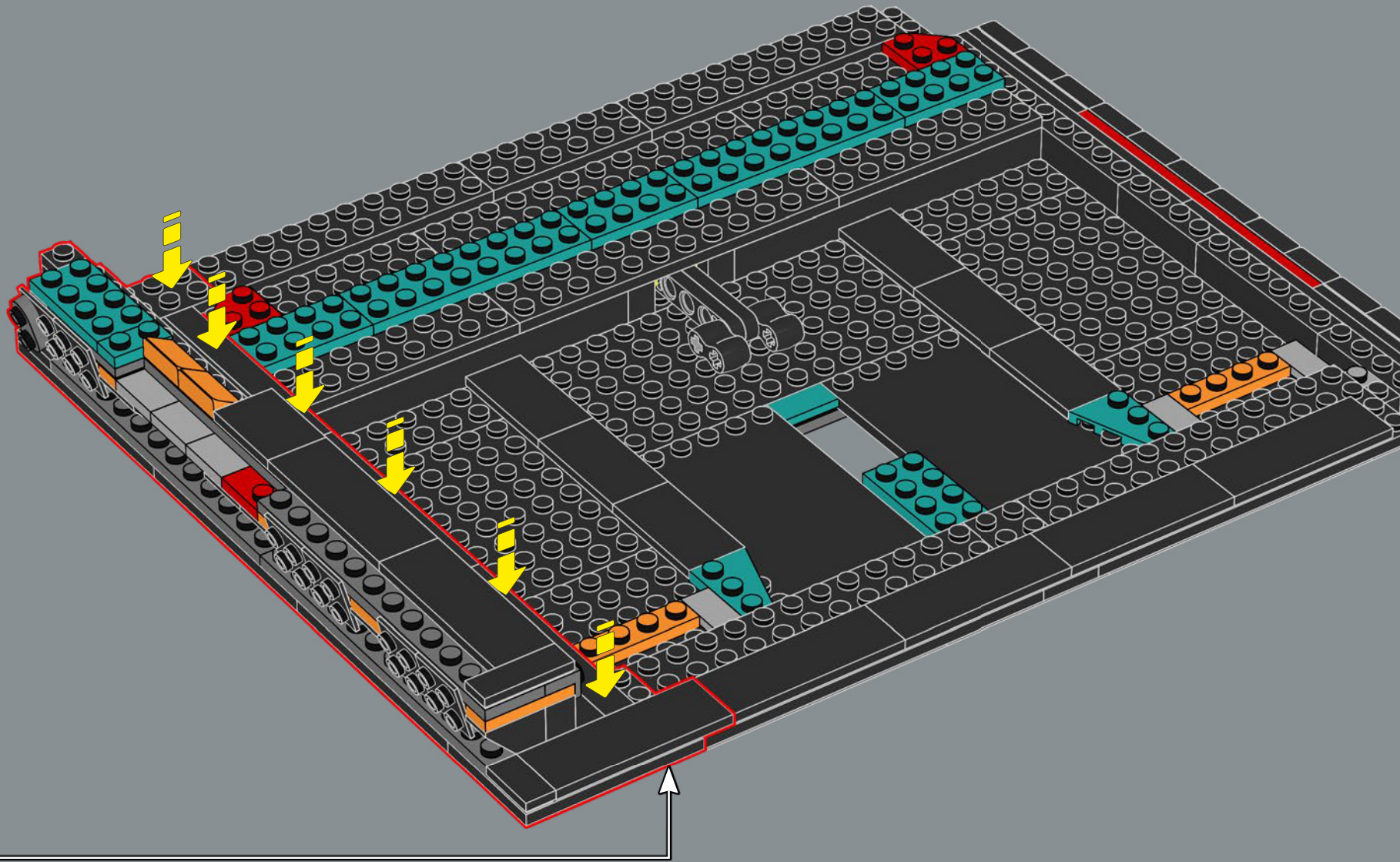

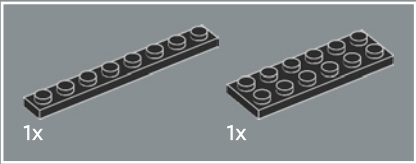
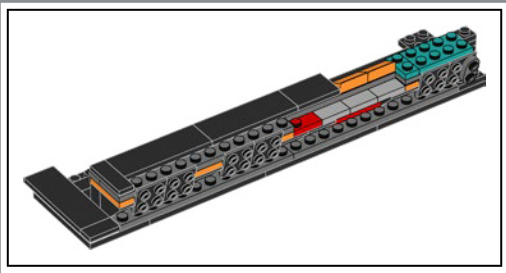

32

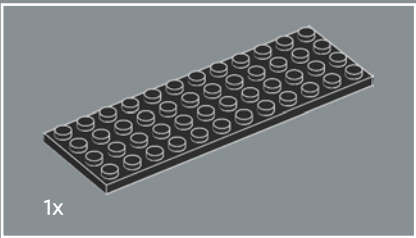
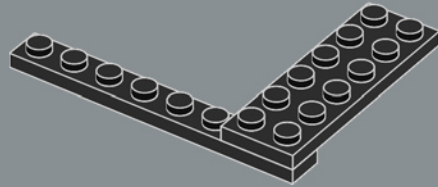

33

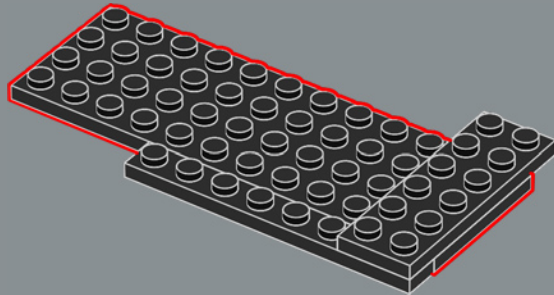

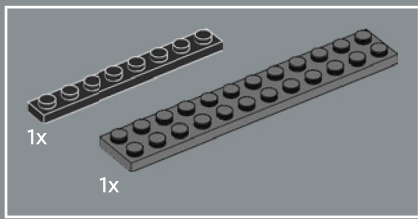

34

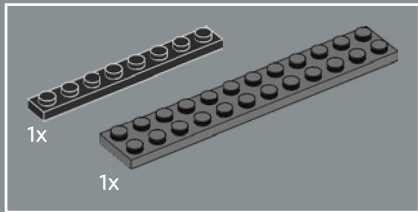
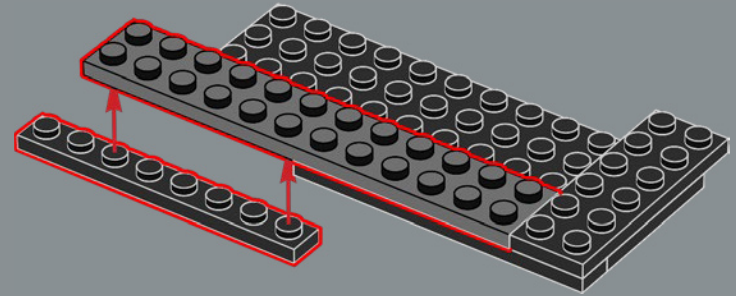

35

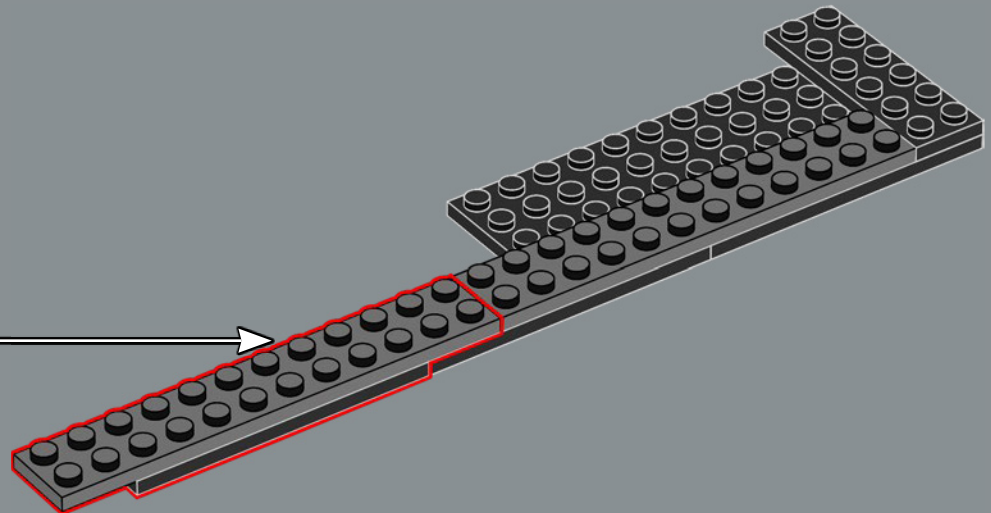
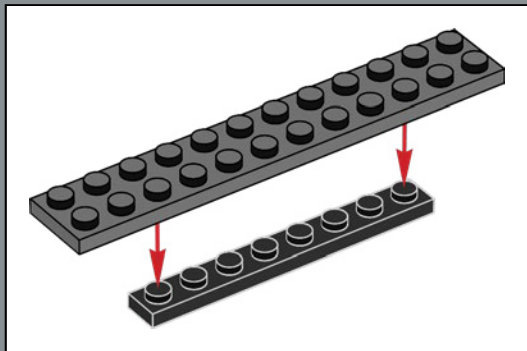

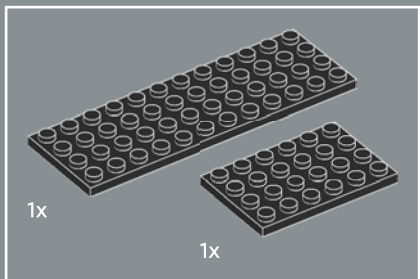

36

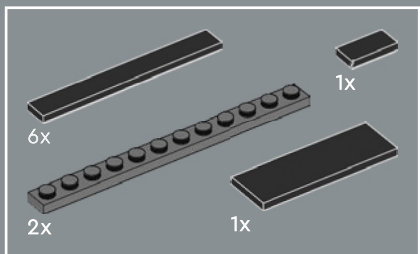
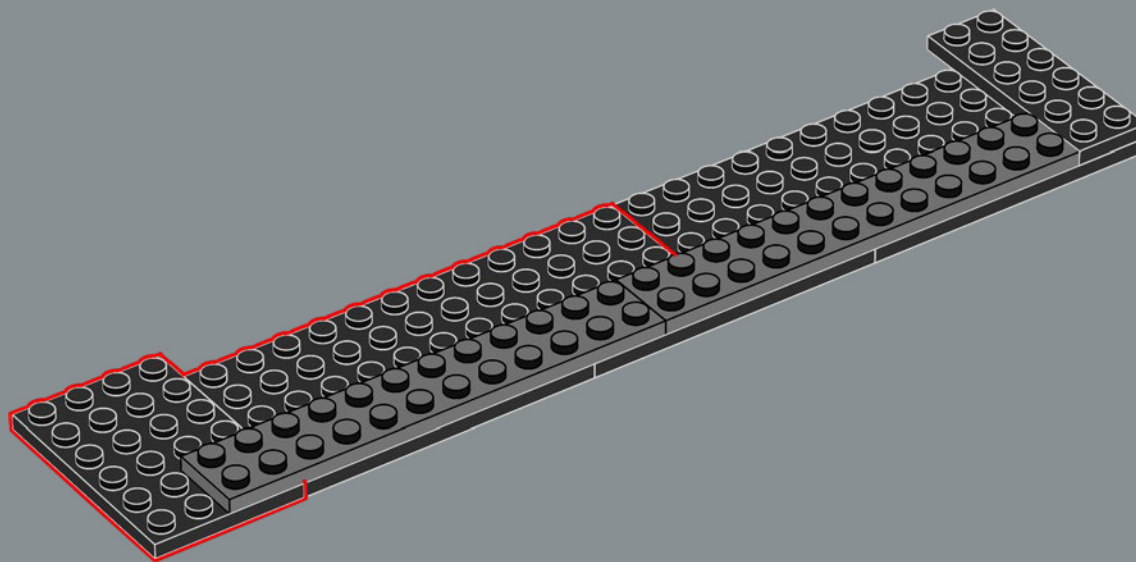

37

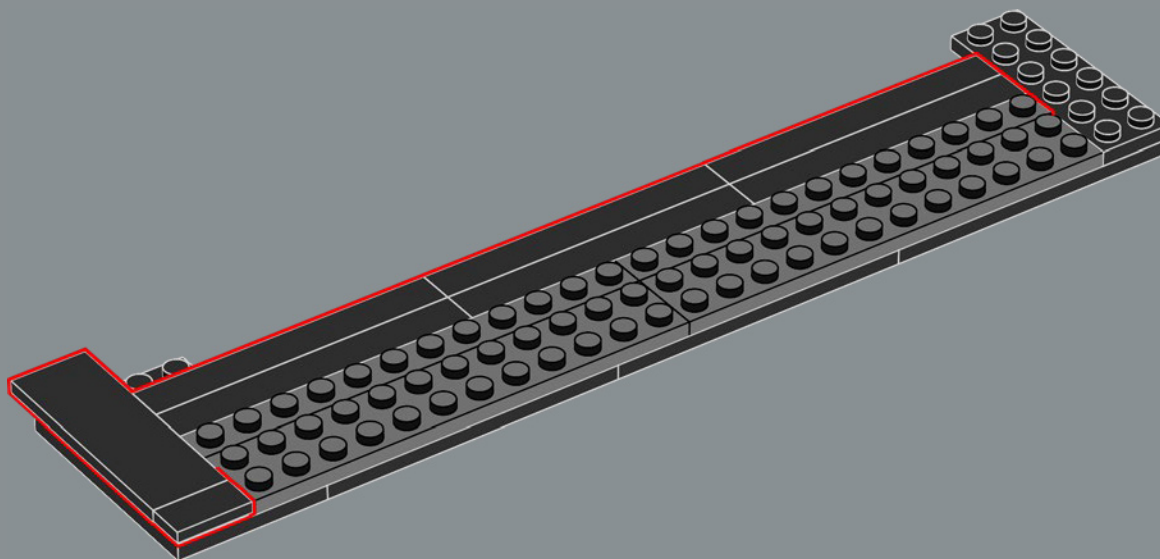

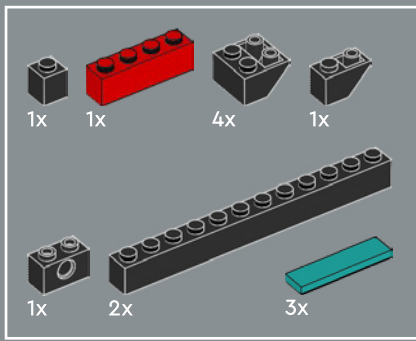

38

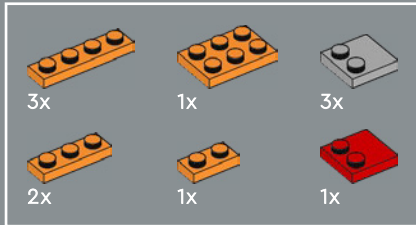
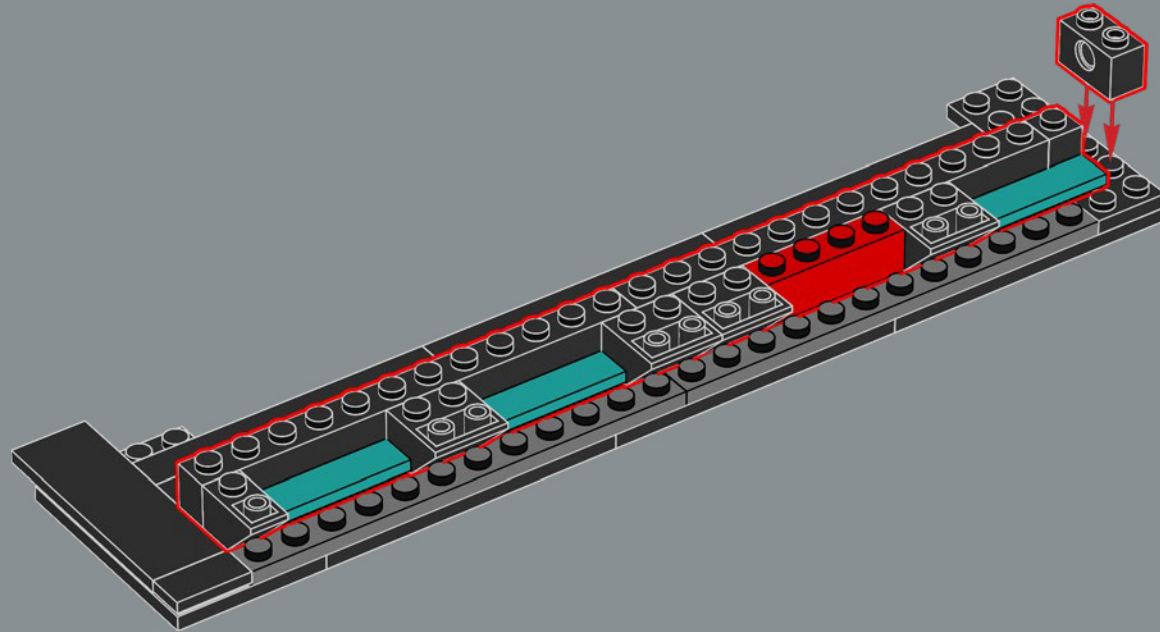

39

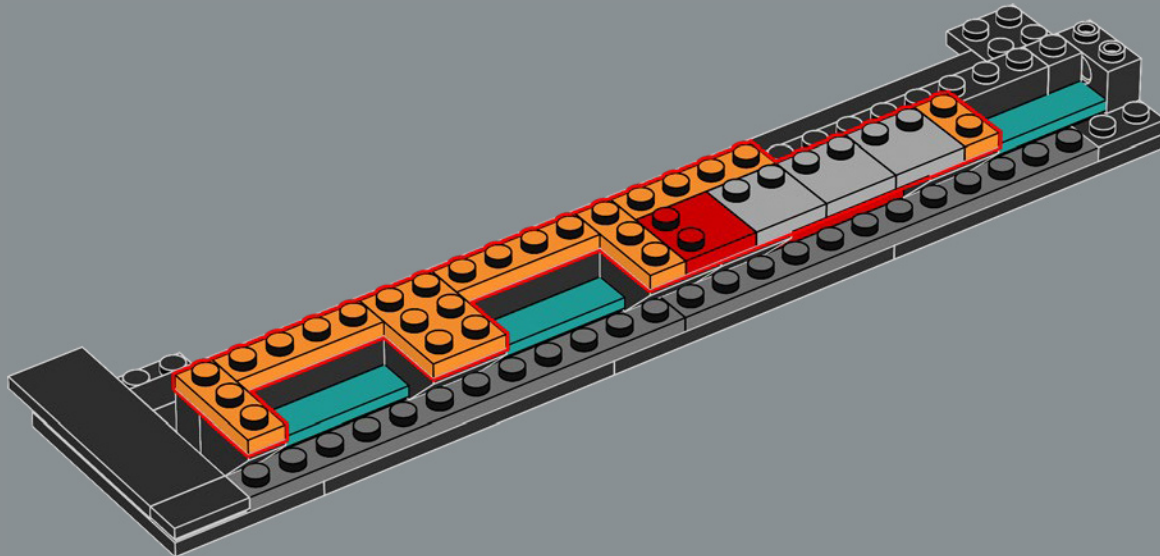

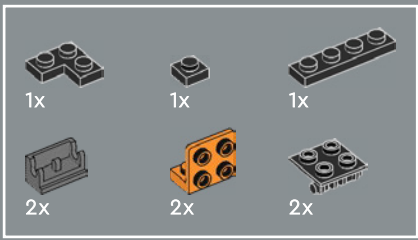

40

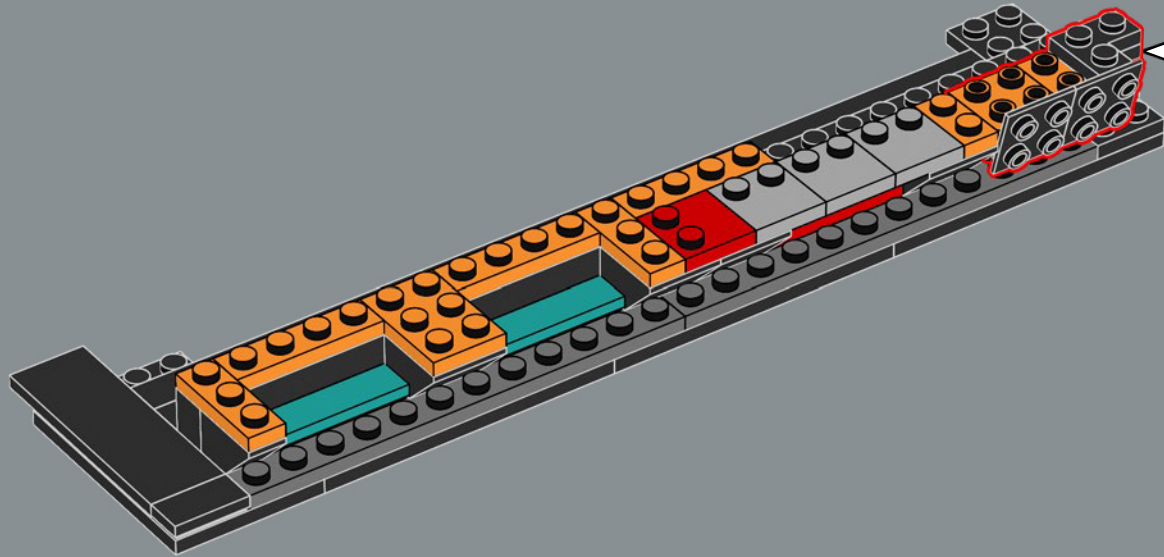
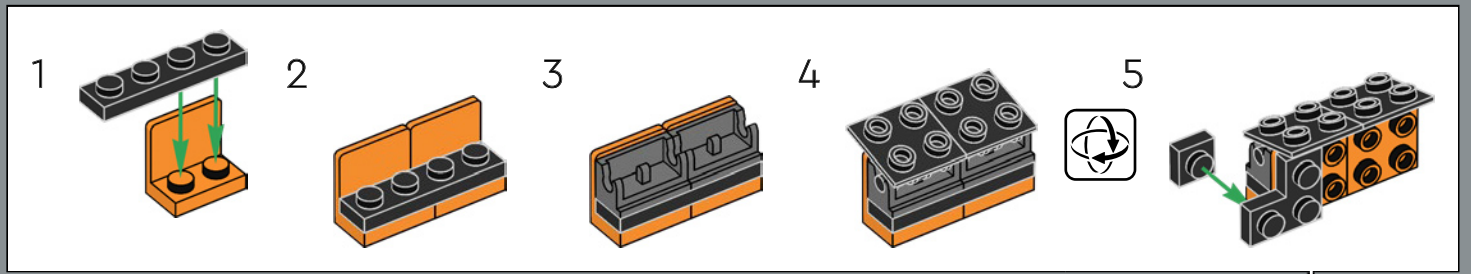

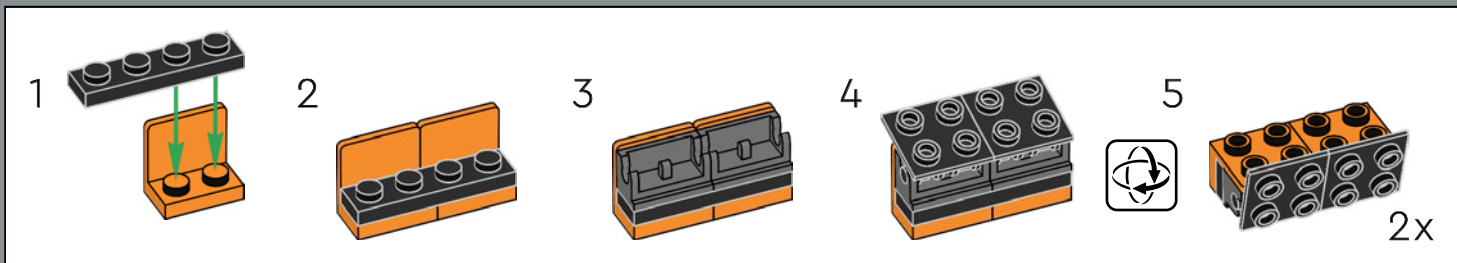
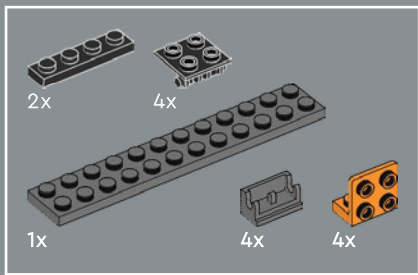

41

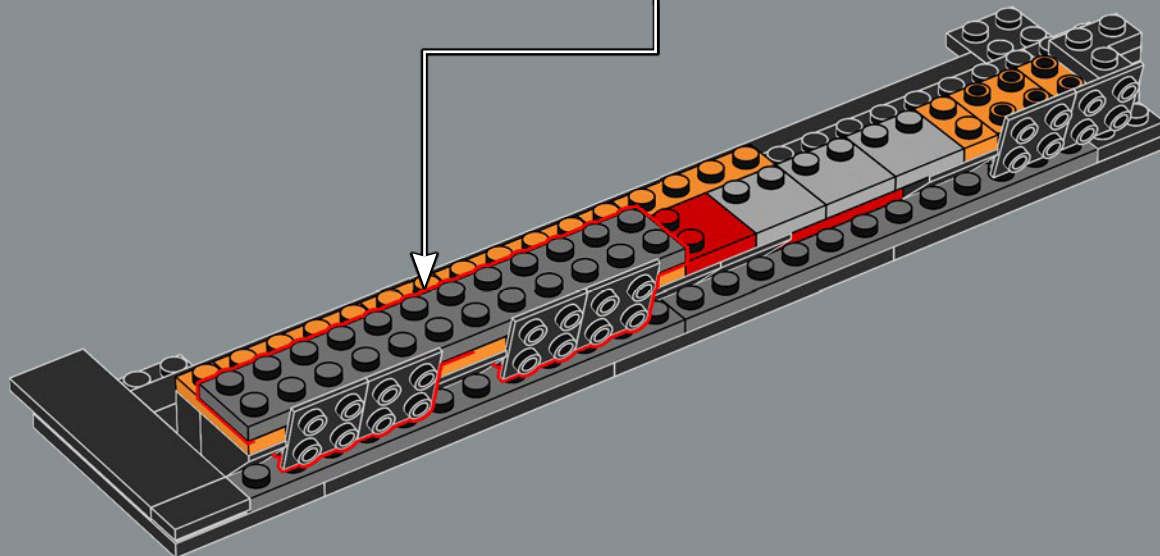
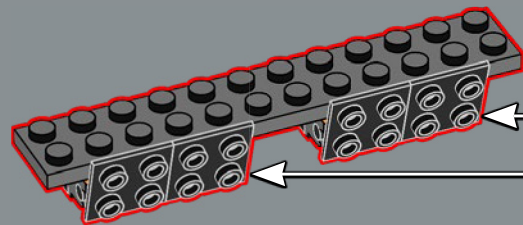

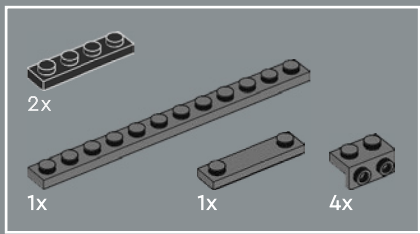

42

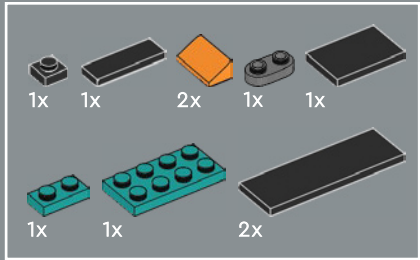
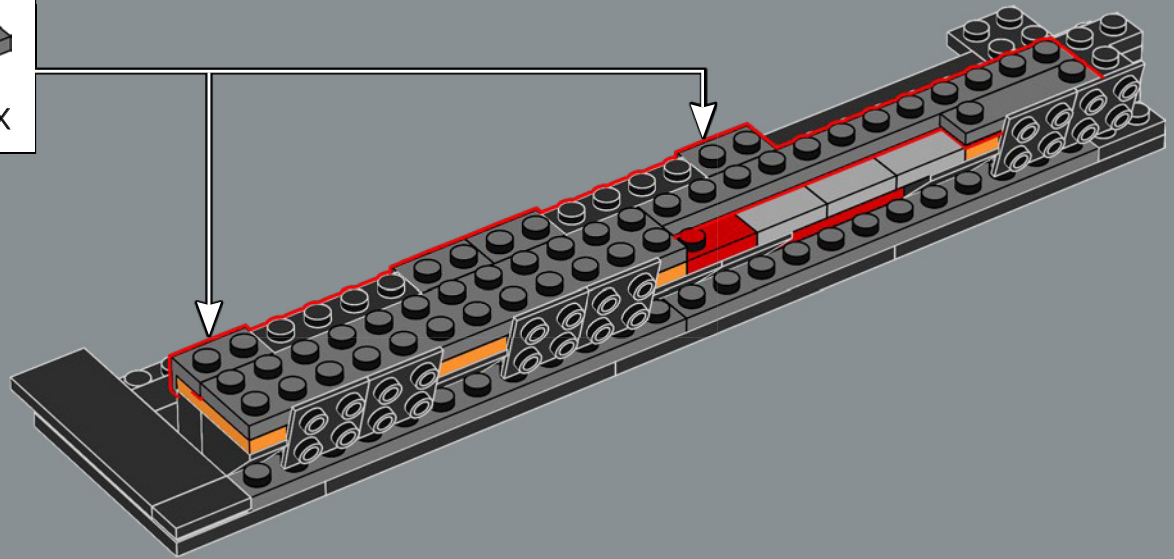
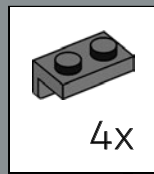

43

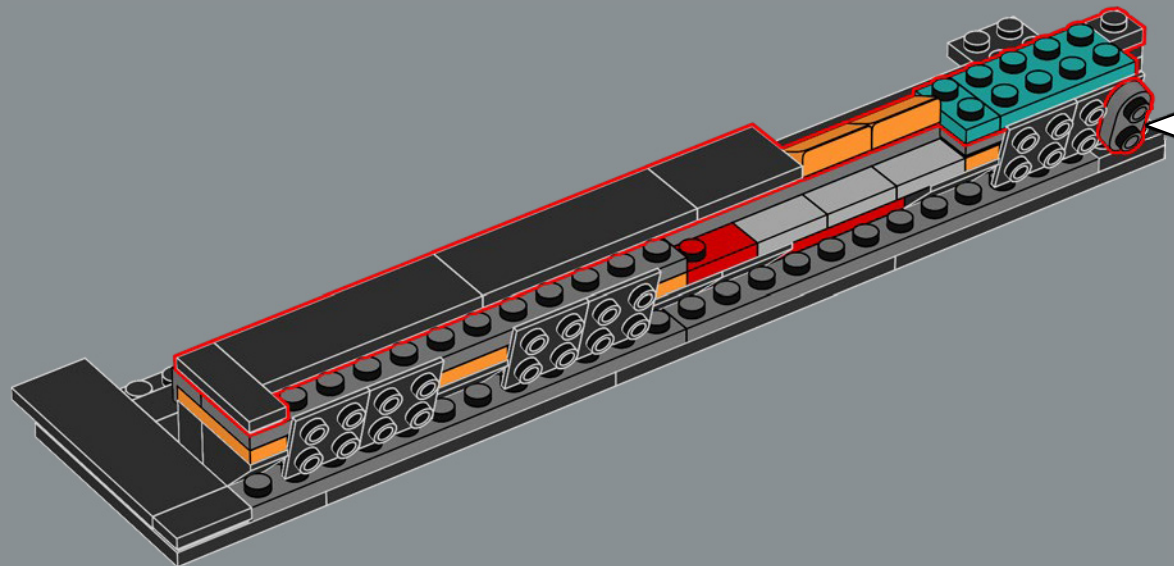

44

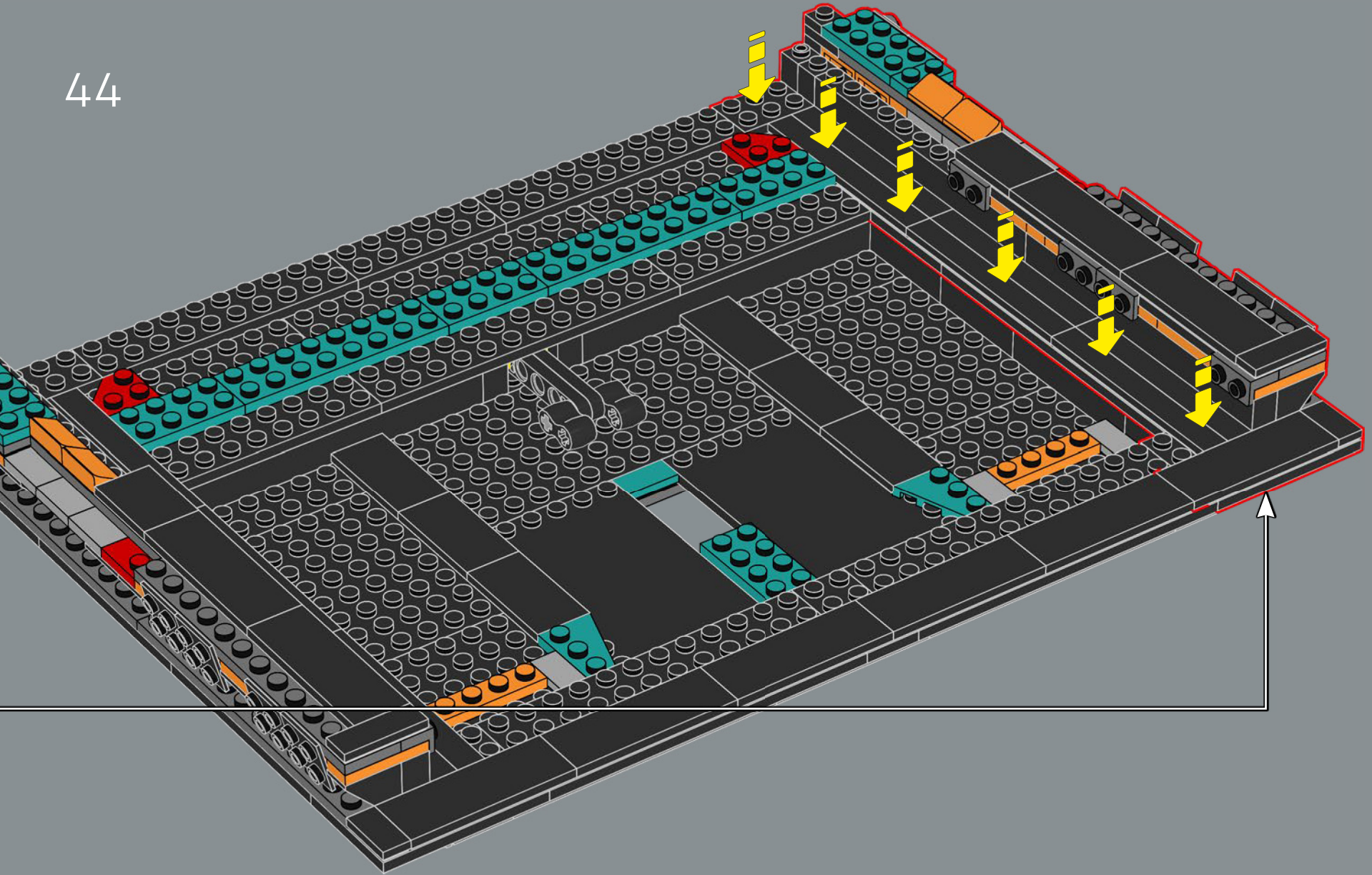



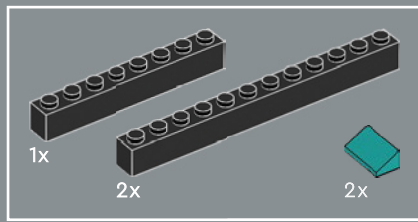

45

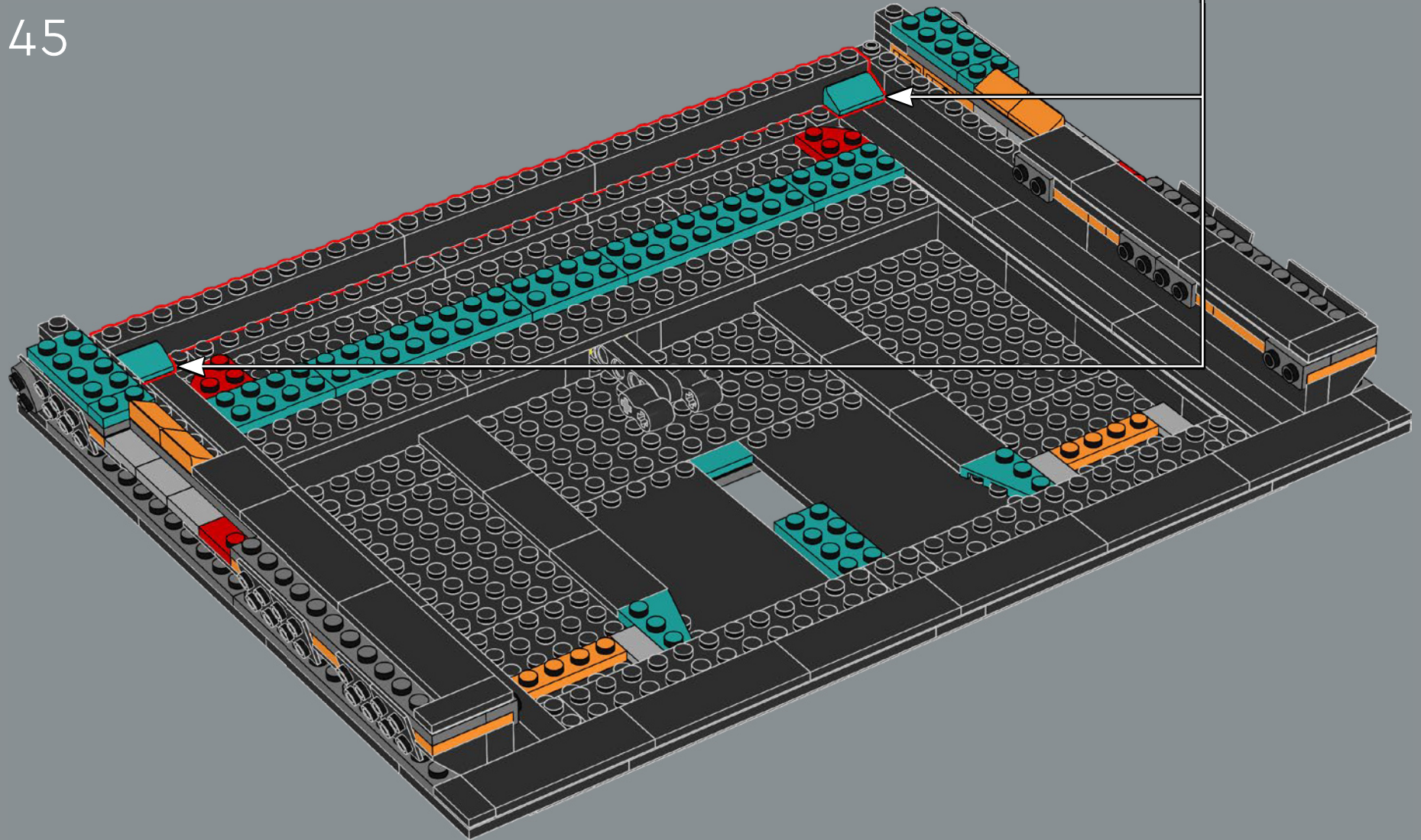
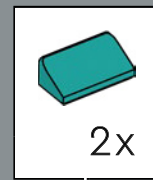

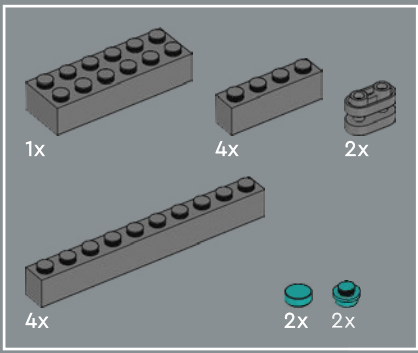

46

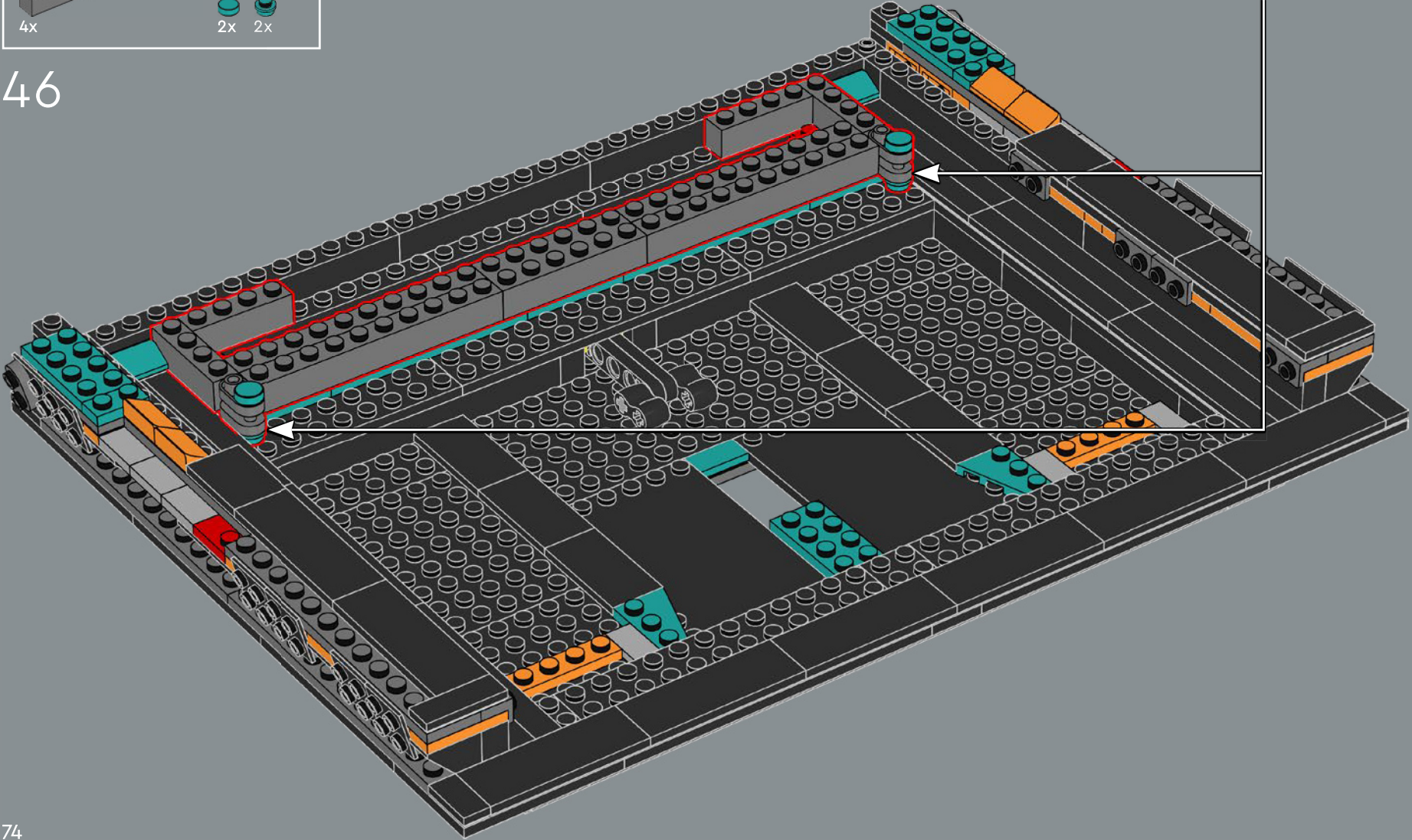
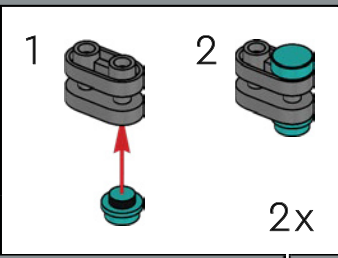

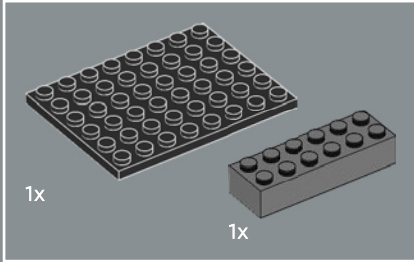
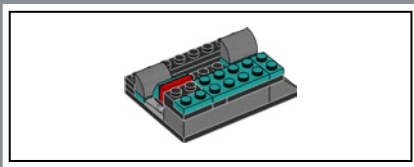

47

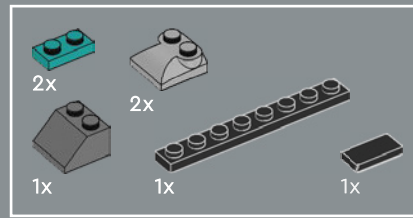
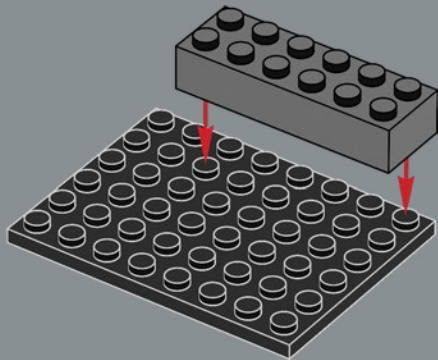

48

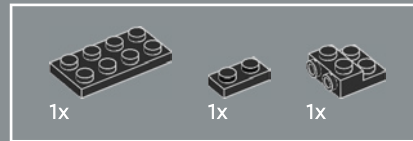
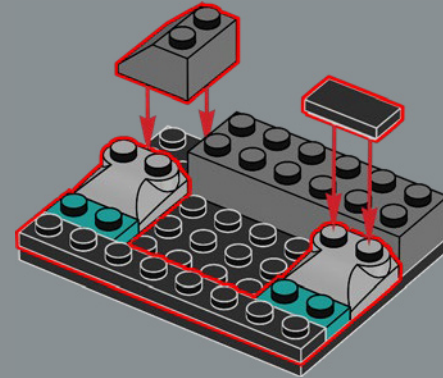

49

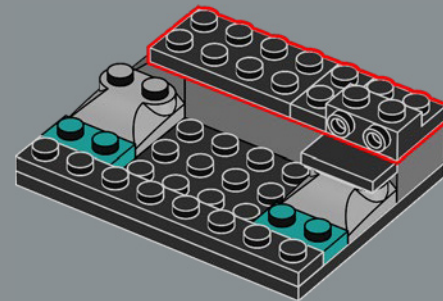

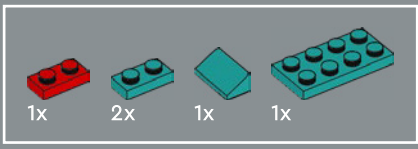

50

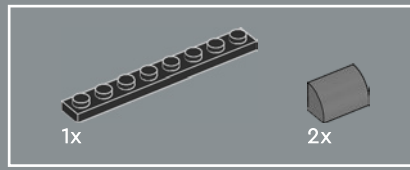
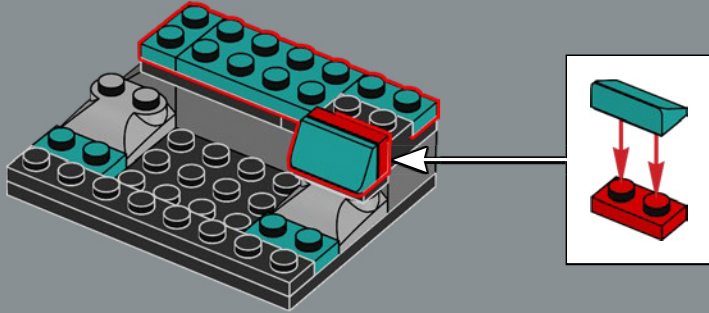

51

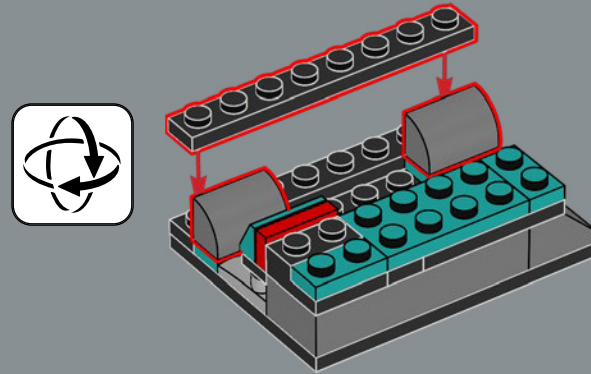

52

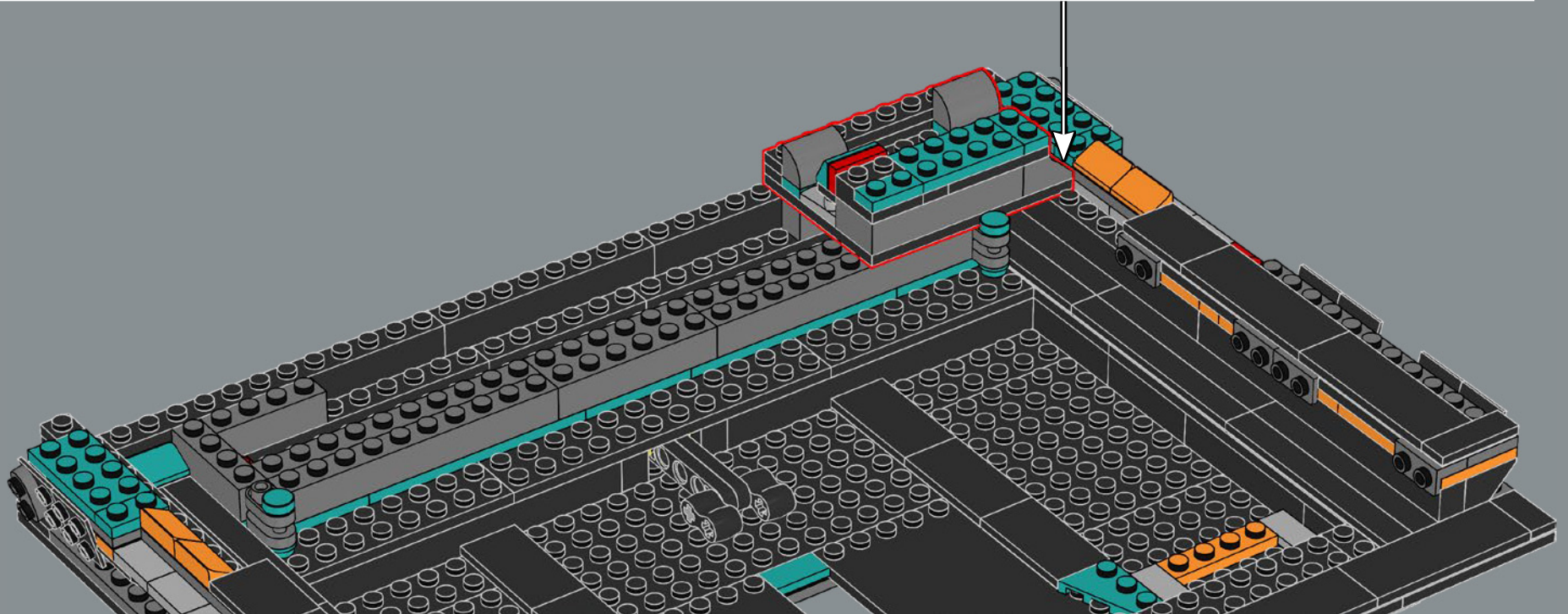

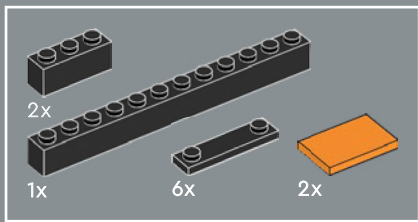

53

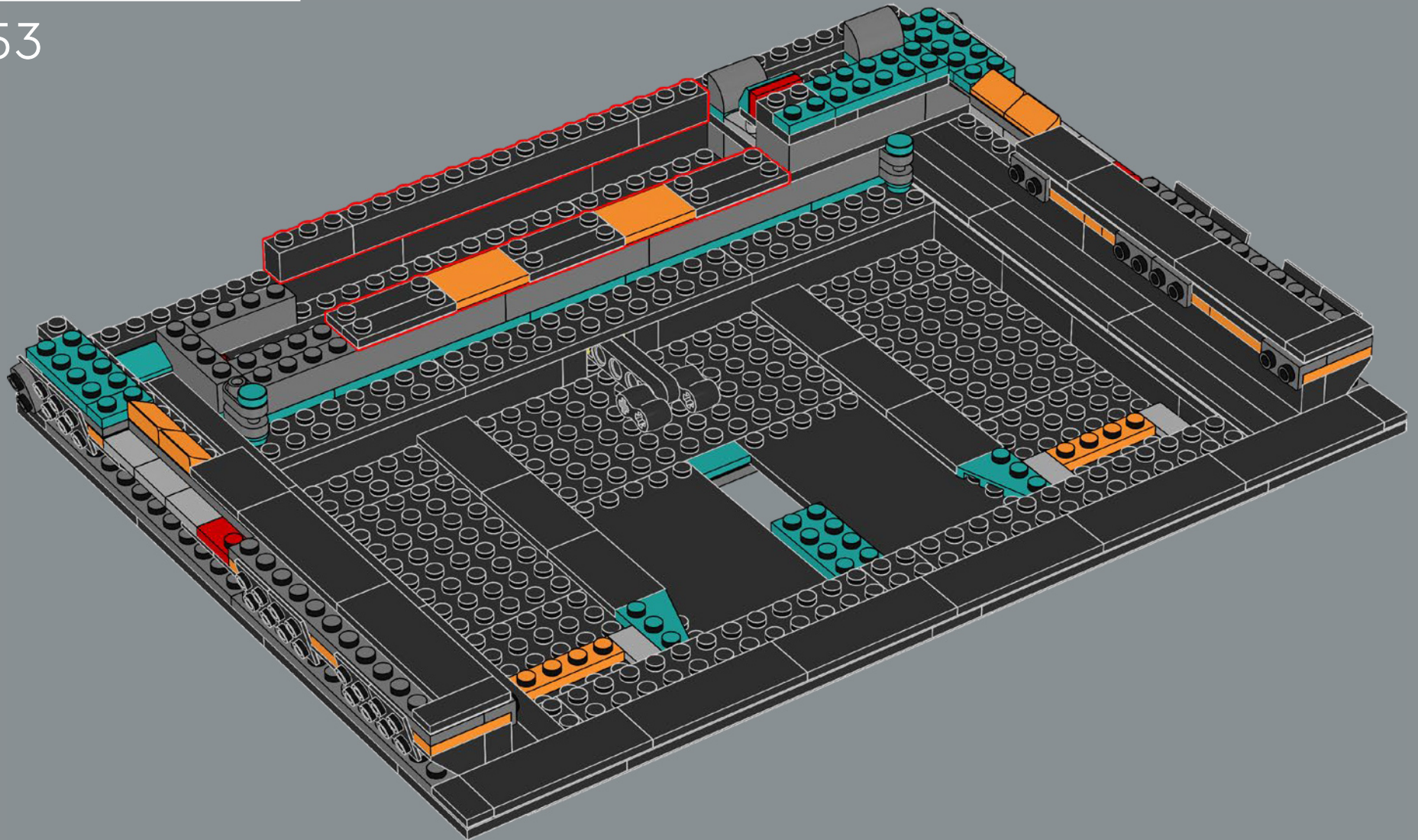

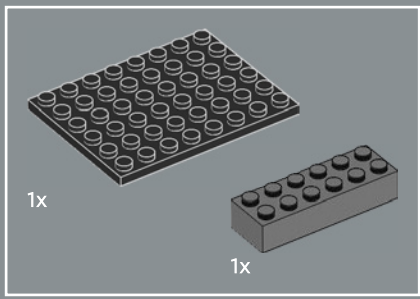

54

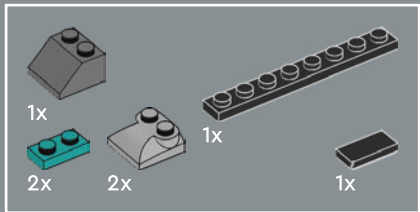
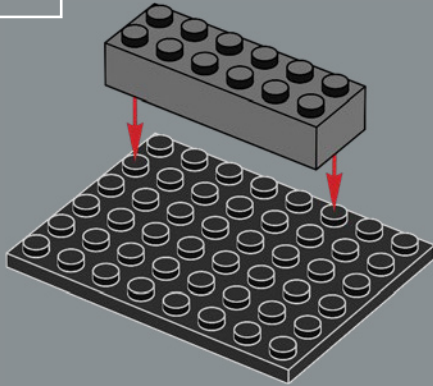

55

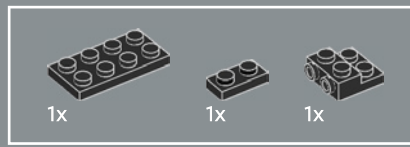
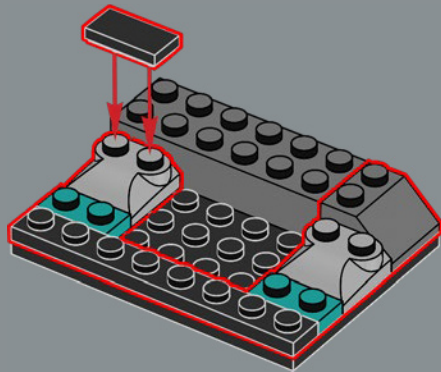

56

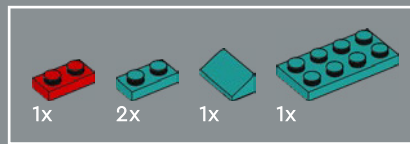
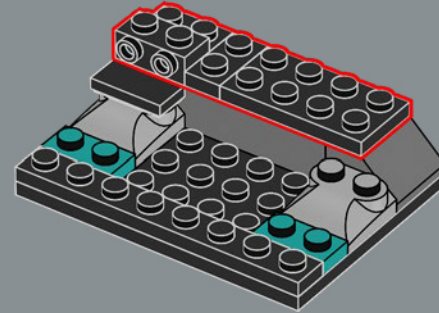

57

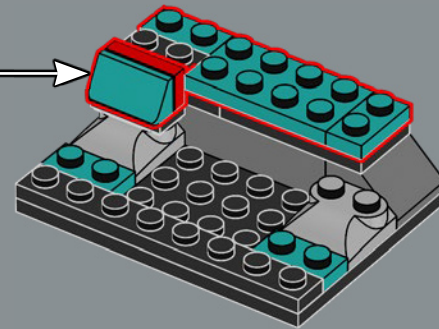
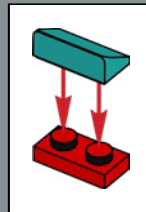

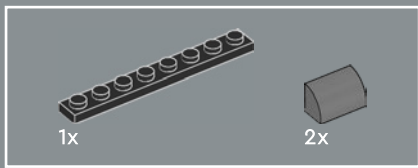

58

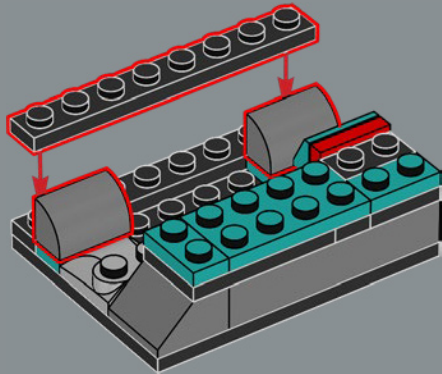

59

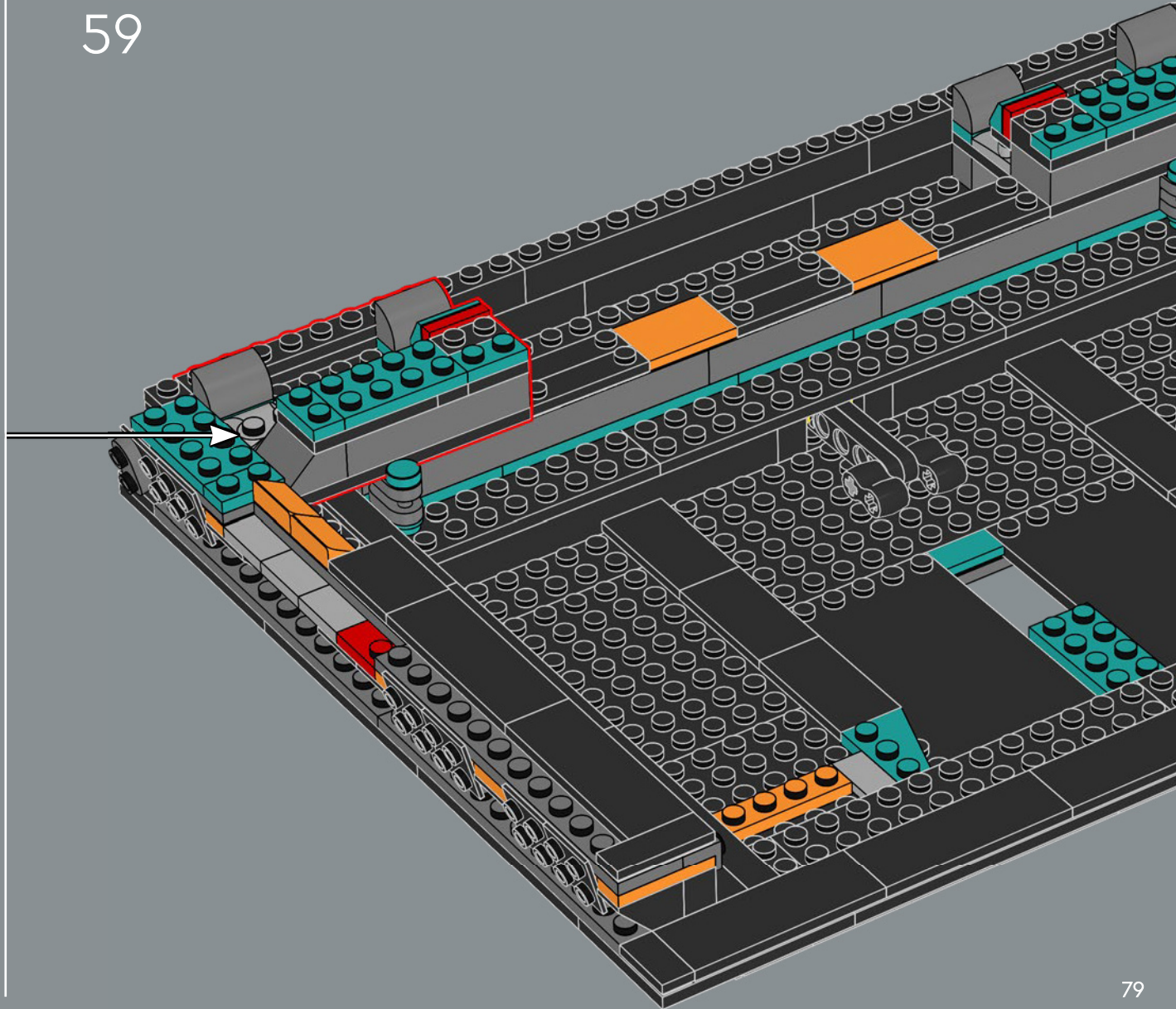

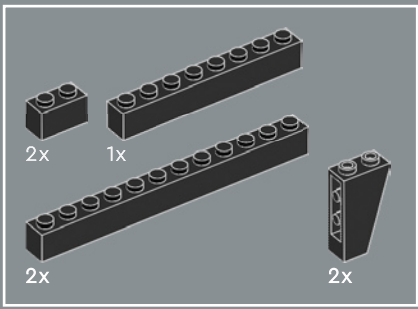

60

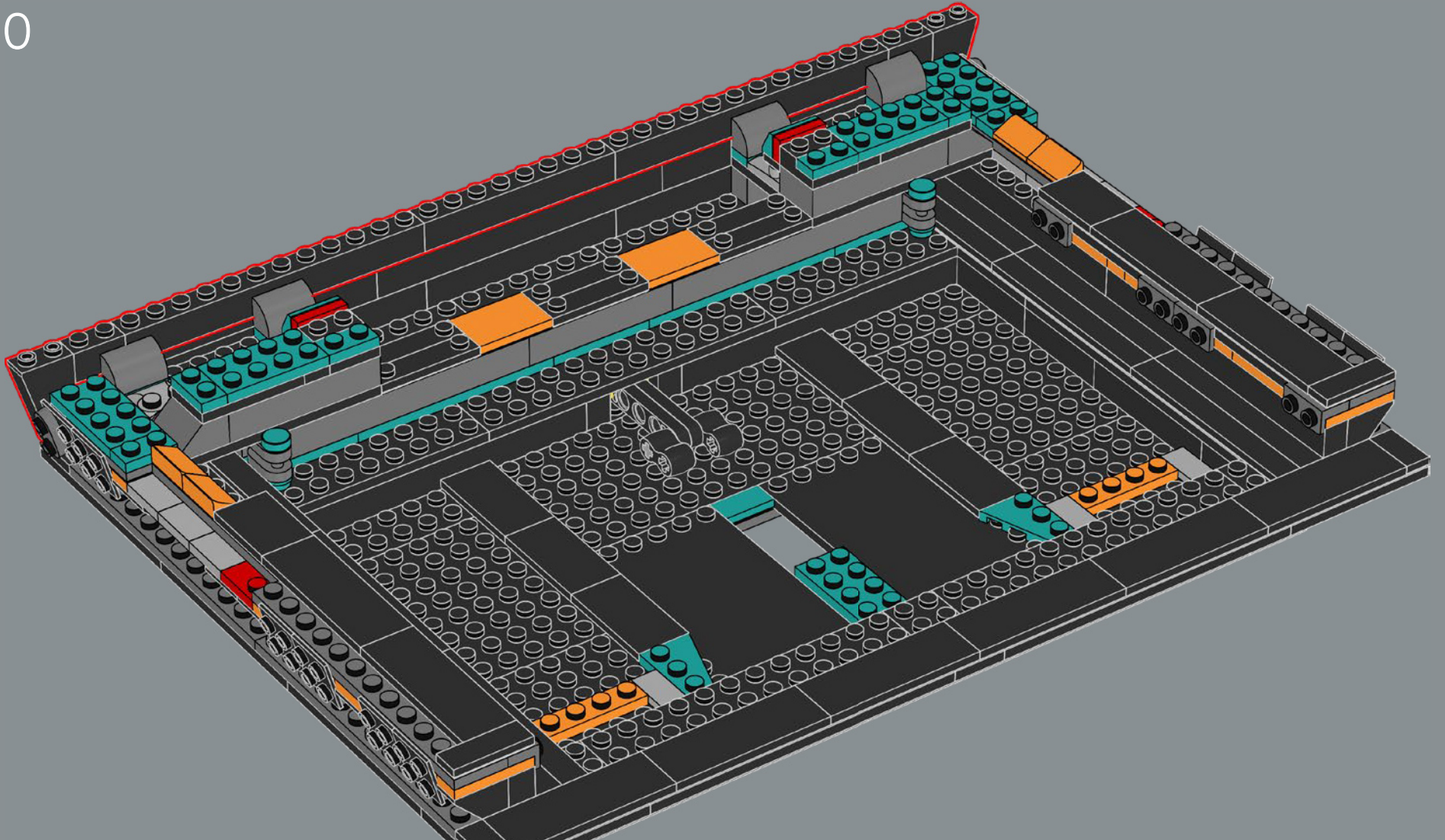

80

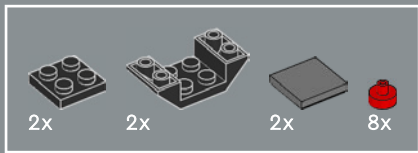

61

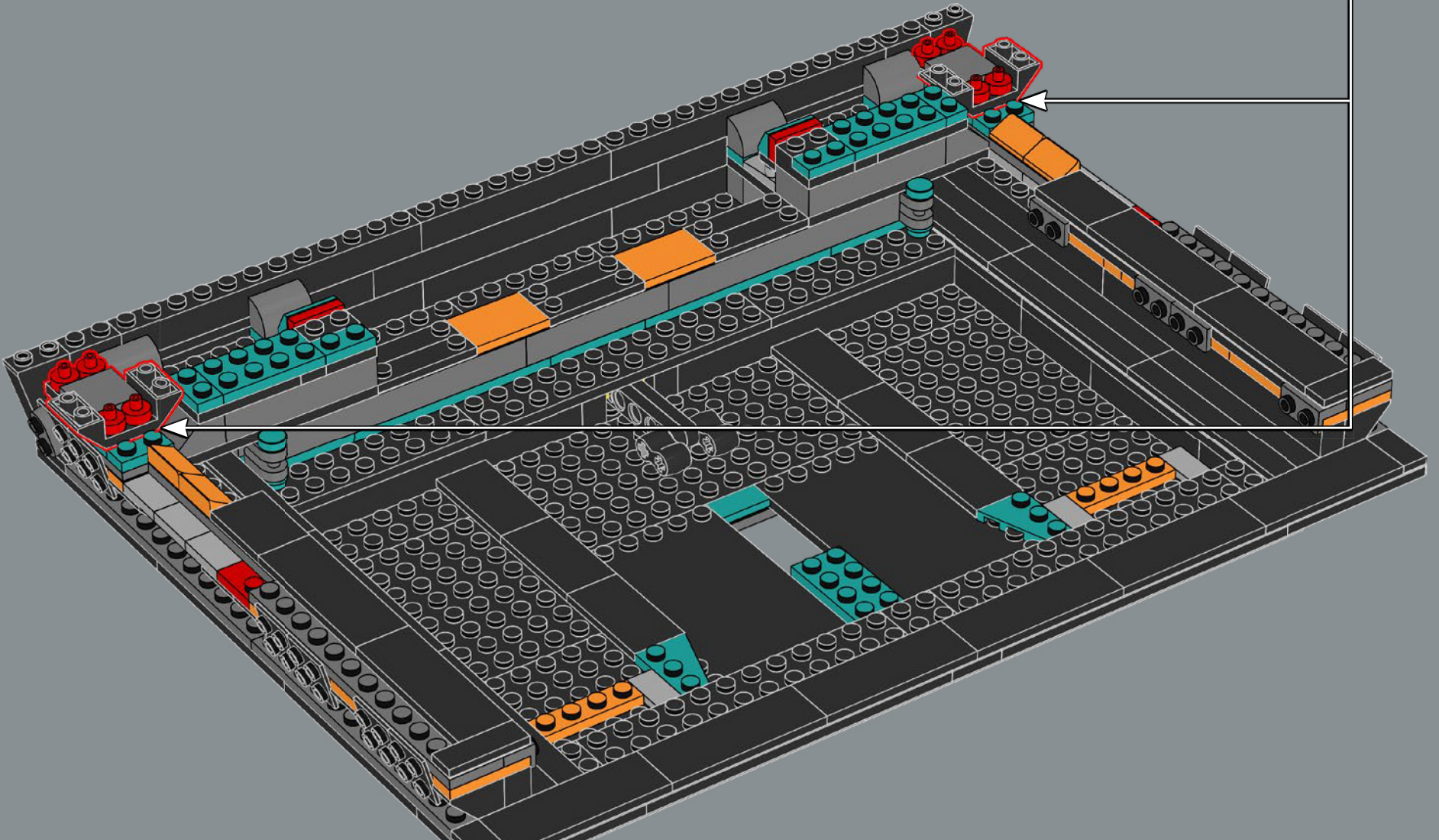
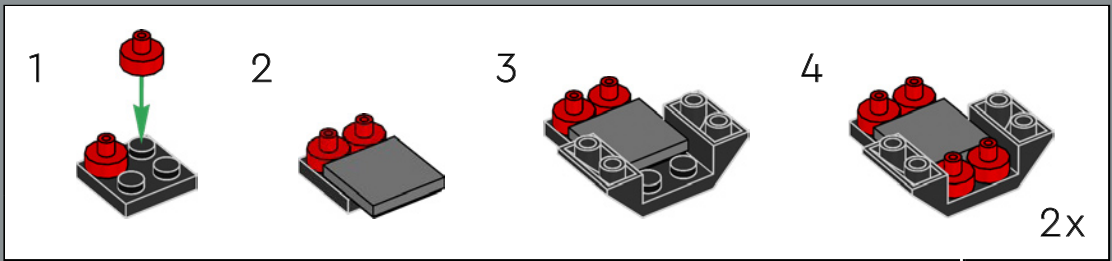

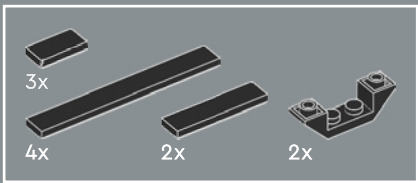

62

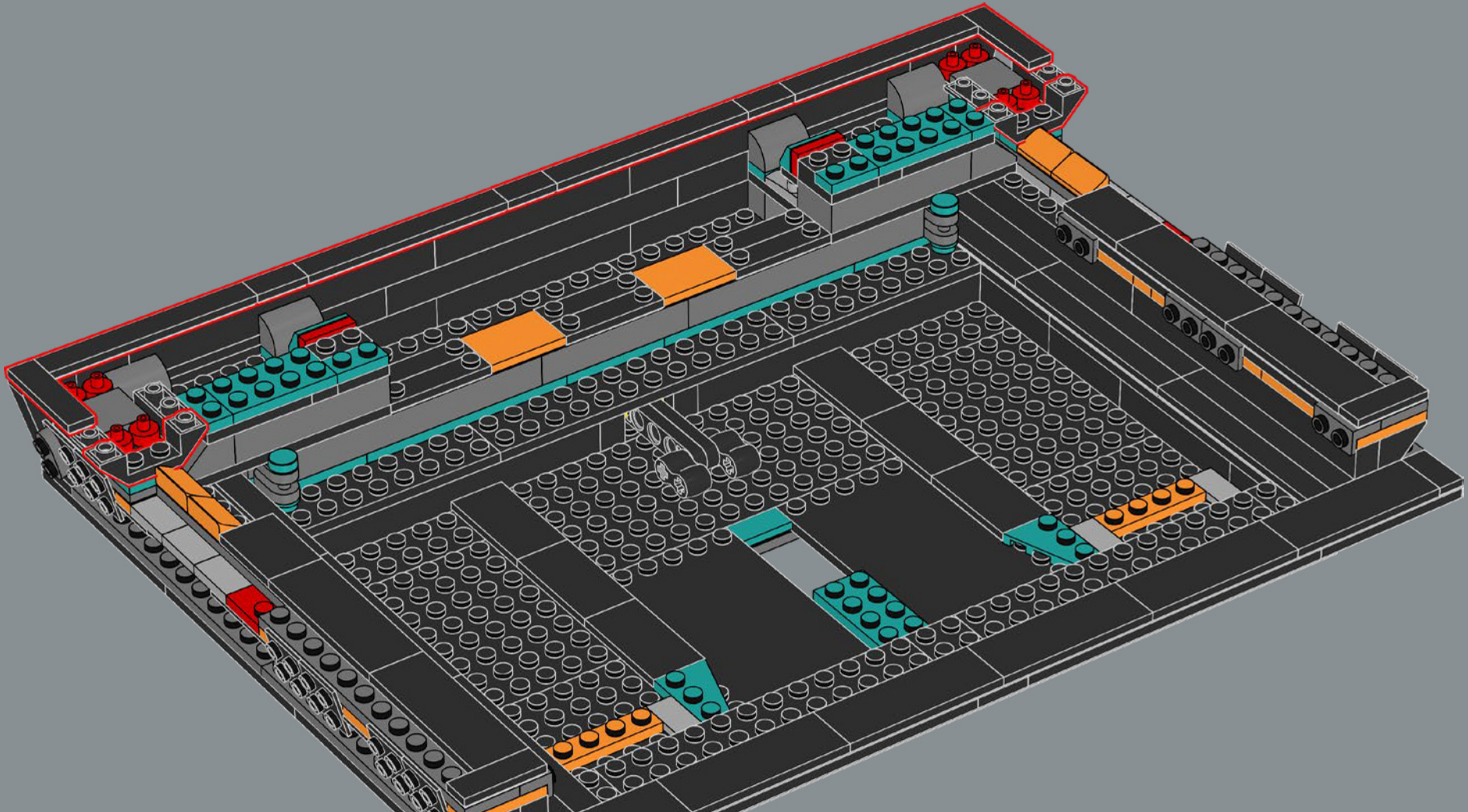

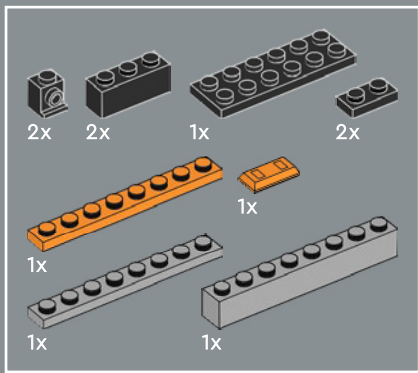

63

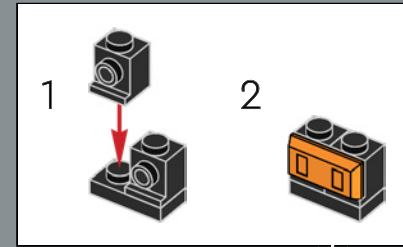
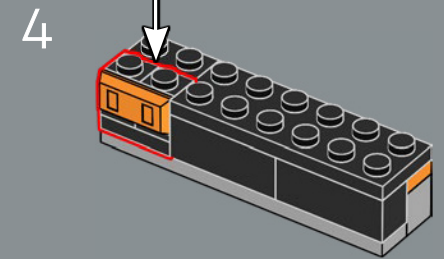
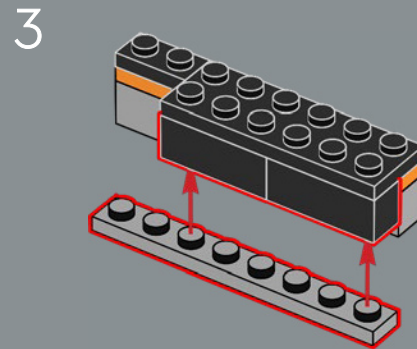
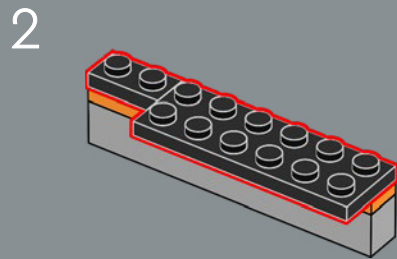
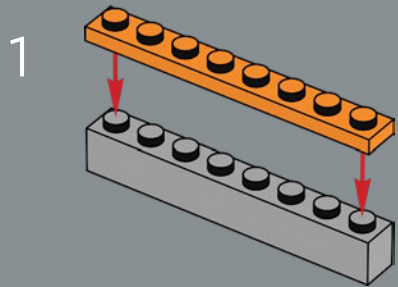

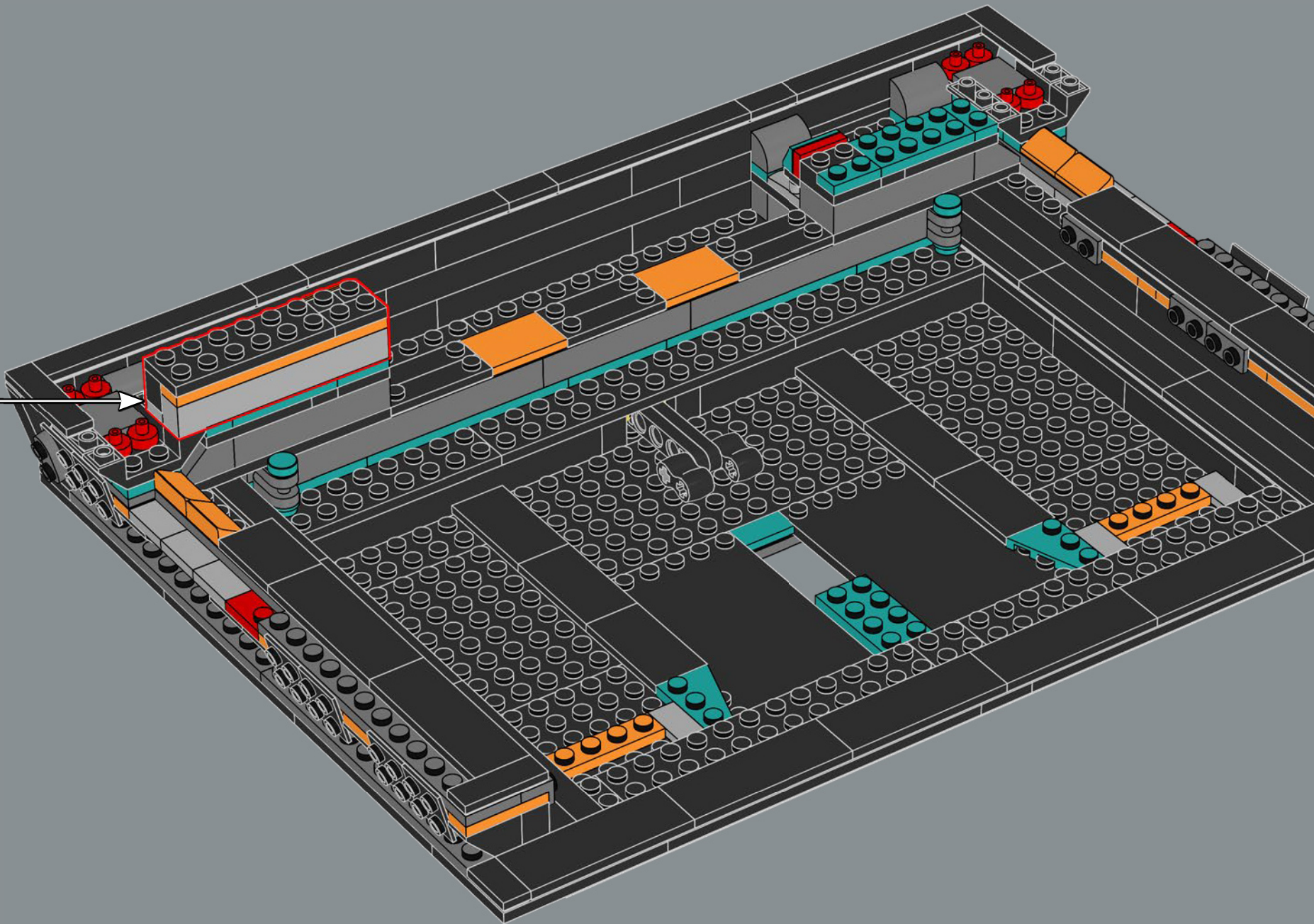

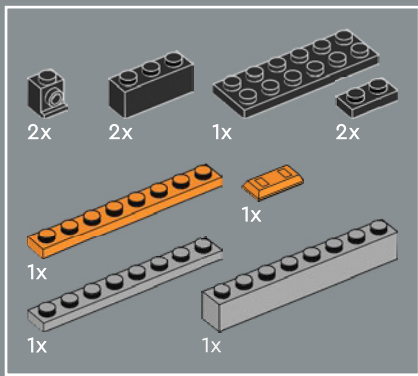

64

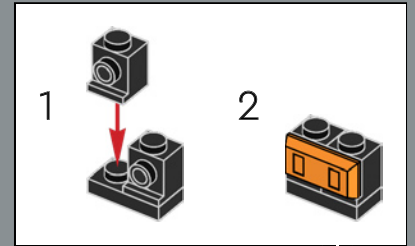
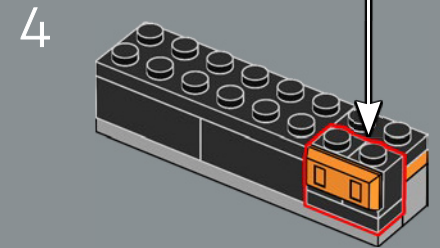
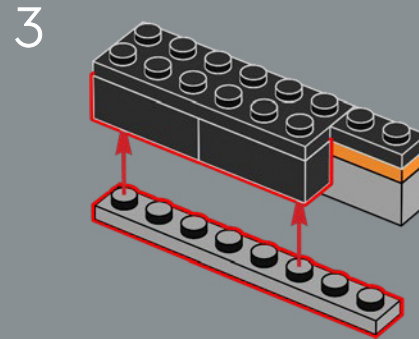
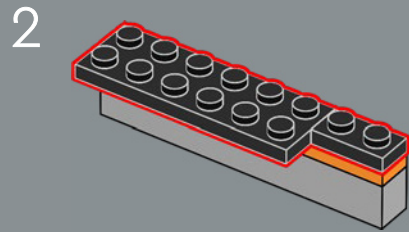
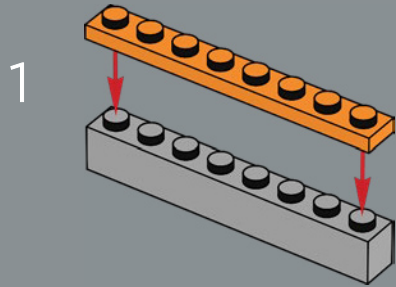

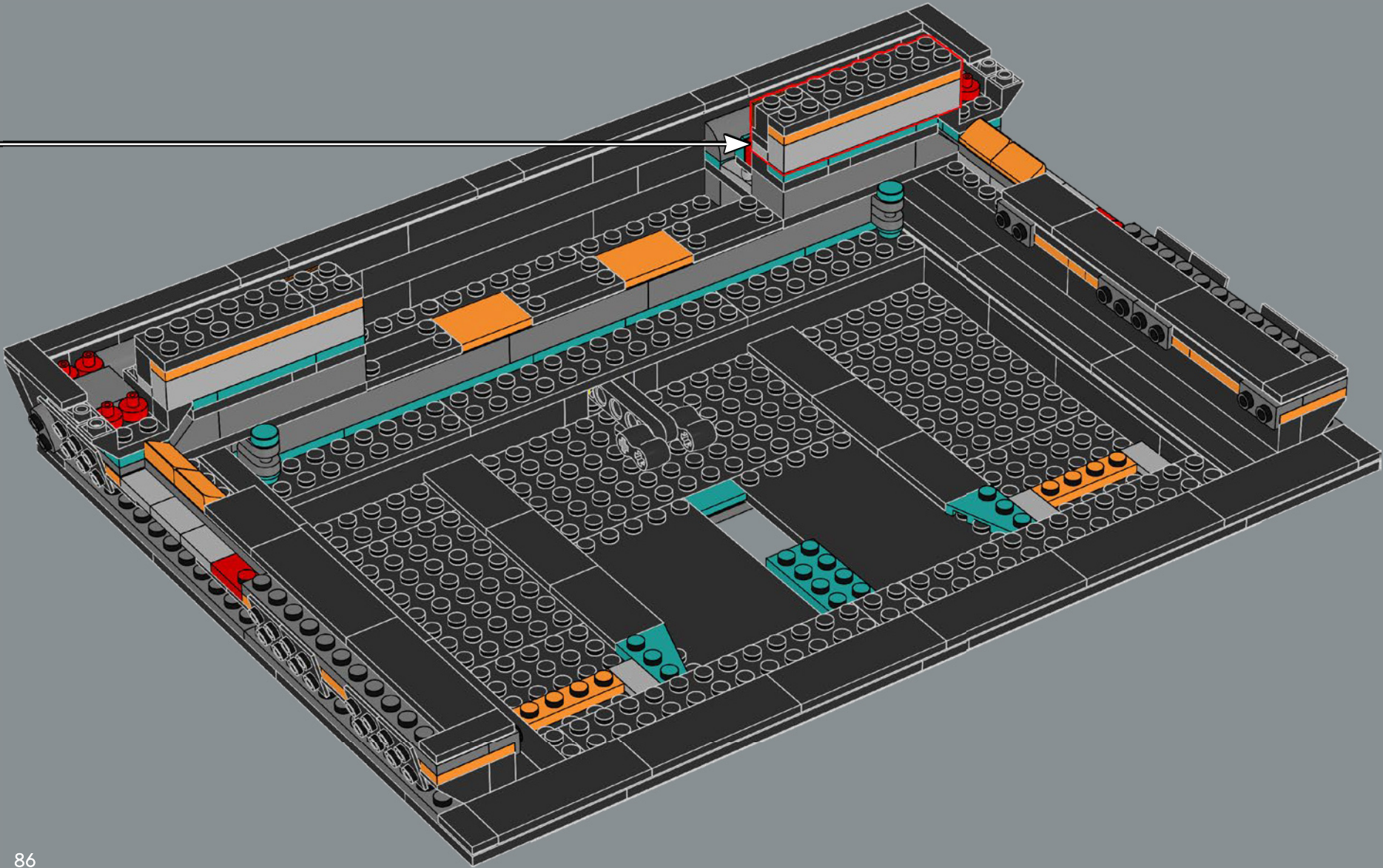

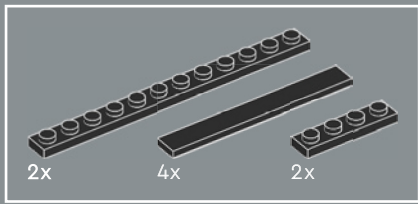

65

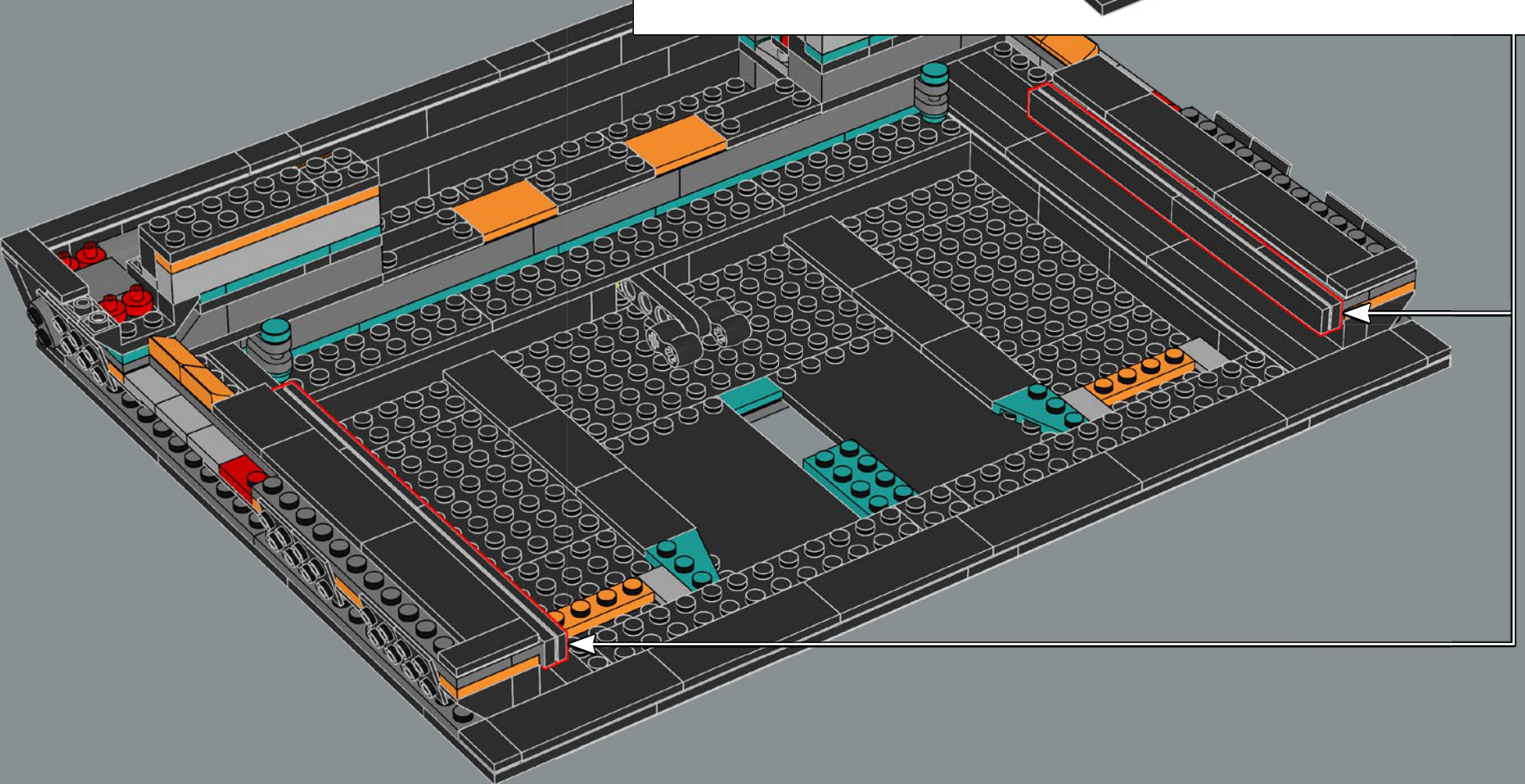
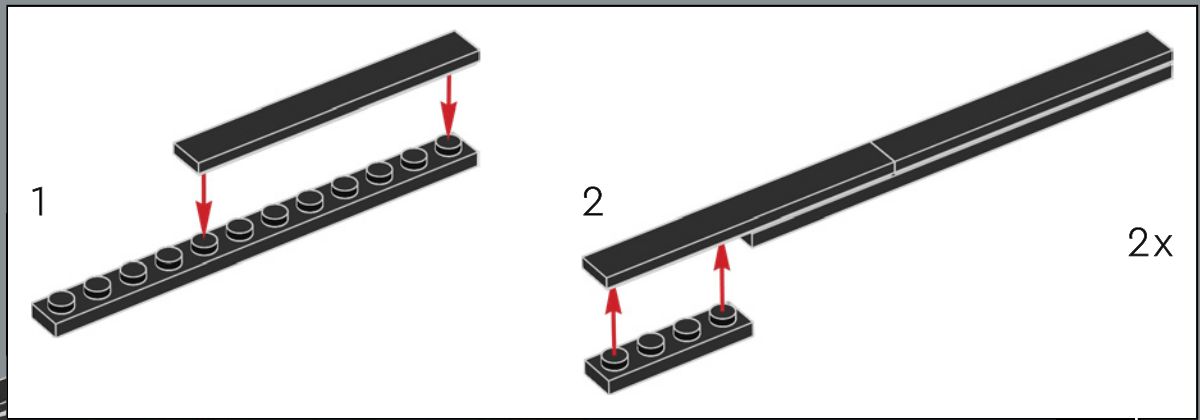

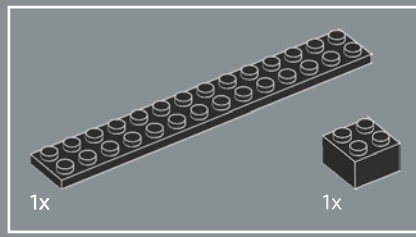

66

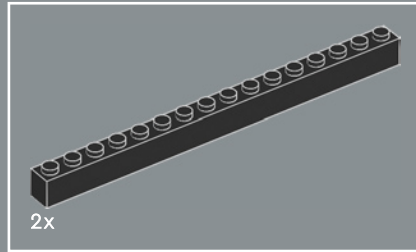
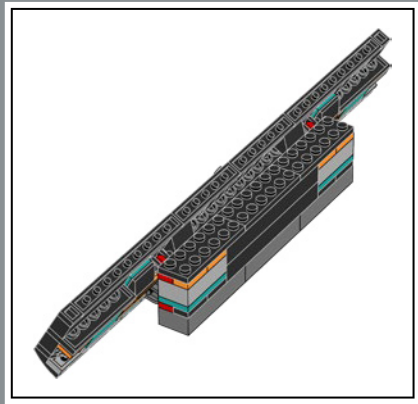
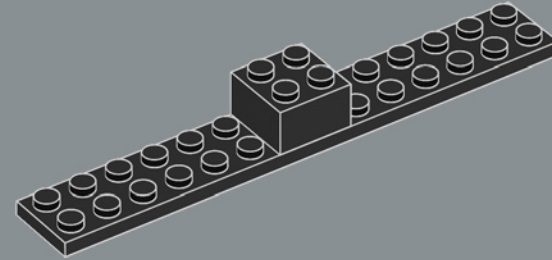

67

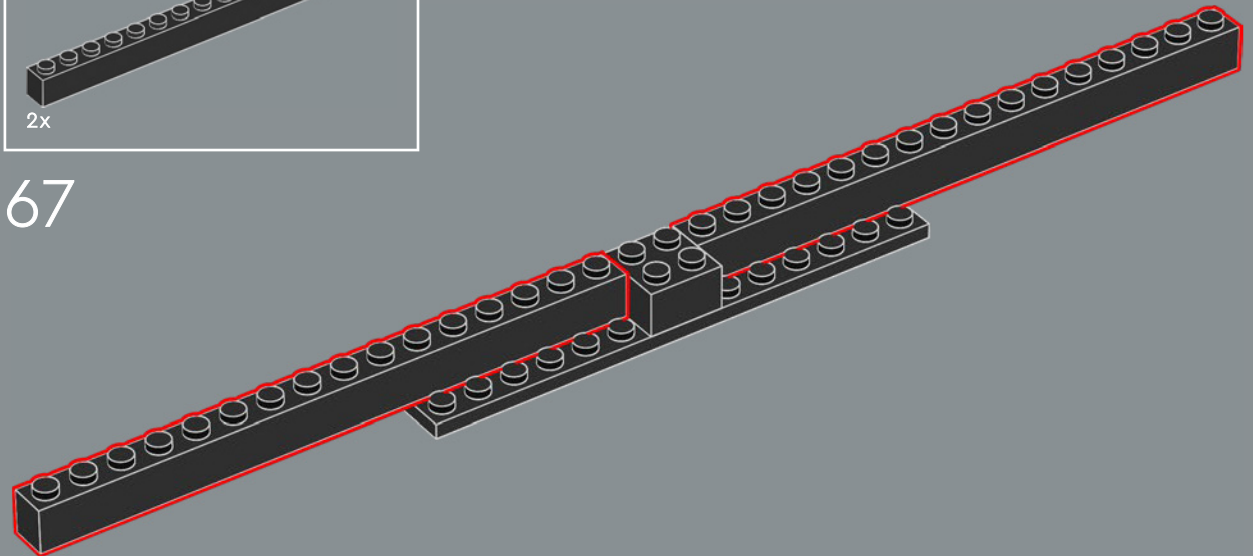

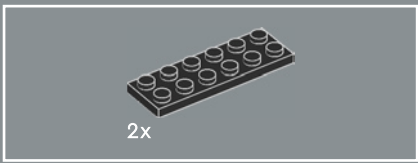

68

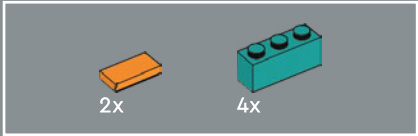
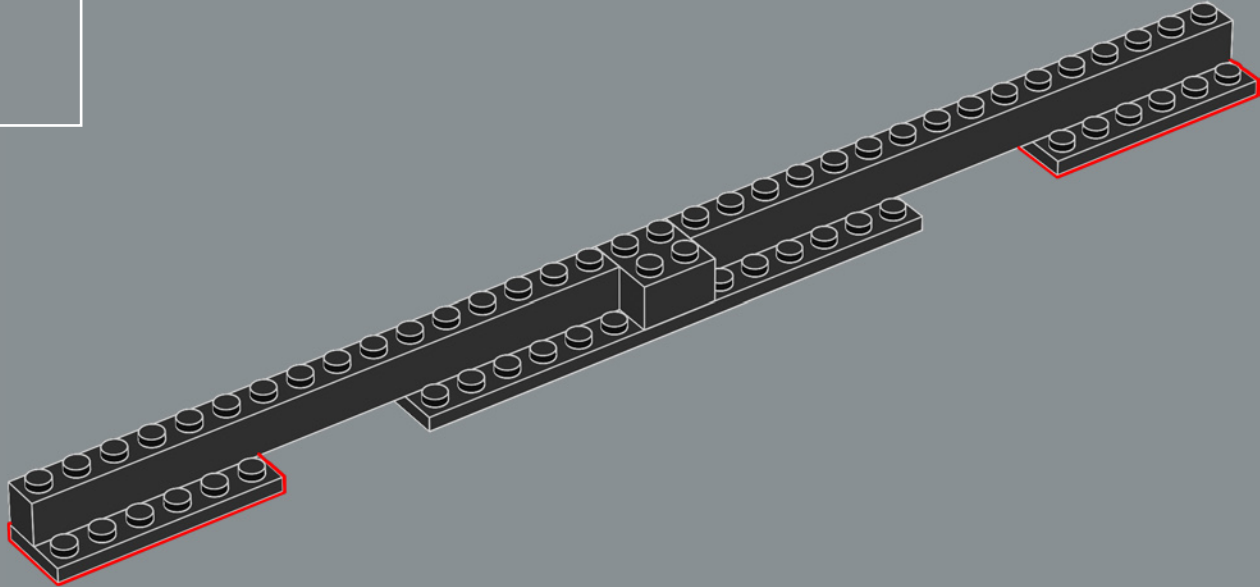

69

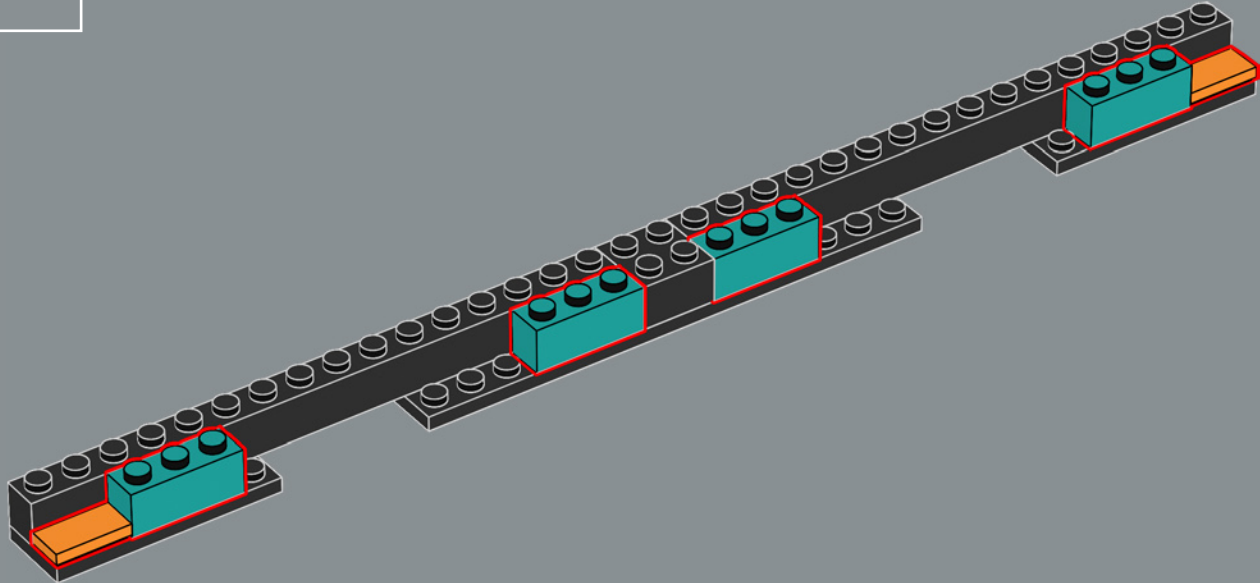

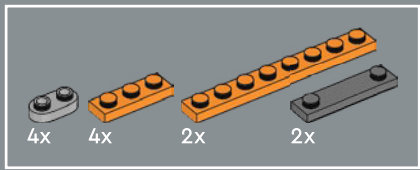

70

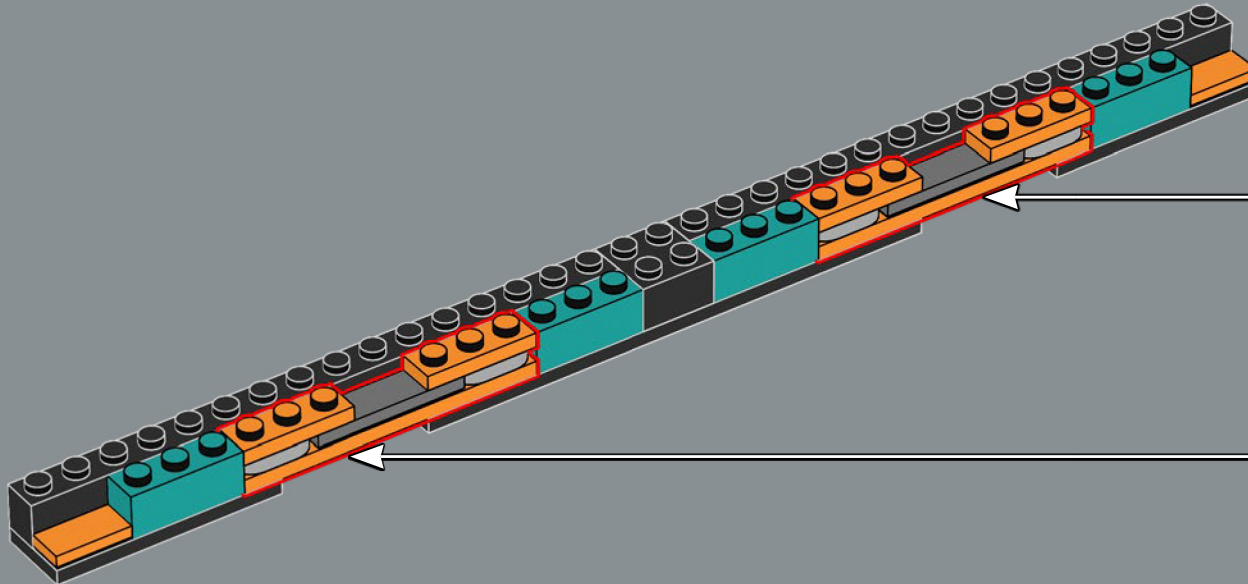
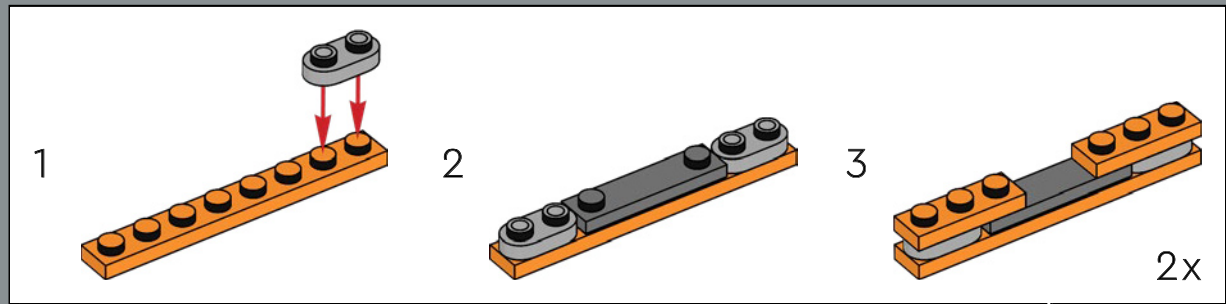

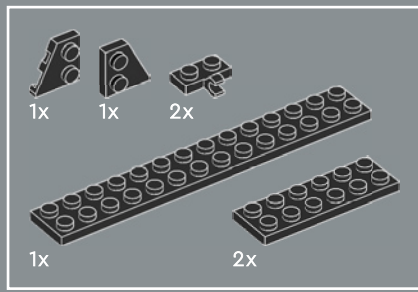

71

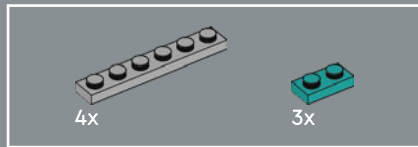
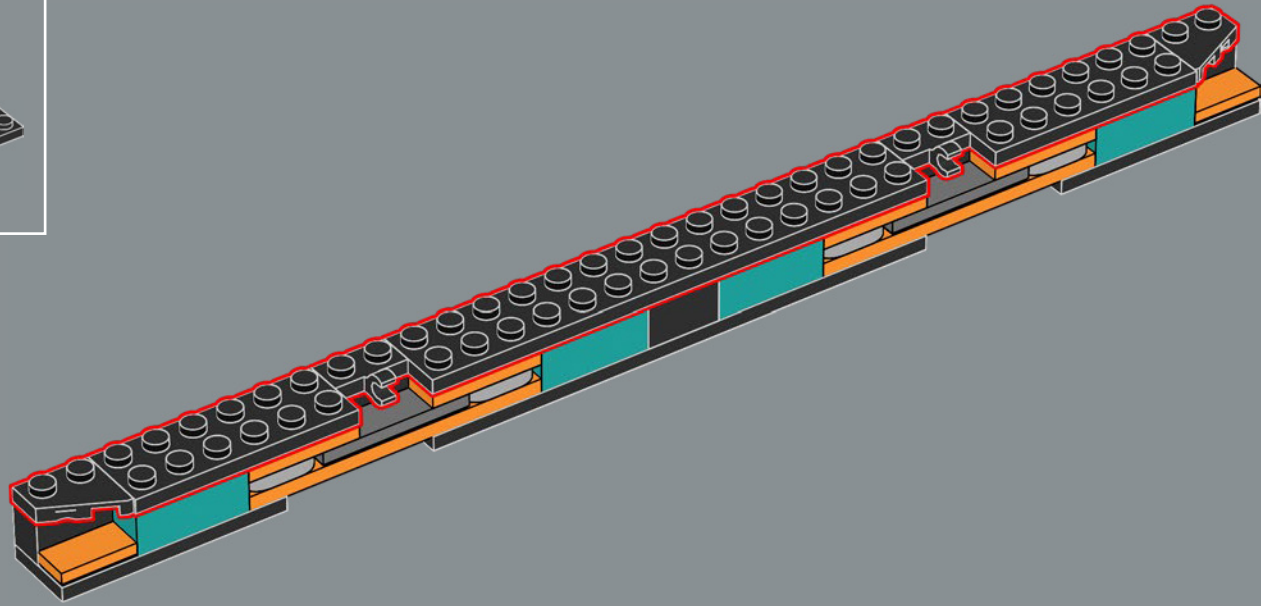

72

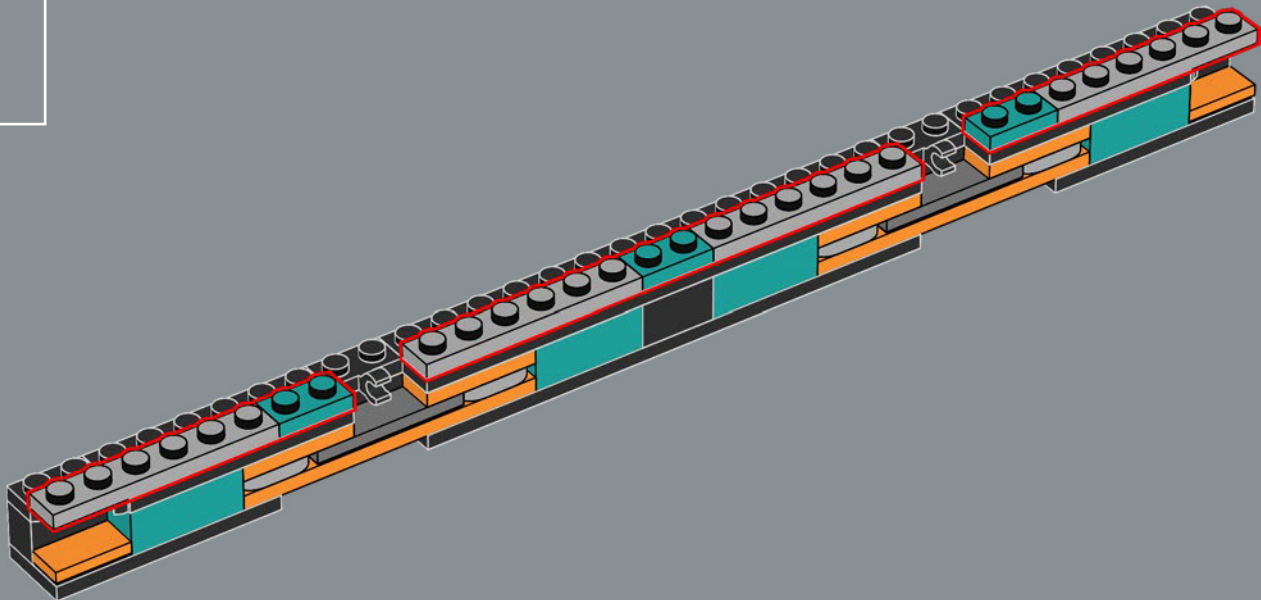

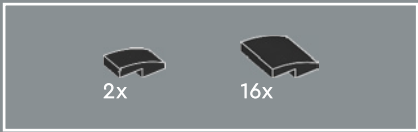

73

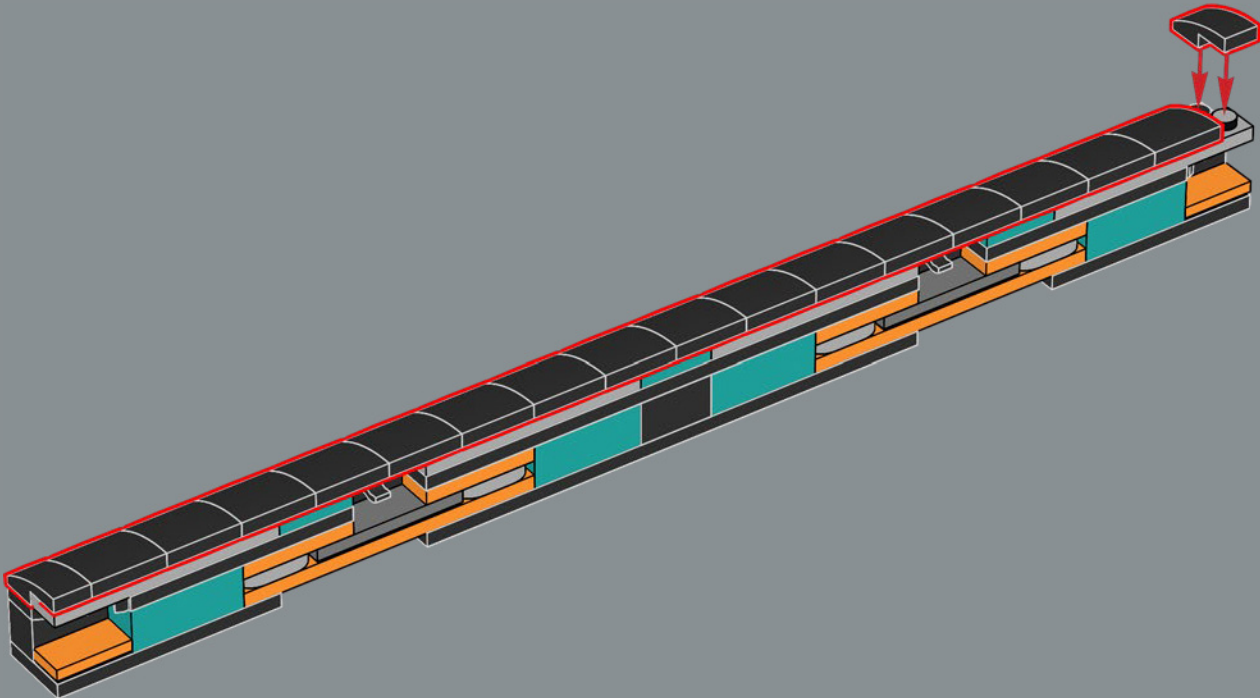

74

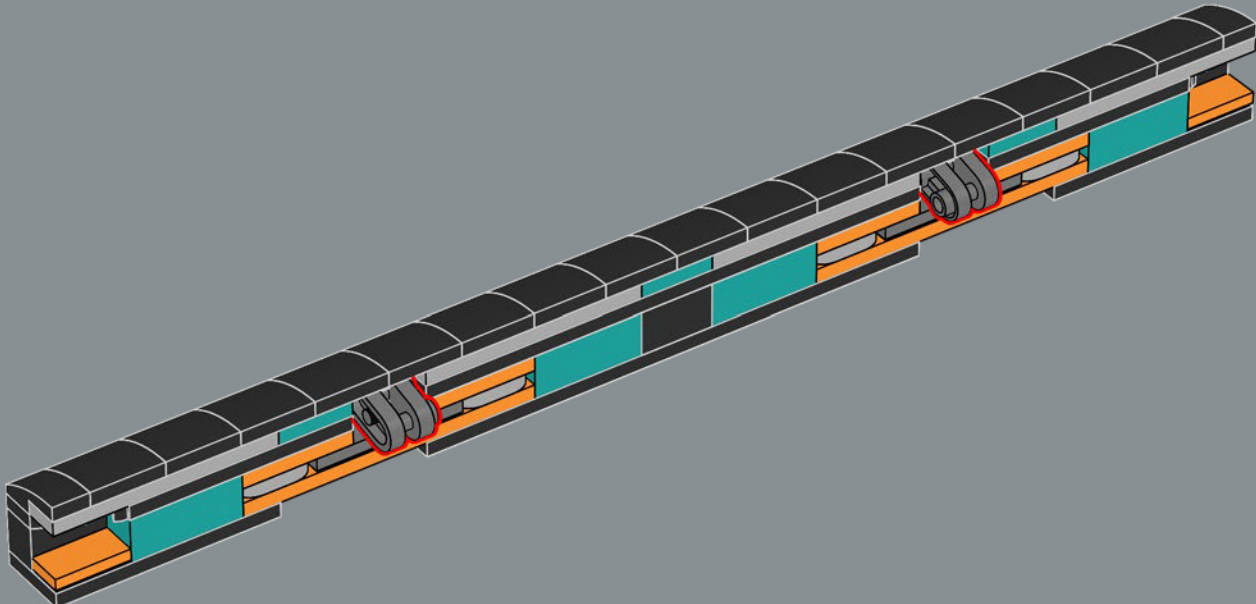

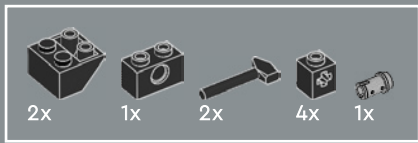

75

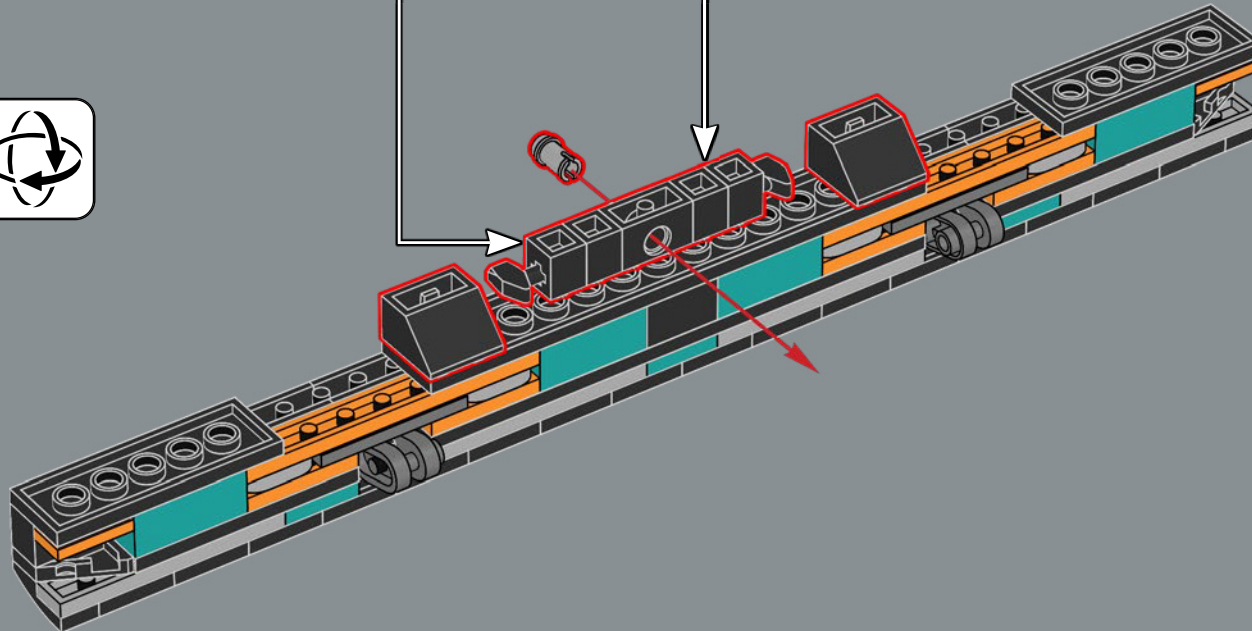
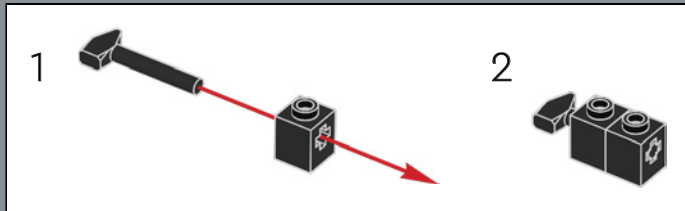
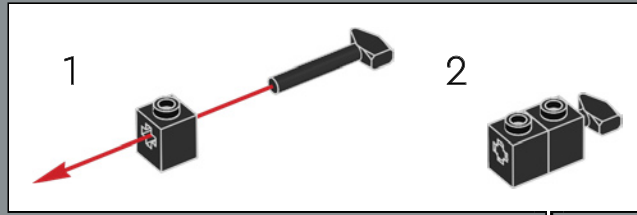

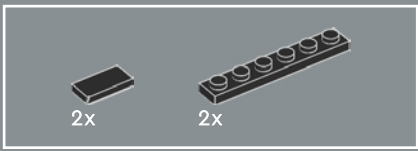

76

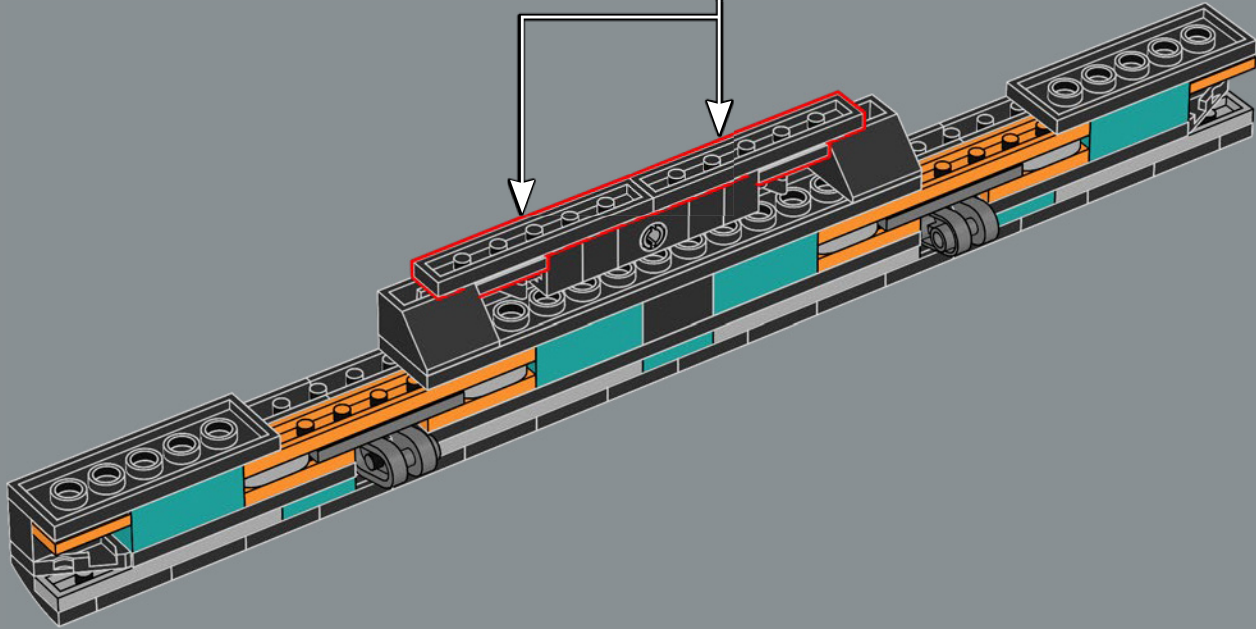
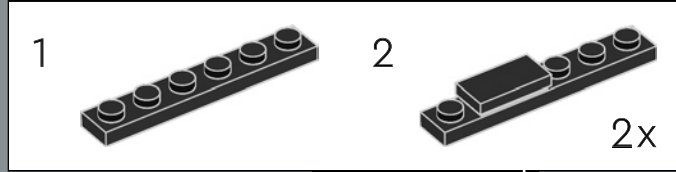

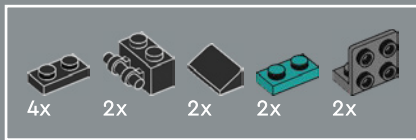

77

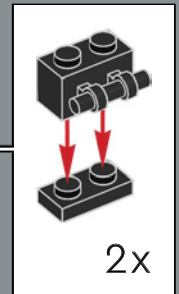
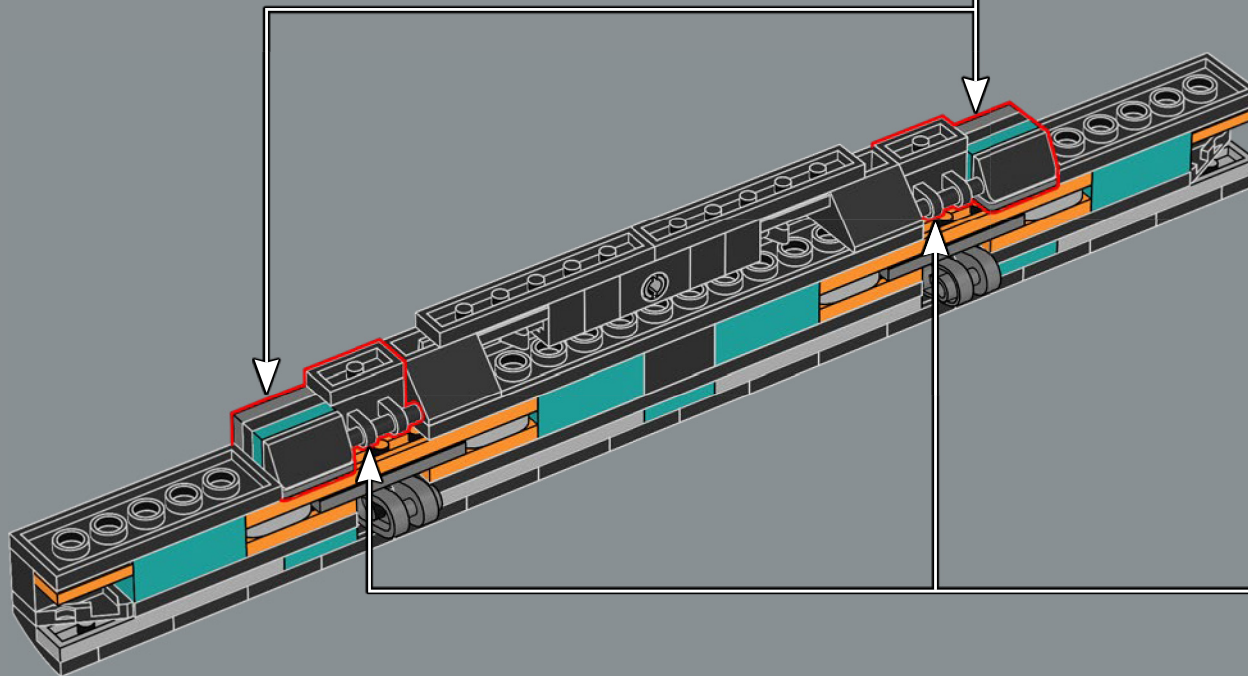
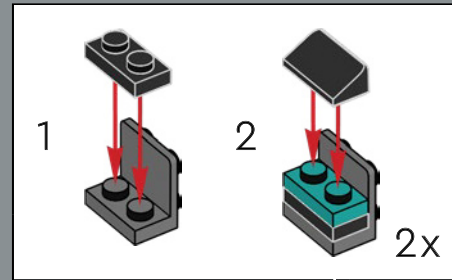

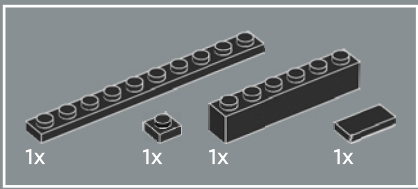

78

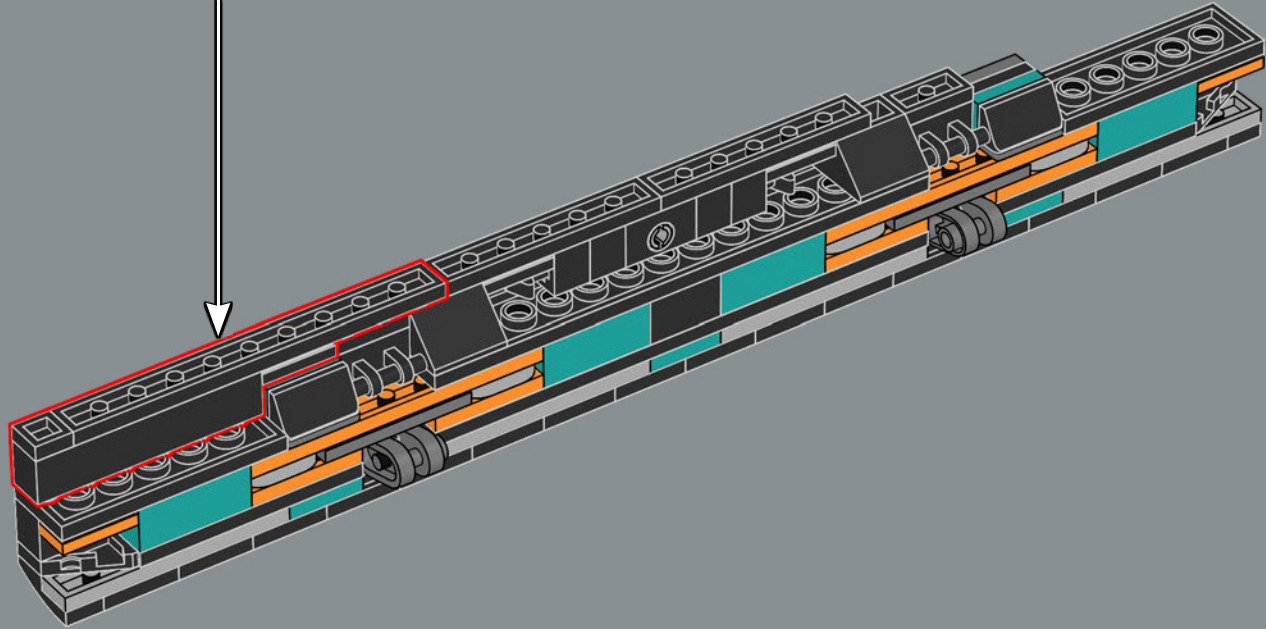
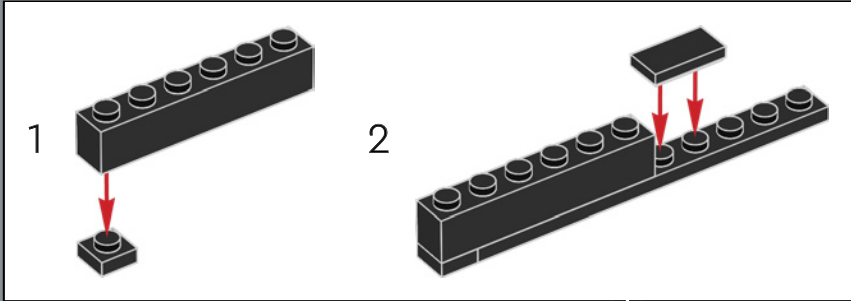

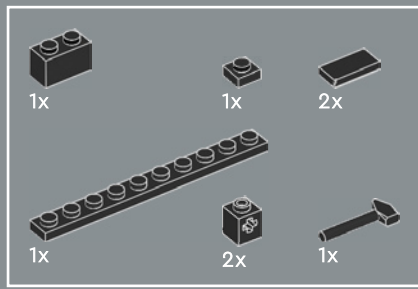

79

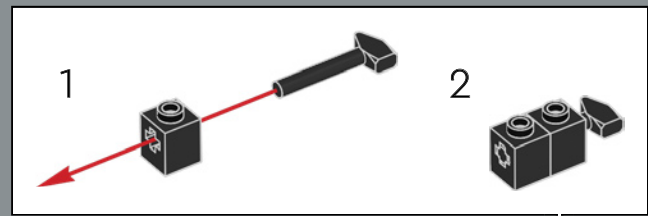
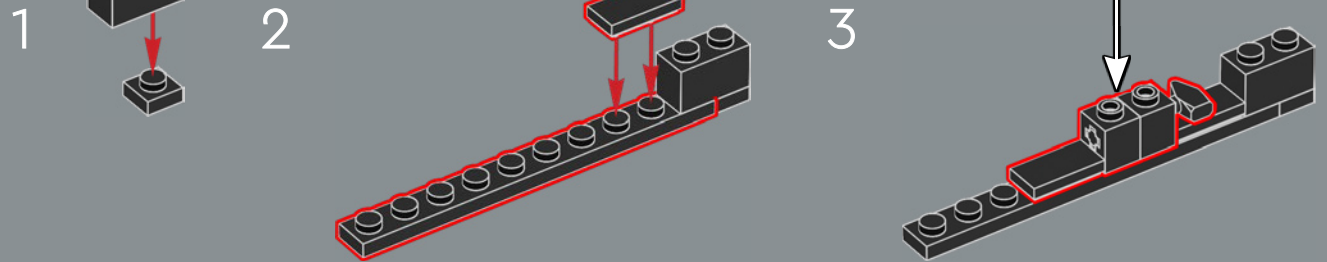

Introduced in 1980, the CX-2600A model of the VCS reduced the front switch count to four and relocated the two difficulty switches to the back of the console.

Lancé en 1980, le modèle CX-2600A de la VCS compte quatre commutateurs à l'avant, et les deux commutateurs de difficulté se trouvent maintenant à l'arrière de la console.

Introducido en 1980, el modelo CX-2600A del VCS redujo el número de interruptores frontales a cuatro y trasladó los dos interruptores de dificultad a la parte posterior de la consola.

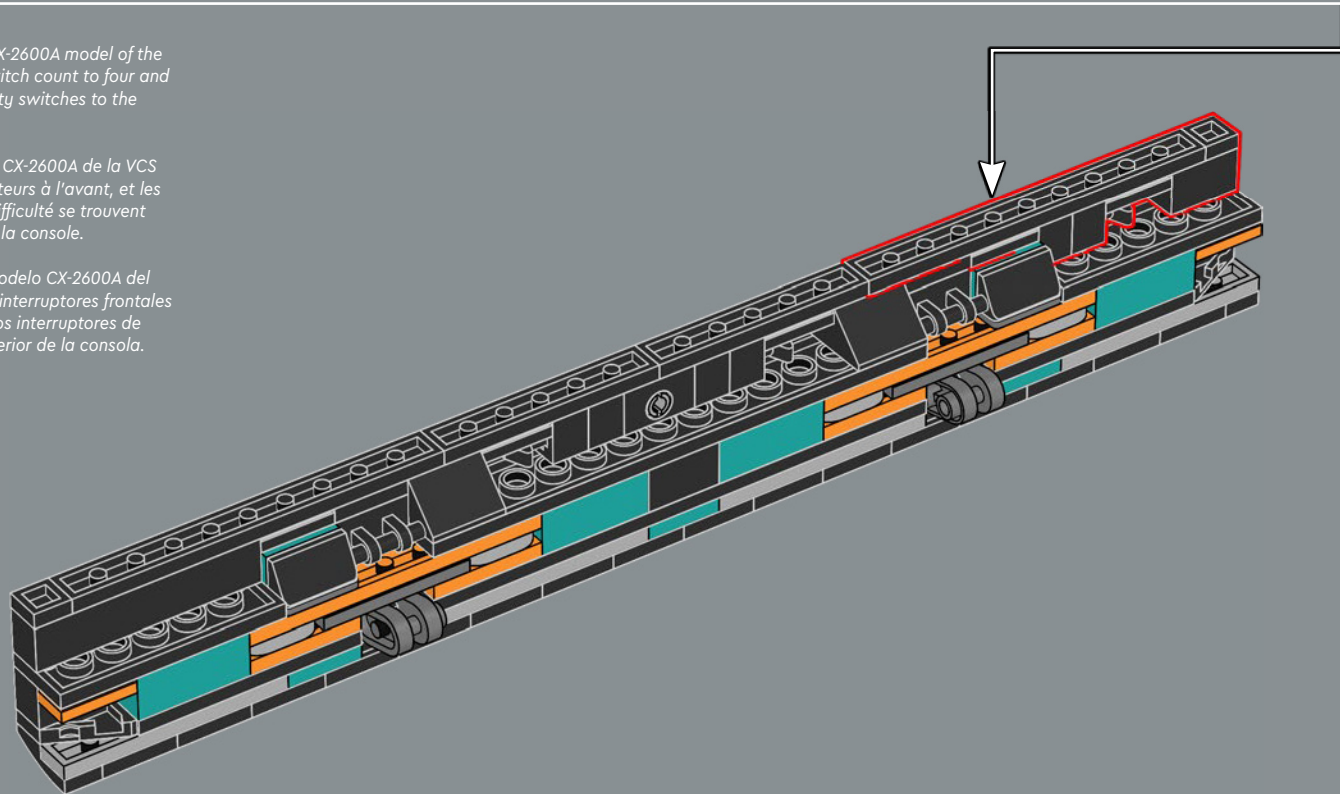

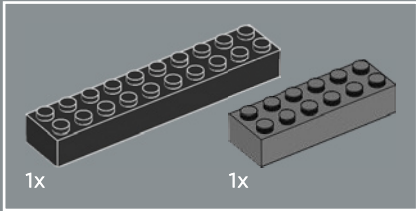
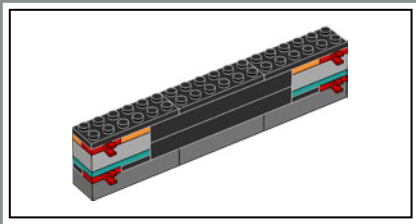

80

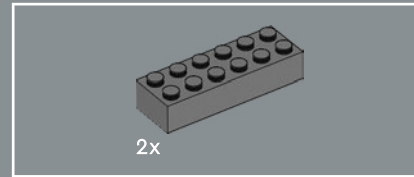
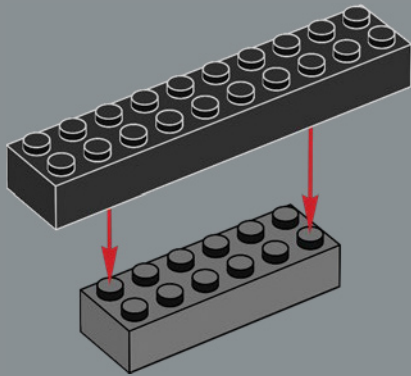

81

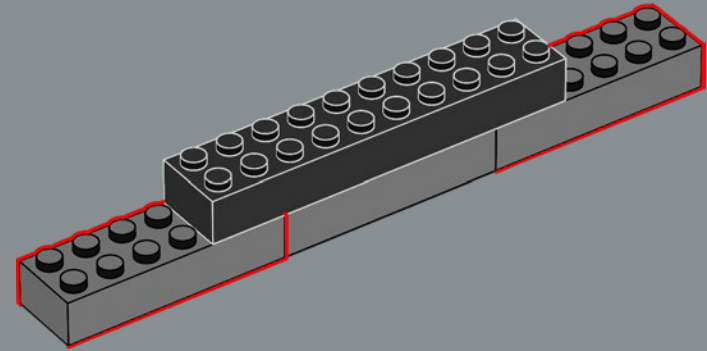

82

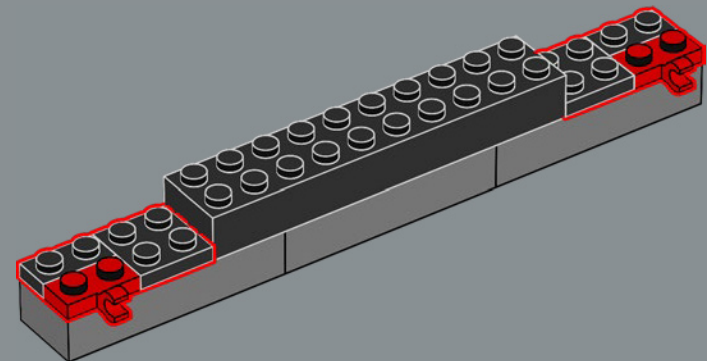

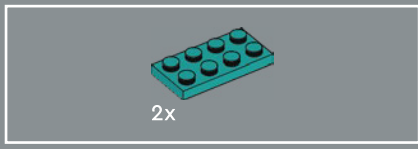

83

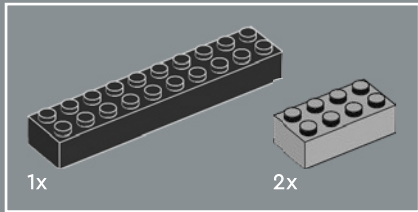
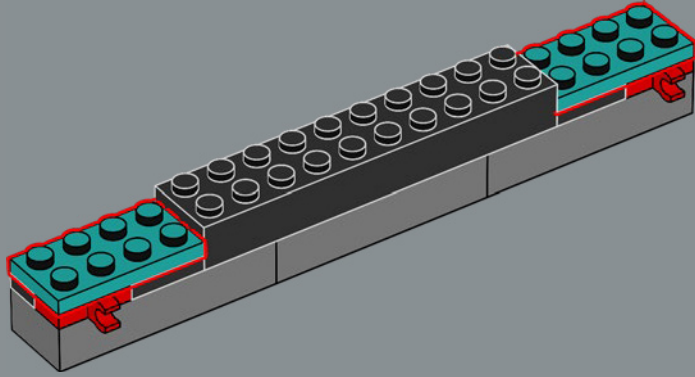

84

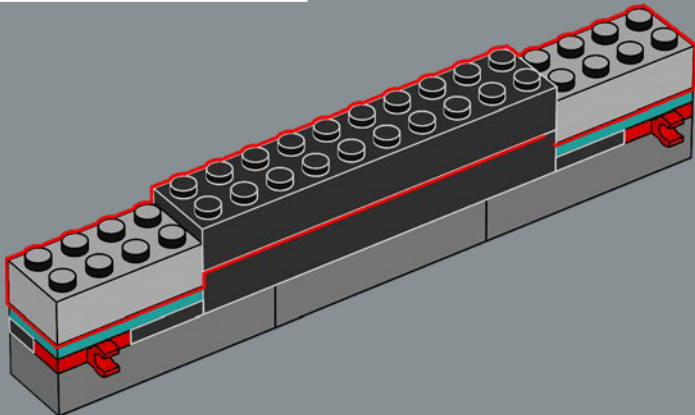

85

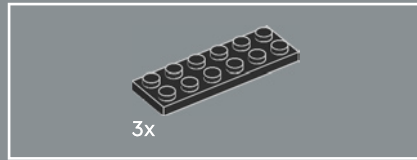
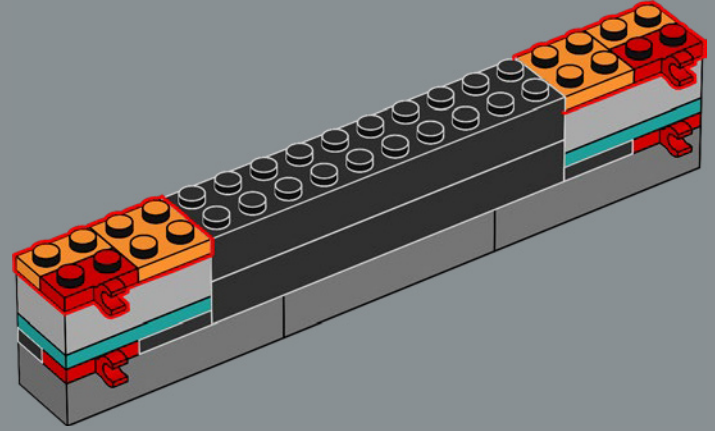

86

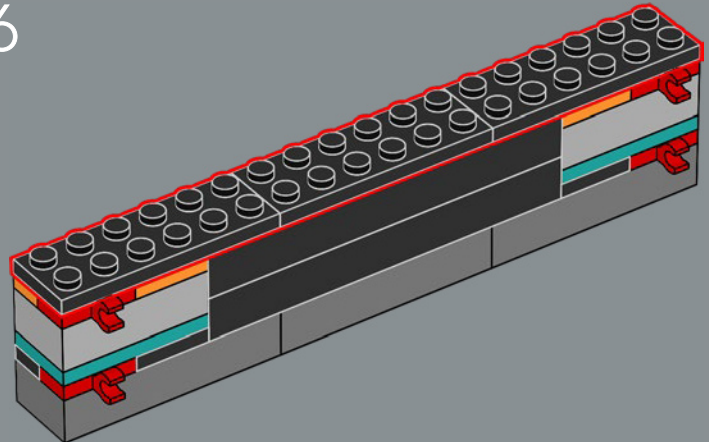

87

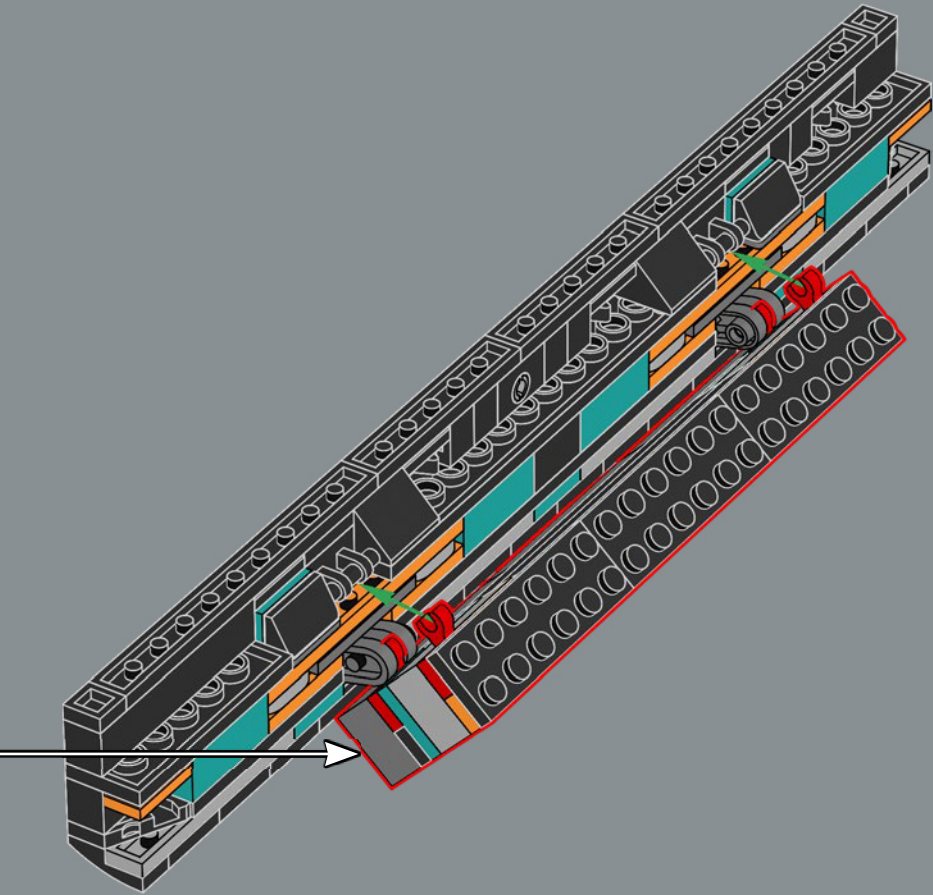

88

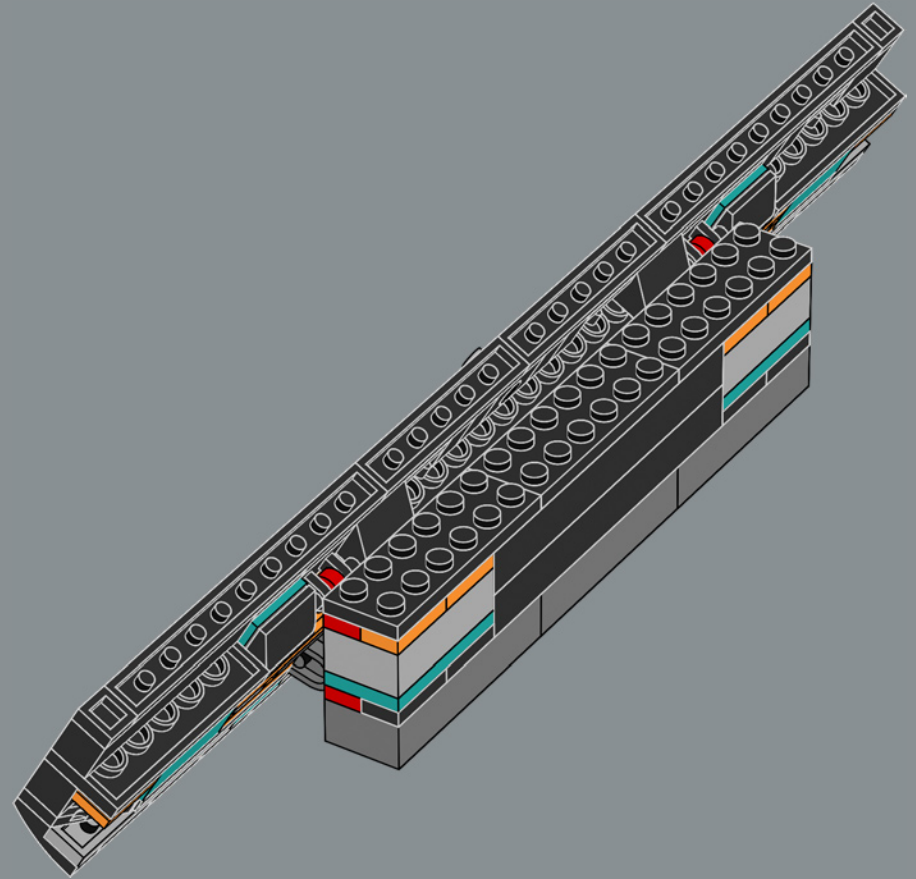

89

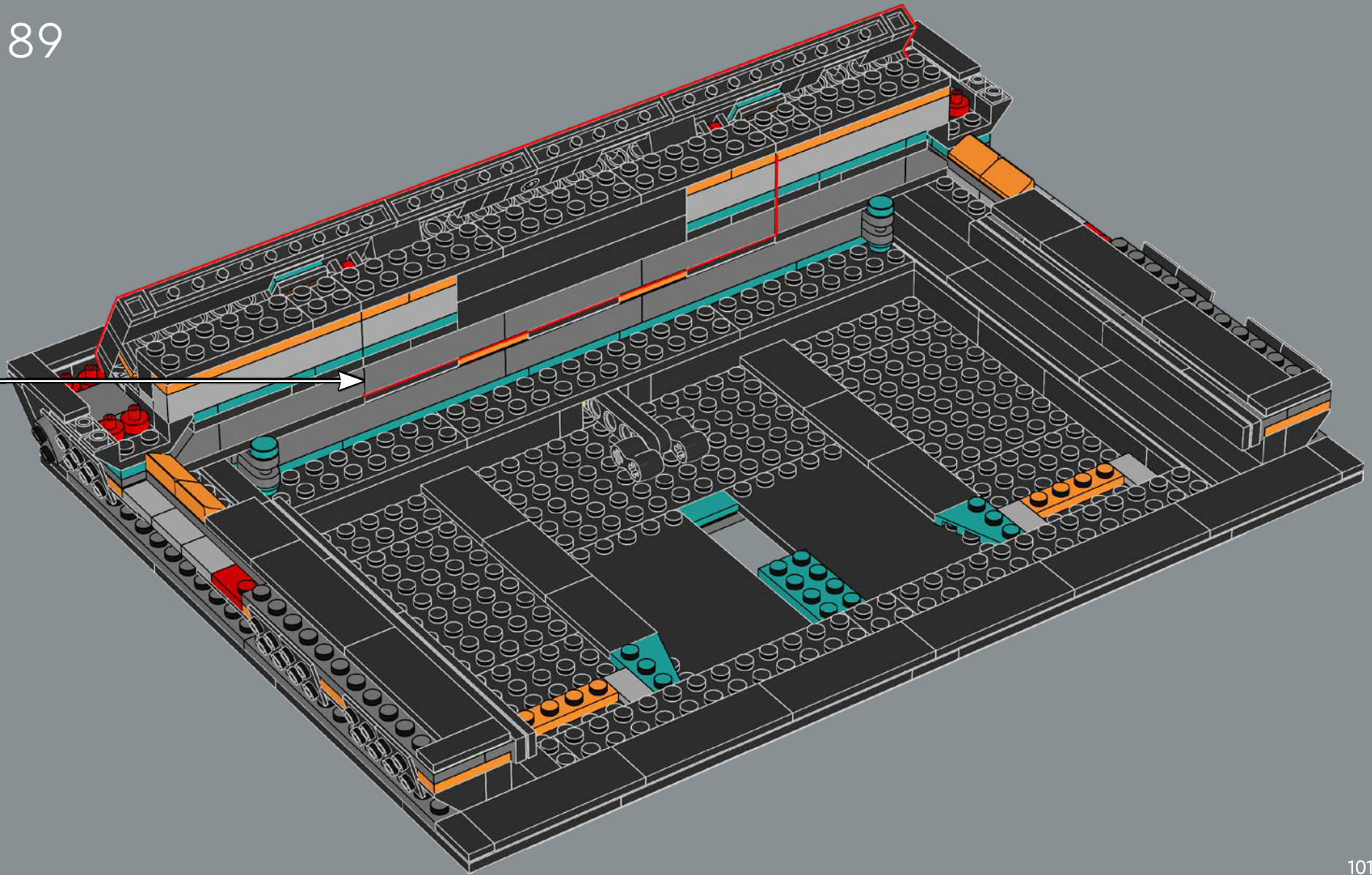



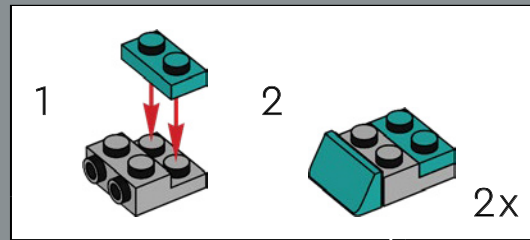
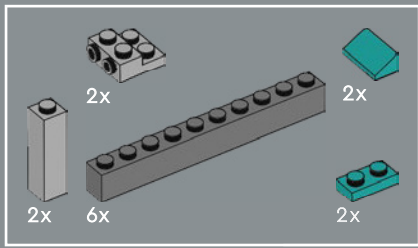

90

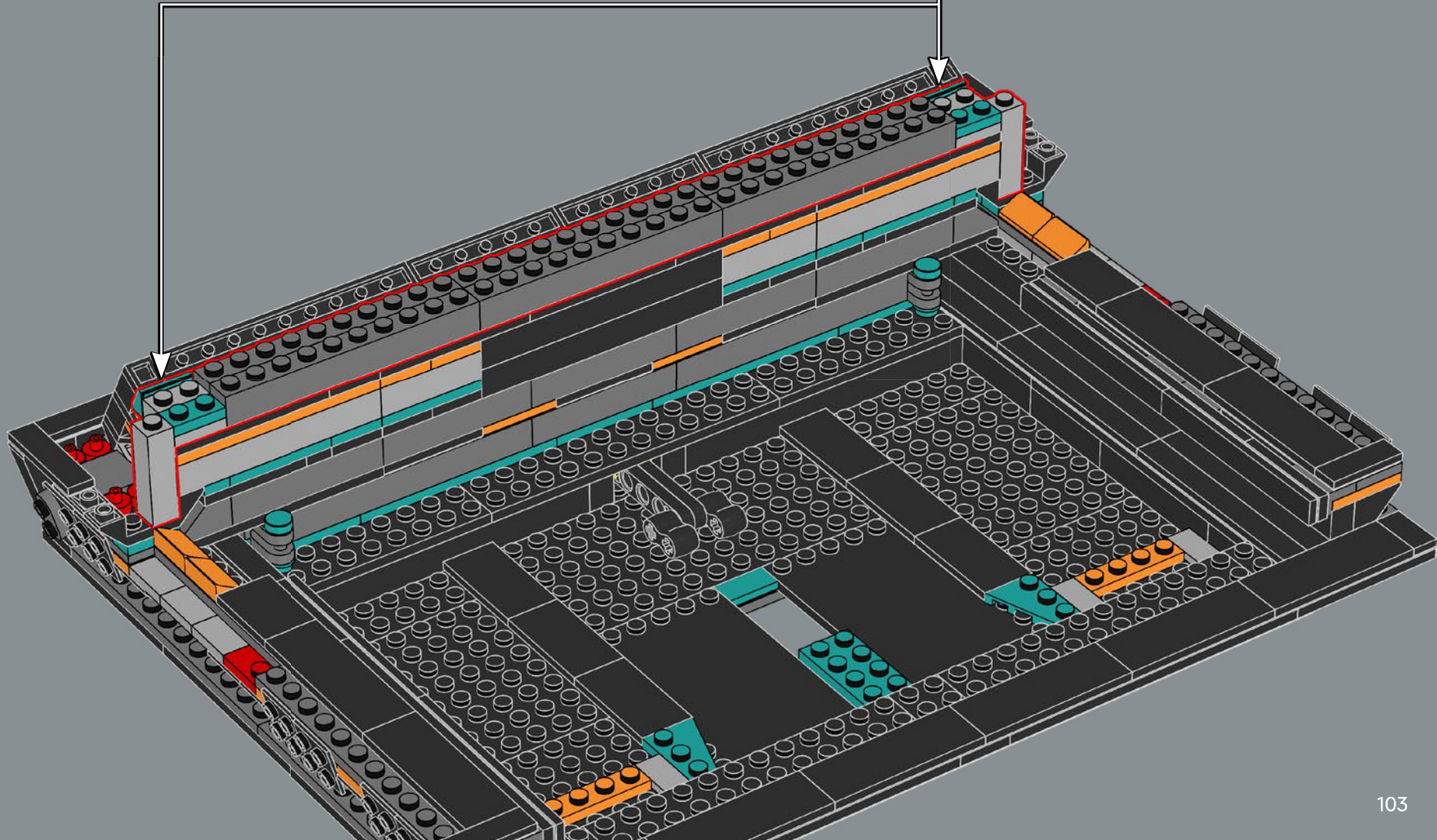

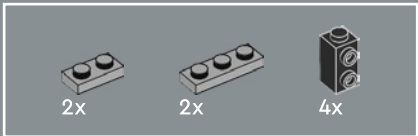

91

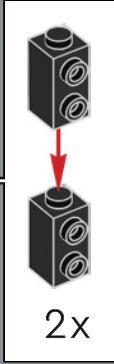
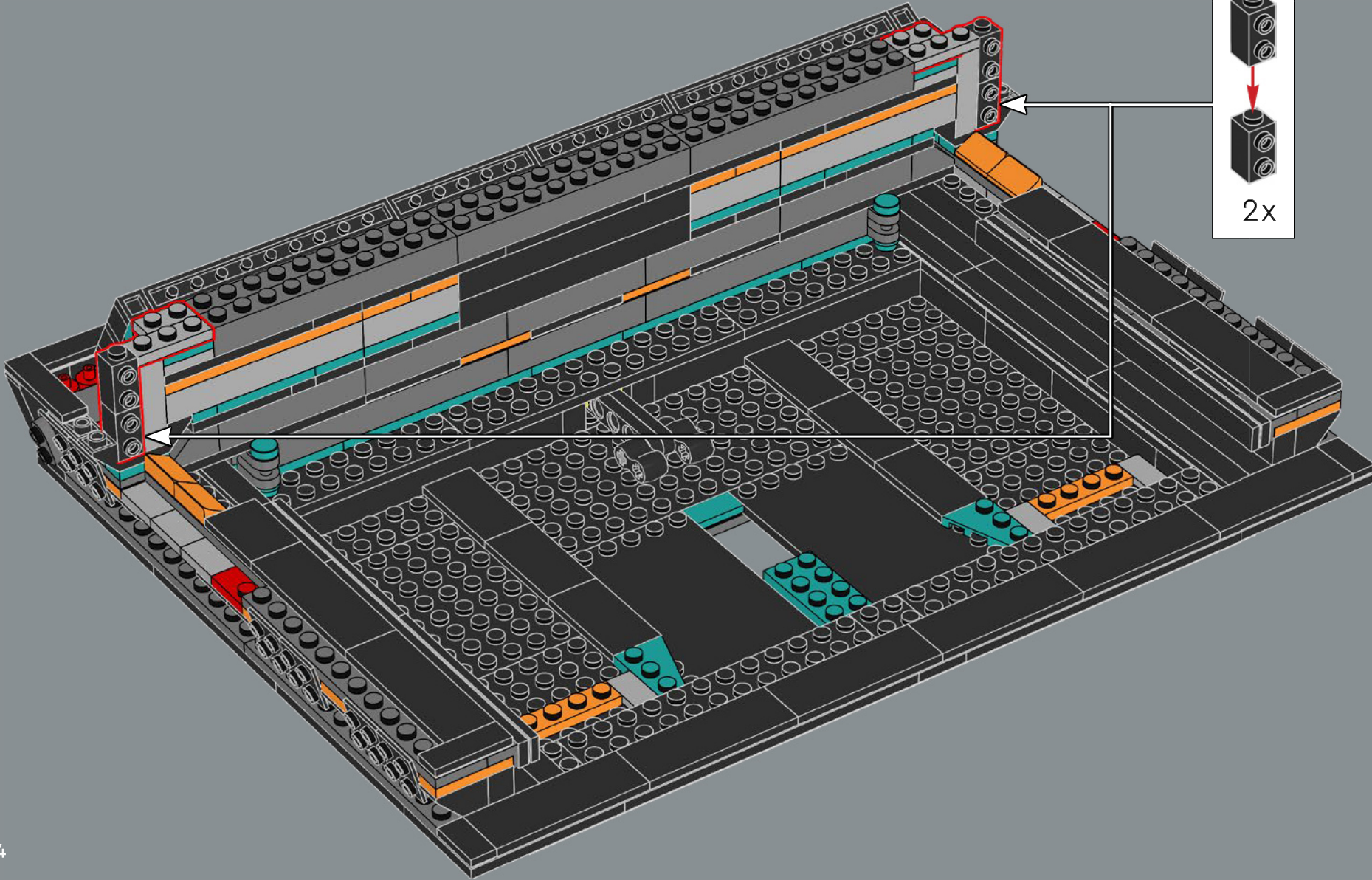

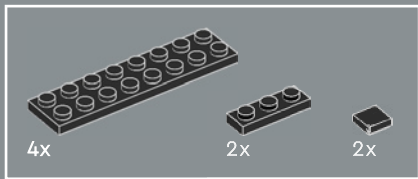

92

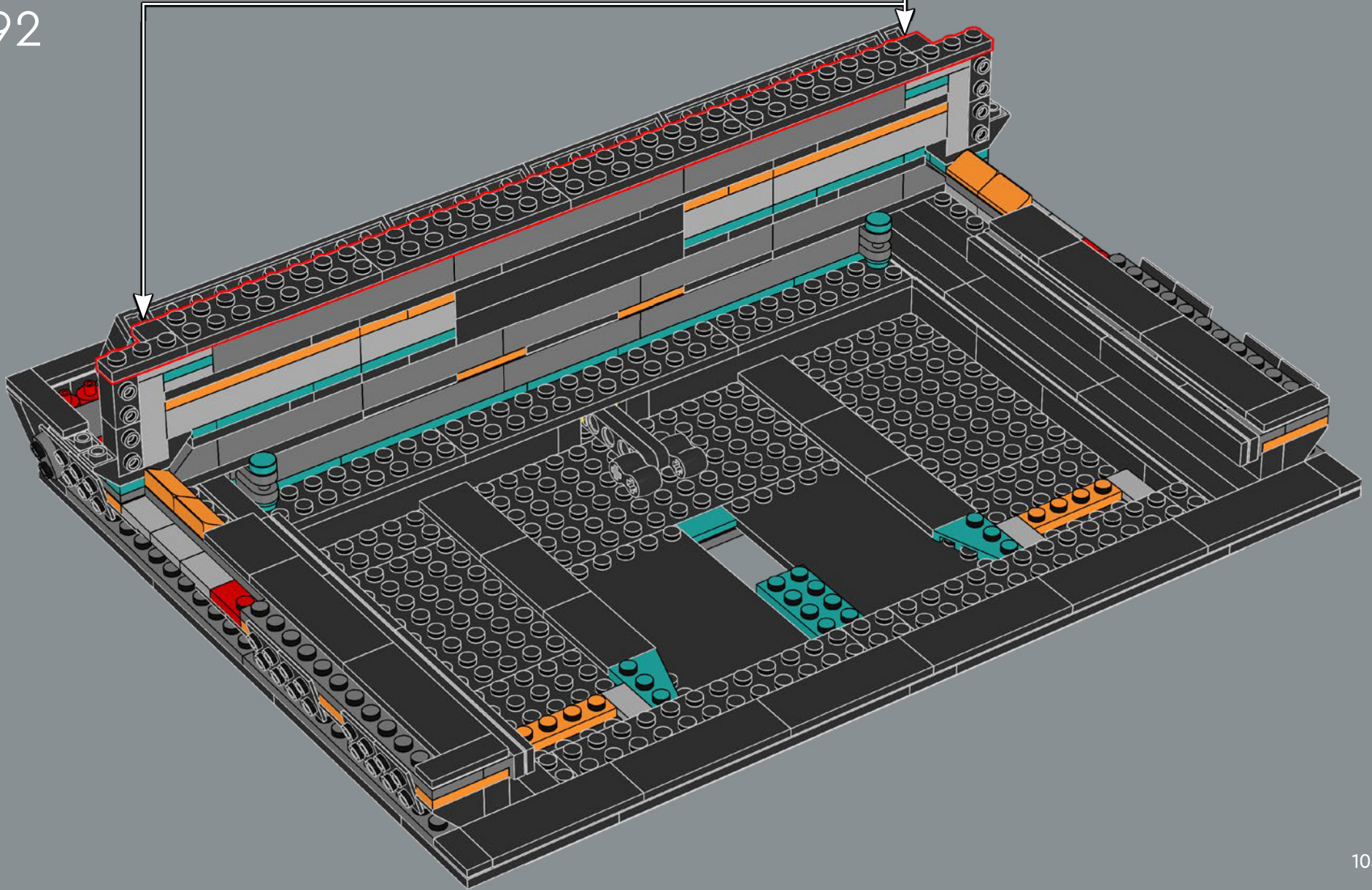

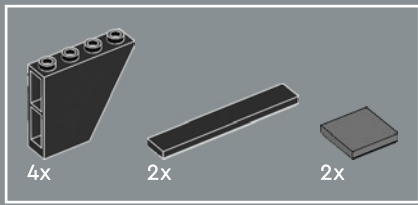

93

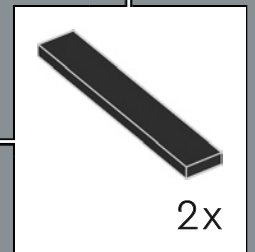
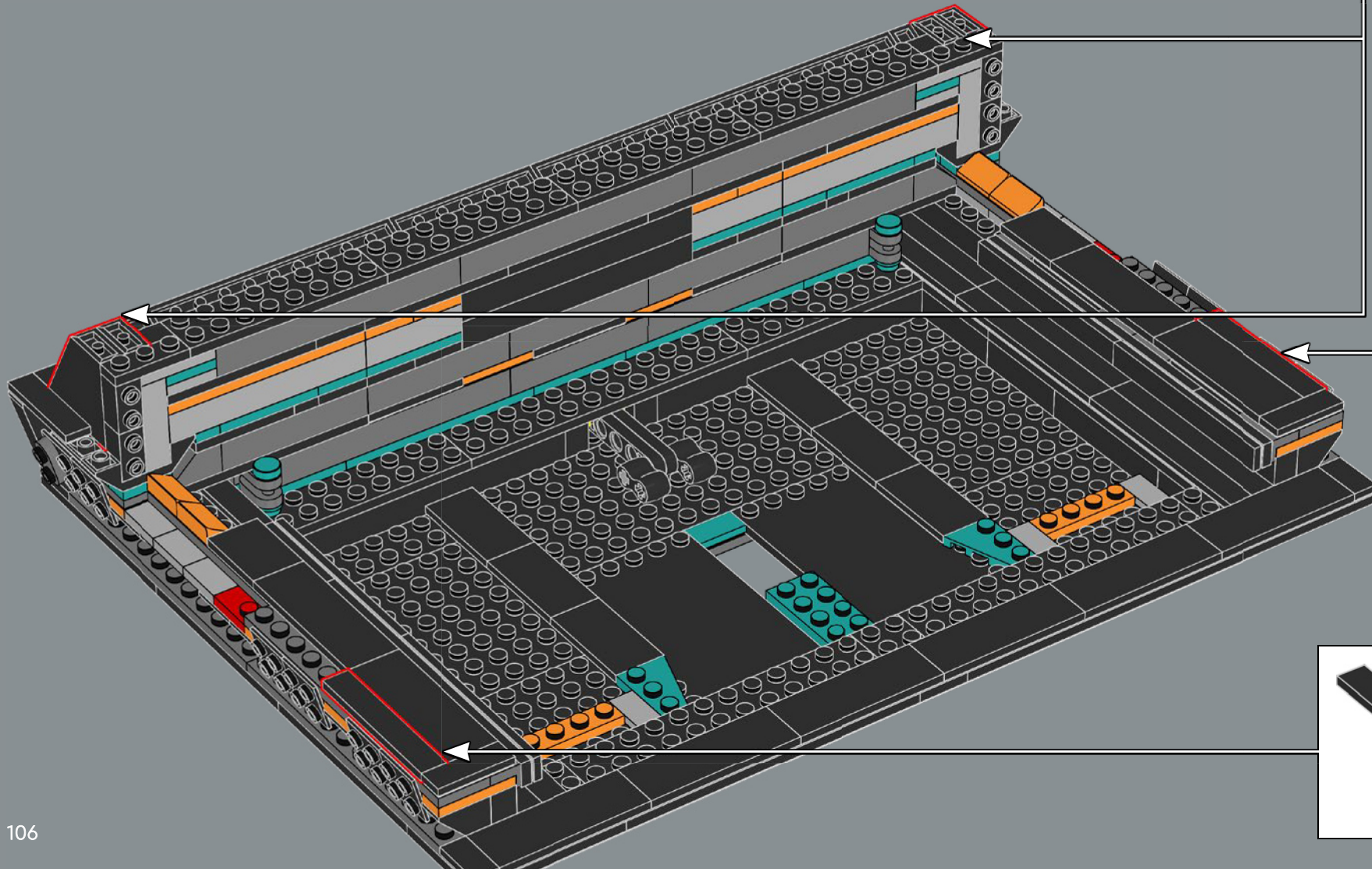
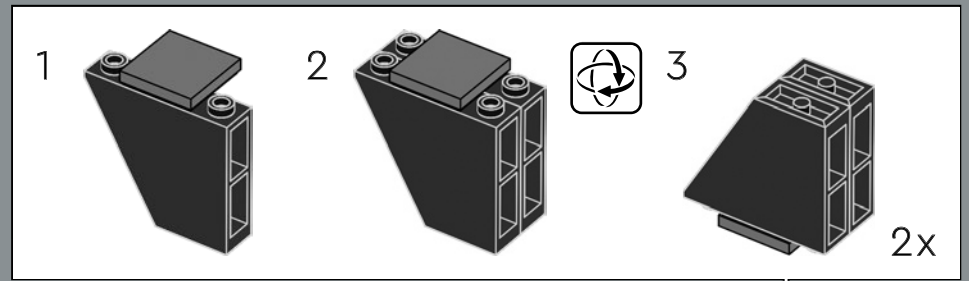

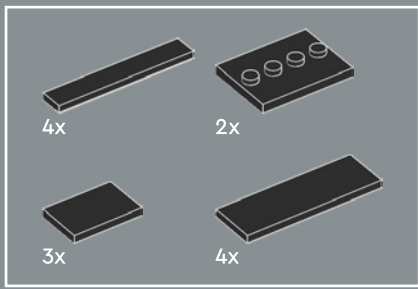

94

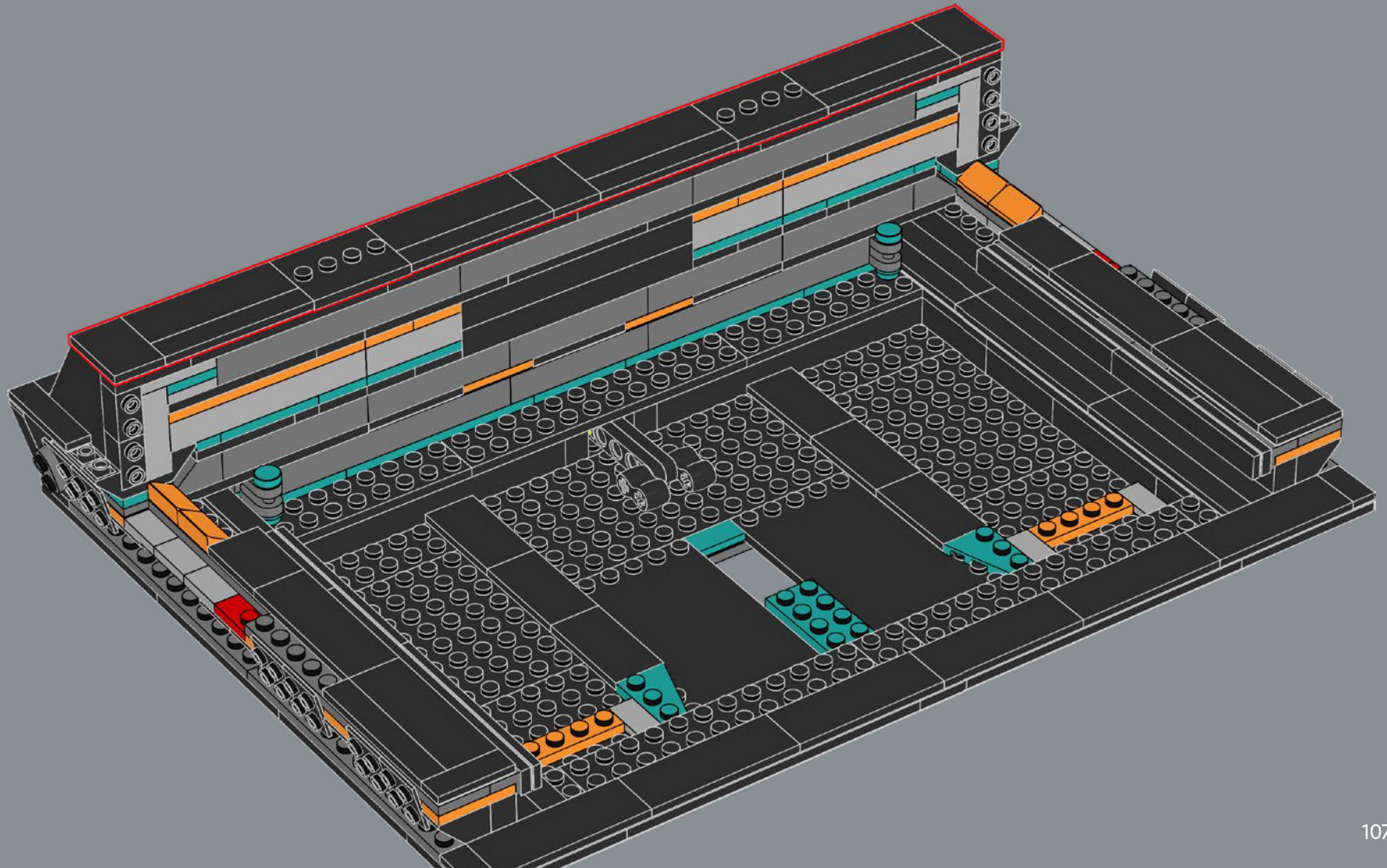

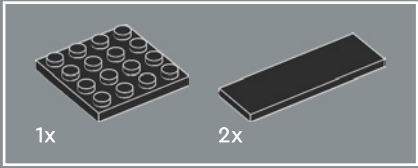
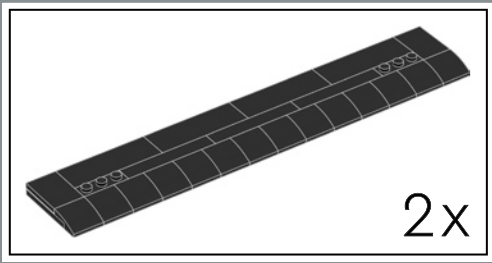

95

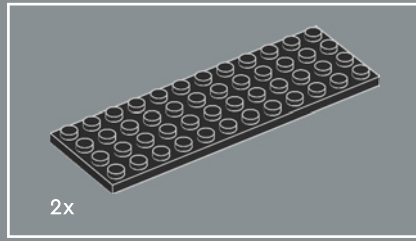
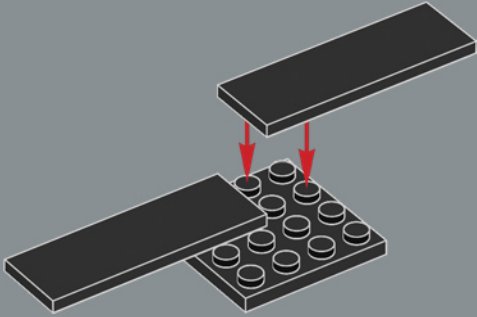

96

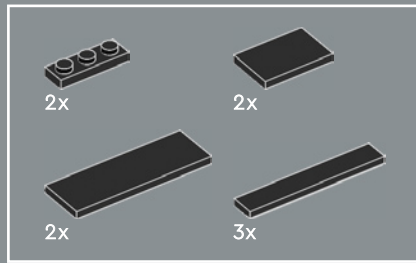
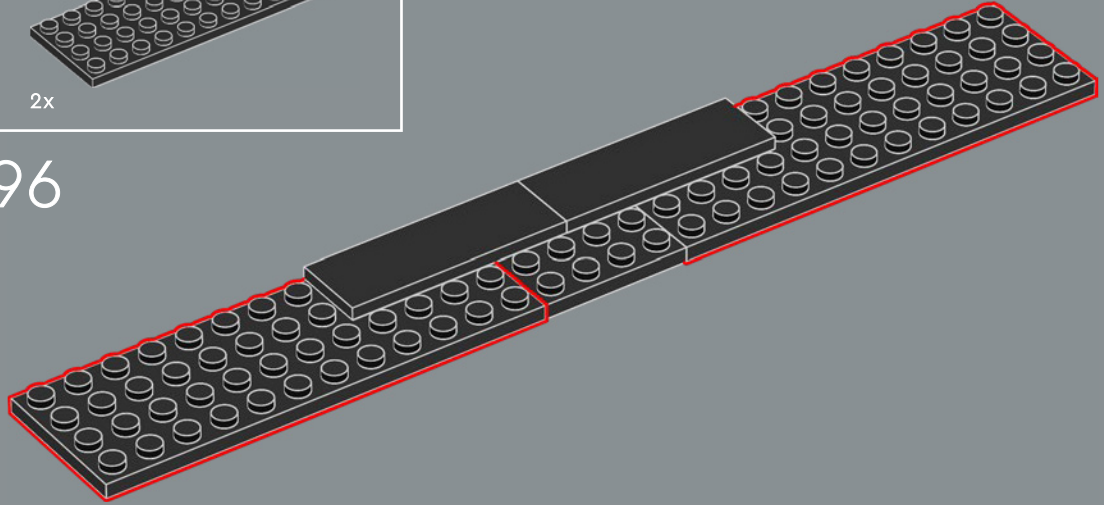

97

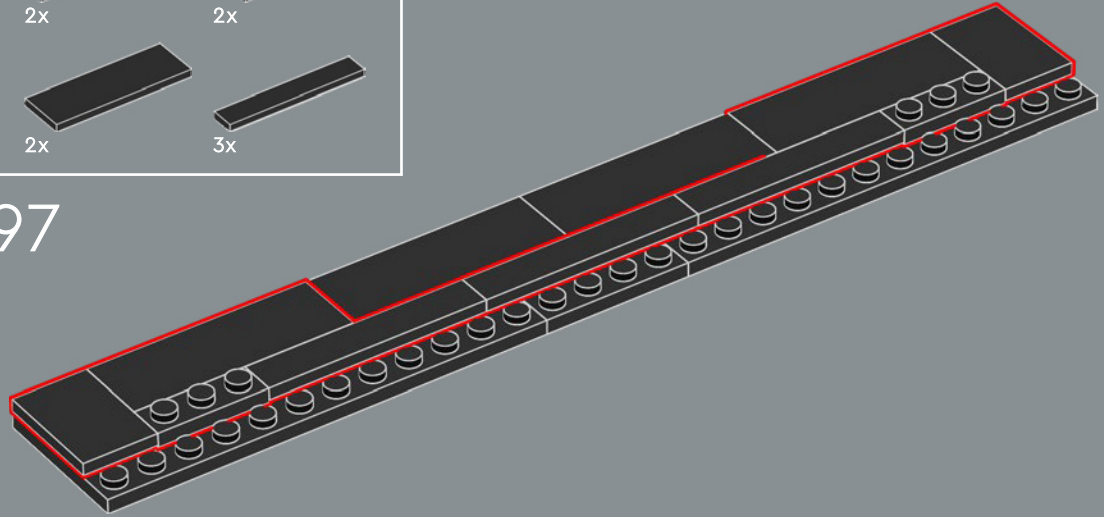



98

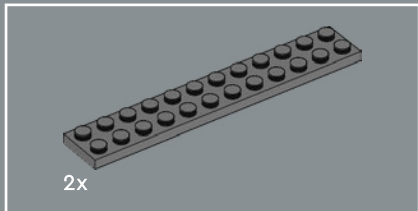
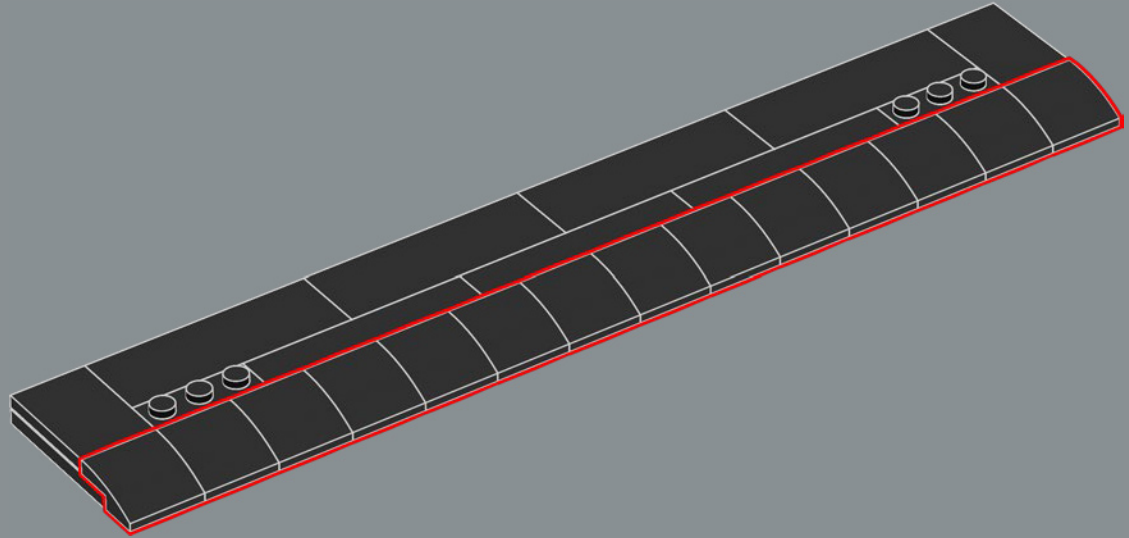

99

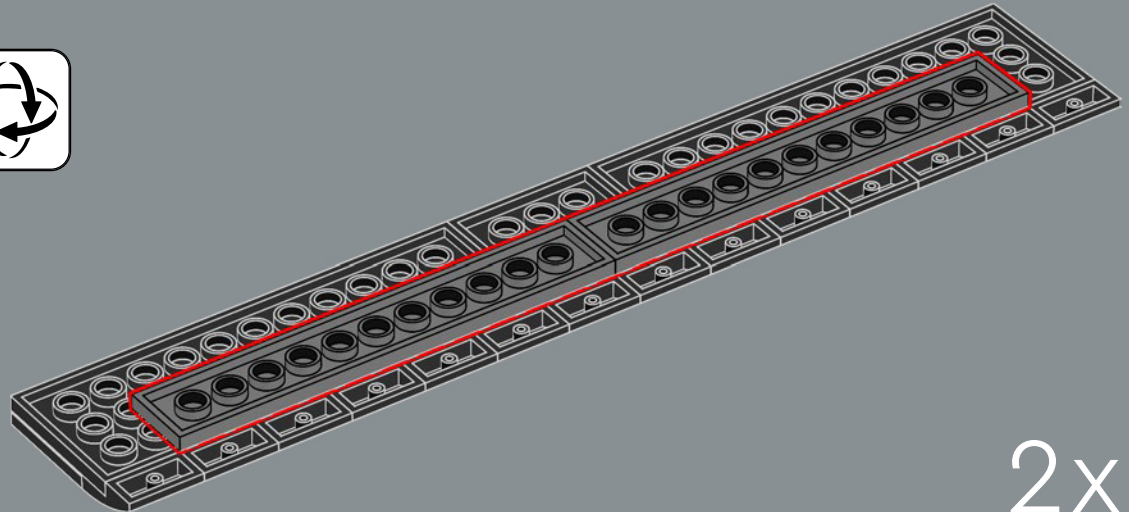

2x

100

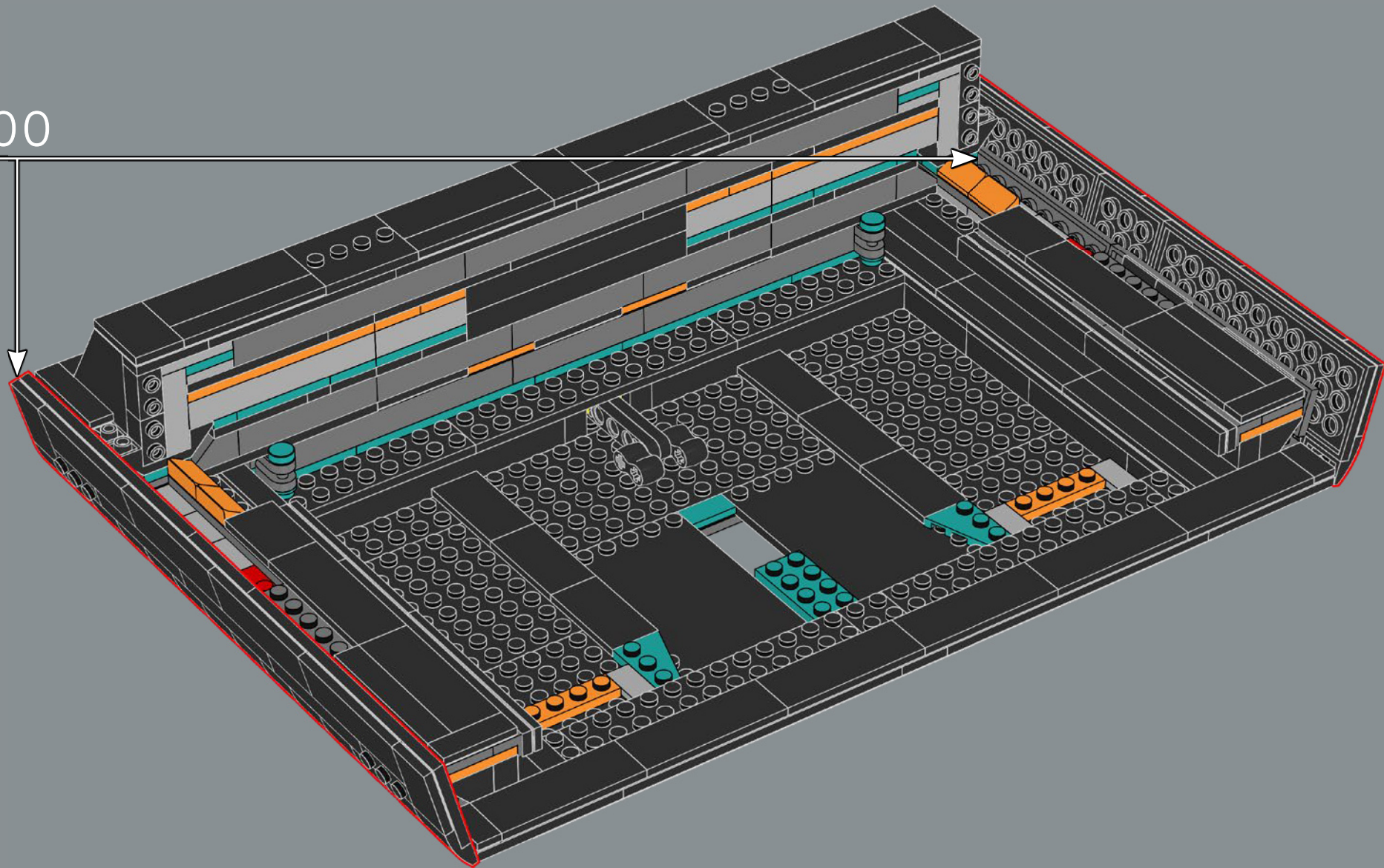

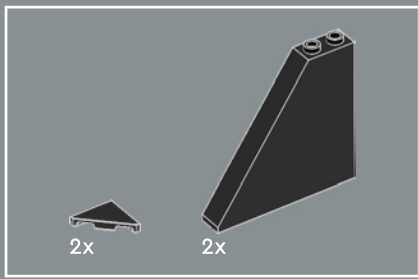

101

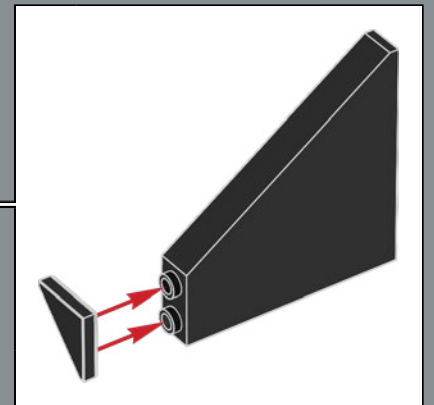
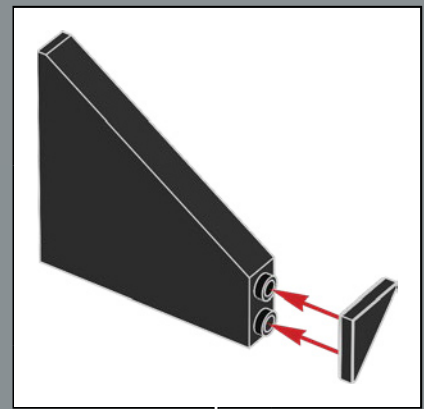
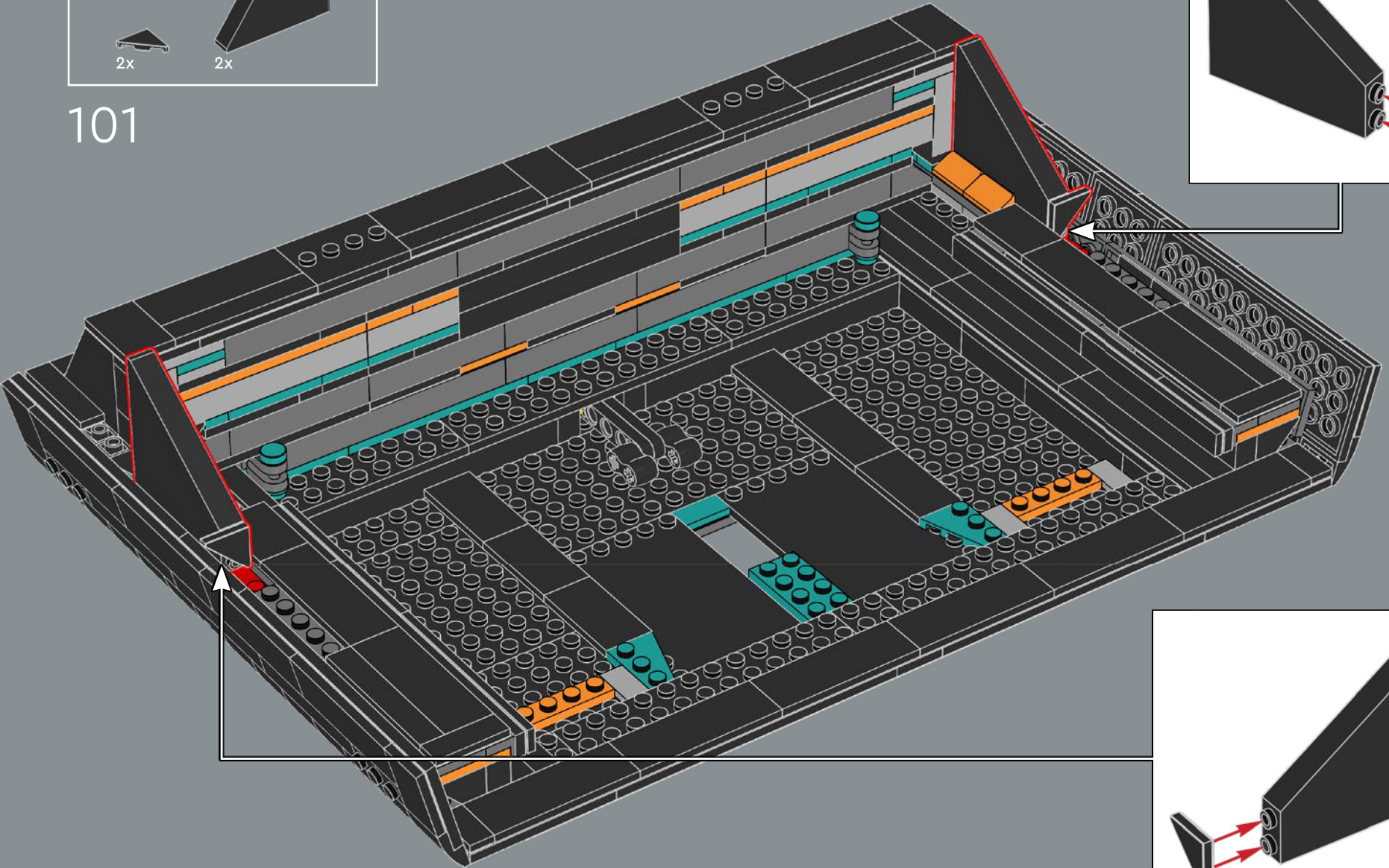

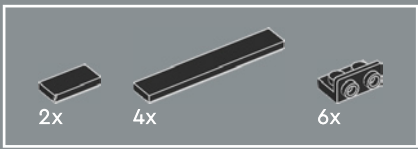

102

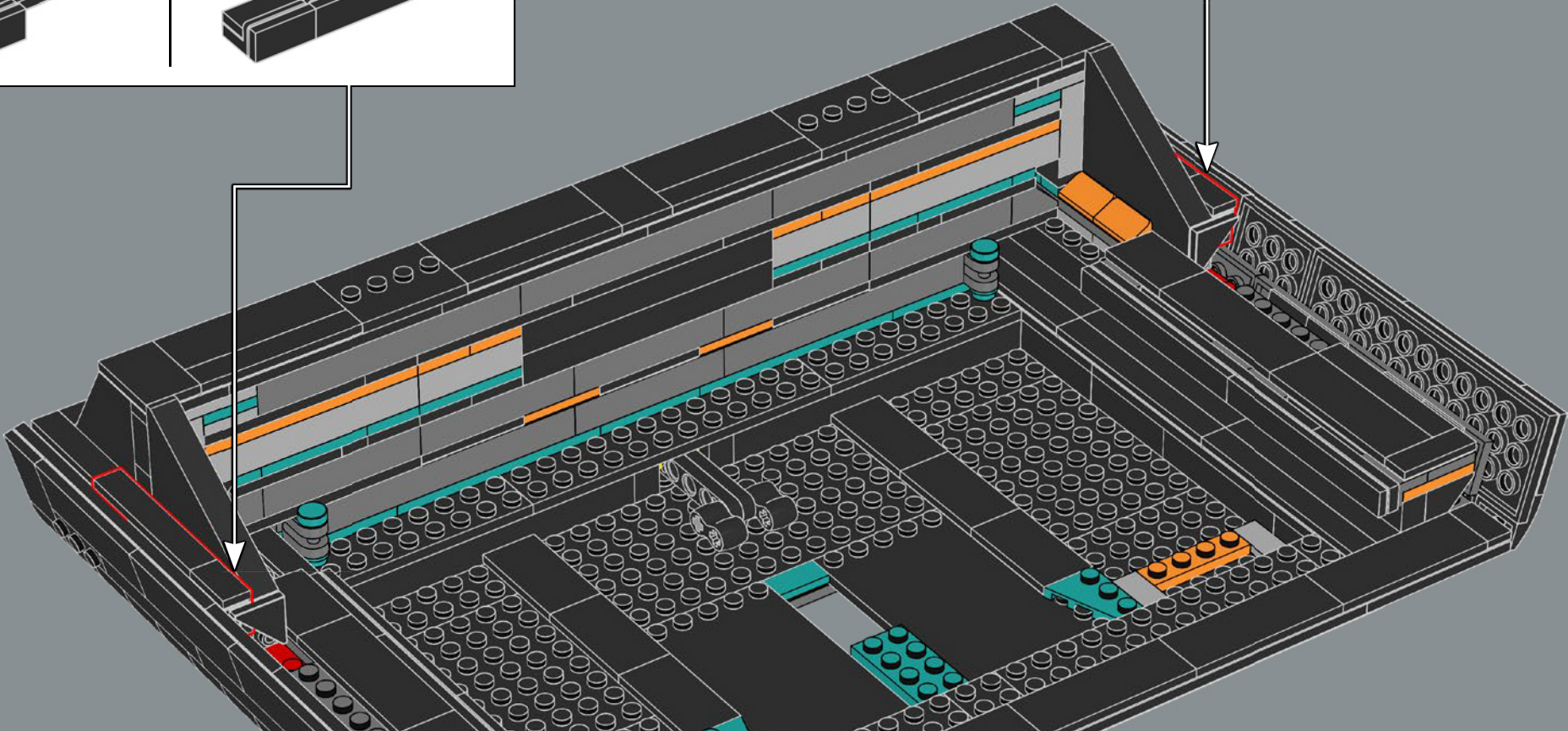
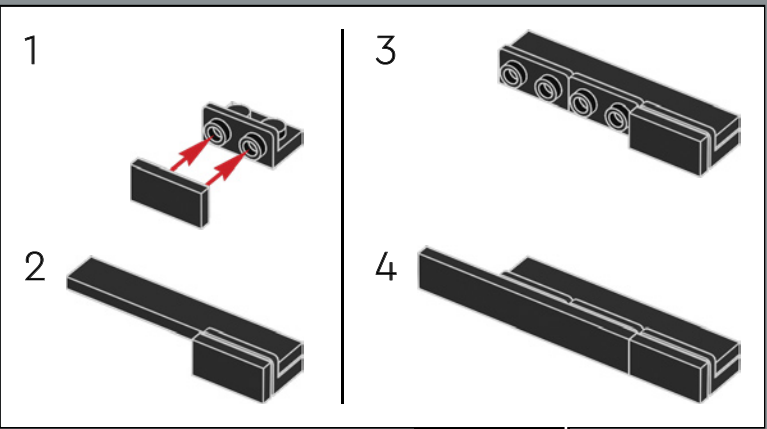
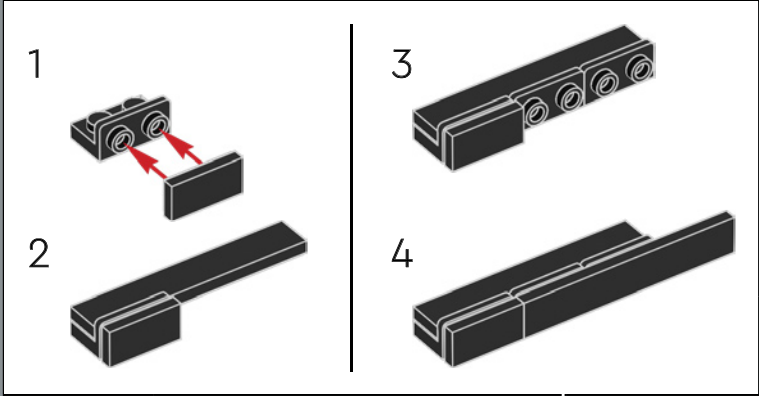

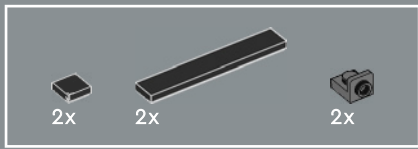

103

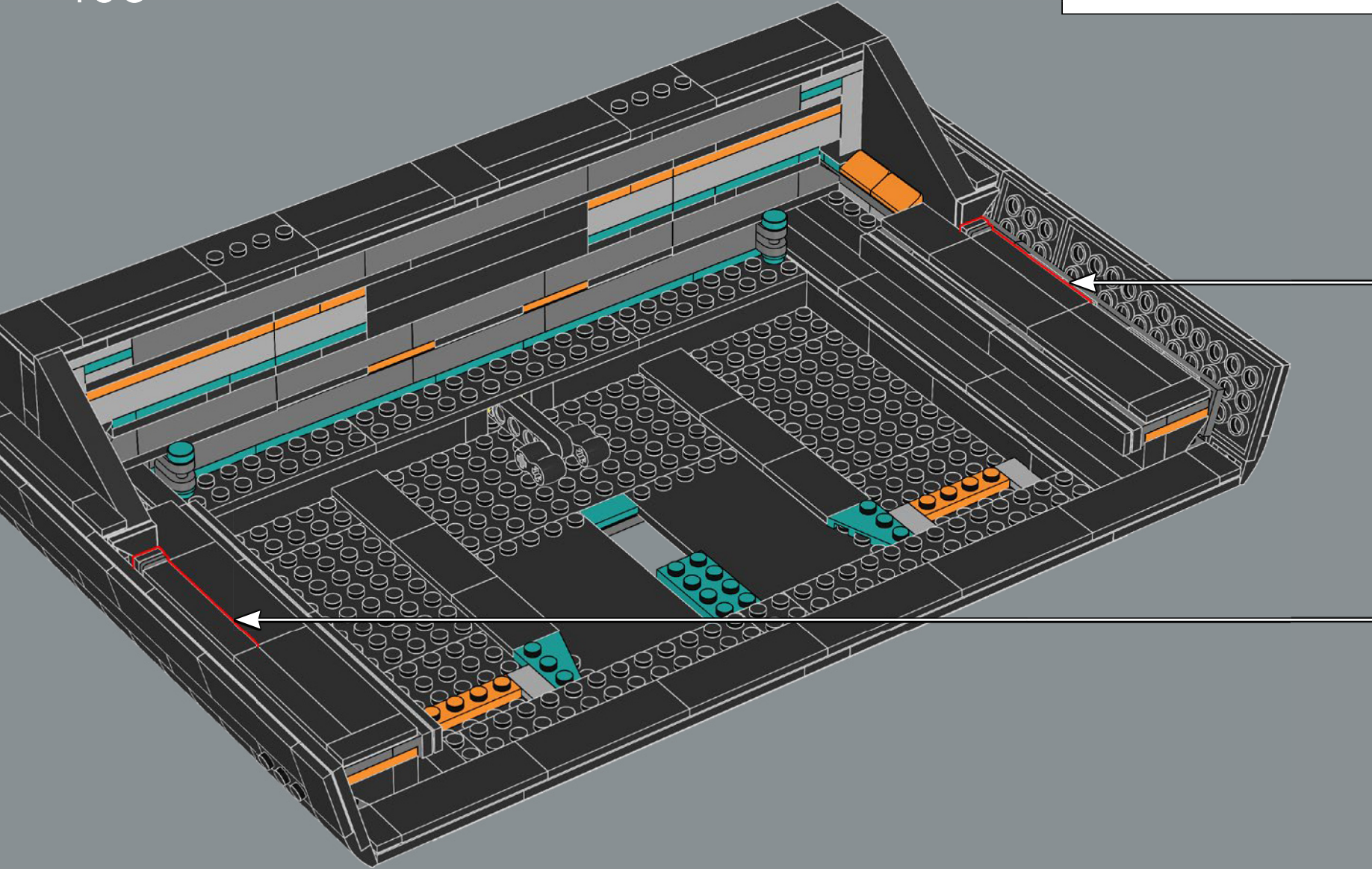
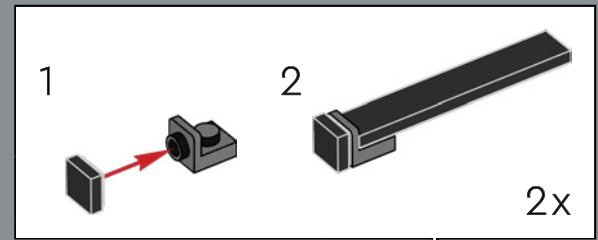

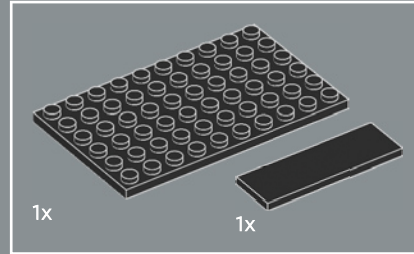
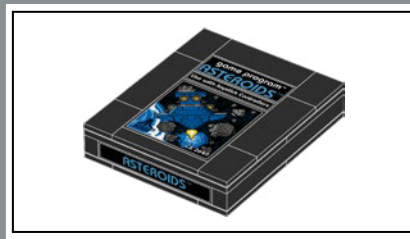

1

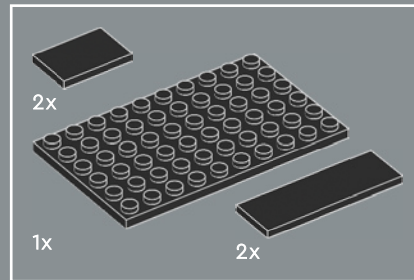
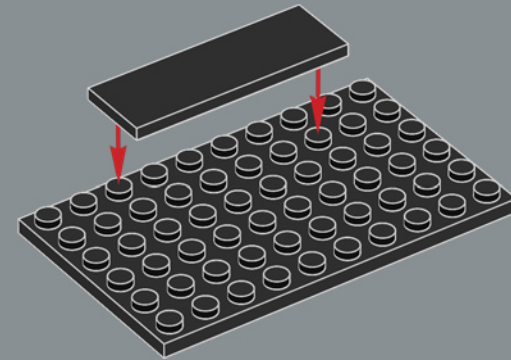

2

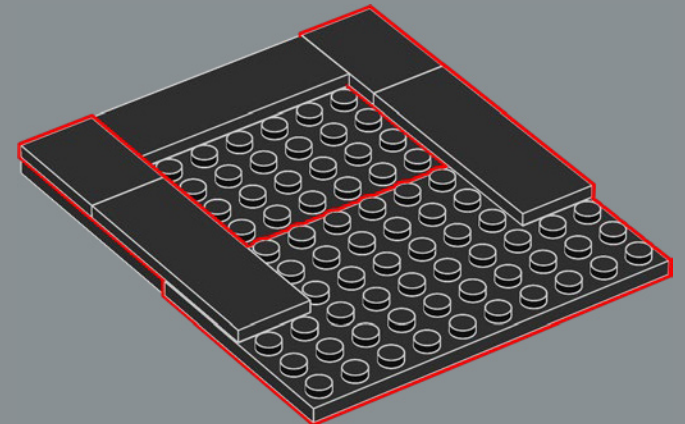

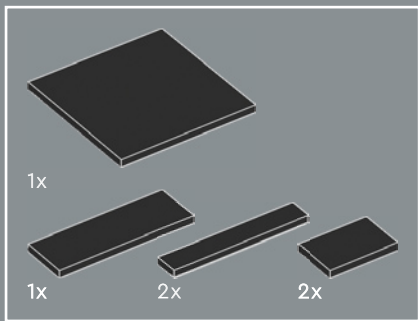

3

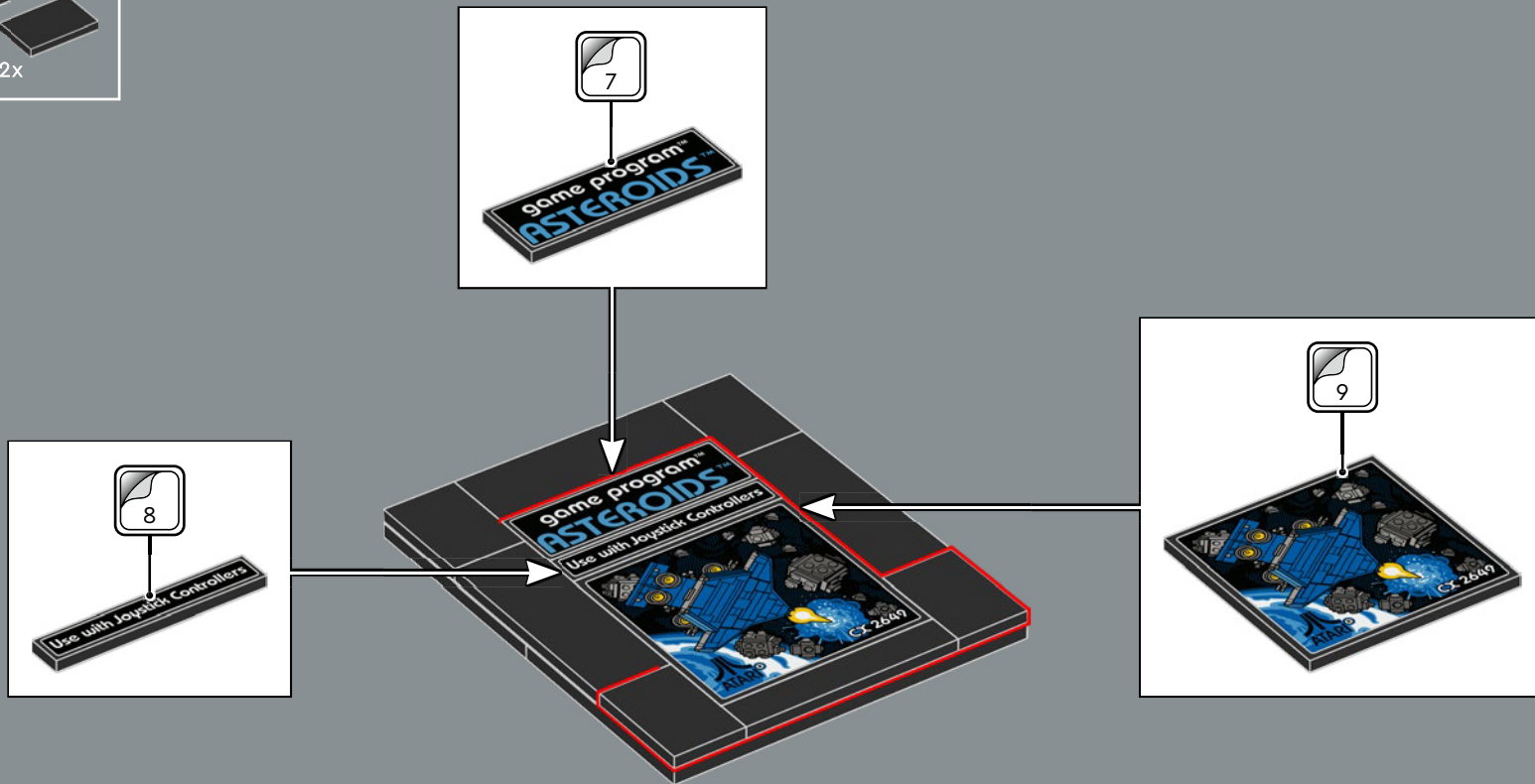

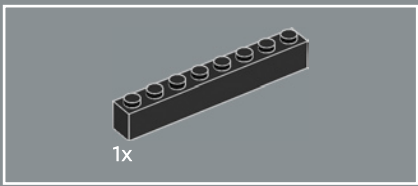

4

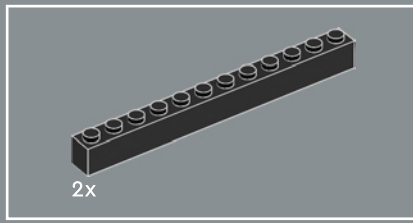
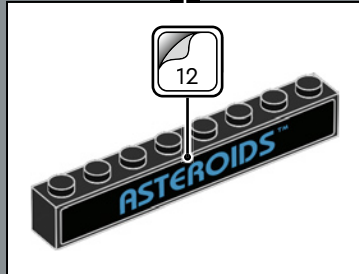
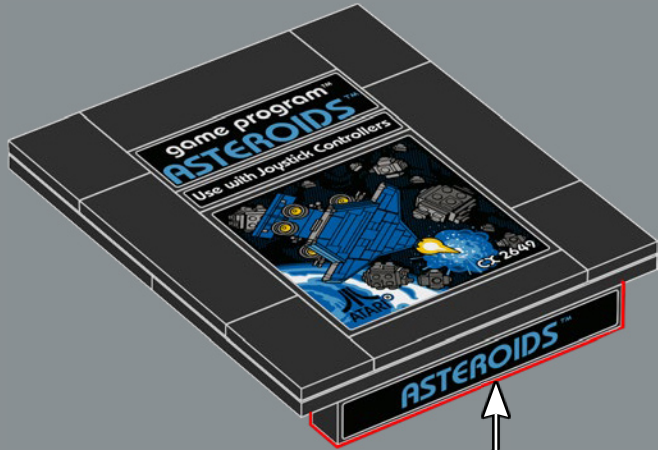

5

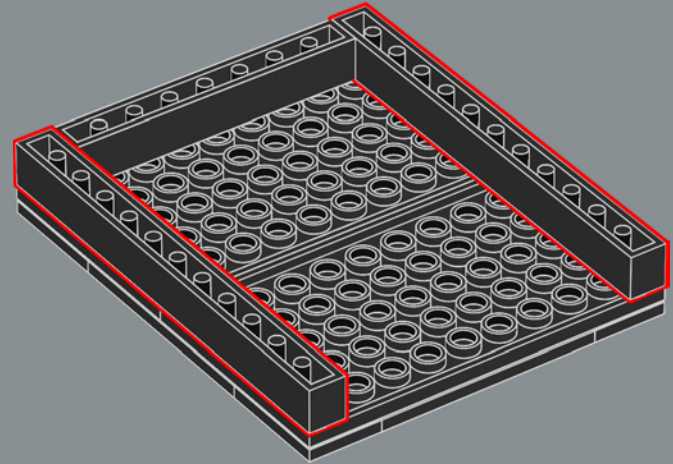

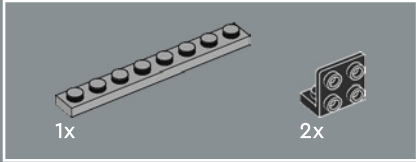
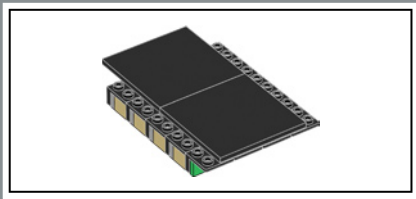

6

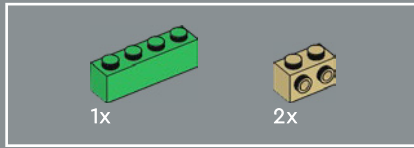
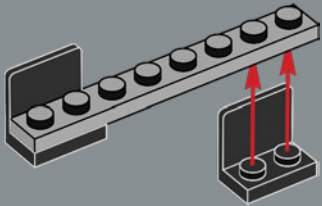

7

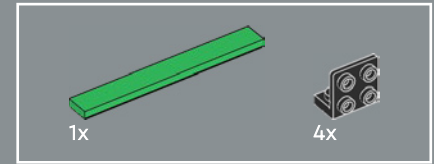
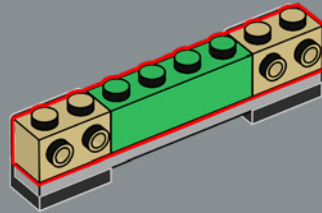

8

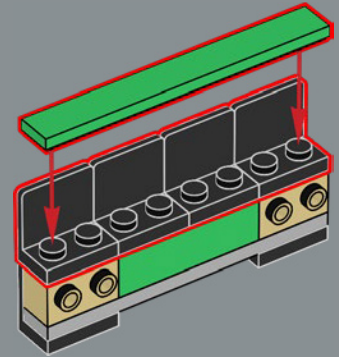

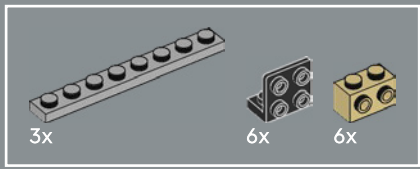

9

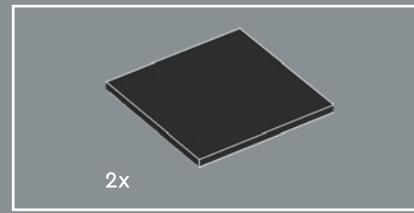
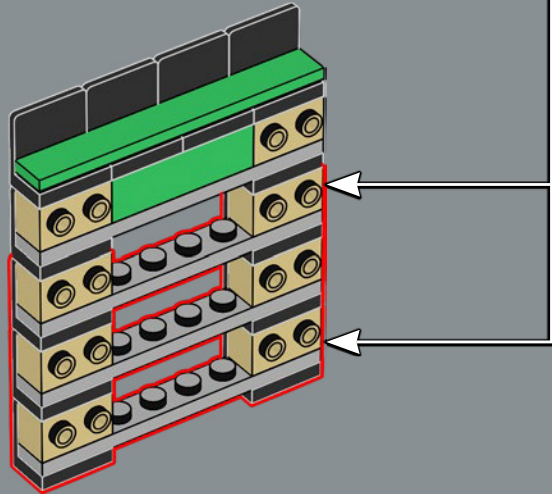
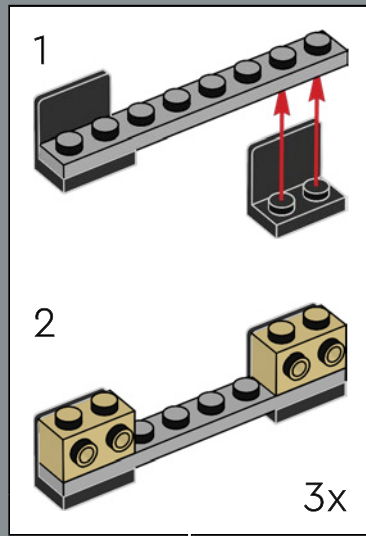

10

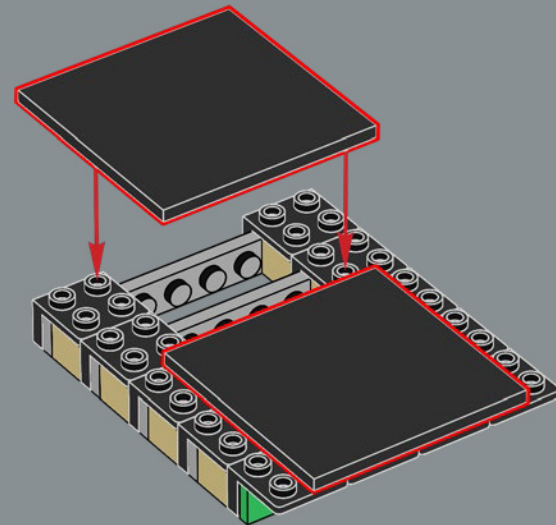

11

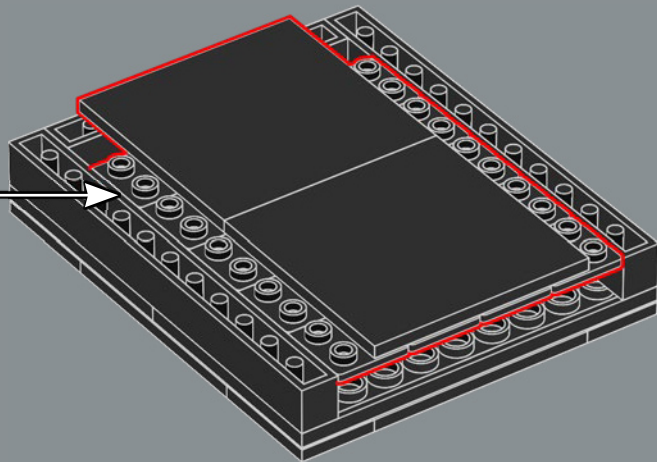

All cartridge artwork has been abstracted to include LEGO® elements, but the Asteroids artwork is particularly special because it features the new LEGO 10497 Galaxy Explorer.

Les illustrations des cartouches contiennent toutes des éléments LEGO®, et celle d'Asteroids présente le nouvel ensemble LEGO 10497 Explorateur galactique.

Todas las carátulas de los cartuchos se han abstraído para incluir elementos LEGO®, pero la de Asteroids es particularmente especial porque incluye el nuevo set LEGO Galaxy Explorer (10497).



12

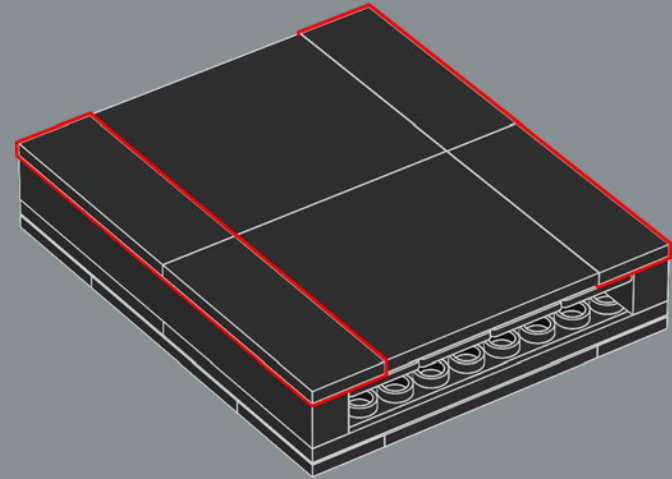
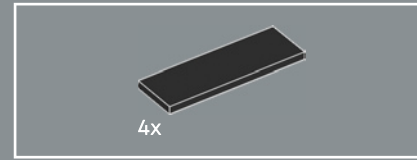

13



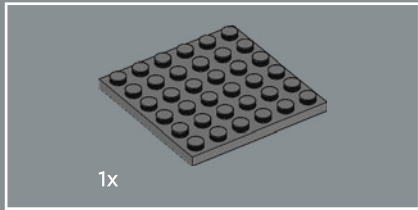
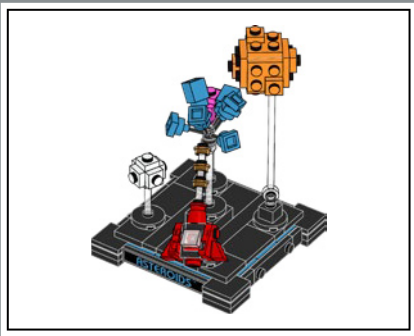

1

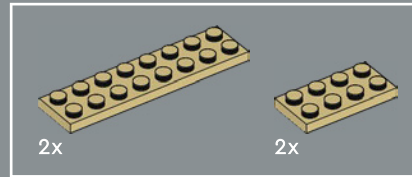
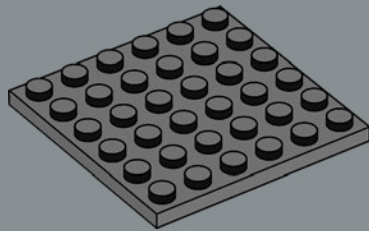

2

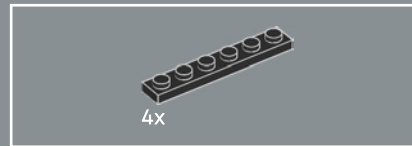
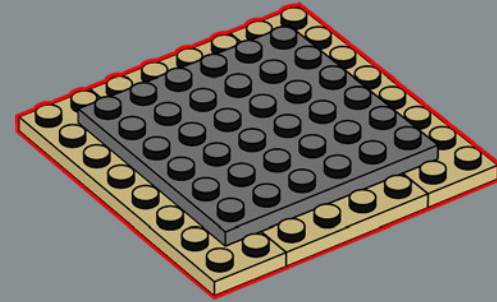

3

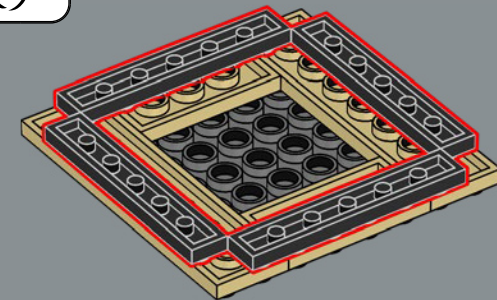

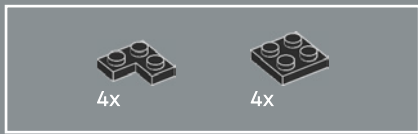

4

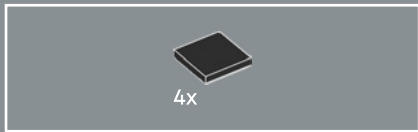
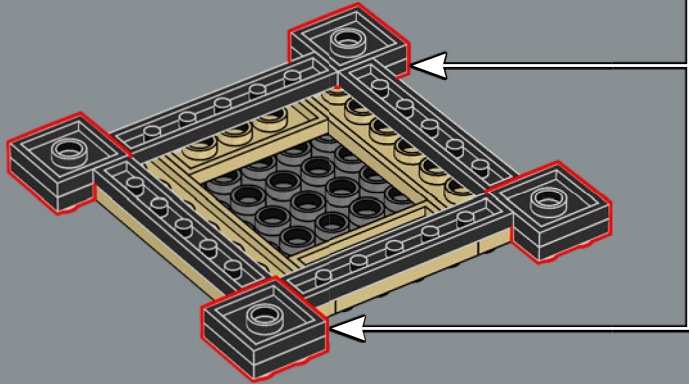
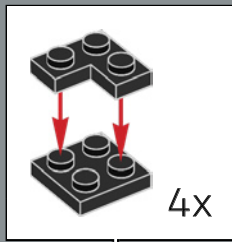

5

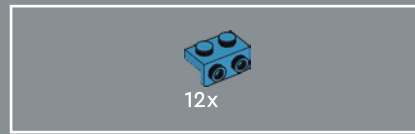
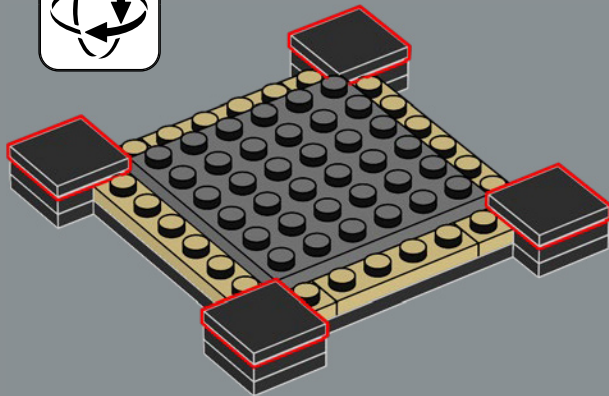

6

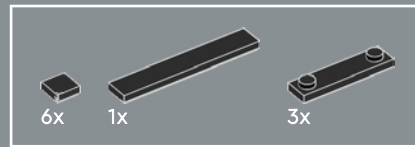
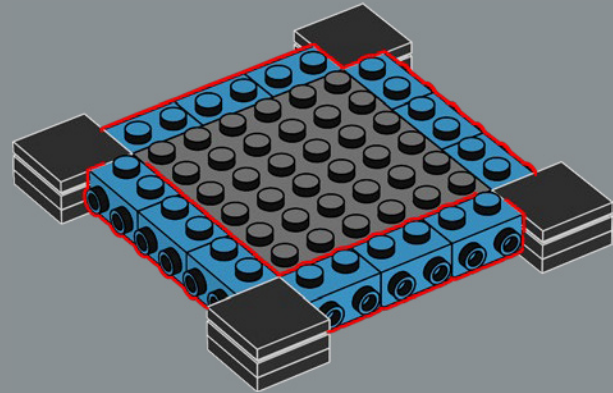

7

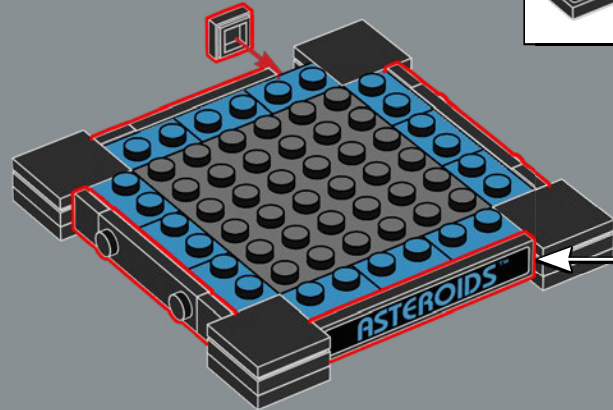
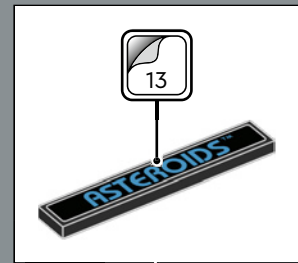

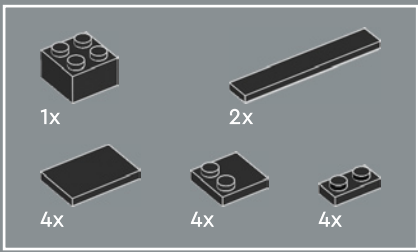

8

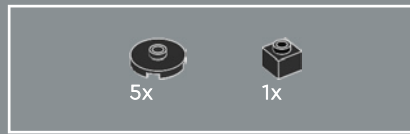
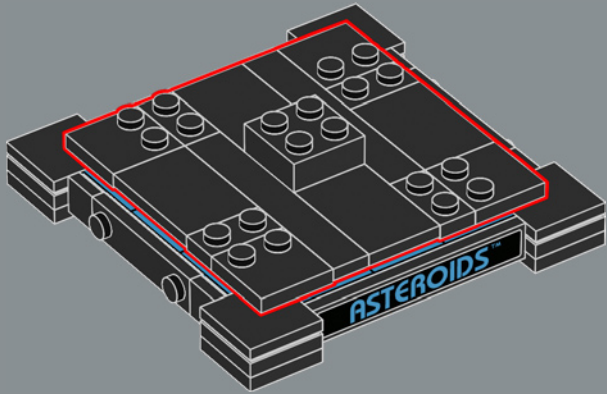

9

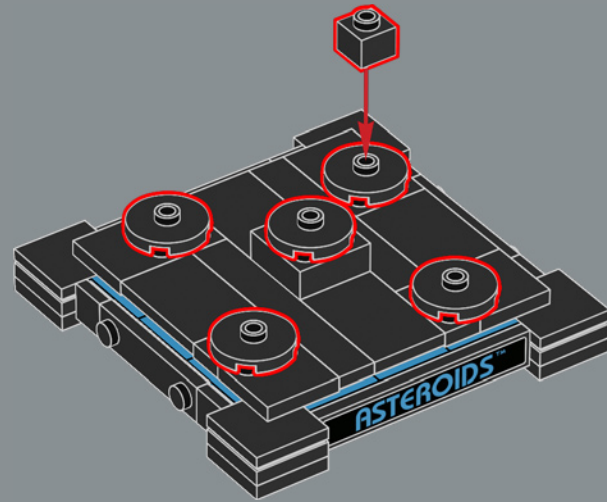

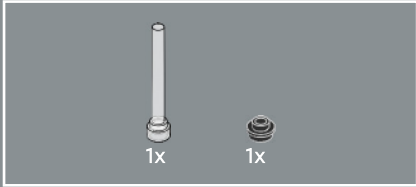
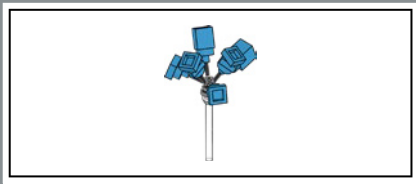

10



11

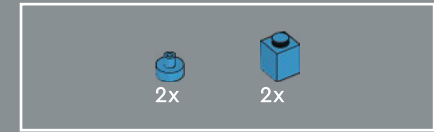
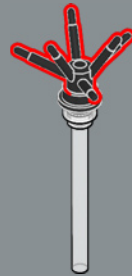

12

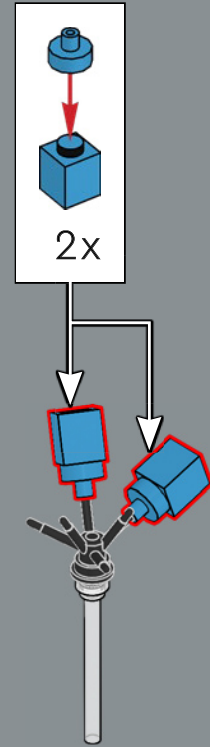

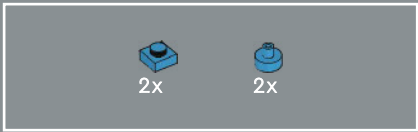

13

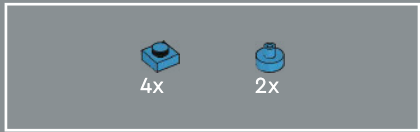
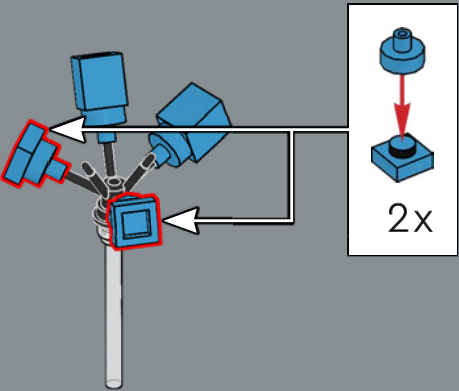

14

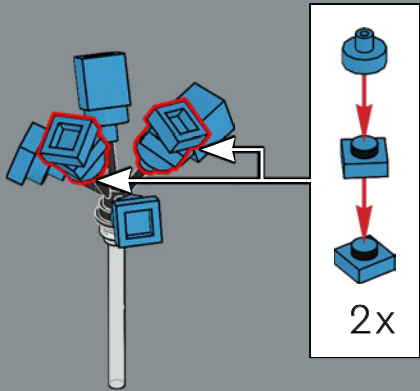

15

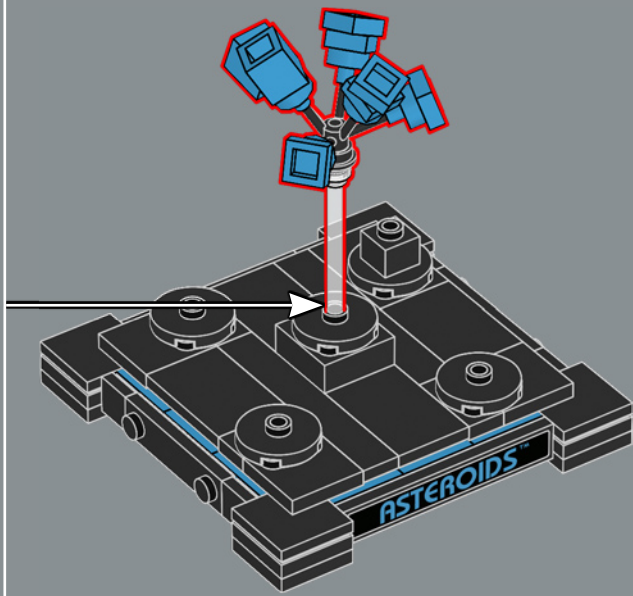

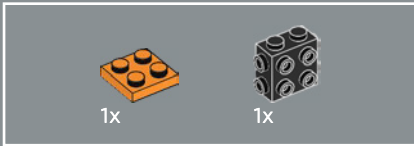
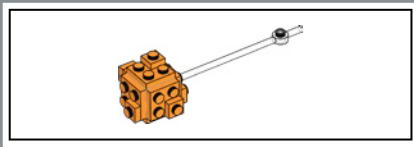

16

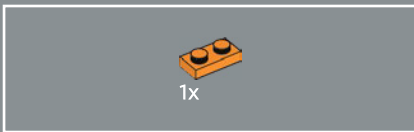
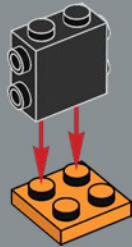

17

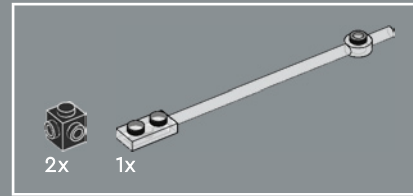
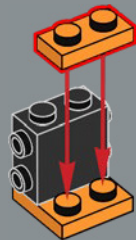

18

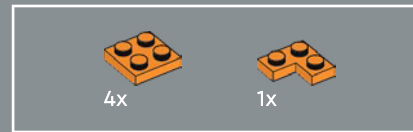
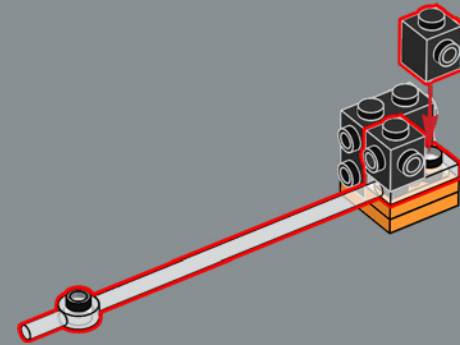

19

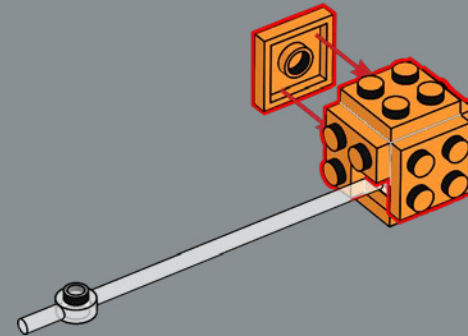



3x

20

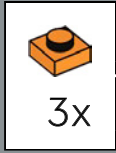

3x

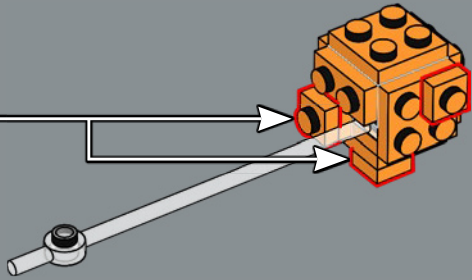

3x

21

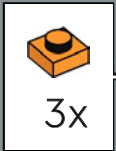

3x

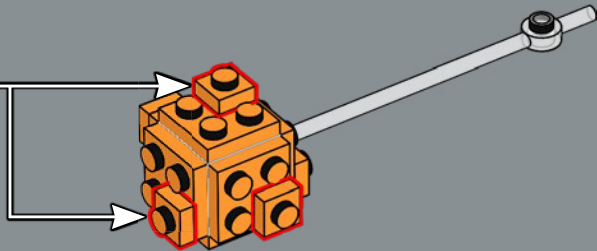

22

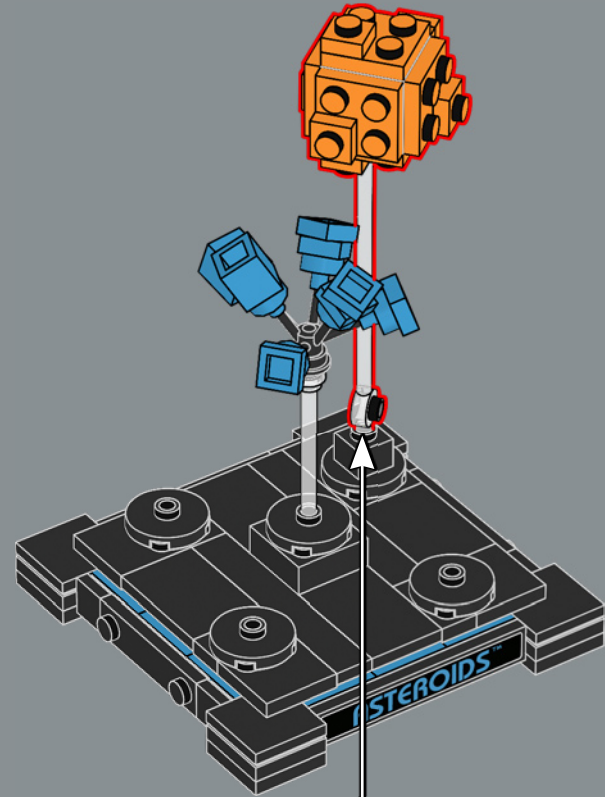



23

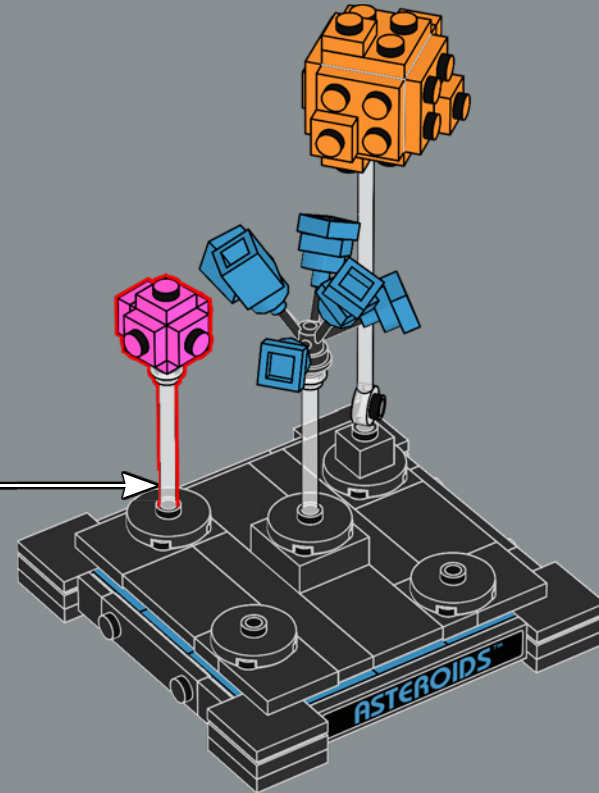
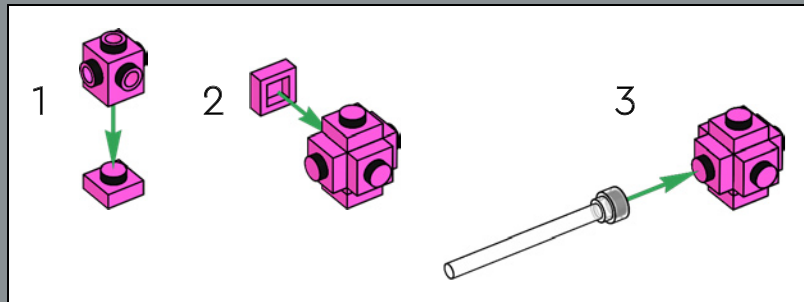

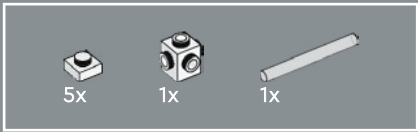

24

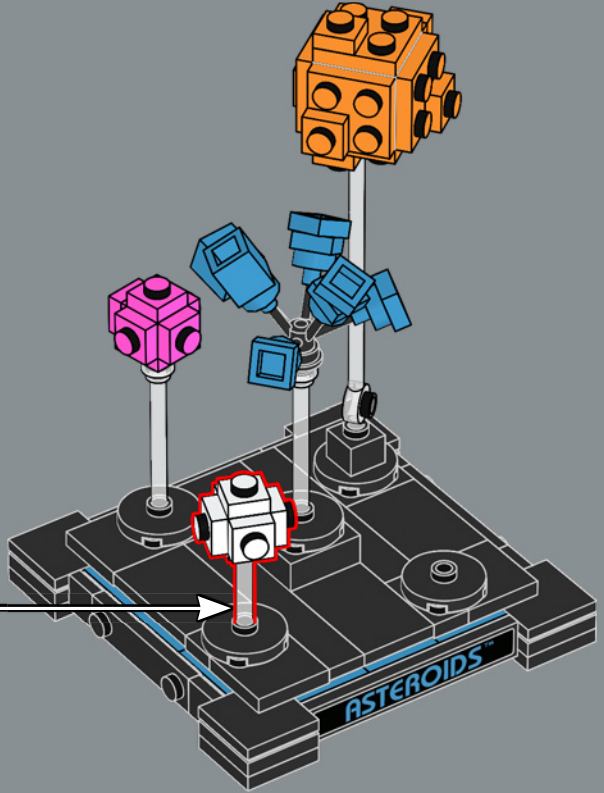
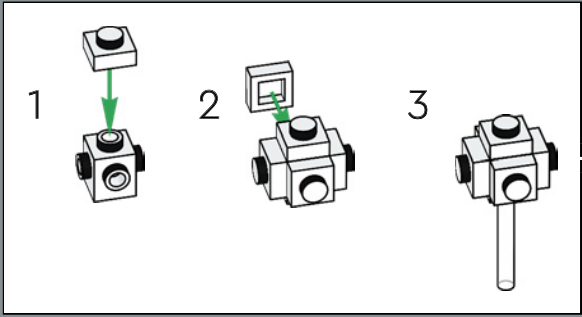

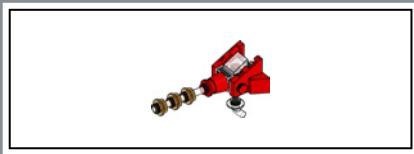

25

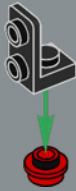

26

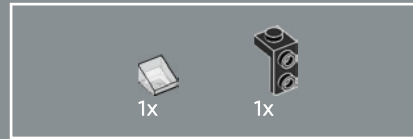

27

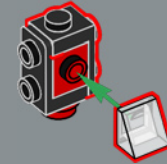

28





2x

29

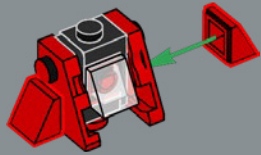

1x



1x

30

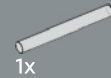
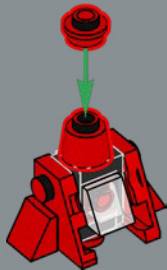

1x

31



3x

32



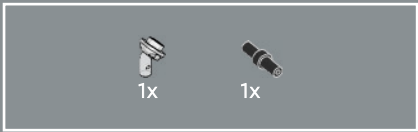

33

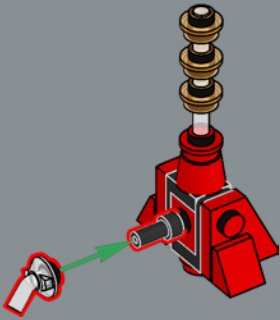

34

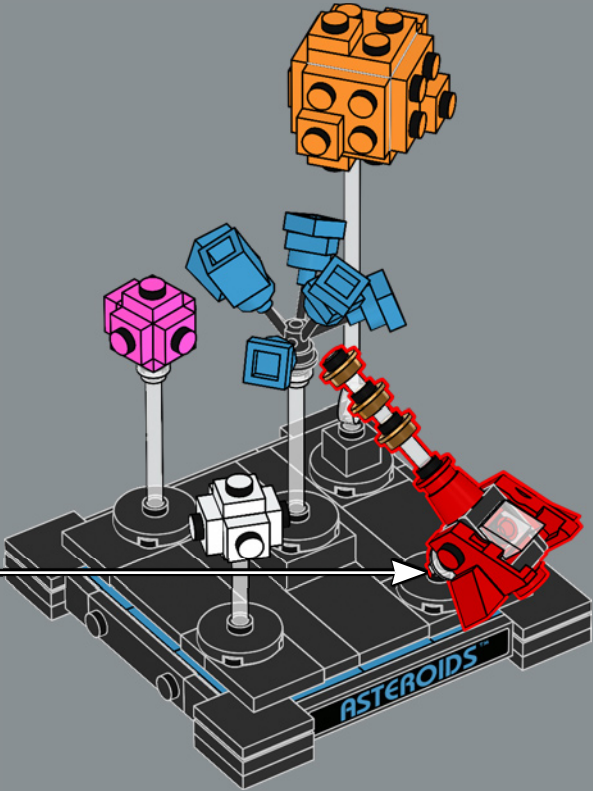

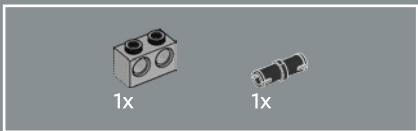
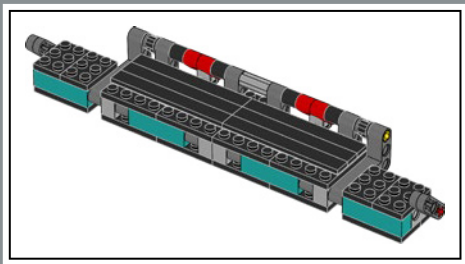

104

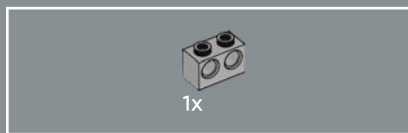
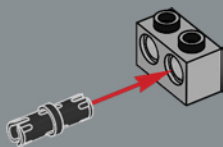

105

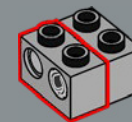

106

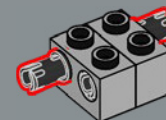

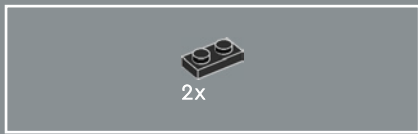

107

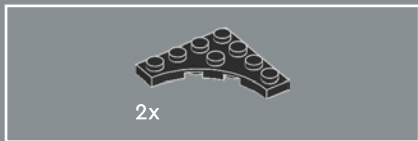
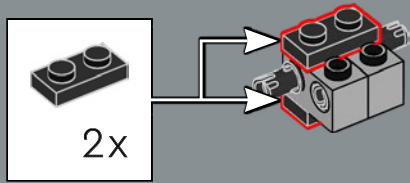

108

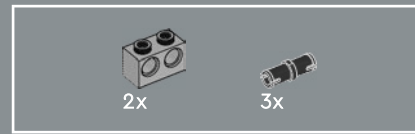
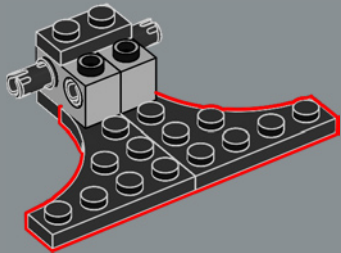

109

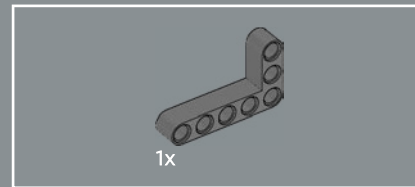
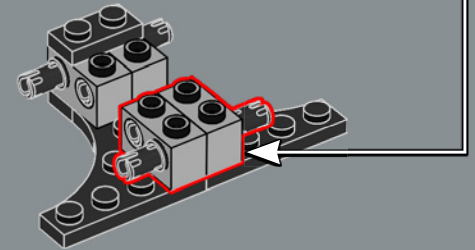
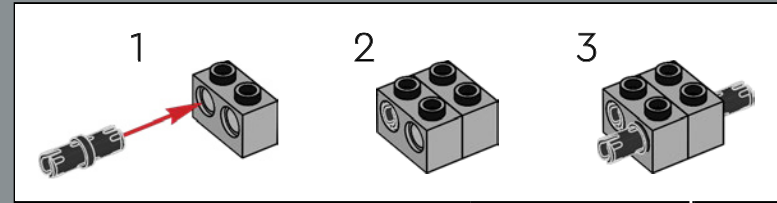

110

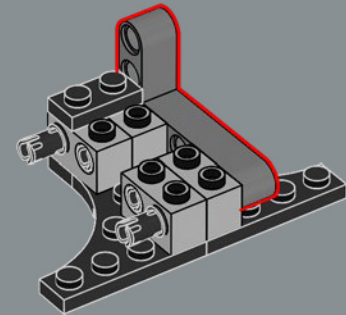

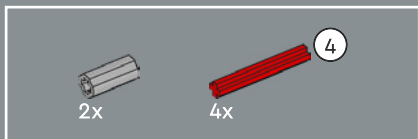

111

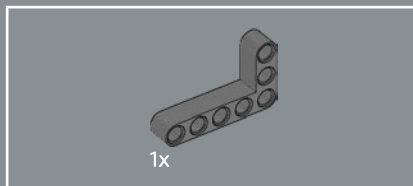
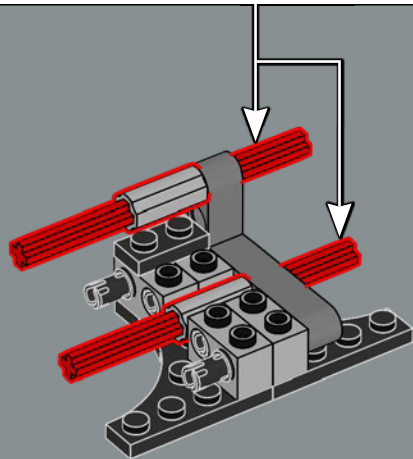
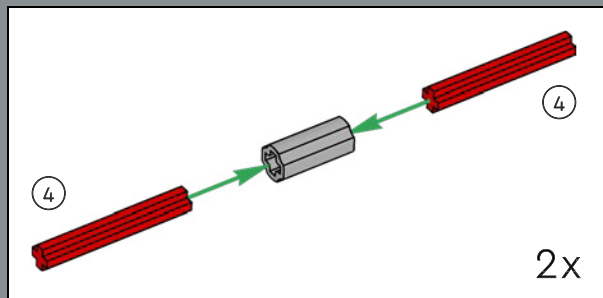

112

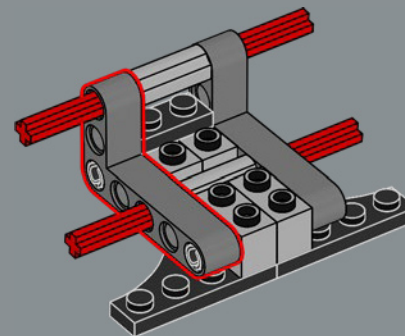

113

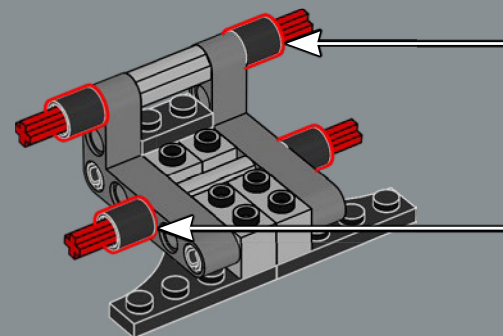



114

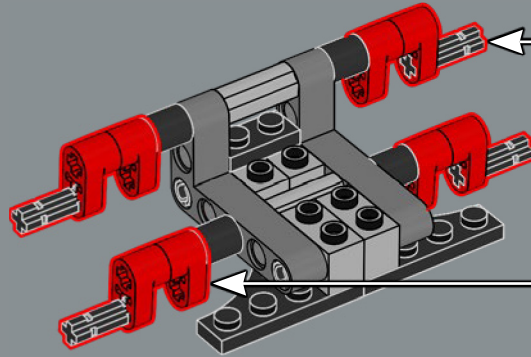
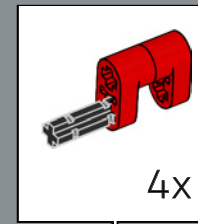

115

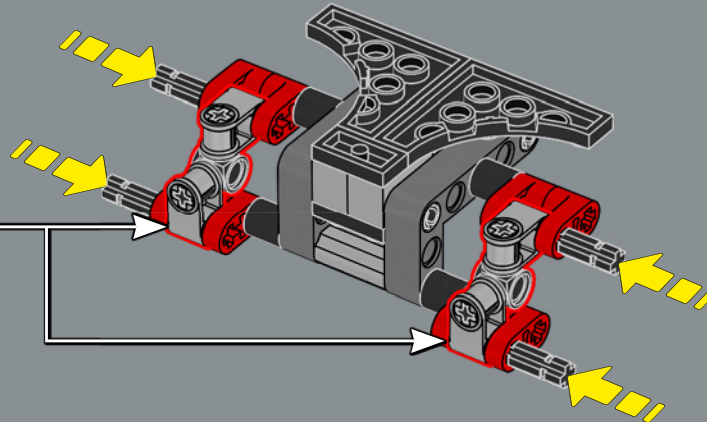
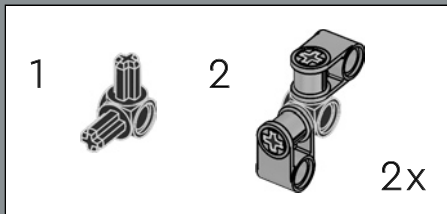

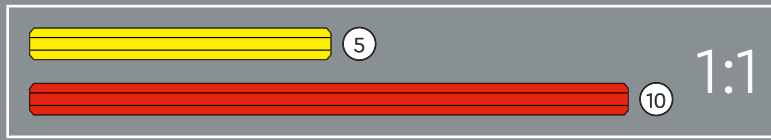
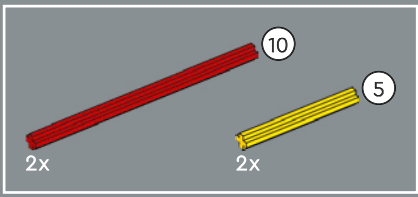

116

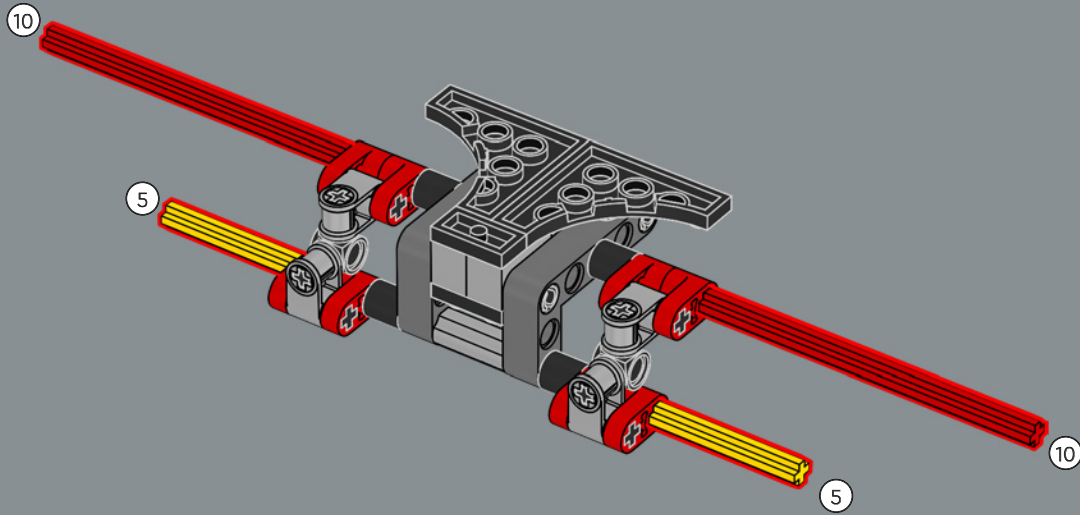

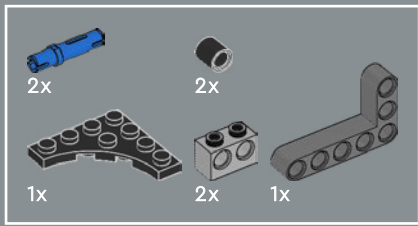

117

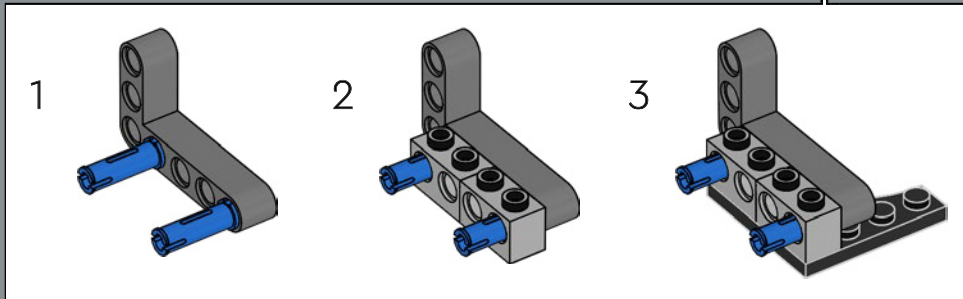
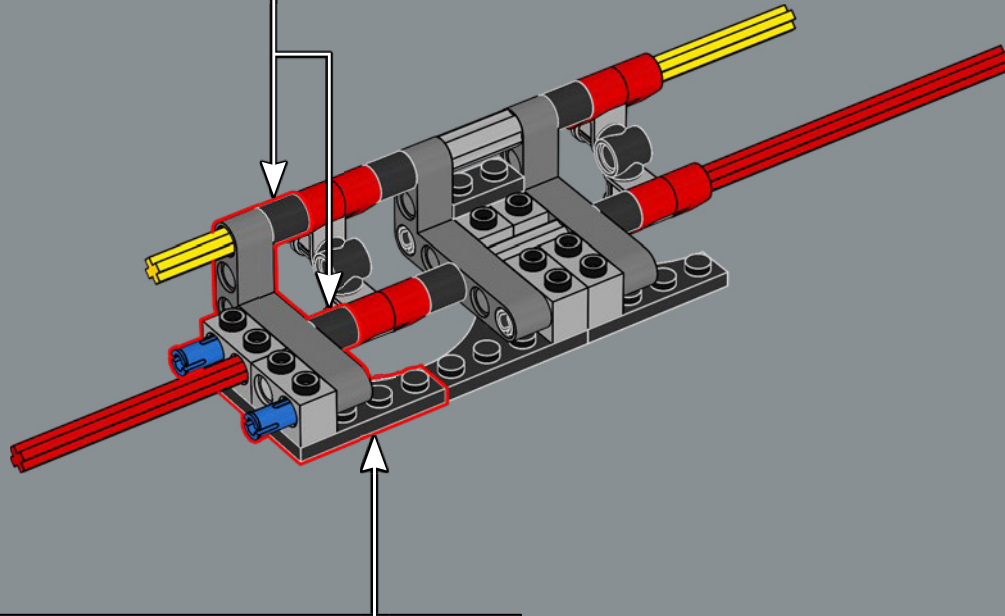

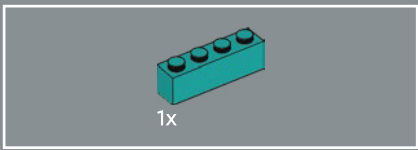

118

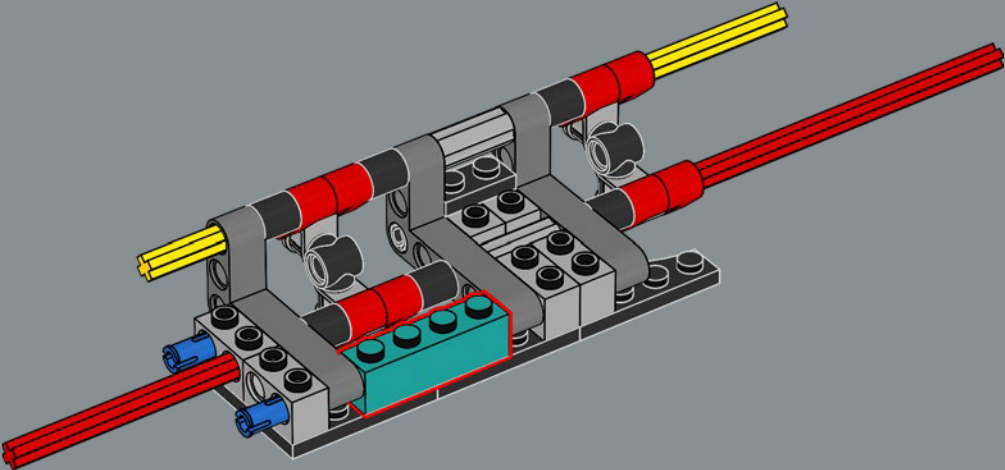

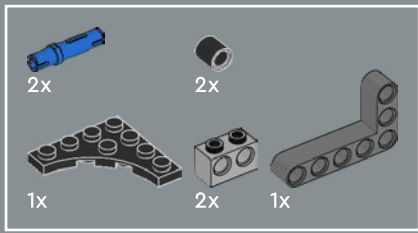

119

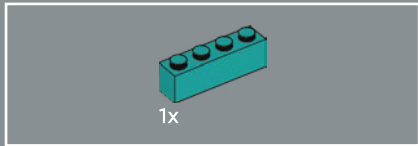
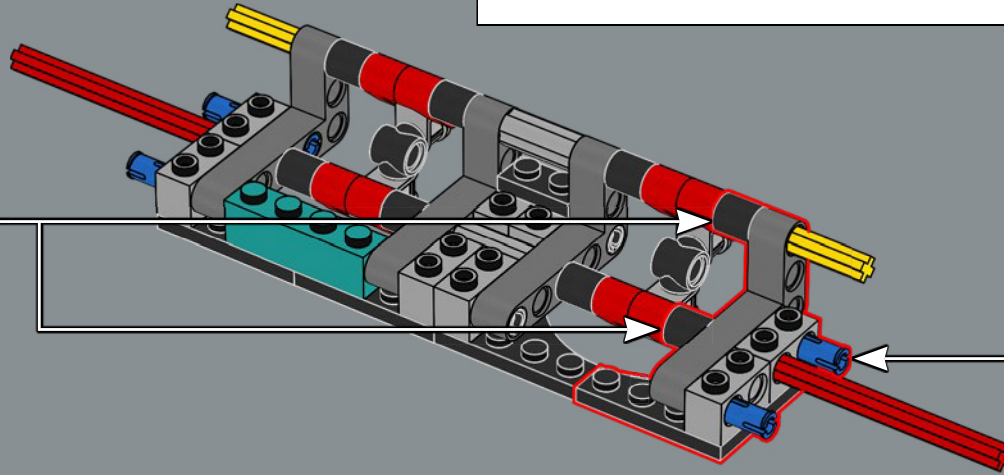
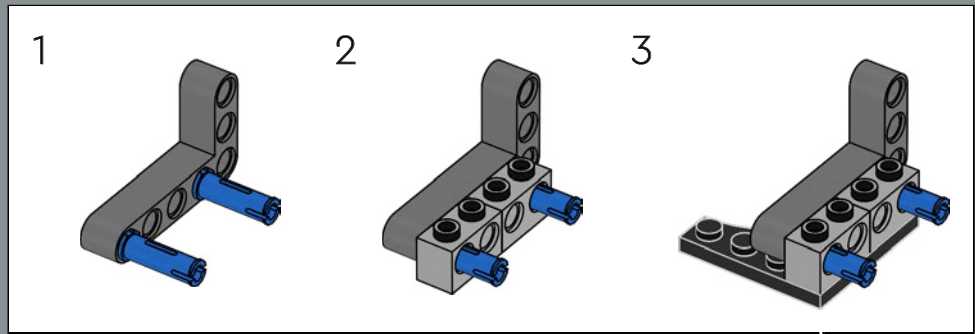

120

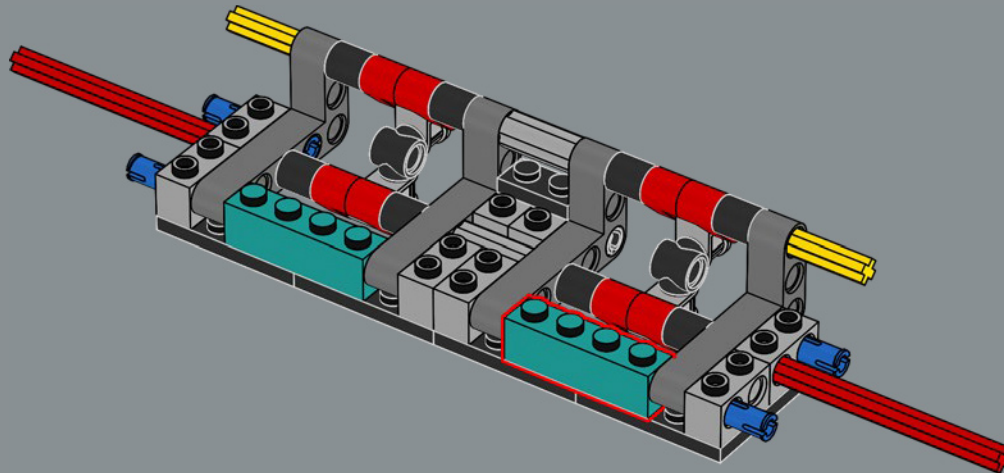

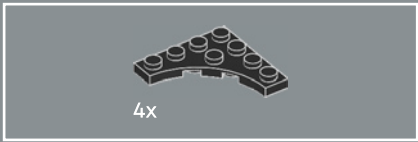

121

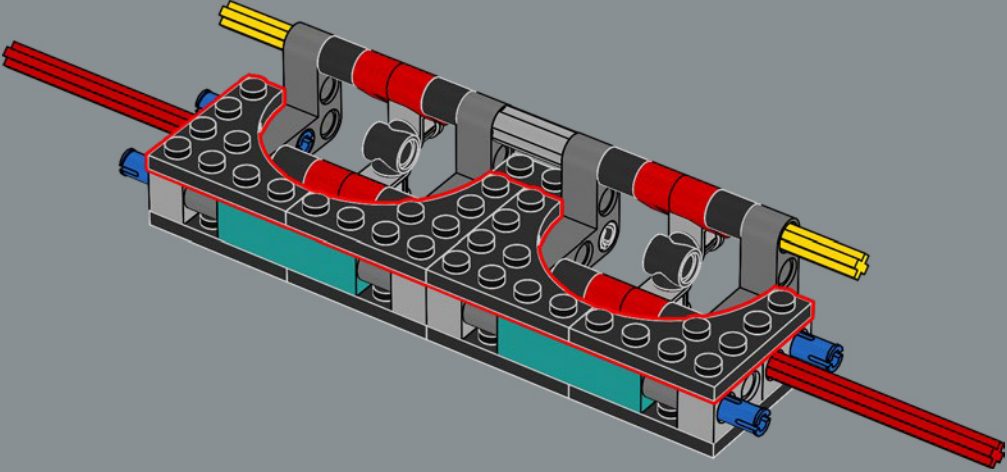

122

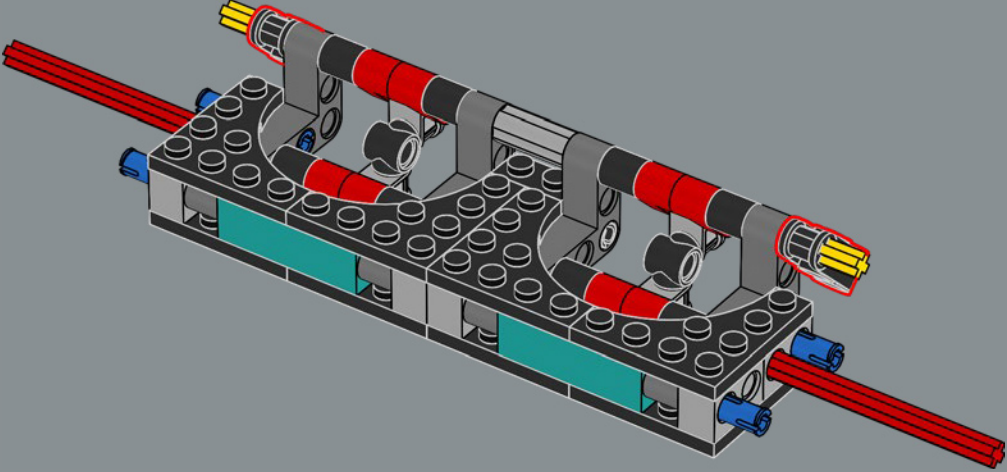

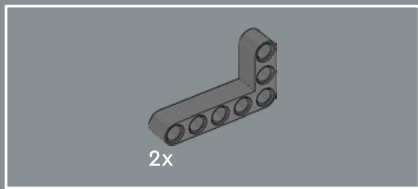

123

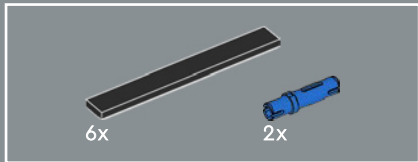
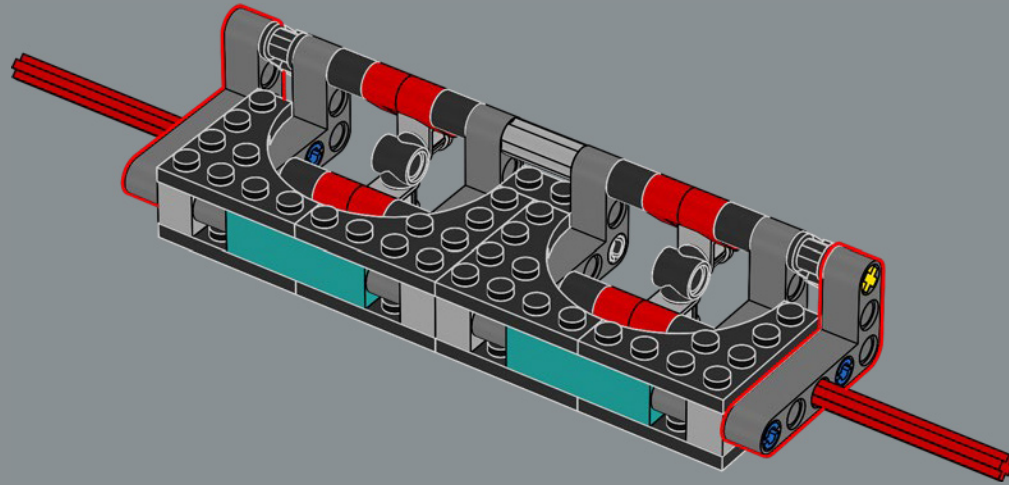

124

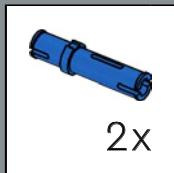
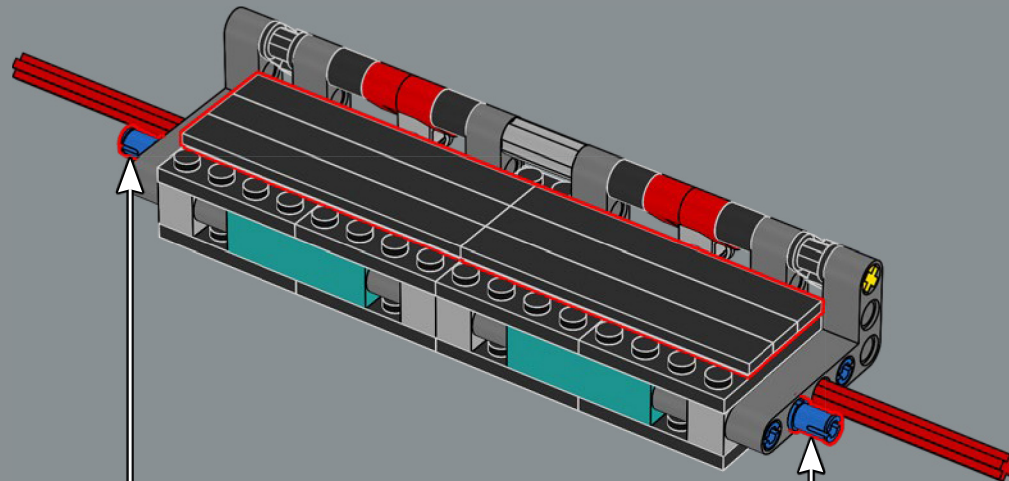

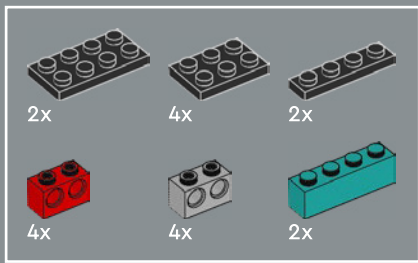

125

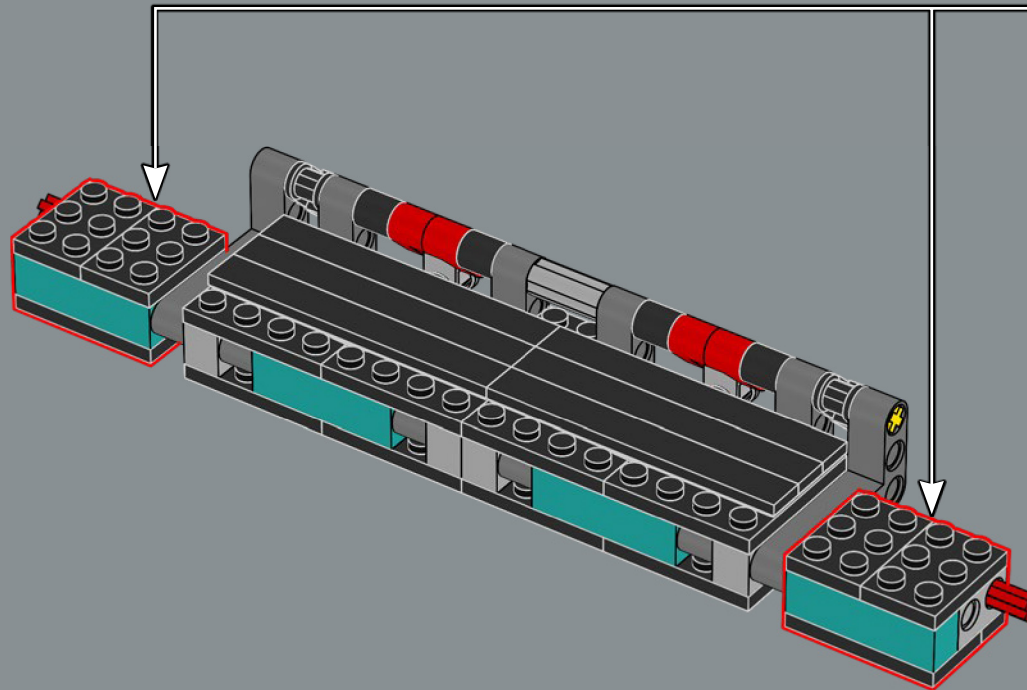
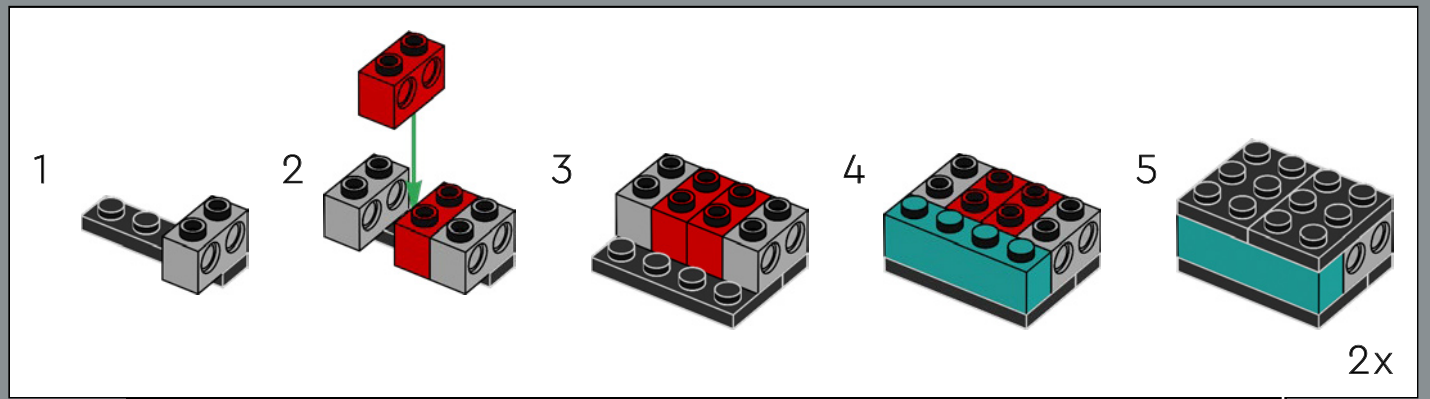



126

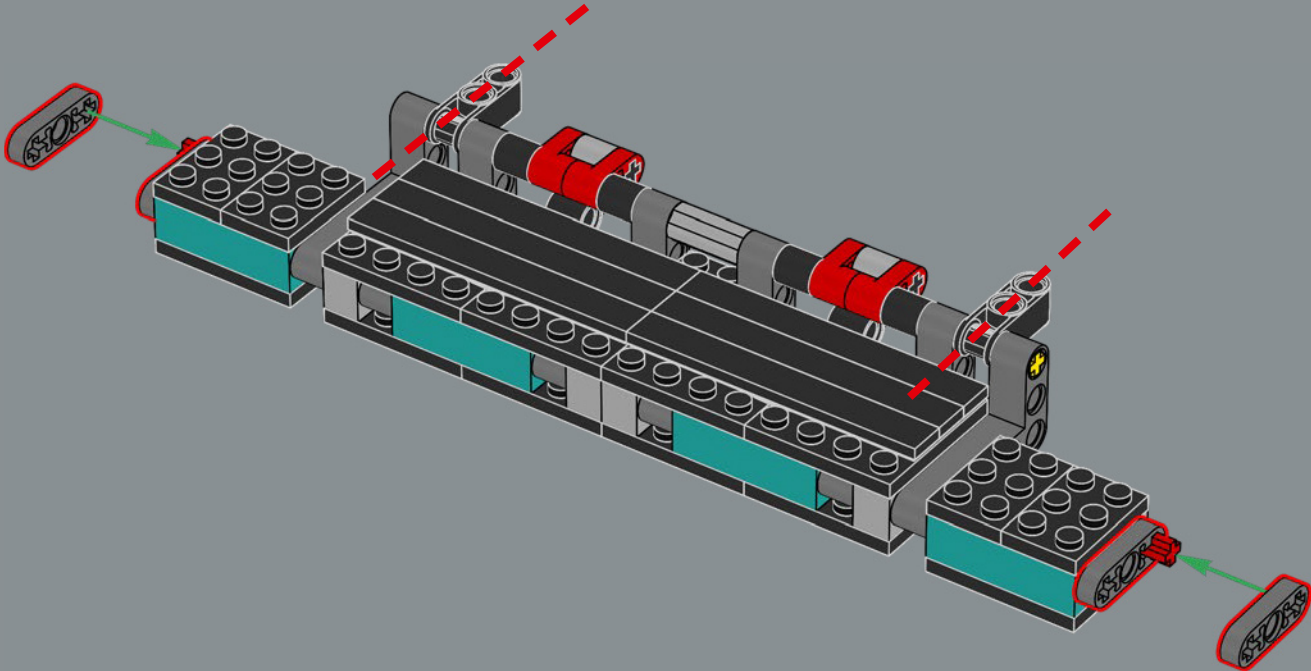

127

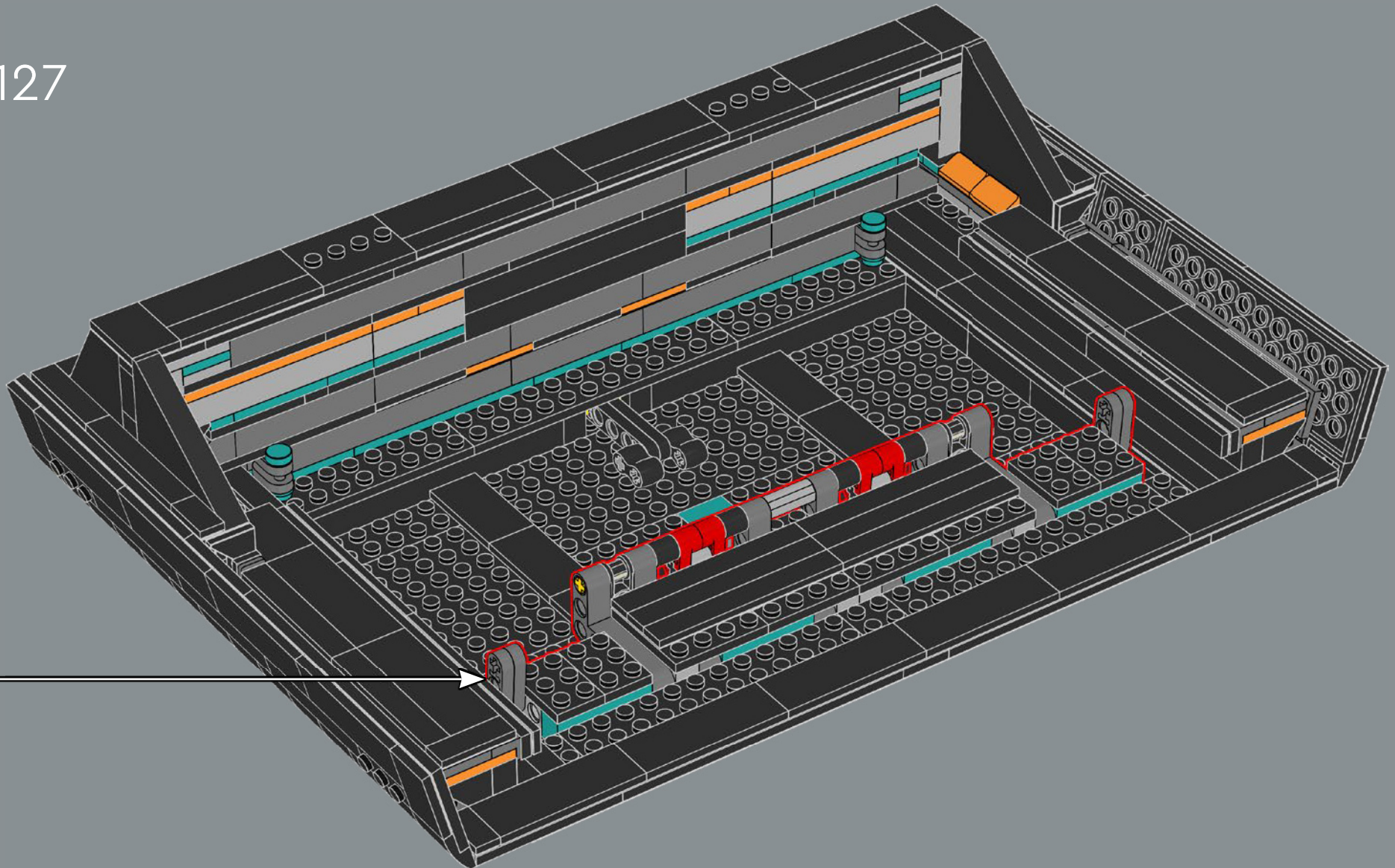

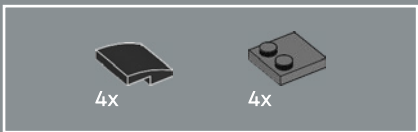

128

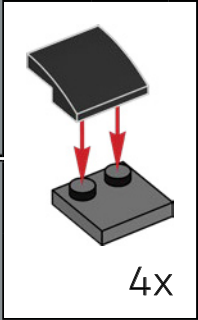
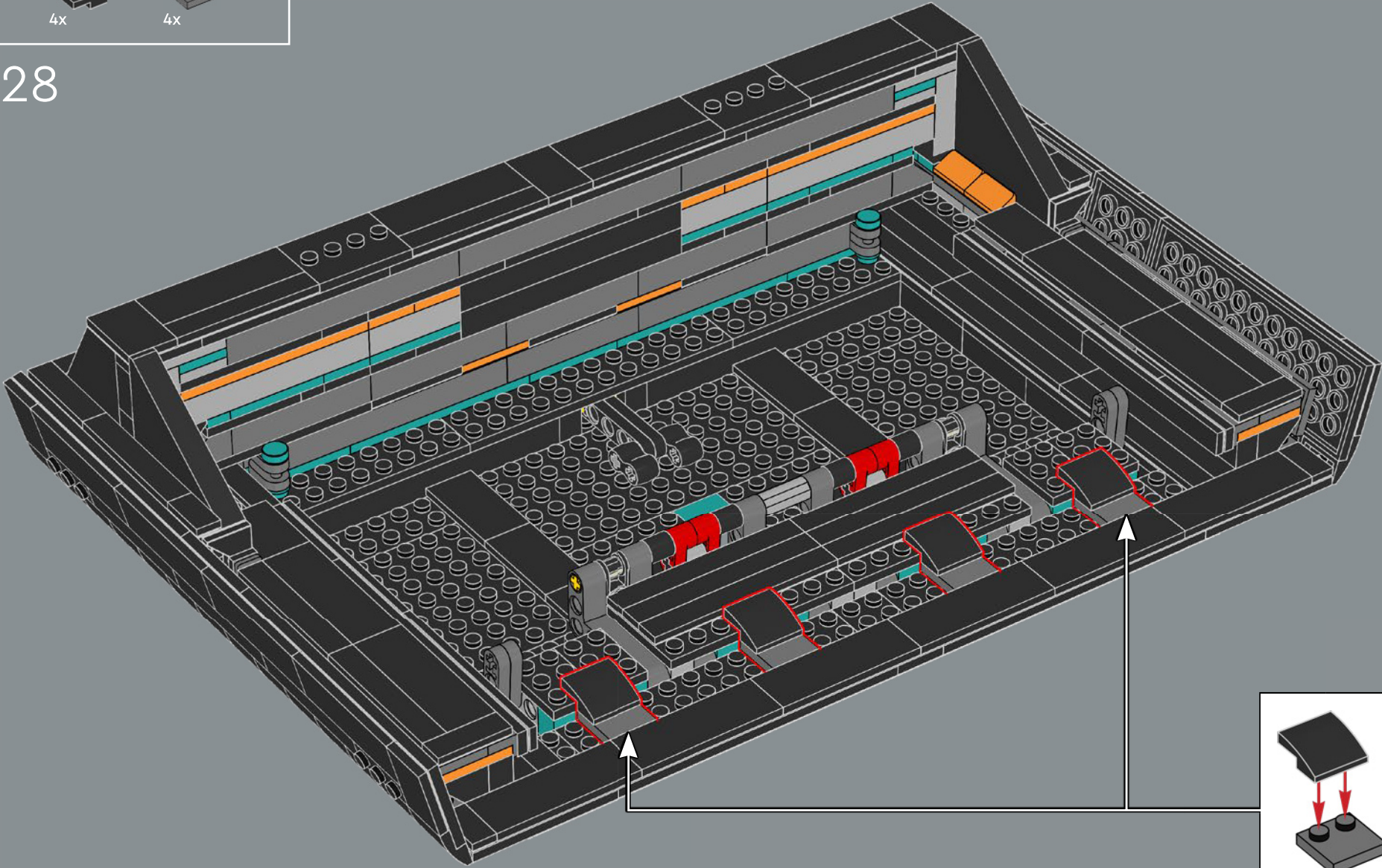



4x

129

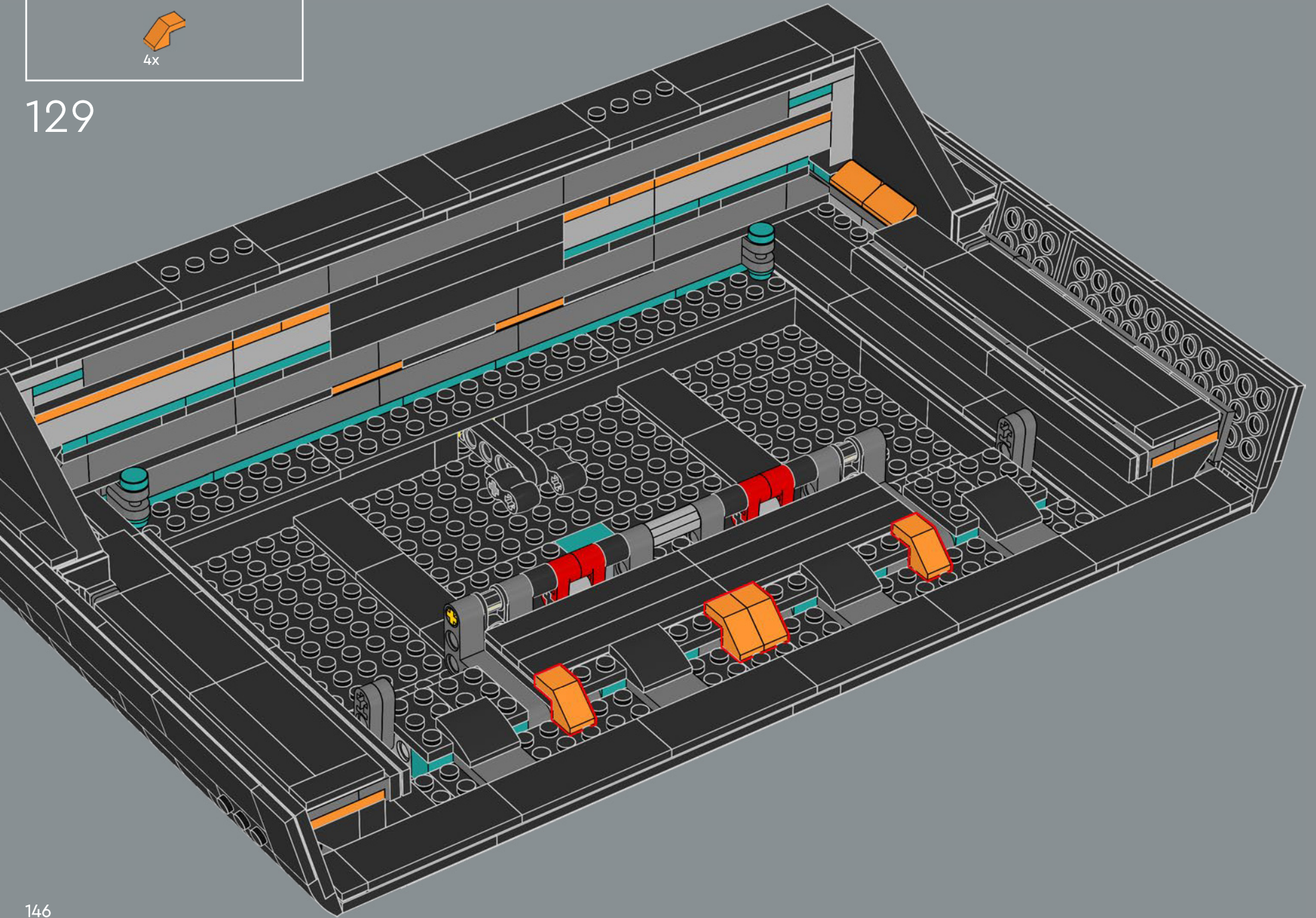

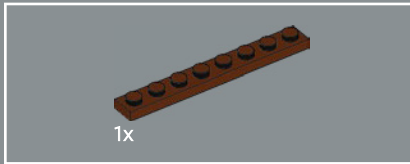
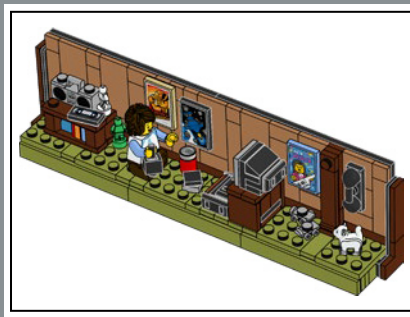

1x

130

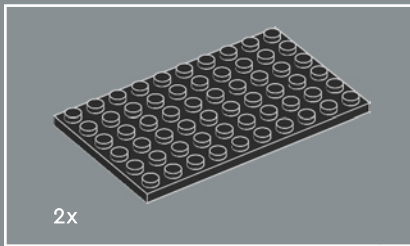
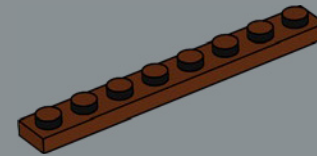

2x

131

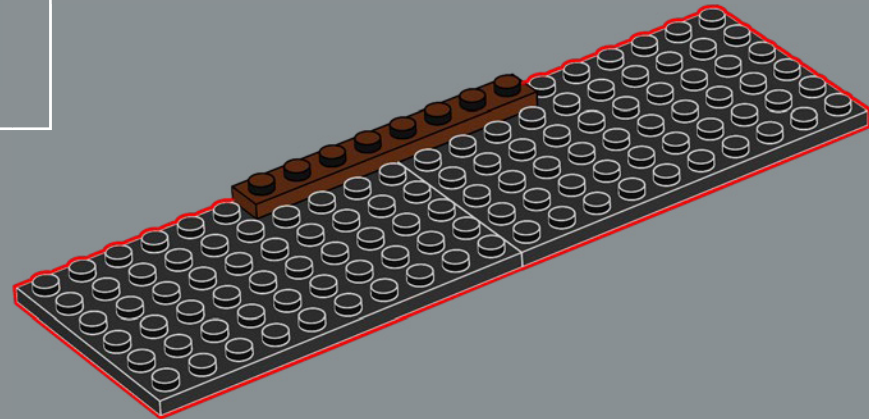

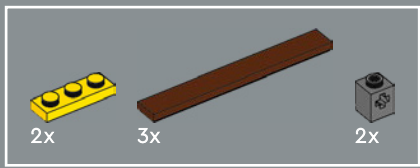

132

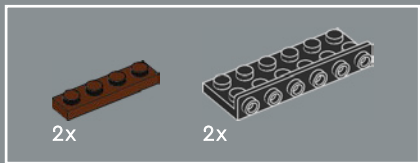
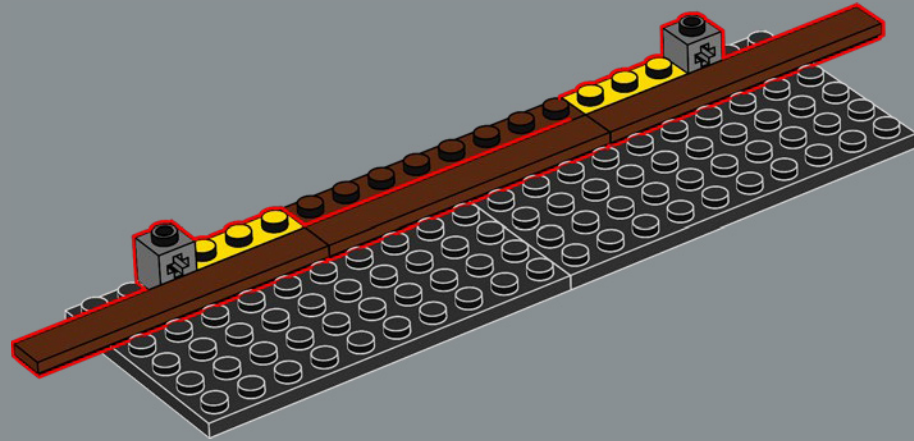

133

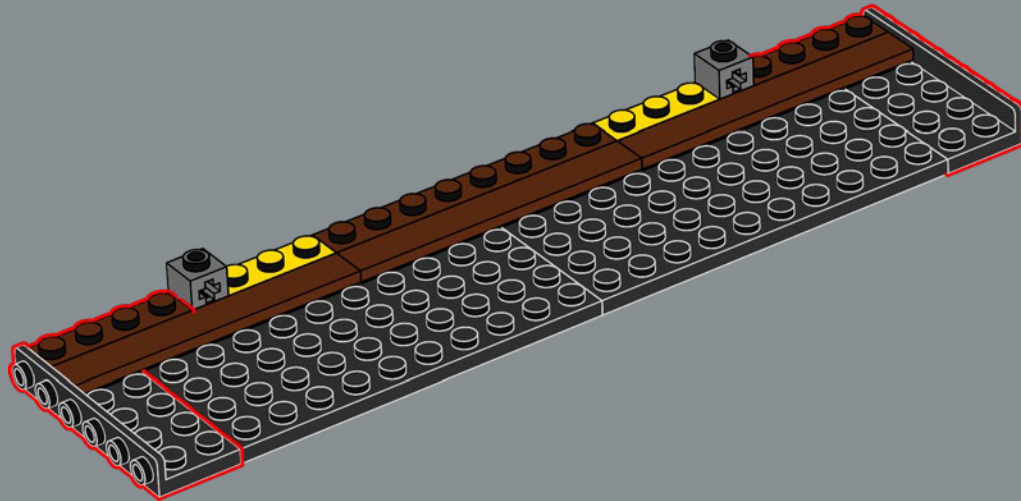

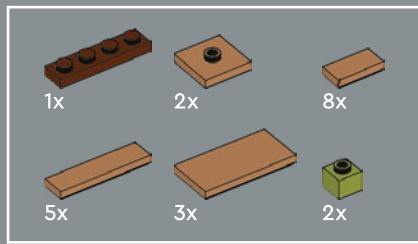

134

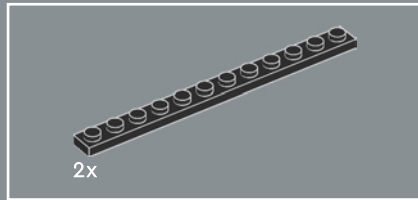
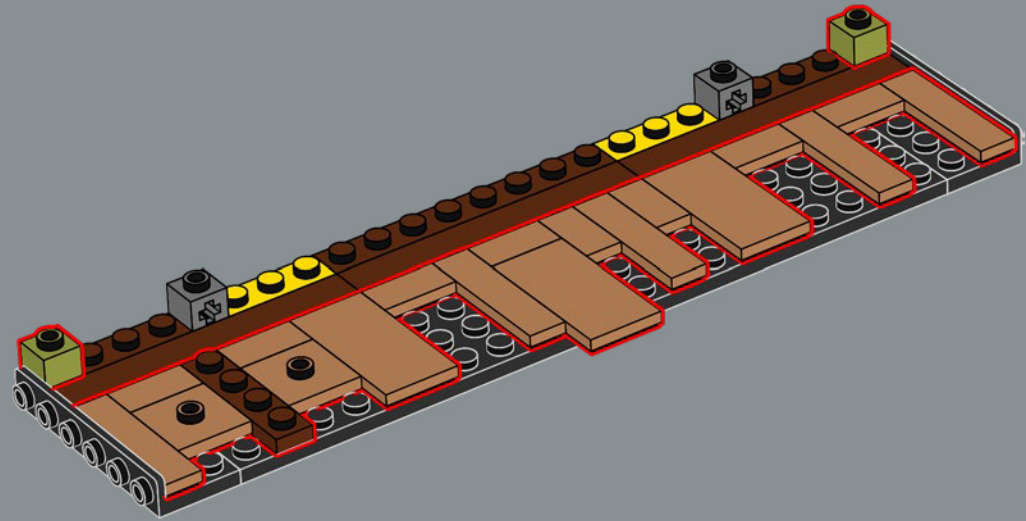

135

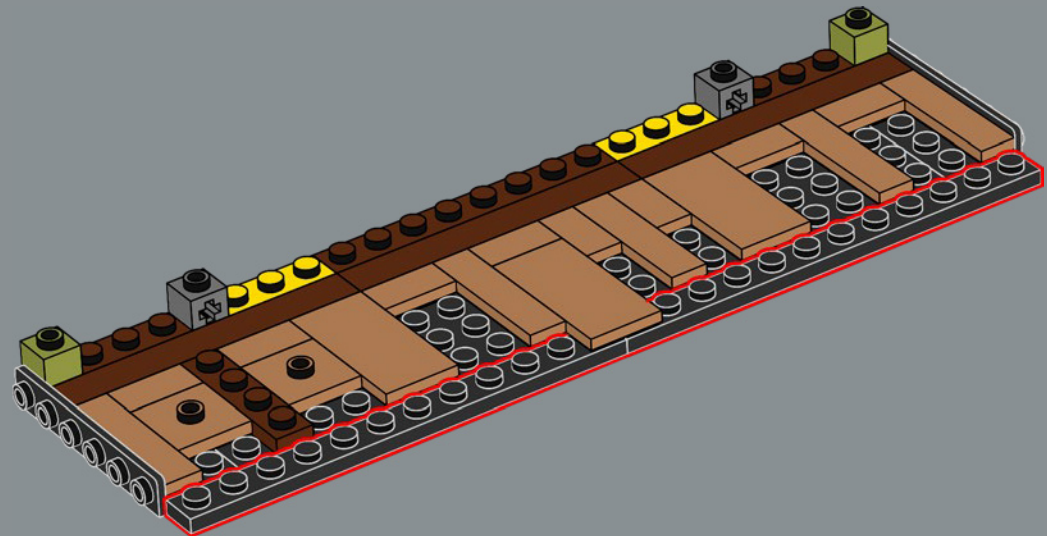

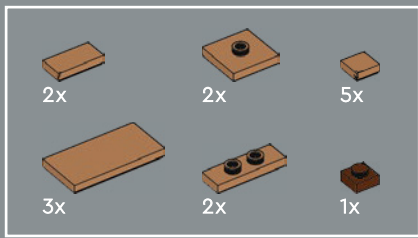

136

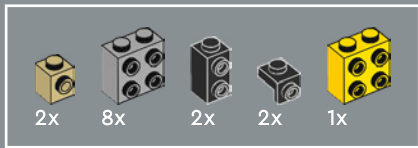
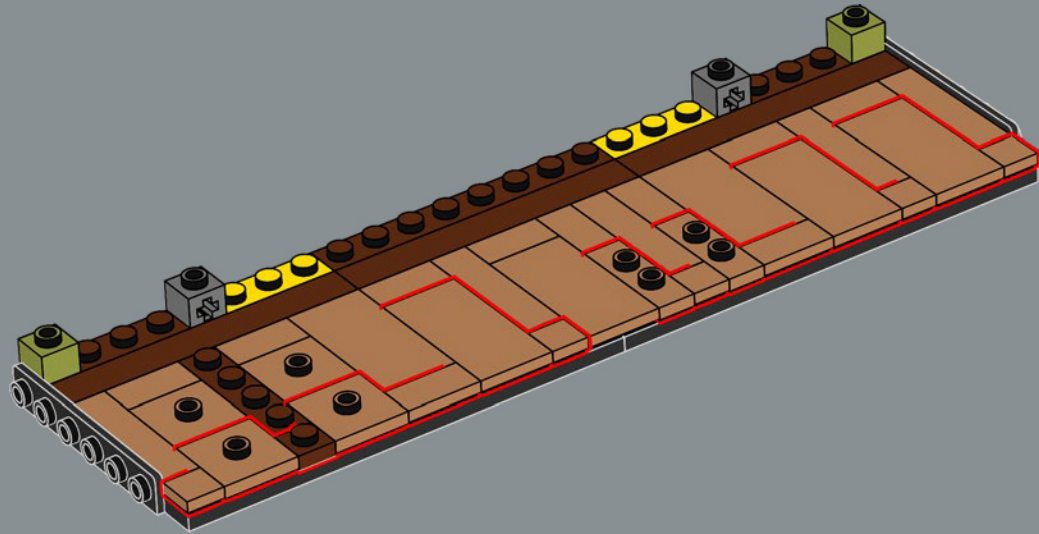

137

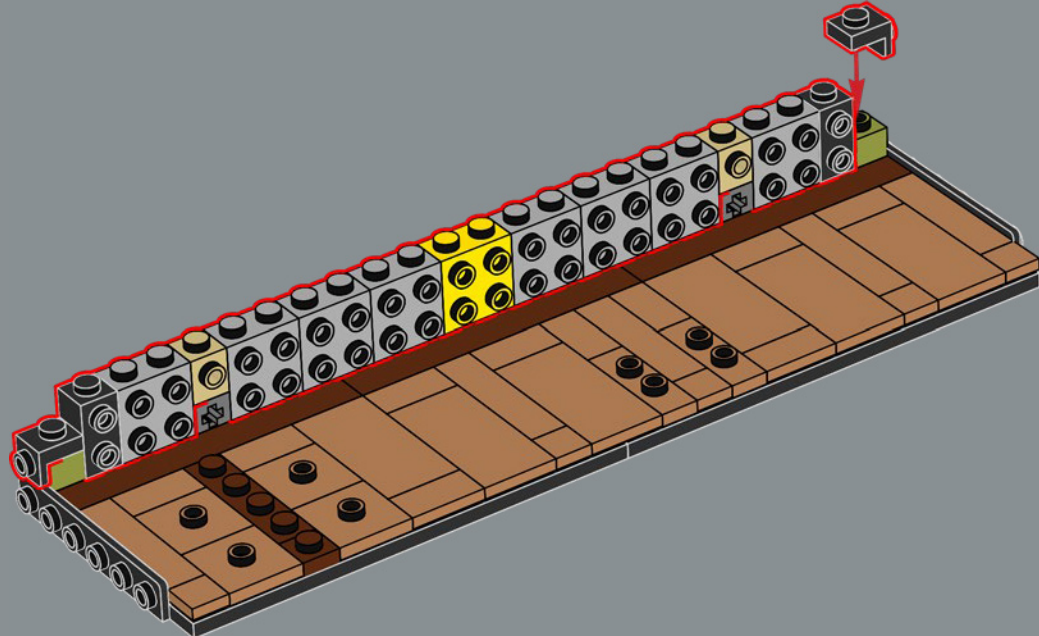

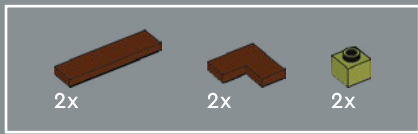

138

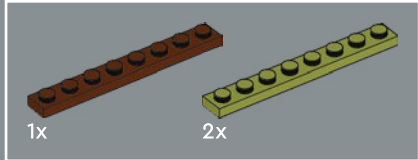
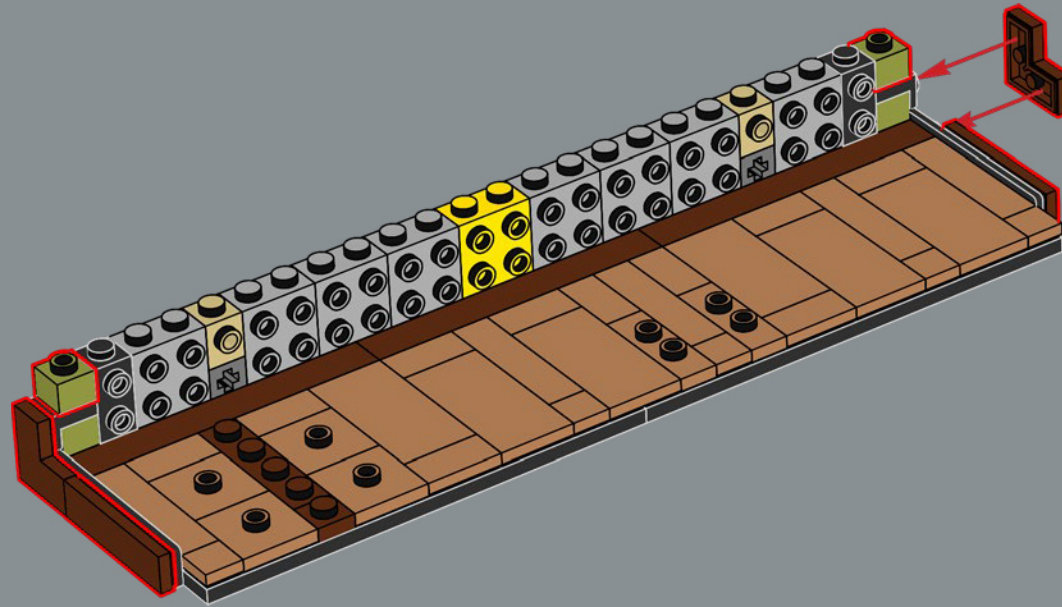

139

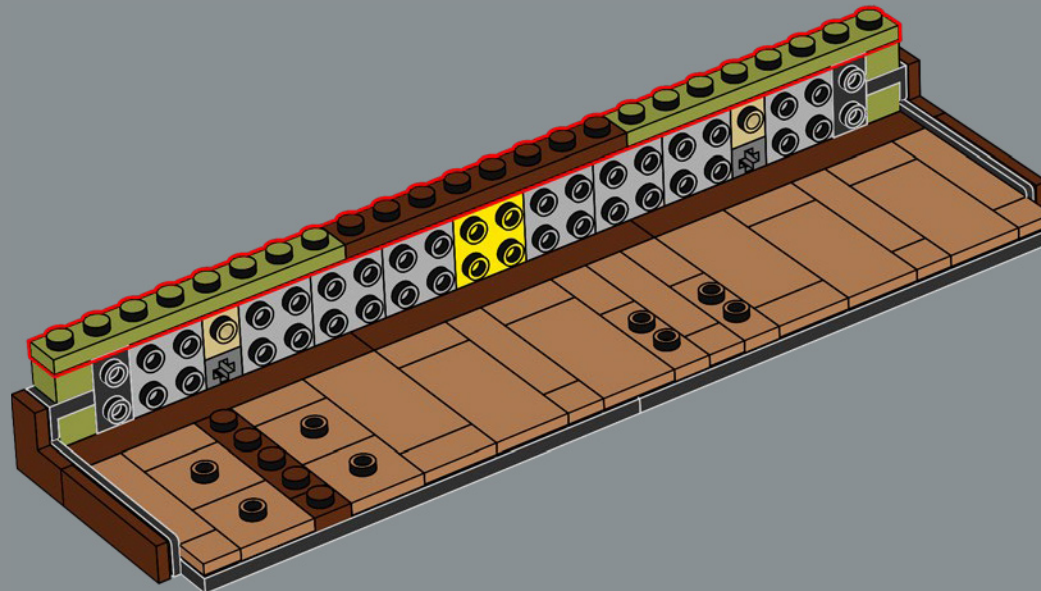

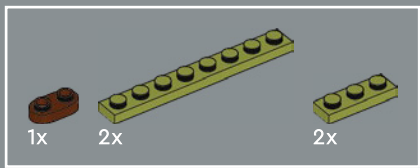

140

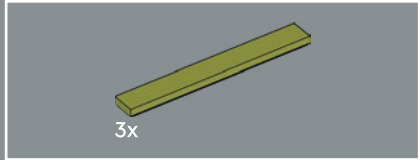
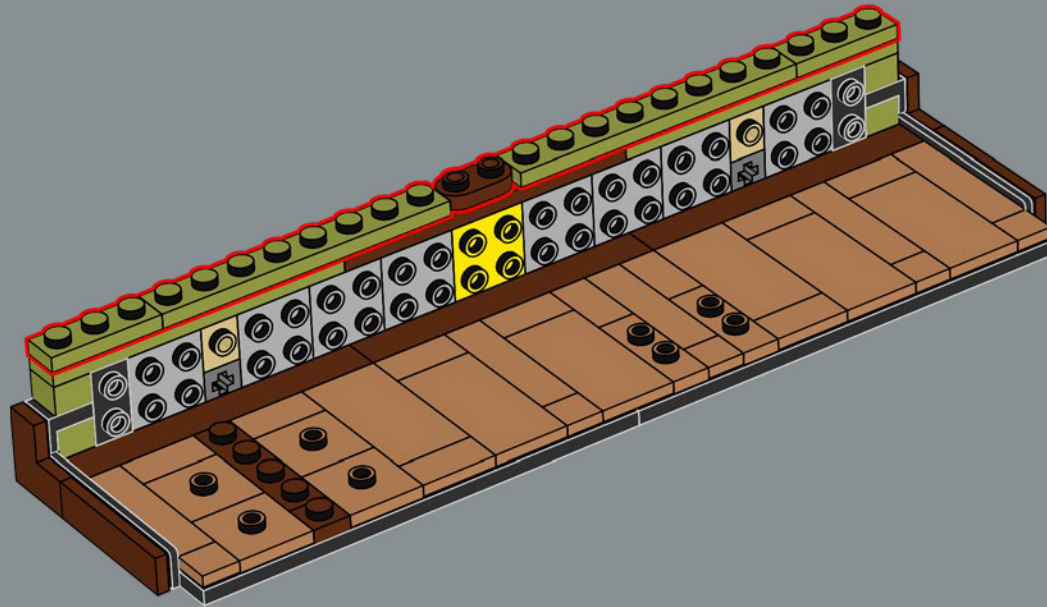

141

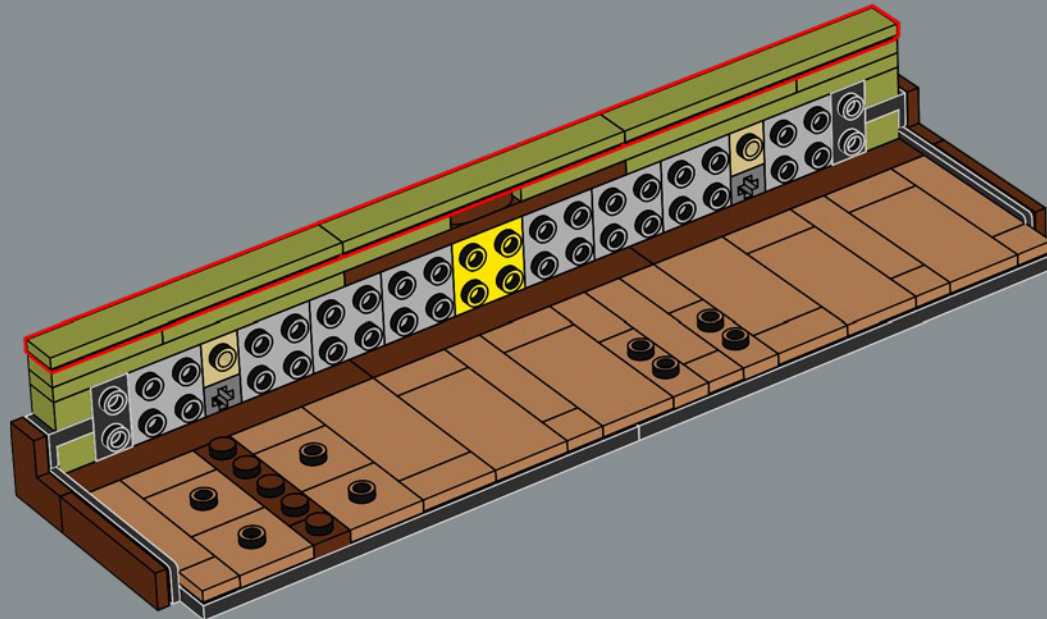

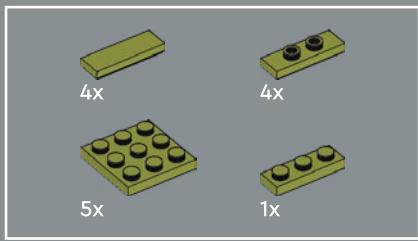

142

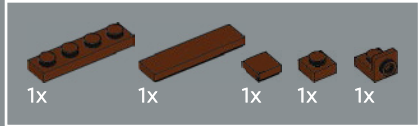
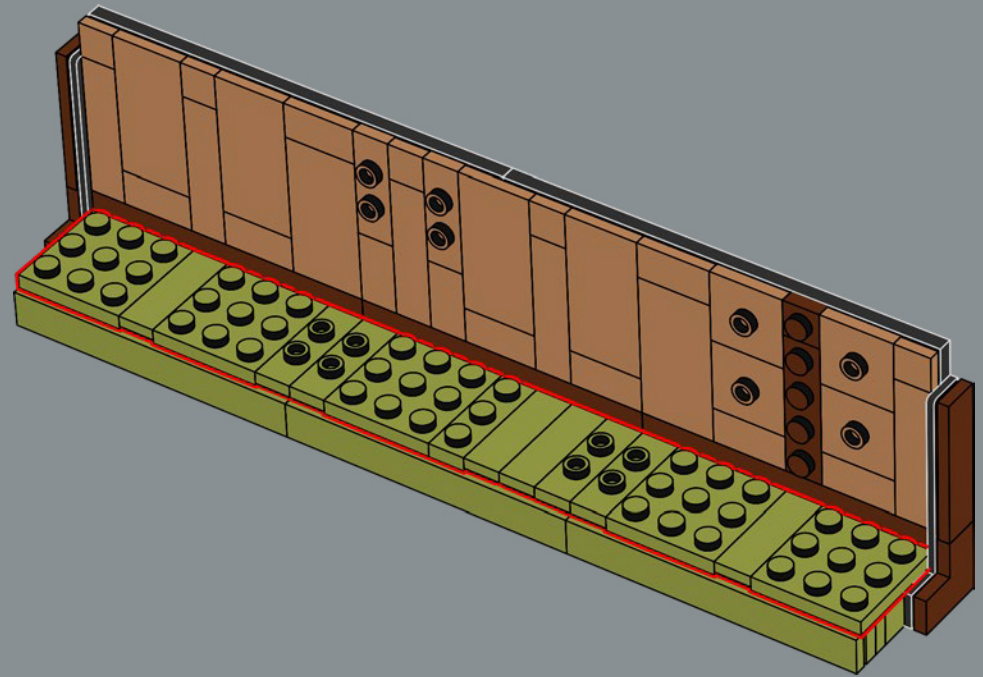

143

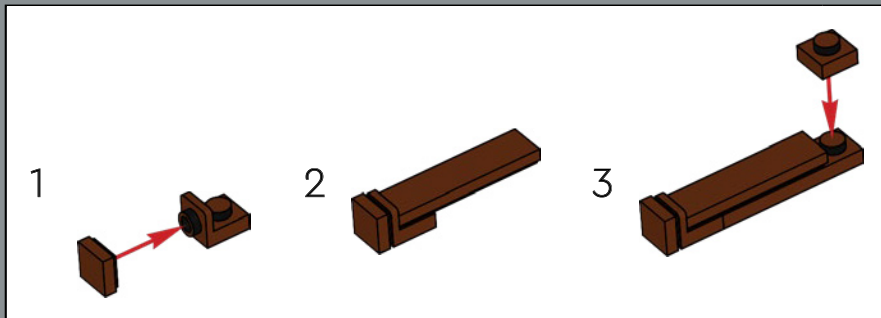
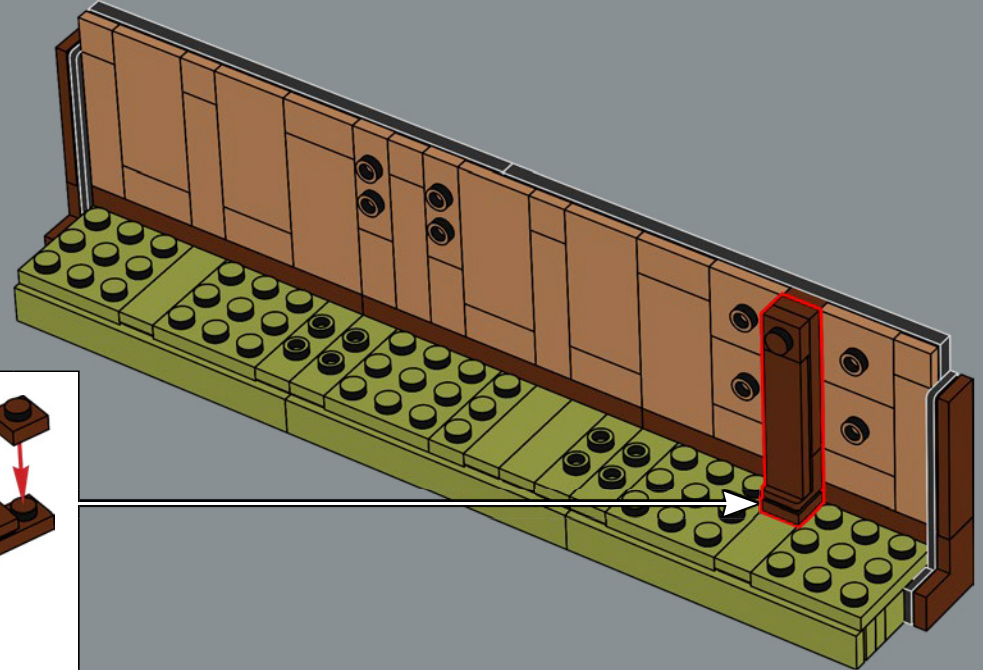

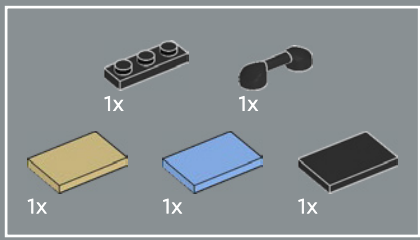

144

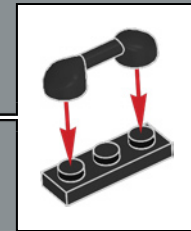
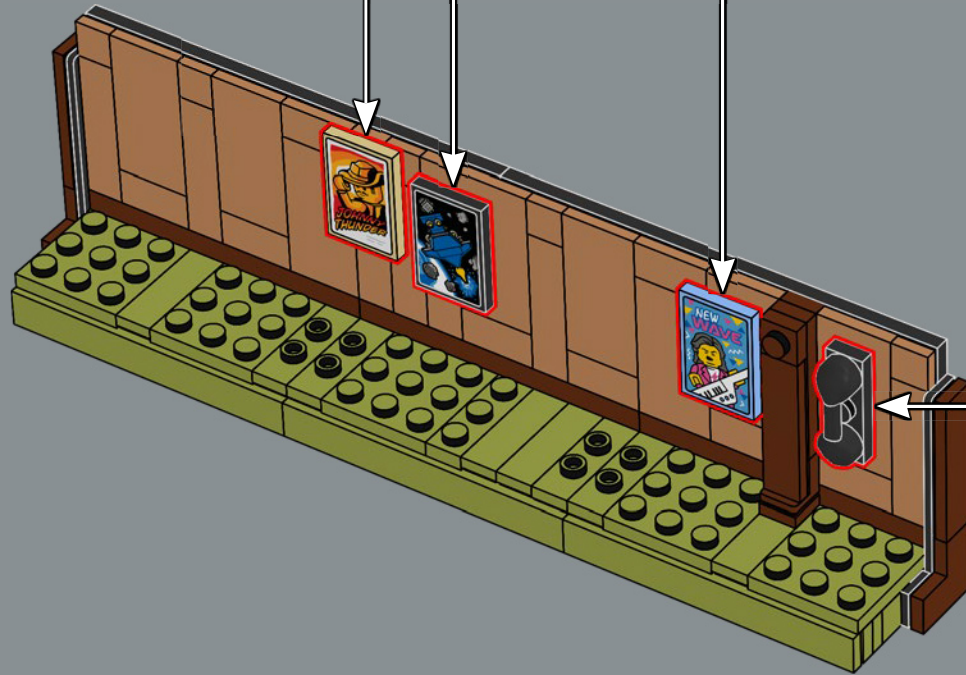
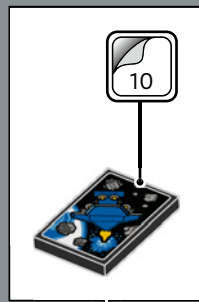

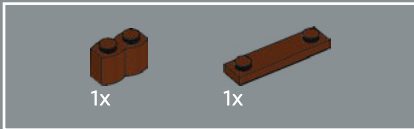
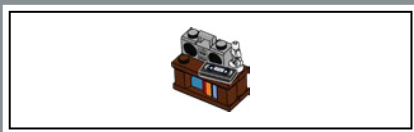

145

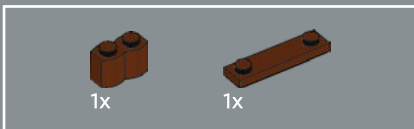
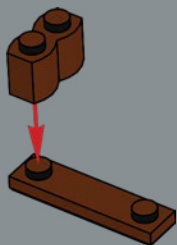

146

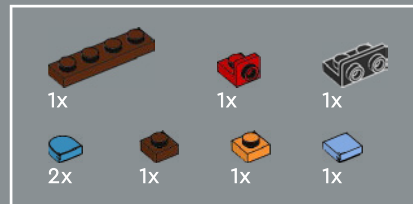
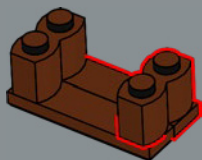

147

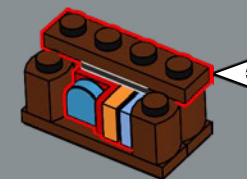
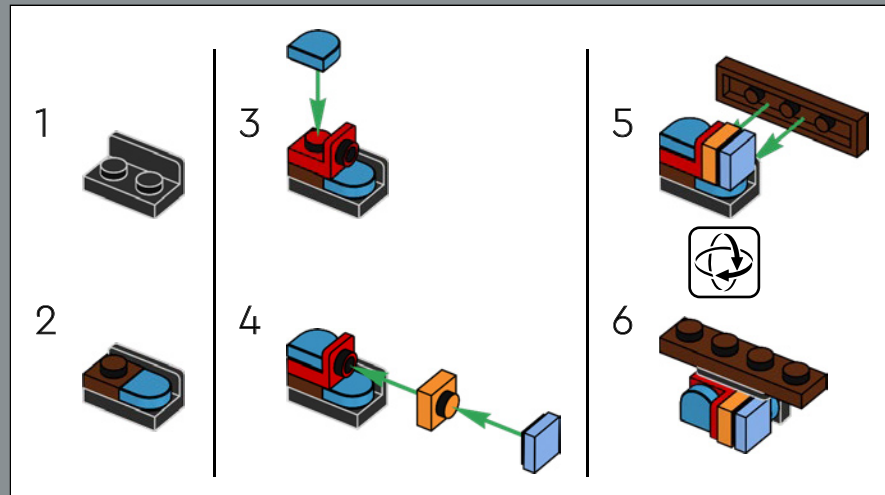

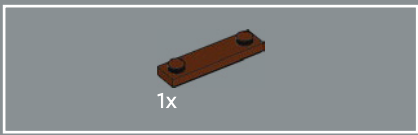

148

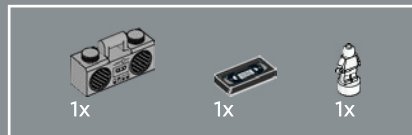
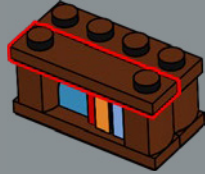

149



150

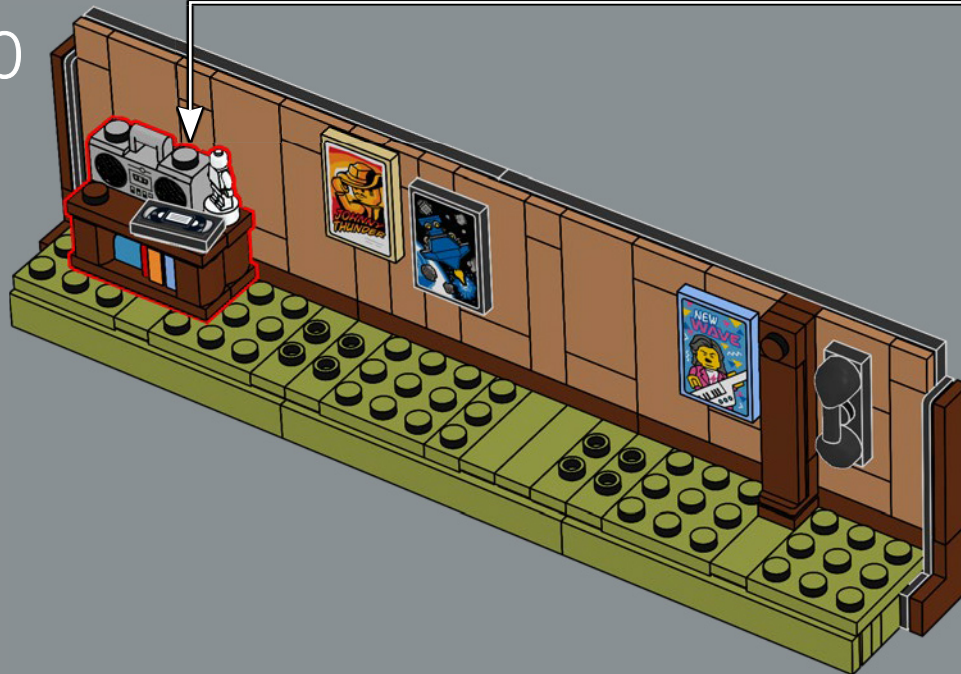

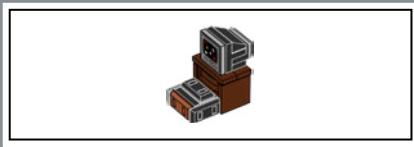

151

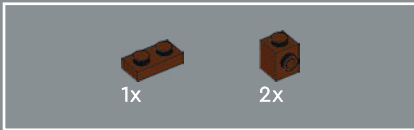
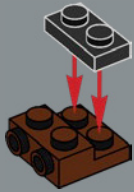

152

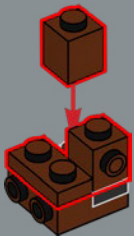

153

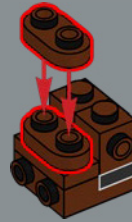

154

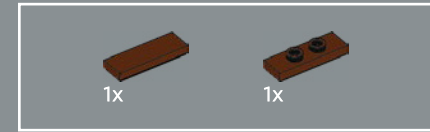
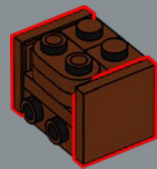

155

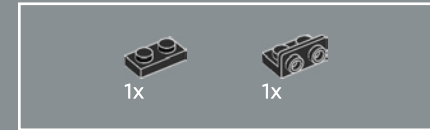
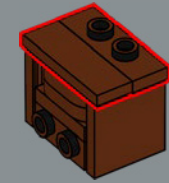

156

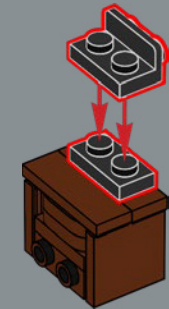



1x

157

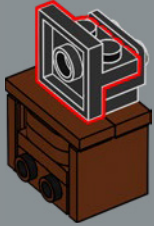

1x



1x



1x

158

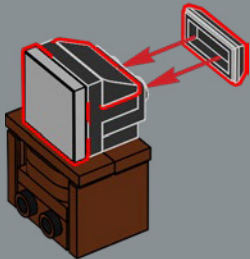

159



1x



3x



2x



1x

160

1

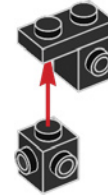

2

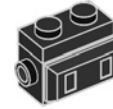

3

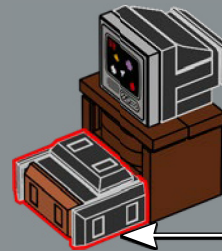

161

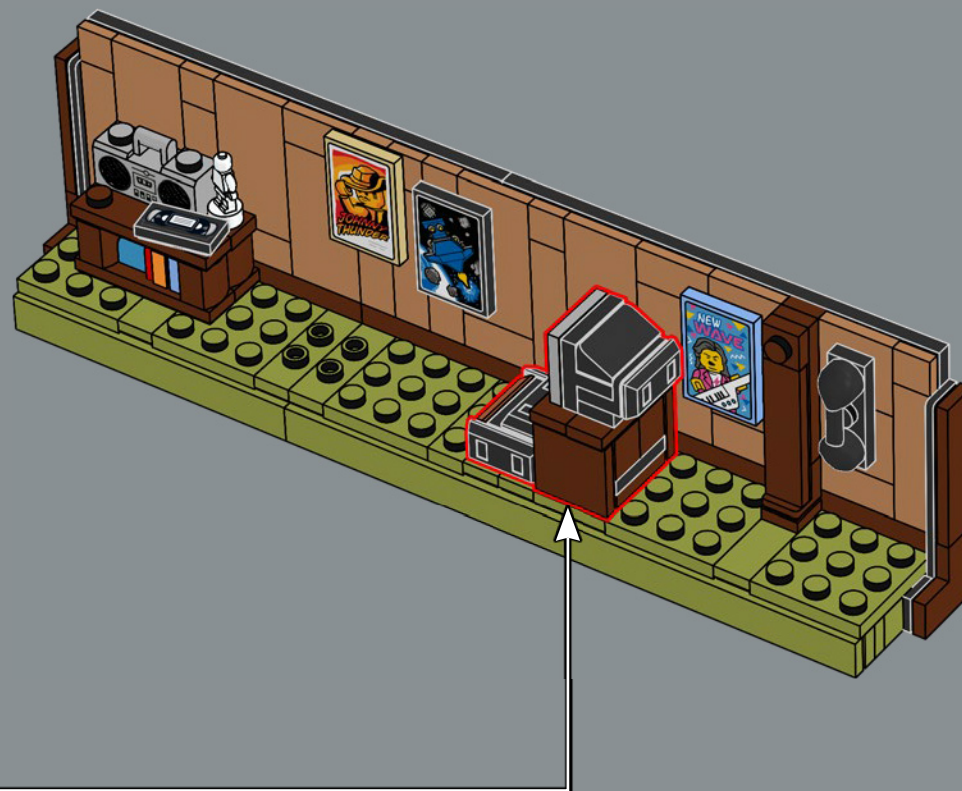



162

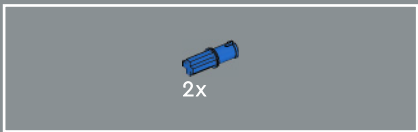

163

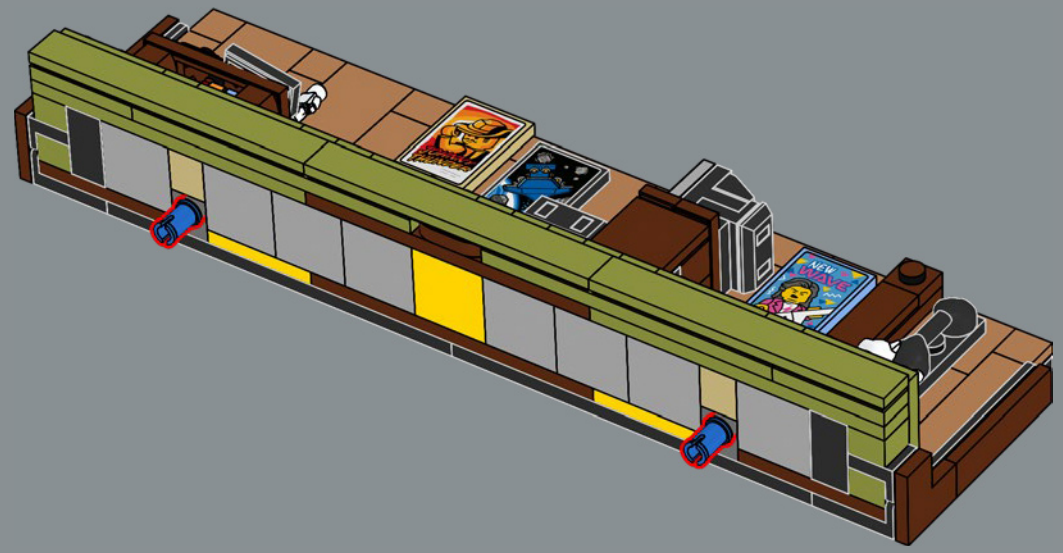

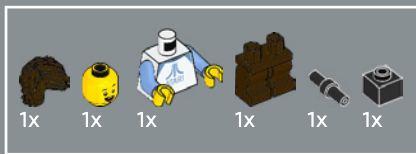

164

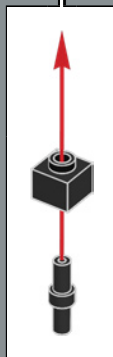
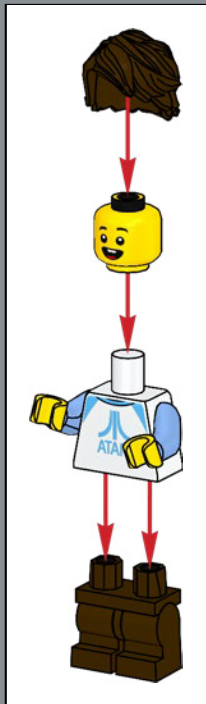

165

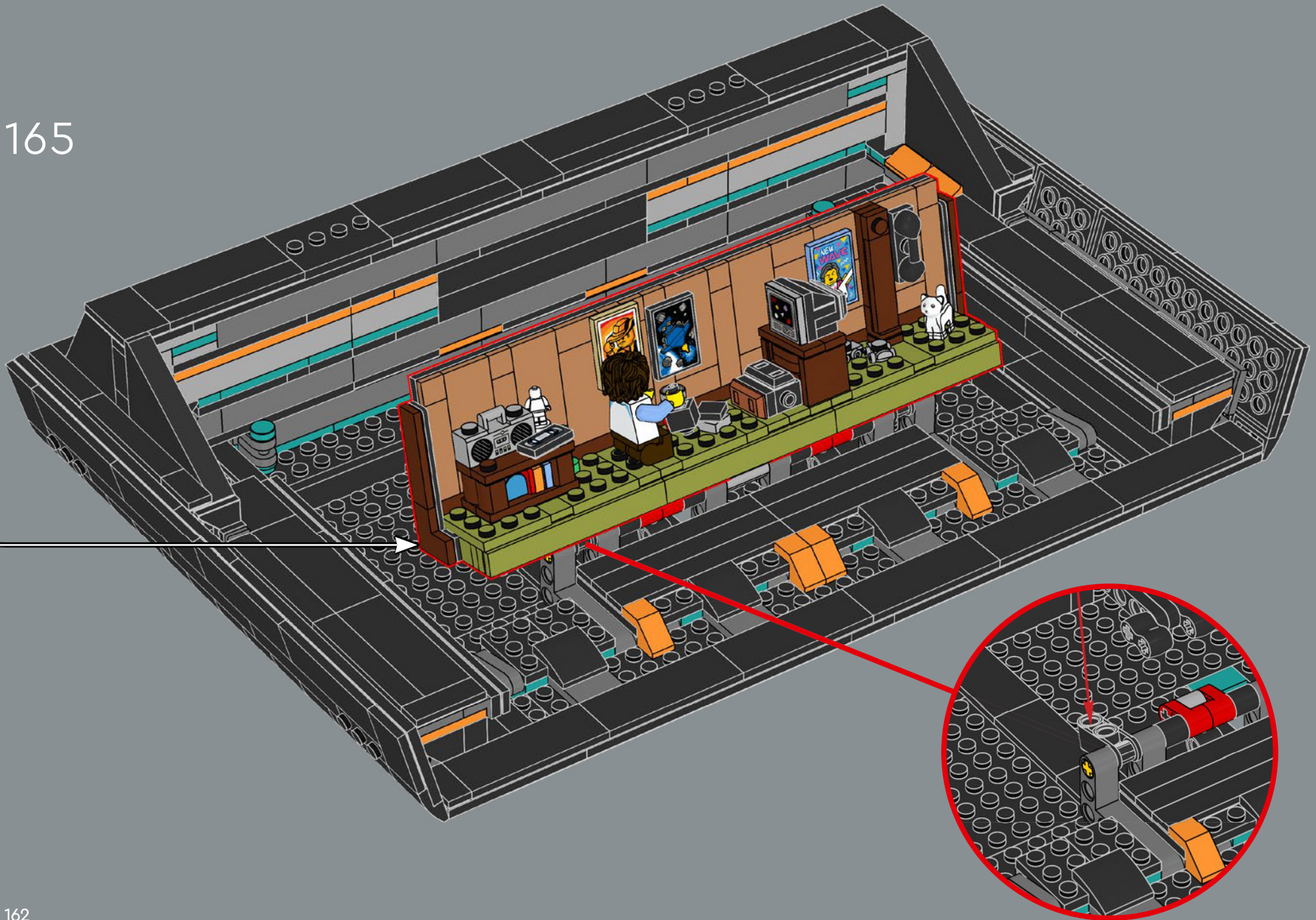

162

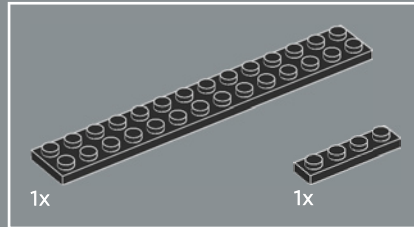
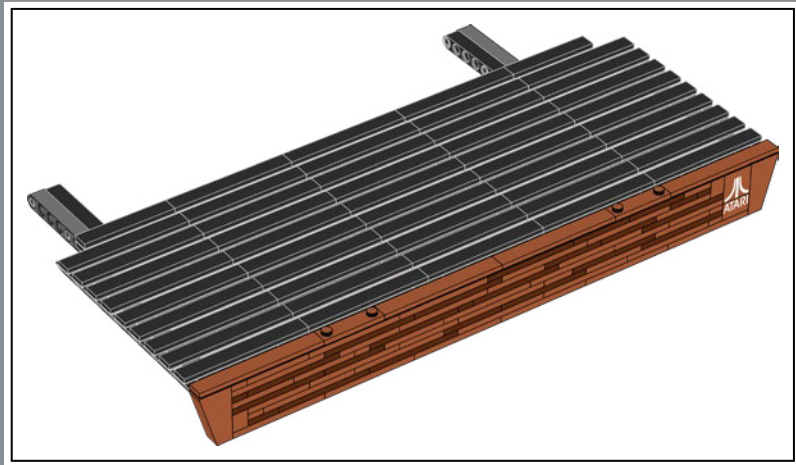
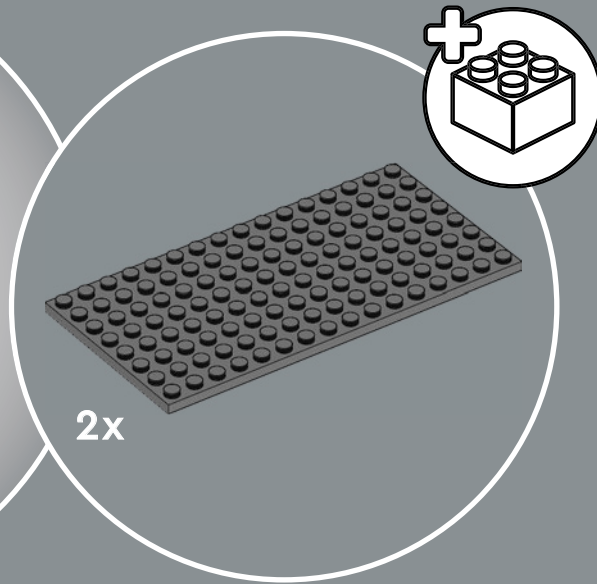

166

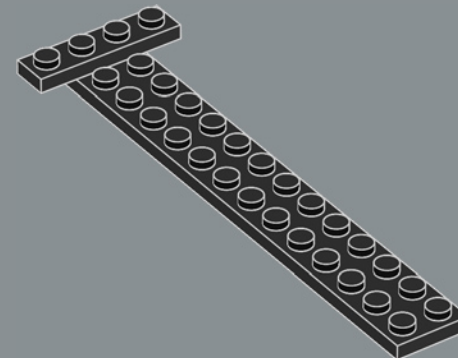

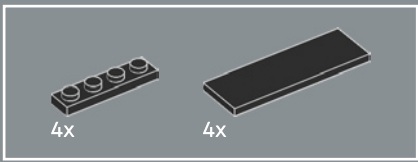

167

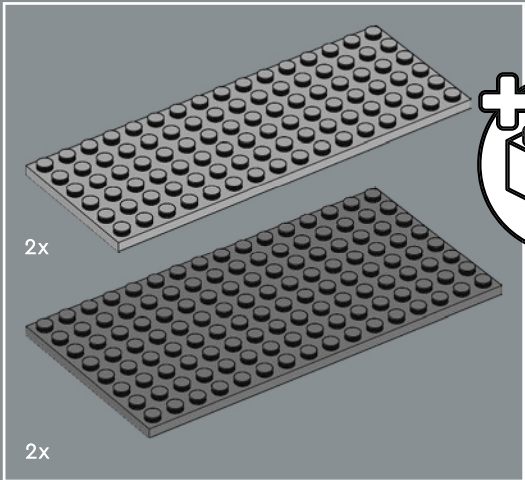
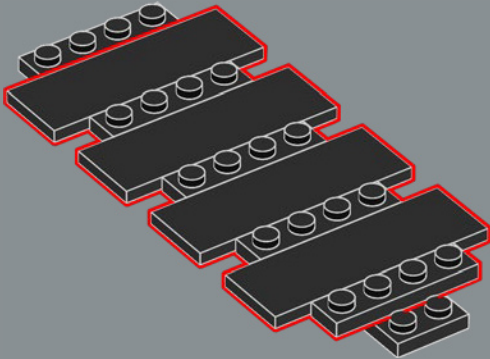

168

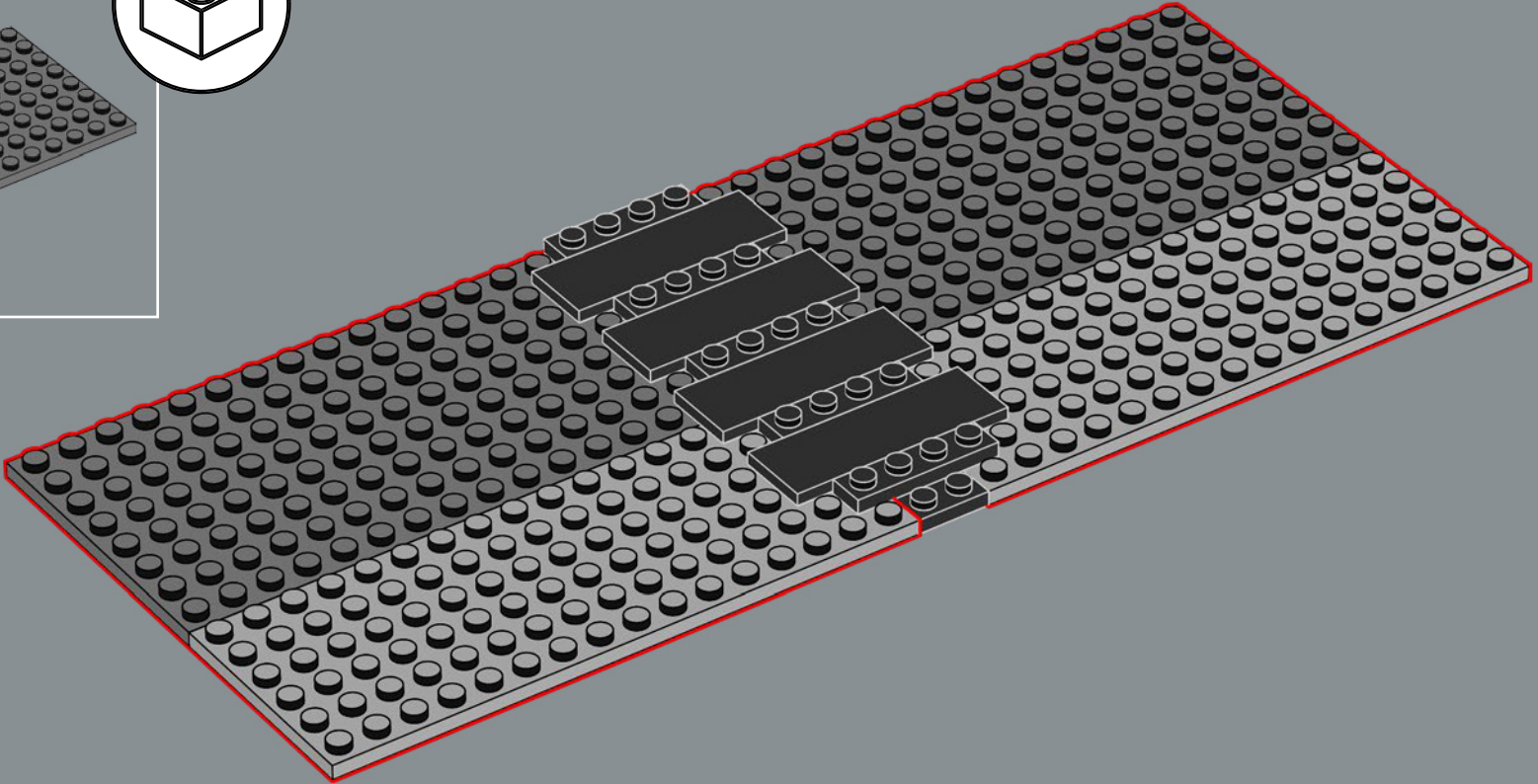

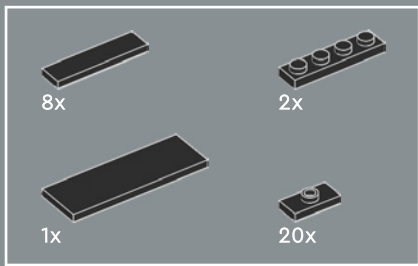

169

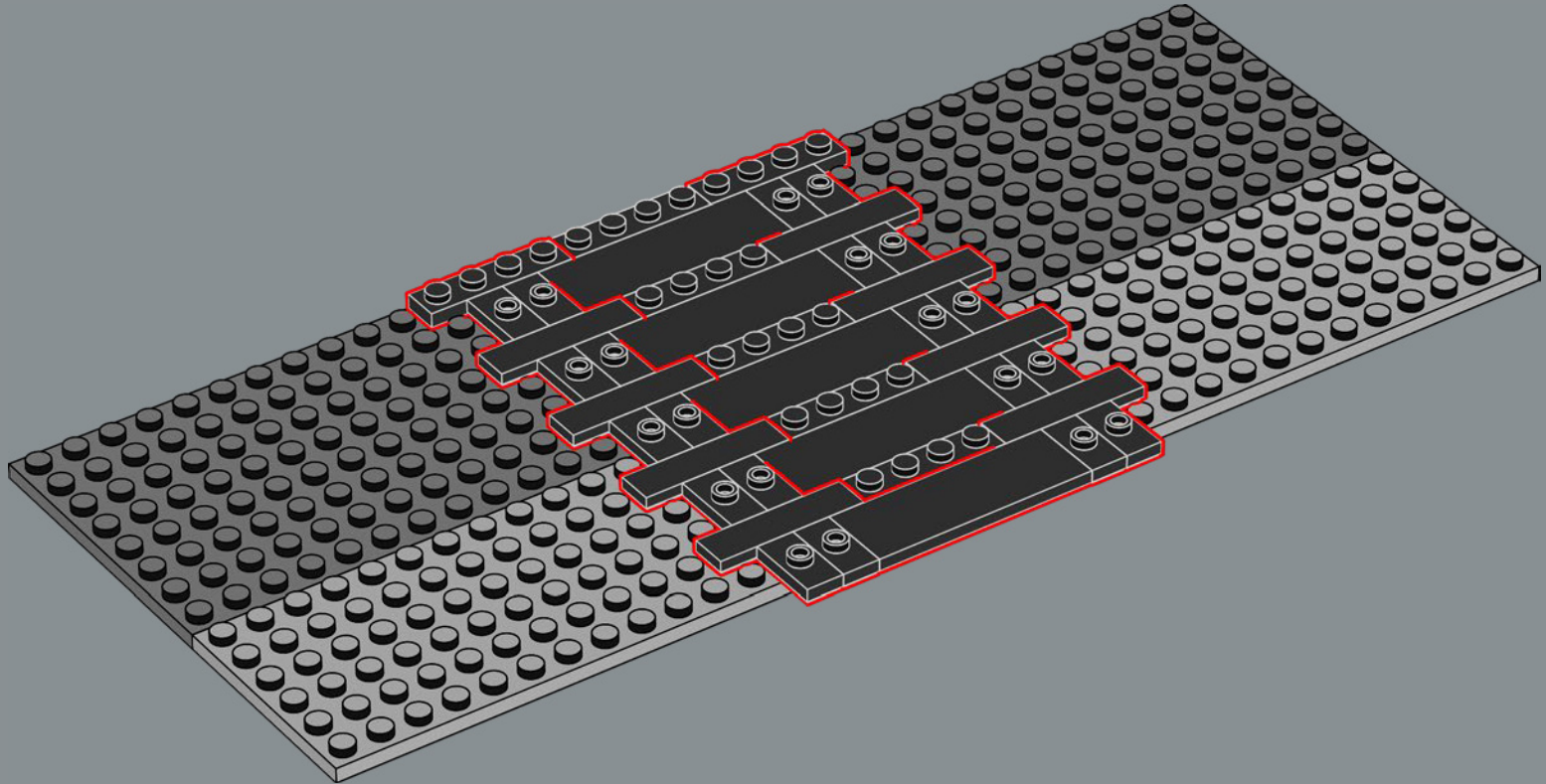

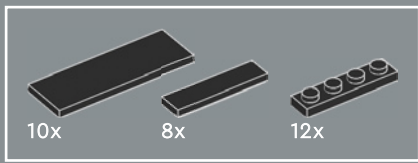

170

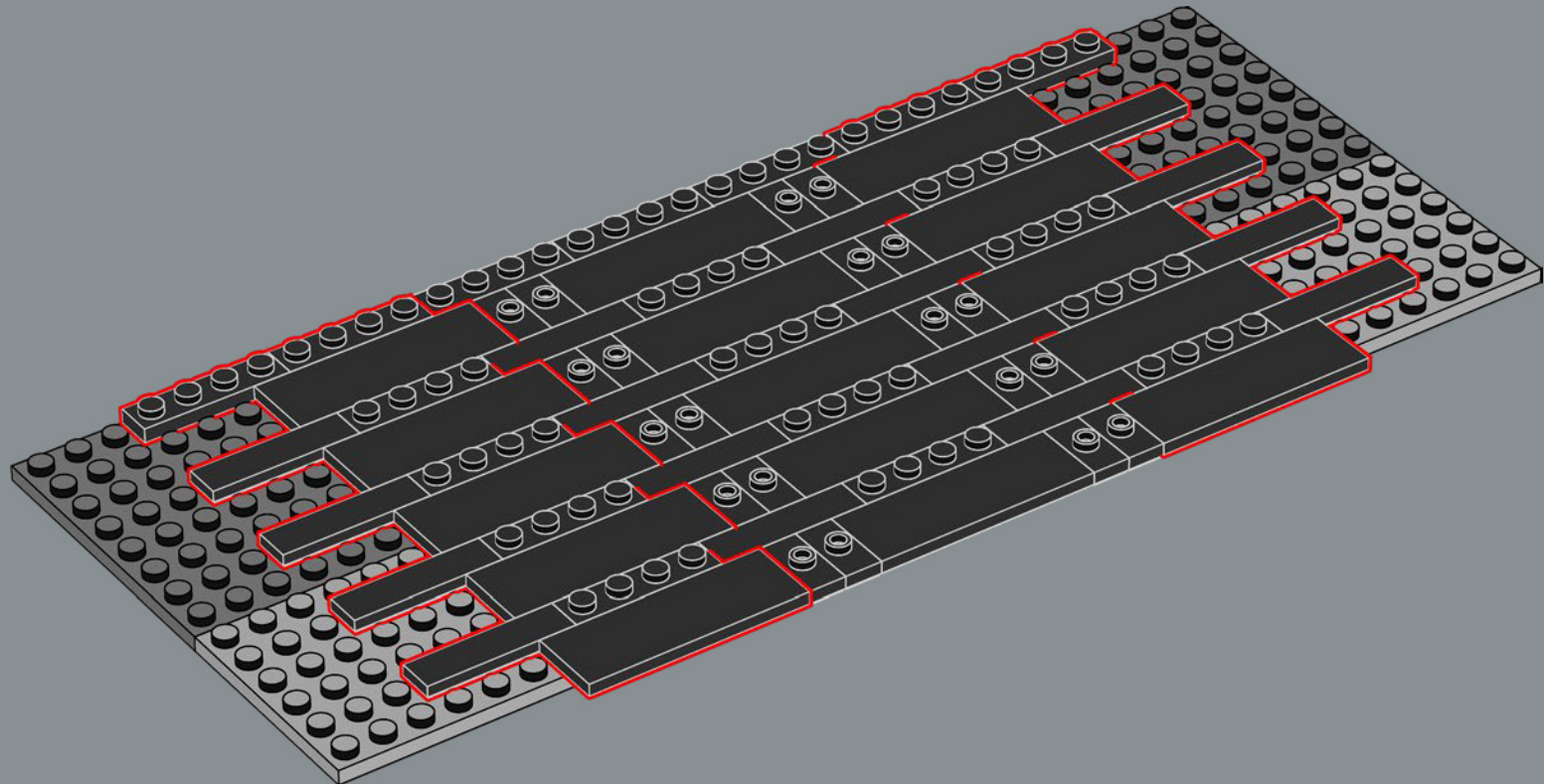



171

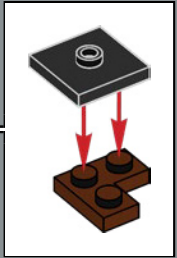
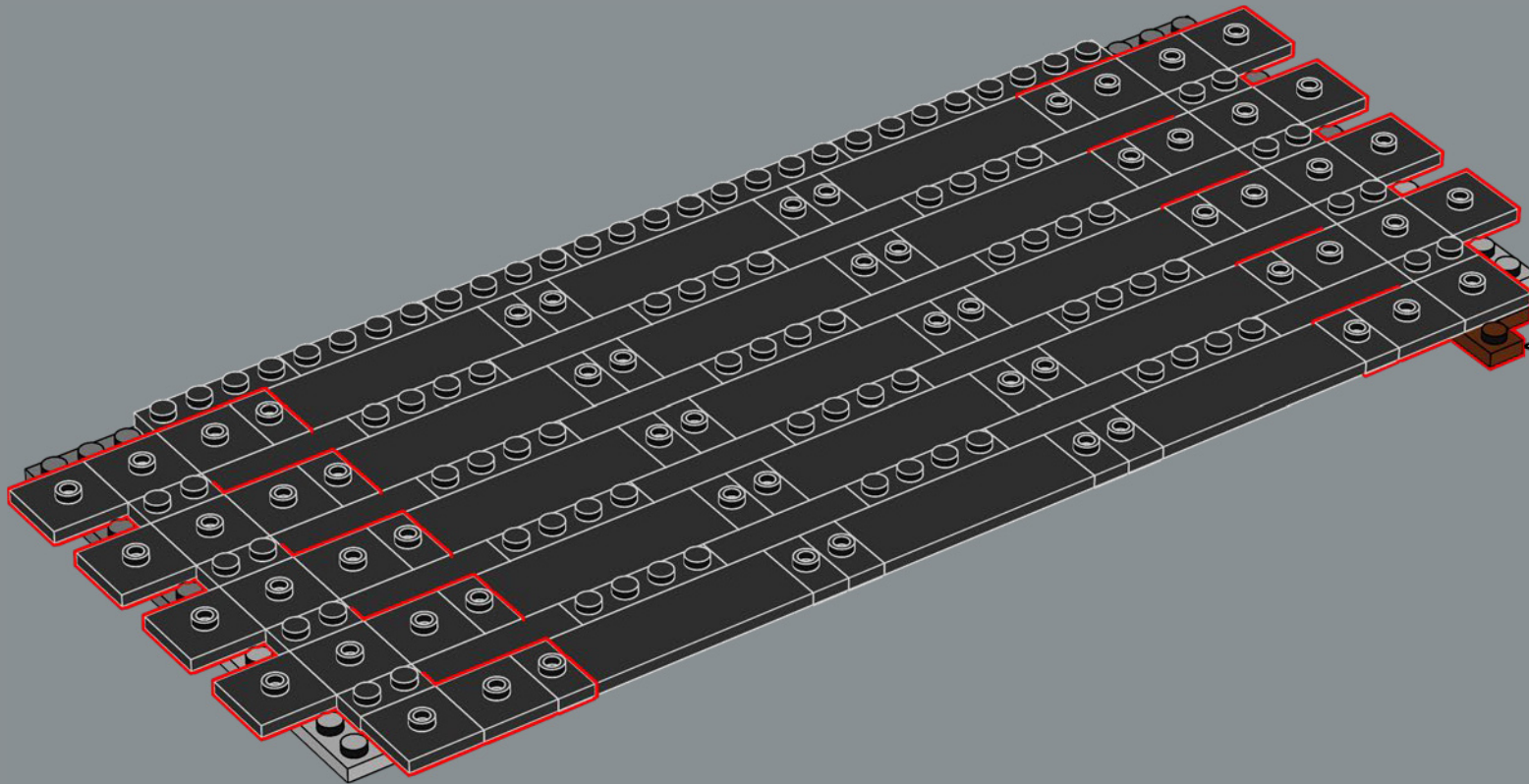

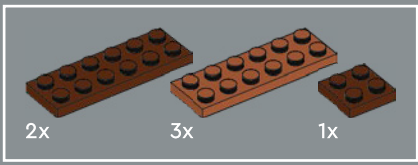

172

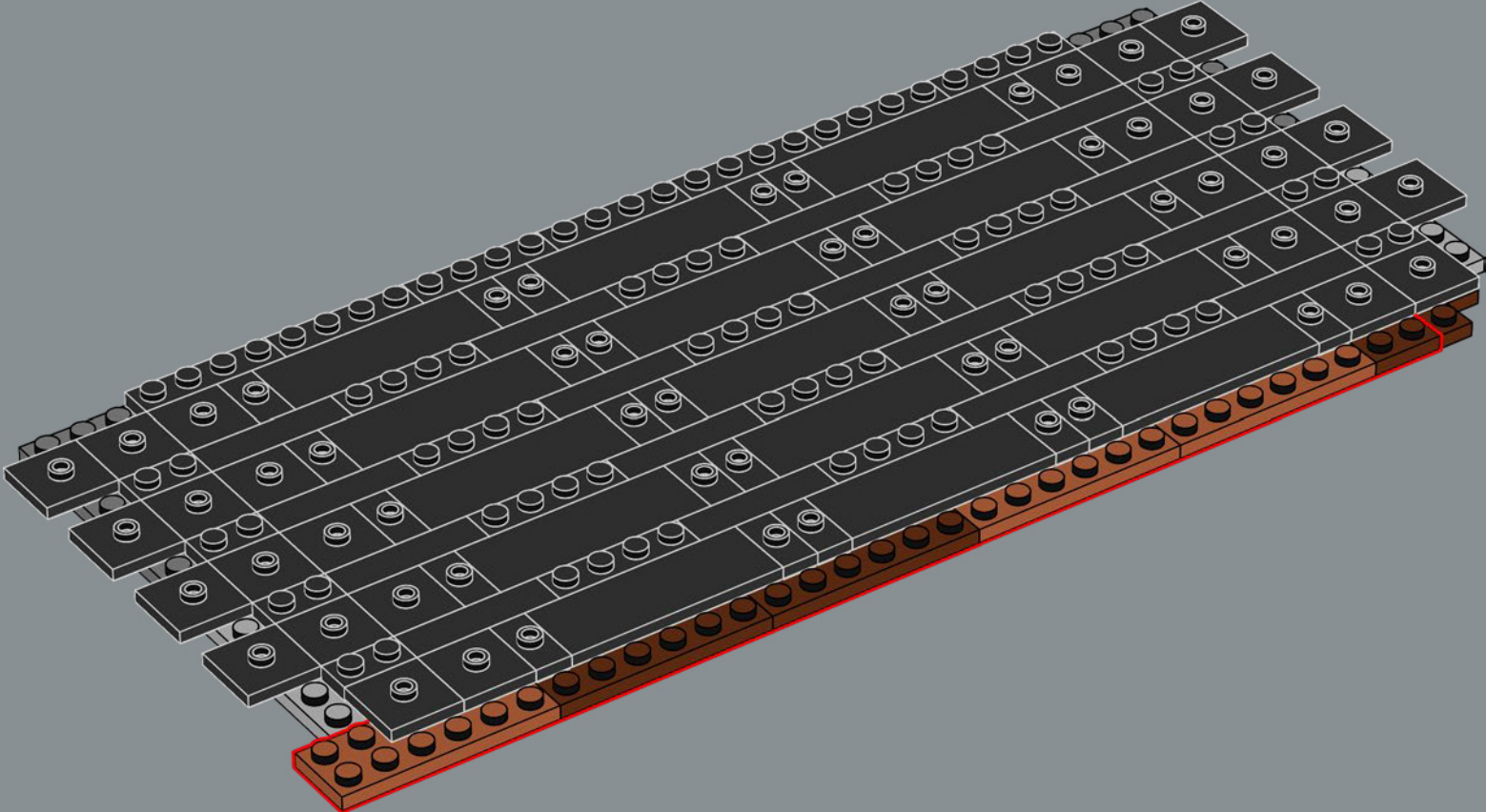

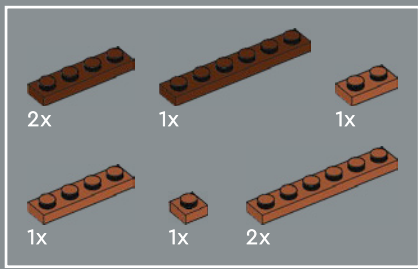

173

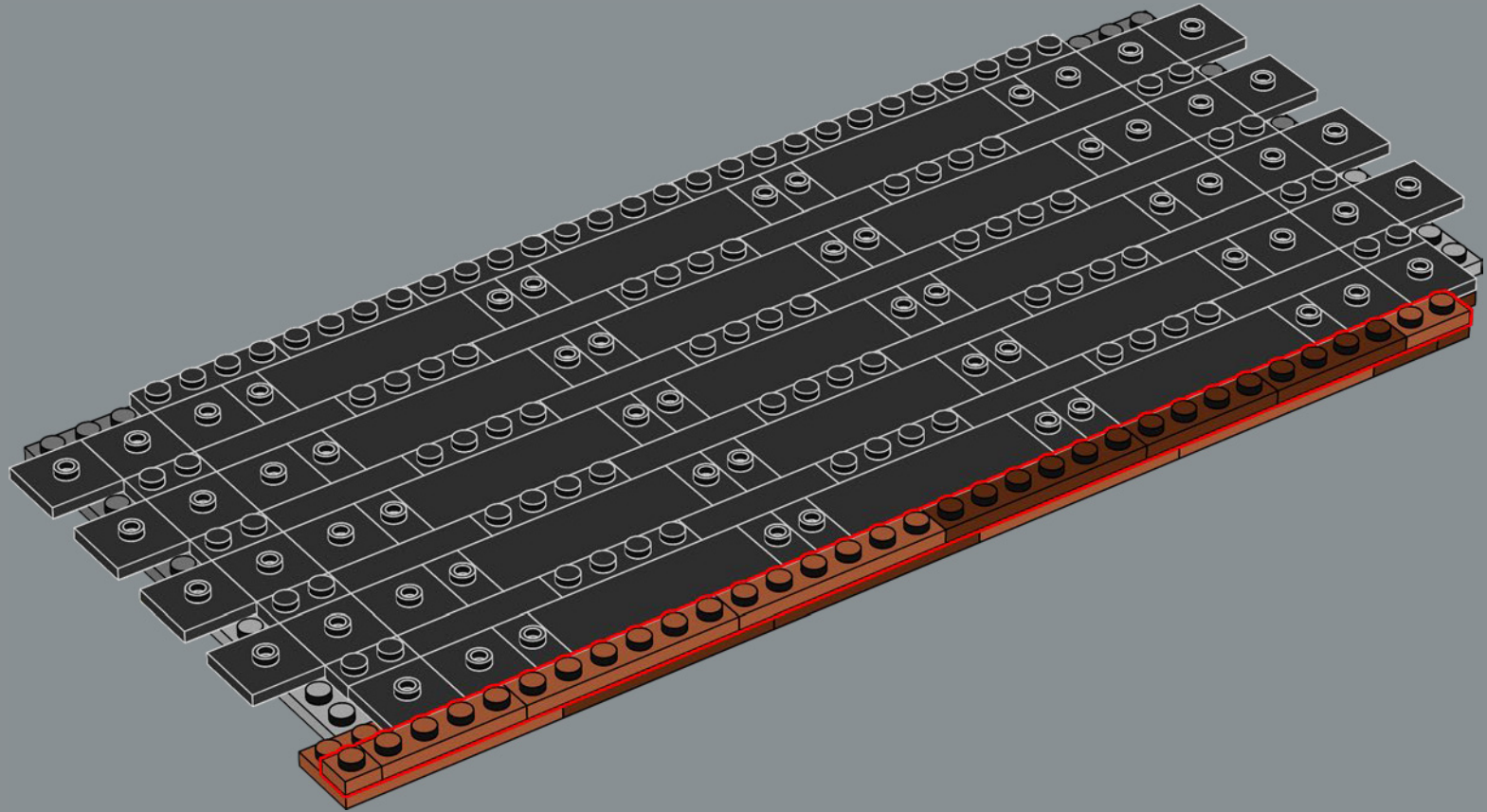

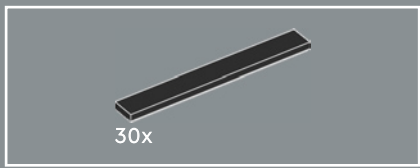

174

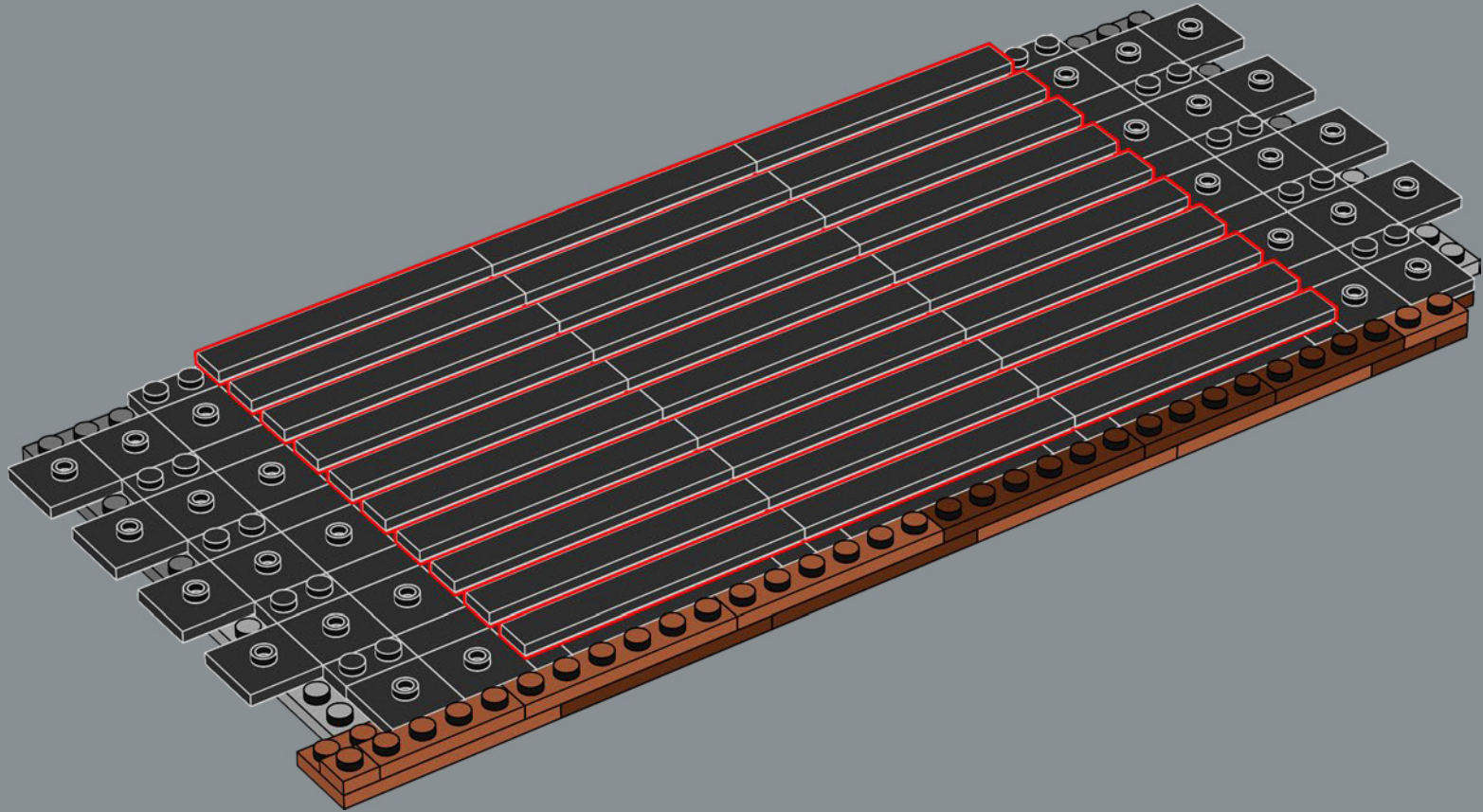

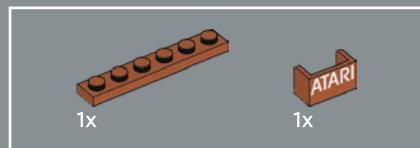
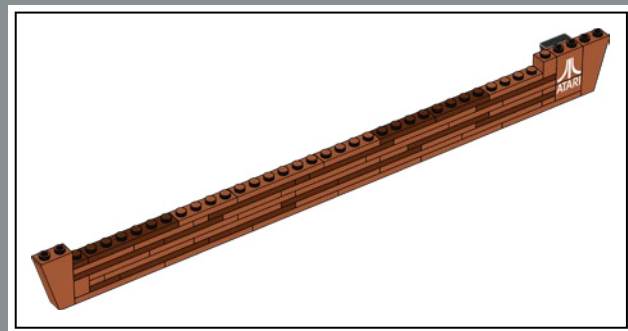

175

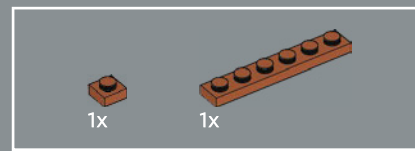
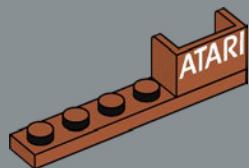

176

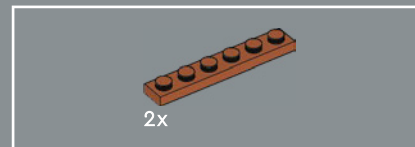
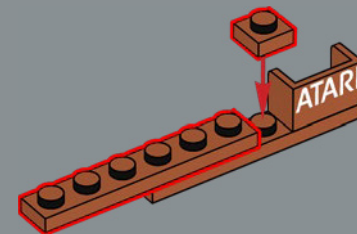

177

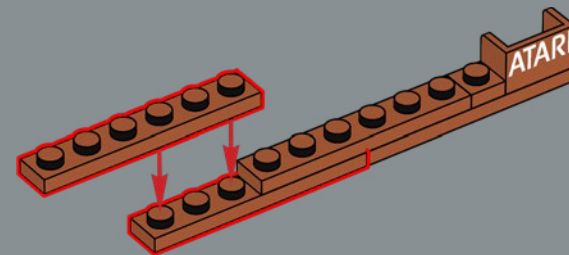

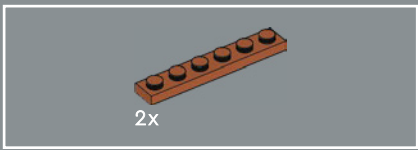

178

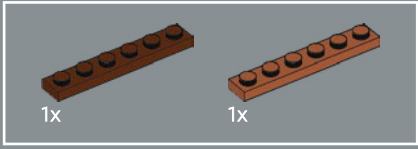
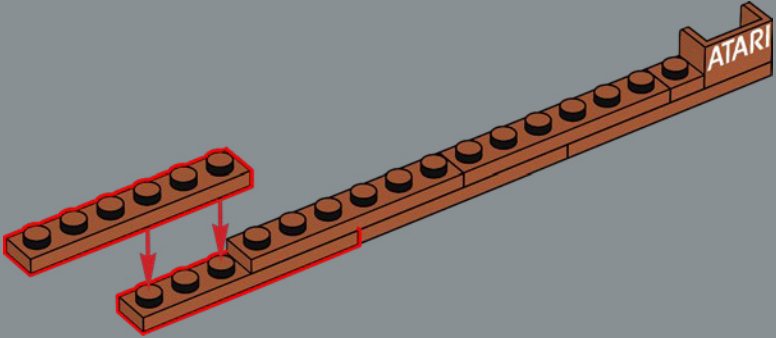

179

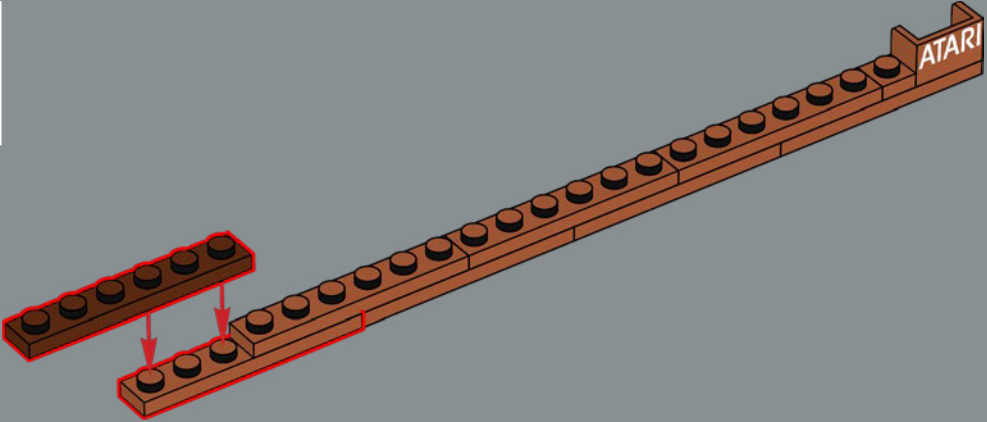

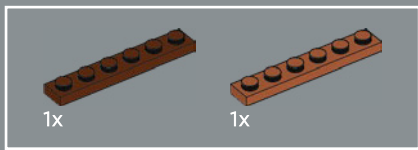

180

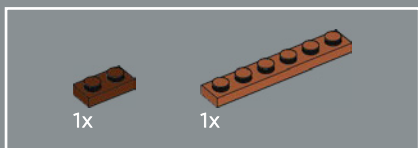
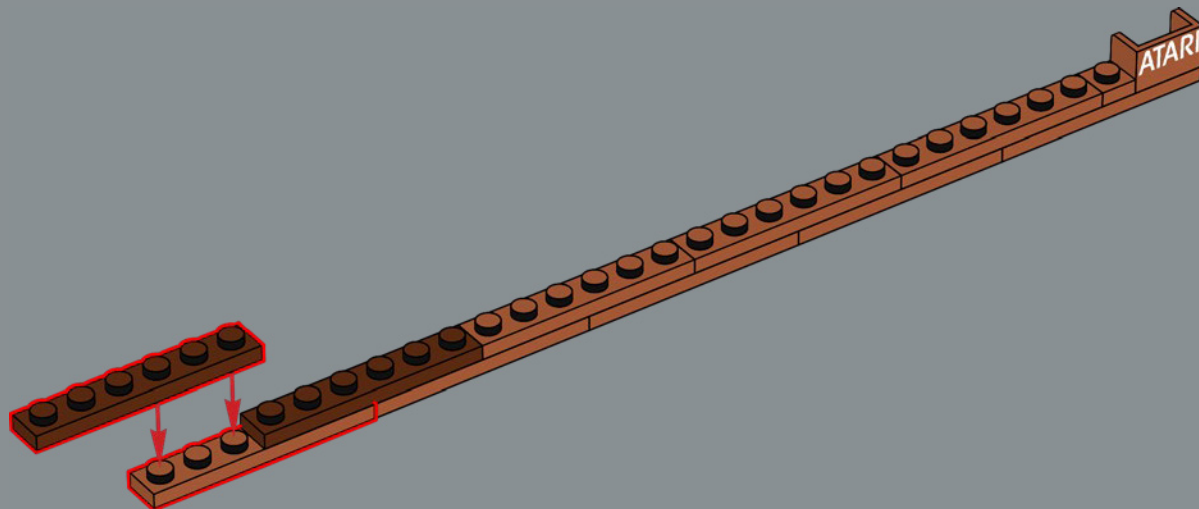

181

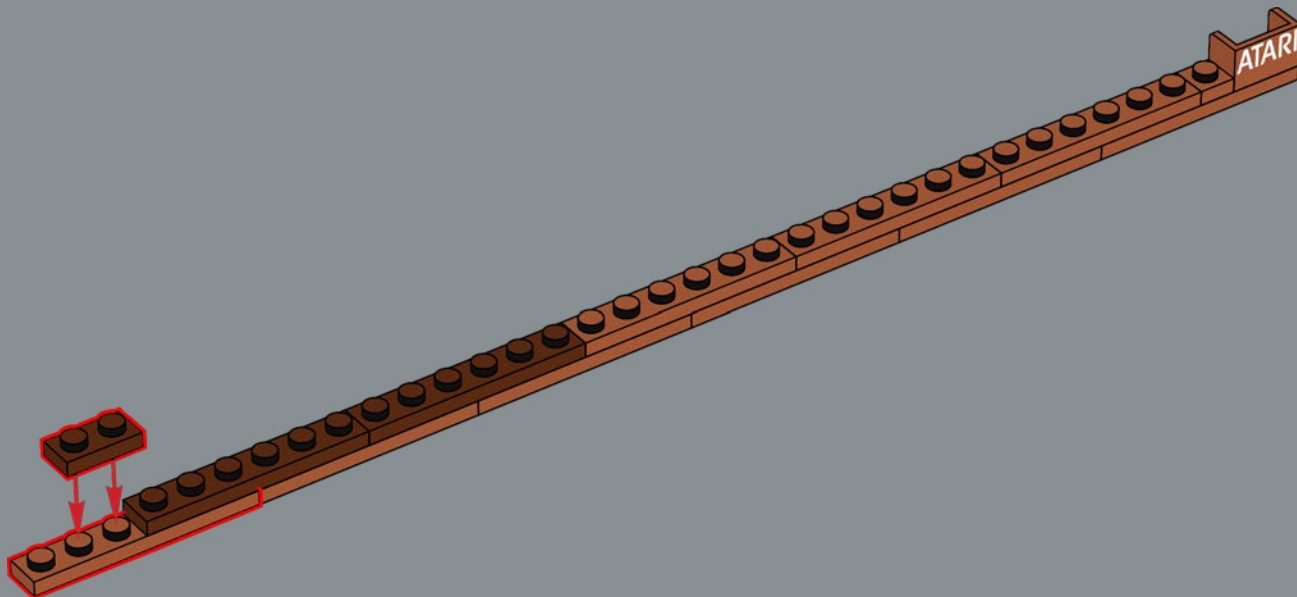

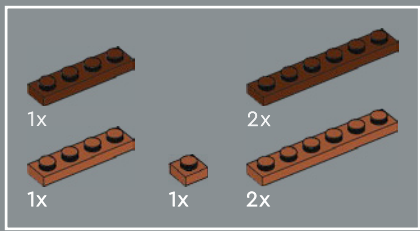

182

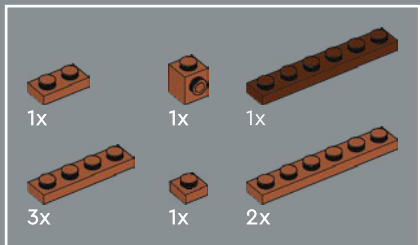
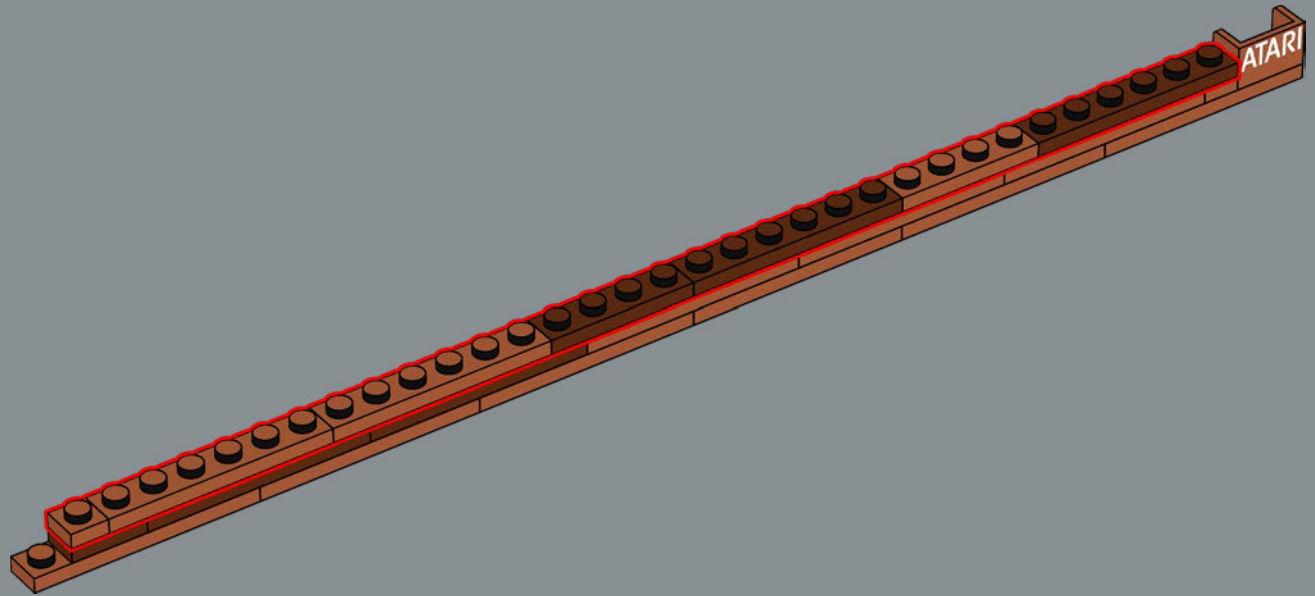

183

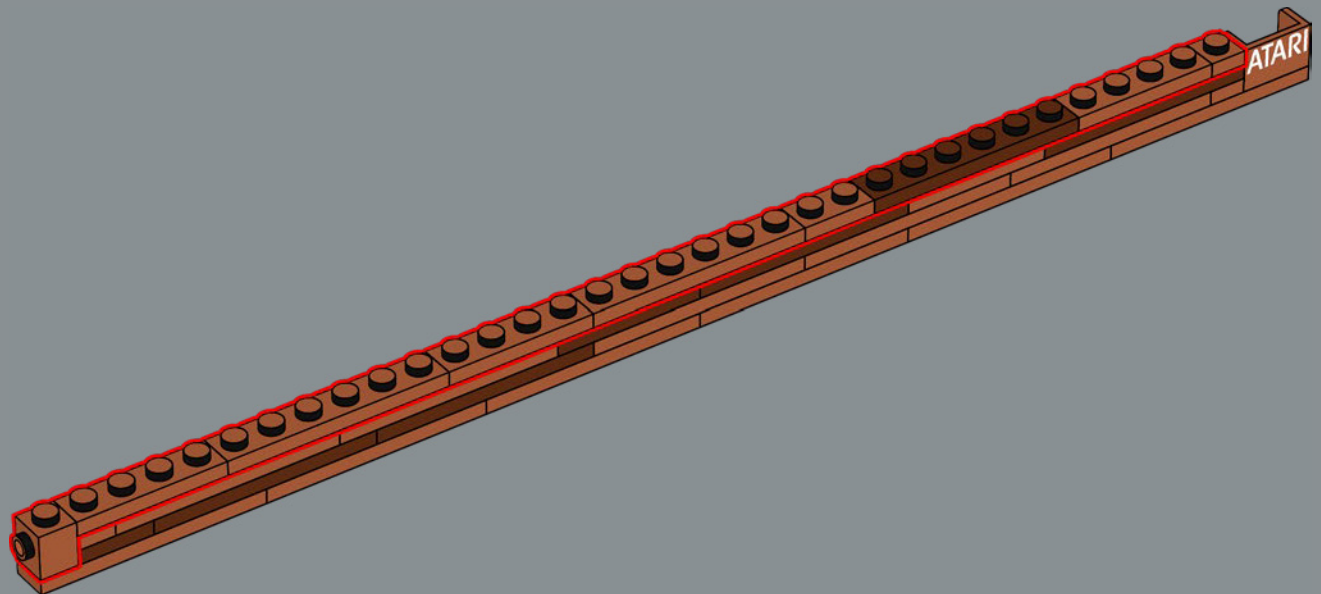

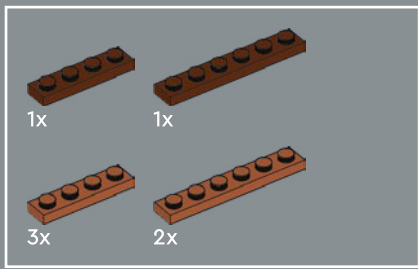

184

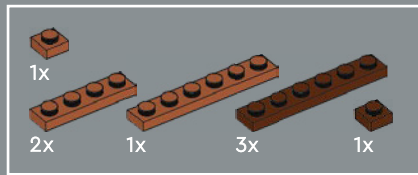
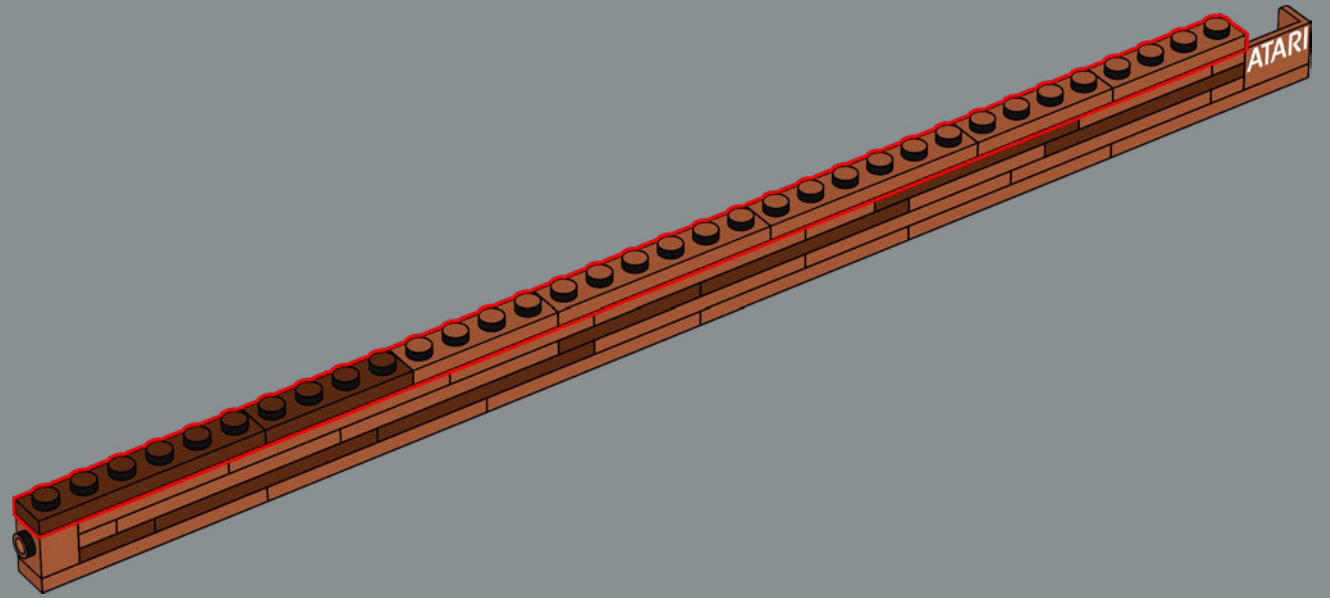

185

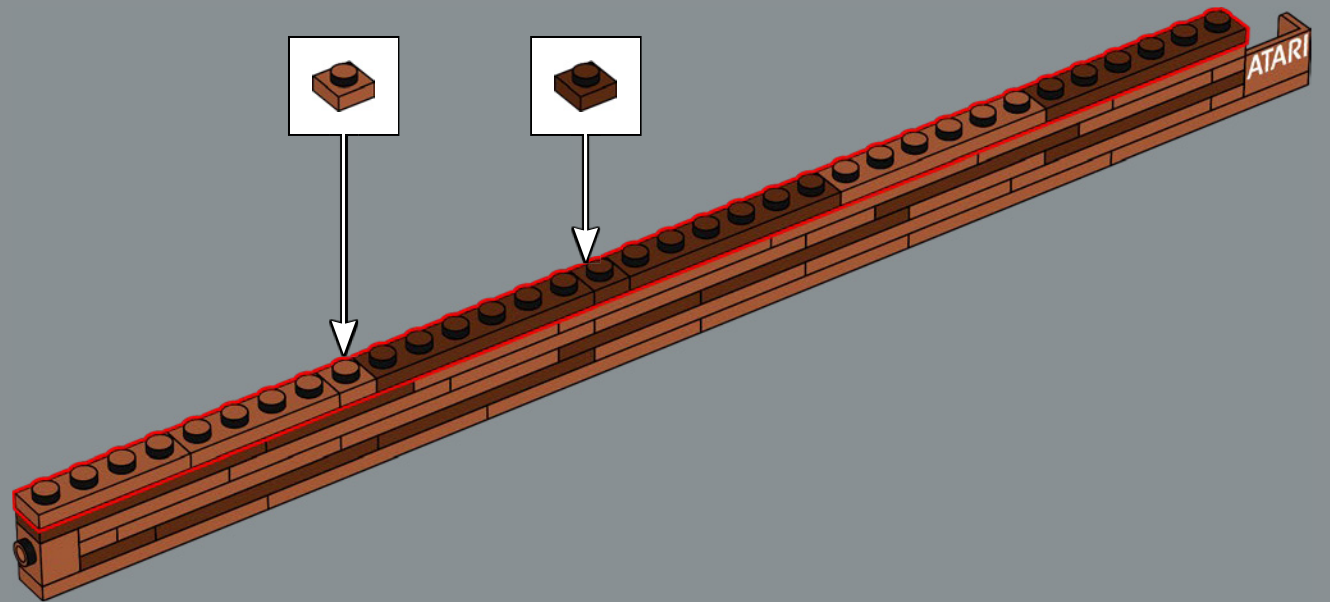

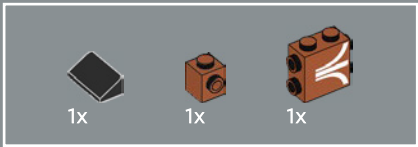

186

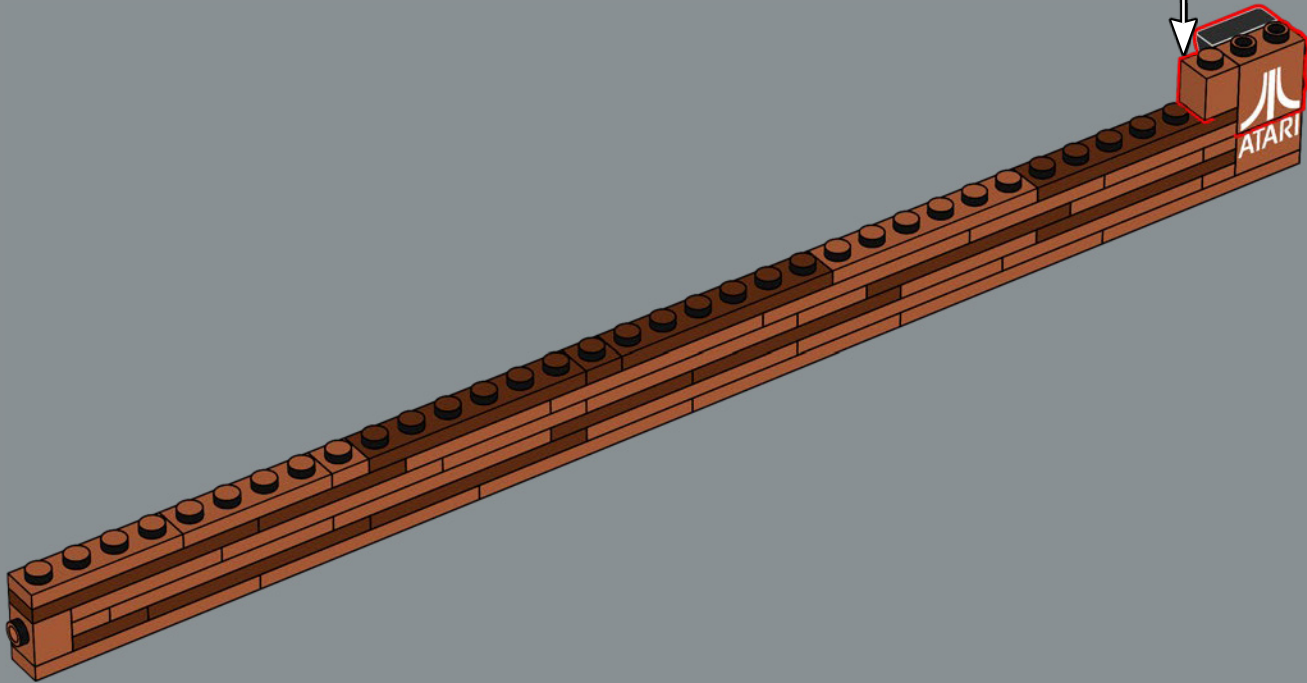
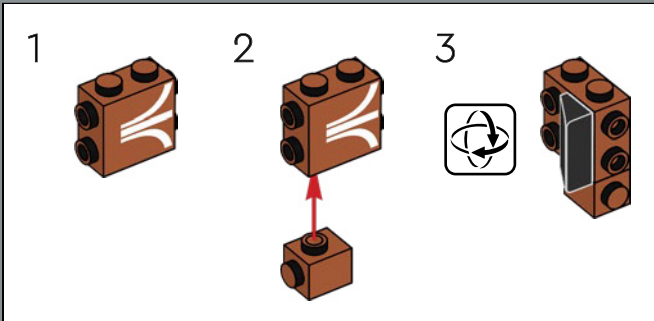

ATARI® was incorporated as a company on June 27, 1972.

La société ATARI® a été constituée le 27 juin 1972.

ATARI® se constituyó como empresa el 27 de junio de 1972.



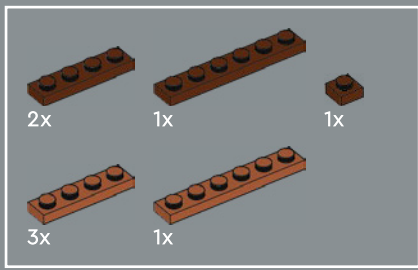

187

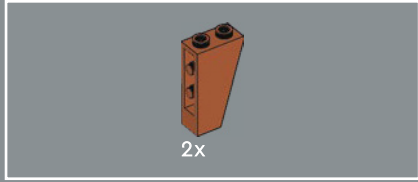
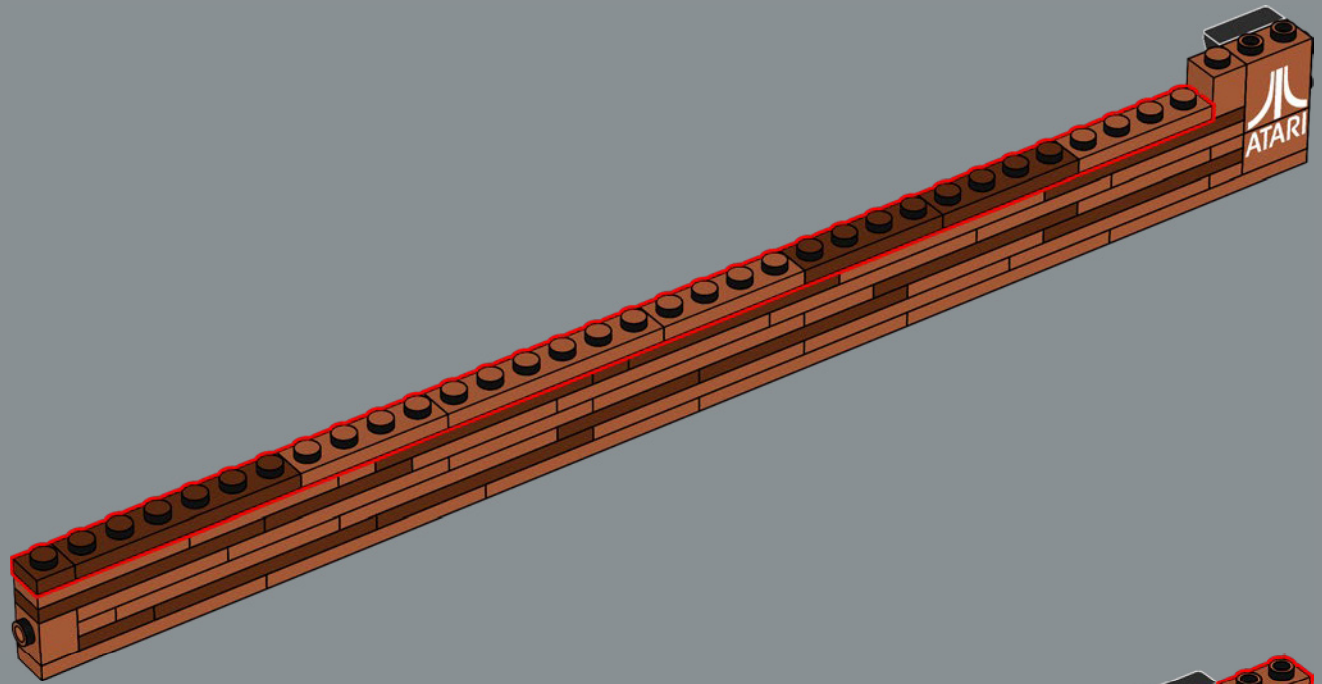

188

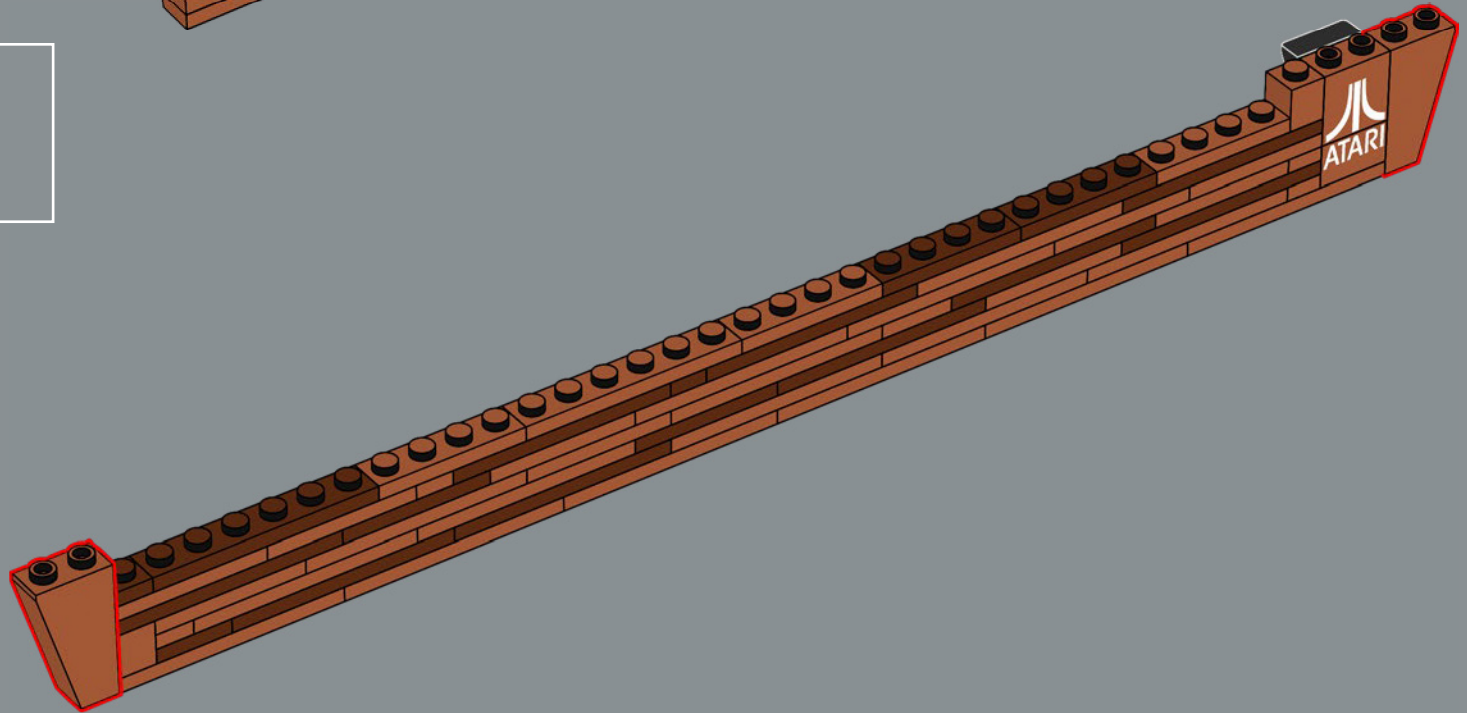

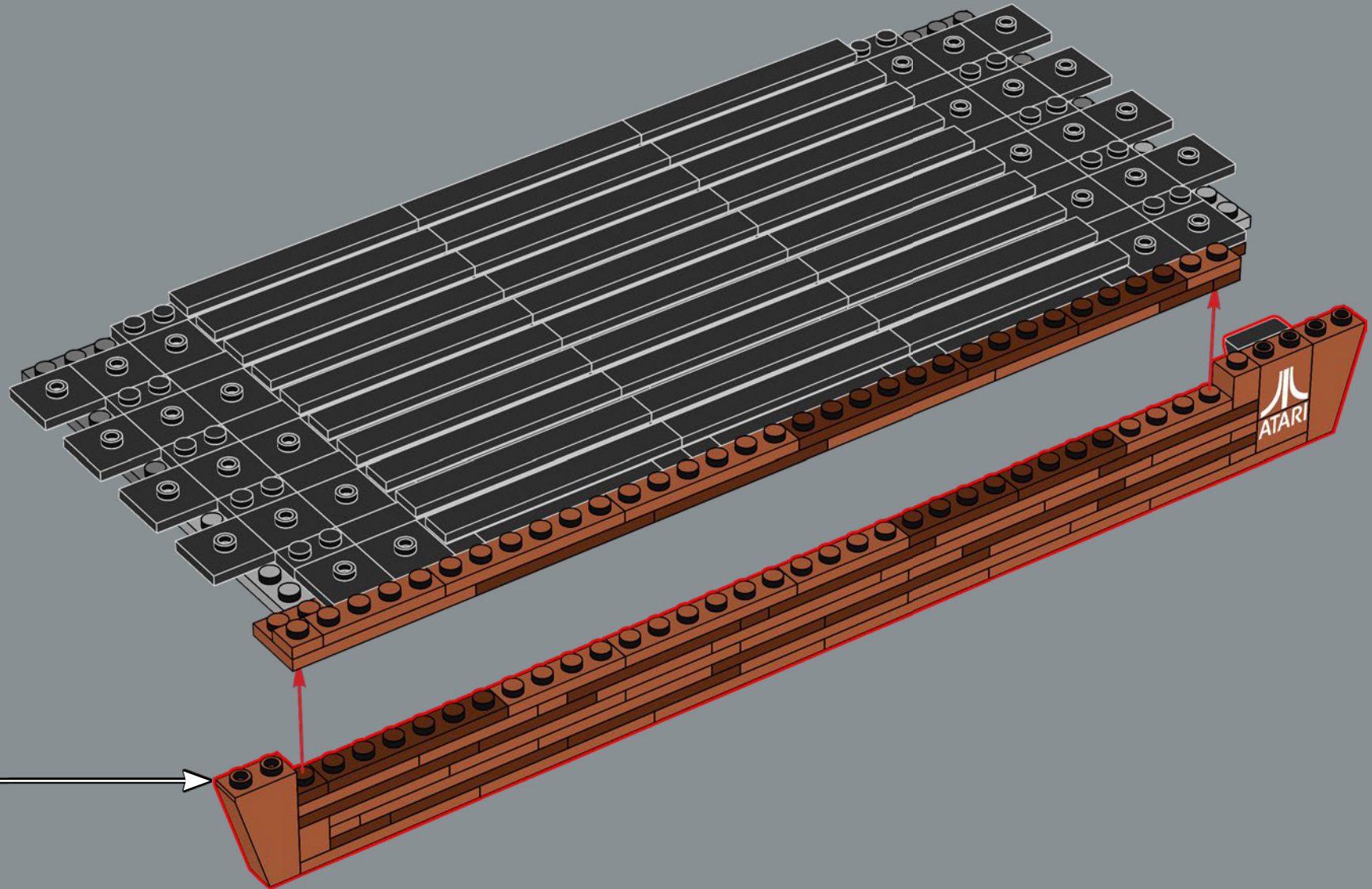

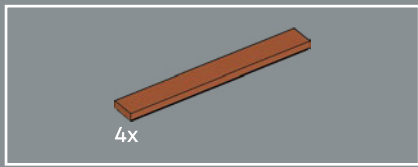

190

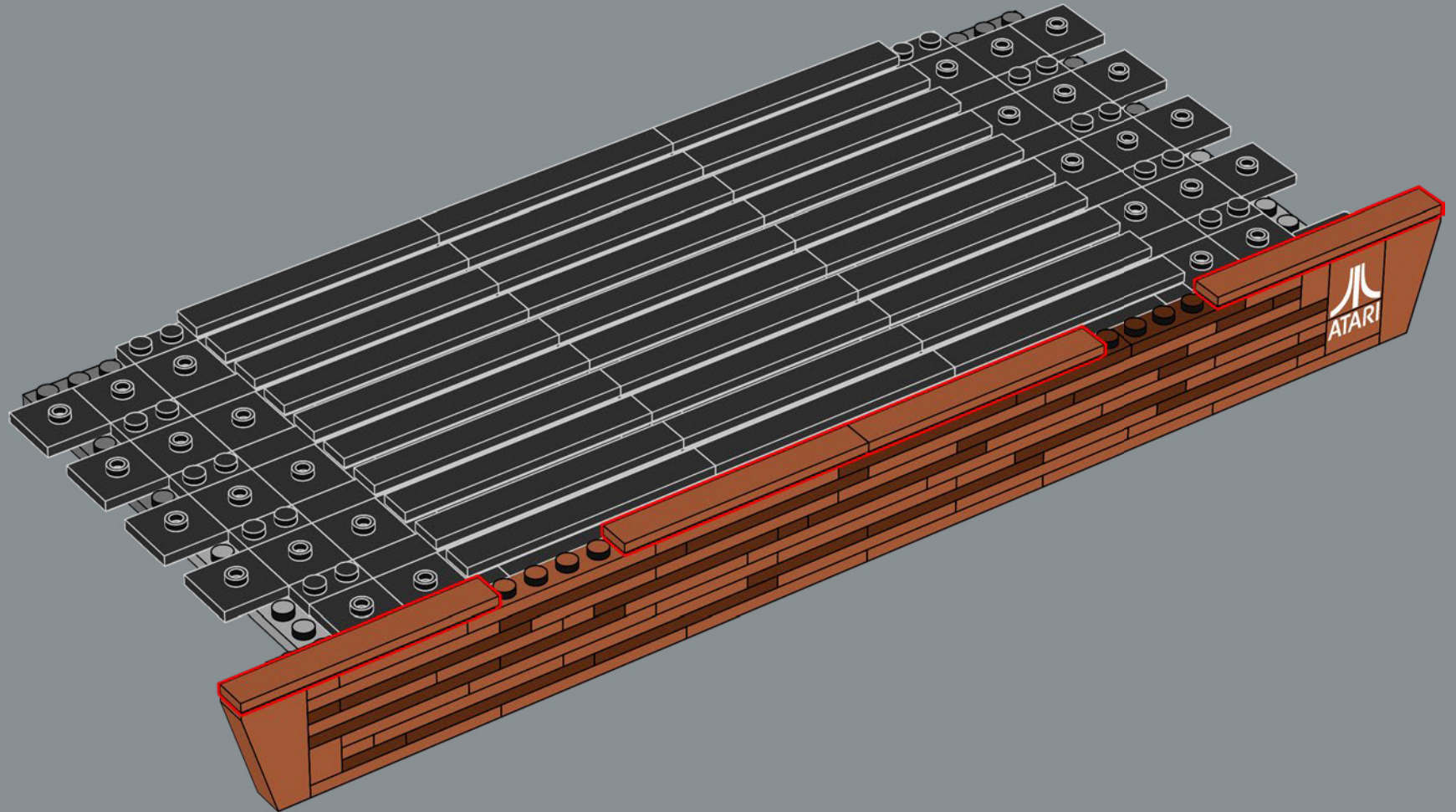

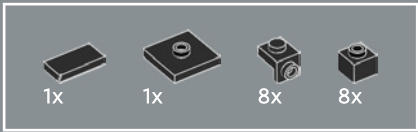

191

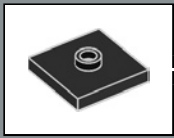
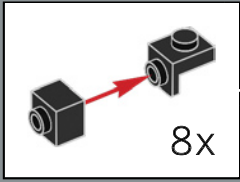
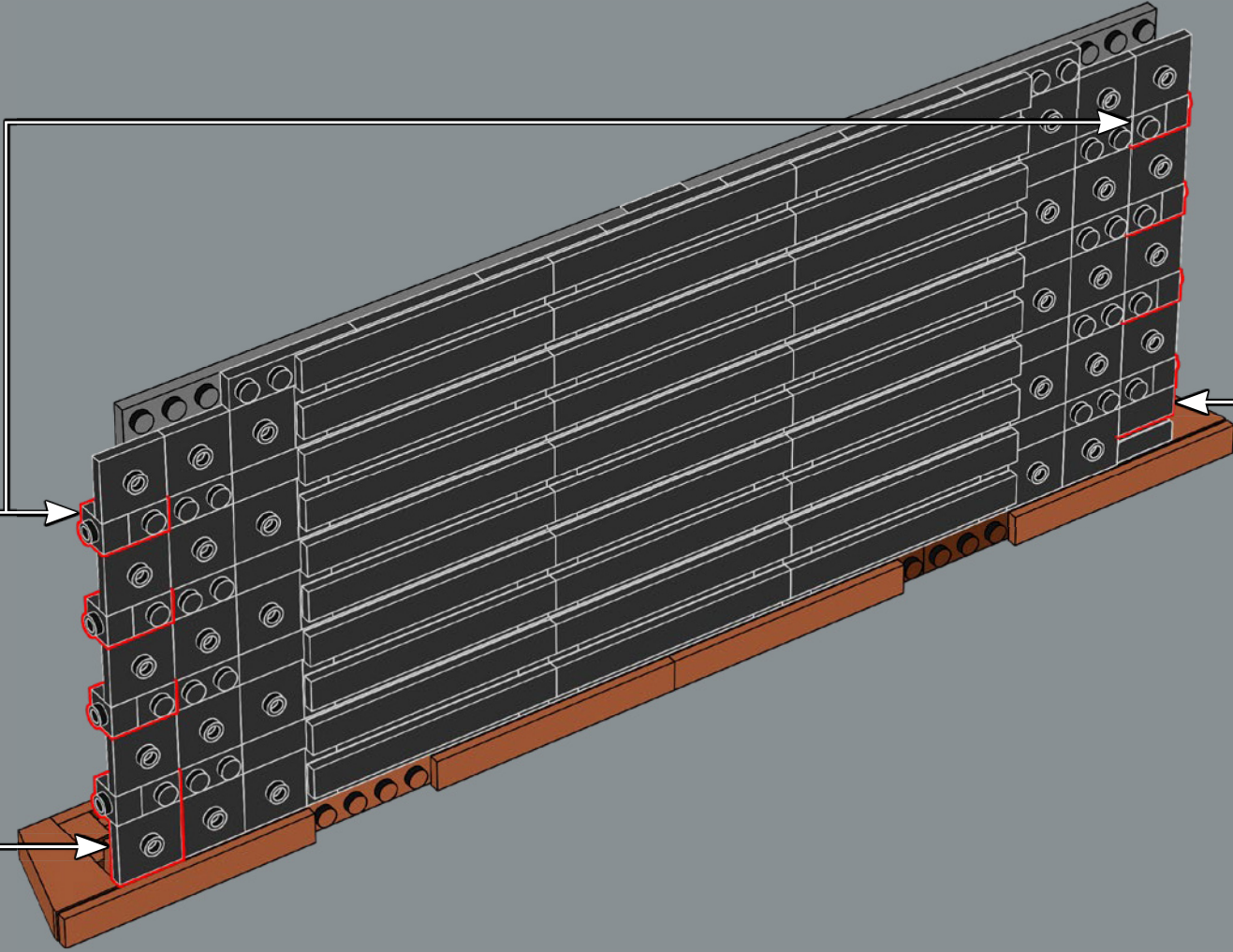

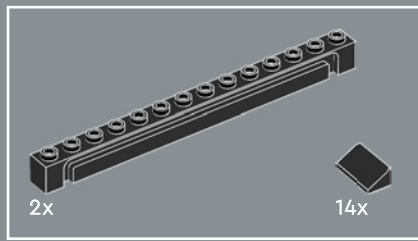

192

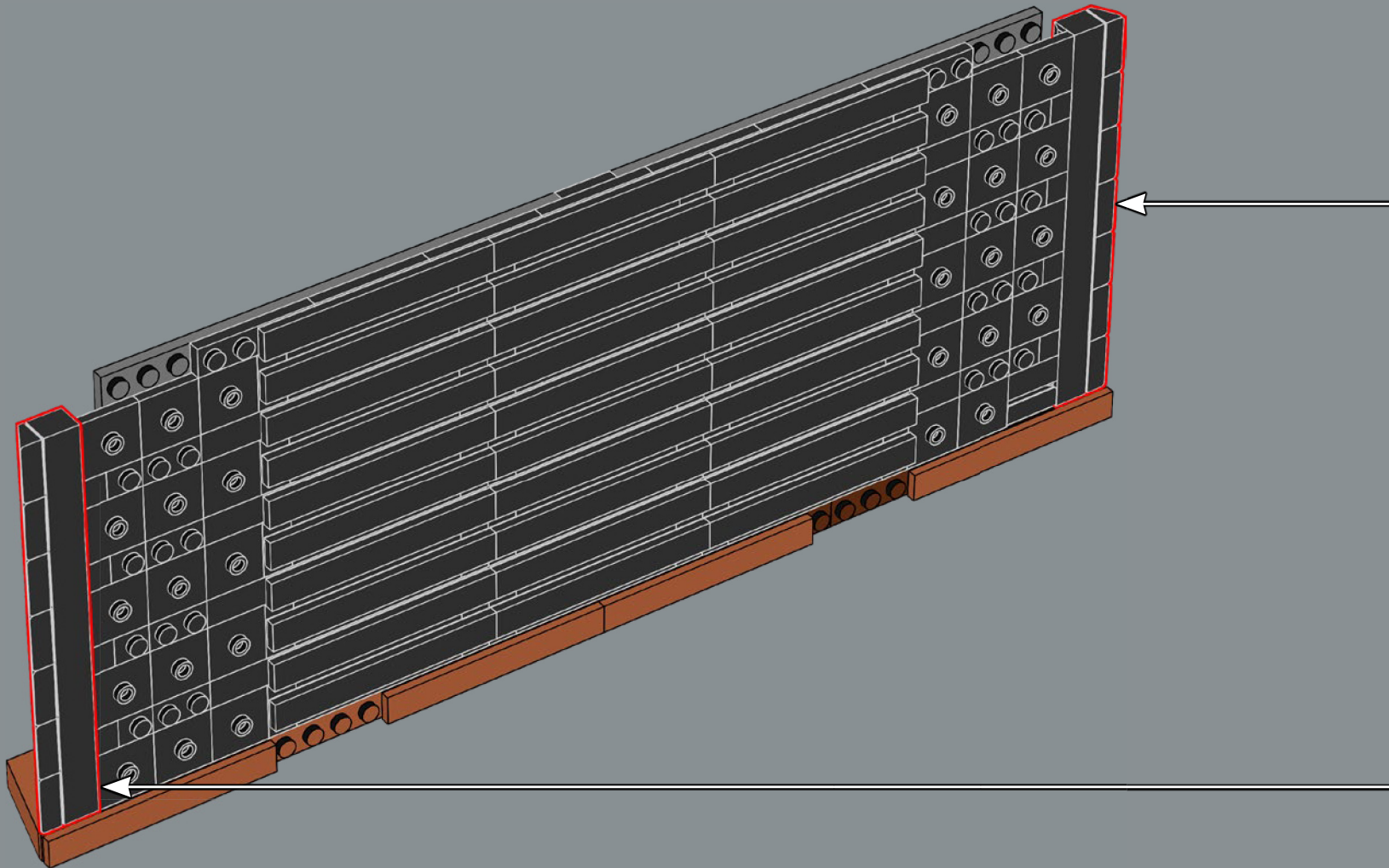
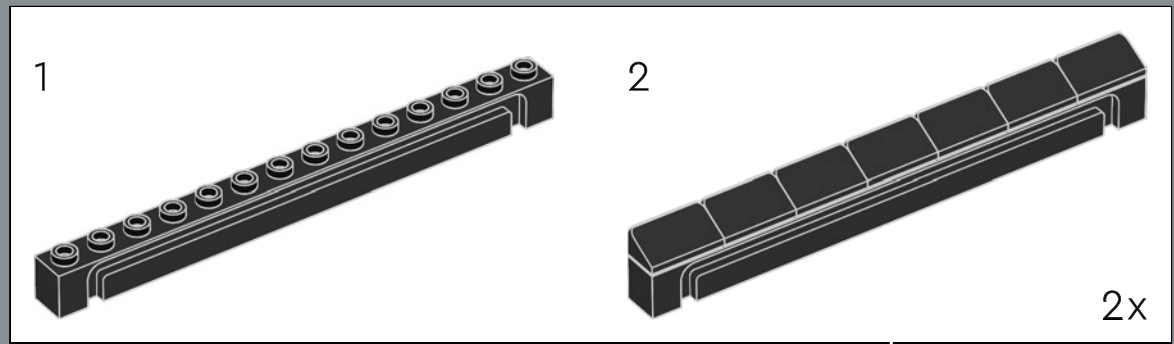

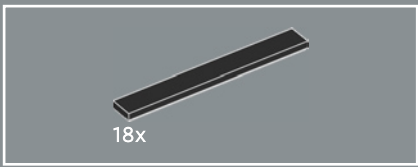

193

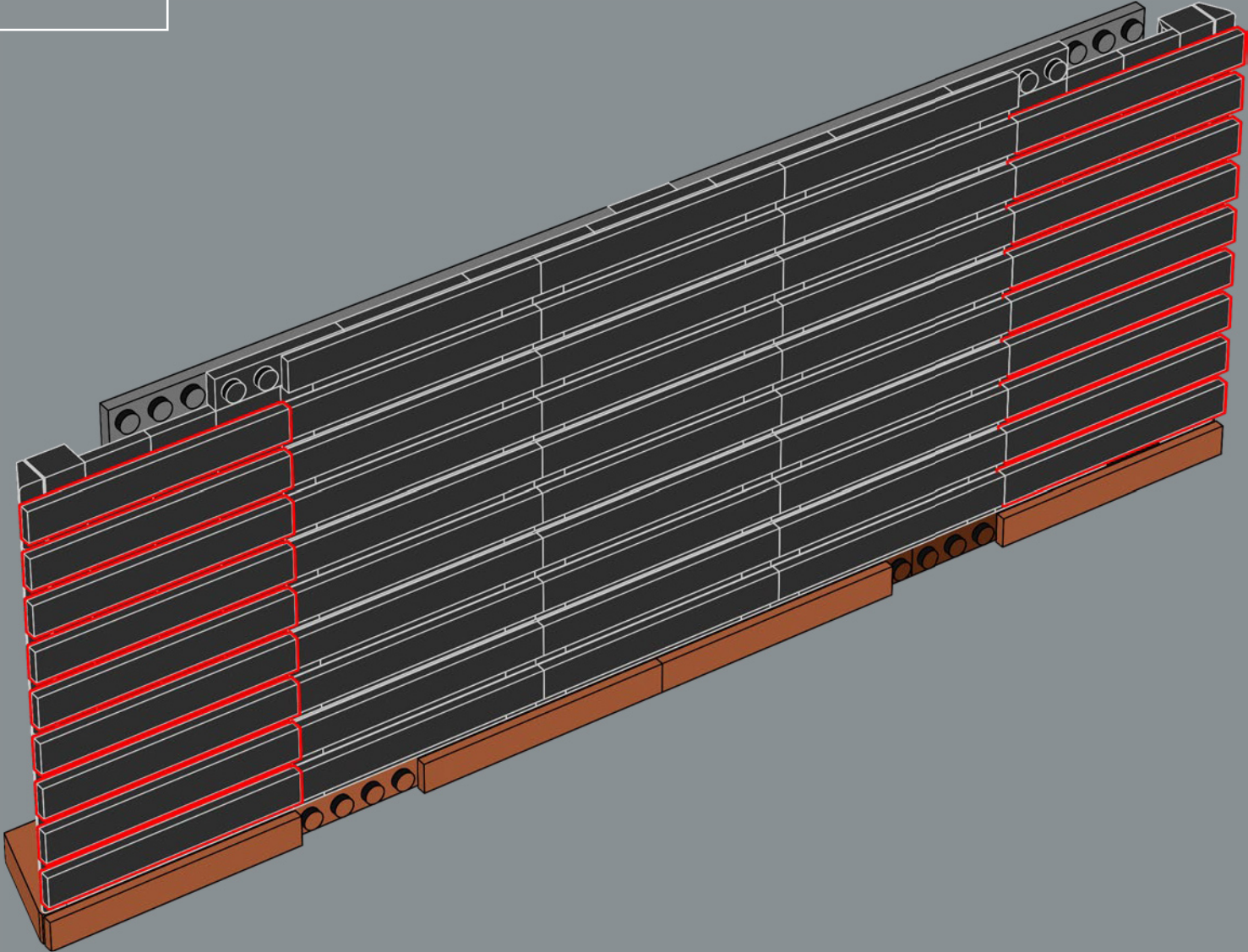



194

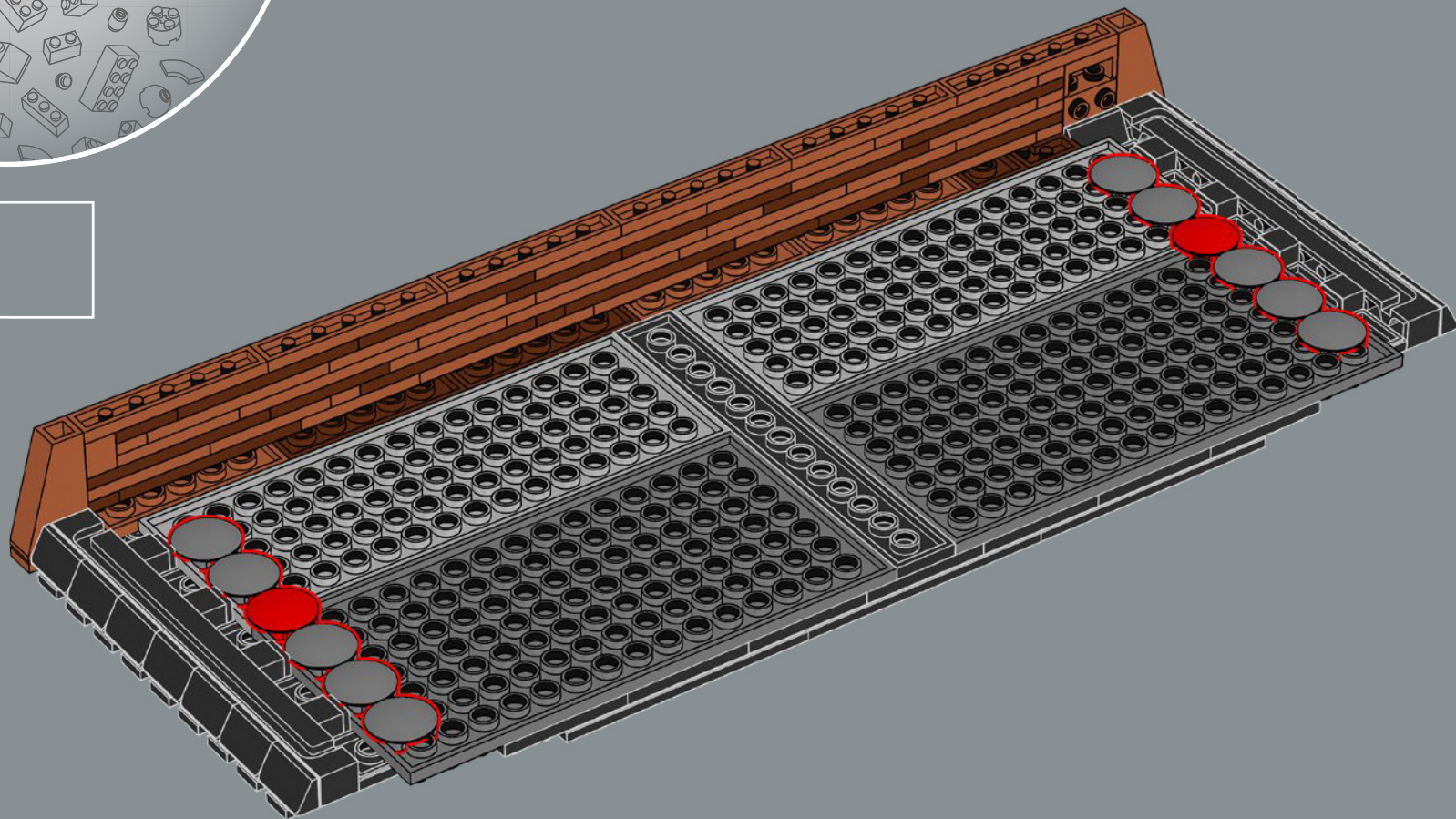

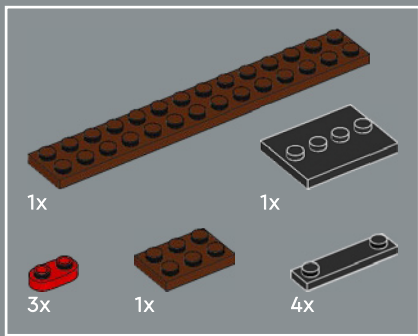

195

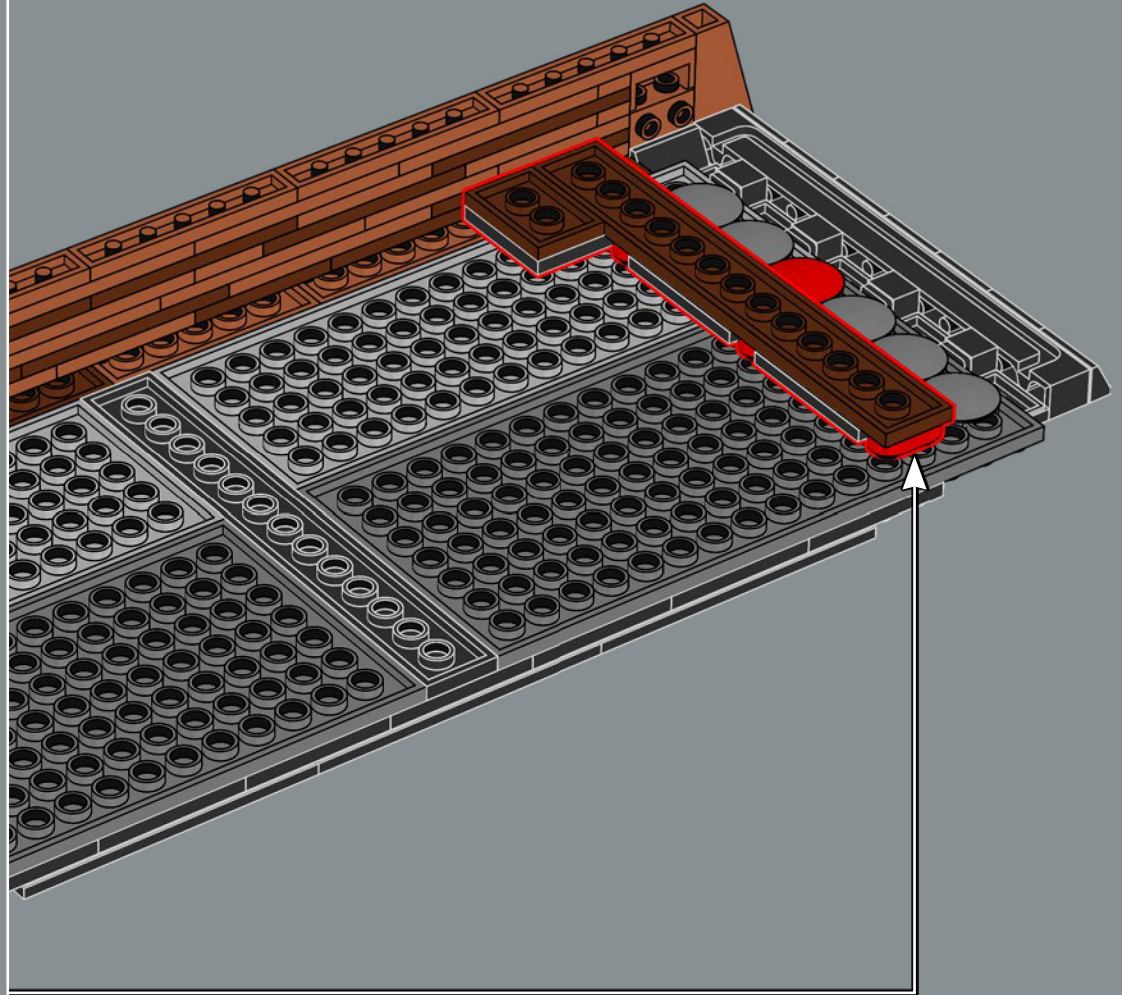
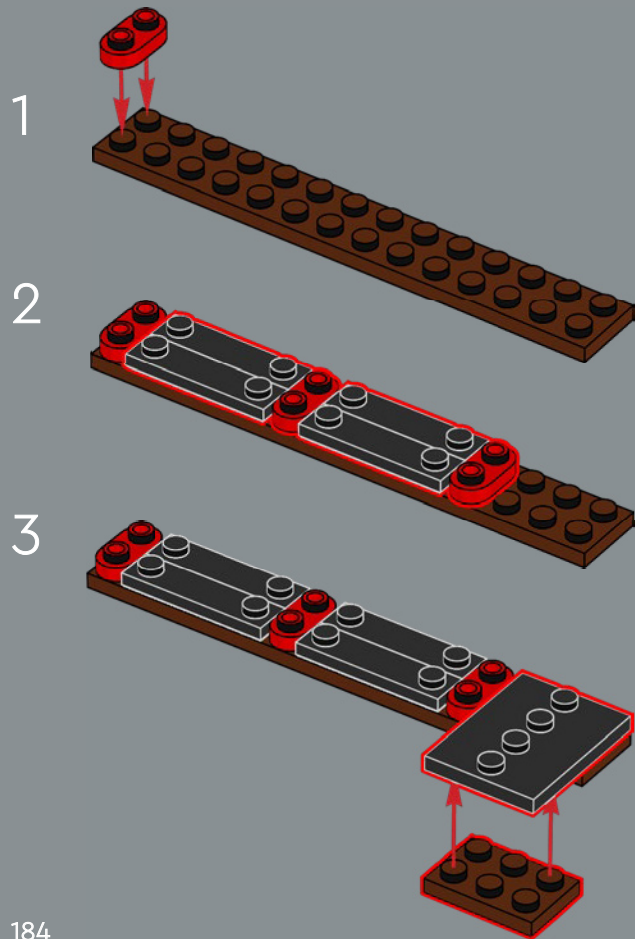

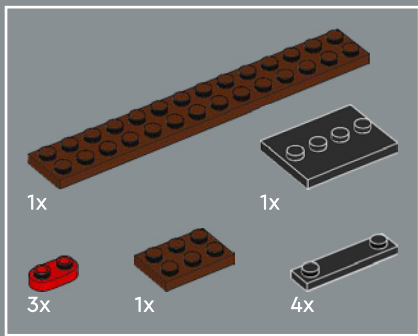

196

1

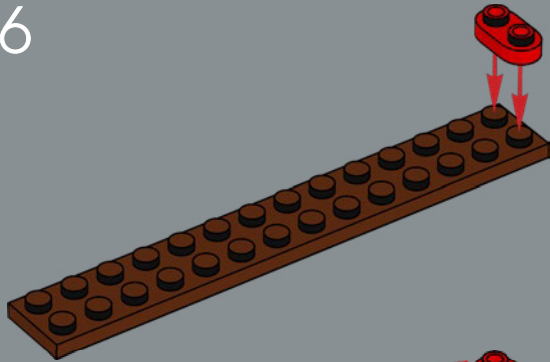

2

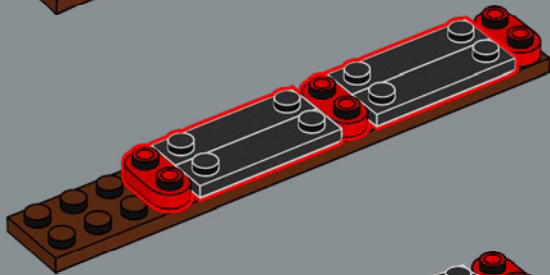

3

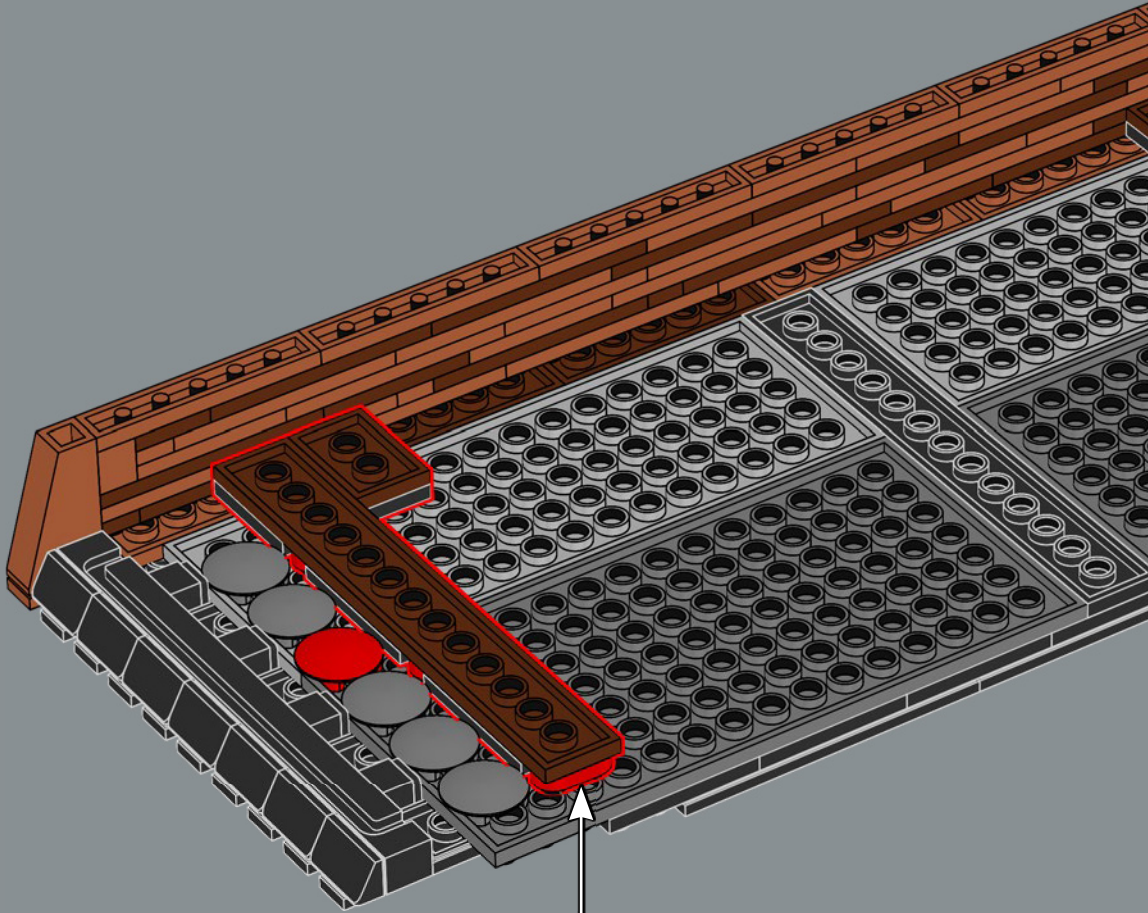
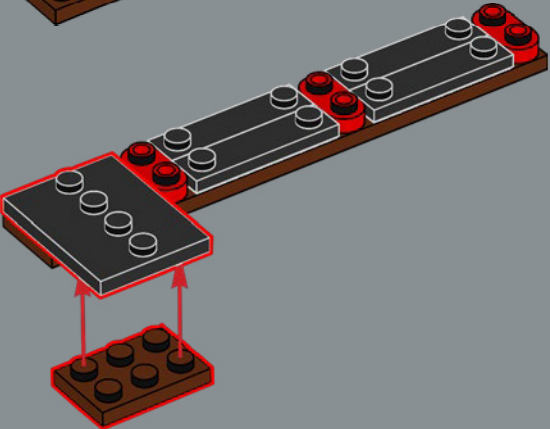

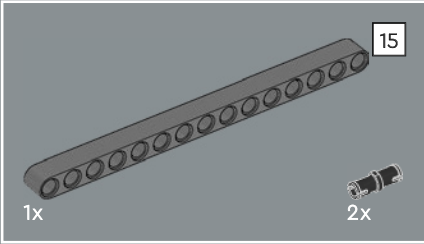
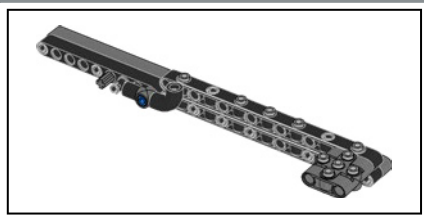

197

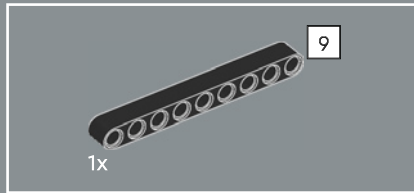
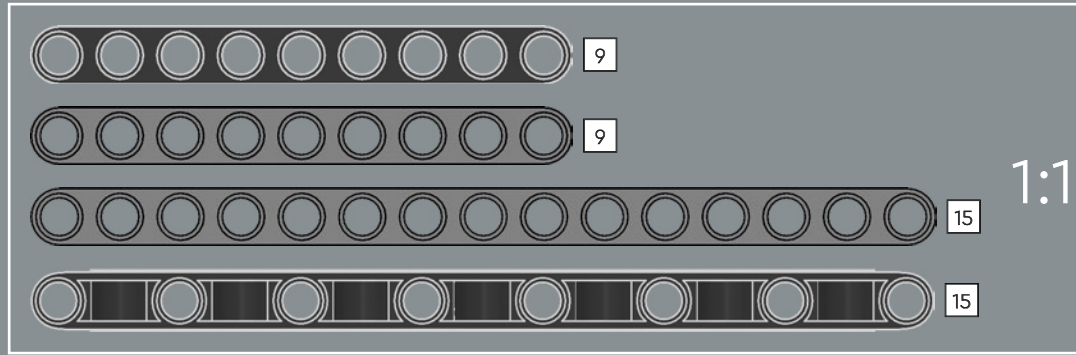

198



199

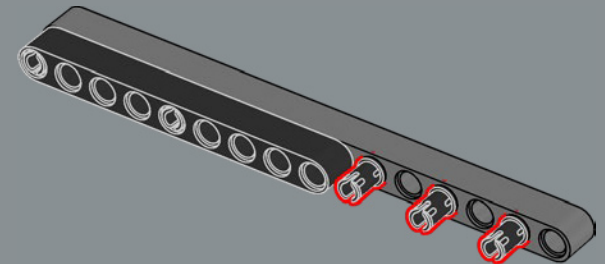
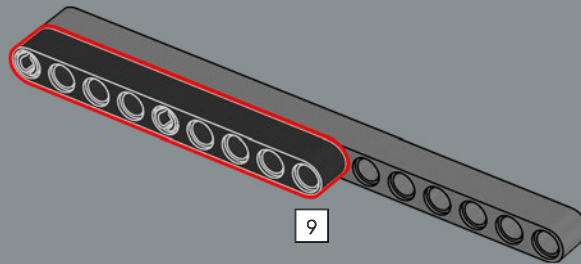
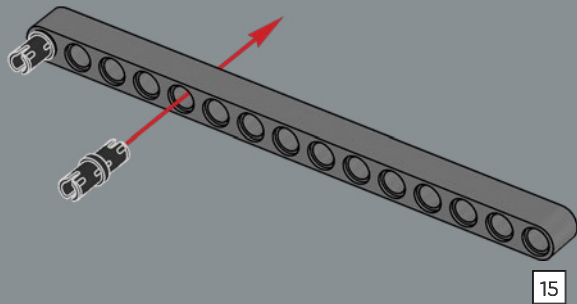

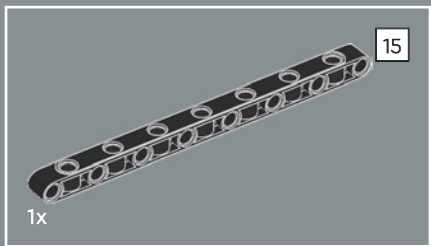

200

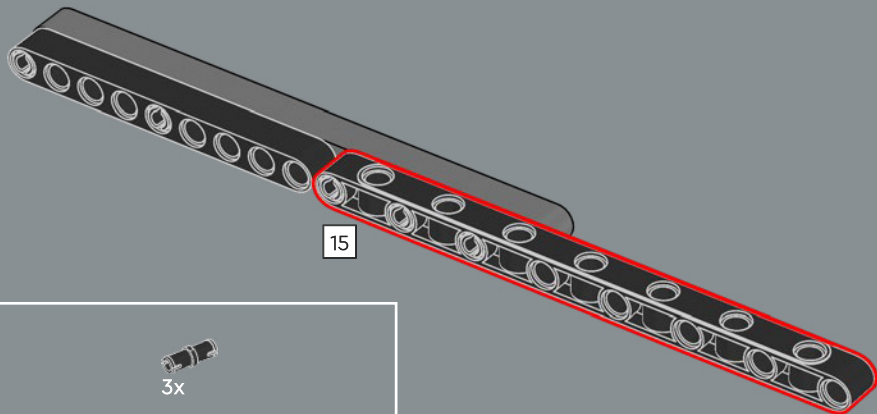

201

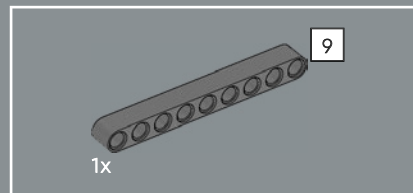
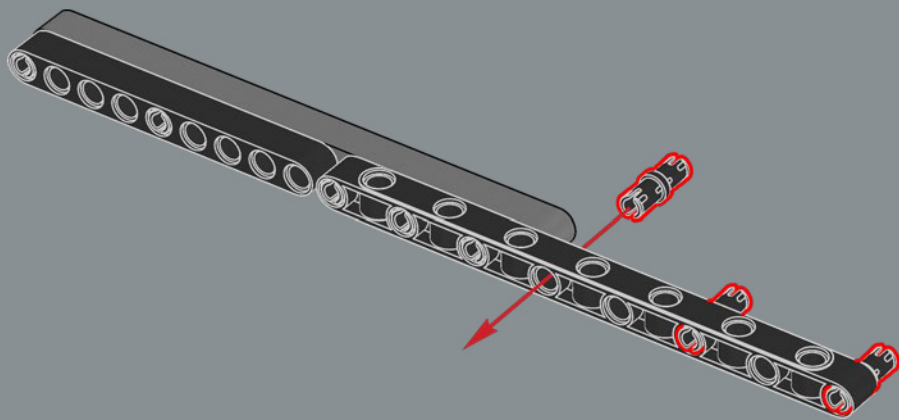

202

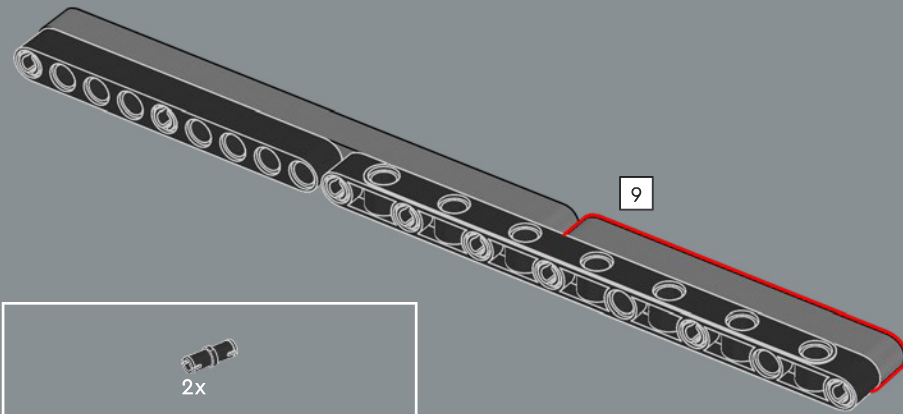

203

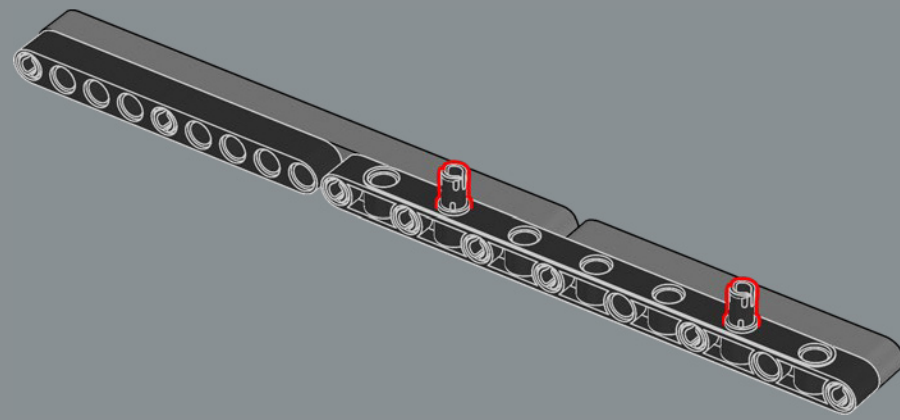

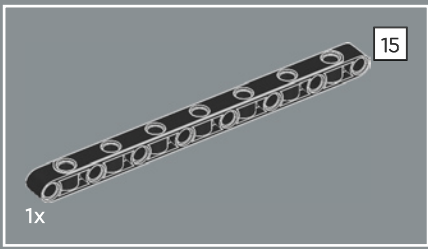

204

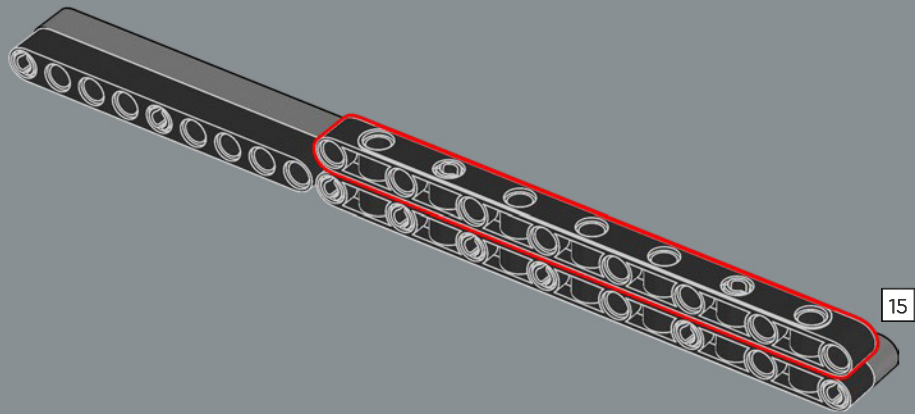

205

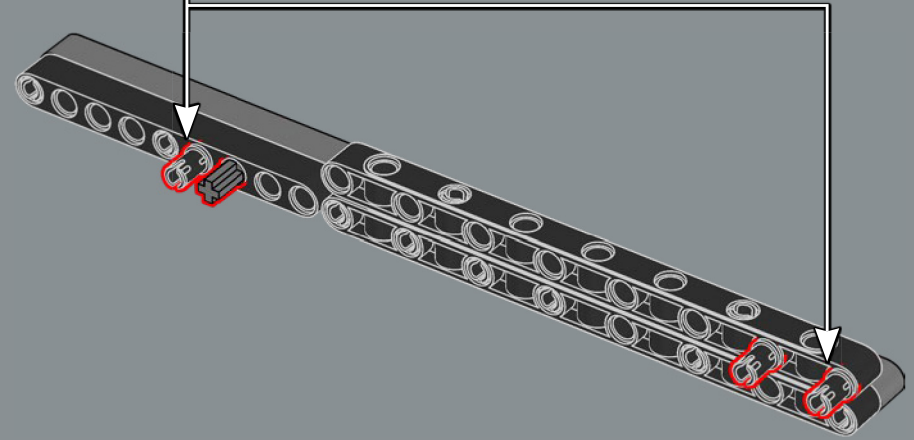
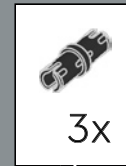

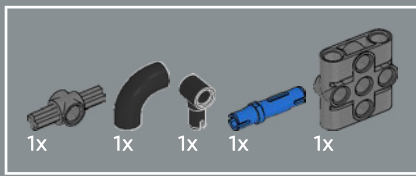

206

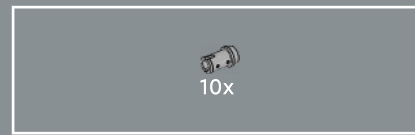
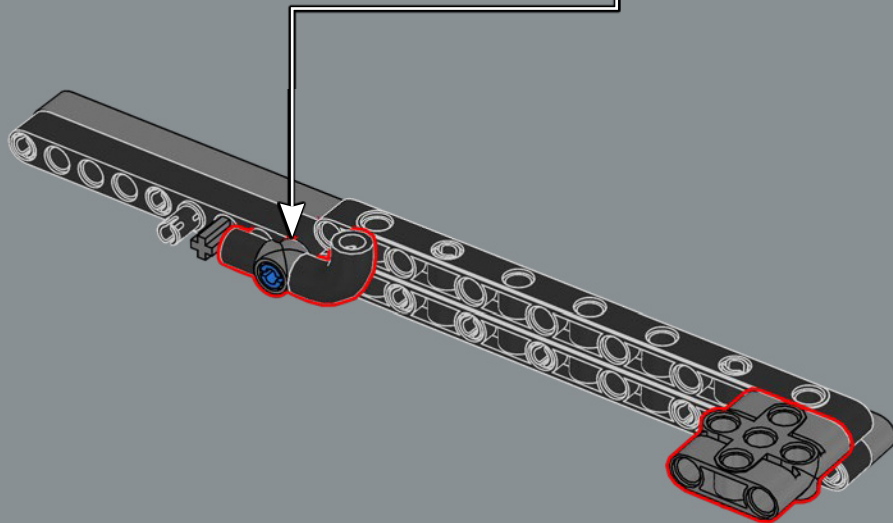
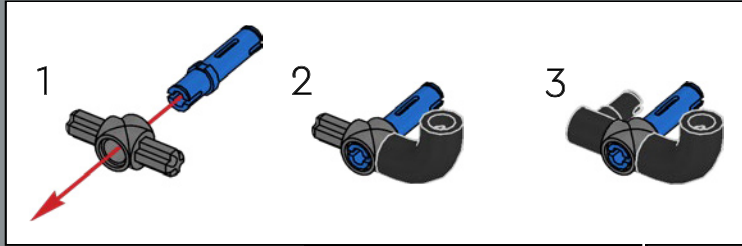

207

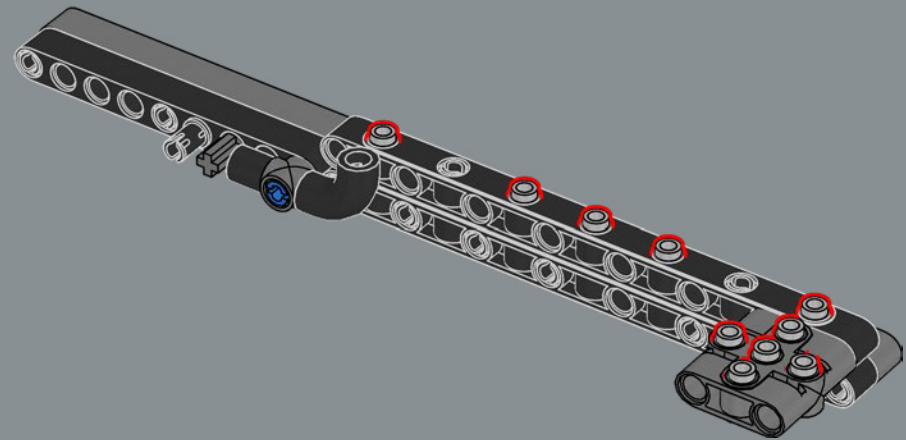

208

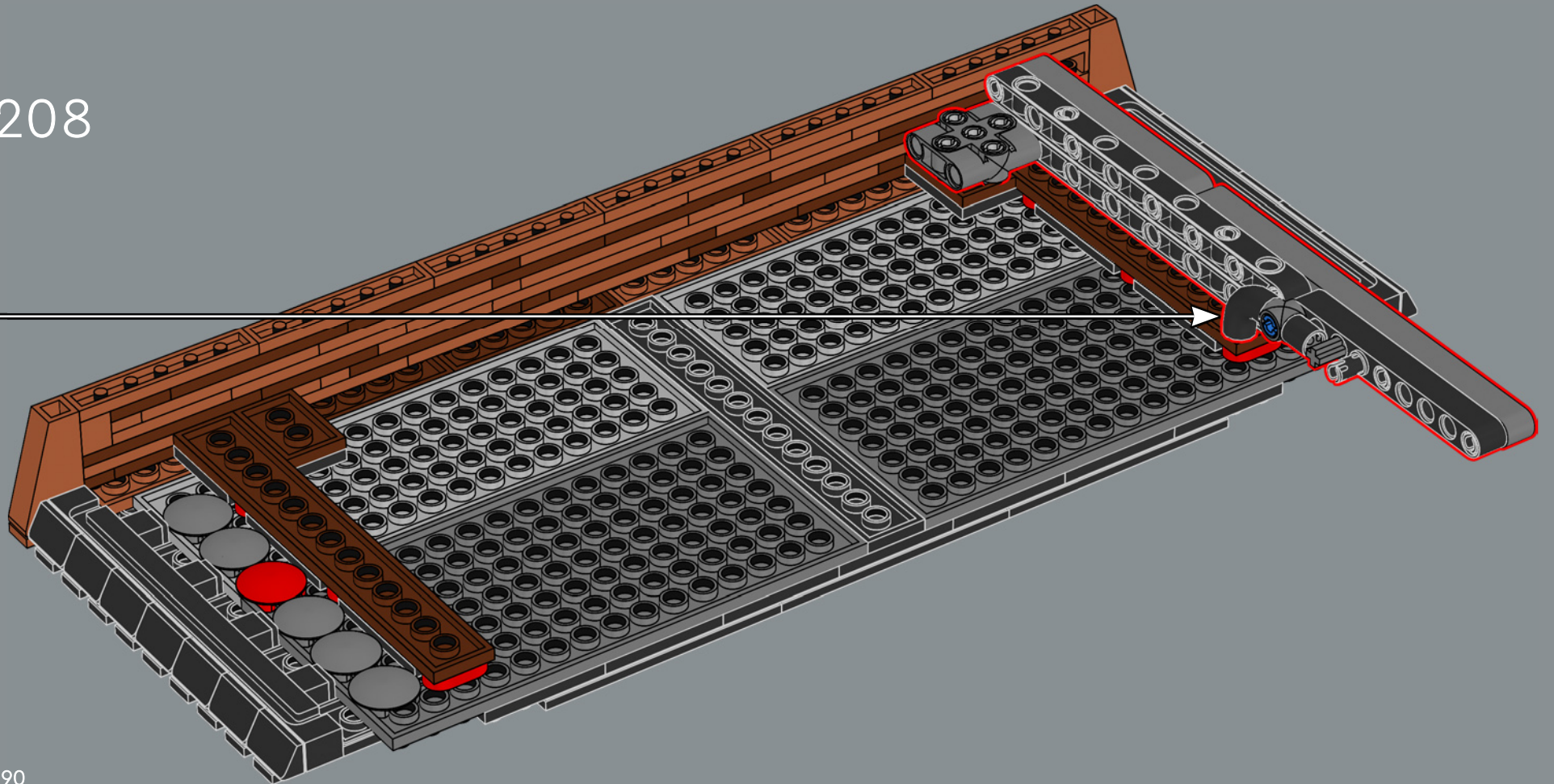

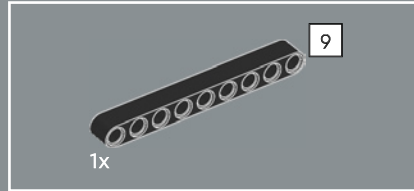
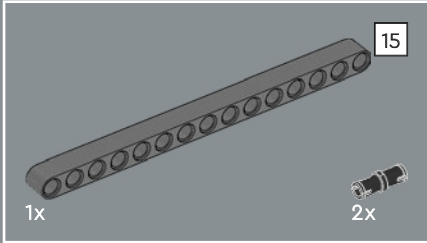
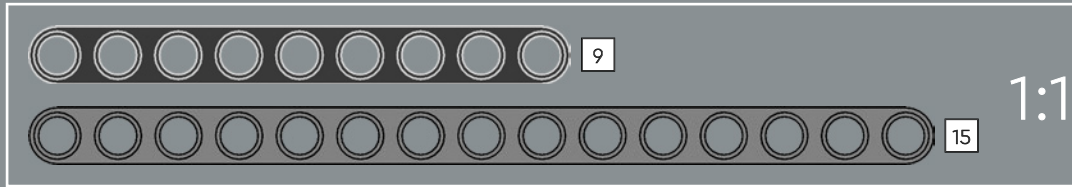
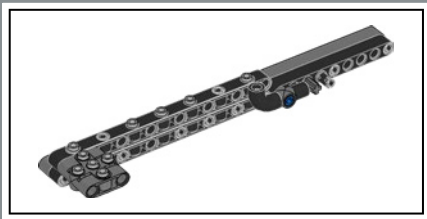

209

210

211

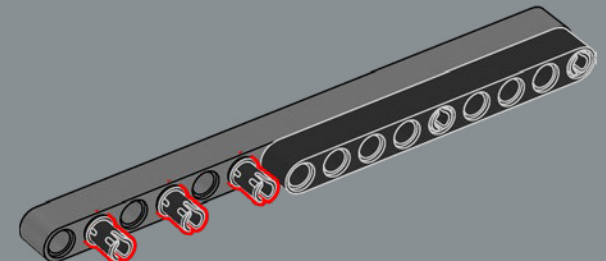
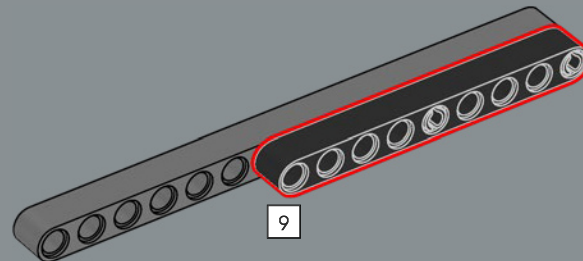
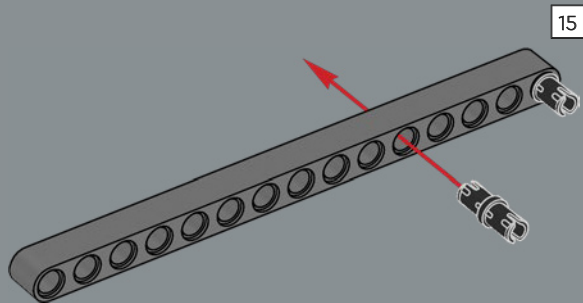

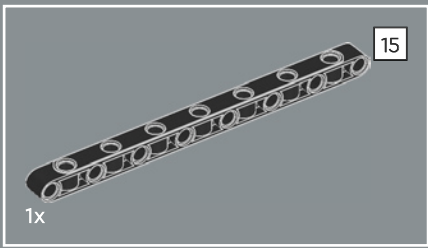

212

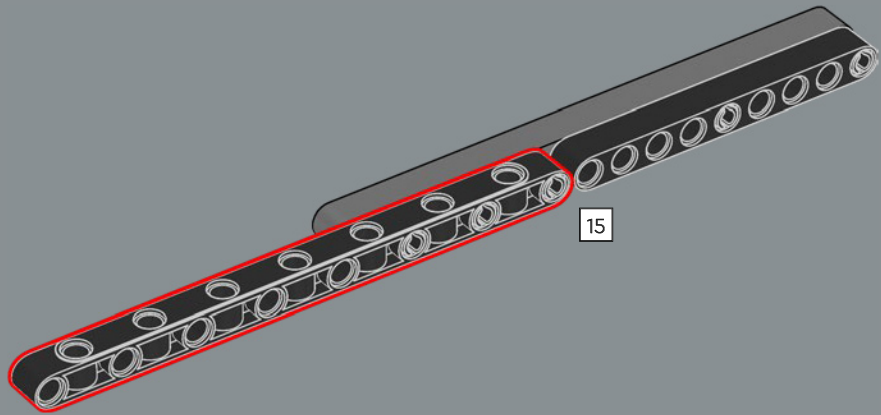

213

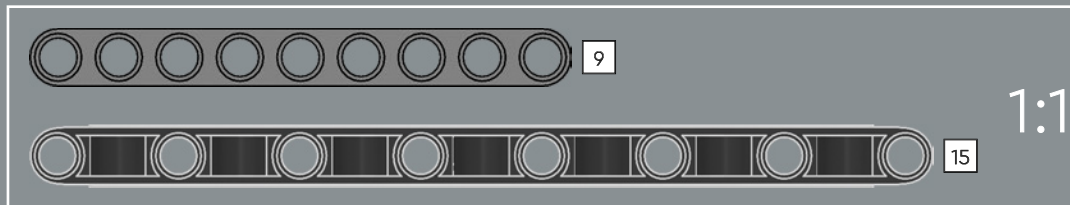
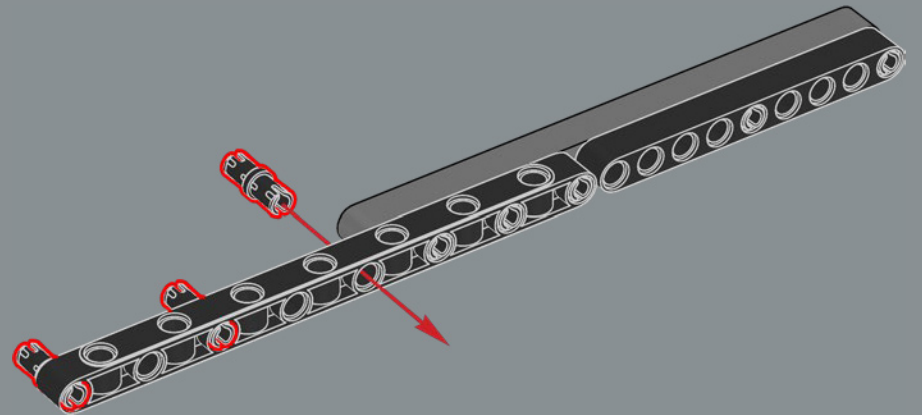

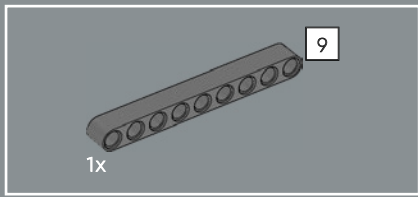

214

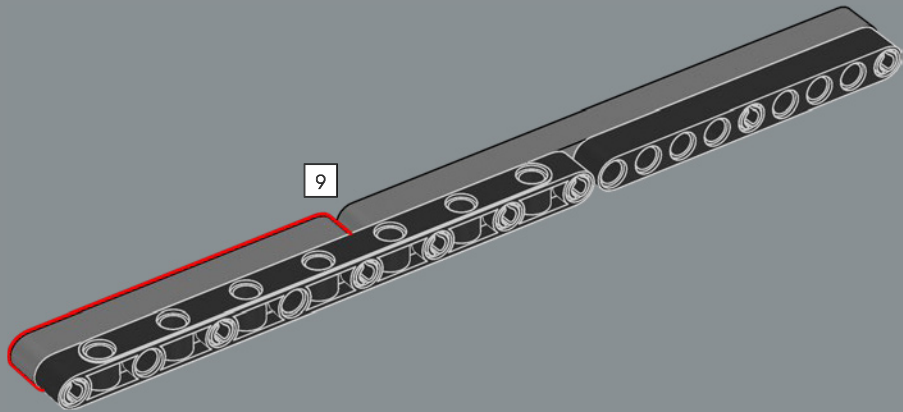

215

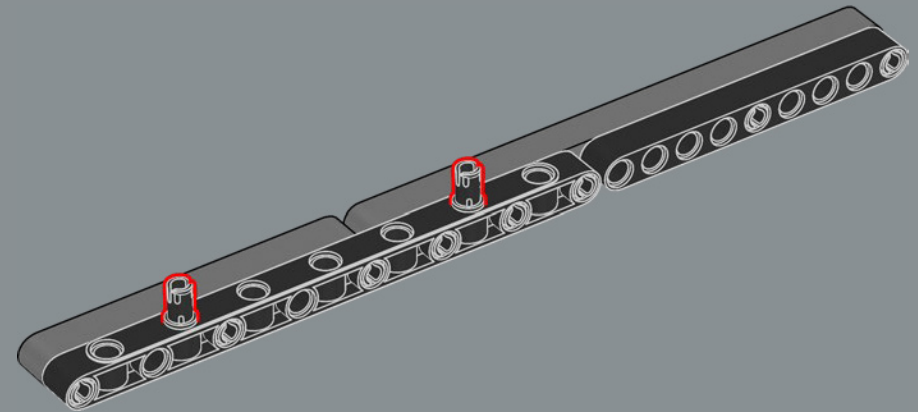

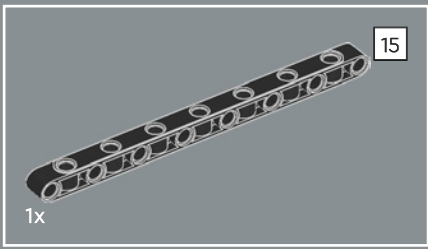

216

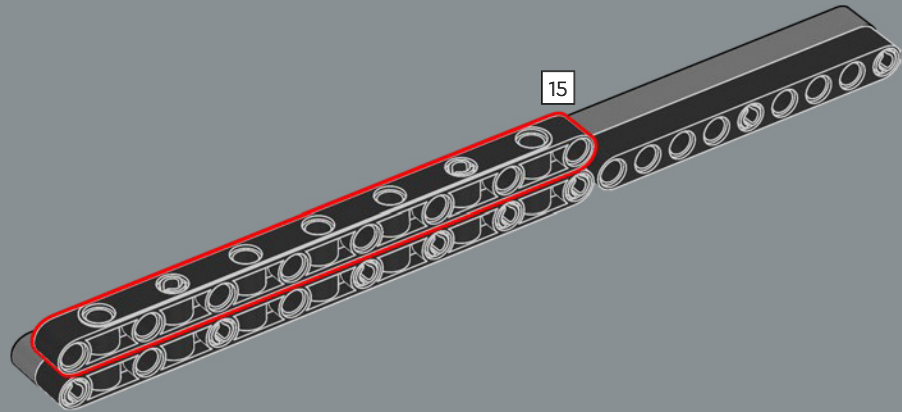

217

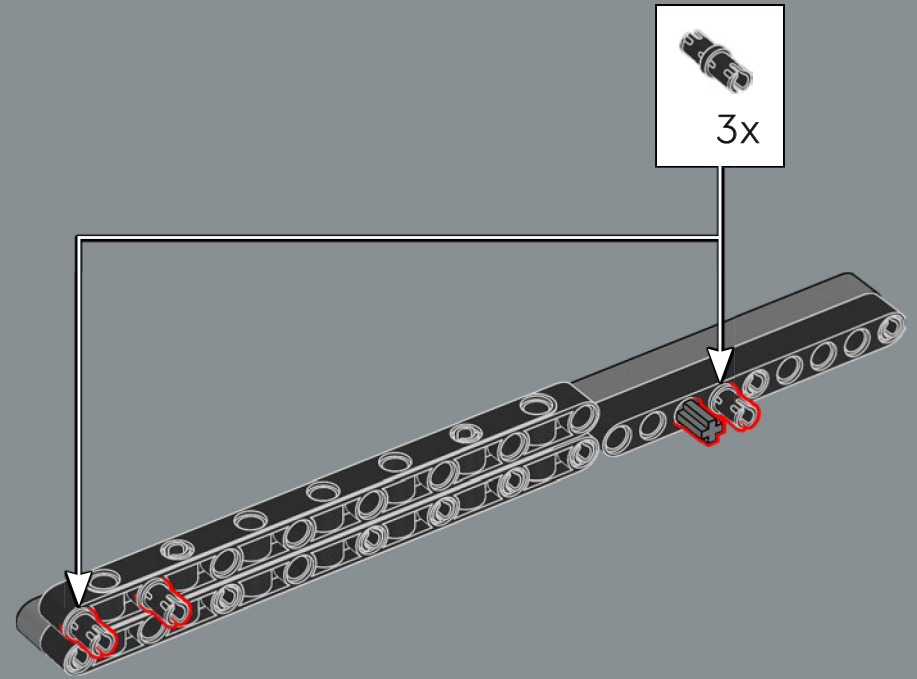

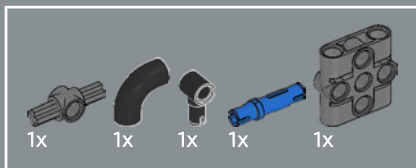

218

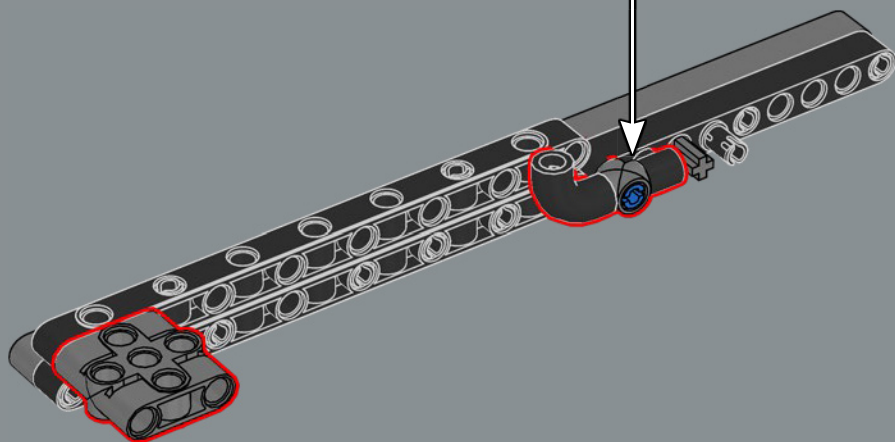
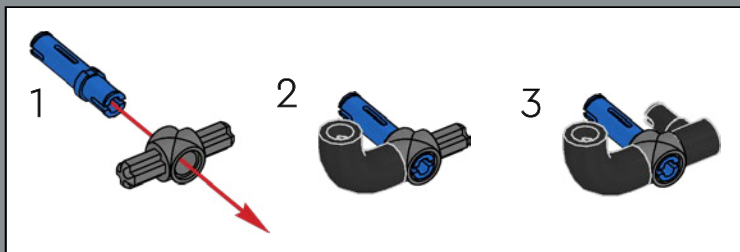

219

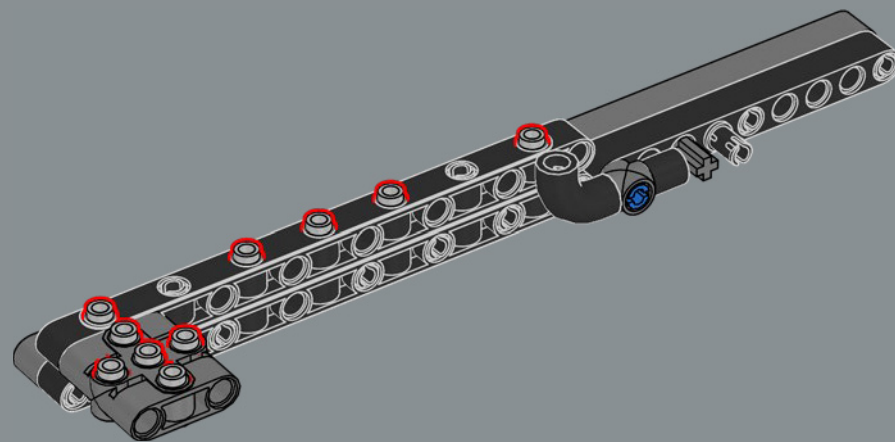

220

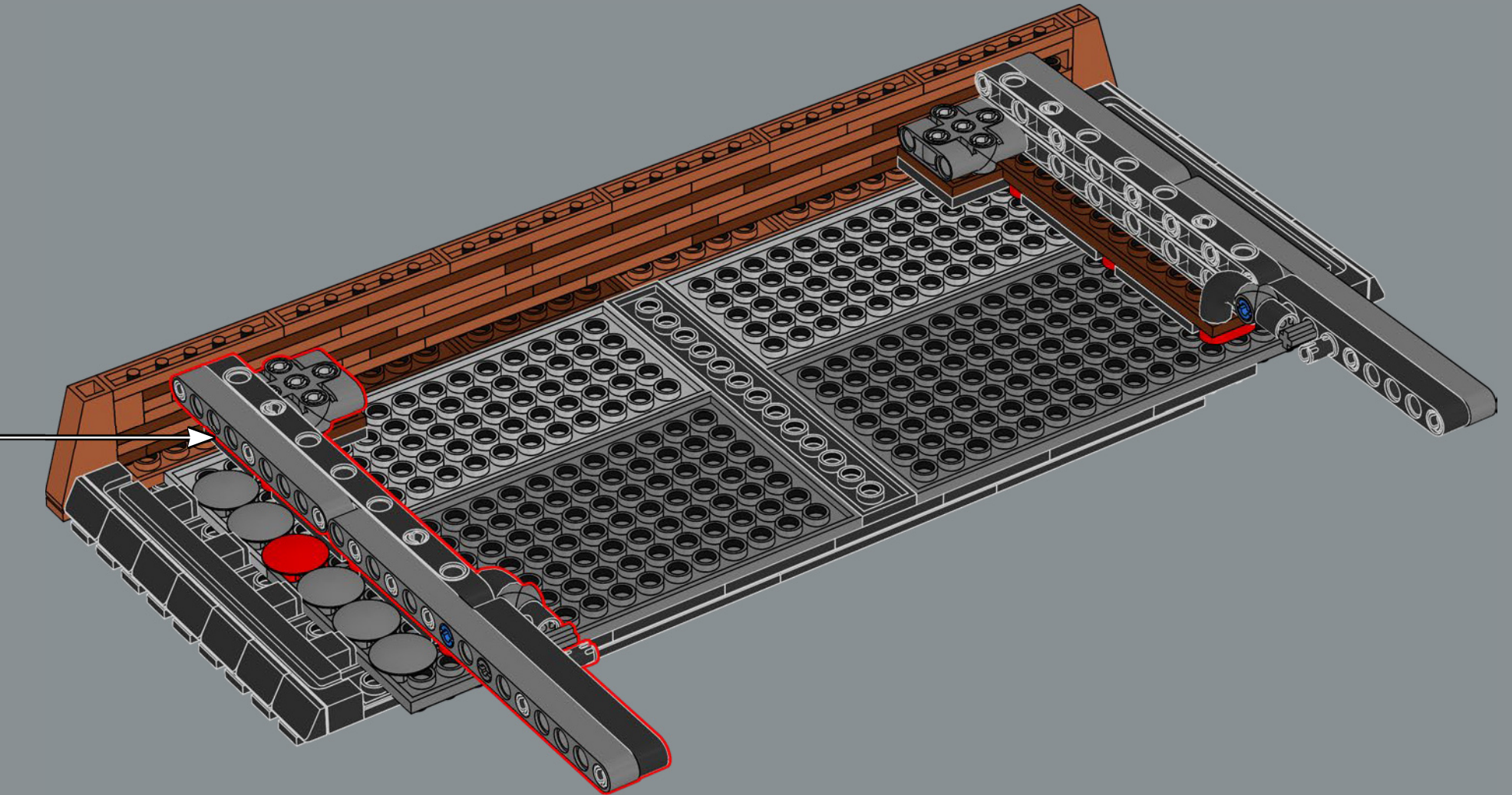

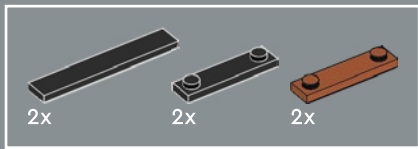

221

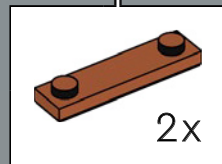
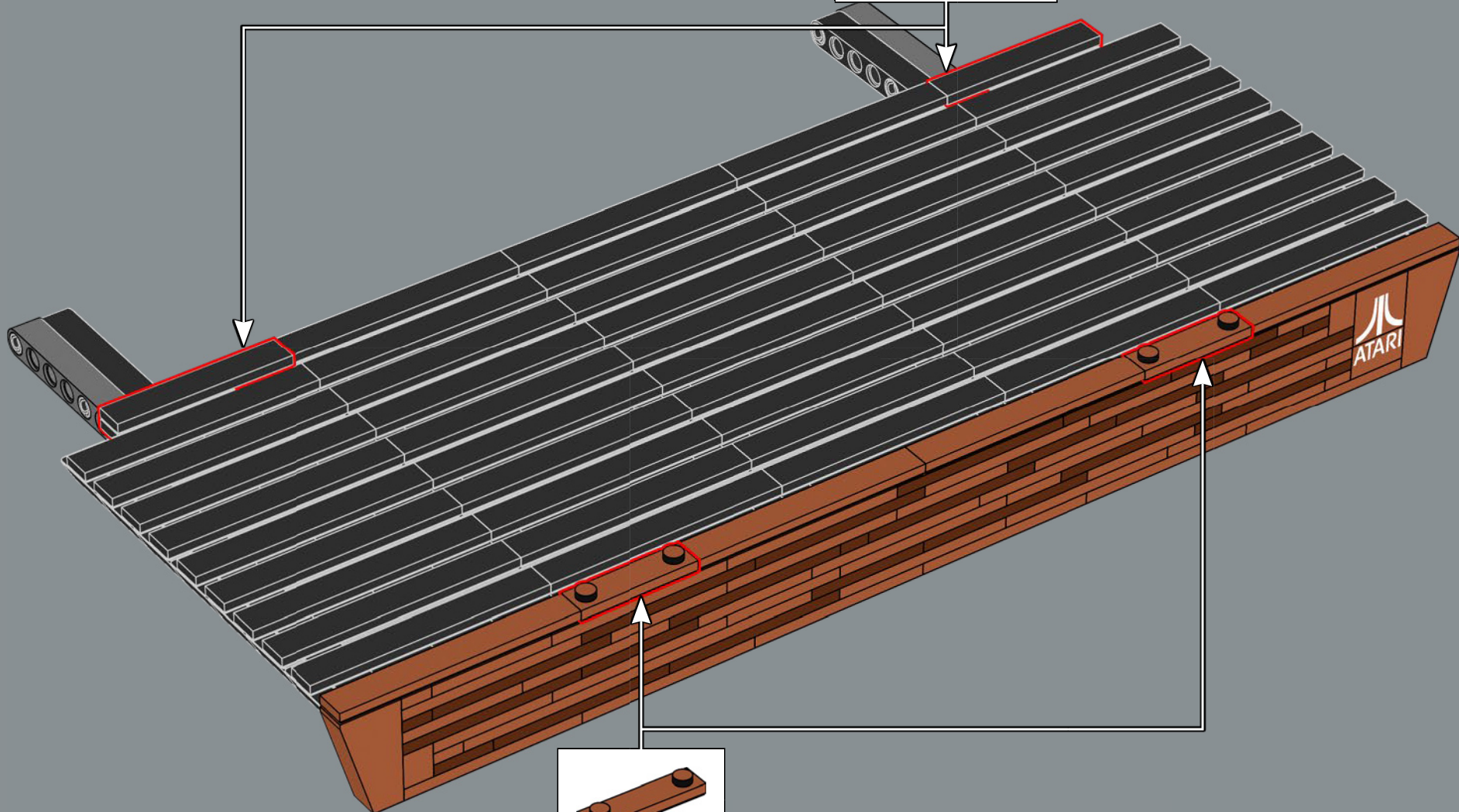
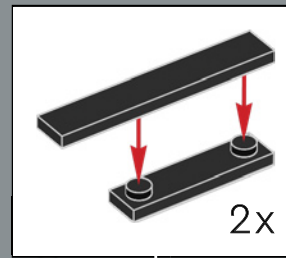

222

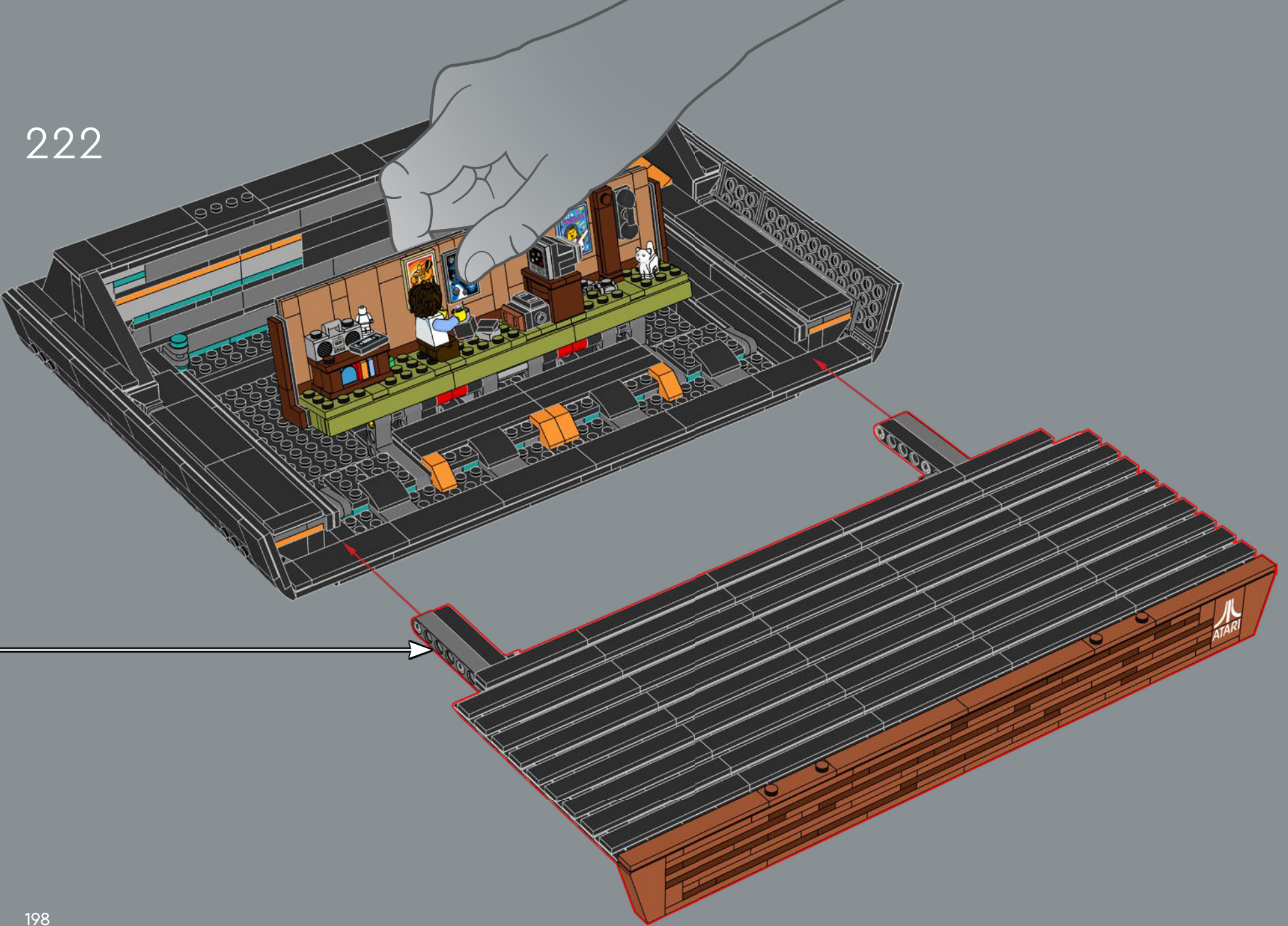

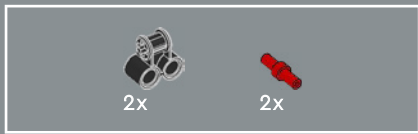

223

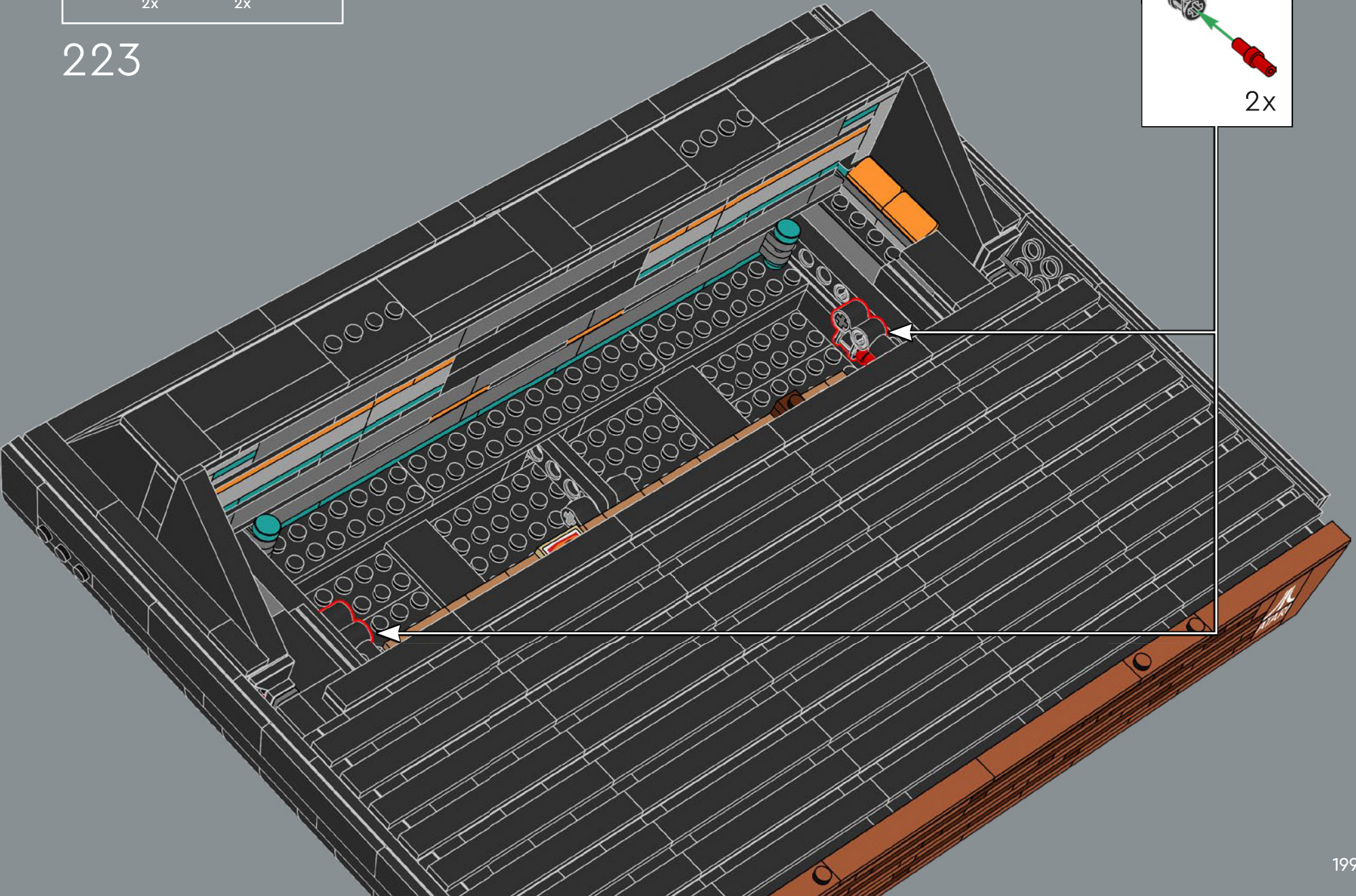
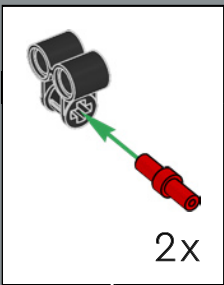





224

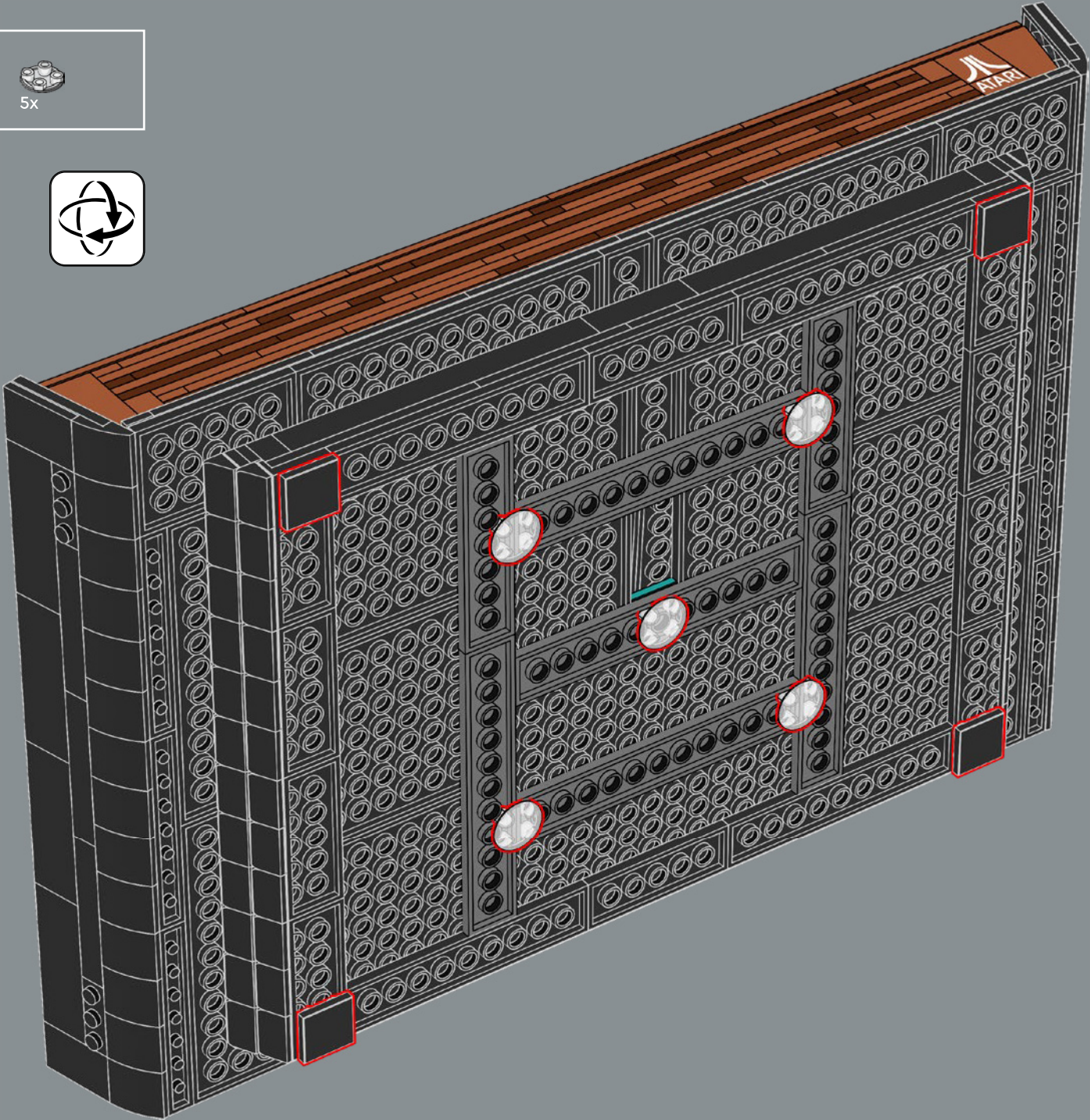

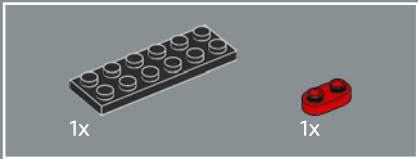
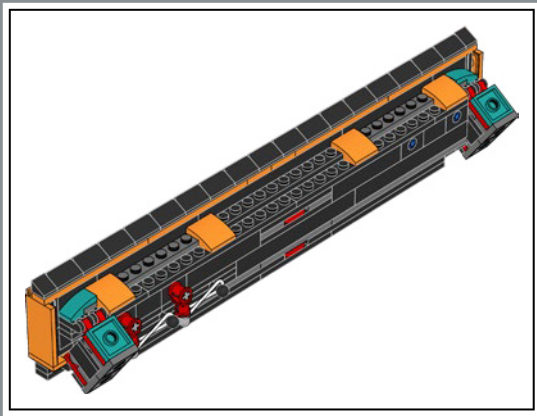

225

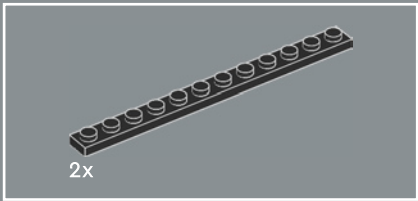
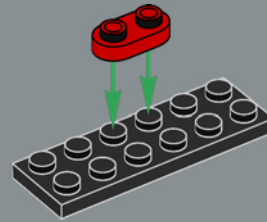

226

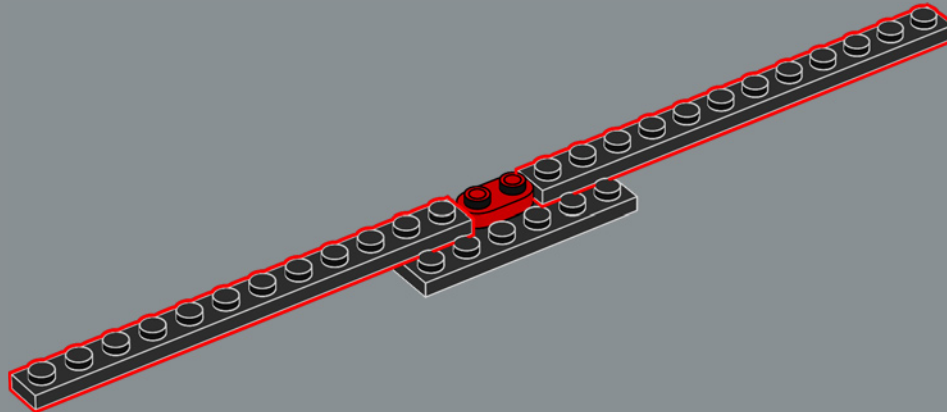

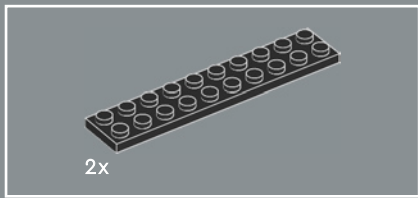

227

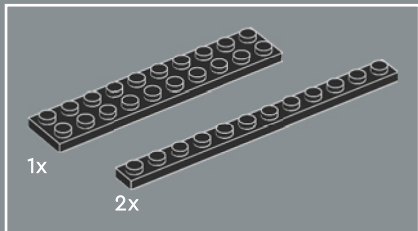
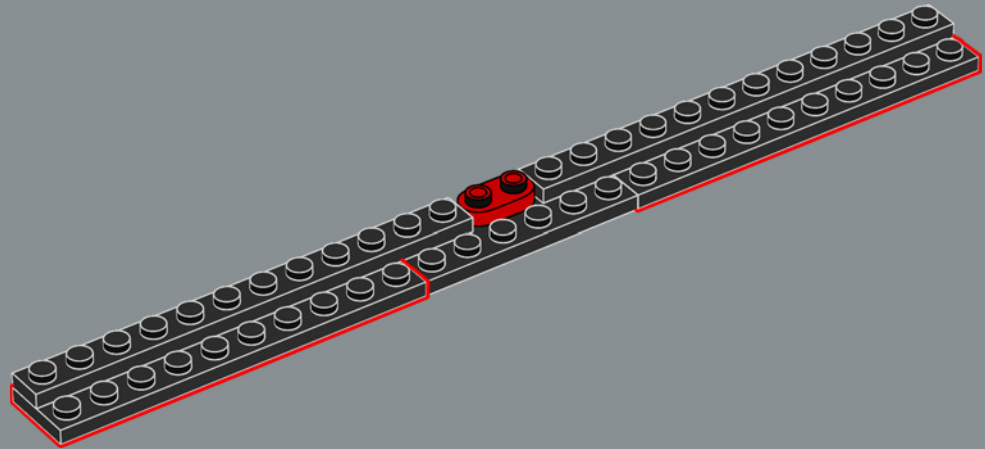

228

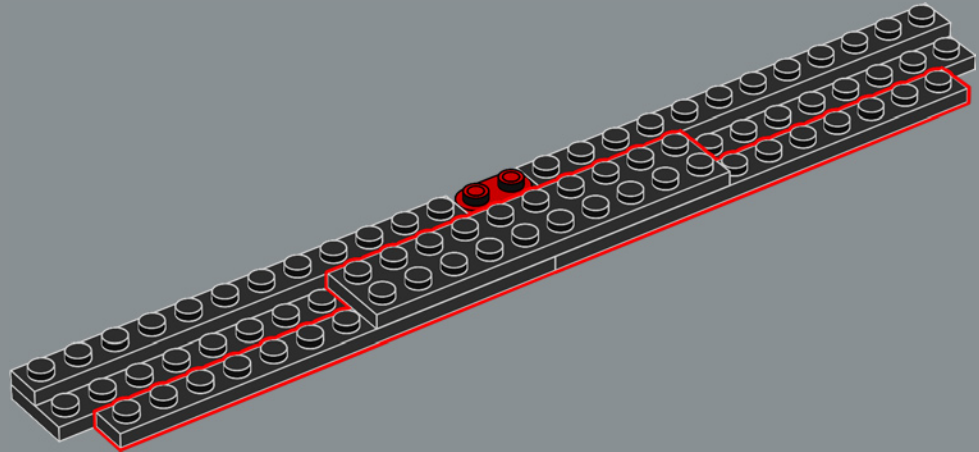

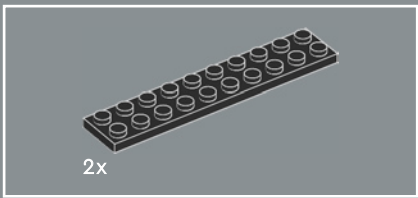

229

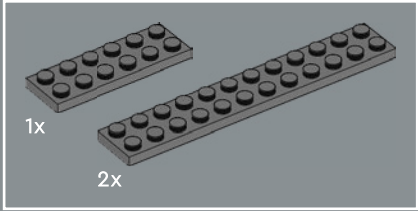
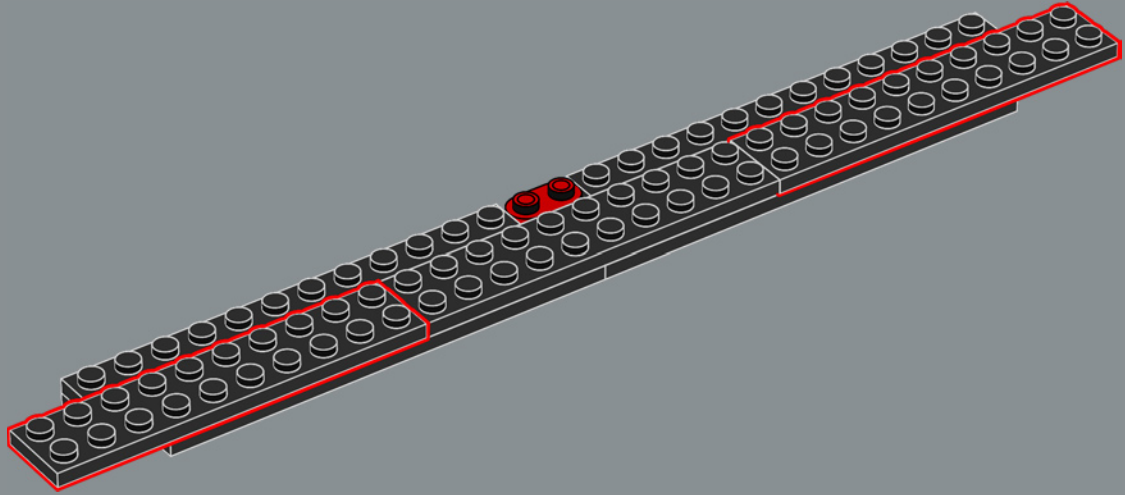

230

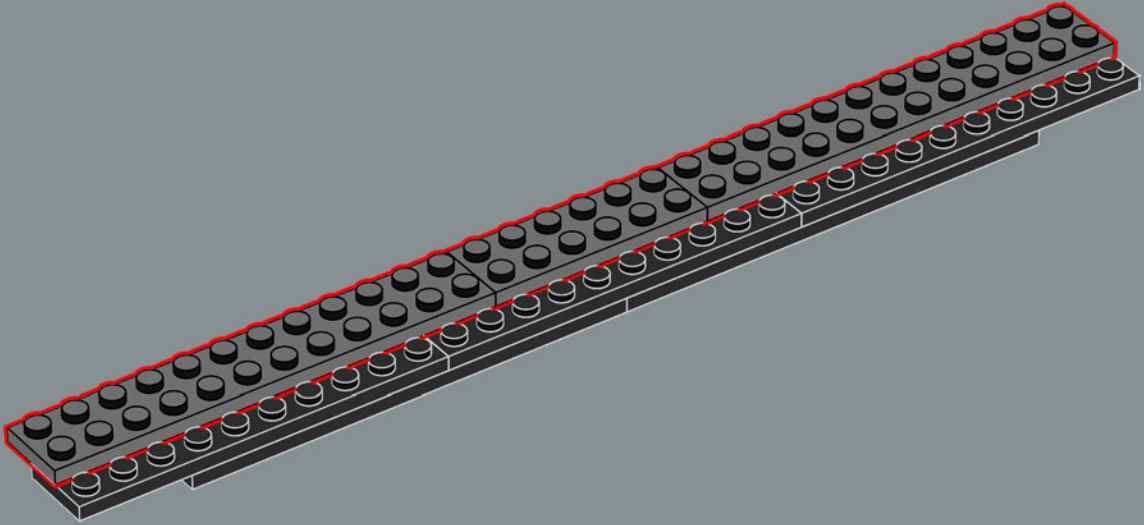

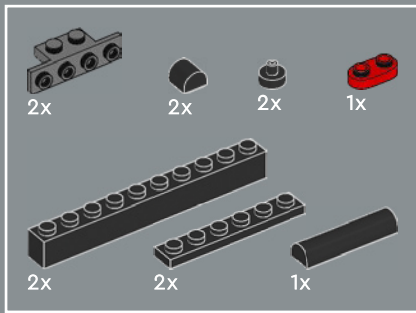

231

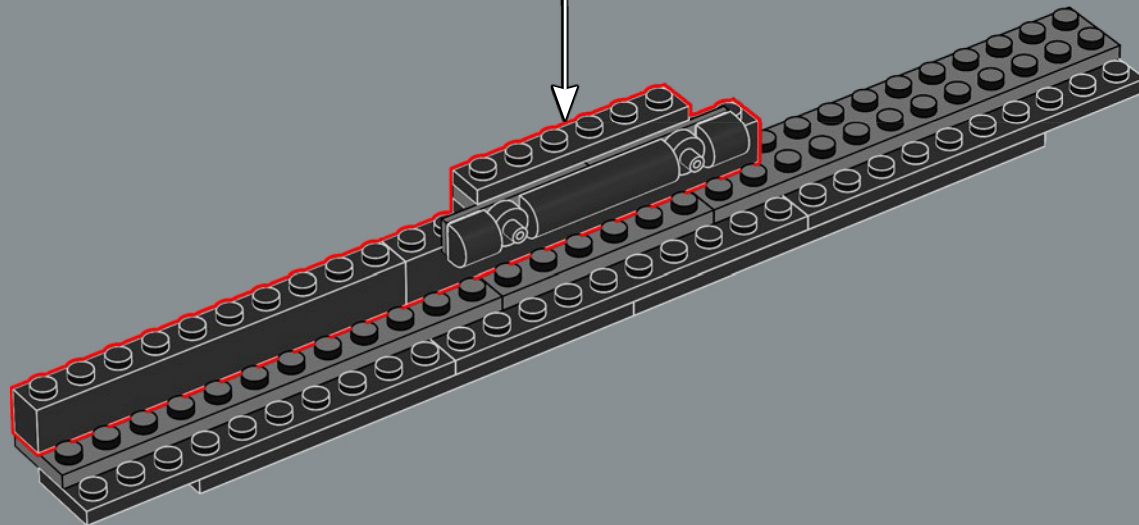
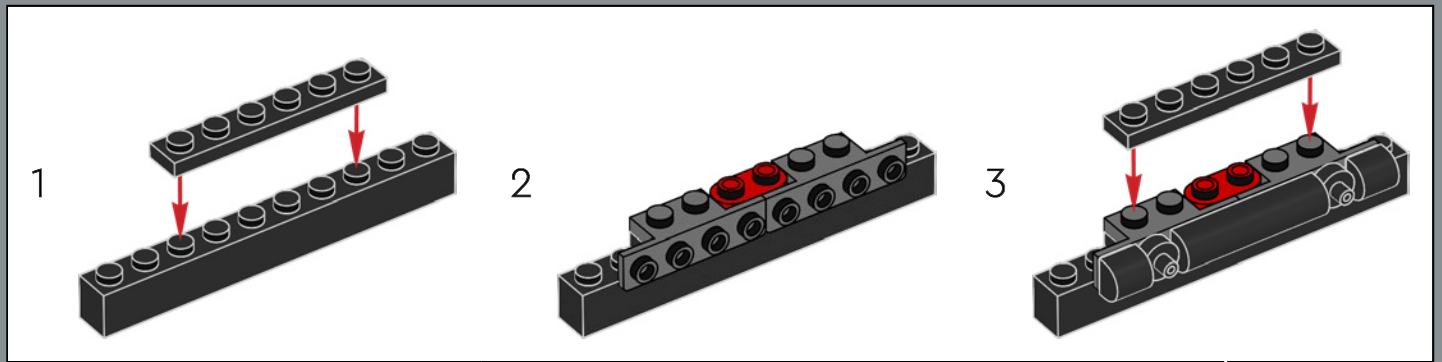

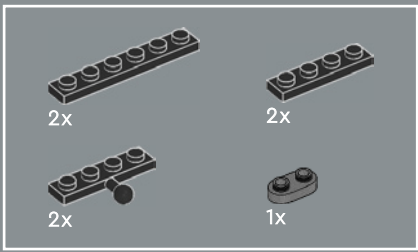

232

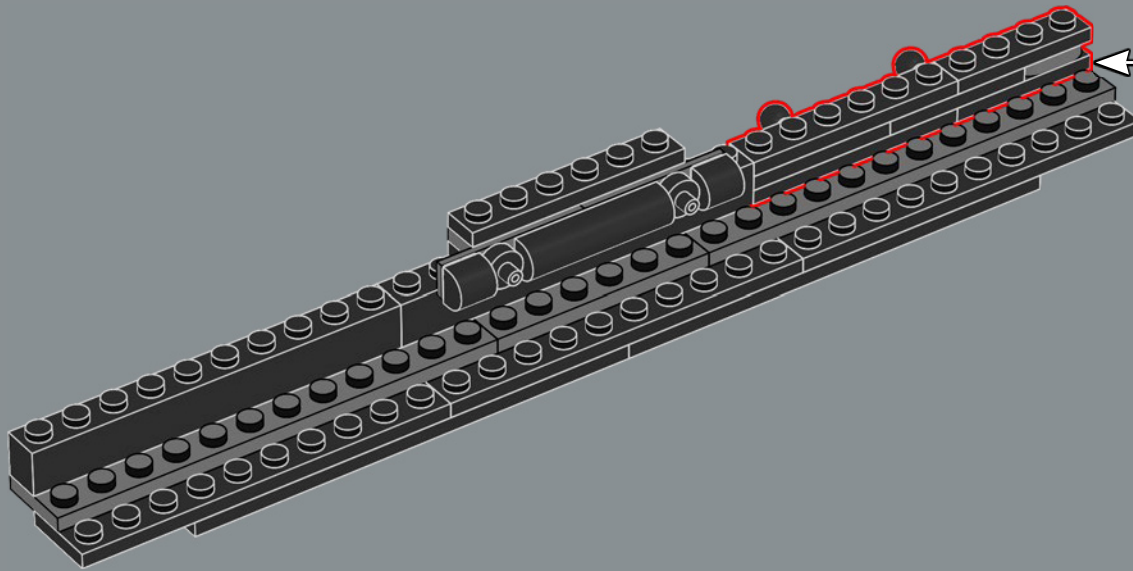
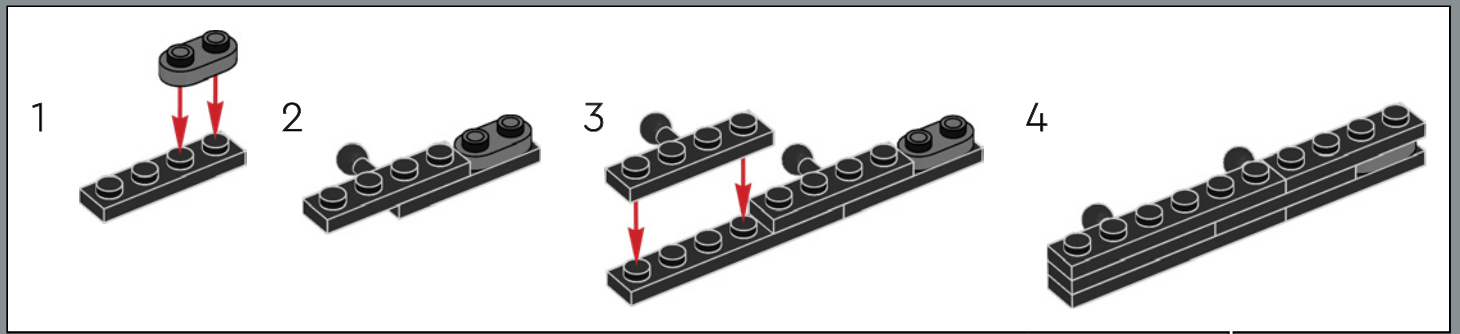

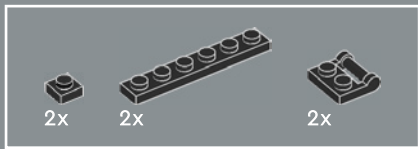

233

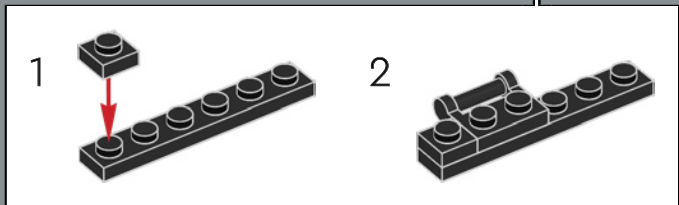
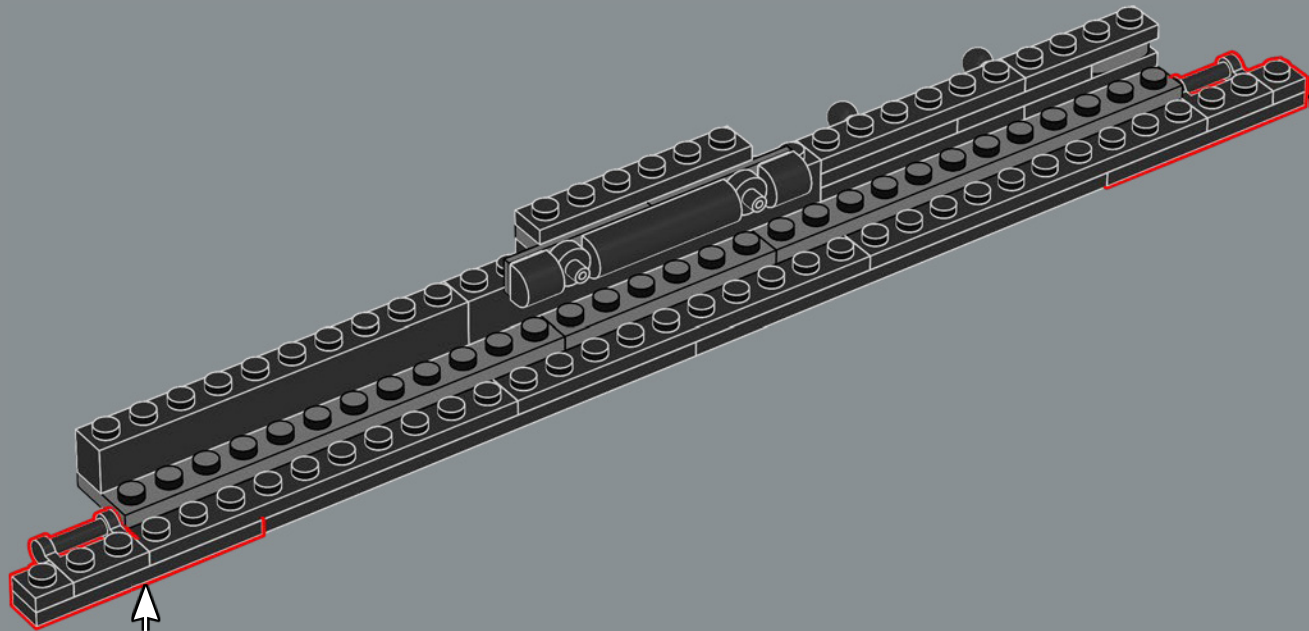
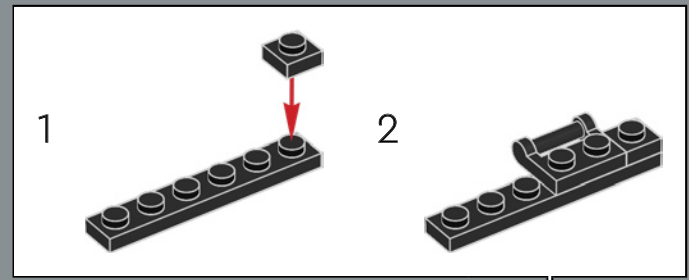

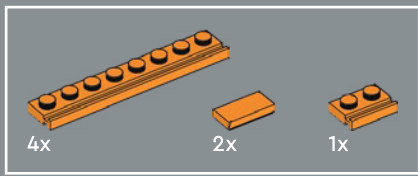

234

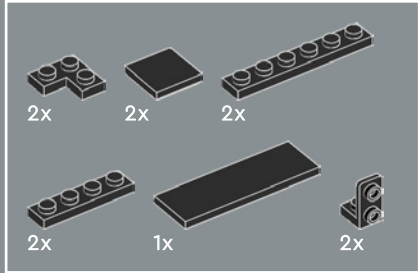
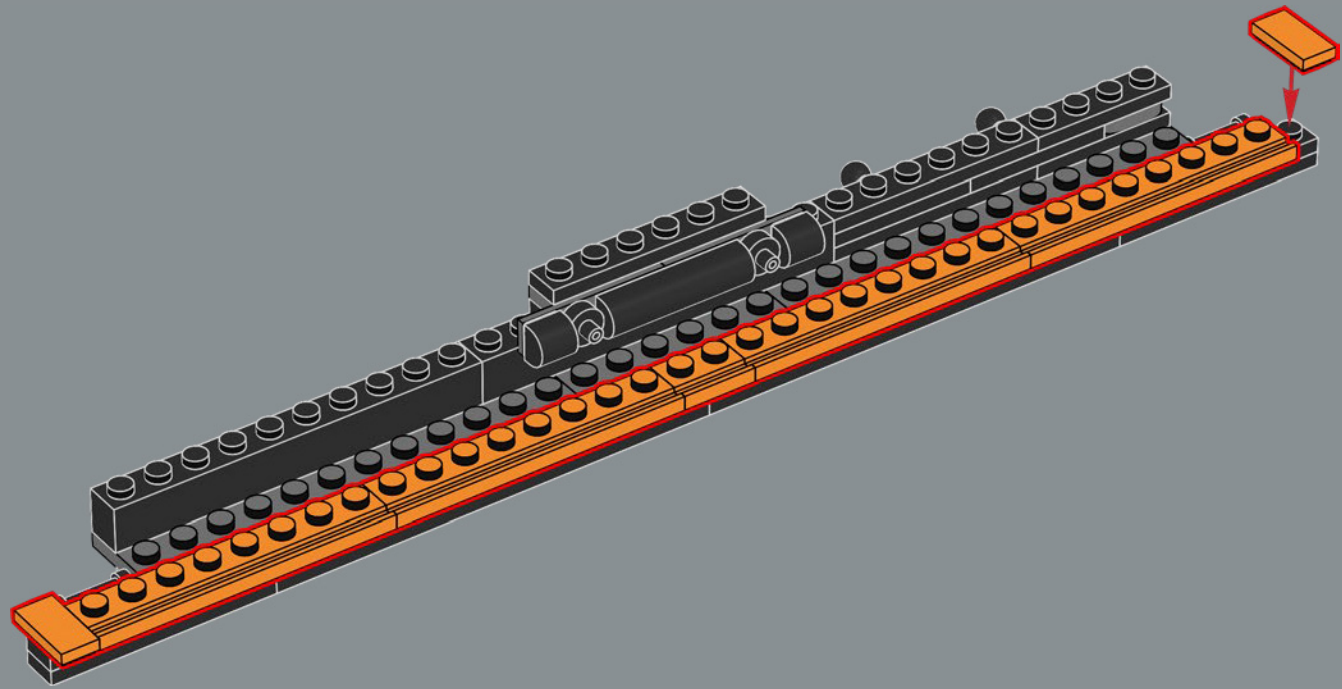

235

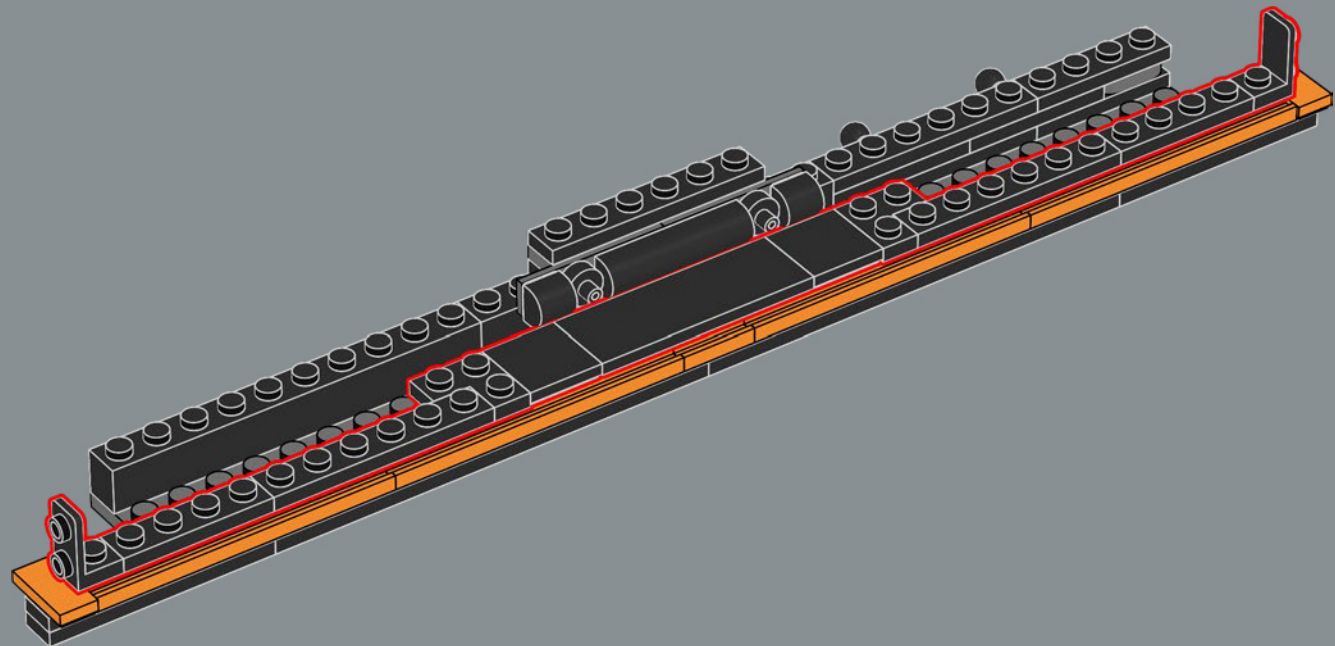

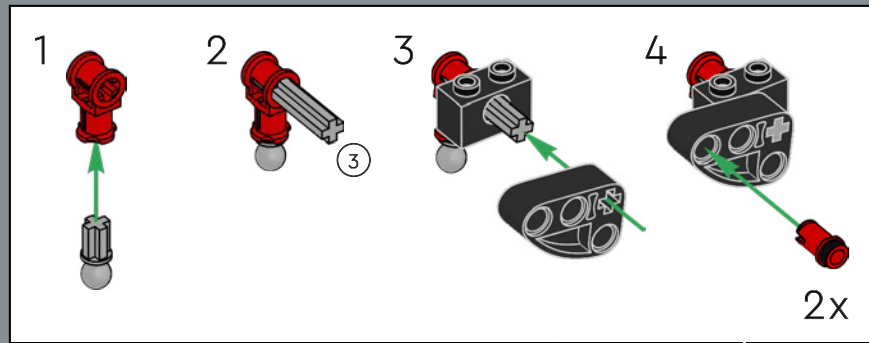
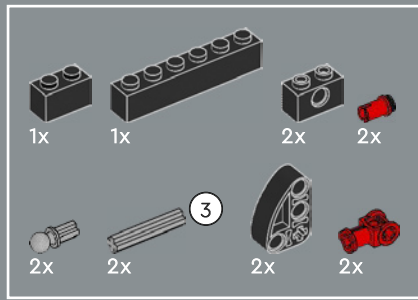

236

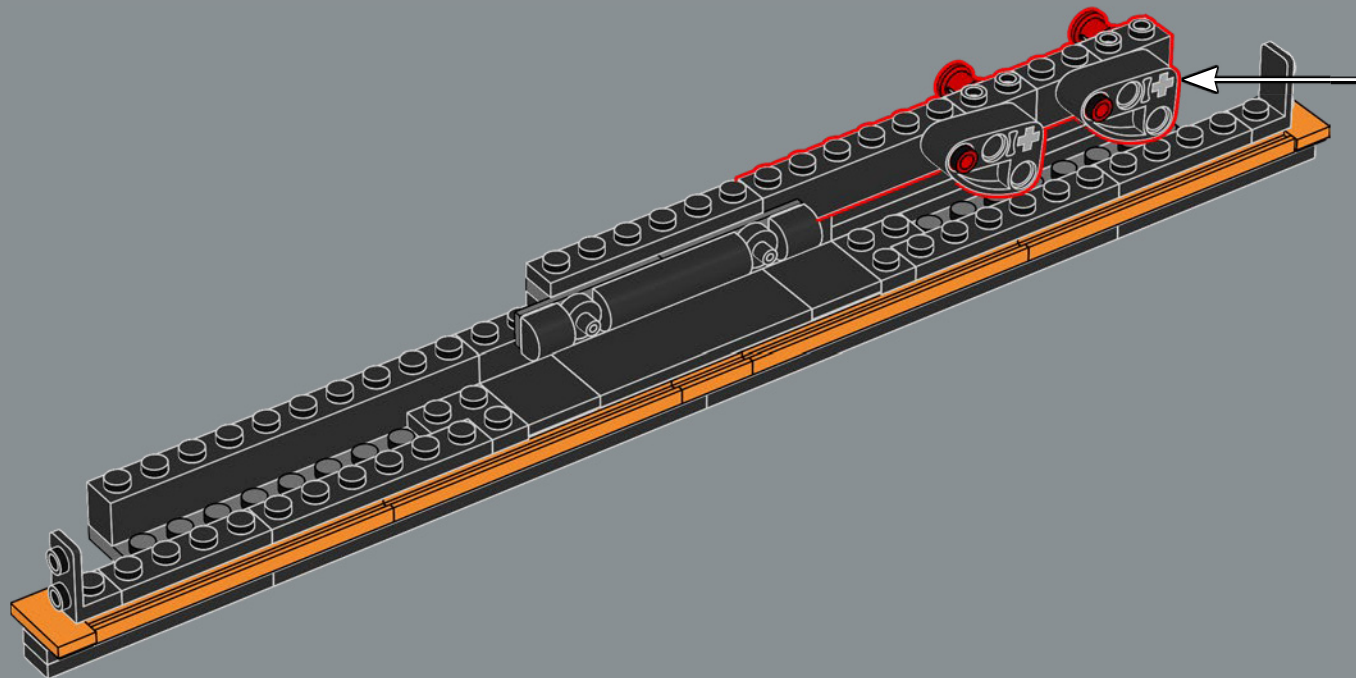

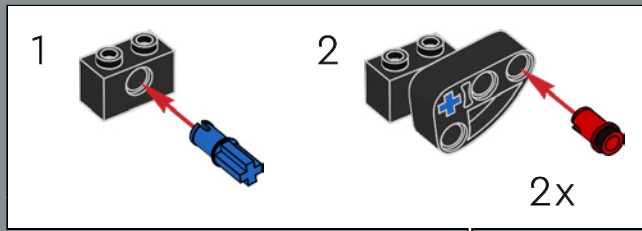
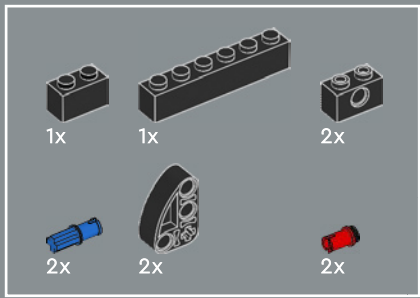

237

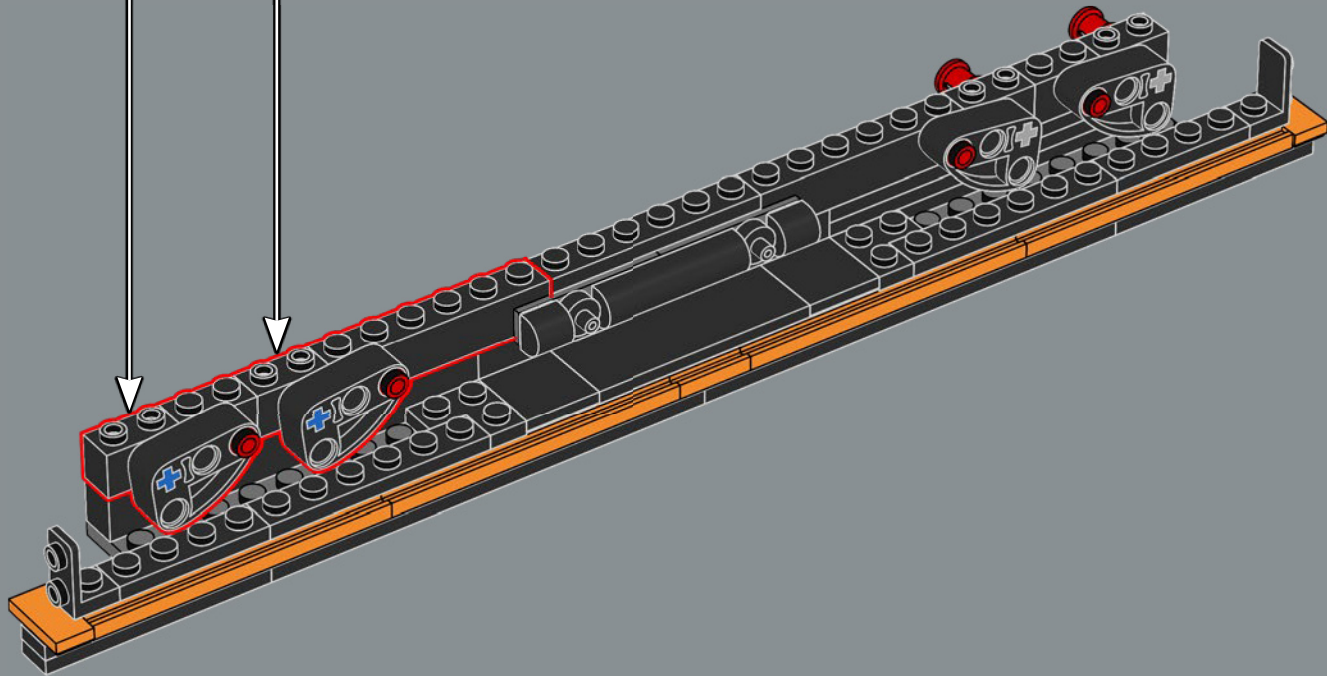

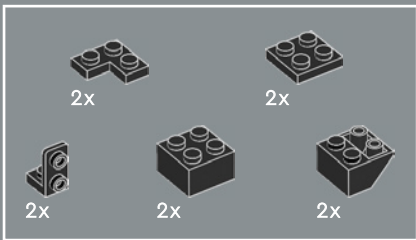

238

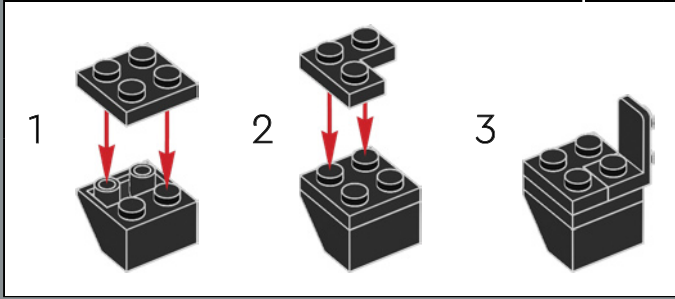
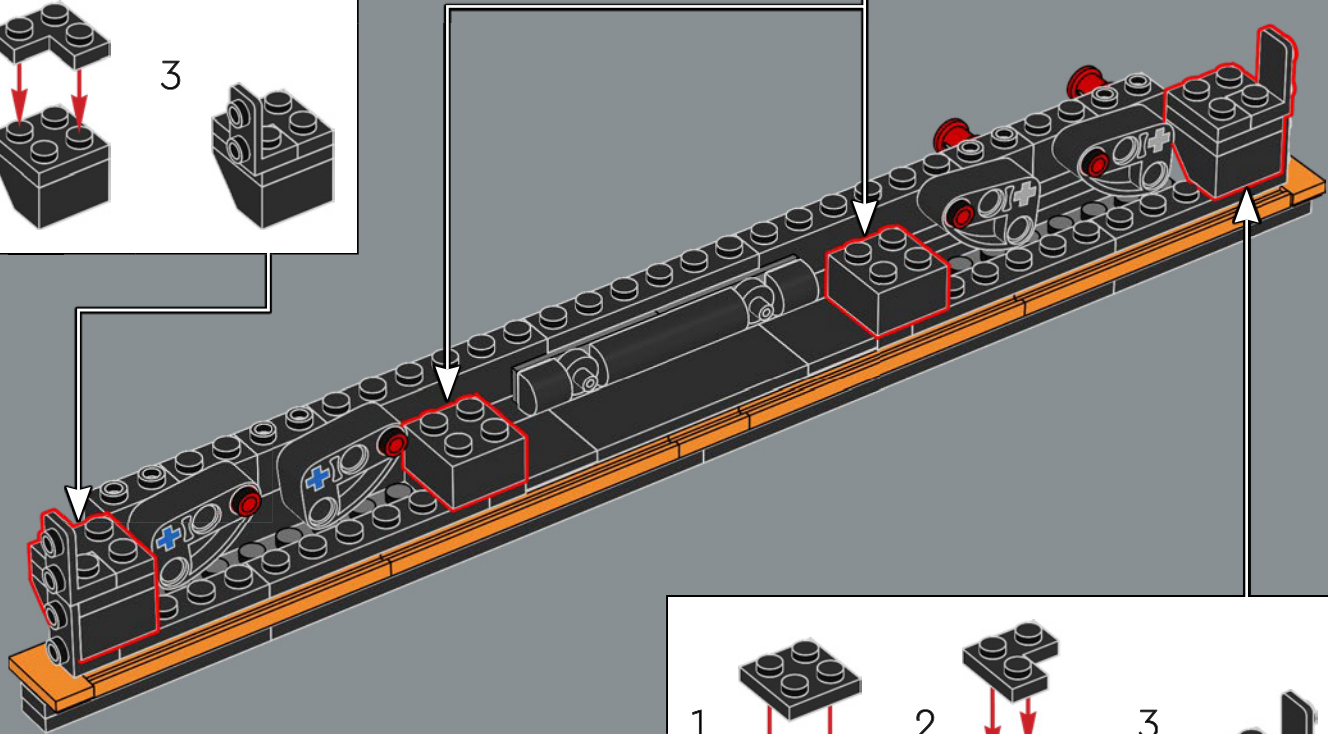
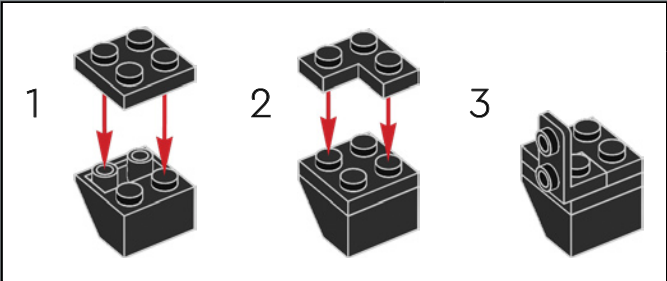
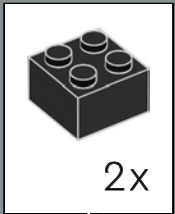

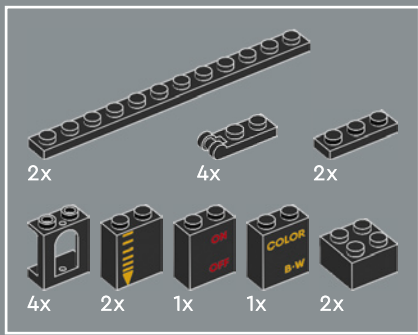

239

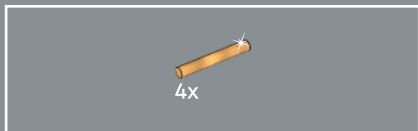
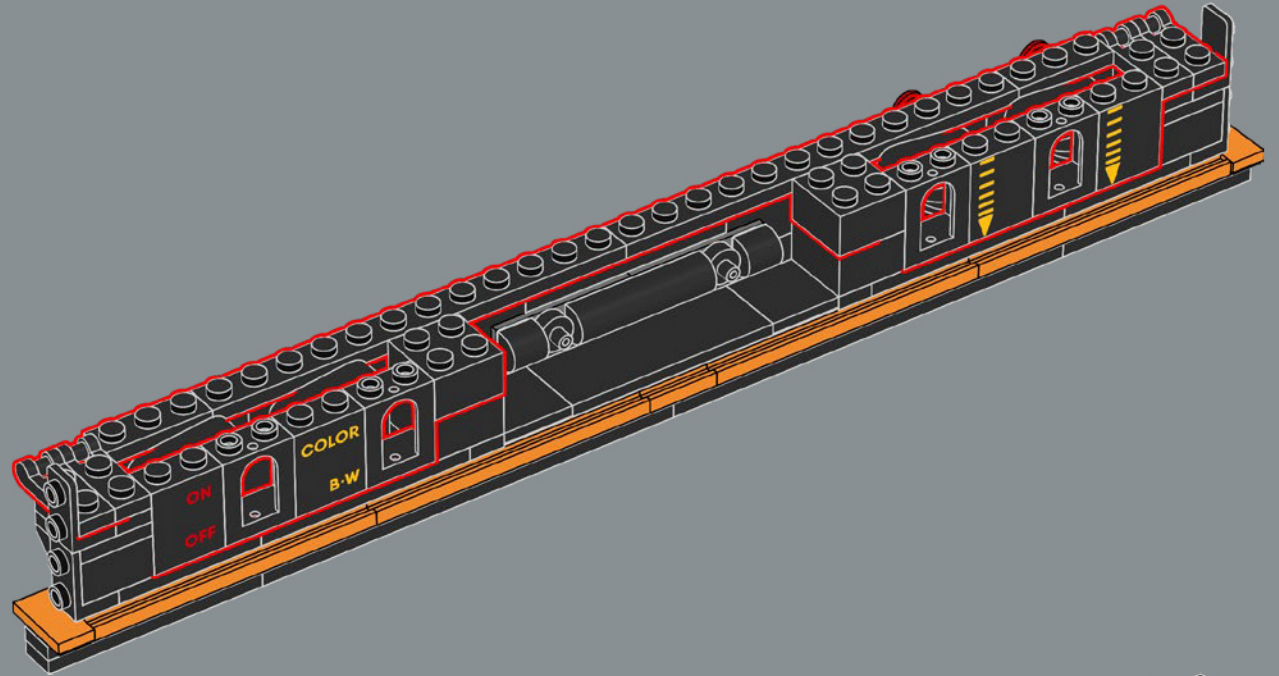

240

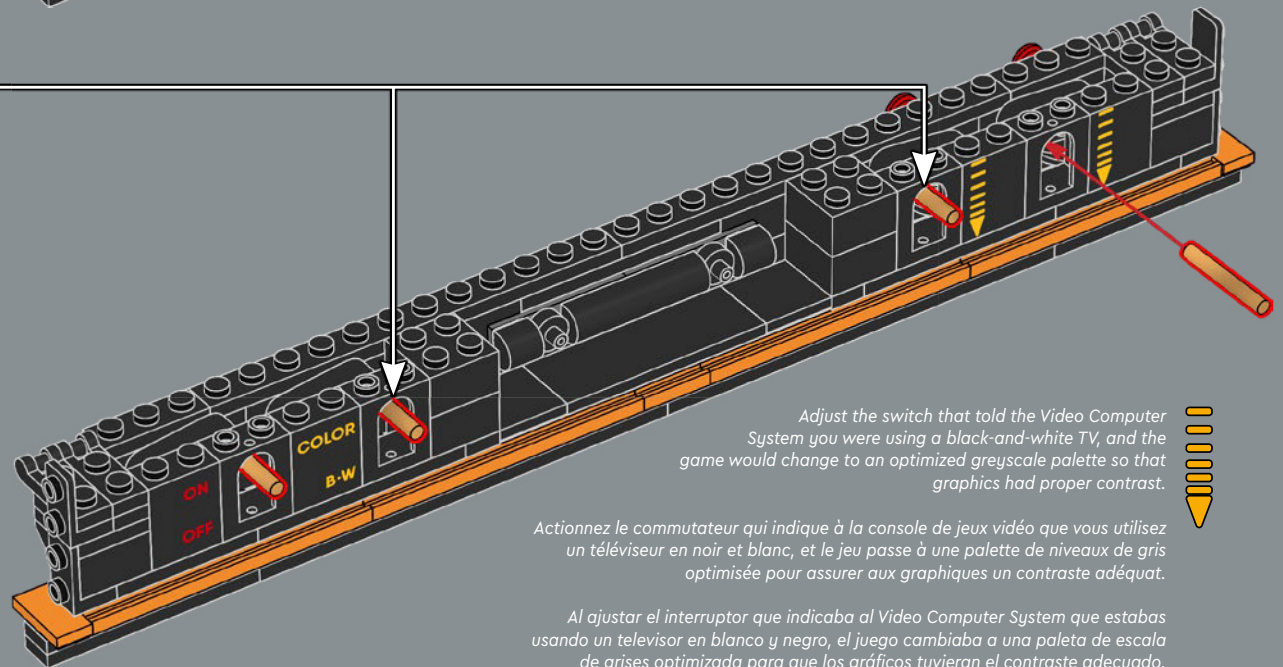
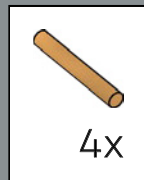

Adjust the switch that told the Video Computer System you were using a black-and-white TV, and the game would change to an optimized greyscale palette so that graphics had proper contrast.



Actionnez le commutateur qui indique à la console de jeux vidéo que vous utilisez un téléviseur en noir et blanc, et le jeu passe à une palette de niveaux de gris optimisée pour assurer aux graphiques un contraste adéquat.

Al ajustar el interruptor que indicaba al Video Computer System que estabas usando un televisor en blanco y negro, el juego cambiaba a una paleta de escala de grises optimizada para que los gráficos tuvieran el contraste adecuado.

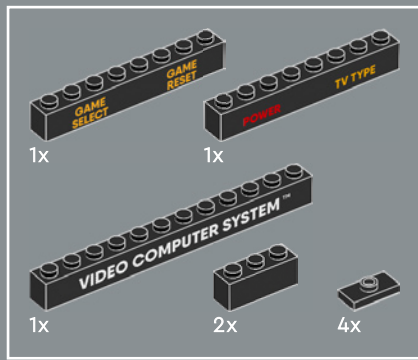

241

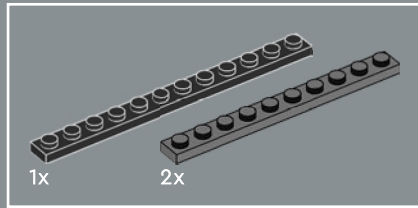
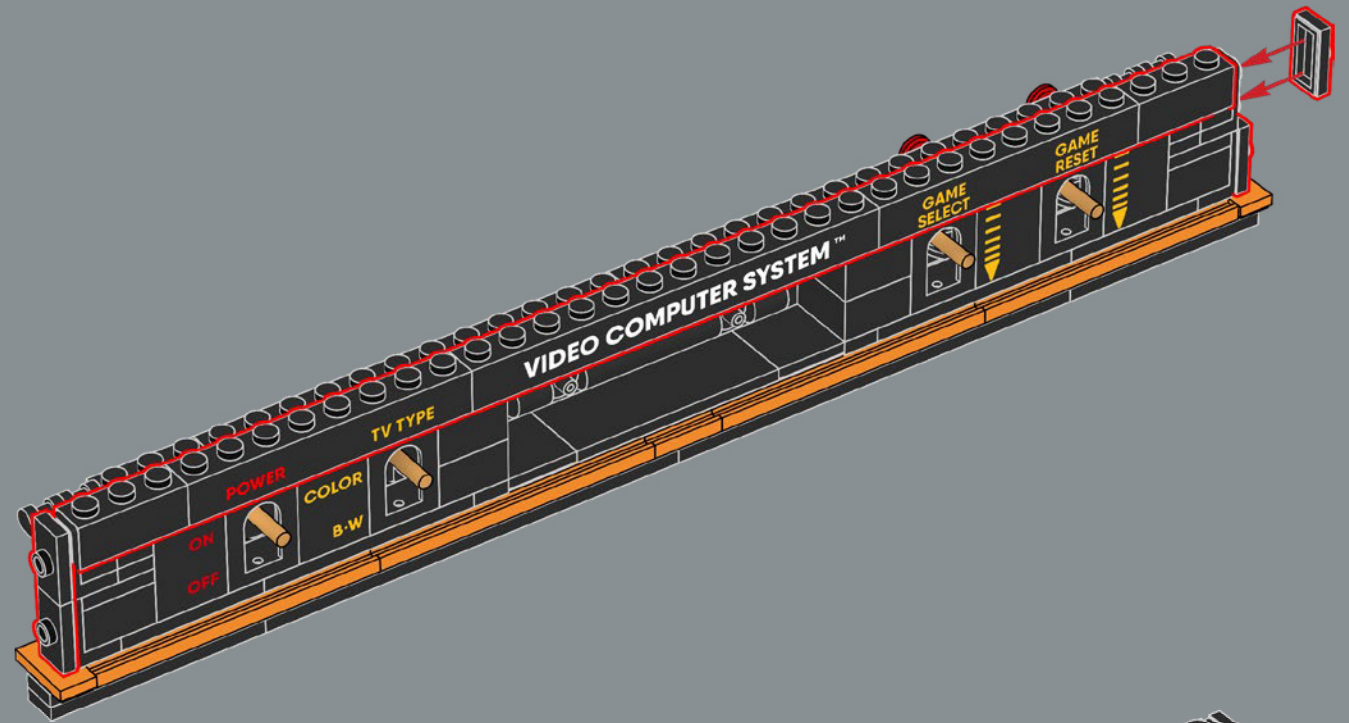

242

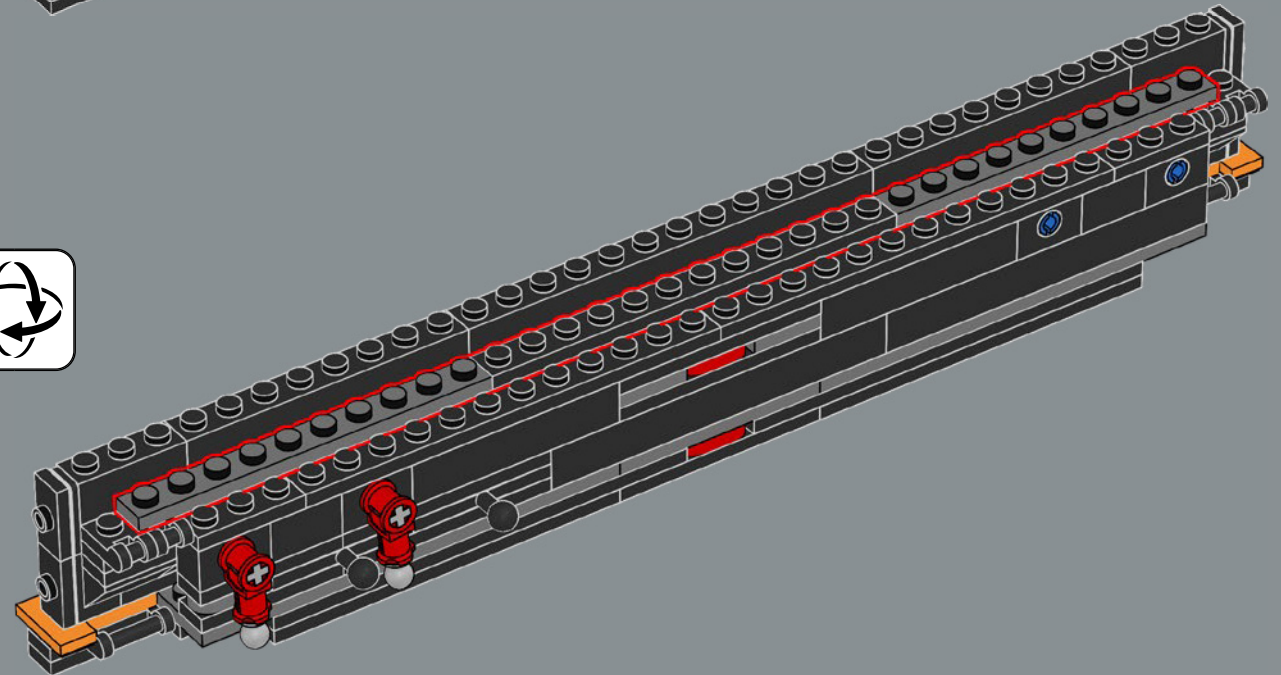

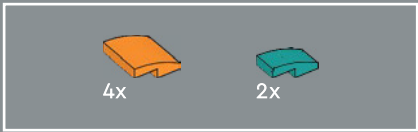

243

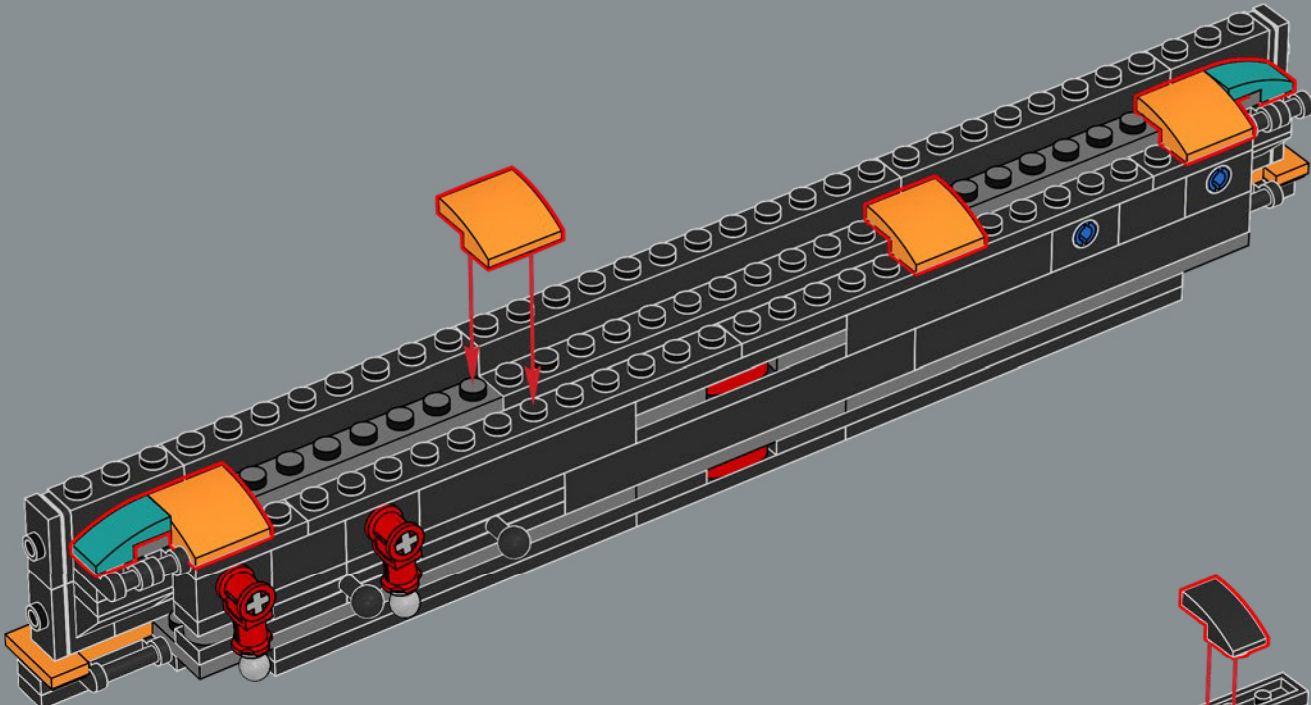

244



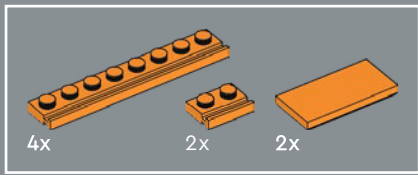

245

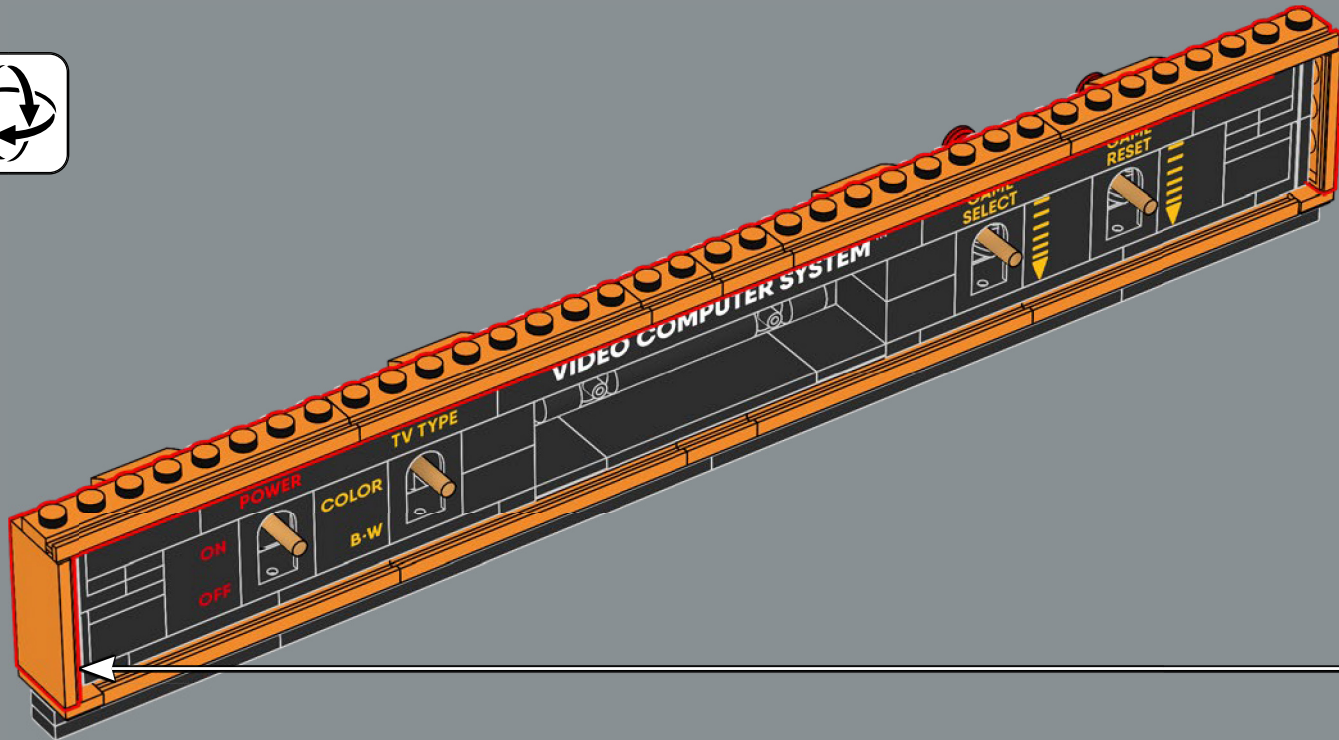
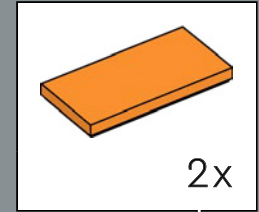



246

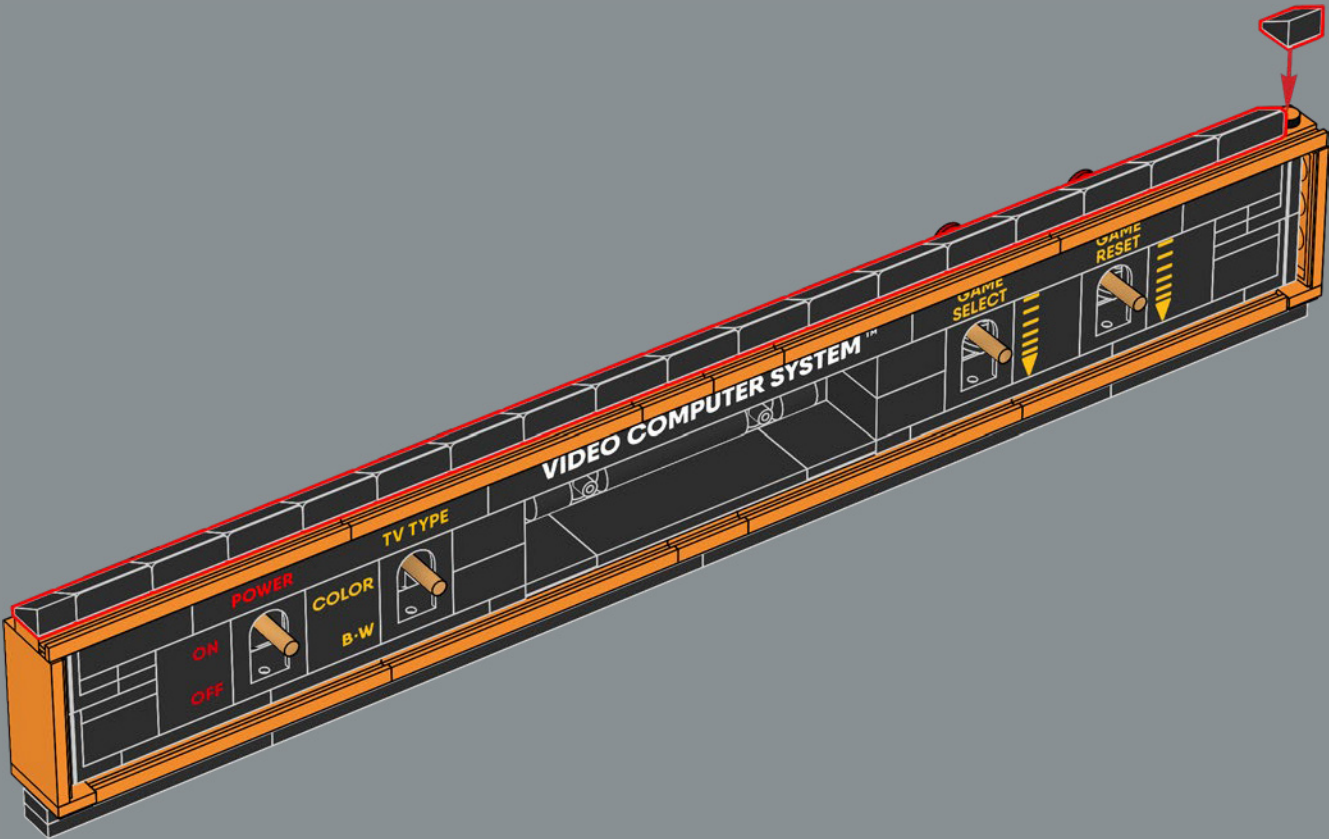



247

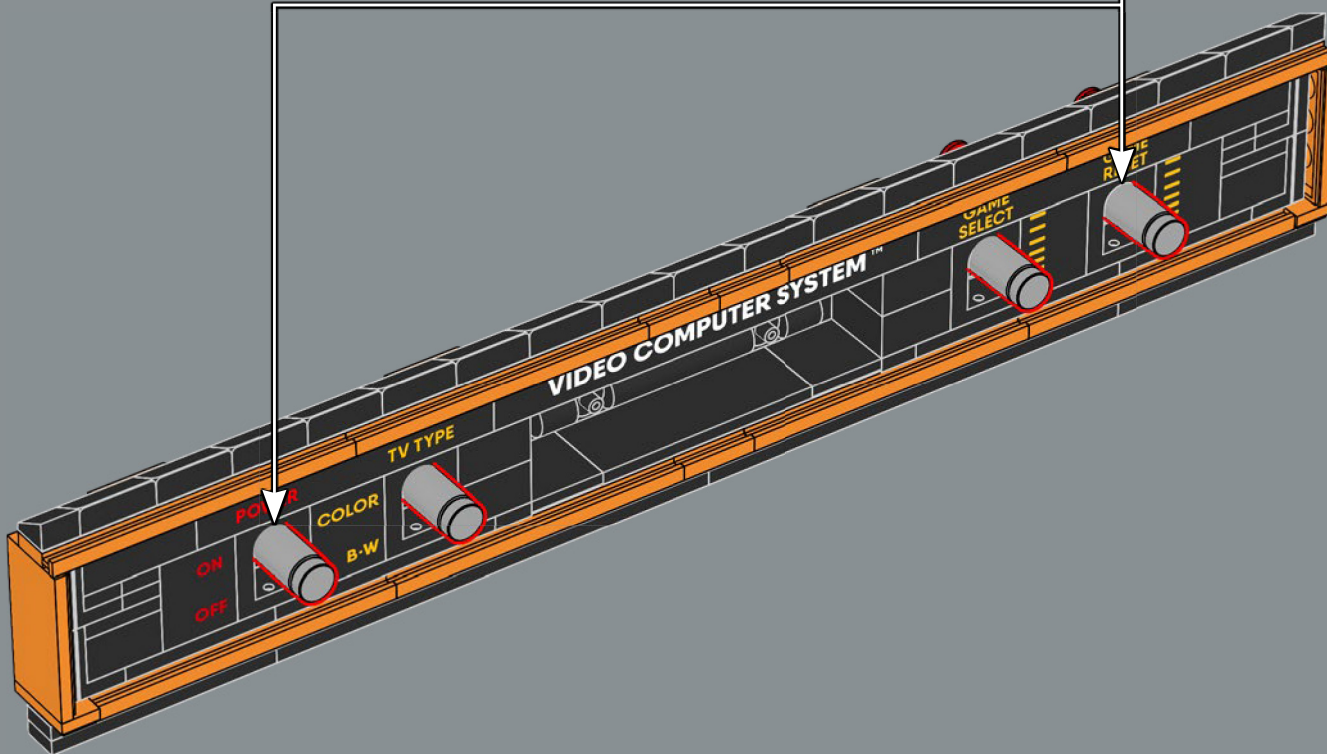
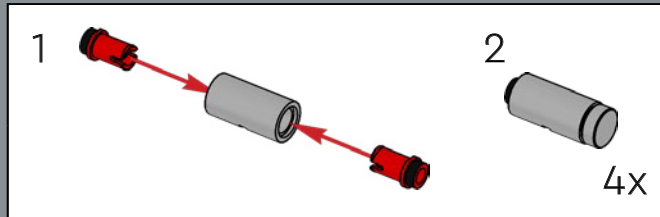



2x



2x



2x



2x



4x



2x



4x



4x



4x

248

1

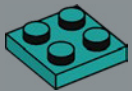

2

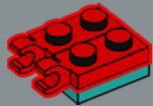

3

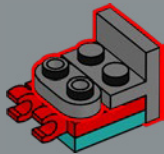

4

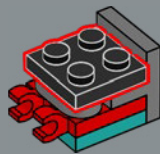

5

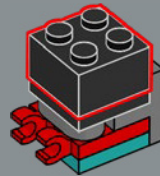

6

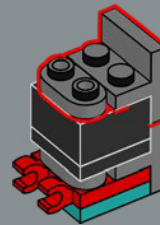

7

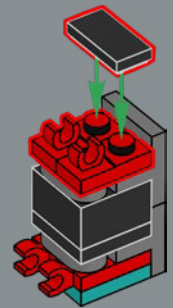

2x

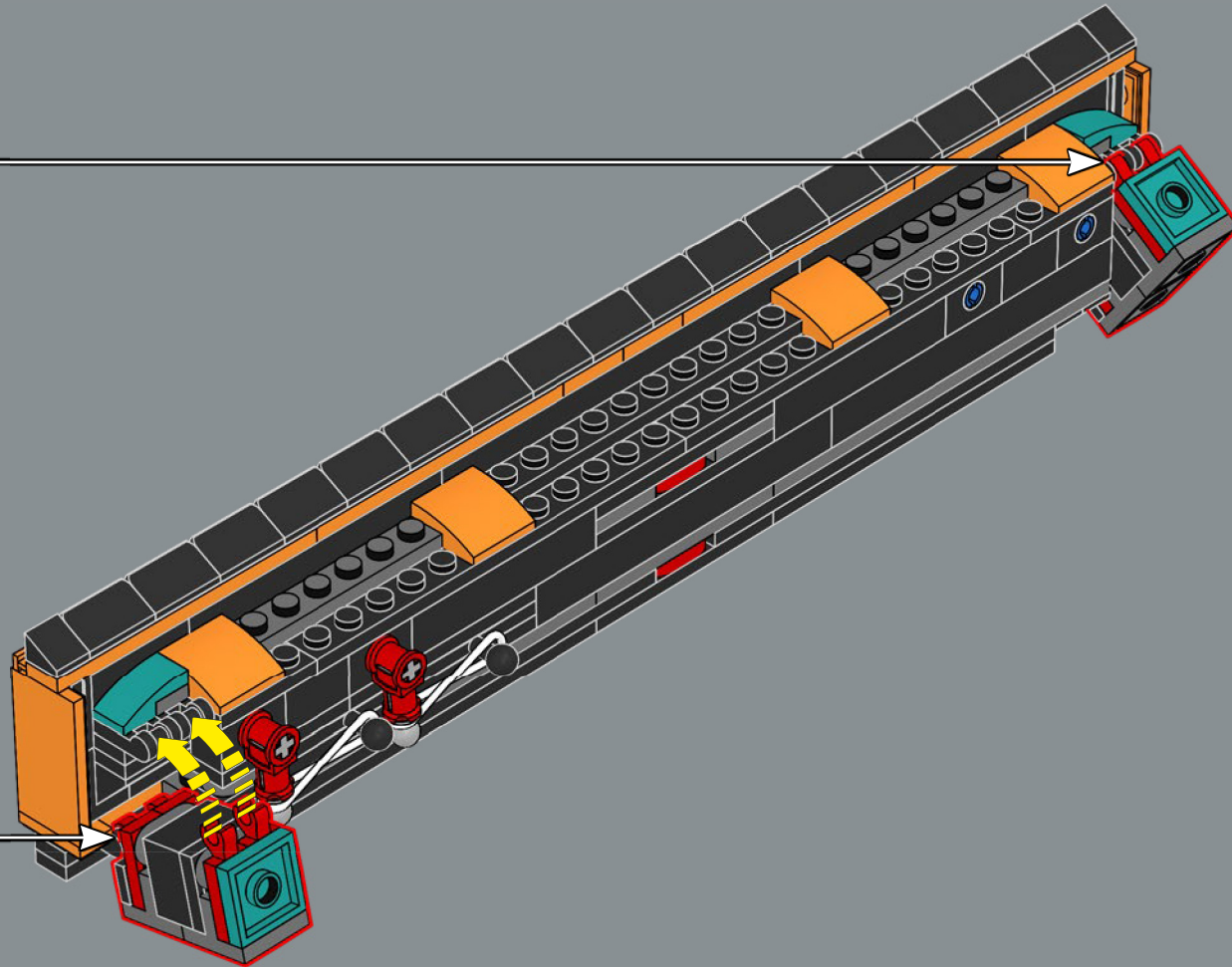

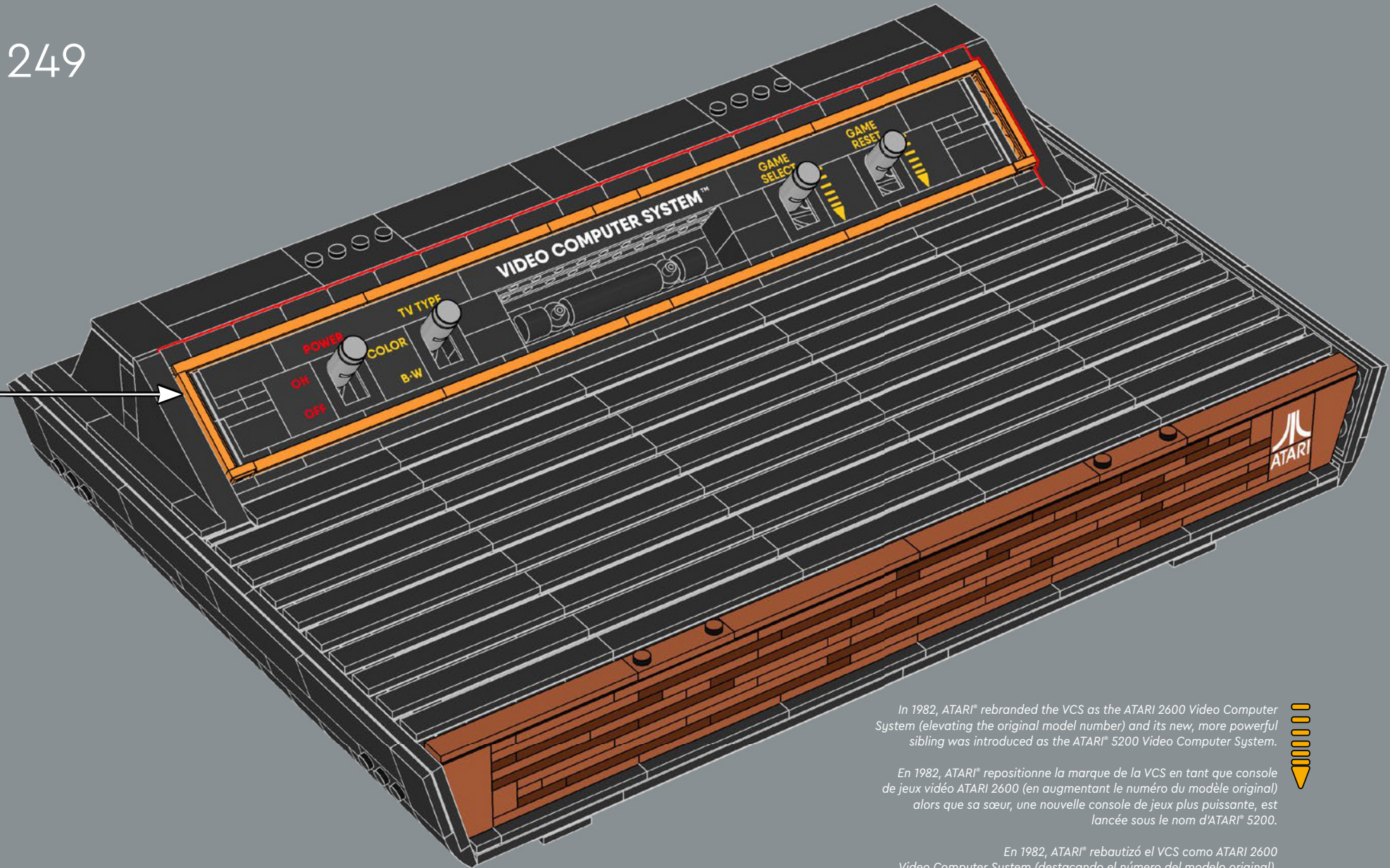

In 1982, ATARI® rebranded the VCS as the ATARI 2600 Video Computer System (elevating the original model number) and its new, more powerful sibling was introduced as the ATARI® 5200 Video Computer System.

En 1982, ATARI® repositionne la marque de la VCS en tant que console de jeux vidéo ATARI 2600 (en augmentant le numéro du modèle original) alors que sa sœur, une nouvelle console de jeux plus puissante, est lancée sous le nom d'ATARI® 5200.

En 1982, ATARI® rebautizó el VCS como ATARI 2600 Video Computer System (destacando el número del modelo original), y su nuevo y más potente hermano fue presentado como ATARI® 5200 Video Computer System.



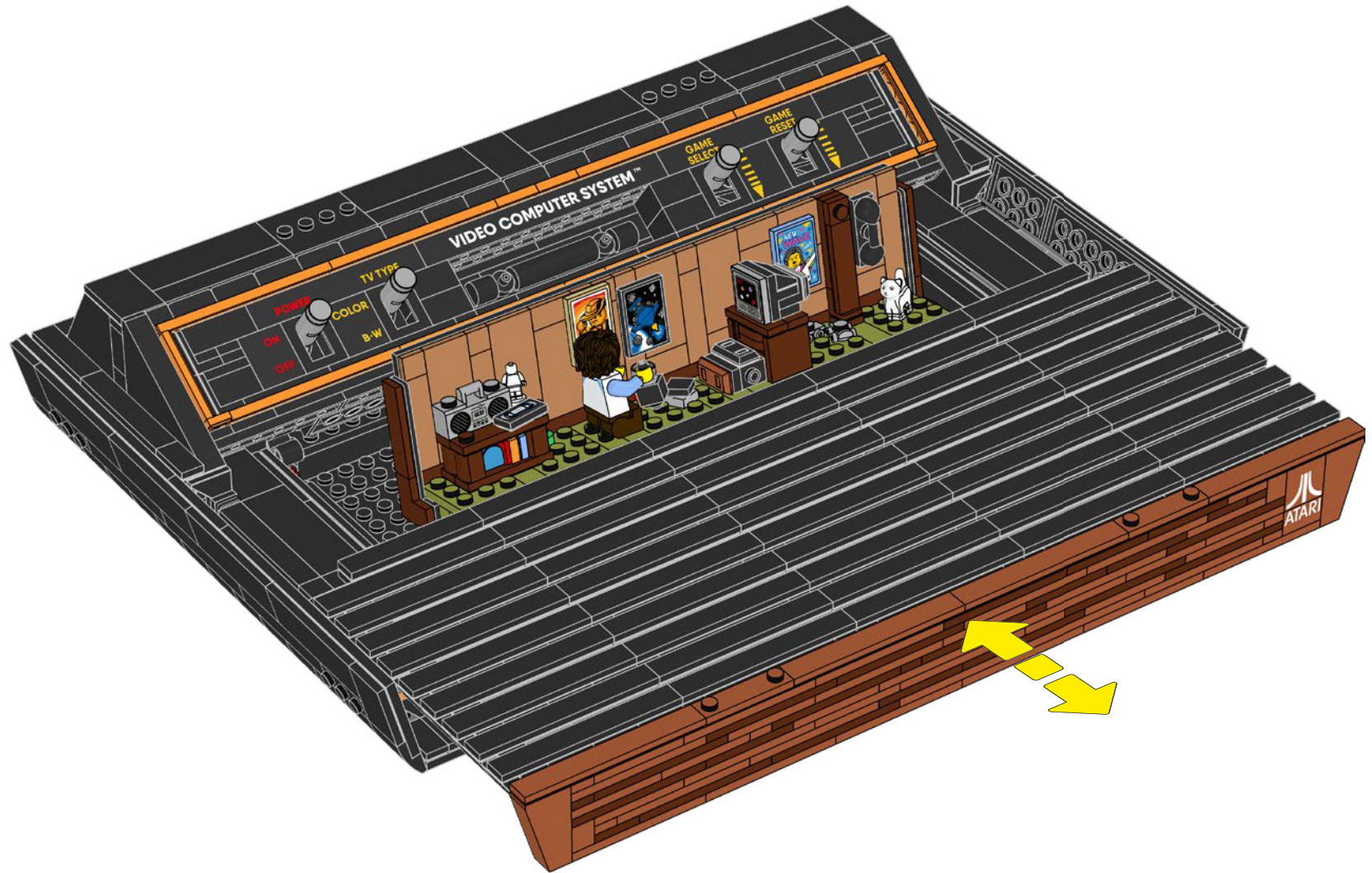

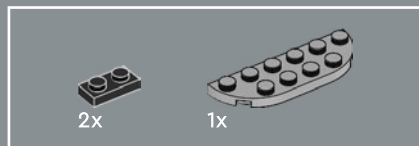
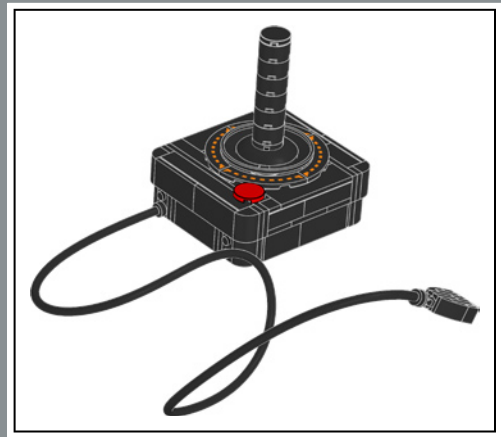
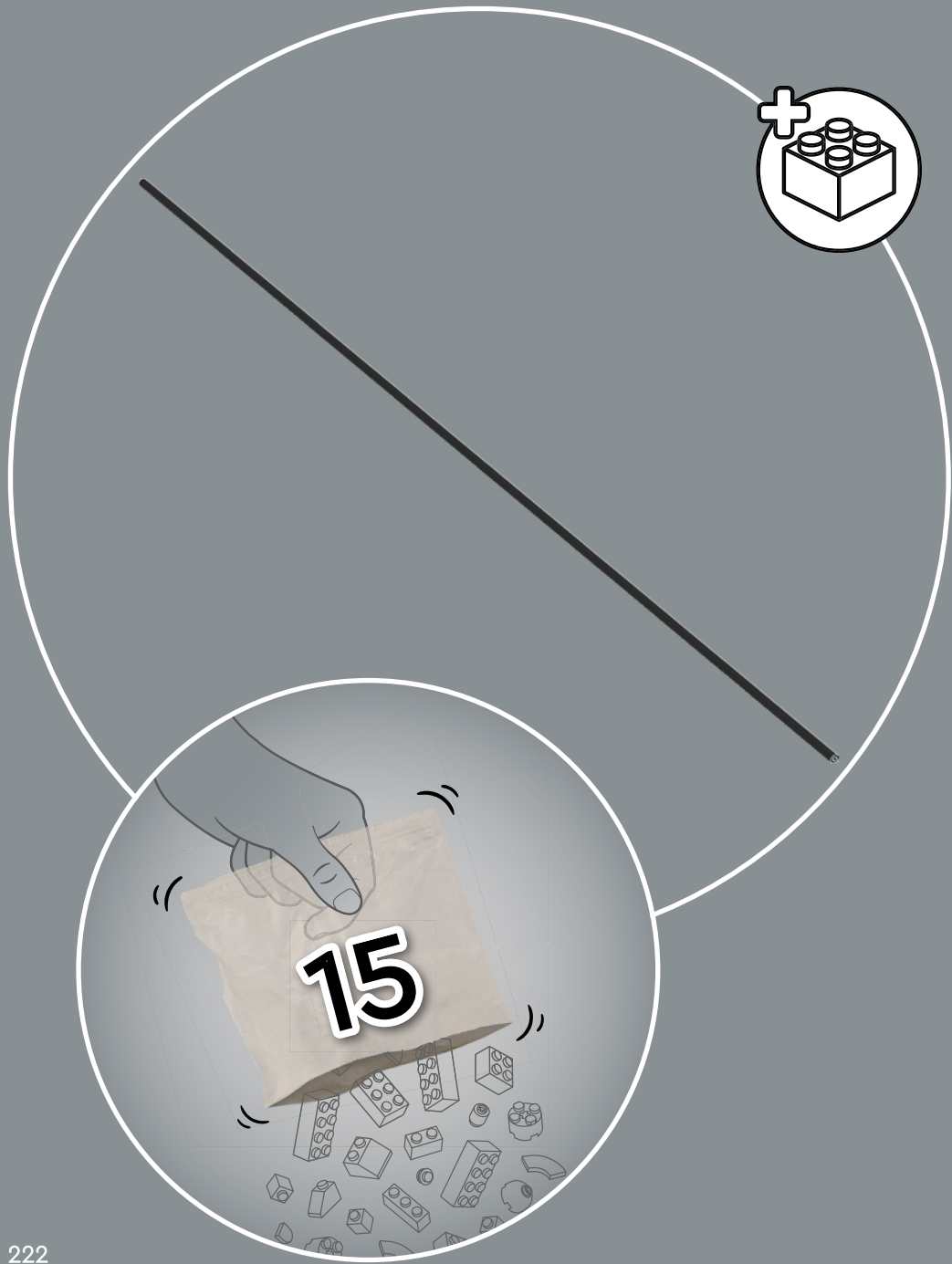

1

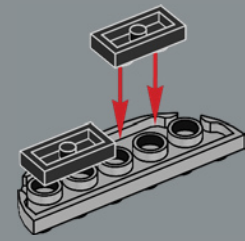

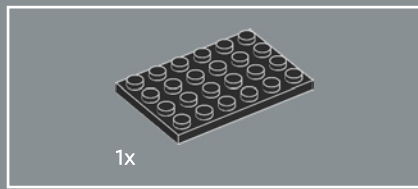

2

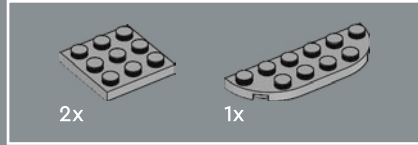
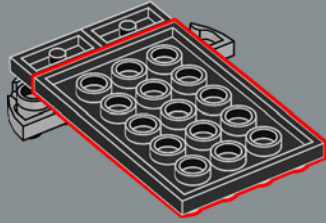

3

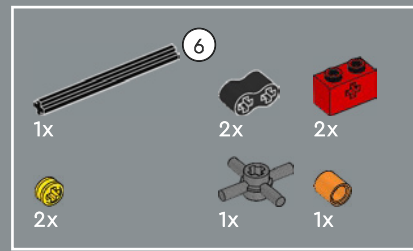
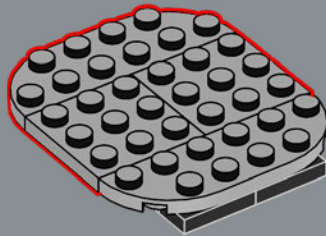

4

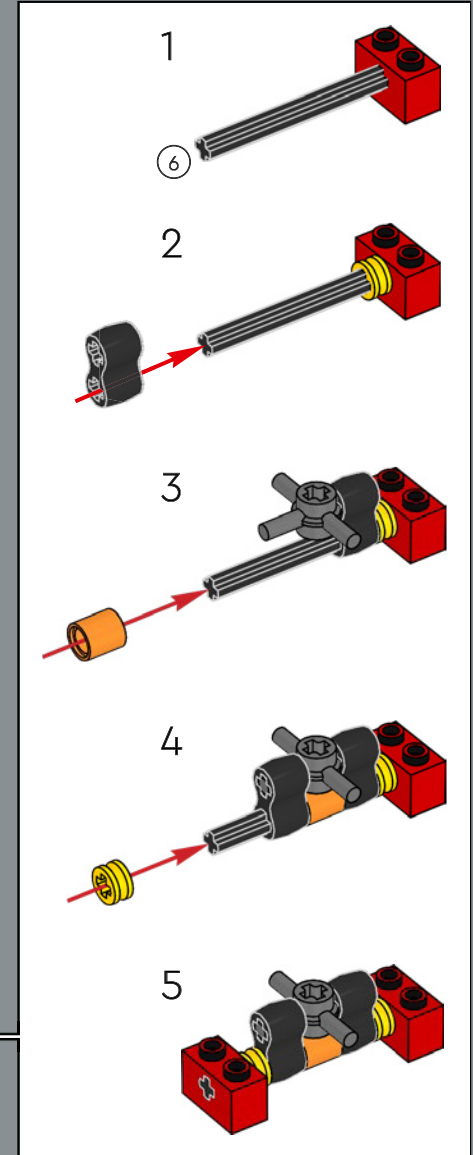
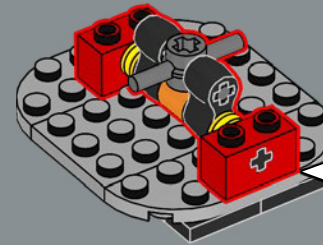

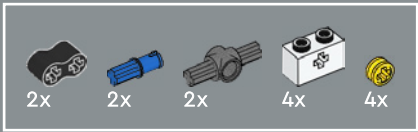

5

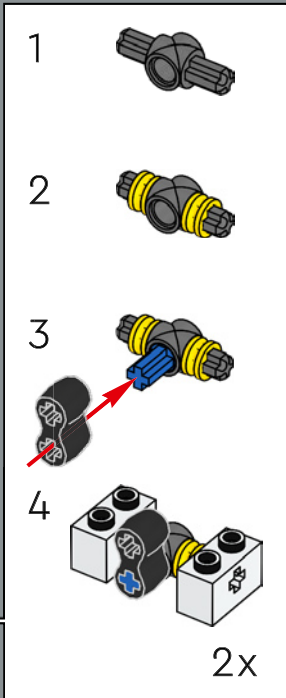
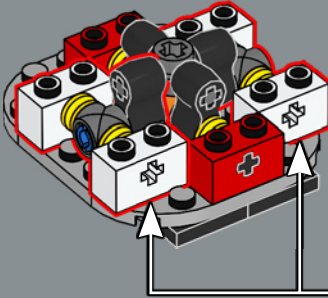

6

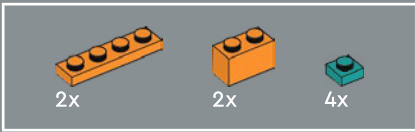
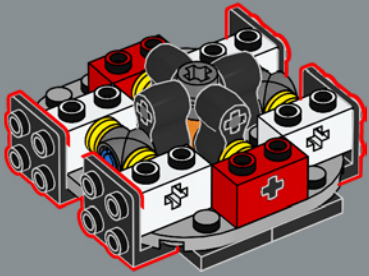

7

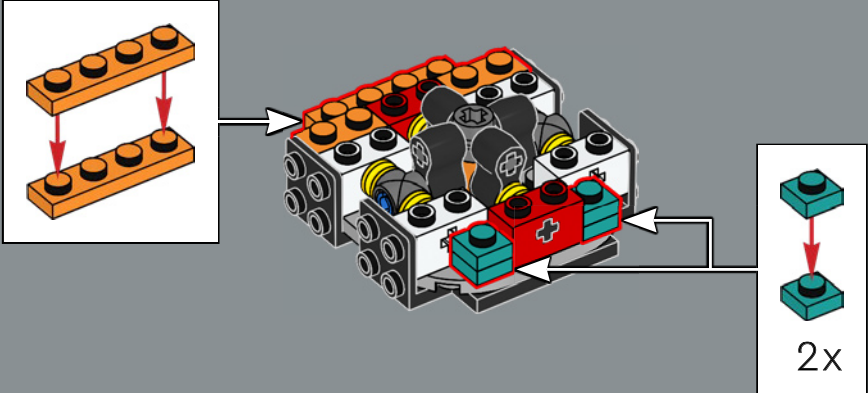

8

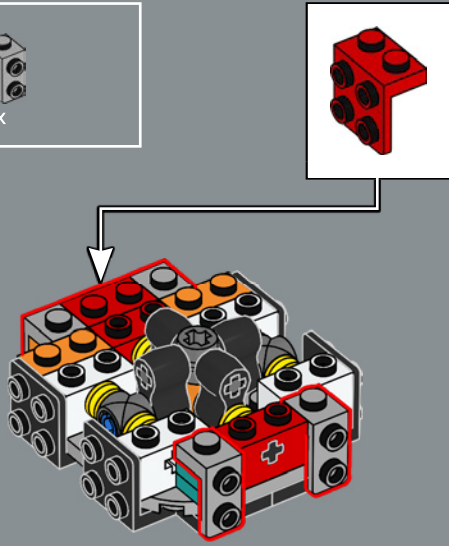

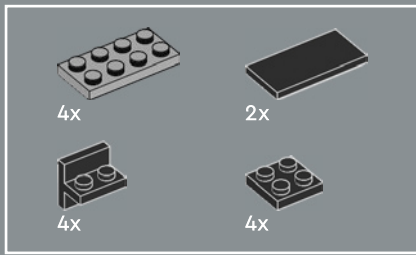

9

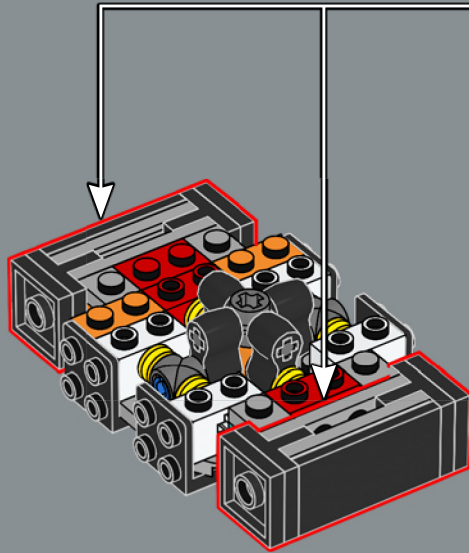
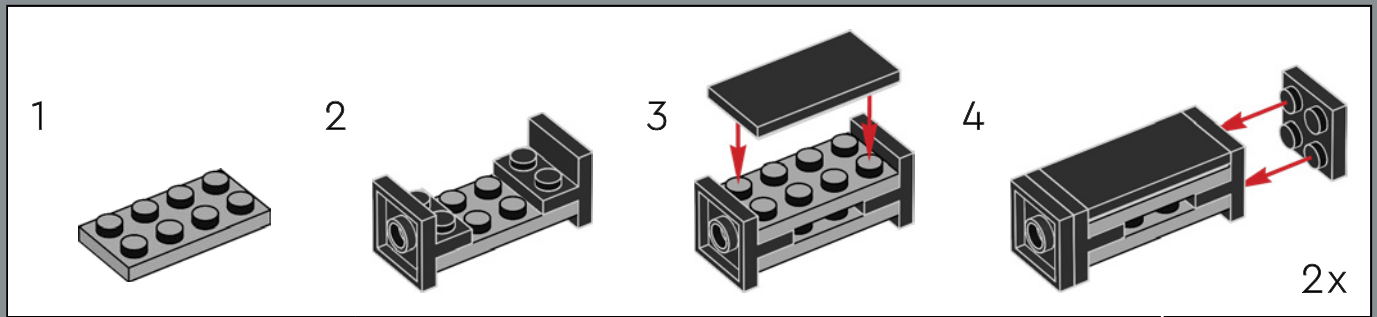

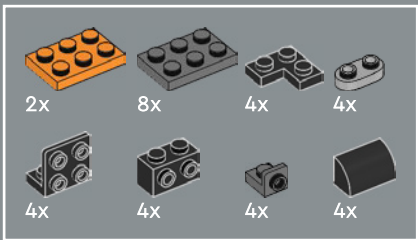

10

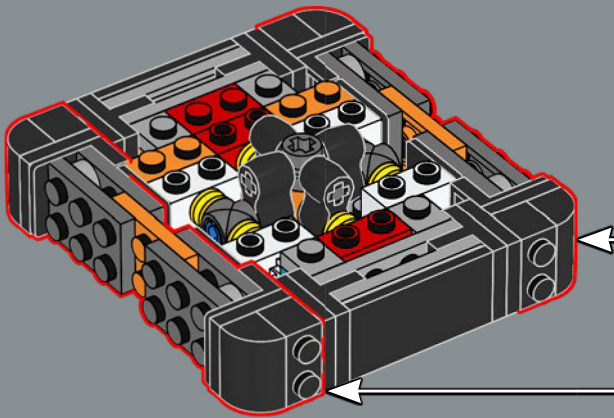
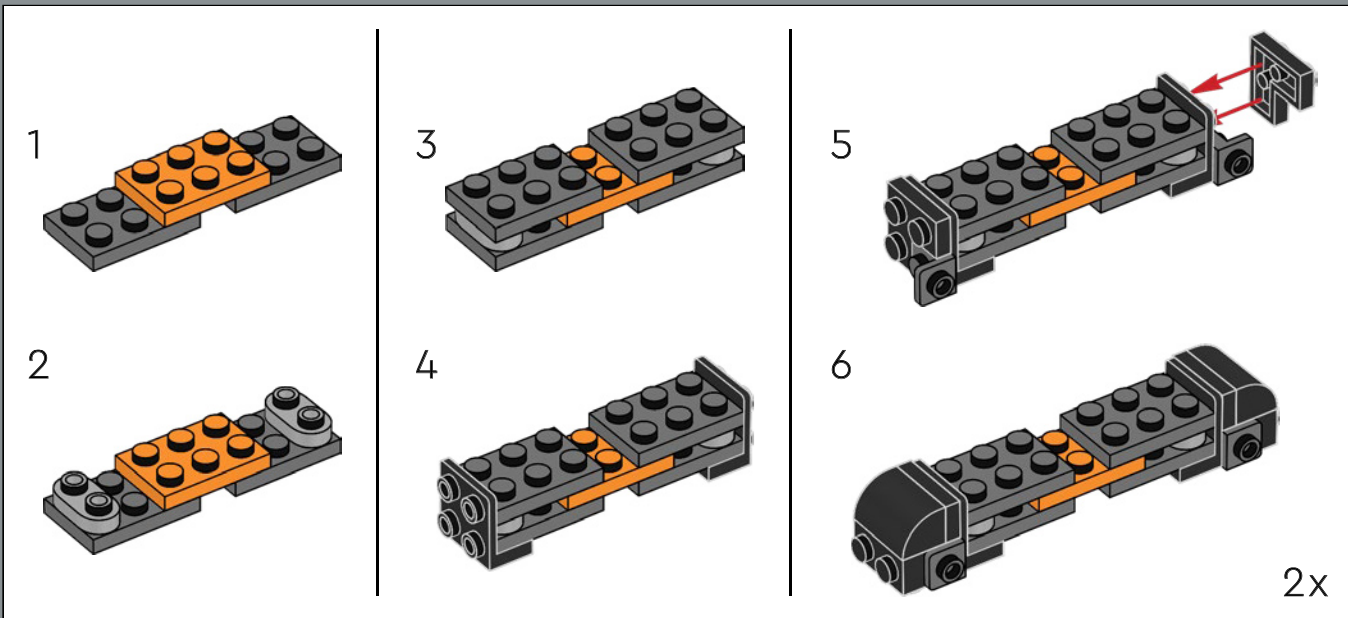

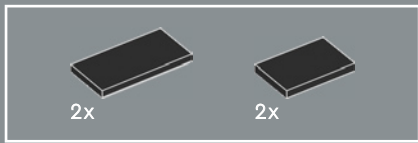

11

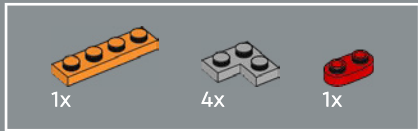
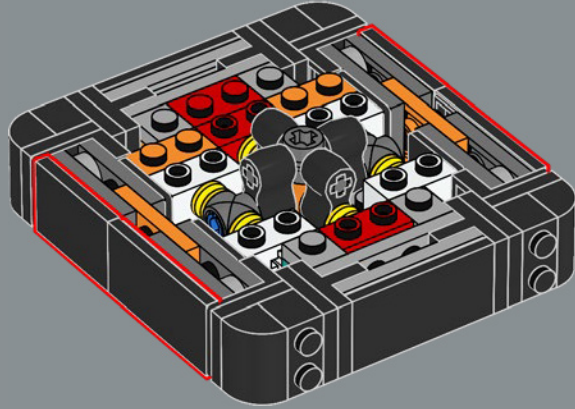

12

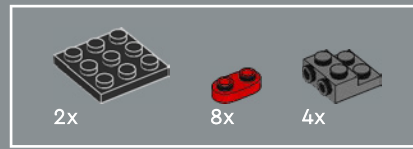
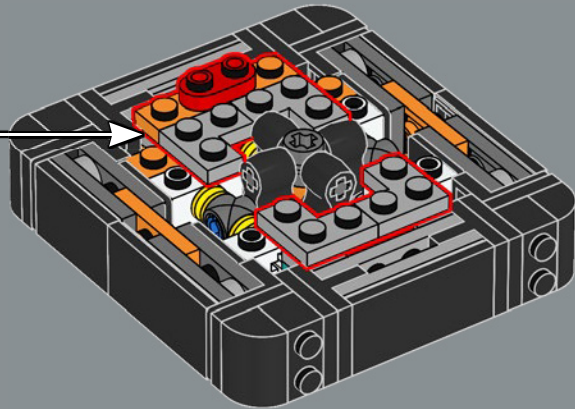
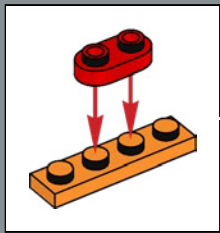

13

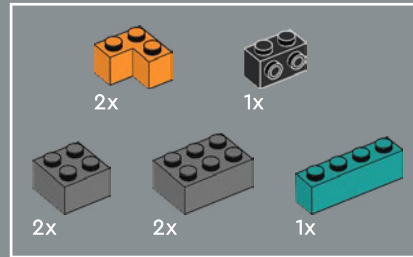
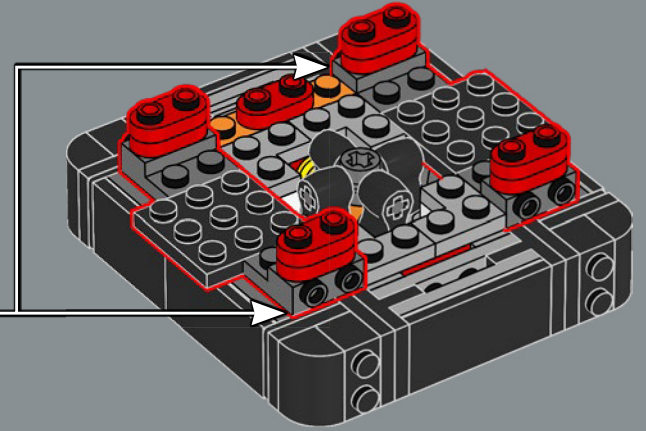
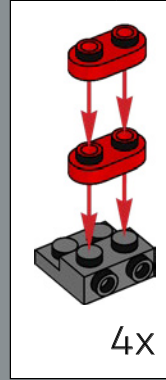

14

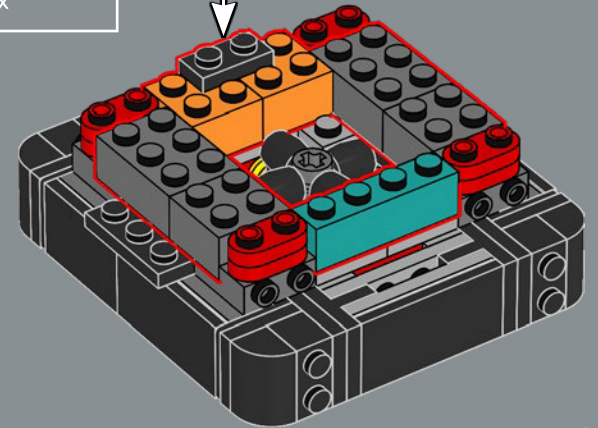
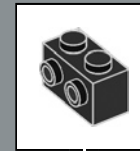

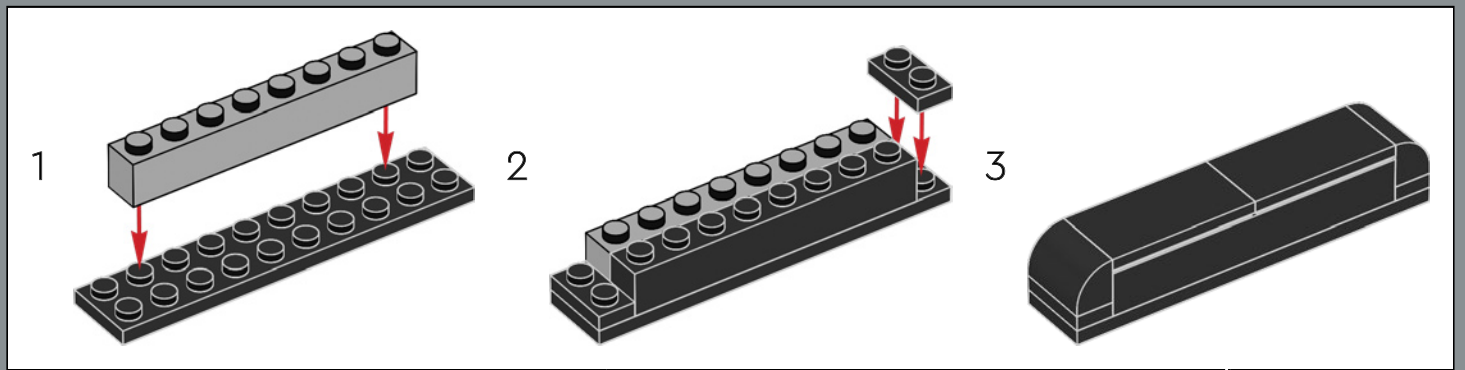
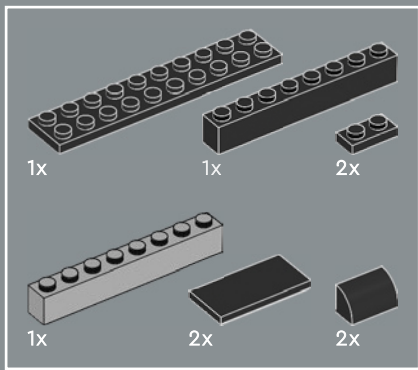

15

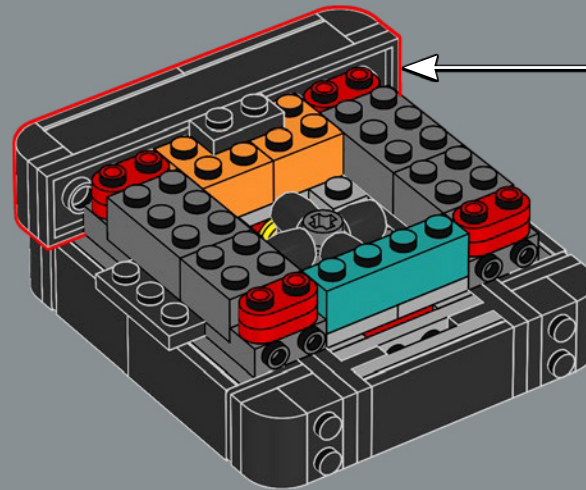

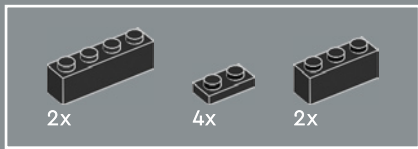

16

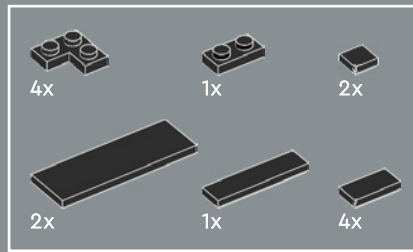
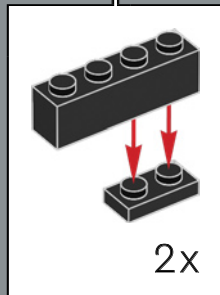
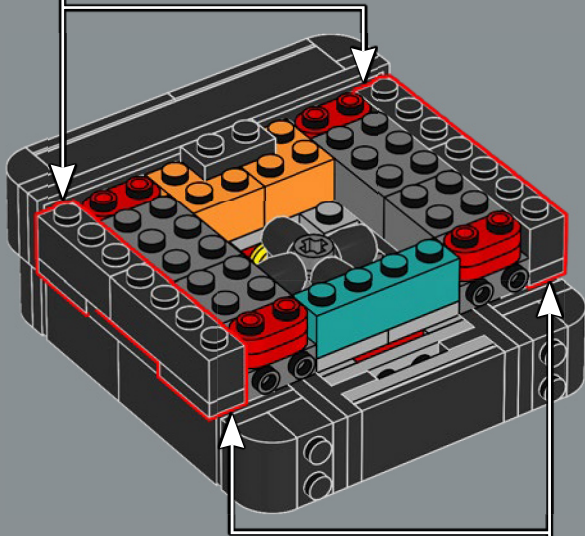
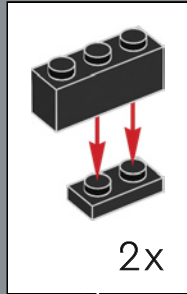

17

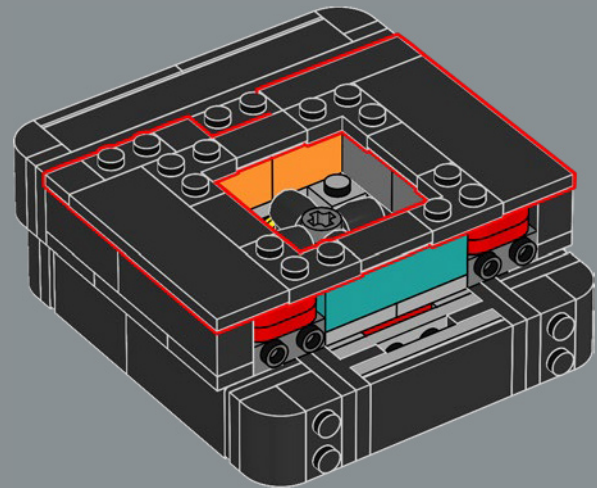

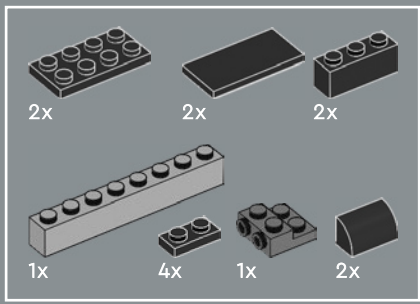

18

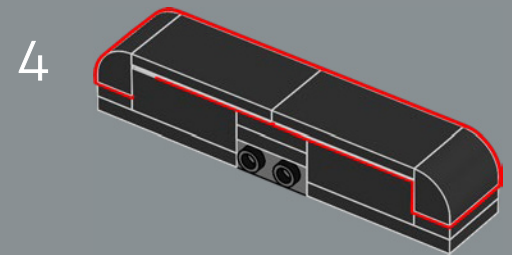
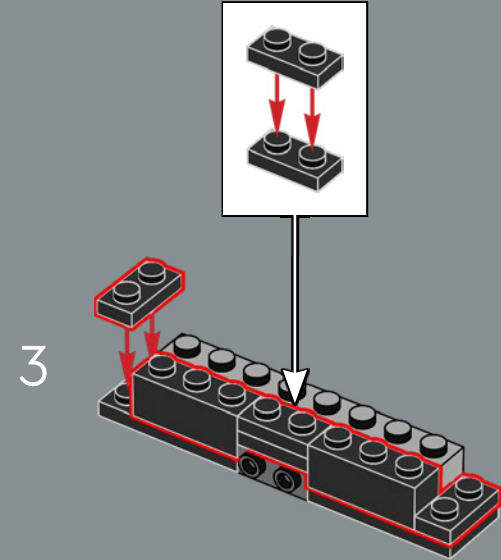
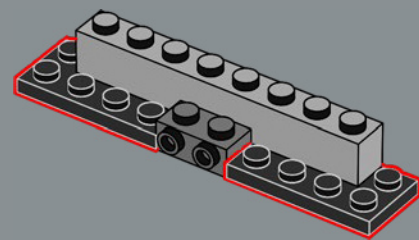
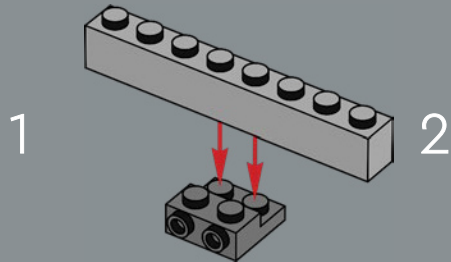

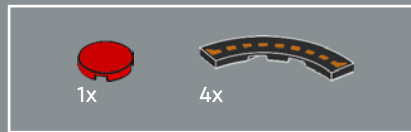

19

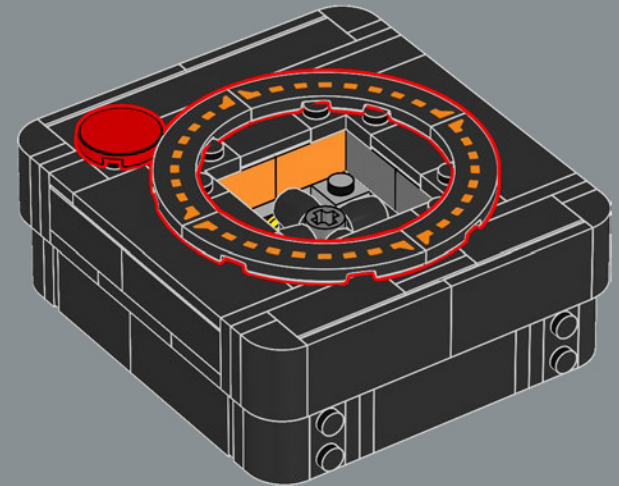
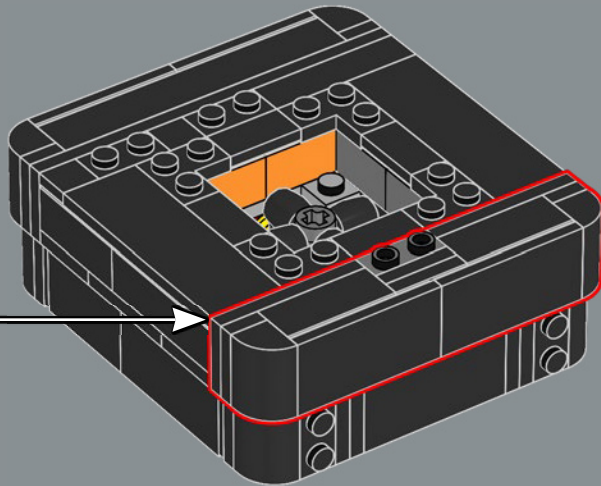

The ATARI® Video Computer System joystick is so iconic that its shape and bright red button is often used in graphical icons to represent gaming.

La manette de la console de jeux vidéo ATARI® est tellement emblématique que sa forme et son bouton rouge vif sont souvent utilisés pour symboliser le jeu vidéo.

El control del ATARI® Video Computer System es tan inconfundible que su forma y su llamativo botón rojo se usan frecuentemente en los íconos gráficos que representan los juegos.

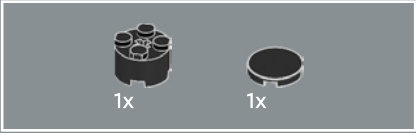
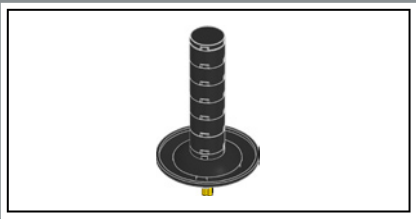

20

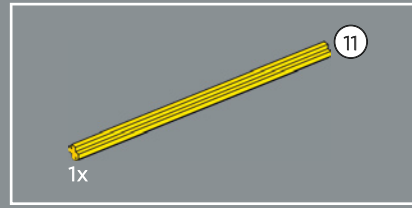

21





22

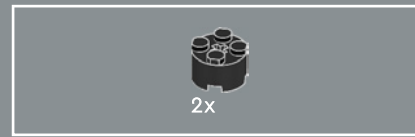
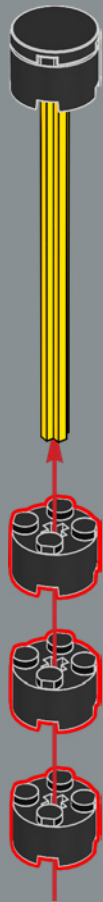

23

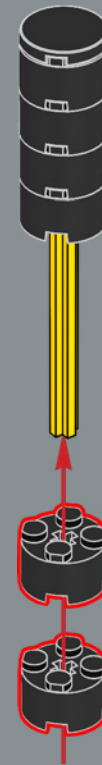

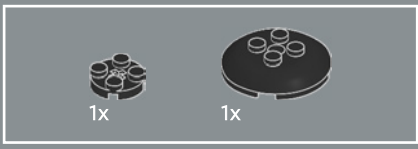

24

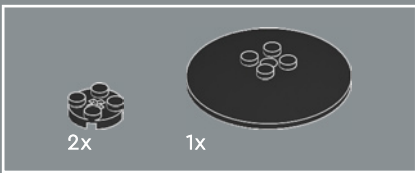
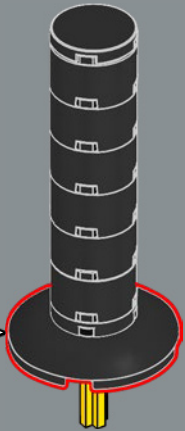
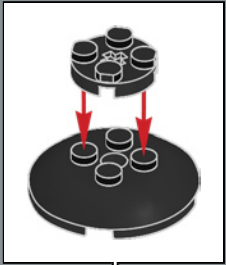

25

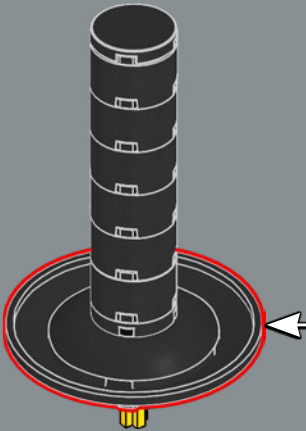
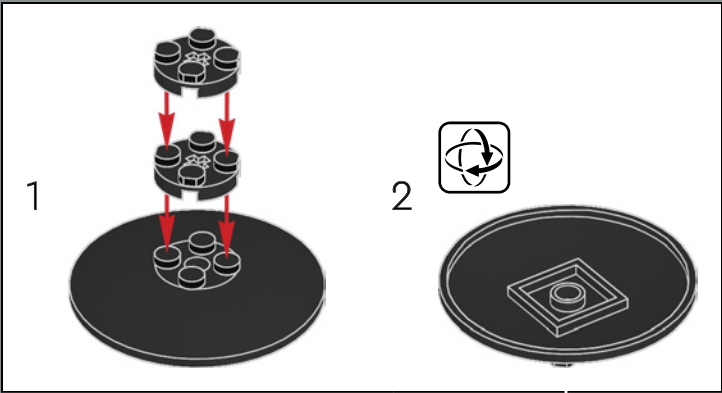

26

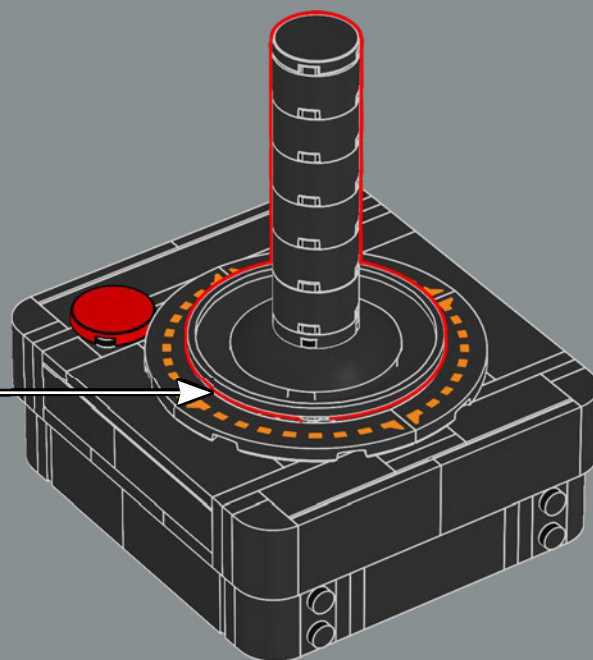

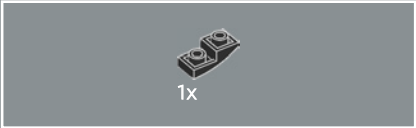
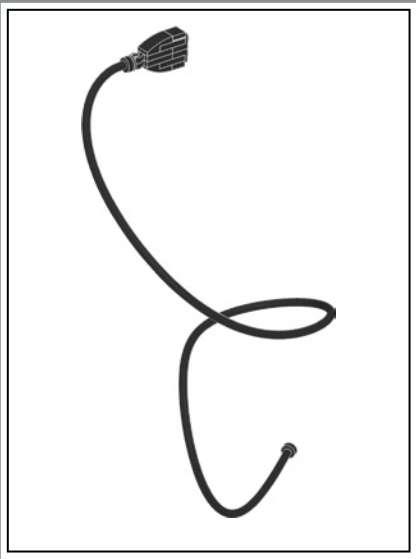

27

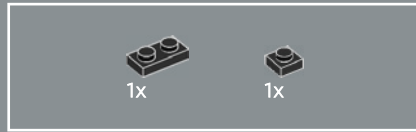
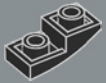

28

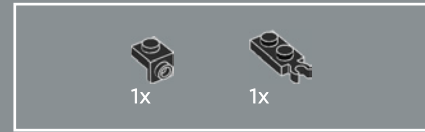
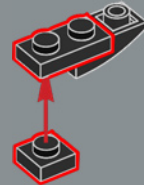

29

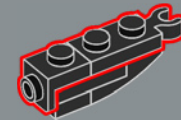



30

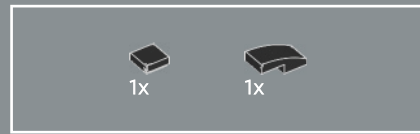
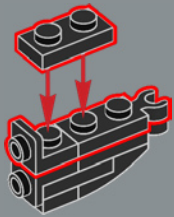

31

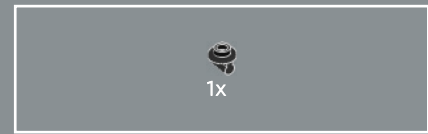
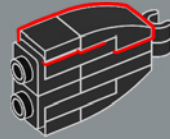

32

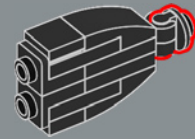



2x

33



2x

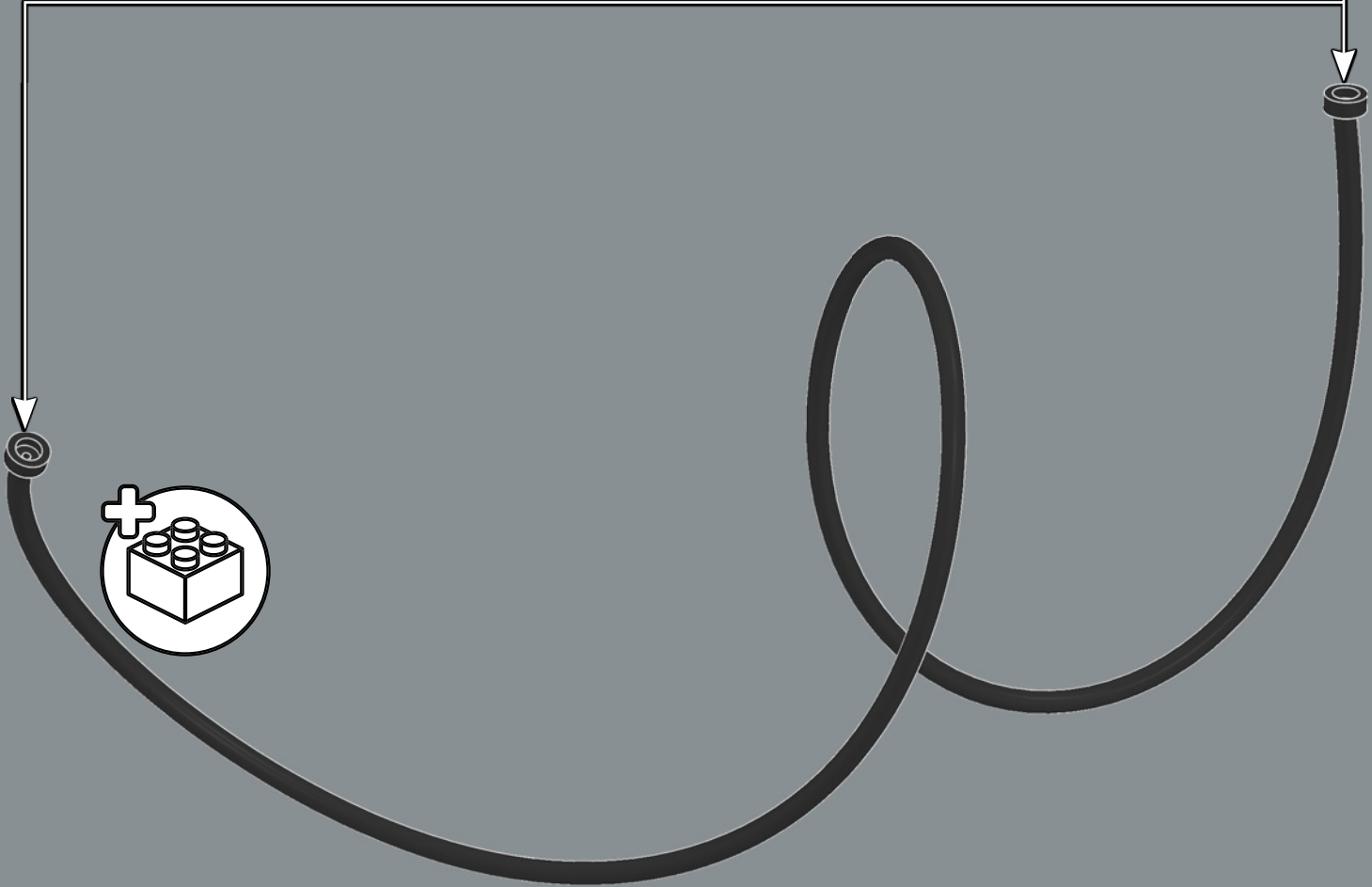

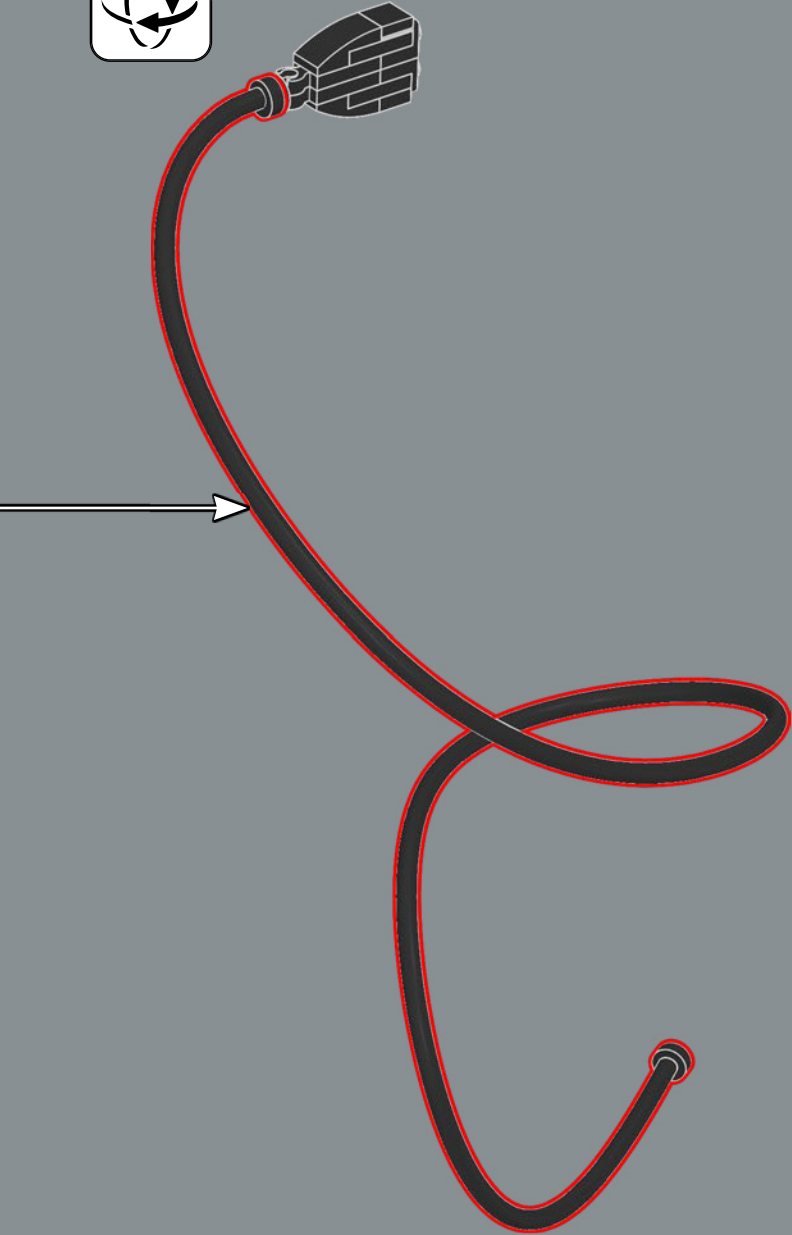

34

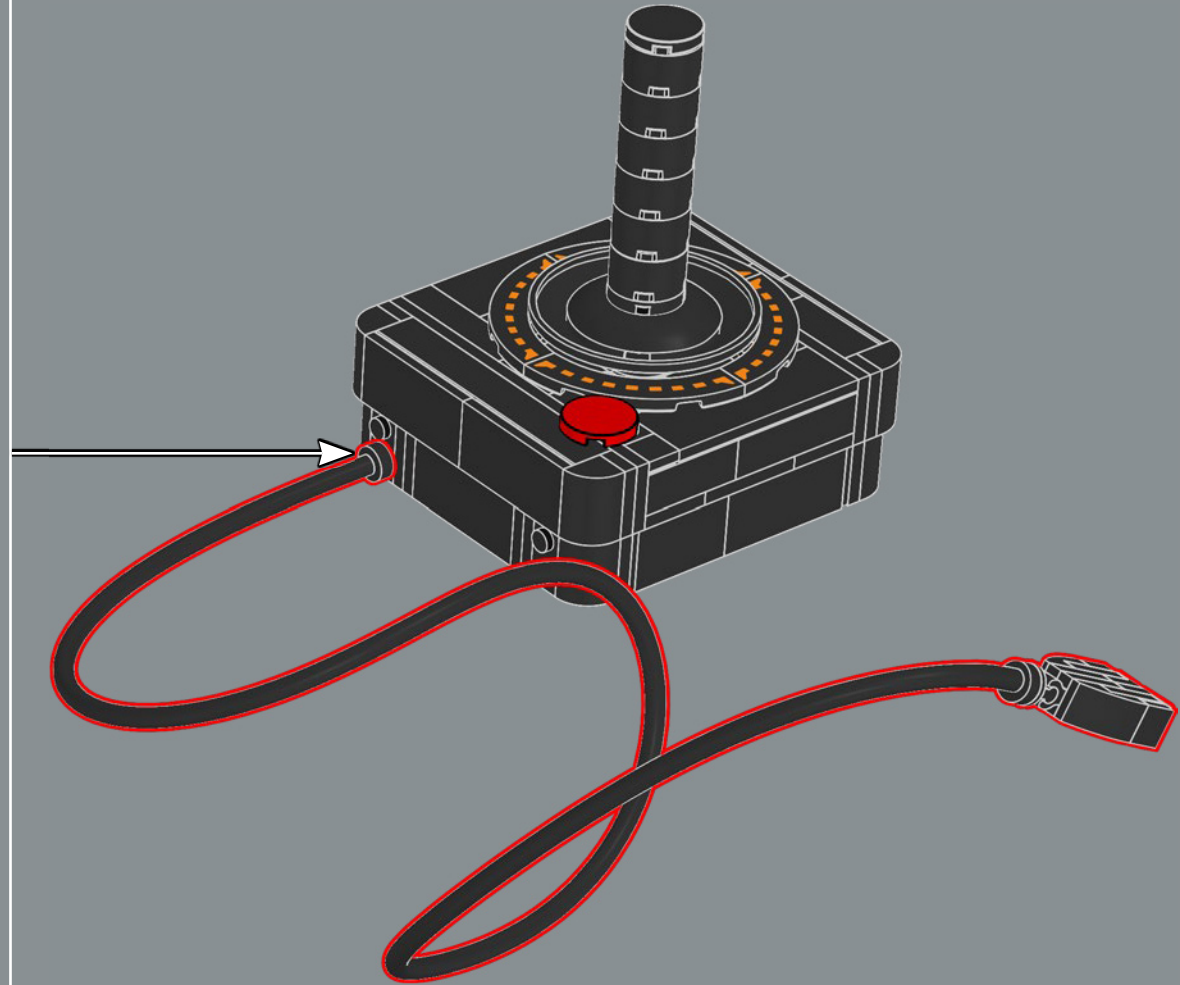

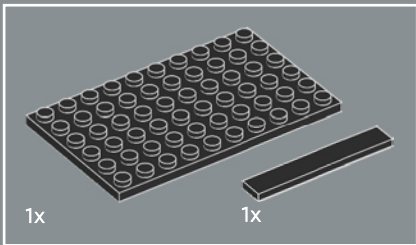

1

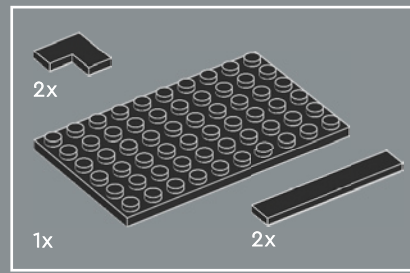
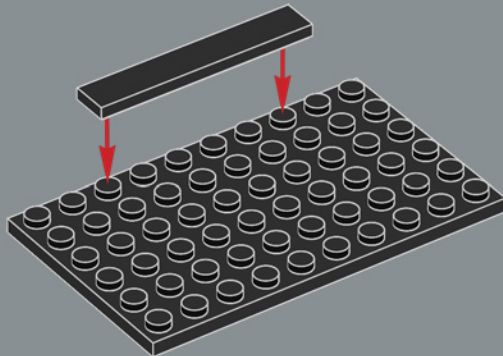

2

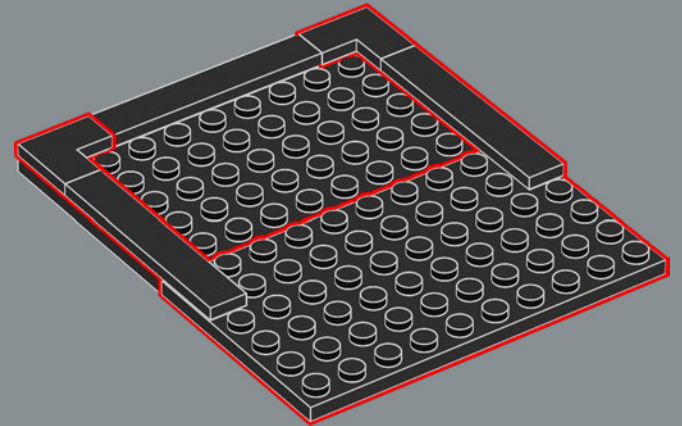

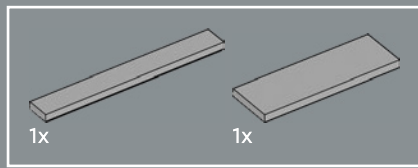

3

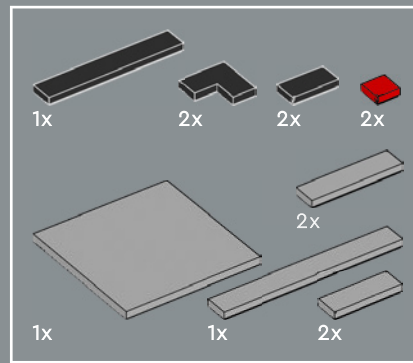
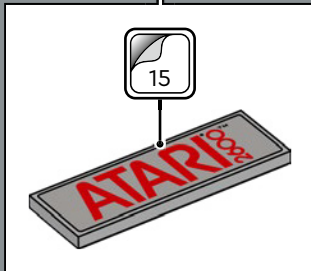
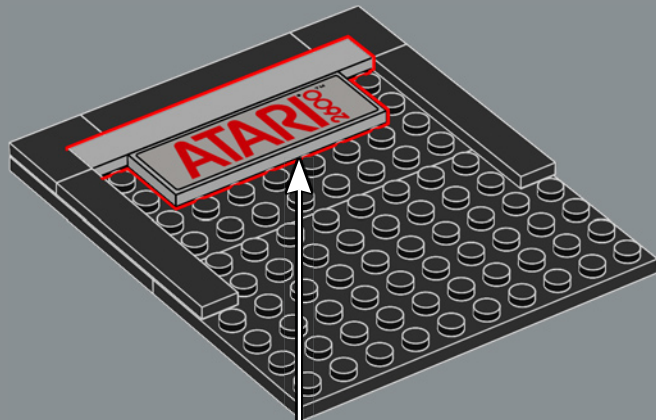

4

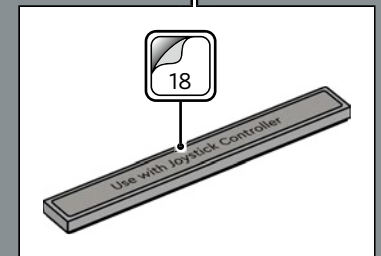

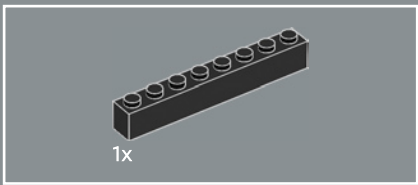

5

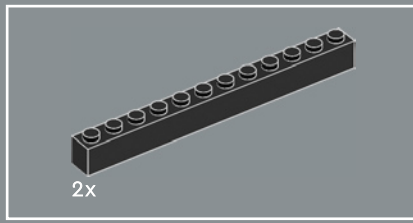
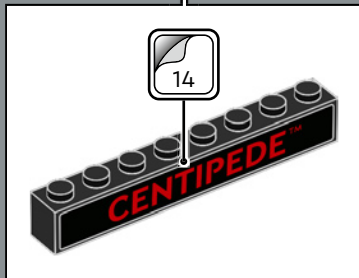

6

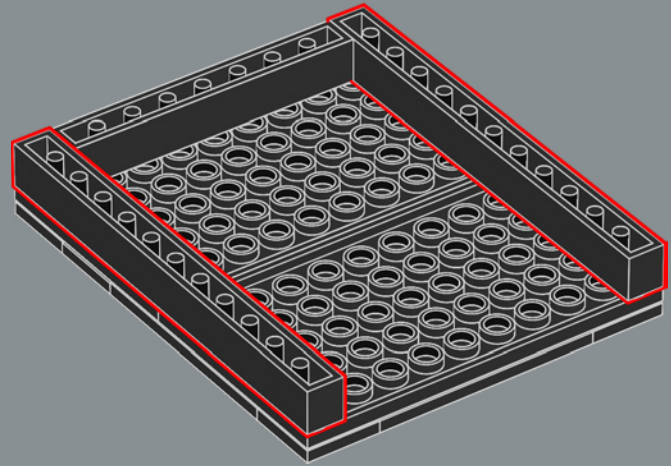

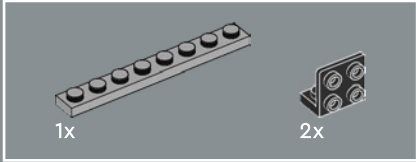
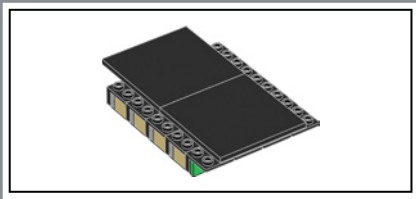

7

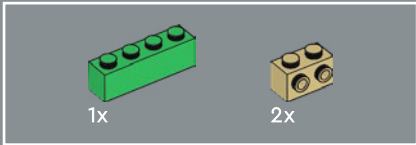
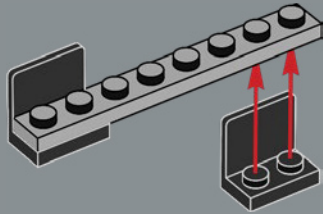

8

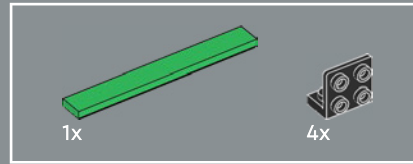
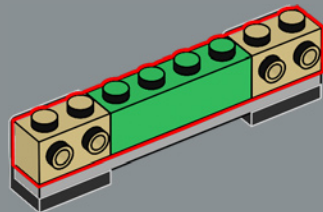

9

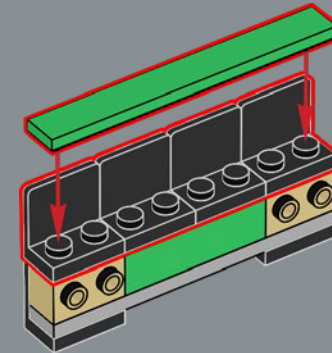

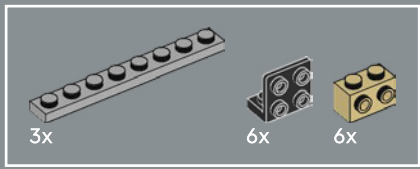

10

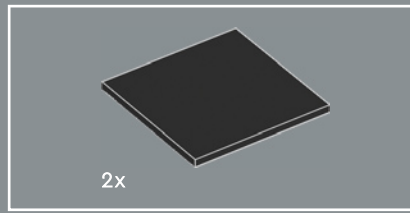
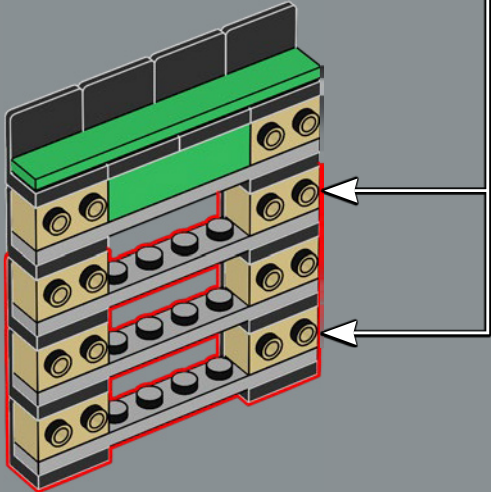
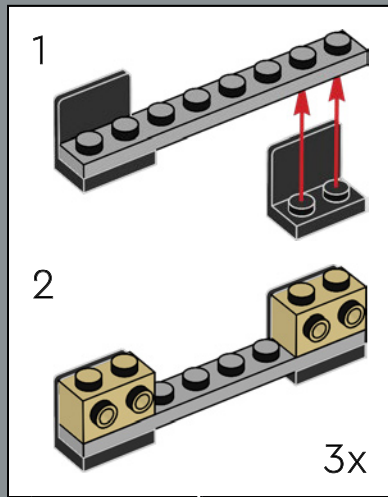

11

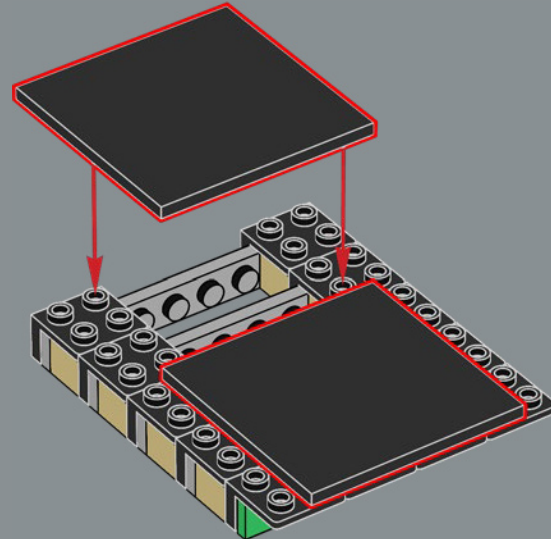

12

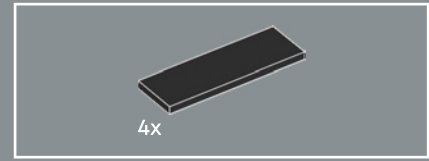
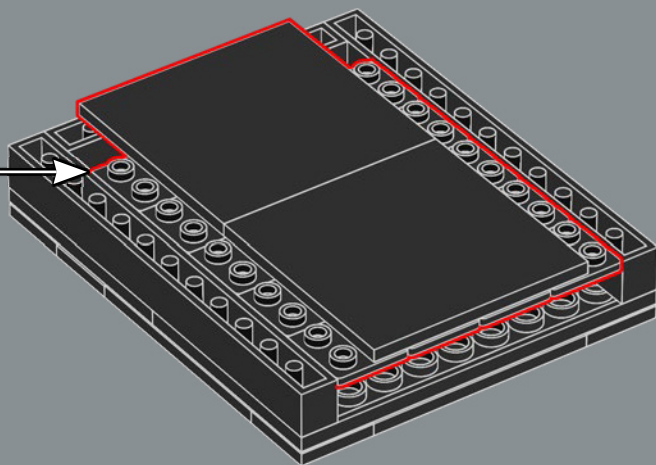

13

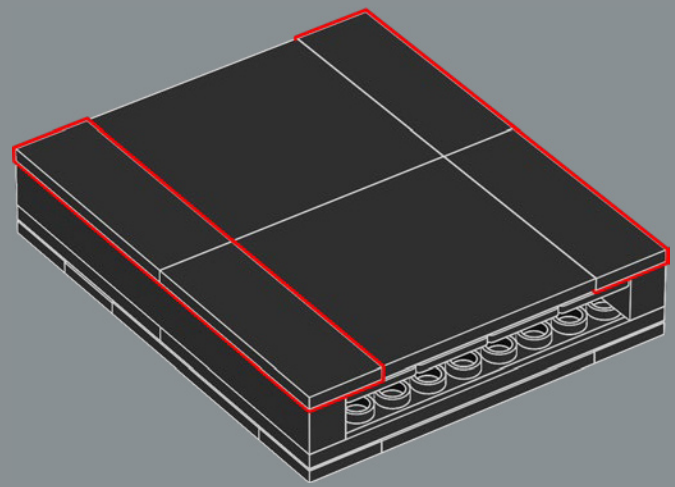

14



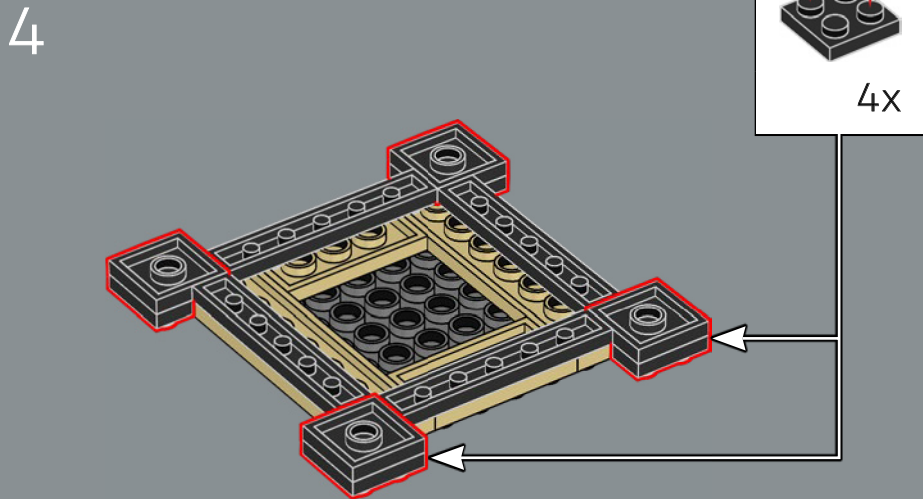
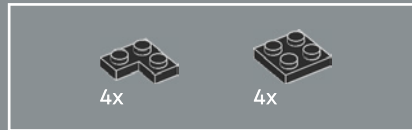
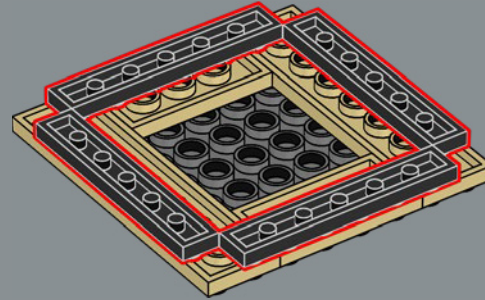
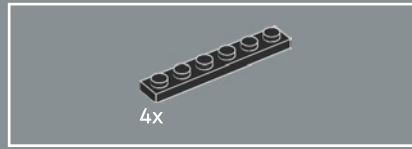
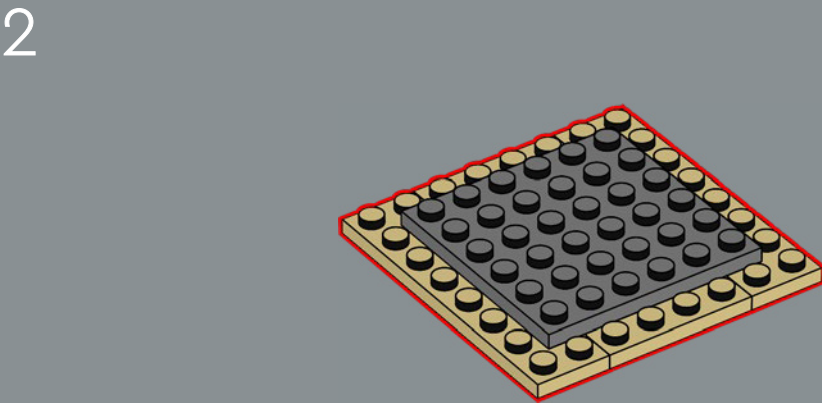
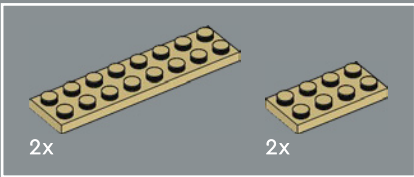
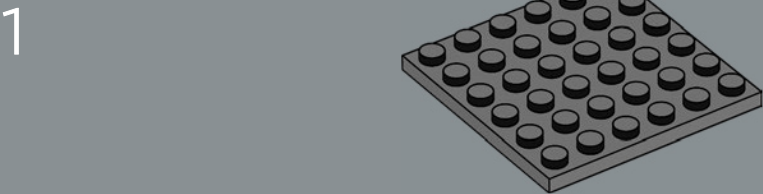
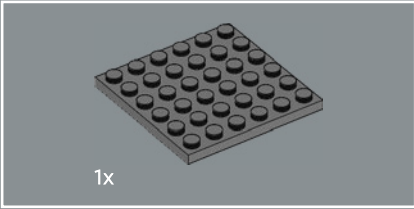
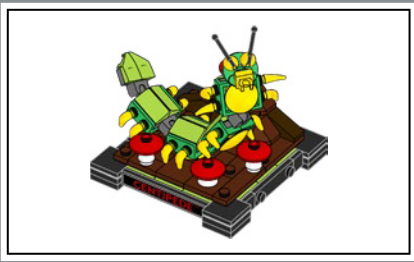



5

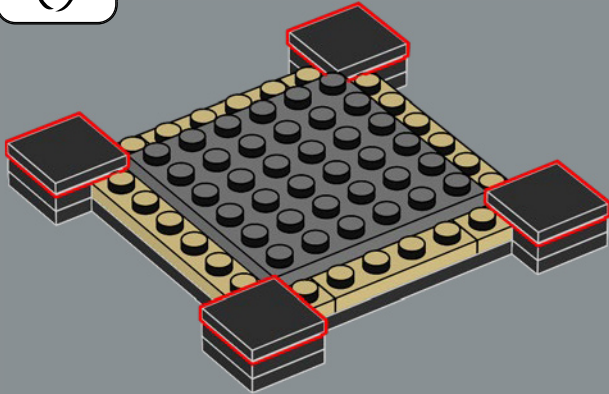

6

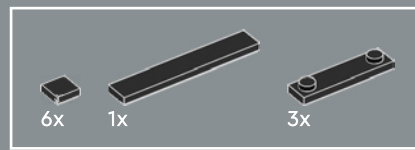
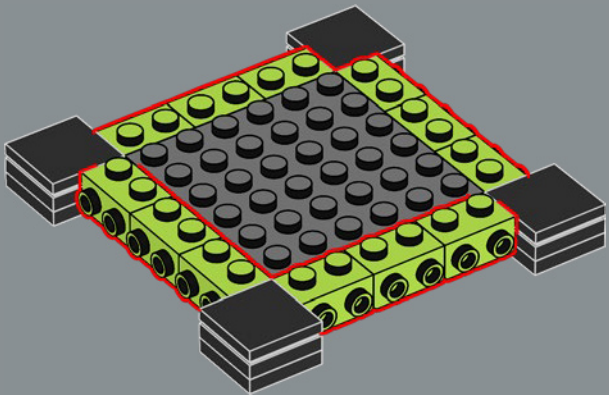

7

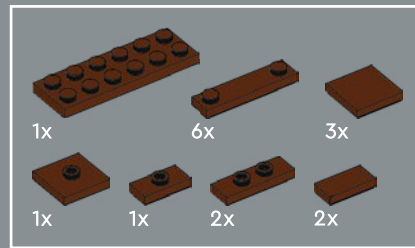
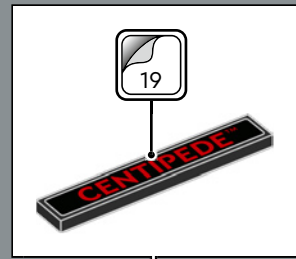
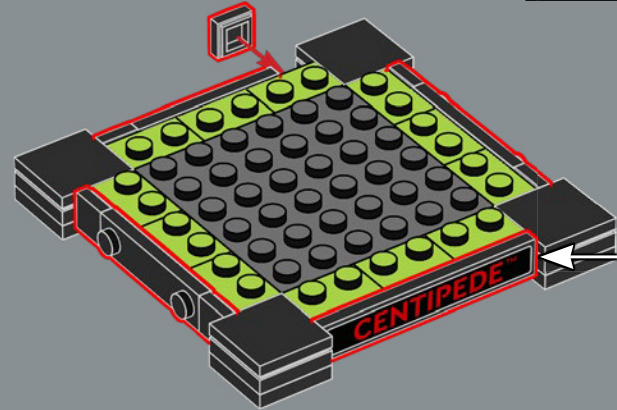

8

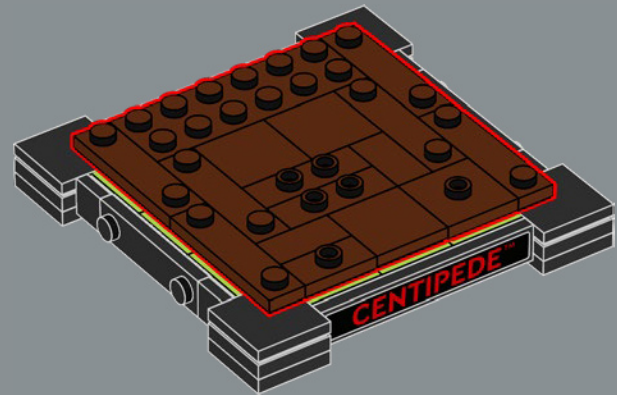

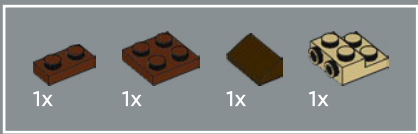

9

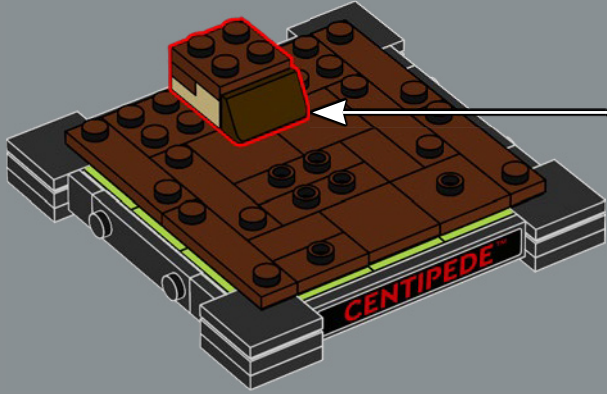
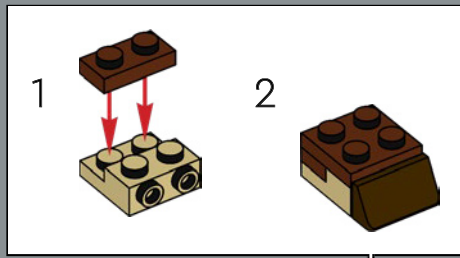

10

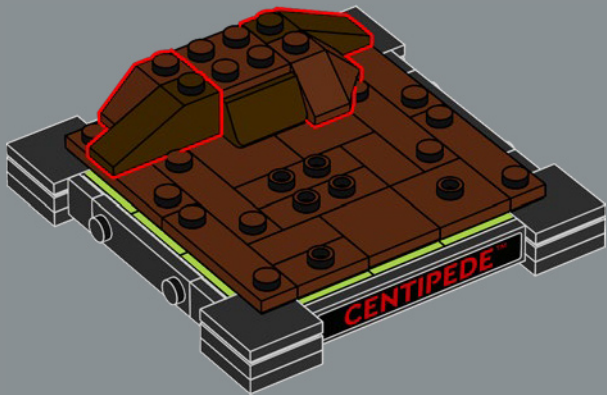

11

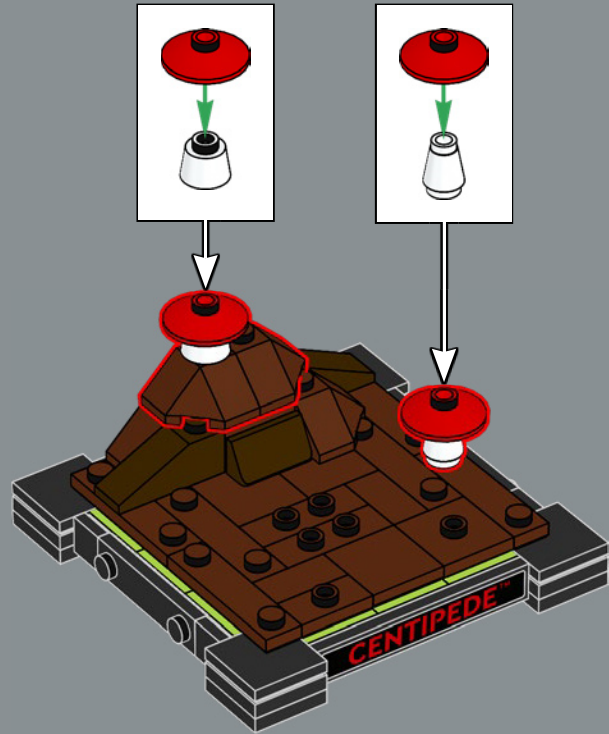

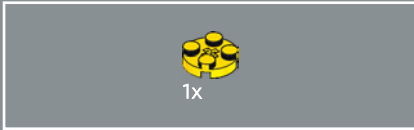
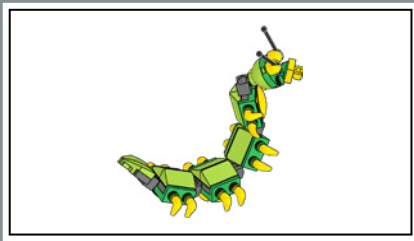

12



13

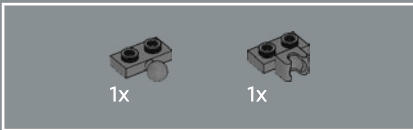

14

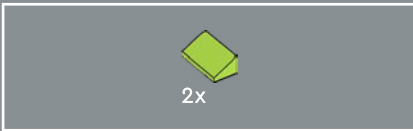
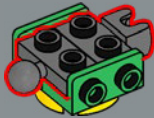

15





4x

16

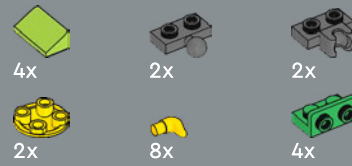
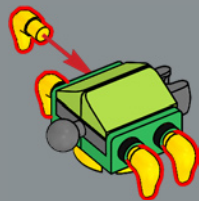

17

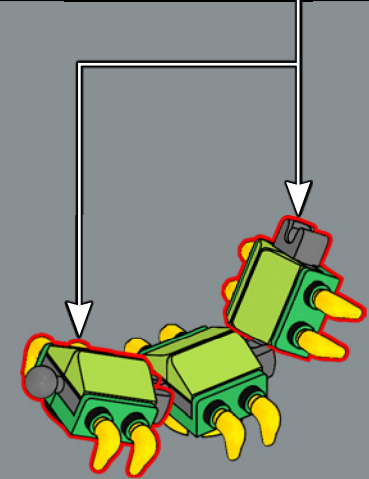
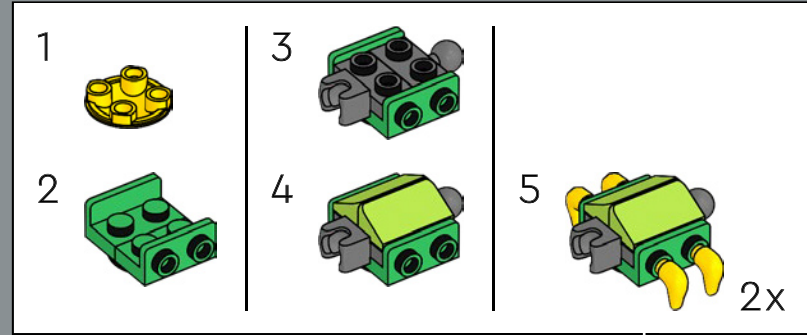

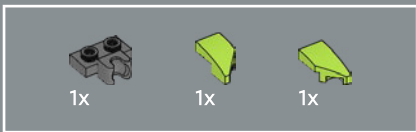

18

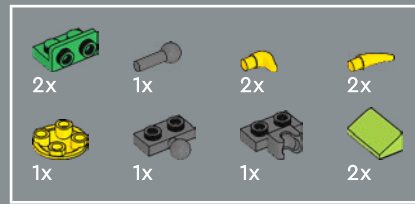
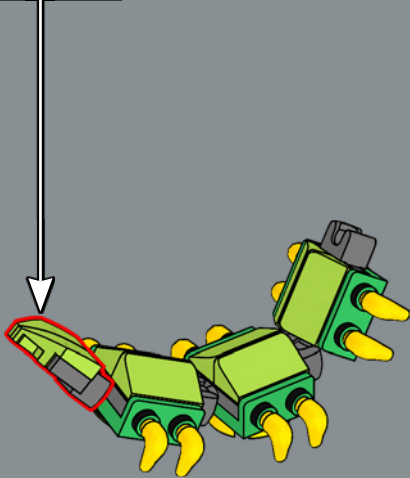
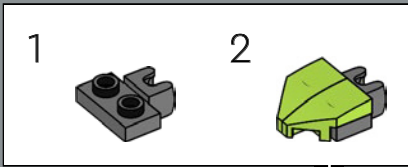

19

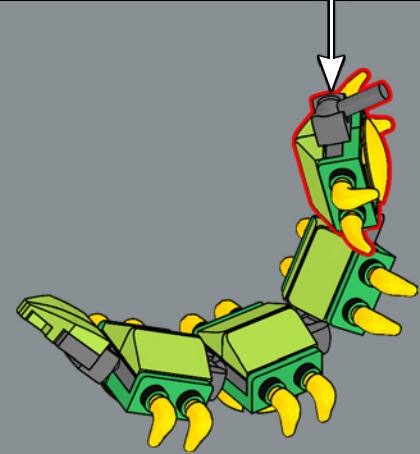
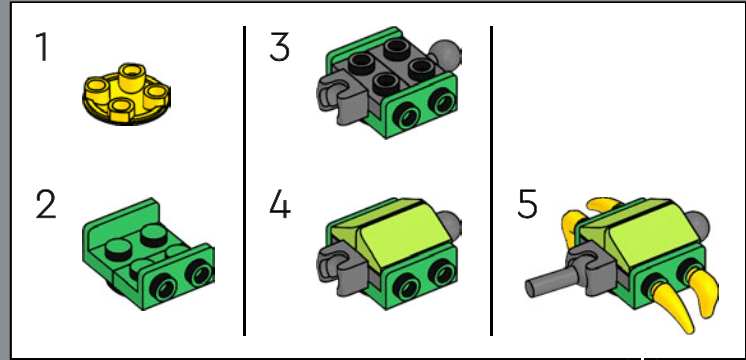

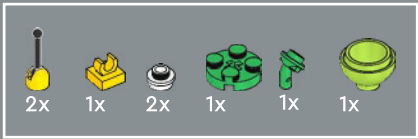

20

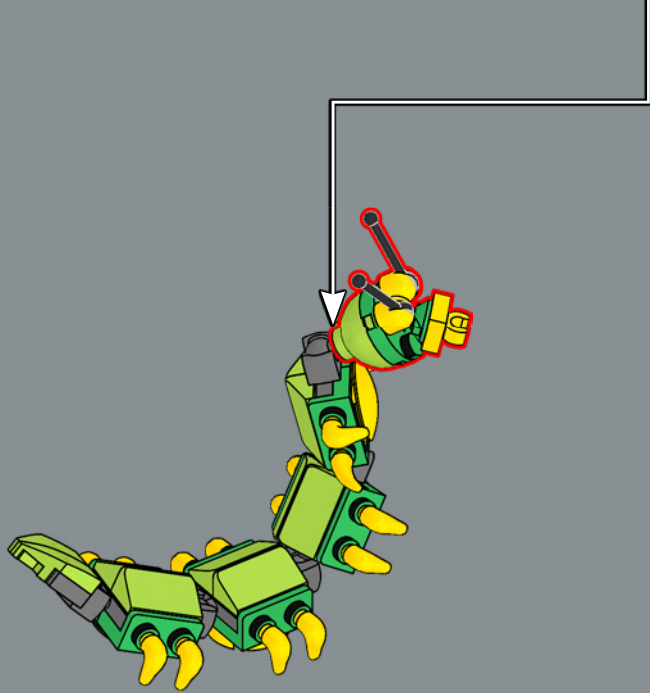
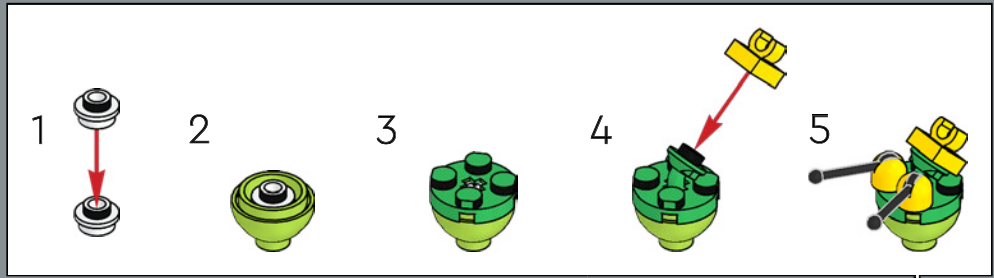

21

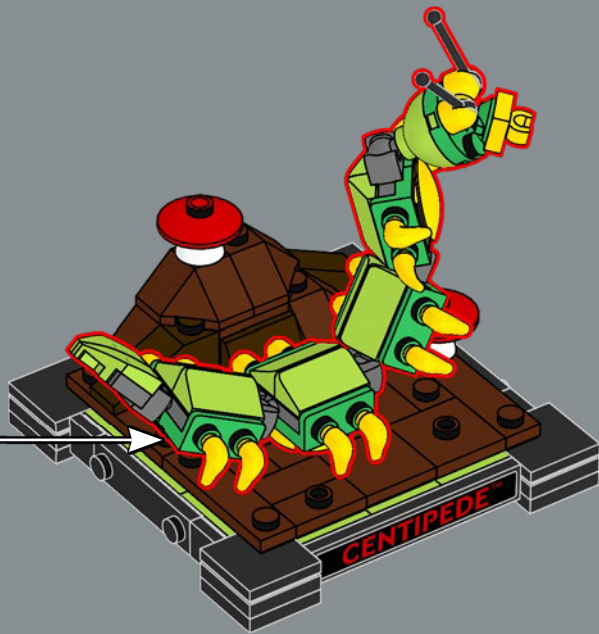

22

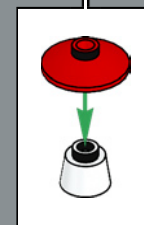
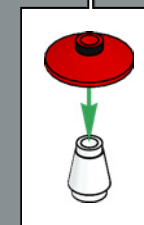
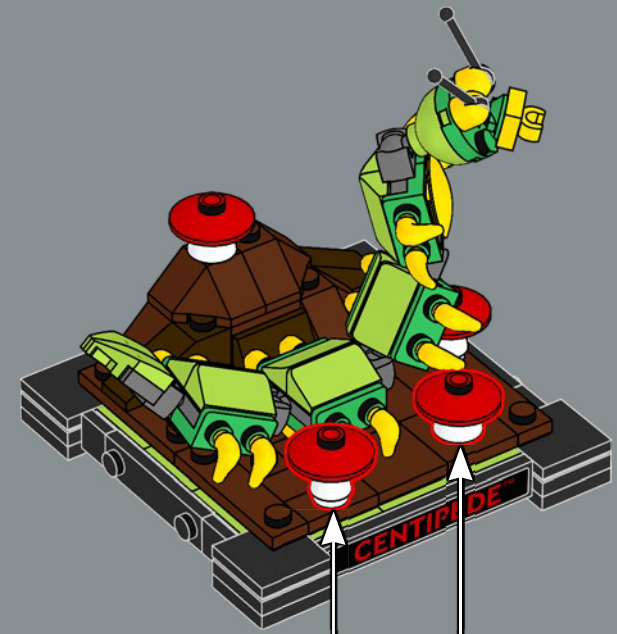
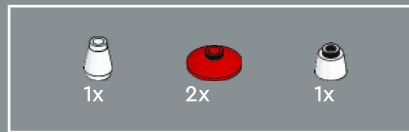



The ATARI® Video Computer System debuted on September 11, 1977, for a price of \$189.95 US (over \$800 in today's money!)

La console de jeux vidéo ATARI® a été lancée le 11 septembre 1977, au prix de 189,95 \$ US (plus de 800 \$ en dollars d'aujourd'hui!).

El ATARI® Video Computer System debutó el 11 de septiembre de 1977 a un precio de 189,95 USD (¡más de 800 USD en dinero de hoy!).

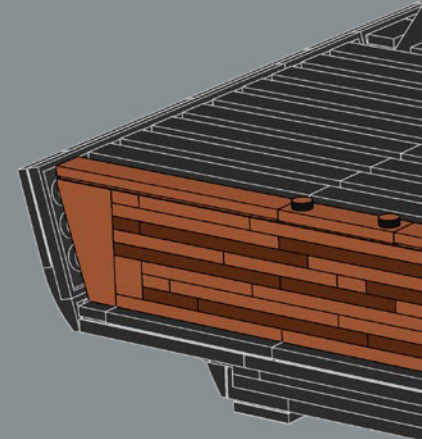
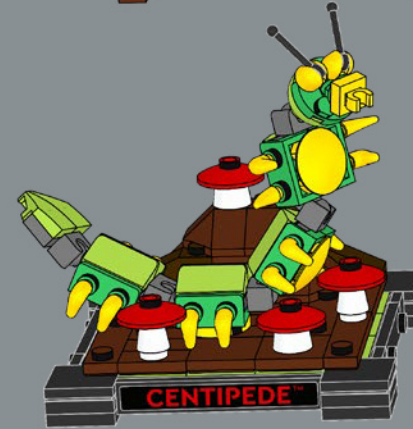
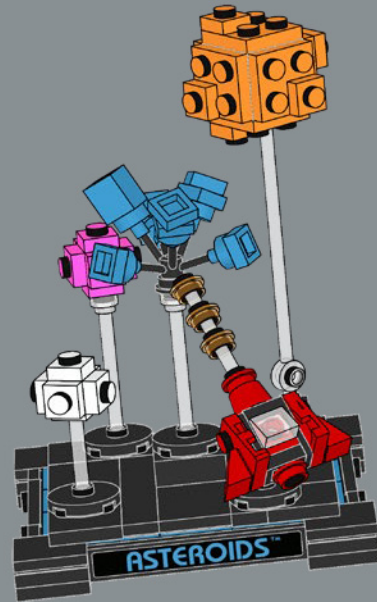
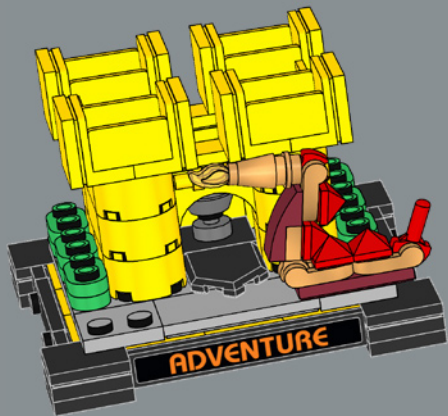

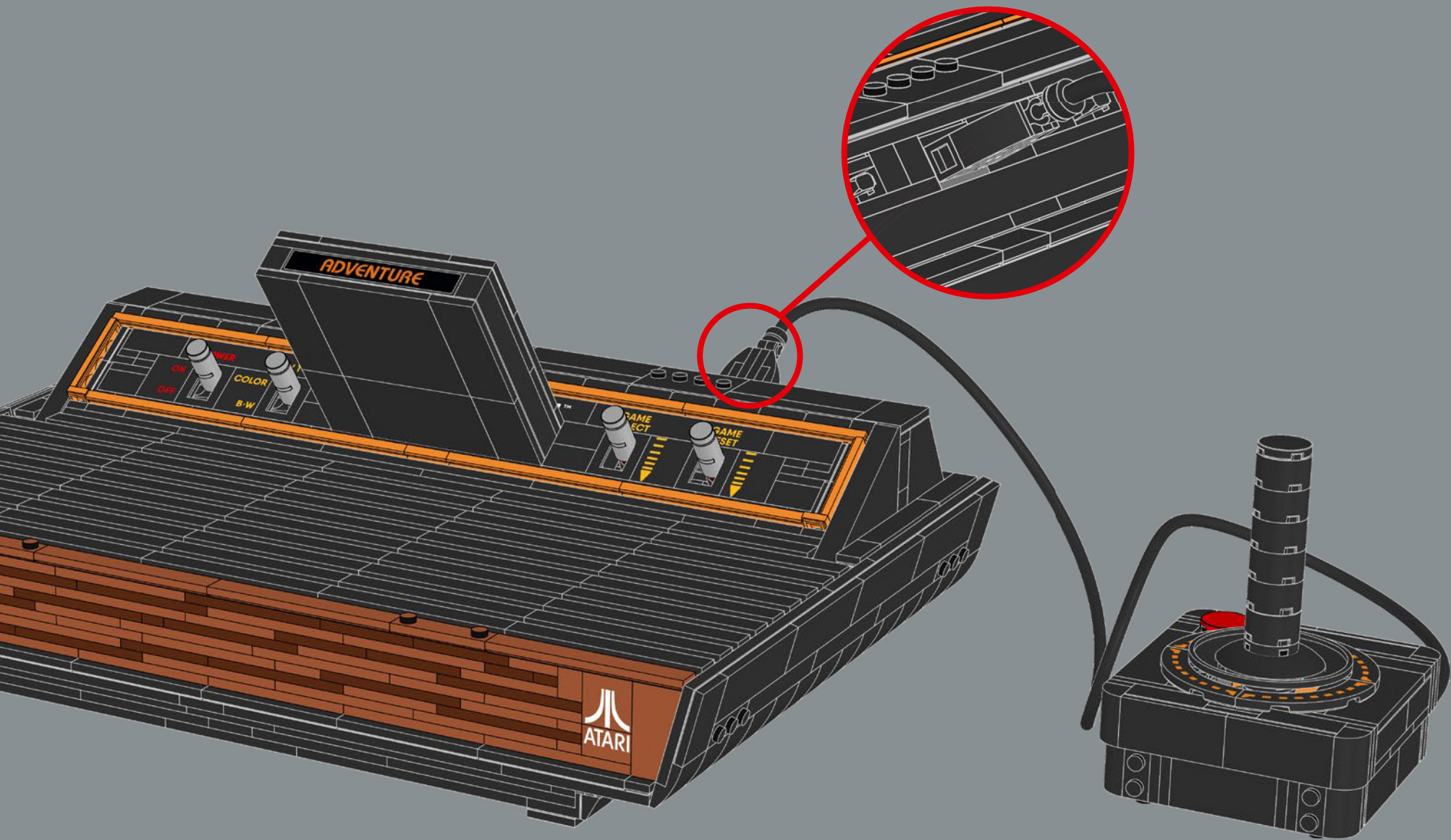



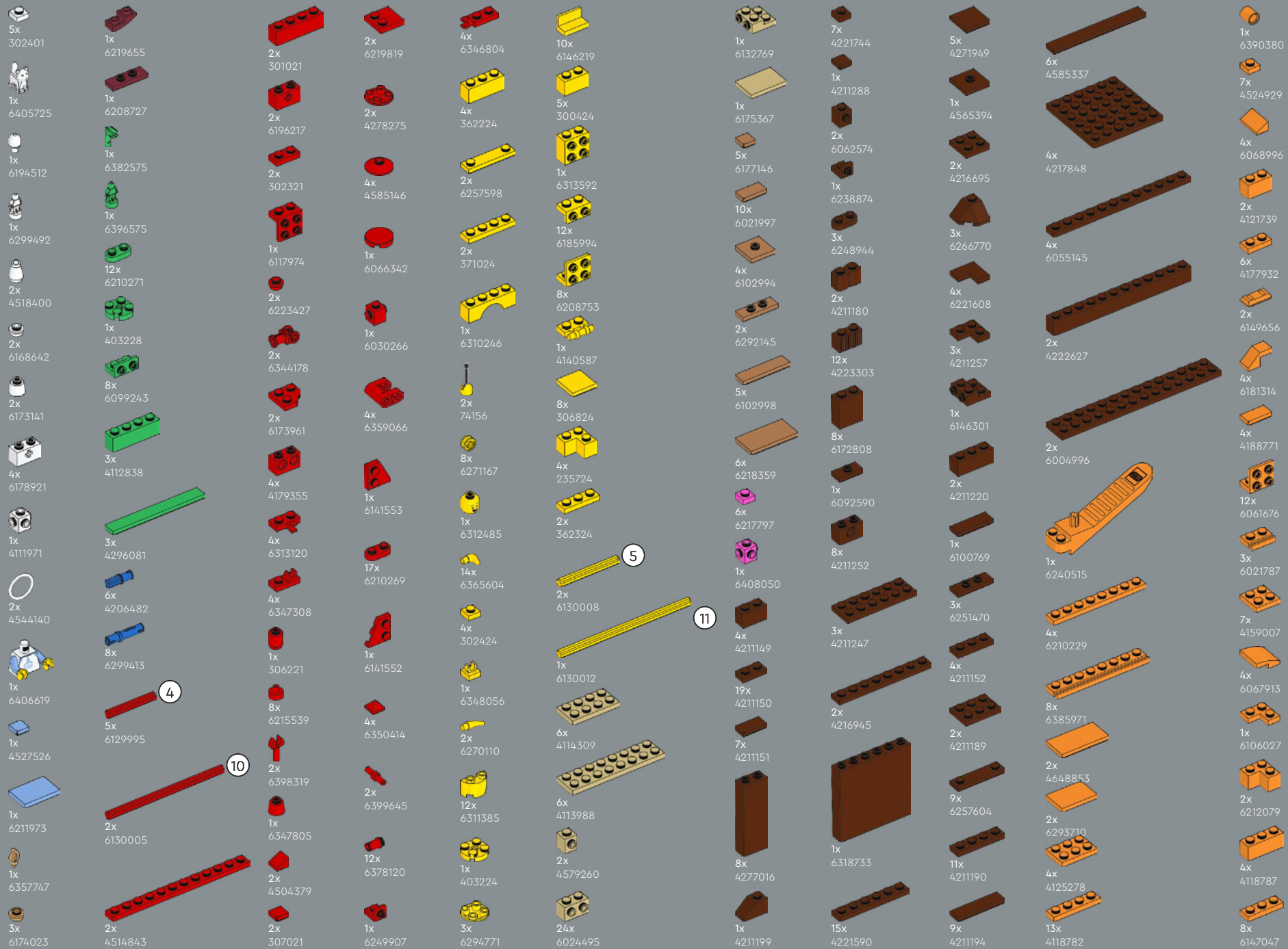

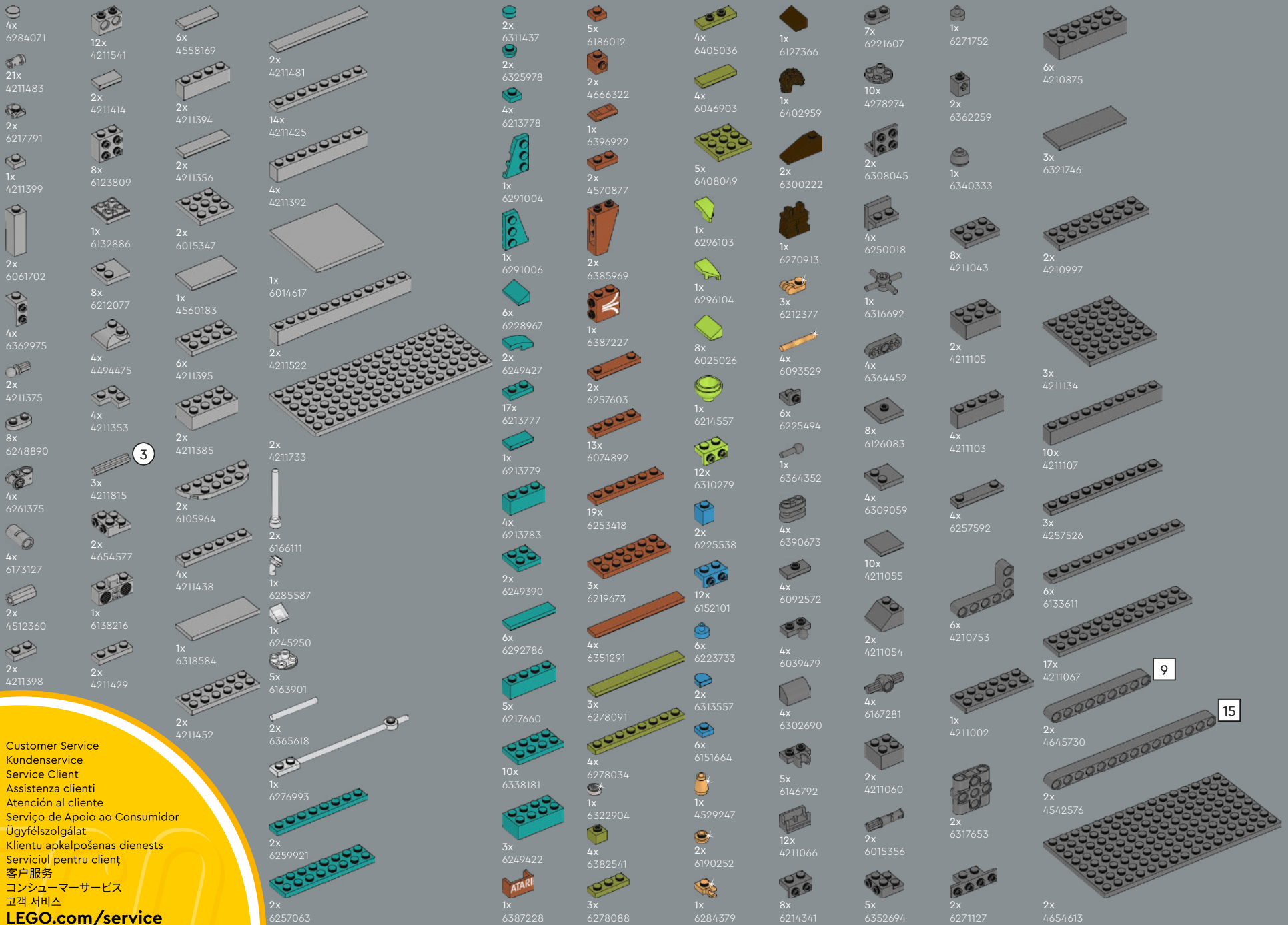

Customer Service
 Kundenservice
 Service Client
 Assistenza clienti
 Atención al cliente
 Serviço de Apoio ao Consumidor
 Ügyfélszolgálat
 Klientu apkalpošanas dienests
 Serviciul pentru client
 客户服务
 コンシューマーサービス
 고객 서비스
LEGO.com/service

3

9

15



1x
6387228



FEEDBACK AND WIN



FEEDBACK AND WIN

Your feedback will help shape the future development of this product series.

Please visit:

FEEDBACK UND GEWINNEN

Dein Feedback trägt zur Weiterentwicklung dieser Produktreihe bei.

Geh auf:

COMMENTEZ ET GAGNEZ

Vos commentaires nous aideront à concevoir les futurs produits de cette gamme.

Rendez-vous sur :

COMENTA Y GANA

Tu opinión nos ayudará a dar forma al desarrollo de esta serie de productos en el futuro.

Visita:

反馈有奖

您的反馈将有助于我们在今后改进本系列产品。

请访问：

[LEGO.com/productfeedback](https://www.lego.com/productfeedback)

By completing, you will automatically enter a drawing to win a LEGO® set.

Terms & Conditions apply.

Durch Ausfüllen nimmst du automatisch an der Verlosung eines LEGO® Preises teil.

Es gelten die Teilnahmebedingungen.

En envoyant vos commentaires, vous serez automatiquement inscrit(e) à un tirage au sort qui vous permettra de remporter un prix LEGO®.

Offre soumise à conditions.

Al contestar, participarás automáticamente en el sorteo y podrás ganar un set LEGO®.

Sujeto a Términos y Condiciones.

完成我们的反馈调查，即可自动进入抽奖环节，赢取乐高®套装。

适用《条款和条件》。

LEGO and the LEGO logo are trademarks of the/son des marques de commerce du/son marcas registradas de LEGO Group. ©2022 The LEGO Group.

©2022 Atari Interactive, Inc. Atari and the Atari logo are registered trademarks owned by Atari Interactive, Inc. Used under license.

CONSOLE DE JEUX VIDÉO
